

JM-1P Arrayable Loudspeaker



***Keep these important operating instructions.
Check www.meyersound.com for updates.***

DECLARATION OF CONFORMITY ACCORDING TO ISO/IEC GUIDE 22 AND EN 45014

Manufacturer's Name: Meyer Sound Laboratories Inc.

Manufacturer's Address: 2832 San Pablo Avenue
Berkeley, CA 94702-2204, USA

Declares that the product:

Product Names: JM-1P Arrayable Loudspeaker

Product Options: All

Conforms to the following Product Specifications:

Safety: EN 60065:2002

EMC: EN55103-1: 1997 emission¹
EN55103-2: 1997 immunity²

This device also complies with EN 55103-1 & -2. Operation is subject to the following two conditions:

- (1) this device may not cause harmful interference, and
- (2) this device must accept any interference received, including interference that may cause undesired operation.

Supplementary Information: The product herewith complies with the requirements of the Low Voltage Directive (LVD) 2006/95/EC and the EMC Directive 2004/108/EC.

Signature:



Ms. Margie Garza
Director of Quality
Meyer Sound Laboratories Inc.
Berkeley, California 94702 USA
Issued November 3, 2009

European Contact:
Your local Meyer Sound dealer or
Meyer Sound Germany, GmbH.

© 2009

Meyer Sound. All rights reserved.

JM-1P Operating Instructions, PN 05.202.005.01 A





The contents of this manual are furnished for informational purposes only, are subject to change without notice, and should not be construed as a commitment by Meyer Sound Laboratories Inc. Meyer Sound assumes no responsibility or liability for any errors or inaccuracies that may appear in this manual. Except as permitted by applicable copyright law, no part of this publication may be reproduced, stored in a retrieval system, or transmitted, in any form or by any means, electronic, mechanical, recording or otherwise, without prior written permission from Meyer Sound.

GuideALink, Intelligent AC, JM-1P, MAPP Online Pro, RMS, QuietCool, and all alpha-numeric designations for Meyer Sound products and accessories are trademarks of Meyer Sound. Compass, Galileo, Meyer Sound, the Meyer Sound wave logo, QuickFly, and SIM are registered trademarks of Meyer Sound Laboratories Inc. (Reg. U.S. Pat. & Tm. Off.). All third-party trademarks mentioned herein are the property of their respective trademark holders.

Printed in the USA.

SYMBOLS USED

These symbols indicate important safety or operating features in this booklet and on the chassis:

			
Dangerous voltages: risk of electric shock	Important operating instructions	Frame or chassis	Protective earth ground
Pour indiquer les risques résultant de tensions dangereuses	Pour indiquer important instructions	Masse, châssis	Terre de protection
Warnung vor gefährlicher elektrischer Spannung	Wichtige Betriebsanweisung oder Gebrauchsanleitung	Rahmen oder Gehäuse	Masse Schutzleiter
Para indicar voltajes peligrosos	Instrucciones importantes de funcionamiento y/o mantenimiento	Armadura o chasis	Tierra proteccionista

IMPORTANT SAFETY INSTRUCTIONS

1. Read these instructions.
2. Keep these instructions.
3. Heed all warnings.
4. Follow all instructions.
5. Do not use this loudspeaker near water.
6. Clean only with dry cloth.
7. Do not block any ventilation openings. Install in accordance with Meyer Sound's installation instructions.
8. Do not install near any heat sources such as radiators, heat registers, stoves, or other apparatus that produce heat.
9. Do not defeat the safety purpose of the grounding-type plug. A grounding type plug has two blades and a third grounding prong. The third prong is provided for your safety. If the provided plug does not fit into your outlet, consult an electrician for replacement of the obsolete outlet.
10. Protect the power cord from being walked on or pinched, particularly at plugs, convenience receptacles, and the point where they exit from the loudspeaker. The AC mains plug or appliance coupler shall remain readily accessible for operation.
11. Only use attachments/accessories specified by Meyer Sound.
12. Use only with the caster rails or rigging specified by Meyer Sound, or sold with the loudspeaker. Handles are for carrying only.

 **CAUTION:** Rigging should only be done by experienced professionals.
13. Unplug this loudspeaker during lightning storms or when unused for long periods of time.
14. Disconnect the mains plug before disconnecting the power cord from the loudspeaker.
15. Refer all servicing to qualified service personnel. Servicing is required when the loudspeaker has been damaged in any way, such as when the power-supply cord or plug has been damaged; liquid has been spilled or objects have fallen into the loudspeaker; rain or moisture has entered the loudspeaker; the loudspeaker has been dropped; or when for undetermined reasons the loudspeaker does not operate normally.

 **CAUTION:** To reduce the risk of electric shock, do not expose this loudspeaker to rain or moisture. Do not install the loudspeaker in wet or humid locations without using weather protection equipment from Meyer Sound.

SAFETY SUMMARY

English

- To reduce the risk of electric shock, disconnect the loudspeaker from the AC mains before installing audio cable. Reconnect the power cord only after making all signal connections.
- Connect the loudspeaker to a two-pole, three-wire grounding mains receptacle. The receptacle must be connected to a fuse or circuit breaker. Connection to any other type of receptacle poses a shock hazard and may violate local electrical codes.
- Do not install the loudspeaker in wet or humid locations without using weather protection equipment from Meyer Sound.
- Do not allow water or any foreign object to get inside the loudspeaker. Do not put objects containing liquid on or near the unit.
- To reduce the risk of overheating the loudspeaker, avoid exposing it to direct sunlight. Do not install the unit near heat-emitting appliances, such as a room heater or stove.
- This loudspeaker contains potentially hazardous voltages. Do not attempt to disassemble the unit. The unit contains no user-serviceable parts. Repairs should be performed only by factory-trained service personnel.

Français

- Pour réduire le risque d'électrocution, débrancher la prise principale de l'haut-parleur, avant d'installer le câble d'interface allant à l'audio. Ne rebrancher le bloc d'alimentation qu'après avoir effectué toutes les connections.
- Branchez l'haut-parleur dans une prise de courant à 3 dérivation (deux pôles et la terre). Cette prise doit être munie d'une protection adéquate (fusible ou coupe-circuit). Le branchement dans tout autre genre de prise pourrait entraîner un risque d'électrocution et peut constituer une infraction à la réglementation locale concernant les installations électriques.

- Ne pas installer l'haut-parleur dans un endroit où il y a de l'eau ou une humidité excessive.
- Ne pas laisser de l'eau ou tout objet pénétrer dans l'haut-parleur. Ne pas placer de récipients contenant un liquide sur cet appareil, ni à proximité de celui-ci.
- Pour éviter une surchauffe de l'haut-parleur, conserver-la à l'abri du soleil. Ne pas installer à proximité d'appareils dégageant de la chaleur tels que radiateurs ou appareils de chauffage.
- Ce haut-parleur contient des circuits haute tension présentant un danger. Ne jamais essayer de le démonter. Il n'y a aucun composant qui puisse être réparé par l'utilisateur. Toutes les réparations doivent être effectuées par du personnel qualifié et agréé par le constructeur.

Deutsch

- Um die Gefahr eines elektrischen Schlages auf ein Minimum zu reduzieren, den Lautsprecher vom Stromnetz trennen, bevor ggf. ein Audio-Schnittstellensignalkabel angeschlossen wird. Das Netzkabel erst nach Herstellung aller Signalverbindungen wieder einstecken.
- Der Lautsprecher an eine geerdete zweipolige Dreiphasen-Netzsteckdose anschließen. Die Steckdose muß mit einem geeigneten Abzweigschutz (Sicherung oder Leistungsschalter) verbunden sein. Der Anschluß der unterbrechungsfreien Stromversorgung an einen anderen Steckdosentyp kann zu Stromschlägen führen und gegen die örtlichen Vorschriften verstoßen.
- Der Lautsprecher nicht an einem Ort aufstellen, an dem sie mit Wasser oder übermäßig hoher Luftfeuchtigkeit in Berührung kommen könnte.
- Darauf achten, daß weder Wasser noch Fremdkörper in das Innere den Lautsprecher eindringen. Keine Objekte, die Flüssigkeit enthalten, auf oder neben die unterbrechungsfreie Stromversorgung stellen.

- Um ein Überhitzen dem Lautsprecher zu verhindern, das Gerät vor direkter Sonneneinstrahlung fernhalten und nicht in der Nähe von wärmeabstrahlenden
- Haushaltsgeräten (z.B. Heizgerät oder Herd) aufstellen.
- Im Inneren diesem Lautsprecher herrschen potentiell gefährliche Spannungen. Nicht versuchen, das Gerät zu öffnen. Es enthält keine vom Benutzer reparierbaren Teile. Reparaturen dürfen nur von ausgebildetem Kundendienstpersonal durchgeführt werden.

Español

- Para reducir el riesgo de descarga eléctrica, desconecte de la red de voltaje el altoparlante antes de instalar el cable de señal de audio. Vuelva a conectar la alimentación de voltaje una vez efectuadas todas las interconexiones de señalización de audio.
- Conecte el altoparlante a un tomacorriente bipolar y trifilar con neutro de puesta a tierra. El tomacorriente debe estar conectado a la protección de derivación apropiada (ya sea un fusible o un disyuntor). La conexión a cualquier otro tipo de tomacorriente puede constituir peligro de descarga eléctrica y violar los códigos eléctricos locales.
- No instale el altoparlante en lugares donde haya agua o humedad excesiva.
- No deje que en el altoparlante entre agua ni ningún objeto extraño. No ponga objetos con líquidos encima de la unidad ni cerca de ella.
- Para reducir el riesgo de sobrecalentamiento, no exponga la unidad a los rayos directos del sol ni la instale cerca de artefactos que emiten calor, como estufas o cocinas.
- Este altoparlante contiene niveles de voltaje peligrosos en potencia. No intente desarmar la unidad, pues no contiene piezas que puedan ser reparadas por el usuario. Las reparaciones deben efectuarse únicamente por parte del personal de mantenimiento capacitado en la fábrica.

CONTENTS

Chapter 1: Introduction	7
How to Use This Manual	7
Introducing the JM-1P Loudspeaker	7
Chapter 2: Power Requirements	9
AC Power Distribution	9
The AC Connectors	9
Power Connector Wiring	10
JM-1P Voltage Requirements	10
JM-1P Current Requirements	11
Electrical Safety Issues	12
Chapter 3: Amplification and Audio	13
VEAM Cabling	13
The Looping Audio Input Module	13
Amplifier Cooling System	15
Chapter 4: Adding Subwoofers to a JM-1P Loudspeaker System	17
The Galileo® Loudspeaker Management System	17
Using Digital Signal Processors	18
Chapter 5: QuickFly® Rigging	19
The JM-1P GuideALinks™	19
The MPA-JM1 Pickup Plate	21
The MTG-JM1 Vertical Grid	24
The MDB-JM1 Dolly Board	25
Chapter 6: The RMS™ Remote Monitoring System	27
The RMS Software	27
The RMS Module	28
Resetting the RMS Module	29
Chapter 7: System Design and Integration Tools	31
MAPP Online Pro™	31
The SIM® 3 Measurement System	32
Appendix A: Optional VEAM Multipin Connector	33
Appendix B: Optional Rain Hoods	35
Appendix C: JM-1P Specifications	39

CHAPTER 1: INTRODUCTION

HOW TO USE THIS MANUAL

Make sure to read these operating instructions in their entirety before configuring a loudspeaker system with JM-1P loudspeakers. In particular, pay close attention to material related to safety issues.

As you read these operating instructions, you will encounter the following icons for notes, tips, and cautions:



NOTE: A note identifies an important or useful piece of information relating to the topic under discussion.



TIP: A tip offers a helpful tip relevant to the topic at hand.



CAUTION: A caution gives notice that an action may have serious consequences and could cause harm to equipment or personnel, or could cause delays or other problems.

Information and specifications are subject to change. Updates and supplementary information are available on the Meyer Sound website:

<http://www.meyersound.com>

Meyer Sound Technical Support is available at:

- **Tel:** +1 510 486.1166
- **Fax:** +1 510 486.8356
- **Email:** techsupport@meyersound.com

INTRODUCING THE JM-1P LOUDSPEAKER

The JM-1P self-powered loudspeaker is a high-Q, arrayable loudspeaker suited for a wide range of applications. Utilizing Meyer Sound's patented REM™ technology and trapezoidal cabinet design, the JM-1P can be deployed in tightly-packed array clusters to deliver coverage that is proportional to the number of units in the array. While JM-1P point source arrays are optimized for horizontal installations, they can also be used vertically when necessary. With its scalable coverage and versatile QuickFly® rigging options, the JM-1P loudspeaker can be used for touring, rental, and fixed installations.



JM-1P Arrayable Loudspeaker

Boasting a wide operating frequency range of 53 Hz to 18 kHz, the JM-1P delivers a remarkably smooth sound with ample low-frequency headroom. Designed and manufactured at Meyer Sound headquarters in Berkeley, California, the JM-1P's drivers include one low-frequency 15-inch long excursion cone driver, and one high-frequency 4-inch compression driver with an REM manifold coupled to an extremely accurate horn. The JM-1P is distinguished by its constant-Q horn that provides a 20-degree horizontal by 60-degree vertical coverage. The unit's consistent polar response and trapezoidal enclosure allow for tightly packed arrays with minimal overlap in high frequencies.

The JM-1P's sophisticated onboard amplification and processing produces consistent and predictable results in any system design. A proprietary two-channel, class AB/H power amplifier with complementary MOSFET output stages yields a total power output of 1275 W (2550 W peak). Built-in signal processing includes an electronic crossover, driver protection, and correction filters for achieving flat phase and frequency responses. Each amplifier channel has peak and rms limiters that prevent driver overexcursion and regulate voice coil temperatures. Limiting activity is easily monitored with the rear panel limit LEDs. The optional RMS™ remote monitoring system provides comprehensive monitoring of system parameters on a Windows®-based computer.

The JM-1P's end plates include captive GuideALinks™ and quick-release pins that allow the unit to be easily linked with other JM-1Ps in arrays. The optional MPA-JM1 pickup plate suspends JM-1P horizontal arrays of up to four units with uptilt or downtilt from a single hanging point; two pickup plates can suspend arrays of up to six units from a single hanging point or motor using the MTGSB-4B spreader bar.



JM-1P Horizontal Array with MPA-JM1 Pickup Plates and MTGSB-4B Spreader Bar

The optional MTG-JM1 grid suspends vertical arrays of up to six JM-1Ps.



MTG-JM1 Vertical Grid with Two JM-1Ps

Constructed of premium birch plywood, the durable JM-1P enclosure is coated with a black-textured, hard-shell finish. A hex-stamped, steel grille with acoustical black mesh protects the unit's drivers. Other options include weather protection and custom color finishes for fixed installations and applications with specific cosmetic requirements. The optional MDB-JM1 dolly board transports the JM-1P on caster wheels; multiple dolly boards can be interlocked to transport up to three linked JM-1Ps.

CHAPTER 2: POWER REQUIREMENTS

The JM-1P loudspeaker combines advanced loudspeaker technology with equally advanced power capabilities. Understanding power distribution, voltage and current requirements, as well as electrical safety issues, is critical to the safe operation of the JM-1P.

AC POWER DISTRIBUTION

All components in an audio system (self-powered loudspeakers, processors, etc.) must be properly connected to an AC power distribution system, ensuring that AC line polarity is preserved, and that all grounding points are connected to a single node or common point using the same cable gauge as the neutral and line cables.

 **NOTE:** Improper grounding connections between loudspeakers and the rest of the audio system may produce noise or hum, or cause serious damage to the input and output stages of the system's electronic components.

 **CAUTION:** Before applying AC power to any Meyer Sound self-powered loudspeaker, make sure that the voltage potential difference between neutral and earth ground is less than 5 V AC.

Figure 1 illustrates a basic three-phase AC distribution system with the loudspeaker load distributed across the three phases. All loudspeakers are connected to common neutral and earth-ground points.

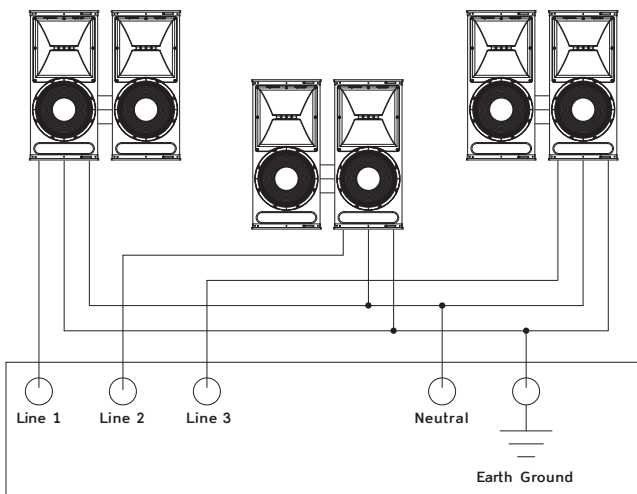
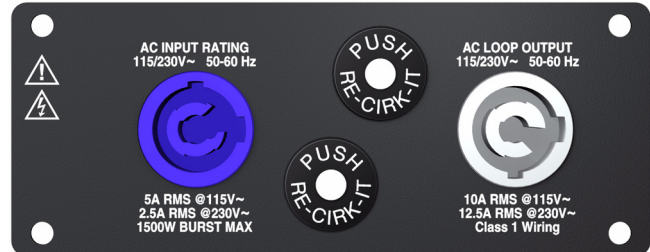

Figure 1: AC Power Distribution System

THE AC CONNECTORS

The user panel on the back of the JM-1P includes the following PowerCon® AC connectors:



JM-1P AC Input (left) and AC Loop Output (right) Connectors

The AC Input Connector (Blue)

The blue AC Input connector supplies power to the JM-1P. The connector is rated at 20 amps and uses a PowerCon AC mains locking connector that prevents accidental disconnections. A 10-foot AC power cable, rated at 15 amps, is included with each loudspeaker. If you replace the included AC power cable, make sure to use a cable with the appropriate power plug (on the other end) for the area in which you will operate the unit.

The AC Input connector also supplies power to any additional loudspeakers connected to the loudspeaker's gray Loop Output connector. Each JM-1P loudspeaker requires approximately 5 A rms (maximum long-term continuous current) at 115 V AC for proper operation.

 **CAUTION:** When using the included AC power cable, do not loop more than two additional JM-1P loudspeakers from the AC Loop Output connector at 115 V (three total for the circuit), and not more than five at 230 V (six total for the circuit).

The AC Loop Output Connector (Gray)

The gray AC Loop Output connector allows multiple JM-1P loudspeakers to be looped and powered from a single power source. Connect the AC Loop Output of the first loudspeaker to the AC Input of the second, and so forth. The AC Loop Output uses a PowerCon3 AC mains locking connector that prevents accidental disconnections.

The maximum number of loudspeakers that can be looped from the Loop Output connector is determined by the voltage of the power source, the circuit breaker rating, and the rating of the AC power cable connected to the first JM-1P loudspeaker.

Number of JM-1Ps that Can Be Looped with AC Power

Circuit Breaker/ Connector Rating	115 V AC	230 V AC	100 V AC
15 amps	2 looped (3 total)	5 looped (6 total)	1 looped (2 total)
20 amps	3 looped (4 total)	7 looped (8 total)	2 looped (3 total)

Each JM-1P loudspeaker ships with one AC looping connector for making AC looping cables. Assembled AC looping cables are available from Meyer Sound (15-inch UL AC looping cable, PN 28.115.032.01; 0.35 m CE AC looping cable, PN 28.115.032.02).

CAUTION: Do not exceed the current capability of the 20-amp Input connector for the JM-1P loudspeakers. When looping loudspeakers, consider the total current draw for all loudspeakers on the circuit, *including* the first loudspeaker.

AC Connections with VEAM Cabling

The JM-1P can be ordered from the factory with a VEAM all-in-one connector. VEAM connectors consolidate AC power, audio, and RMS into a single cable, facilitating easy connections and quick setups. For more information, see Appendix A, “Optional VEAM Multipin Connector.”

POWER CONNECTOR WIRING

The JM-1P requires a grounded outlet. To operate safely and effectively, it is extremely important that the entire system be properly grounded.

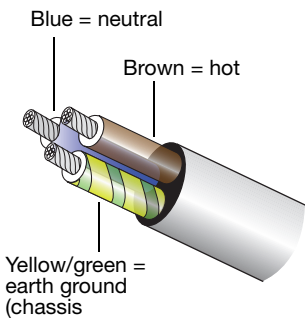

AC Cable Wiring Scheme

When wiring international or special-purpose power connectors:

- Connect the blue wire to the black terminal, or the terminal marked with an N.
- Connect the brown wire to the red terminal, or the terminal marked with an L.
- Connect the yellow and green wire to the green (or green and yellow) terminal, or the terminal marked with an E.

CAUTION: When creating AC power cables and distribution systems, it is important to preserve AC line polarity and connect the earth ground on both ends of the cable. The JM-1P requires a grounded connection. Always use a grounded outlet and plug. It is extremely important that the system be properly grounded in order to operate safely and properly. Do not ground-lift the AC cable.

JM-1P VOLTAGE REQUIREMENTS

The JM-1P operates safely and continuously when the AC voltage stays within 95–125 V AC and 208–235 V AC at 50 or 60 Hz. The JM-1P allows any combination of voltage to GND (neutral-line-ground or line-line-ground).

If the voltage drops below 85 V (brownout), the JM-1P uses stored power to continue operating temporarily; the loudspeaker will shut down if the voltage does not rise above the low boundary before the stored power is used.

If the voltage rises above 235 V, the power supply could become damaged.

CAUTION: The power source for the JM-1P should always operate within the required voltage range, at least a few volts from the upper and lower ranges. This will ensure that AC voltage variations from the service entry — or peak voltage drops due to cable runs — will not cause the loudspeaker’s amplifiers to cycle on and off or cause damage to the power supply.

Powering Up the JM-1P

When AC power is applied to the JM-1P, its Intelligent AC™ power supply automatically selects the correct operating voltage, allowing it to be used internationally without manually setting voltage switches. In addition, Intelligent AC also suppresses high-voltage transients up to several kilovolts, filters common mode and differential mode radio frequencies (EMI), and sustains operation temporarily during low-voltage periods.

When powering up the JM-1P, the following startup events take place over several seconds.

1. Audio output is muted.
2. Voltage is detected and the power supply mode is automatically adjusted as necessary.
3. The power supply ramps up.
4. The green On/Temp LED on the user panel lights up, indicating the loudspeaker is ready to output audio.

 **NOTE:** The fan remains off at turn-on. It is controlled by audio level and operates only at high audio levels.

 **CAUTION:** If the On/Temp LED does not light up, or the loudspeaker does not output audio after ten seconds, remove AC power immediately and verify that the voltage is within the required range. If the problem persists, contact Meyer Sound Technical Support.

 **CAUTION:** If either of the loudspeaker's circuit breakers trip (the white center buttons disengage), make sure to disconnect the AC power cable before resetting the breakers. If necessary, contact Meyer Sound for repair information.

JM-1P CURRENT REQUIREMENTS

The current draw for the JM-1P is dynamic and fluctuates as operating levels change. Since different cables and circuit breakers heat up at varying rates, it is important to understand the following types of current ratings and how they affect circuit breaker and cable specifications.

- **Idle Current** — The maximum rms current during idle periods.
- **Maximum Long-Term Continuous Current** — The maximum rms current during a period of at least 10 seconds. The Maximum Long-Term Continuous Current is used to calculate temperature increases for cables, to ensure that cable sizes and gauges conform to electrical code standards. The current rating is also used as a rating for slow-reacting thermal breakers. In addition, the Maximum Long-Term Continuous Current can be used to calculate the AC looping capability of the JM-1P.

- **Burst Current** — The maximum rms current during a period of around one second. The Burst Current is used as a rating for magnetic breakers. It is also used for calculating the peak voltage drop in long AC cable runs according to the following formula:

$$V_{pk} (\text{drop}) = I_{pk} \times R (\text{cable total})$$

- **Ultimate Short-Term Peak Current** — A rating for fast-reacting magnetic breakers.
- **Inrush Current** — The spike of initial current encountered when powering on.

You can use the following table as a guide for selecting cable gauges and circuit breaker ratings for the system's operating voltage.

JM-1P Current Draw

Current Draw	115 V AC	230 V AC	100 V AC
Idle Current	0.50 A rms	0.28 A rms	0.56 A rms
Maximum Long-Term Continuous Current	4.55 A rms	2.50 A rms	5.25 A rms
Burst Current	8.0 A rms	4.1 A rms	9.2 A rms
Ultimate Short-Term Peak Current	20.8 A peak	13.0 A peak	21.6 A peak
Inrush Current	7.1 A peak	8.4 A peak	7.1 A peak

The minimum electrical service amperage required by a JM-1P loudspeaker system is the sum of the Maximum Long-Term Continuous Current for each loudspeaker. An additional 30 percent above the minimum amperage is recommended to prevent peak voltage drops at the service entry.

 **NOTE:** For best performance, the AC cable voltage drop should not exceed 10 V, or 10 percent at 115 V and 5 percent at 230 V. Make sure that even with AC voltage drops that the AC voltage always remains within the operating windows.

ELECTRICAL SAFETY ISSUES

Pay close attention to these important electrical and safety issues.

- The JM-1P requires a grounded outlet. Always use a grounded outlet and plug.

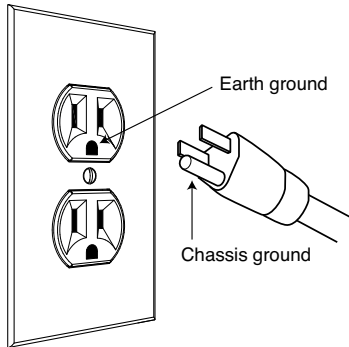

- Do not use a ground-lifting adapter or cut the AC cable ground pin.

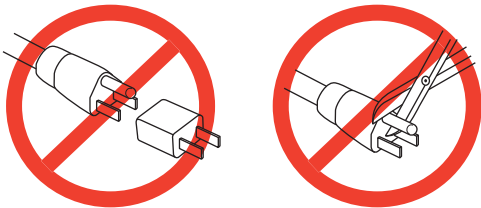

- Do not exceed the current capability of the 20-amp AC Input connector for the loudspeaker. When looping loudspeakers, consider the total current draw for all loudspeakers on the circuit, including the first loudspeaker.
- Make sure the AC power cable for the loudspeaker has the appropriate power plug (on the other end) for the area in which you will operate the loudspeaker. In addition, the AC power cable must be rated for the total current draw of all loudspeakers looped from the power source.
- Do not operate the unit if the power cables are frayed or broken.
- Keep all liquids away from the JM-1P to avoid hazards from electrical shock.

CHAPTER 3: AMPLIFICATION AND AUDIO

The JM-1P low- and high-frequency drivers are powered by a proprietary two-channel Meyer Sound amplifier with MOSFET output stages. The audio signal is processed with an electronic crossover, correction filters for phase and frequency response, and driver protection circuitry. Each channel has peak and rms limiters that prevent driver over-excitation and regulate the temperature of the voice coil.

The user panel on the back of the JM-1P has two slots for modules. The top slot contains an audio input module (described in this chapter). The bottom slot is reserved for the optional RMS module, used for connecting to the RMS remote monitoring system (see Chapter 6, “The RMS Remote Monitoring System”).

VEAM CABLING

The JM-1P can be ordered from the factory with a VEAM all-in-one connector. VEAM connectors consolidate AC power, audio, and RMS into a single cable, facilitating easy connections and quick setups. For more information, see Appendix A, “Optional VEAM Multipin Connector.”

THE LOOPING AUDIO INPUT MODULE

The Looping Audio Input module includes input and looping connectors, and LEDs for monitoring temperature and limiting.

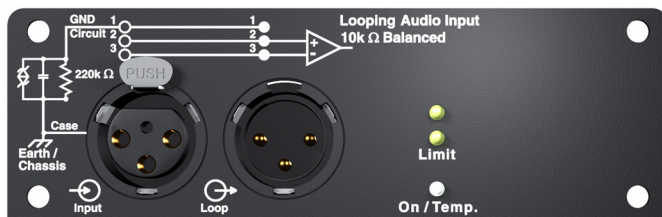

Looping Audio Input Module

Input Connector

The female XLR Input connector accepts a balanced audio signal with an input impedance of 10 kOhm. The connector uses the following wiring:

- **Pin 1** — 220 kOhm to chassis and earth ground (ESD clamped)
- **Pin 2** — Signal (+)
- **Pin 3** — Signal (-)
- **Case** — Earth (AC) ground and chassis

Pins 2 and 3 carry the input as a differential signal. Pin 1 is connected to earth through a 220 kOhm, 1000 pF, 15 V clamped network. This circuitry provides virtual ground lift for audio frequencies while allowing unwanted signals to bleed to ground. Make sure to use standard, balanced XLR audio cables with all three pins connected on both ends. Telescopic grounding is not recommended, and shorting an input connector pin to the case may cause a ground loop, resulting in hum.

 **TIP:** If unwanted noise or hiss is produced by the loudspeaker, disconnect its input cable. If the noise stops, there is most likely nothing wrong with the loudspeaker. To locate the source of the noise, check the audio cable, source audio, and AC power.

Loop Connector

The male XLR Loop connector allows multiple JM-1P loudspeakers to be looped from a single audio source. Connect the Loop output of the first loudspeaker to the Input of the second, and so forth. The Loop connector is wired in parallel to the Input connector and transmits the unbuffered source signal even when the loudspeaker is powered off.

To avoid distortion when looping multiple JM-1P loudspeakers, make sure the source device can drive the total load impedance of the looped loudspeakers. In addition, the source device must be capable of delivering 20 dBV (10 V rms into 600 ohms) to yield the maximum peak SPL over the operating bandwidth of the loudspeaker.

To calculate the load impedance for the looped loudspeakers, divide 10 kOhms (the input impedance for a single JM-1P) by the number of looped loudspeakers. For example, the load impedance for 10 JM-1P loudspeakers is 1000 ohms (10 kOhms / 10). To drive this number of looped loudspeakers, the source device should have an output impedance of 100 ohms or less. This same rule applies when looping JM-1P loudspeakers with other self-powered Meyer Sound loudspeakers and subwoofers.

 **NOTE:** Most source devices are capable of driving loads no smaller than 10 times their output impedance.

 **NOTE:** Make sure that all cabling for looped loudspeakers is wired correctly (Pin 1 to Pin 1, Pin 2 to Pin 2, and so forth) to prevent the polarity from being reversed. If one or more loudspeakers in a system have reversed polarity, frequency response and coverage can be significantly degraded.

Limit LEDs

The low- and high-frequency drivers for the JM-1P are powered by separate amplifier channels, each with their own limiter. Limiting activity is indicated with the two yellow Limit LEDs. The top LED indicates limiting for the high-frequency channel and the bottom LED indicates limiting for the low-frequency channel. When engaged, a channel's limiter not only protects the driver, but also prevents signal peaks from causing excessive distortion in the amplifier's channel, thereby preserving headroom and maintaining smooth frequency responses at high levels. When a channel's level returns to normal, below the limiter's threshold, limiting ceases.

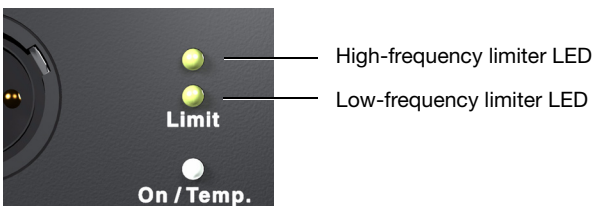

Limit LEDs

The JM-1P performs within its acoustical specifications at normal temperatures when the Limit LEDs are unlit, or if the LEDs are lit for two seconds or less and then turn off for at least one second. If an LED remains lit for longer than three seconds, that channel enters hard limiting where:

- Increases to the input level have no effect.
- Distortion increases due to clipping and nonlinear driver operation.
- The driver is subjected to excessive heat and excursion, which will compromise its life span and may eventually lead to damage over time.

 **CAUTION:** The Limit LEDs indicate when a safe, optimum level is exceeded. If a JM-1P loudspeaker begins to limit before reaching the required SPL, consider adding more loudspeakers to the system.

 **NOTE:** The JM-1P loudspeaker uses optical limiters that add no noise and have no effect on the signal when the limiters are not engaged and the Limit LEDs are not lit.

On/Temp LED

When the JM-1P is powered on, its On/Temp LED turns green. If the temperature of the heat sink reaches 85° C (185° F), the On/Temp LED changes from green to red and the limiter threshold is lowered to a safe level to prevent the system from overheating. Under high temperature conditions the output level is reduced by approximately 6 dB.

When the heat sink temperature decreases to 80° C (176° F), the On/Temp LED changes from red back to green and the limiter threshold returns to normal.

 **NOTE:** When the On/Temp LED is red, this is an indication that the unit is reaching its maximum dissipation and a reduction in SPL is recommended.

 **TIP:** When the JM-1P is connected to an RMS network, the RMS software provides additional feedback on the loudspeaker's operating temperature. For more information, see Chapter 6, "The RMS Remote Monitoring System."

AMPLIFIER COOLING SYSTEM

The amplifier for JM-1P uses natural convection for cooling at low to moderate audio levels; for high audio levels, it uses Meyer Sound's proprietary QuietCool fan technology to prevent overheating. The QuietCool™ fan only engages at high audio levels, making it virtually inaudible.



QuietCool Fan Technology

CAUTION: The heat sink for the JM-1P can reach temperatures of up to 85° C (185° F) during extreme operation. Use extreme caution when approaching the rear of the loudspeaker.

CAUTION: To keep the JM-1P from getting too hot, allow for proper ventilation around the loudspeaker, especially when it is operated in tightly packed conditions.

CAUTION: In the unlikely event that the heat sink temperature for the JM-1P reaches 95° C (203° F), the loudspeaker will automatically shut down until AC power is removed to allow the heat sink to cool. If after cooling and reapplying AC power the loudspeaker shuts down again, contact Meyer Sound for repair information.

CHAPTER 4: ADDING SUBWOOFERS TO A JM-1P LOUDSPEAKER SYSTEM

700-HP subwoofers can be added to JM-1P loudspeaker systems to enhance the low-frequency response and increase the overall acoustic power of the system in the lowest frequencies. The ideal ratio of JM-1P loudspeakers to 700-HP subwoofers depends on the frequency content of the source material and headroom required for low frequencies.

Table 2: Recommended Ratio of JM-1Ps to Subwoofers

Sub-woofer	Frequency Response	Recommended Ratio (Number of JM-1Ps per Subwoofer)
700-HP	30 Hz – 125 Hz ±4 dB	<ul style="list-style-type: none"> ■ 2 x 1 for normal applications ■ 3 x 2 for bass-heavy applications requiring additional low-frequency headroom

700-HPs can be added to JM-1P systems by daisy-chaining them to JM-1P loudspeakers. Full-range signals can be connected directly to Meyer Sound self-powered loudspeakers because the loudspeakers have built-in active crossovers. In more complex systems, subwoofers should be integrated using line drivers or digital signal processor to send multiple outputs to each sub-system. In addition, you can use low-cut filters to flatten the overall frequency response of the system while increasing the JM-1P headroom in the lower frequencies.

NOTE: When JM-1P loudspeakers and 700-HP subwoofers are daisy-chained using the JM-1P's Loop connector, the result is a fairly flat frequency response. However, the response will show an increase in the 60 Hz – 200 Hz range where the loudspeaker and subwoofer overlap at certain ratios (see Table 2).

NOTE: If the 700-HP exhibits limiting (its Limit LED lights) before reaching the required SPL, consider adding more subwoofers to meet the SPL requirements without exposing the drivers to excessive heat and excursion.

TIP: MAPP Online Pro™ can be used to accurately predict the appropriate loudspeaker and subwoofer integration in systems, complete with coverage data, system delay and equalization settings, rigging information, and detailed design illustrations. For more information, see “MAPP Online Pro” on page 31.

THE GALILEO LOUDSPEAKER MANAGEMENT SYSTEM

Meyer Sound's Galileo® loudspeaker management system is a comprehensive solution for driving and aligning loudspeaker systems, especially those comprised of Meyer Sound self-powered loudspeakers. The system is available in two hardware configurations:

- The Galileo 616 is a two-space rack unit with six inputs and 16 low-latency outputs. Processing for the outputs includes gain, polarity, delay, high- and low-pass filters, equalization (parametric and TruShaping), and atmospheric correction.

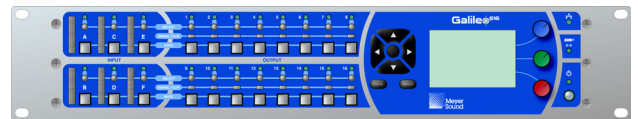

Galileo 616

- The Galileo 408 shares the same 24-bit, 96 kHz audio quality and 32-bit floating point internal processing as the Galileo 616, though with fewer inputs and outputs.



Galileo 408

All system parameters for the Galileo 616 and Galileo 408 can be configured from the extensive Compass™ software running on a Windows or Mac® computer. The Galileo 616 can also be configured from its intuitive front panel controls.

The Galileo system interfaces seamlessly with Meyer Sound's SIM® 3 audio analyzer.

TIP: The Galileo 616 and Galileo 408 include presets optimized for JM-1P loudspeaker systems.

USING DIGITAL SIGNAL PROCESSORS

Full-range signals can be connected directly to Meyer Sound self-powered loudspeakers because the loudspeakers have built-in active crossovers. External crossovers and digital signal processors are optional and should be used with caution as they can introduce phase shifts that cause destructive cancellations.

If a digital signal processor is used, both the JM-1P loudspeakers and subwoofer should be driven from the same processor to keep their delay times the same. Otherwise a phase shift between the JM-1Ps and subwoofer may be encountered. In addition, you should verify the delay time between channels: some digital signal processors may incur channel-to-channel delays when the processor is near maximum throughput, which becomes more likely as the number of filters in use by the processor is increased.

Third-order filters (and higher) are not recommended. If they must be used, they should be used cautiously, since they may cause phase shifts that deteriorate the impulse response; in addition, their higher roll-off may also interfere with crossover interaction.



TIP: To address the collective concerns of system design verification, subwoofer integration, digital signal processors, delay systems, and acoustical conditions, a measurement system like Meyer Sound's SIM 3 is strongly recommended.

CHAPTER 5: QUICKFLY RIGGING

The JM-1P loudspeaker is compatible with Meyer Sound's QuickFly system, a comprehensive collection of custom-designed rigging, flying, and mounting options. Comprised of rugged, reliable, and easy-to-configure components, QuickFly lets you deploy JM-1P loudspeakers as arrays at precise angles to take full advantage of their directional components. The top and bottom plates for the JM-1P cabinets are constructed of heavy-duty, high-strength, corrosion-resistant 6061-T6 aluminum and include threaded metric holes (for M10 screws) for easy connection to QuickFly rigging and third-party mounting options.

Important Safety Considerations!

When installing Meyer Sound loudspeakers, the following precautions should always be observed:

- All Meyer Sound products must be used in accordance with local, state, federal, and industry regulations. It is the owner's and user's responsibility to evaluate the reliability of any rigging method for their application. Rigging should only be carried out by experienced professionals.
- Use mounting and rigging hardware that has been rated to meet or exceed the weight being hung.
- Make sure to attach mounting hardware to the building's structural components (studs or joists), and not just to the wall surface. Verify that the building's structure and the anchors used for the installation will safely support the total weight of the mounted loudspeakers.
- Use mounting hardware appropriate for the surface where the loudspeaker will be installed.
- Make sure bolts and eyebolts are tightened securely. Meyer Sound recommends using Loctite® on eyebolt threads and safety cables.
- Inspect mounting and rigging hardware regularly. Immediately replace any worn or damaged components.

THE JM-1P GUIDEALINKS

The JM-1P is equipped with GuideALinks on its four right corners that attach to an adjacent JM-1P with the links inserted in the left corner slots of the linked unit. GuideALinks are extended and retracted with front and rear knobs. The links are secured to the linked JM-1P with the quick-release pins included with each loudspeaker. GuideALinks are also used when flying JM-1Ps from the MTG-JM1 vertical grid.

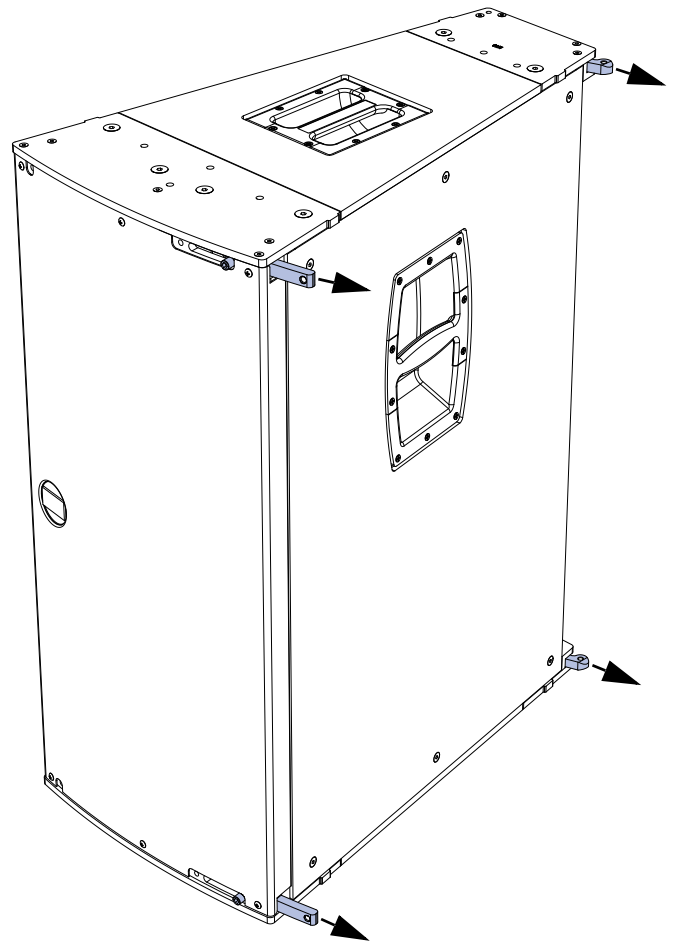

JM-1P GuideALinks

 **CAUTION:** When moving and linking JM-1Ps, avoid placing fingers between the units to prevent injury.

The JM-1P Quick-Release Pins

Each JM-1P ships with four quick-release pins that secure the units when they are linked. When inserting and removing the pins, press the button at the top of the pin to disengage it. When inserted in the GuideALink holes (in the front left corners and rear right corners), the pins latch and lock to the links inserted into the corner slots.

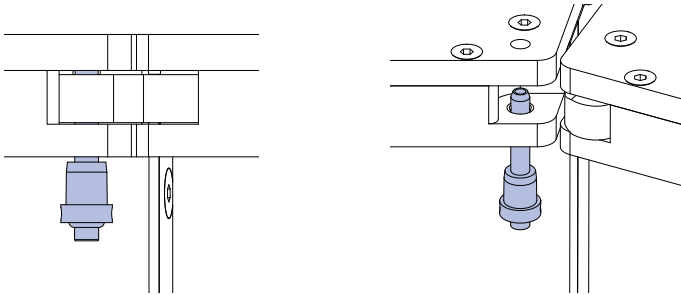

Rear Quick-Release Pin, GuideALink Inserted (Left); GuideALink Not Present (Right)

When the GuideALinks are not present in the corner slots, the quick-release pins should be removed from the corner link holes and placed in their stowed location: in the front, just to the left of the top and bottom GuideALink knobs; and in the rear, in the top and bottom center holes.

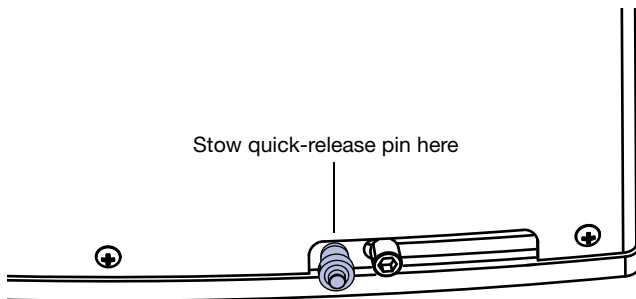

Stowed Quick-Release Pin, Front Bottom

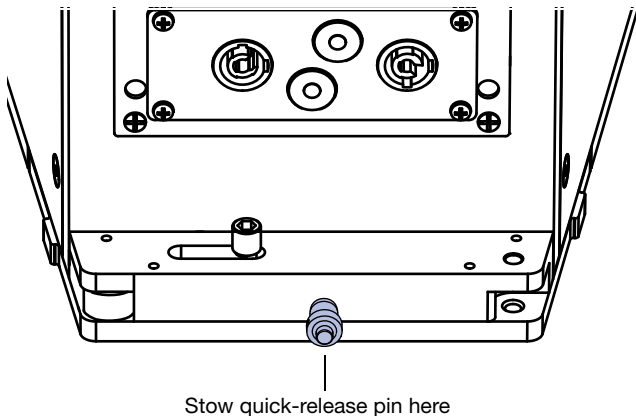

Stowed Quick-Release Pin, Rear Bottom

Linking JM-1Ps

To link JM-1Ps:

1. Place the JM-1Ps next to each other on a flat surface and align the adjacent back corners so they are as close as possible to each other.

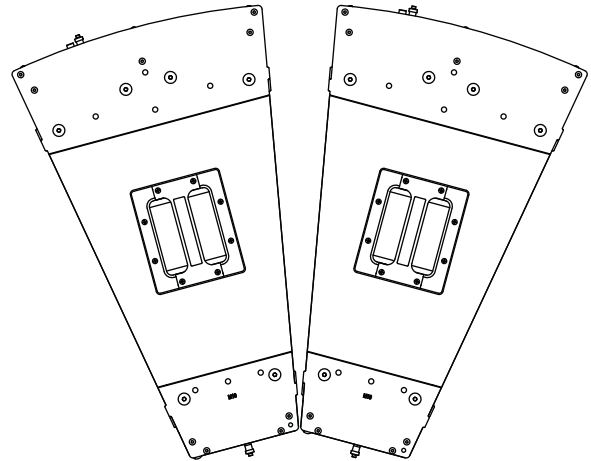

2. Face the rear of the loudspeakers and slide the top and bottom rear GuideALink knobs to the left to insert the links into the corner slots of the adjacent loudspeaker.

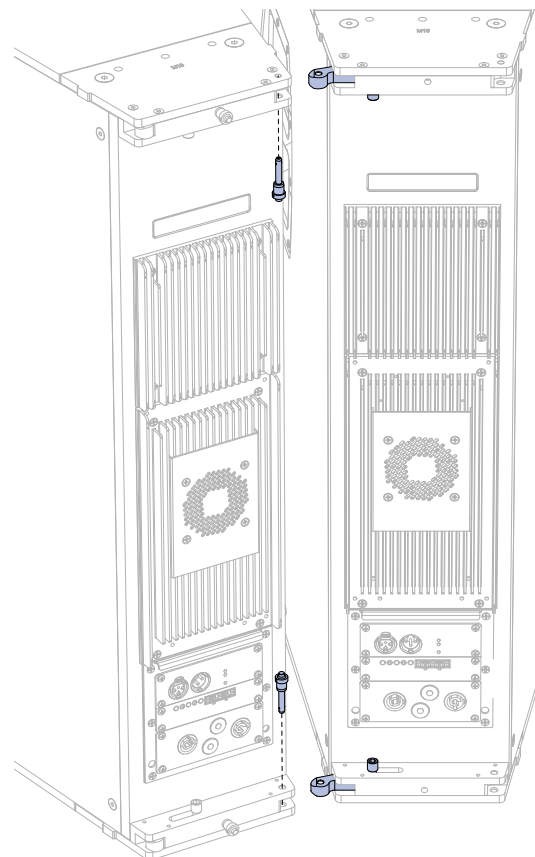

- Secure the rear GuideALinks with the quick-release pins stored at the center top and center bottom of the loudspeaker. The pins can be inserted top down or bottom up.
- Face the front of the loudspeakers and position the loudspeakers so their adjacent front corners are as close as possible to each other. The previously attached rear GuideALinks act as a hinge.
- Slide the top and bottom front GuideALink knobs to the right to insert the links into the corner slots of the adjacent loudspeaker.



- Secure the front GuideALinks with the quick-release pins stored at the right top and right bottom of the loudspeaker. The pins are inserted from the front.



CAUTION: Routine maintenance inspections of the JM-1P should include a check of all GuideALink knobs. Rotate each knob counterclockwise to make sure they are tight. If a knob turns, reset it in the link with Loctite 290 and let it cure for 48 hours. Retest the link before the unit is flown.

THE MPA-JM1 PICKUP PLATE

The optional MPA-JM1 pickup plate suspends JM-1P horizontal arrays with uptilt or downtilt. A single pickup plate supports 1–4 loudspeakers. Two pickup plates support 5–6 loudspeakers. The pickup plate comes with M10 knobs, bolts, and washers for securing the plate to the JM-1P. Bolts are recommended for fixed installations, while knobs are recommended for touring and portable applications.

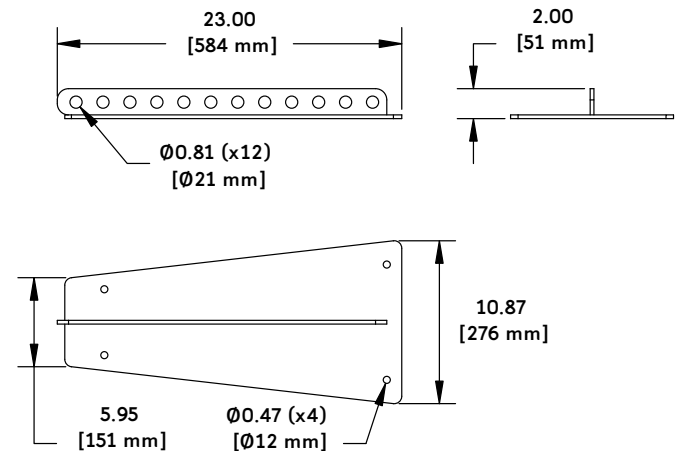

MPA-JM1 Pickup Plate Dimensions; Weight, 16 lbs (7.26 kg)

The MPA-JM1 has a row of 12 hanging points in the center of the plate. When suspending the pickup plate from a single hanging point, the location of the hanging point determines the uptilt or downtilt of the suspended JM-1Ps. For greater control, two or more hanging points can be used.

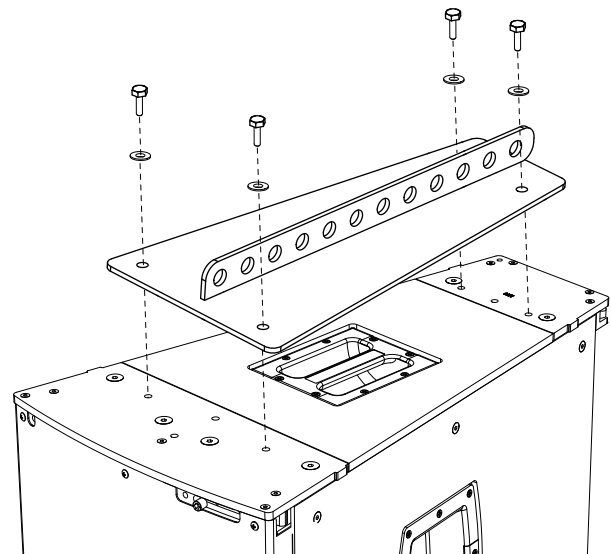

MPA-JM1 Pickup Plate with JM-1P

 **NOTE:** When using M10 knobs to secure the MPA-JM1 pickup plate to the JM-1P, the second hanging point from the rear is inaccessible.

JM-1P Arrays with a Single Pickup Plate

A single MPA-JM1P pickup plate can suspend arrays of 2–4 loudspeakers:

- For arrays of two JM-1Ps (with 40 degrees of horizontal coverage), attach the single pickup plate between the two loudspeakers.

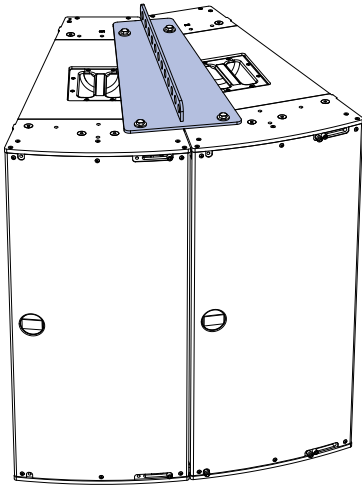

MPA-JM1 Pickup Plate with Two JM-1Ps

- For arrays of three JM-1Ps (with 60 degrees of horizontal coverage), attach the single pickup plate to the second loudspeaker.

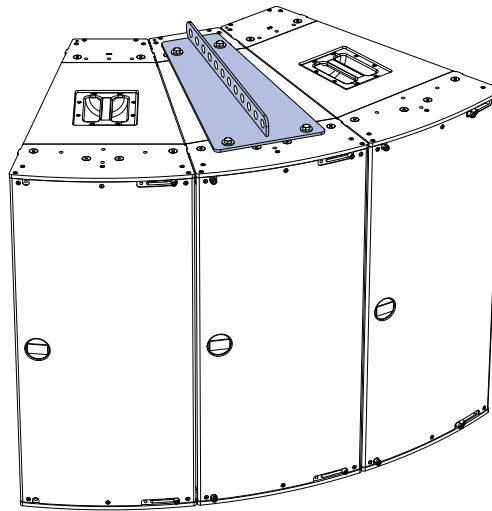

MPA-JM1 Pickup Plate with Three JM-1Ps

- For arrays of four JM-1Ps (with 80 degrees of horizontal coverage), attach the single pickup plate between the third and fourth loudspeaker.

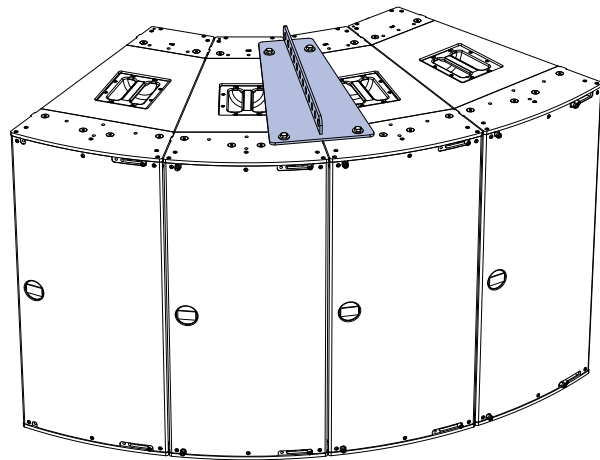

MPA-JM1 Pickup Plate with Four JM-1Ps

 **TIP:** For greater control and stability, use two MPA-JM1 pickup plates for arrays of four JM-1Ps.

JM-1P Arrays with Two Pickup Plates

Two MPA-JM1 pickup plates can suspend arrays of 4–6 loudspeakers:

- For arrays of four JM-1Ps (with 80 degrees of horizontal coverage), attach the two pickup plates between the first and second, and third and fourth loudspeakers.

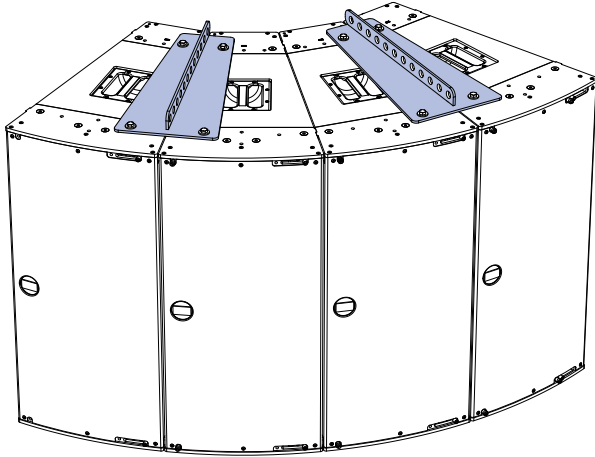

Two MPA-JM1 Pickup Plates with Four JM-1Ps

- For arrays of five JM-1Ps (with 100 degrees of horizontal coverage), attach the two pickup plates to the second and fourth loudspeakers.

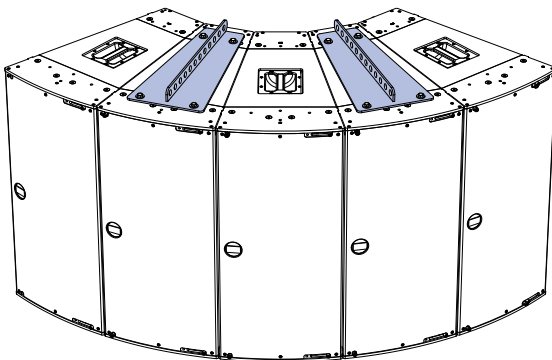

Two MPA-JM1 Pickup Plates with Five JM-1Ps

- For arrays of six JM-1Ps (with 120 degrees of horizontal coverage), attach the two pickup plates to the second and fifth loudspeakers.

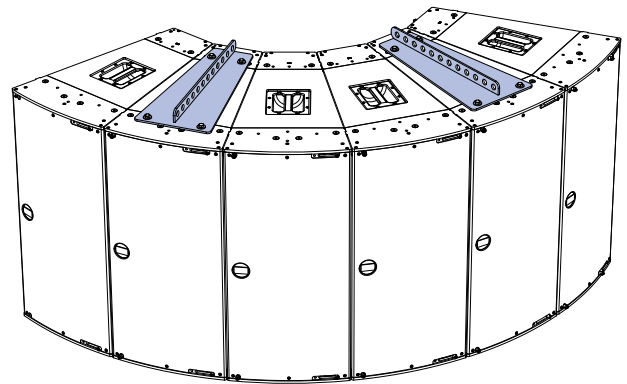

Two MPA-JM1 Pickup Plates with Six JM-1Ps

The MTGSB-4B Spreader Bar

The optional MTGSB-4B spreader bar can suspend two MPA-JM1P pickup plates from a single motor point. Six hanging points are provided at each end of the spreader bar to adjust the spread between the pickup plates. The MTGSB-B spreader bar includes shackles and connecting links.

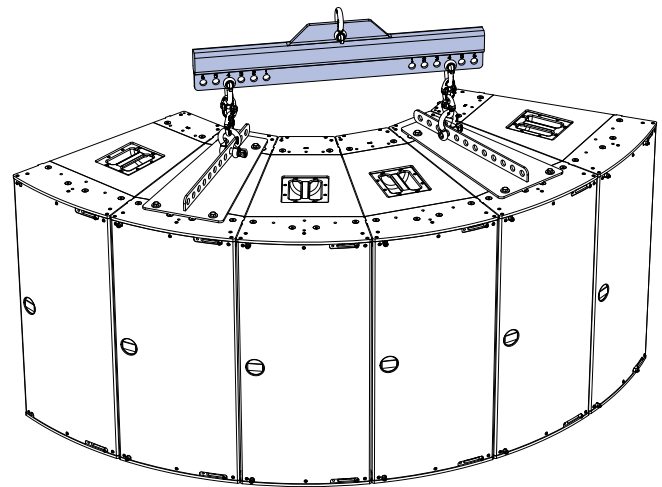

Two MPA-JM1 Pickup Plates with Six JM-1Ps Suspended from the MTGSB-4B Spreader Bar

THE MTG-JM1 VERTICAL GRID

The optional MTG-JM1 vertical grid suspends JM-1P vertical arrays of up to six units. The grid was designed specifically for the JM-1P and is compatible with the GuideALinks and quick-release pins included with the JM-1P.

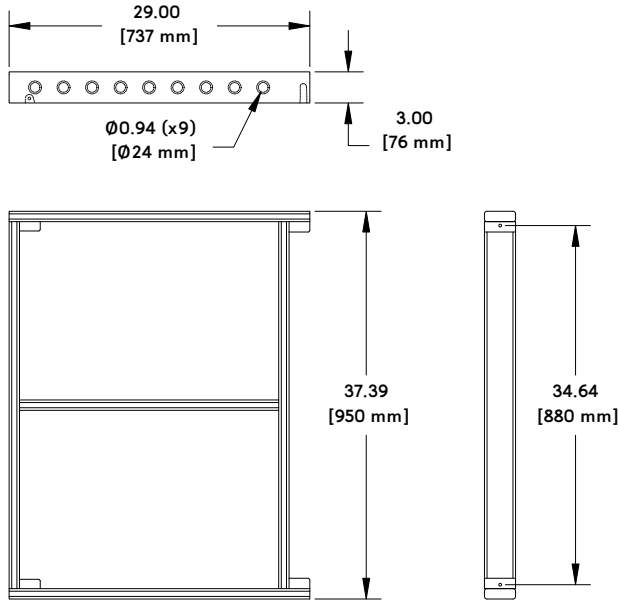

MTG-JM1 Vertical Grid Dimensions; Weight, 47 lbs (21.32 kg)

The MTG-JM1 vertical grid comes with four quick-release pins for securing the JM-1P connected directly to the grid. To secure the front GuideALinks, the quick-release pins are inserted at the front of the grid. To secure the rear GuideALinks, the pins are inserted from the inside of the grid. Additional JM-1Ps in the array are secured with the quick-release pins included with each loudspeaker.

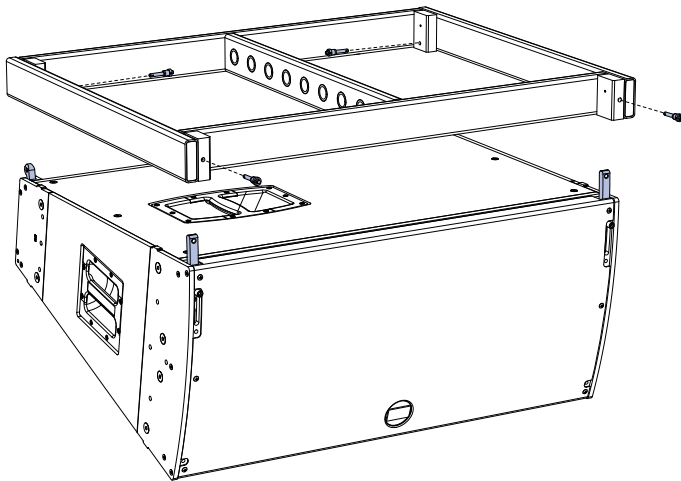

MTG-JM1 Vertical Grid with JM-1P

The MTG-JM1 vertical grid has a row of nine hanging points in the center of the grid. Two additional attachment points are located at the left and right rear corners of the grid to provide additional control and stability.

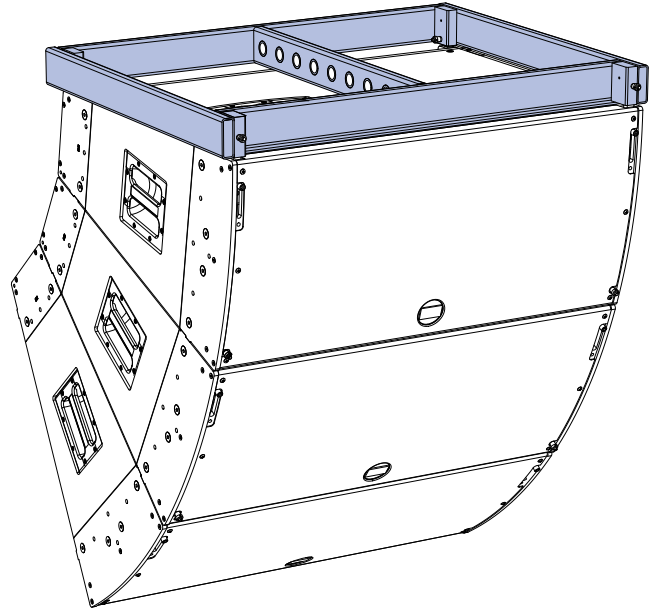

MTG-JM1 Vertical Grid with Three JM-1Ps

Rotating the Meyer Sound Logo

To accommodate the orientation of the JM-1P, the Meyer Sound logo on the unit's grille frame can be rotated.

To rotate the Meyer Sound logo on the JM-1P grille frame:

- Pull up on the logo, rotate it to the desired position, and release.

THE MDB-JM1 DOLLY BOARD

The optional MDB-JM1 dolly board transports the JM-1P on caster wheels. Up to three dolly boards can be interlocked for transporting up to three linked JM-1Ps. The interlocked dolly boards can be oriented normally with all three units facing the same direction, or they can be staggered to occupy less space during transport.

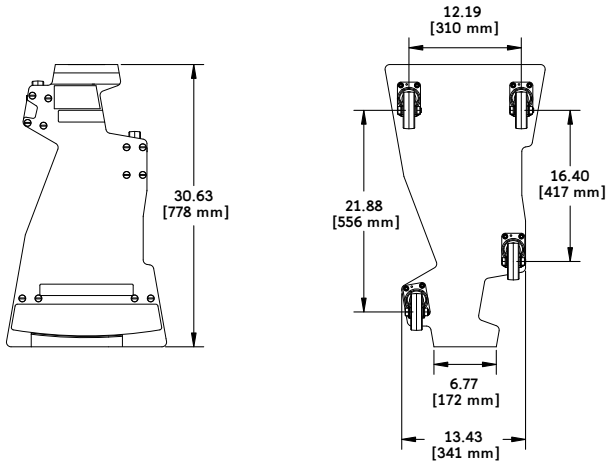

MDB-JM1 Dolly Board Dimensions

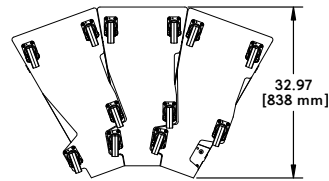
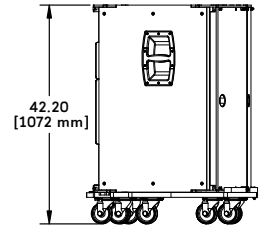
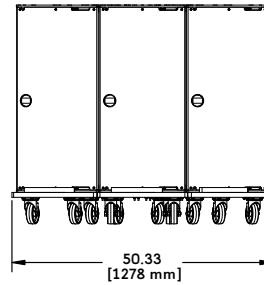
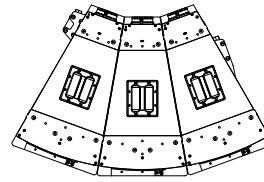

Dimensions for Three MDB-JM1 Dolly Boards, Normal

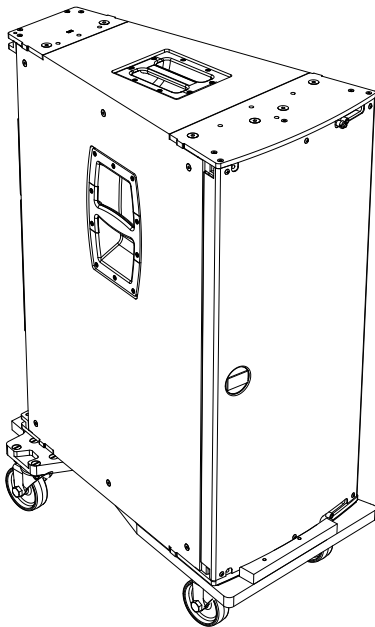

MDB-JM1 Dolly Board with JM-1P

 **TIP:** The JM-1Ps can remain in their MDB-JM1 dolly boards during performances. When doing so, make sure the boards' wheels are securely blocked so the units won't move their positions.

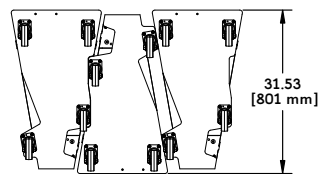
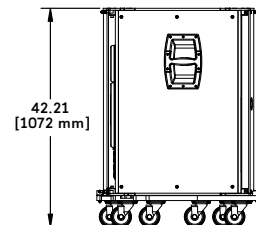
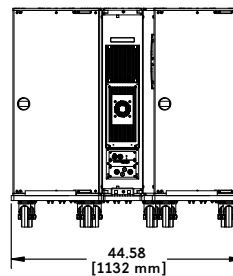
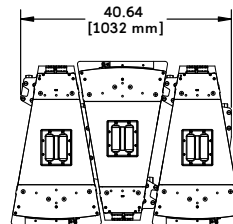



Dimensions for Three MDB-JM1 Dolly Boards, Staggered

CHAPTER 6: THE RMS REMOTE MONITORING SYSTEM

An optional RMS remote monitoring system module can be installed in the JM-1P, allowing it to be connected to an RMS network. RMS allows real-time monitoring of multiple Meyer Sound self-powered loudspeakers from a Windows-based computer. The RMS host computer communicates with Meyer Sound loudspeakers (equipped with RMS modules) via a simple twisted pair network, or an Ethernet network using an FT-10 to Ethernet adapter.

 **NOTE:** For the latest RMS system requirements, go to the Meyer Sound website (<http://www.meyersound.com>).

 **NOTE:** RMS-equipped loudspeakers include a Mute Jumper that can be installed to enable the loudspeaker's mute and solo capability. Meyer Sound currently ships RMS-equipped loudspeakers with the Mute Jumper installed. These mute-enabled loudspeakers can be identified by the blue "ME" sticker on the face of the RMS module. Older RMS-equipped loudspeakers can easily be mute-enabled by installing the Mute Jumper. For more information, refer to the *RMS User Guide*.

 **NOTE:** The RMS software allows you to disable Mute and Solo functions to eliminate any possibility of accidentally muting loudspeakers. Mute and solo capability can also be disabled by removing the Mute Jumper from RMS modules. For more information, refer to the *RMS User Guide*.

 **NOTE:** RMS does not control AC power.

THE RMS SOFTWARE

The optional RMS software provides extensive system status and performance data for each loudspeaker, including amplifier voltage, limiting activity, power output, driver status, as well as mute and solo capability. Loudspeakers are added to the RMS network and assigned a node name during a one-time commissioning procedure where the loudspeaker is identified by either entering its unique Neuron ID, or by pressing its Service button.

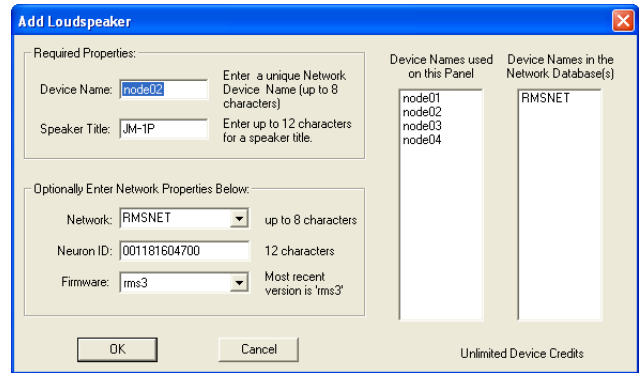

RMS Add Loudspeaker Dialog Box

Once loudspeakers are identified on the RMS network, they appear in the RMS software as icons and views; they are also automatically added to the RMS database on the host computer.



JM-1P RMS Icon

The RMS software displays all loudspeakers on the network in a panel with icons, Meter views, and Text views that can be customized to suit your needs. Loudspeaker data is updated 2–5 times per second. Individual loudspeakers can be physically identified with the Wink option in RMS, which lights the Wink LED on the RMS module for that particular loudspeaker. Conversely, a loudspeaker can be identified in the RMS software by pressing the Service button on the loudspeaker's RMS module.

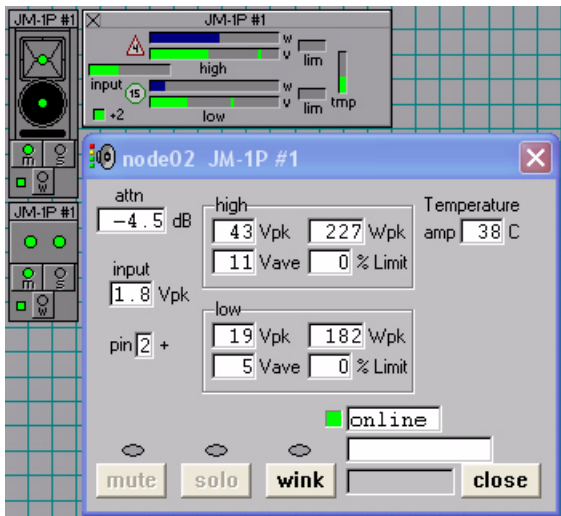

RMS User Panel

Loudspeaker icons and views can be arranged to represent how the loudspeakers have been deployed in the system. Multiple panels can be saved and recalled for specific performances and venues.

NOTE: When the heat sink for the JM-1P reaches 85° C (185° F), the On/Temp LED turns red, while its loudspeaker icon in the RMS software turns yellow — indicating the loudspeaker is running hot, but still within safe operating limits. Make sure that the loudspeaker is properly ventilated.

THE RMS MODULE

The RMS module is installed in the bottom slot of the user panel on the back of the Meyer Sound loudspeaker. The RMS user panel has three LEDs, two buttons, and two Network connectors.



RMS Module

NOTE: The LEDs and buttons on the RMS user panel are used exclusively by RMS and have no effect on the acoustical or electrical activity of the JM-1P loudspeaker.

Service LED (Red)

The red Service LED provides the following feedback:

- When unlit, the loudspeaker is successfully connected to the network and commissioned.
- When blinking once every two seconds, the loudspeaker is connected to the network but not yet commissioned in the RMS software.
- When lit continuously, the loudspeaker's RMS hardware has failed and may indicate that the module has been damaged (contact Meyer Sound Technical Support).

NOTE: The Service LED on the RMS user panel is used exclusively by RMS and has no effect on the acoustical or electrical activity of the JM-1P loudspeaker.

Service Button

Pressing the Service button identifies the loudspeaker on the RMS network and notifies the RMS software that the loudspeaker is connected. You can simultaneously press the Reset and Service buttons to reset the RMS module and decommission the loudspeaker from the network (see “Resetting the RMS Module” on page 29).

Wink LED (Green)

The green Wink LED lights when a signal is sent from the RMS software by clicking the Wink button on the loudspeaker's icon or on its Text view. This is useful for identifying the physical loudspeaker corresponding to a loudspeaker icon in the RMS software.

Reset Button

Pressing the Reset button causes the RMS module's firmware to reboot; this will not affect whether the loudspeaker is commissioned (which is stored in flash memory). You can simultaneously press the Reset and Service buttons to reset the RMS module and decommission the loudspeaker from the network (see "Resetting the RMS Module" on page 29).

Activity LED (Green)

The green Activity LED flashes continuously when the loudspeaker has been successfully commissioned.

Network Connectors

The two bi-directional Weidmuller locking connectors transfer data to and from the RMS network. Two connectors are provided to allow for easy connection of multiple (daisy-chained) loudspeakers on the network.

RESETTING THE RMS MODULE

You can use the Reset and Service buttons to reset the RMS module, which will cause the module to be decommissioned from the network.

To reset the RMS module:

1. Press and hold the Service button for 10 seconds.
2. While continuing to hold down the Service button, press and hold the Reset button for 5 seconds.
3. After releasing the Reset button, continue holding down the Service button for 5 seconds. The RMS module is reset and the loudspeaker is decommissioned. The RMS module's red Service LED blinks.

CHAPTER 7: SYSTEM DESIGN AND INTEGRATION TOOLS

Meyer Sound offers two comprehensive tools to assist with the acoustical and functional requirements of system design and optimization. This chapter introduces you to MAPP Online Pro, Meyer Sound's patented online acoustical prediction tool, and SIM 3, a comprehensive system for measurement and analysis.

MAPP ONLINE PRO

MAPP Online Pro is a powerful, cross-platform, Java-based application for accurately predicting the coverage pattern, frequency response, impulse response, and maximum SPL output of single or arrayed Meyer Sound loudspeakers.

Residing on your local computer, the MAPP Online Pro client lets you configure Meyer Sound loudspeaker systems and define the environment in which they will operate, including air temperature, pressure, humidity, and even the location and composition of walls. CAD (DXF) files containing detailed venue information can also be imported.

detailed design illustrations. MAPP Online Pro's accurate, high-resolution predictions ensure that systems will perform as expected, thereby eliminating unexpected coverage problems and minimizing on-site adjustments.

The key to the accuracy of MAPP Online Pro's predictions is its exhaustive database of Meyer Sound loudspeaker measurements. Performance predictions for each loudspeaker are based on 360 1/48th-octave-band measurements taken with a SIM audio analyzer in the Meyer Sound anechoic chamber. The extraordinary consistency between Meyer Sound loudspeakers guarantees that predictions from MAPP Online Pro will closely match their actual performance.

MAPP Online Pro predictions are requested by the client software and sent via the Internet to the high-speed Meyer Sound servers where high-resolution (magnitude and phase) polar data is processed with sophisticated acoustical prediction algorithms. The resulting predictions are then returned to and displayed on the local computer running the MAPP Online Pro client software.

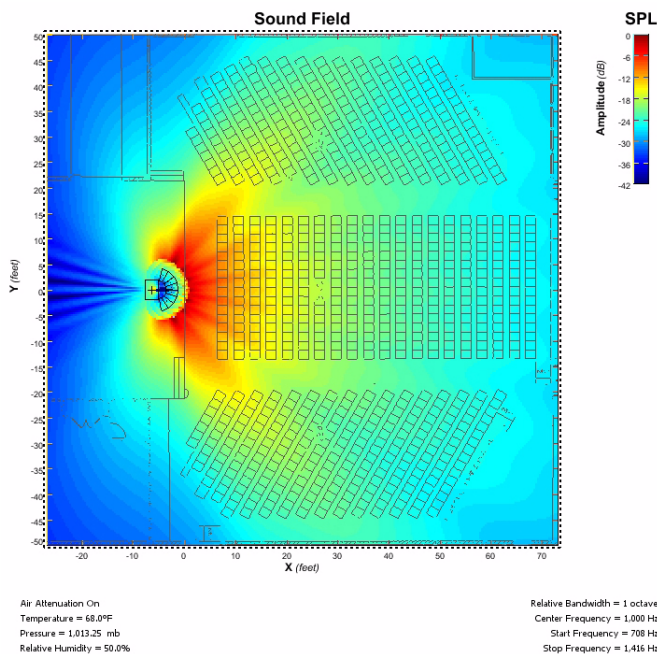

MAPP Online Pro

Whether planning for fixed installations or tours with multiple venues, sound system designers can use MAPP Online Pro to accurately predict the appropriate loudspeaker deployment for each job, complete with coverage data, system delay and equalization settings, rigging information, and

MAPP Online Pro Applications

With MAPP Online Pro, you can:

- Simulate different loudspeaker configurations to refine system design and zero-in on the best coverage for intended audience areas
- Monitor loudspeaker interactions to locate destructive interferences so that loudspeakers can be re-aimed and repositioned as necessary
- Place microphones anywhere in the sound field and predict their frequency response, impulse response, and sound pressure
- Determine delay settings for fill loudspeakers
- Try out virtual Galileo equalization to determine optimum real-world settings for the best system response
- Automatically calculate load information for arrays to determine rigging capacities, front-to-back weight distribution, and center of gravity
- Generate and export system images for client presentations

Using MAPP Online Pro

MAPP Online Pro is compatible with the following operating systems:

- Windows
- Linux®
- Unix®
- Mac OS® 10.4 or later

Additional system requirements and recommendations are available on the MAPP Online Pro website:

<http://www.meyersound.com/products/mapponline/pro/>

Downloading and Installing MAPP Online Pro

To use MAPP Online Pro, you can register at the following link:

<http://www.meyersound.com/products/mapponline/pro/register/>

After entering your registration information, an email will be sent to you with your user name, password, and the MAPP Online Pro download location. On-screen instructions will guide you through the download and installation process.

The MAPP Online Pro client software is regularly upgraded to add support for the latest Meyer Sound loudspeakers, as well as to add feature enhancements. Most upgrades are downloaded automatically when logging on to a MAPP Online Pro session. The MAPP Online Pro database includes nearly all of the current Meyer Sound loudspeakers, subwoofers, and processors.

THE SIM 3 MEASUREMENT SYSTEM

The SIM 3 audio analyzer is a high-resolution audio measurement system comprised of software, hardware, microphones, and accessory cables. SIM 3 is optimized for measuring audio frequencies with resolutions up to 1/48th of an octave, allowing you to apply precise corrections to balance system response using frequency and phase domain information.

Source Independent Measurement Technique

The SIM 3 audio analyzer implements Meyer Sound's source independent measurement technique, a dual-channel method that accommodates statistically unpredictable excitation signals. Any excitation signal within a desired frequency range can be used to obtain highly accurate measurements for acoustical or electronic systems. For example, concert halls and loudspeaker systems can be captured during a performance and used as a SIM 3 test signal, so you can:

- View measurement data as amplitude versus time (impulse response) or amplitude and phase versus frequency (frequency response)
- Utilize a single-channel spectrum mode
- View frequency domain data with a logarithmic frequency axis
- Determine and internally compensate for propagation delays using the SIM 3 Delay Finder

SIM 3 Applications

SIM 3's main applications are testing and aligning loudspeaker systems, which entails:

- Measuring propagation delays between subsystems to determine appropriate polarities and delay times
- Measuring variations in frequency response caused by the acoustical environment and the placement and interaction of loudspeakers to determine corrective equalization
- Optimizing subwoofer integrations
- Optimizing loudspeaker arrays

SIM 3 can also be used in the following applications:

- Microphone calibration and equalization
- Transducer evaluation and correction
- Echo detection and analysis
- Vibration analysis
- Architectural acoustics
- Underwater acoustics

APPENDIX A: OPTIONAL VEAM MULTIPIN CONNECTOR

The JM-1P can be ordered from the factory with a VEAM all-in-one connector. VEAM connectors consolidate AC power, audio, and RMS into a single cable, facilitating easy connections and quick setups.

JM-1P loudspeakers require a grounded outlet. It is very important that the system be properly grounded in order to operate safely and properly. Figure 3 illustrates correct wiring for the creation of power cables and distribution systems for JM-1P loudspeakers equipped with VEAM multipin connectors.

For complete wiring conventions and pin-outs for AC, audio, and RMS connections, refer to the Meyer Sound document VEAM Cable Wiring Reference (PN 06.033.113.01).

Meyer Sound offers the VIM-4 VEAM interface module with four VEAM connectors in the front and a single-phase IEC 309 32-amp connector in the rear to distribute power, audio, and RMS to JM-1P loudspeakers equipped with VEAM connectors.

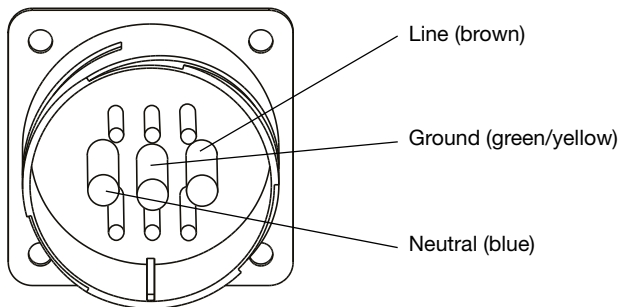
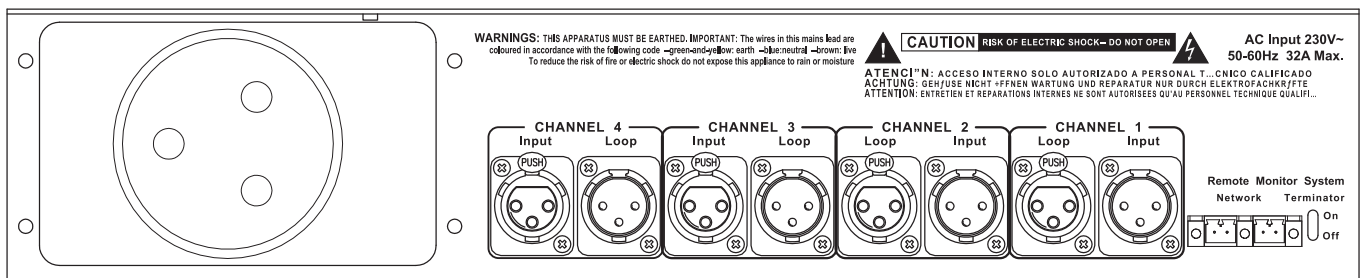
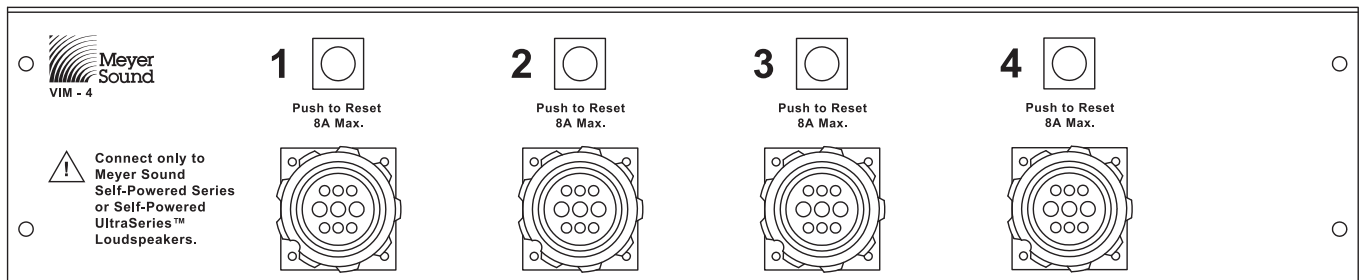

Figure 3: VEAM Multipin Connector Pin-Outs for Power



VIM-4 Module, Front and Rear Panels

APPENDIX B: OPTIONAL RAIN HOODS

A weather-protected version of the JM-1P is available with rain hood kits that safeguard the loudspeaker's electronics from the elements in fixed, outdoor installations. The rain hood is available in both vertical (PN 40.185.038.01) and horizontal (PN 40.185.084.02) versions. The rain hood kits are comprised of an upper rain hood that protects the heat sink, and a lower rain hood that protects the user panel and connectors. The rain hoods are made of a durable, high-impact polycarbonate that is also transparent, allowing the loudspeaker's connections and LEDs to be visible.

VERTICAL RAIN HOOD KIT CONTENTS

The JM-1P vertical rain hood is used when the loudspeaker is oriented vertically. The JM-1P vertical rain hood kit (PN 40.185.038.01) includes the following parts:

JM-1P Vertical Rain Hood Kit

Part	Part Number	Quant.
Upper rain hood assembly	45.185.084.02	1
Upper rain hood frame	45.185.084.01	1
Lower rain hood assembly	45.152.031.01	1
Flat head screws, 8-32 x .25"	101.827	4
Pan head screws, 8-32 x .50"	101.008	2
Lock pins, 5/16" x .63"	134.024	2

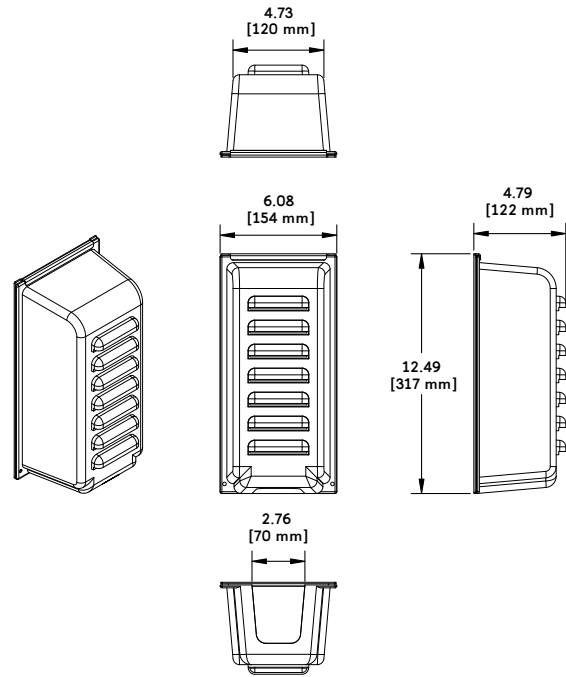

Vertical Rain Hood Dimensions: Upper Rain Hood Assembly (Right)

Installing the Vertical Rain Hood

To install the JM-1P vertical rain hood:

1. Attach any required cables to the loudspeaker and orient it vertically.
2. Remove the bottom two pan head screws from the amplifier face.

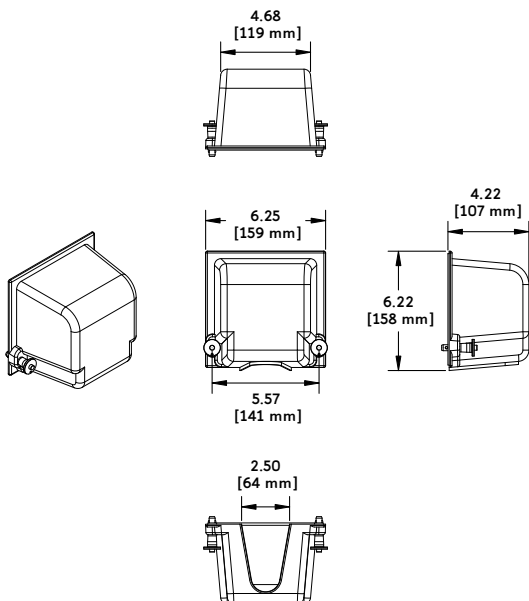

Vertical Rain Hood Dimensions: Lower Rain Hood Assembly

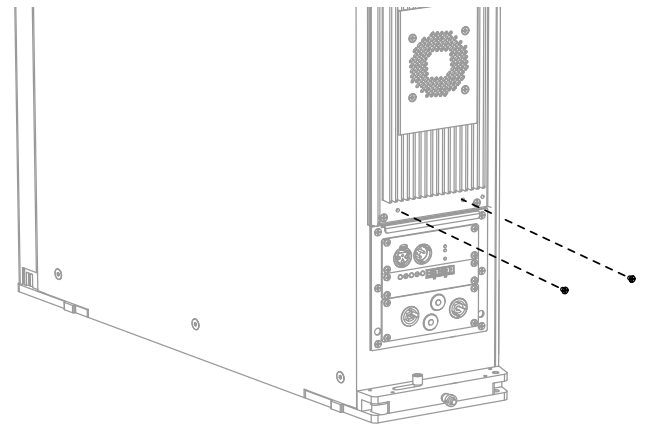

- Secure the upper rain hood frame to the amplifier face with the four 8-32 x .25 flat head screws, two at the top and two at the bottom.

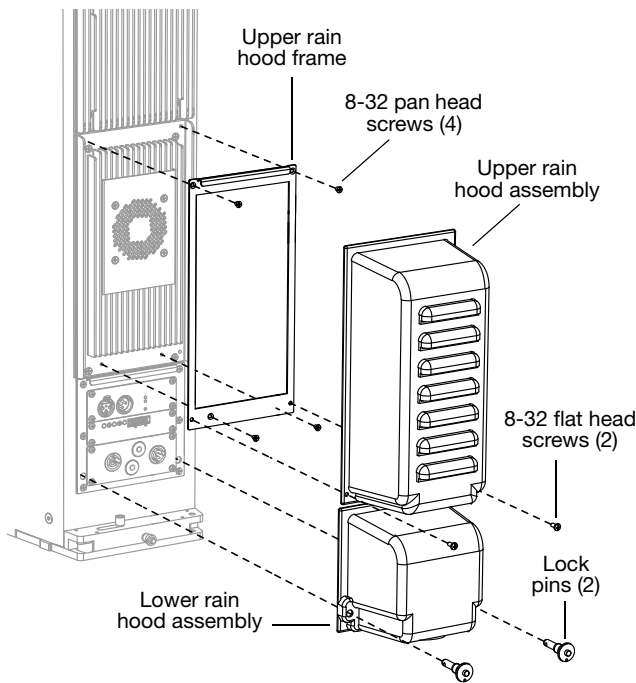

Figure 4: JM-1P Vertical Rain Hood Installation

- Attach the upper rain hood assembly to the upper rain hood frame, slipping it under the frame's top flange and securing it to the bottom of the frame with the two 8-32 x .50 pan head screws.
- Attach the lower rain hood assembly to the user panel, slipping it under the flange at the top of the user panel and securing it to the bottom of the panel with the two lock pins.

NOTE: The vertical rain hood should only be used when the loudspeaker is oriented vertically (see Figure 4).

NOTE: For permanent, fixed outdoor installations, both the lower and upper rain hood assemblies should be installed. For touring applications, the upper rain hood assembly can be removed, since the heat sinks and fan can be safely exposed to occasional rain. However, for all outdoor applications, the lower rain hood assembly should always be installed to shield the unit's connectors from rain.

HORIZONTAL RAIN HOOD KIT CONTENTS

The JM-1P horizontal rain hood is used when the loudspeaker is oriented horizontally. The JM-1P horizontal rain hood kit (PN 40.185.084.02) includes the following parts:

JM-1P Horizontal Rain Hood Kit

Part	Part Number	Quant.
Upper rain hood assembly	45.185.089.02	1
Upper rain hood frame	45.185.084.01	1
Lower rain hood assembly	45.185.090.01	1
Flat head screws, 8-32 x .25"	101.827	4
Pan head screws, 8-32 x .50"	101.008	2
Lock pins, 5/16" x .63"	134.024	2

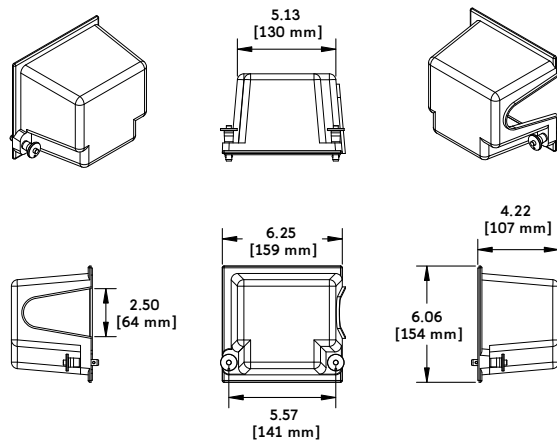

Horizontal Rain Hood Dimensions: Lower Rain Hood Assembly

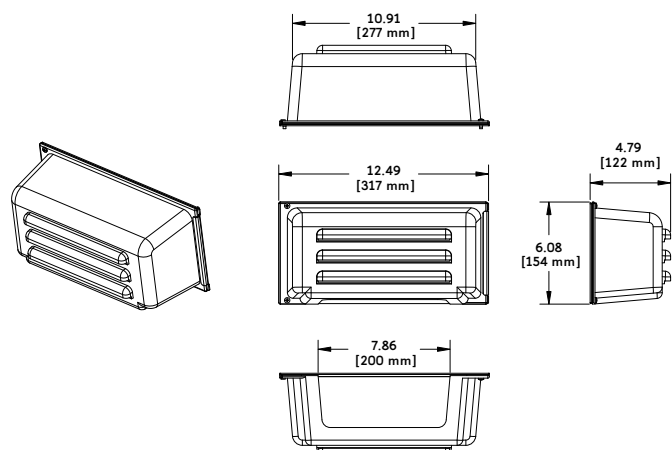

Horizontal Rain Hood Dimensions: Upper Rain Hood Assembly

Installing the Horizontal Rain Hood

To install the JM-1P horizontal rain hood:

1. Attach any required cables to the loudspeaker and orient it horizontally.
2. Remove the bottom two pan head screws from the amplifier face.

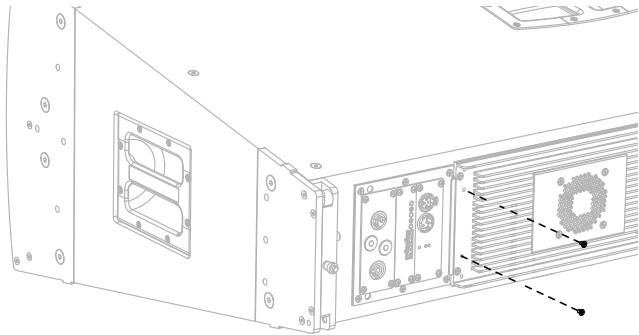

3. Secure the upper rain hood frame to the amplifier face with the four 8-32 x .25 flat head screws, two at the top and two at the bottom.

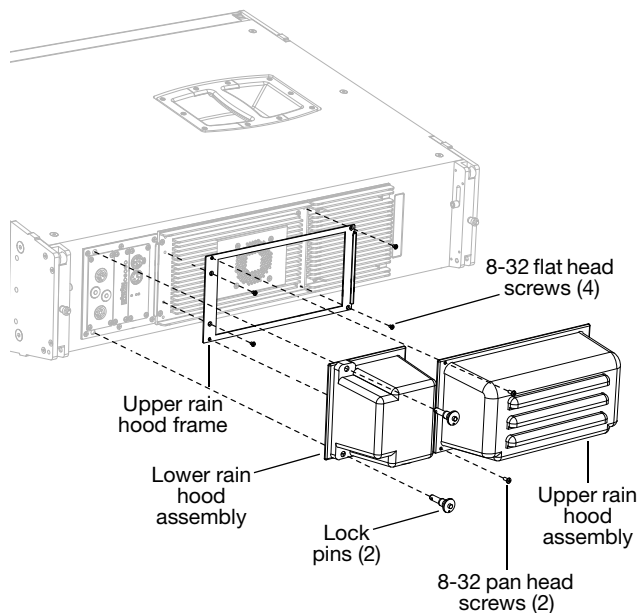



Figure 5: JM-1P Horizontal Rain Hood Installation

4. Attach the upper rain hood assembly to the upper rain hood frame, slipping it under the frame's top flange and securing it to the bottom of the frame with the two 8-32 x .50 pan head screws.

5. Attach the lower rain hood assembly to the user panel, slipping it under the flange at the top of the user panel and securing it to the bottom of the panel with the two lock pins.

 **NOTE:** The horizontal rain hood should only be used when the loudspeaker is oriented horizontally (see Figure 5).

 **NOTE:** For permanent, fixed outdoor installations, both the lower and upper rain hood assemblies should be installed. For touring applications, the upper rain hood assembly can be removed, since the heat sinks and fan can be safely exposed to occasional rain. However, for all outdoor applications, the lower rain hood assembly should always be installed to shield the unit's connectors from rain.

APPENDIX C: JM-1P SPECIFICATIONS

ACOUSTICAL	
Operating Frequency Range	53 Hz – 18 kHz Note: Recommended maximum operating frequency range. Response depends on loading conditions and room acoustics.
Frequency Response	56 Hz – 16.5 kHz \pm 4 dB Note: Measured free field with 1/3 octave frequency resolution at 4 meters.
Phase Response	580 Hz to 16 kHz \pm 45°
Maximum Peak SPL	138 dB Note: Measured with music referred to 1 meter.
Dynamic Range	>110 dB
Coverage	20° x 60°
Crossover	520 Hz Note: At this frequency, the transducers produce equal sound pressure levels.
TRANSDUCERS	
Low Frequency	One 15" cone driver with neodymium magnet Nominal impedance: 2 Ω Voice coil size: 4" Power-handling capability: 1200 W (AES) Note: Power handling measured using AES standards: transducer driven continuously for two hours with a band limited noise signal having a 6 dB peak-average ratio.
High Frequency	One 4" compression driver Nominal impedance: 8 Ω Voice coil size: 4" Diaphragm size: 4" Exit size: 1.5" Power-handling capability: 250 W (AES) Note: Power handling measured using AES standards: transducer driven continuously for two hours with a band limited noise signal having a 6 dB peak-average ratio.
AUDIO INPUT	
Type	Differential, electronically balanced
Maximum Common Mode Range	\pm 15 V DC, clamped to earth for voltage transient protection
Connectors	Female XLR input with male XLR loop output or VEAM all-in-one (integrates AC power, audio, and network)
Input Impedance	10 k Ω differential between pins 2 and 3
Wiring	Pin 1: Chassis/earth through 220 k Ω , 1000 pF, 15 V clamp network to provide virtual ground lift at audio frequencies Pin 2: Signal + Pin 3: Signal – Case: Earth ground and chassis
DC Blocking	Differential DC blocking up to maximum common mode voltage
CMRR	>50 dB, typically 80 dB (50 Hz – 500 Hz)
RF Filter	Common mode: 425 kHz Differential mode: 142 kHz
TIM Filter	<80 kHz, integral to signal processing

Nominal Input Sensitivity	0 dBV (1 V rms, 1.4 V peak) continuous average is typically the onset of limiting for noise and music
Input Level	Audio source must be capable of producing +20 dBV (10 V rms, 14 V peak) into 600 Ω to produce maximum peak SPL over the operating bandwidth of the loudspeaker

AMPLIFIER

Type	Two-channel complementary MOSFET output stages (class AB/H)
Output Power	1275 W total (1 x 1000 W, 1 x 275 W) Note: Wattage rating is based on the maximum unclipped burst sine-wave rms voltage the amplifier will produce into the nominal load impedance.
Total Output	2550 W peak Note: Peak power based on the maximum unclipped peak voltage that the amplifier will produce for at least 100 milliseconds into the nominal load impedance.
THD, IM TIM	<.02%
Load Capacity	2 Ω low channel, 8 Ω high channel
Cooling	Convection at low to mid audio levels; fan-assisted only at high audio levels Note: The fan is controlled by audio level, remaining off at turn-on and at low to mid audio levels and operating only at high audio levels, making it virtually inaudible.

AC POWER

Connectors	PowerCon with loop output or VEAM all-in-one (integrates AC power, audio, and network)
Voltage Selection	Automatic, two ranges, each with high-low voltage tap (uninterrupted)
Safety Agency Rated Operating Voltage	95–125 V AC; 208–235 V AC; 50/60 Hz
Turn On/Turn Off Points	85–134 V AC; 165–264 V AC

Note: No automatic turn-off voltages. Voltages above 265 V AC are fuse protected but may cause permanent damage to the power supply. Voltages below 90 V AC may result in intermittent operation.

Current Draw

Idle Current	0.50 A rms (115 V AC); 0.28 A rms (230 V AC); 0.56 A rms (100 V AC)
Maximum Long-Term Continuous Current	4.55 A rms (115 V AC); 2.50 A rms (230 V AC); 5.25 A rms (100 V AC)
Burst Current	8.0 A rms (115 V AC); 4.1 A rms (230 V AC); 9.2 A rms (100 V AC) Note: AC power cabling must be of sufficient gauge so that under burst current rms conditions, cable transmission losses do not drop voltage below specified operating range at the speaker.
Ultimate Short-Term Peak Current	20.8 A peak (115 V AC); 13.0 A peak (230 V AC); 21.6 A peak (100 V AC)
Inrush Current	7.1 A peak (115 V AC); 8.4 A peak (230 V AC); 7.1 A peak (100 V AC)

Note: Current draw for a single loudspeaker. Loop output not used.

PHYSICAL

Enclosure	Multi-ply hardwood
Finish	Black textured
Protective Grille	Hex-stamped steel with black mesh screen
Rigging	Aluminum end plates with side links for arraying units; threaded metric M10 points for rigging accessories; optional pickup plate and vertical grid for suspending arrays with uptilt or downtilt
Dimensions	16.79" w x 36.08" h x 29.30" d (427 mm x 916 mm x 744 mm)

Weight	Weight 147 lbs (66.68 kg)
ENVIRONMENTAL	
Operating Temperature	0° C to +45° C
Non Operating Temperature	<-40° C or >+75° C
Humidity	To 95% at 35° C
Operating Altitude	To 4600 m (15,000 ft)
Non operating Altitude	To 95% at 35° C
Shock	30 g 11 msec half-sine on each of 6 sides
Vibration	10 Hz – 55 Hz (0.010 m peak-to-peak excursion)

JM-1P COMPLIANCE



JM-1P DIMENSIONS

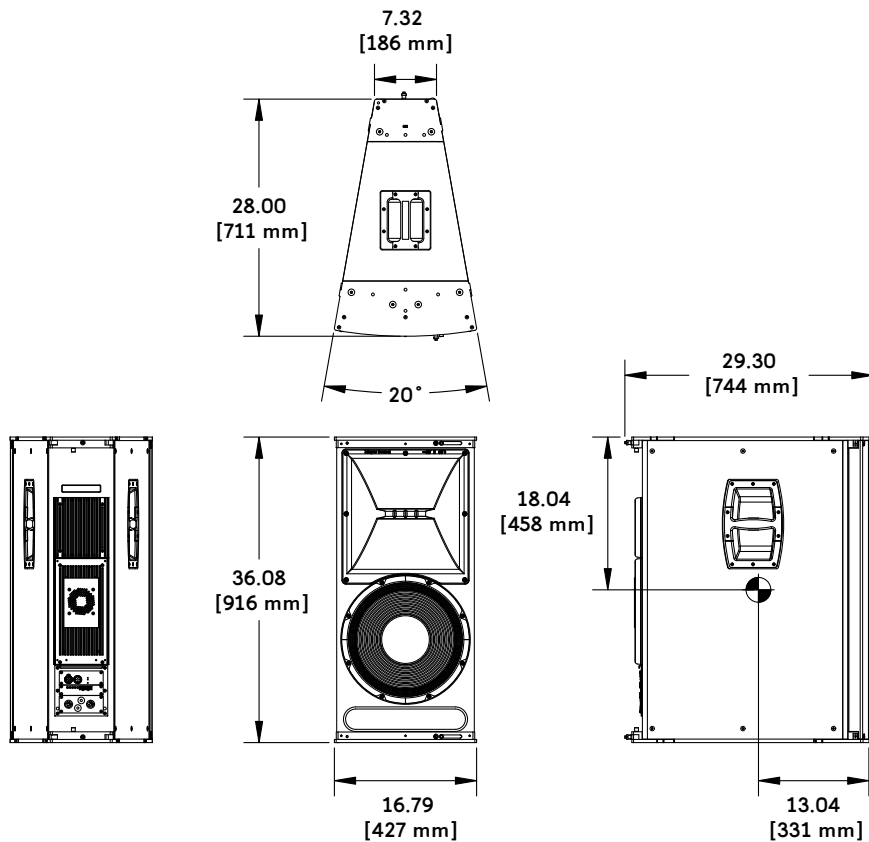

JM-1P Dimensions



thinking sound



Meyer Sound Laboratories Inc.
2832 San Pablo Avenue
Berkeley, CA 94702

www.meyersound.com
T: +1 510 486.1166

© 2009
Meyer Sound Laboratories Inc.
05.202.005.01 A

Free Manuals Download Website

<http://myh66.com>

<http://usermanuals.us>

<http://www.somanuals.com>

<http://www.4manuals.cc>

<http://www.manual-lib.com>

<http://www.404manual.com>

<http://www.luxmanual.com>

<http://aubethermostatmanual.com>

Golf course search by state

<http://golfingnear.com>

Email search by domain

<http://emailbydomain.com>

Auto manuals search

<http://auto.somanuals.com>

TV manuals search

<http://tv.somanuals.com>