

UM-1C

UltraMonitor™



Features

High gain-before-feedback

Ultra-low distortion

Ultra-flat frequency response

Rugged and reliable

Applications

Stage Monitoring

Clubs and concerts

Low-throw coverage

Fill coverage

The UltraMonitor delivers the final word on high-powered, critical monitoring. Specifically designed for touring reinforcement, the highly accurate, rugged UM-1C biamplified system consists of a proprietary 12-inch low-frequency driver in a vented enclosure, and a symmetrical pattern 45-degree high-frequency horn with driver.

The UM-1C proprietary drivers provide exceptional efficiency and power handling, with ultra-low distortion for high clarity. Very flat frequency response allows control of feedback at high sound levels.

The sturdy, multi-ply hardwood enclosure with textured finish withstands road abuse. The unit comes with handles and, optionally, aircraft-style rigging pan fittings.

The UltraMonitor requires a high-quality professional stereo power amplifier capable of delivering up to 250 watts per channel continuously into 8 ohms, with a signal voltage gain of 20dB (minimum) to 30dB (maximum).



Meyer Sound Laboratories, Inc.
2832 San Pablo Avenue
Berkeley, CA 94702
(510) 486-1166
FAX (510) 486-8356

M E Y E R S O U N D

UM-1C Specifications

Acoustical – UM-1C/M-1A System

Frequency Response ¹	70-18,000 Hz \pm 4 dB	
Maximum SPL ² with amplifier rated at:	250 W/8 ohms/ch.	60 W/8 ohms/ch.
Continuous	125 dB	120 dB
Peak	135 dB	126 dB
HF Coverage, -6dB points	45 degrees symmetrical	

UM-1C Loudspeaker

Transducers	
Low Frequency	MS-12 12-inch cone driver, 8 ohms
High Frequency	MS-1401B 1.4-inch throat driver, 16 ohms
High-Frequency Horn	45 degree constant-directivity
HF Network	Y-1PD
Function	DC blocking and passive filters with alternate connection terminal to adjust VHF response (16k peak or flat)
Enclosure	0.8 cu. ft. vented, multi-ply Finnish birch
Finish	Black textured
Protective Grill	Perforated steel screen, charcoal-grey foam covering
Connector	Cannon EP-4 male, EP-5 male (Europe only)
Rigging (optional)	Aircraft pan fittings or $\frac{3}{8}$ "-16 nut plates
Physical Dimensions	14" W x 14" H x 22 $\frac{1}{2}$ " D
Weight	67 lbs. (30.4 kg)

M-1A Control Electronics Unit

Input Type	Balanced (active), 47K ohms
Output Type	Active push-pull, will drive 600 ohms
Maximum Input/Output Level	
Balanced	+26 dBu
Unbalanced	+20 dBu
Hum and Noise ³	<-90 dBV
Dynamic Range	120 dB
Sense Inputs	10k ohms true differential, opto-isolated
Electronic Crossover Frequency	1600 Hz
Low-Frequency Delay Type	Active all-pass
Driver Protection Circuitry	
Low Frequency	RMS limiter
High Frequency	RMS limiter
	VHF Peak limiter
Indicators	
Sense, Hi and Lo	Green LEDs
Limit, Hi, Lo, and VHF	Red LEDs
Safe	Green LEDs
Power Supply, Positive and Negative	Green LEDs
Controls	
Front Panel	Input level control, AC on/off switch
Preset Panel	VHF control, Lo Cut switch, Safe switch, VHF switch
Connectors	
Balanced Inputs/Outputs	3-pin XLR (A-3), RTS $\frac{1}{4}$ " phone jacks
Subwoofer Circuit Input	Unbalanced, $\frac{1}{4}$ " phone jack (inserts Lo Cut, disables Level control)
Sense Inputs	Banana jacks
Power	120/240V AC, 50/60 Hz (internally switchable)
Physical Dimensions	19" W x 1 $\frac{3}{4}$ " H x 7 $\frac{3}{4}$ " D Standard rack mount
Weight	8 lbs. (3.6 kg)

Note 1:
Measured 1 meter on-axis, half-space conditions, pink noise input, in third-octave bands.

Note 2:
Loudspeaker driven with weighted noise.

Note 3:
"A"- weighted, unbalanced.

The M-1A Control Electronics Unit



The UM-1C UltraMonitor operates as a system with the M-1A Control Electronics Unit (one per channel). Optimized for the UM-1C and UPA-1C loudspeakers and pre-aligned at the factory, the M-1A contains frequency response and phase response alignment circuitry, and Meyer Sound's exclusive SpeakerSense™ driver protection circuitry, incorporating both peak and RMS signal limiting.

A single-channel device operating at line level, the M-1A is the final component in the signal chain before the amplifier.

SpeakerSense driver protection circuitry protects the UM-1C loudspeaker components from damage due to overheating under high power conditions. This unique circuit continuously monitors the power applied to the UM-1C drivers, and individually limits the high-frequency and low-frequency outputs when the safe operating limits of the drivers are exceeded. Until the onset of overload, the SpeakerSense circuitry has no effect on the signal.

Also provided is a switch-selectable Safeguard function, which widens the safety margin of the system and is intended to be used when extended periods of overload are anticipated. The Safeguard switch and other setup controls are located behind a cover plate on the M-1A front panel, providing a means of securing the system installer's presets.

To enhance the effectiveness of the UltraMonitor in stage monitoring applications, the M-1A incorporates sliding filters which band-limit the system response under full-power conditions. This has the effect of discriminating for vocal information in the signal to increase clarity, and is particularly useful when onstage levels are high and leakage becomes a problem. For this reason, it is recommended that subwoofers be used with the system if it must pass the full audio frequency range at all times (as, for example, in keyboard or drum monitors). The preferred choice of subwoofer for the UltraMonitor is the Meyer Sound USW-1.



Architectural and Engineering Specifications UM-1C/M-1A

M E Y E R S O U N D

The compact speaker system shall be of the two-way type, with a 12" low-frequency loudspeaker front-mounted in a ducted bass-reflex hardwood plywood enclosure, a compression driver mounted on a high-frequency horn which has a 1.4" throat, and a separate Control Electronics Unit.

The Control Electronics Unit shall contain a power supply capable of operating from a 120/240V AC, 50/60 Hz line, electronic crossover circuitry, electronic delay for the phase alignment of the low-frequency speaker, low- and high-frequency protection filters which automatically activate under high power conditions, RMS limiters which protect the speakers from overheating, equalization circuitry, active balanced input, and indicator LEDs for power and limiters. Total harmonic distortion shall be less than .1%. "A"-weighted noise level shall be at least 110dB below maximum rated output of +26 dBu.

The speaker system, its companion Control Electronics Unit, and a power amplifier rated at 250 watts/channel into 8 ohms shall meet the following performance criteria: frequency response, 70 Hz to 18 kHz plus or minus 4 dB measured with 1/3 octave pink noise at 1 meter on axis; output of 125 dB SPL one meter on axis with peaks of 135dB SPL when driven with "A"-weighted noise. Total mid-band harmonic distortion shall be less than 1% at 110 dB SPL and 3% at 120 dB SPL one meter on axis. High frequency distribution pattern, 45 degrees symmetrical.

Speaker enclosure dimensions are 14" W x 14" H x 22½" D, weight 67 lbs (30.4 kg).

Control Electronics Unit dimensions are 19" W x 1¾" H x 7¾" D, weight 8 lbs (3.6 kg).

The speaker system shall be the Meyer Sound UM-1C.

The Control Electronics Unit shall be the Meyer Sound M-1A.

Meyer Sound Laboratories has devoted itself to designing, manufacturing and refining components that deliver superb sonic reproduction. Every part of every component is designed and built to exacting specifications and undergoes rigorous, comprehensive testing in the laboratories.

Research remains an integral, driving force behind all production. Meyer strives for sound quality that is predictable and neutral over an extended lifetime and across an extended range.

Physical Dimensions

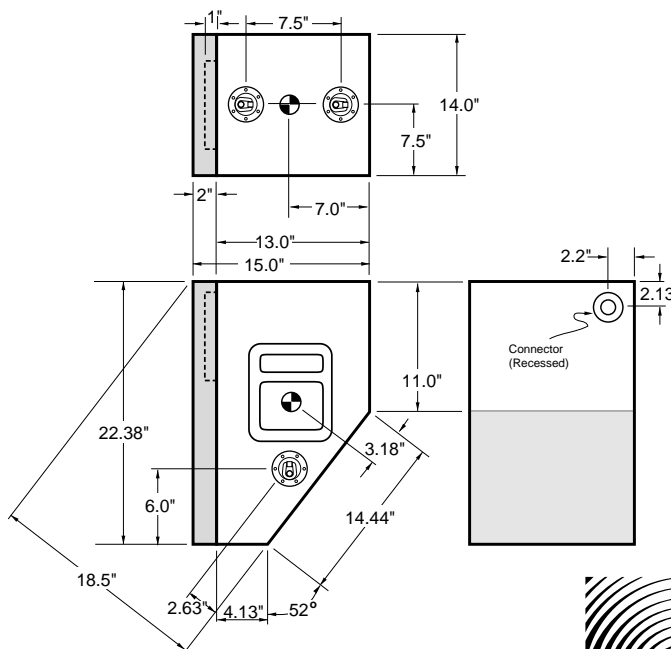

Sound engineering for the art and science of sound.



Meyer Sound Laboratories, Inc.
2832 San Pablo Avenue
Berkeley, CA 94702
(510) 486-1166
FAX (510) 486-8356

Free Manuals Download Website

<http://myh66.com>

<http://usermanuals.us>

<http://www.somanuals.com>

<http://www.4manuals.cc>

<http://www.manual-lib.com>

<http://www.404manual.com>

<http://www.luxmanual.com>

<http://aubethermostatmanual.com>

Golf course search by state

<http://golfingnear.com>

Email search by domain

<http://emailbydomain.com>

Auto manuals search

<http://auto.somanuals.com>

TV manuals search

<http://tv.somanuals.com>