

**Free-Standing
EPA Certified
Wood-Burning Stoves**

**Retain These Instructions
For Future Reference**

P/N 775,214M, Rev. B, 09/2007



Striker™ S160



Striker SA160

**Wood Stoves
Model Striker™ S160**

A French manual is available upon request. Order P/N 775,214CF.

Ce manuel d'installation est disponible en francais, simplement en faire la demande. Numéro de la pièce 775,214CF.

These appliances must be properly installed and operated in order to prevent the possibility of a house fire. Please read this entire installation and operation manual before installing and using your wood stove. Failure to follow these instructions could result in property damage, bodily injury or even death. Contact your local building or fire officials to obtain a permit and information on any installation requirements and inspection requirements in your area.

**NATIONAL
FIREPLACE
INSTITUTE**
NFI
CERTIFIED

www.nficertified.org

We recommend that our woodburning hearth products be installed and serviced by professionals who are certified in the U.S. by the National Fireplace Institute® (NFI) as NFI Woodburning Specialists or who are certified in Canada by Wood Energy Technical Training (WETT).

**Wood Energy
Technical Training**
www.wettinc.ca

Tested & Listed By **O-T-L** Beaverton Oregon USA
C-T-I-US
OMNI-Test Laboratories, Inc.
Report # 050-S-03b-2

	<p>⚠ WARNINGS</p> <ul style="list-style-type: none"> Hot! Do not touch! The glass and surfaces of this appliance will be hot during operation and will retain heat for a while after shutting off the appliance. Severe burns may result. Carefully supervise children in the same room as appliance.

TESTING INFORMATION

This manual describes the installation and operation of the Striker™ S160 non-catalytic wood heaters. These heaters meet the U.S. Environmental Protection Agency's emissions limits for wood heaters sold on or after July 1, 1990. This heater has been developed, tested, and constructed in accordance with the requirements of UL 1482, ULC S627-and HUD standards and is listed by OMNI Test Laboratories, Beaverton, OR. It has been approved for residential, mobile home, and alcove installations.

GENERAL SAFETY PRECAUTIONS

1. When this room heater is not properly installed, a house fire may result. To reduce the risk of fire, follow the installation instructions. Contact local building or fire officials about restrictions and installation inspection requirements in your area.
2. Wear gloves during installation to avoid injury from sharp edges on the stove and/or its parts.
3. This unit is designed and engineered to burn only dry, well-seasoned wood. Burning wet wood will greatly reduce the Stove's efficiency, produce excessive amounts of smoke, and can cause dangerous chimney fires due to creosote build-up.
4. Before opening the door, the **draft control must be fully open to avoid possible combustion flash** (ignition of hot volatile gases as the door is opened).
5. Do not use gasoline, gasoline-type lantern fuel, kerosene, charcoal lighter fluid, or similar liquids to start or "freshen up" a fire in this stove. Keep all flammable liquids and combustible materials 36" from any point of the stove when it is in use.
6. While burning, fuel utilizes oxygen from the air in the room. Be sure to allow an adequate amount of fresh air into the room where the stove is burning.
7. The outside surface of the stove will be hot while burning properly and can set items like clothing and curtains on fire. Keep furnishings and other combustible materials away from the stove. Using the heat from the stove to dry wet clothing can be hazardous if clothes are placed too near the surface of the stove.
8. Do not allow children to play near the stove without close supervision. Do not touch the stove while it is burning. Use extreme caution while the unit is in use. Surface temperatures become dangerously hot and can cause serious burns.
9. Do not allow anyone to operate the stove who is not familiar with the operating instructions.
10. Attempts to achieve heat output rates that exceed stove design specifications can result in permanent damage to the stove. Never leave your stove unattended on high burn rates. This may cause overfiring. Overfiring the stove may cause a house fire. **If the stove glows, you are overfiring.**
11. Use smoke detectors near your stove as well as in sleeping areas. Keep a water hose or hand-operated fire extinguisher close for safety.
12. Inspect your chimney at least once a month during the burning season to check for soot and creosote accumulations. Any accumulations over 1/4" thick should be removed by a professional chimney sweep. Do not attempt to burn out heavy creosote accumulations with a hot fire. If large accumulations are occurring, review your burning procedures.

NOTE: DIAGRAMS & ILLUSTRATIONS ARE NOT TO SCALE.

TABLE OF CONTENTS

TESTING INFORMATION	2
GENERAL SAFETY PRECAUTIONS	2
NEGATIVE PRESSURE WARNING	4
CREOSOTE	4
ASH DISPOSAL	4
DRAFTING	4
FUEL	5
BREAK-IN PERIOD	5
PAINT CURING	5
CLEARANCES TO COMBUSTIBLES	6
INSTALLATION	7
MOBILE HOME INSTALLATIONS	7
LEG AND HEATSHIELD INSTALLATION	7
OUTSIDE AIR KIT INSTALLATION	8
STOVE INSTALLATION	9
PEDESTAL INSTALLATION	10
POST INSTALLATION CHECKS	11
BRICK INSTALLATION	11
OPTIONAL BLOWER INSTALLATION	13
OPERATING HINTS	13
STARTING AND MAINTAINING A FIRE	14
CLEAN GLASS	15
OPERATING TECHNIQUES AND HINTS	15
GETTING THE MOST OUT OF YOUR STOVE	15
MAXIMIZING YOUR STOVE'S OVERALL EFFICIENCY	16
ACHIEVING CLEAN, LONG BURNS	16
MAINTENANCE	17
TROUBLESHOOTING	18
DO'S AND DON'TS	19

13. If a creosote fire should develop, the fire department should be called immediately, and then attempts should be made to control the fire until assistance arrives. If a “runaway” fire should develop causing over-heating of the stove, the door and draft regulators should be closed immediately. The fire should die down once deprived of oxygen. After a severe chimney fire, the complete chimney system should be checked before further use.
14. Do not operate with a grate or with an elevated fire. Always build the fire on the surface of the firebrick.
15. Please read this entire manual before you install and use your new room heater. Failure to follow instructions may result in property damage, bodily injury, or even death.

DRAFTING

Your wood stove is dependent upon a properly functioning chimney for optimum performance. It is a high efficiency appliance that loses much less heat up the chimney than older appliances and fireplaces. For this reason it is important to match the stove to the chimney. The chimney has two functions: 1) It draws combustion air into the appliance (without air, no fuel will burn) and 2) It exhausts combustion by-products. Your new Country™ Collection stove is what is known as a “natural draft” appliance. The appliance depends solely on the natural draft of the chimney system to draw combustion air into the unit. Draft is the force that moves air from the appliance up into the chimney. The amount of draft in your chimney depends on the length of the chimney, local geography, nearby obstructions, and other factors. Too much draft may cause excessive temperatures in the appliance. **Slow or inadequate draft equals poor combustion and possible smoking problems.** The two main culprits of poor chimney draft are: 1) A chimney too large for your appliance and 2) A chimney with not enough height to produce adequate draft for your particular stove model. Your Lennox Hearth Products dealer will be able to advise you on matching a proper system for your new stove. Inadequate draft will cause the appliance to leak smoke into the room through the stove and the chimney connector joints. An uncontrollable burn or a glowing red stove or chimney part indicates excessive draft. Also see Troubleshooting on page 18.

NEGATIVE PRESSURE WARNING

This appliance is not designed to be operated in a negative pressure. Very airtight homes with large kitchen exhaust fans, or homes with furnace cold air returns located in close proximity to the wood stove or fireplace insert may create negative pressure in the same room as the heating appliance. This can create dangerous back drafting of the stove and chimney joints, drawing combustion by-products into the home. Be sure your home has adequate makeup air to eliminate negative pressures caused by the above-mentioned sources. Outside air connected to the appliance probably will not resolve such a problem as the stove or fireplace insert is not the source of negative pressure. Lennox Hearth Products accepts no liability for damages resulting from negative pressures described above.

CREOSOTE

Creosote---Formation and Need for Removal---When wood is burned slowly, it produces tar and other organic vapors, which combine with expelled moisture to form creosote. The creosote vapors condense in the relatively cool chimney flue of a slow-burning fire. As a result, creosote residue accumulates on the flue lining. When ignited, this creosote makes an extremely hot fire. The chimney and chimney connector should be inspected at least once every two months during the heating season to determine if a creosote build-up has occurred. If creosote has accumulated, it should be removed to reduce the risk of a chimney fire.

ASH DISPOSAL

Ashes should be scooped out of a cool stove with a small metal shovel. Ashes should be placed in a metal container with a tight fitting lid. The closed container of ashes should be placed on a non-combustible floor or on the ground, well away from all combustible materials, pending final disposal. If the ashes are disposed of by burial in soil or otherwise locally dispersed, they should be retained in the closed container until all the cinders have thoroughly cooled. Ashes can ignite up to 72 hours after removal from the stove.

FUEL

This unit is designed and engineered to burn, dry, well-seasoned wood only. Dry, seasoned wood is that which has been cut, split, and allowed to dry under a covered area where air is free to flow and circulate under and around the wood (not under a tarp or plastic). Make sure wood is not stacked directly on the ground, it may absorb moisture from the ground. It should be allowed to dry in these conditions for a minimum of six months, preferably one year or more.

IT MUST BE UNDERSTOOD THAT WOOD CANNOT BE LEFT IN ANY KIND OF WET OR DAMP AREA OR IT WILL NEVER BECOME COMPLETELY SEASONED. Your stove will not operate at the level that it is meant to unless you use seasoned, dry wood. Do not burn driftwood or wood that has been in salt water, doing so will void your warranty. Do not burn treated wood, coal, garbage, cardboard, solvents, or colored paper. Burning treated wood, garbage, solvents, or colored paper may result in the release of toxic fumes. This type of burning will also void your warranty.

BREAK-IN PERIOD

If your stove has a Gold or Nickel-Plated Door, be sure to clean it with Windex brand glass cleaner and a very soft cloth to remove any fingerprints and residues prior to the first fire and before any fire if the gold has been handled or soiled. Do not close the door tightly during the "Break-in Period." Also, open the door frequently (every 5-10 minutes) to keep the gasket from adhering to the curing paint. Ventilate the house well during these first firings as the paint gives off carbon dioxide and unpleasant odors. It is recommended that persons sensitive to an imbalance in the indoor air quality avoid the stove during the curing process.

Please be patient with the heat output of your stove for the first few weeks. The steel will go through a curing process that eliminates moisture, which is deep in the steel and firebrick. This moisture will reduce initial heat output of your stove and may make it difficult to start. After you have broken in the paint on the stove it will be necessary to build hot fires to thoroughly remove the moisture from the appliance. Running the stove with the draft fully open for 1 to 1-1/2 hours after starting and adding generous amounts of fuel during the first week or two should complete the curing process. We recommend the use of a thermometer attached to the stovetop or chimney. Temperatures on the connector pipe should run in the 250-600 degree range. **(DO NOT OVERFIRE THE STOVE DURING THIS PROCESS. IF THE STOVE OR CHIMNEY BECOMES RED, REDUCE THE AMOUNT OF AIR ENTERING THE STOVE IMMEDIATELY).**

PAINT CURING

Your new Striker™ S160 is painted with Forest High Temperature Paint that cures during the first few firings. We recommend that you put your stove through a regimen of three burns. The first two should last for 20 minutes each at 250 degrees (the stove should be allowed to cool completely between each burn). The third should be a burn of at least 450 degrees F. for 45-60 minutes. The paint will become soft, gummy, and emit non-toxic smoke during these burns. After the stove cools down for the third time, the paint will harden. **DO NOT BUILD A LARGE ROARING FIRE UNTIL THIS CURING EFFECT IS COMPLETE OR YOU MAY DAMAGE THE FINISH OF YOUR STOVE.** Spray can touch-ups should be done only with Forest brand paint, available from all Lennox Hearth Products dealers.

CLEARANCES TO COMBUSTIBLES

WARNING: BE ABSOLUTELY SURE THE DISTANCE BETWEEN THE HEATER AND THE SURFACE OF ANY COMBUSTIBLE CONSTRUCTION IS NOT LESS THAN SHOWN.

Floor Protection

USA - The floor in front and under the heater must be protected with a minimum of 3/8" thick noncombustible material. The covering must extend 16" in front of the door opening of the heater and 8" to either side of the door opening and 5-1/2" to the rear or to the wall, whichever is smaller. In all installations a 16" minimum hearth extension (in front of the stove) is required as measured from the door opening of the unit.

Canada - The floor in front and under the heater must be protected with a minimum of 3/8" thick noncombustible material. The covering must extend 457 mm in front of the door opening of the heater and 200mm to either side of the stove body and 200 mm to the rear or to the wall, whichever is smaller. In all installations a 457mm minimum hearth extension (in front of the stove) is required as measured from the door opening of the unit.

Reduced Clearances

Clearances to combustible surfaces can be reduced with the use of listed double wall connector pipe. See the clearances with double wall pipe on the following page.

Alcove Clearances

Single Wall Pipe - Minimum 48"(1219mm) width, maximum 48" (1219mm) depth. Minimum ceiling height is 72" (1829m).

Double Wall Pipe - Minimum 44"(1117mm) width, maximum 48" (1219mm) depth. Minimum ceiling height is 72" (1829m).

Mobile Home Installations

All mobile home installations require an outside air kit (part # 71111 or 71112). The stove must be bolted to the floor and grounded to the chassis of the mobile home.

WARNING: DO NOT INSTALL IN SLEEPING ROOM OF A MOBILE HOME.

CAUTION: THE STRUCTURAL INTEGRITY OF THE MOBILE HOME FLOOR, WALL, AND CEILING/ROOF MUST BE MAINTAINED.

Approved Chimney* - Your stove is approved for use with Class A, UL 103HT Chimney and double wall connector pipe from **Security™ Chimneys**.

Clearances to connector pipe shall be measured from the flue collar of the stove.

Chimney & Connector

Minimum 6" diameter, minimum 24 MSG black steel connector pipe with listed factory-built chimney suitable for use with solid fuels or masonry chimney. Horizontal connection not tested, refer to local building codes for installation. Restrictions apply! Read instructions before installing.

Clearance dimensions are to 6" (152mm) flue collar. If a single wall connector pipe with shield is used, a 1 inch air space is needed between pipe and shield. Shield attaches to rear of stove pipe and must run from stove top to ceiling. Pipe shield shall be UL listed.

Residential chimney systems must be from the same brands as listed for mobile homes but connector pipe may be double wall, single wall or single wall with shield as listed above.

Connector pipe and chimney must be of the same brand.

Components Required For Installation

Legs AND Bottom Heat Shield or Pedestal Base.

If optional blower is NOT used, Rear Heat Shield Block Off Plate shall be installed.

* Other approved chimney brands are Projet, Jakes Evans/GSW, Dura-vent, Metal Fab, Ameri-Tec, Metalbestos and Industrial Chimney (ICC).

INSTALLATION CLEARANCES - REFER TO DIAGRAMS A, B & C

PIPE	INSTALLATION	A	B (1)	C	D (1)	E†	F (1,4)	G (4)
6" Single Wall	Residential or Alcove	USA-16" CAN-483mm	14" 356mm	USA-21" CAN-610mm	12-1/2" 318mm	8" 200mm	9-3/4" 248mm	USA-18" CAN-533mm
6" Single w/ Pipe Shield	Residential or Alcove	USA-10" CAN-330mm	8" 200mm	USA-18" CAN-533mm	9-1/2" 241mm	8" 200mm	5-1/2" 140mm	USA-13-1/2" CAN-419mm
6" Double Wall	Residential or Alcove or Mobile Home*	USA-10" CAN-330mm	8" 200mm	USA-18" CAN-533mm	9-1/2" 241mm	8" 200mm	5-1/2" 140mm	USA-13-1/2" CAN-419mm

PIPE	INSTALLATION	H (2)	I (6)	J (2)	K	L (5)	M
Single Wall	Residential or Alcove	USA-33-3/4" CAN-1111mm	USA-47-3/4" CAN-1340mm	USA-33-1/2" CAN-1003mm	USA-16" CAN-450mm	USA 0" CAN-200mm	84" 2134mm
Single w/ Pipe Shield	Residential or Alcove	USA-33-3/4" CAN-1111mm	USA-41-3/4" CAN-1188mm	USA-33-1/2" CAN-1003mm	USA-16" CAN-450mm	USA 0" CAN-200mm	84" 2134mm
Double Wall Air-Cooled	Residential or Alcove or Mobile Home*	USA-33-3/4" CAN-1111mm	USA-41-3/4" CAN-1188mm	USA-33-1/2" CAN-1003mm	USA-16" CAN-450mm	USA 0" CAN-200mm	72" 1829mm

PIPE	INSTALLATION	N ❶	P ❶	T (6)
Single Wall	Residential or Alcove	30" 762mm	36" 914mm	USA-58-1/2" CAN-1645mm
Single w/ Pipe Shield	Residential or Alcove	30" 762mm	36" 914mm	USA-52" CAN-1686mm
Double Wall Air-Cooled	Residential or Alcove or Mobile Home*	30" 762mm	36" 914mm	USA-52" CAN-1686mm

† USA=8" (200mm) from door opening, Canada=8" (200mm) from sides and back of unit

❶ Dimensions to Stove Body

* Mobile Home - USA only

Diagram A: Top View-Parallel Installation

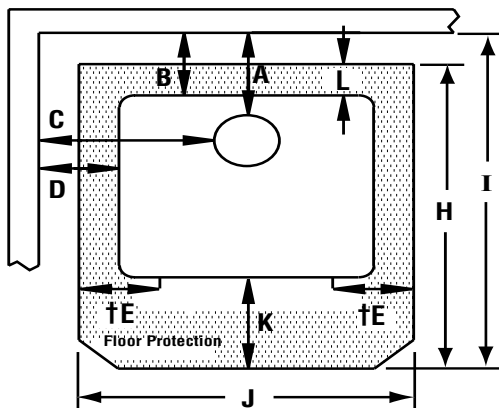
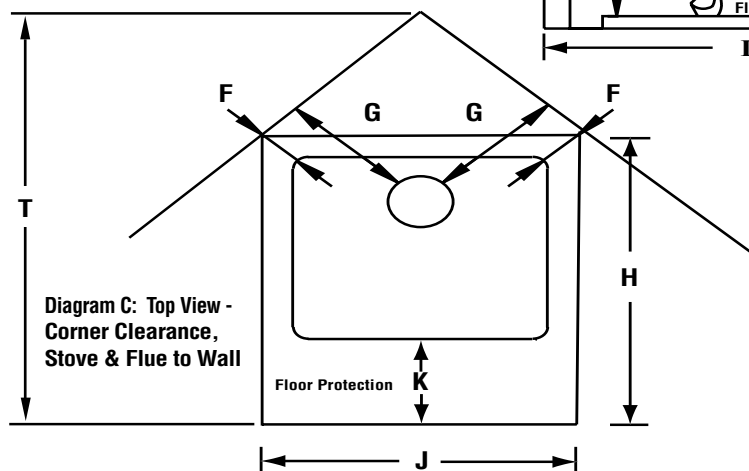
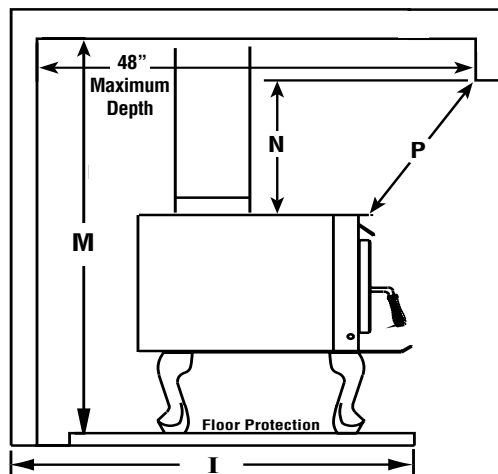

Diagram B: Side View-Alcove & Parallel Installation



Footnotes:

- 1- These dimensions to the stove body are for reference only. Actual distances should be measured from the stove's flue collar.
- 2- Minimum noncombustible hearth pad dimensions.
- 3- Shield shall be attached to the rear of the stove pipe with a 1" air space and must run from the top of the stove to the ceiling.
- 4- Not applicable to alcove installations.
- 5- In corner applications, when installed at minimum back wall clearances, the required floor protection is dimensioned off the back plane of the stove, therefore the floor protection required off the back corners (at a 45 degree angle) only needs to extend to the wall. This situation will only occur in CANADA installations.
- 6- Reference dimension only, to assist in planning the installation.

Clearances to connector pipe shall be measured from the flue collar of the stove.

LEG AND HEATSHIELD INSTALLATION

Note: The threaded rods used to bolt the legs to the stove are packaged with the heatshield, as a heatshield is required when a stove is installed on legs.

Residential and Mobile Homes

(Bolting down and grounding of stove are required only in mobile homes).

Open all cartons, if any, and remove the contents upon receipt and check for any damaged or missing parts. If there is hidden damage, notify your freight company or Lennox Hearth Products dealer immediately.

Leg Installation

1. Carefully place stove on its back. Be careful not to scratch the stove, use a piece of cardboard or carpet to protect the back of the stove.
2. Mount all four legs as shown in Figure 1 below.
3. First, screw the threaded rods into the holes at the four corners on the bottom of the stove. Screw the threaded rods into the firebox three full rotations or $3/16$ to $1/4$ " (if the rear rods are screwed in too far they will lift the bricks off the bottom of the stove). Use a washer and nut to secure the leg. Be sure the legs are mounted squarely on the firebox bottom. Tighten nuts securely.
4. Use the two bolts and washers provided with the heatshield kit to mount the heatshield as shown in Figure 2 below.
5. Do not over tighten the heatshield mounting bolts as it may bend the heatshield.

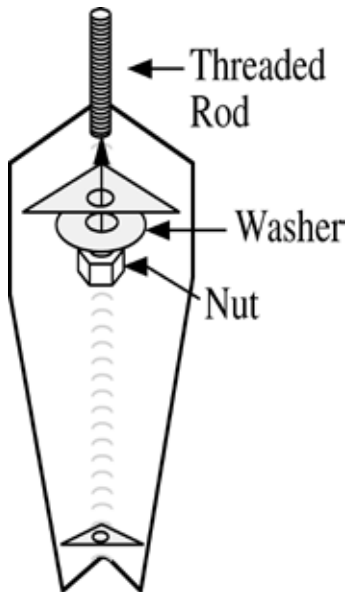

Figure 1

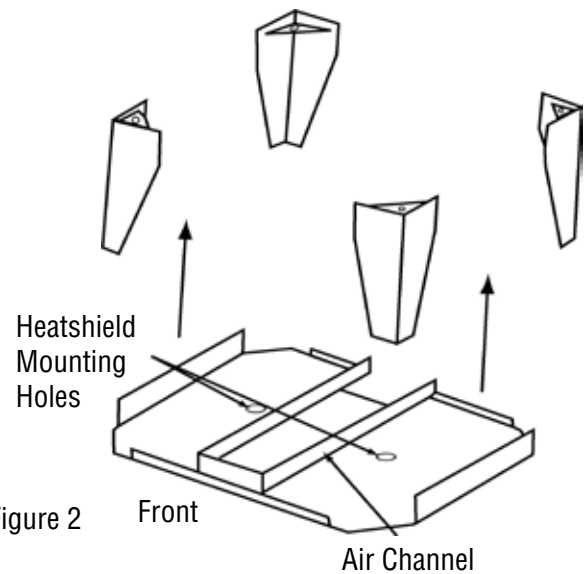

Figure 2

OUTSIDE AIR KIT INSTALLATION

To install the "Outside Air Kit," position the clip so that the nut is directly above the hole punched in the back of the heatshield (See Figure 3). Install the outside air adapter box on the stove by sliding it into the air channel located between the bottom heatshield and the stove bottom until the oblong ring is approximately $1/4$ " from the rear edge of the lower heatshield. Make sure the ring is facing down. Thread the $1/4$ " bolt up through the nut in the clip until snug against the adapter box.

Expanded View of Clip



Line up the hole in the clip with the hole in the rear center of the bottom heatshield

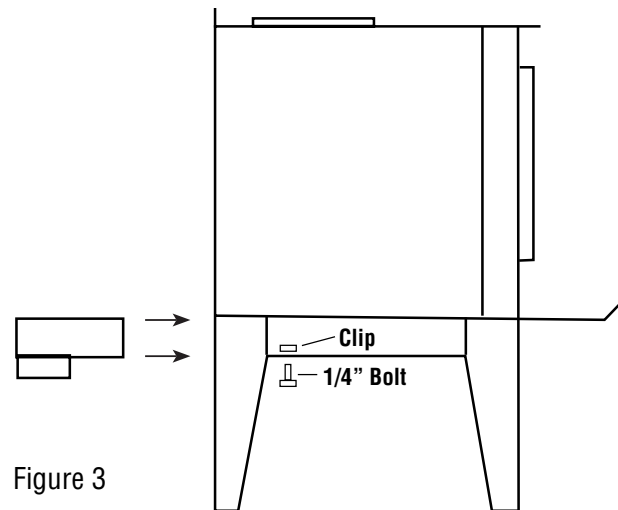

Figure 3

To locate the hole in the hearth for outside air, mark a 4" circle on the hearth. The circle's center should be $2-3/4$ " directly back from the center of the flue outlet and $5/8$ " to the left side.

STOVE INSTALLATION

1. If not previously installed, install floor protection and move the heater into the desired location.
2. Position the stove on your floor protection in the exact location where it is to be located, making sure all minimum clearances are met.
3. If you are installing outside air on your stove, mark a 4" circle on the floor protection just below the oblong ring. When cut out, this hole will accommodate the flexible outside air tube.
4. If the stove is to be fastened to the floor, locate the hold down brackets inside the leg box and mark the floor protection below the holes in the brackets.
5. If you are installing outside air on your stove, remove the stove and cut the floor protection and the floor where the 4" air tube circle had been previously drawn. If the stove is to be fastened to the floor, drill 1/2" holes through the floor protection only, at the marks that were for fastening the stove to the floor if so desired. Slip the flexible outside air tube through the hole in the floor, leaving 1" of tube above the floor protector surface, using tape to hold it in place.
6. Place the stove on the floor protection so that the previously cut or drilled holes line up. Attach the stove to the floor with the lag bolts if so desired.
7. If you are installing outside air on your stove place the hose clamp over the flexible air tube and slide the tube up over the 4" ring on the outside air adaptor box and tighten the hose clamp. Push the outside air adaptor forward 1/4" until full contact is made with the lower heatshield. Tighten the 1/4" bolt until the adaptor box is held firmly in place. Use silicone sealant to create a seal between the flexible air tube and your floor protection.
8. If it is necessary to level, secure or ground your stove, use the holes in the bottom of the leg for those applications. To level the stove on Olympic cast legs, locate the front leg that is not touching the hearth pad. Insert the allen head screw through the slotted washer (supplied with the legs) and into the threaded hole in the bottom of the leg. See the drawing to the right. Push the slotted washer down until it touches the hearth pad and then tighten the screw into the leg. Should any other leg not be resting on the hearth pad, install a washer and screw in that leg as well.
9. Install bricks and baffle as per instructions on page 11. It is highly recommended that the baffle be assembled before the chimney is installed so that the insulating fiber blankets can be adjusted into place through the flue collar.
10. If installed into a mobile home, the stove shall be grounded to the mobile home chassis with a #8 AGW copper wire or equivalent.
11. For residential installations, install the first section of stove pipe with the crimped end going down inside the flue collar on the heater. Continue with your stove pipe, installing each section-crimped end down. Make the final connection to your chimney. Your dealer carries the necessary pipe and fittings to connect to the various listed factory-built chimneys. **YOUR CHIMNEY INSTALLATION MUST COMPLY WITH LOCAL BUILDING AND FIRE CODES.**
12. Be sure to fasten each stove pipe connection with at least 3 sheet metal screws.
13. Install chimney as per manufacturer's instructions. Some brands of pipe may require removal of the spacer ring in the flue collar.
14. All horizontal runs of pipe should be as short as possible and are required by NFPA No. 211 to have an upward pitch or rise in the same direction the smoke travels of no less than 1/4" to the linear foot. The connector pipe must meet minimum clearances in any direction to walls or other combustible materials. It must attach to a listed double wall metal chimney at least 6" in diameter or to a masonry chimney with a flue passage of at least 48 square inches.
15. It is required that a chimney connector pipe not extend further than the inner wall of the flue when it is connected to a masonry chimney, and that it either be cemented to the masonry or be installed without cement in a thimble connected to the masonry wall. When the connector is inserted into a thimble, the joint must be tight enough so that it will not be dislodged in normal use.
Install connector at no less than the minimum clearances from the ceiling when using a 90-degree elbow to pass through combustible constructions.
16. Chimney connector pipes should never pass through a floor, ceiling, fire wall, partition, or combustible construction of any type unless certain precautions are taken. The best method is to use a listed thimble and a listed chimney in accordance with the manufactures directions. NFPA No. 211 gives approved methods for passing a flue pipe through combustible constructions.



PEDESTAL INSTALLATION

(For ash drawer pedestal see instructions included with pedestal).

Residential and Mobile Homes

(Bolting down and grounding are required only in mobile homes).

Caution: Wear gloves during installation in case of sharp edges on the stove.

1. Remove the heater from the carton, if packaged, upon receipt and check for any damaged or missing parts.
2. Carefully put the stove on pedestal with the open end of the pedestal facing the rear. **DO NOT LEAVE THE STOVE UNATTENDED UNTIL IT IS BOLTED SECURELY TO THE PEDESTAL.**
3. Line up the holes in the brackets on the pedestal with the threaded holes in the bottom of the stove. Use the two 1/2" long bolts and 3/8" standard washers to bolt the stove to the pedestal. Be sure to see that the stove is mounted squarely on the pedestal before tightening the two bolts securely.
4. When installing a pedestal on this stove you **MUST** plug the four leg mounting bolt holes, located on the bottom of the stove in the four corners, with the bolts that were used to mount the shipping legs. **The two rear bolts should not be installed more than two full rotations to prevent lifting the bricks off the bottom of the stove. FAILURE TO INSTALL THESE FOUR BOLTS PROPERLY WILL RESULT IN REDUCED CONTROL OF THE STOVE'S COMBUSTION SYSTEM!**
5. If required, install the Outside Air Kit (71112) as per the following instructions. To locate the hole in the hearth for outside air mark and cut a 4" hole in the hearth. The hole's center should be 3" directly forward from the center of the flue outlet or locate as per the instructions below.
6. Position the stove on your floor protection in the exact location where it is to be located, making sure all minimum clearances are met. Mark the floor protection where the pedestal will be located, then remove the stove.

7. Make four 1-1/2" cuts in one end of the corrugated tube and fold the flaps back. Cut a 4' hole through the floor protection and the floor, and insert the corrugated tube into the hole. Cover it with the supplied screen and fasten it to the floor protector.
8. Locate the 11-1/2"x 14" metal plate and paint to match the stove if necessary. Position this piece so that the 14" dimension evenly overlaps the lips on the back of the pedestal (see drawing above). Attach this plate to the back of the pedestal with the self-tapping screws supplied.
9. If the stove is to be fastened to the floor, attach the stove with the supplied lag bolts, through the pedestal base on opposite sides, attaching them into the floor beneath the floor protection. Seal any irregularities with silicone sealer.

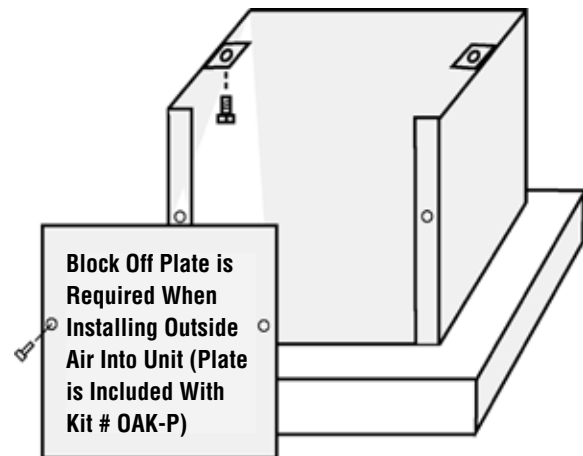

10. If installed in a mobile home, the heater shall be grounded to the chassis with a #8 AGW copper wire or equivalent.
11. Install bricks as per instructions on pages 11 and 12. It is highly recommended that the baffle be assembled before the chimney is installed so that the ceramic fiber blankets can be adjusted into place from the flue outlet.
12. Install chimney as per manufacturer's instructions.

POST INSTALLATION CHECKS

1. Check that all chimney pipe joints are securely fastened.
2. Check that the heater is securely fastened to the floor (if applicable).
3. Make sure the intake vent has clear access to outside air (if applicable).
4. Make sure the outside air vent has been sealed properly to keep rodents out (if applicable).
5. Be sure all roof flashings are watertight.
6. Be sure the stove is properly grounded (if applicable).

FOR YOUR OWN PROTECTION AND INSURANCE PURPOSES, HAVE YOUR CHIMNEY AND CONNECTOR PIPE INSTALLATION INSPECTED BY YOUR LOCAL BUILDING CODE AUTHORITY OR FIRE MARSHAL BEFORE STARTING A FIRE IN YOUR STOVE. NOTIFY YOUR INSURANCE COMPANY.

BRICK INSTALLATION

CAUTION: Wear gloves during brick installation in case of sharp edges inside the stove.

Note: Installation of the baffle bricks and insulating blanket is easier when you can still access the flue outlet, (before connecting the flue pipe). **Be sure the insulating blanket is placed flat on the bricks so as not to block the flue.** Use a ruler or a piece of kindling to reach over the blanket to be sure it is completely flat on top of the baffle bricks.

Measure bricks before installing, as per list of dimensions on next page, to be sure the correct bricks are installed in the correct location.

1. Install bricks #1-18 in the numbered sequence shown in Figure 6 on the next page.
2. Next, install bricks #19 & 20 into the rear stainless steel baffle support (see Figures. 7 & 8 on the next page).

3. Next, install baffle bricks #21-24 by sliding the back of each brick over the center tube and support until the front of the brick clears the front tube and support. Then lift the front of the brick above the front support and tube and slide it forward as far as it can go (very important), it will hit the front of the stainless support when it is fully forward. The rear of the bricks sit on top of bricks #19-20 (Figures. 7 & 8).

4. Carefully slip the ceramic blanket up over the front of the front stainless support and bricks #21-24. Grasp the edge of the blanket and slide it back until the front of the blanket is flush to the front of bricks #21-24 (Figure 7). Shake the blanket gently from side to side to get it to lay flat. Be sure the ceramic blanket is directly on top of the baffle bricks and that it does not hang out past the front of the baffle as shown in Figure 7, also see note above.

Figure 6

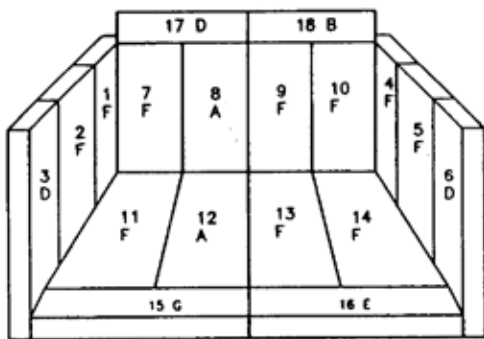

Brick Sizes

- A = 4-1/4" x 9"
- B = 2-1/4" x 8-7/8"
- C = 3-1/2" x 9"
- D = 2-1/4" x 9"
- E = 1-1/2" x 8-7/8"
- F = Full Brick (4-1/2" x 9")
- G = 1-1/2" x 9"
- H = 3-1/2" x 8-7/8"

Figure 7

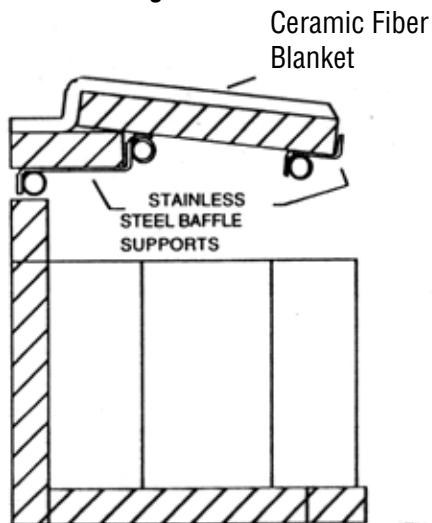
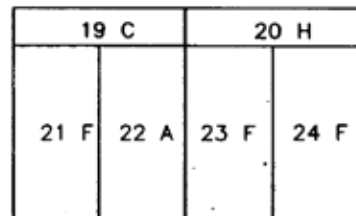

Figure 8

Baffle Bricks Top View



NOTE: DIAGRAMS & ILLUSTRATIONS ARE NOT TO SCALE.

OPTIONAL BLOWER INSTALLATION

A blower, part# 71000, can be installed on the stove to improve hot air distribution throughout the room. To install the blower:

1. Remove all the contents from the blower box. Included with the blower should be a blower speed control.
2. Remove the screws in the round knock-out plate on the back of the stove. Bend the knock-out plate back and forth until it can be removed.
3. Mount the blower as shown below. Make sure the cord is at the bottom when mounted and that it does not touch the stove anywhere. Remove the four screws from the back of the stove. Use one of the four screws with a washer on it and attach the blower through one of the four mounting legs on the blower housing. Check to make sure that the fan blade does not touch the large hole in the rear heatshield. (Spin it to check all directions). Finish attaching the blower with the other three screws. Tighten the screws moderately tight but do not over tighten as you may strip the holes out.

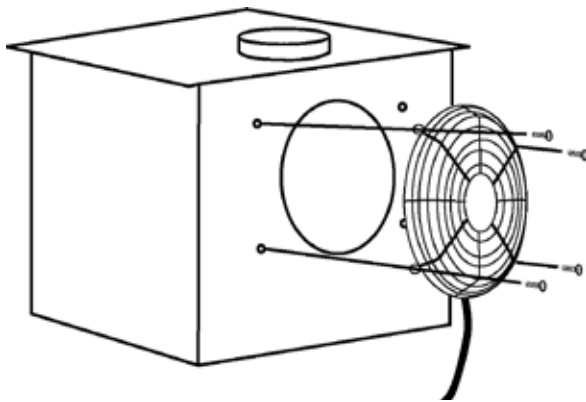

4. Plug in the fan speed control into the nearest outlet, then plug the blower cord into the speed control. Do not route the fan power cord under the stove or allow it to come in contact with any surface of the stove. Read the section Starting and Maintaining a Fire for proper fan operating instructions on page 15.

WARNING: In the event that you remove the blower for any reason, make sure a cover plate available from Lennox Hearth Products is reinstalled before using the heater. Excessive rear wall temperatures will result if the stove is burned without the cover plate.

OPERATING HINTS

1. Burn only dry, well-seasoned wood for maximum heat output. In some states it is illegal to burn wet wood or anything other than clean, dry wood products.
2. Your stove is designed to operate with the door closed! Operate only with the door shut tightly at all times except when loading wood.
3. **DO NOT** hit or move the baffle brick while loading wood. Occasionally check the baffle. Make sure the insulating blanket is always flush with the front of the baffle brick. Loading oversized logs may dislodge the baffle bricks.
4. **CAUTION: THE DRAFT CONTROL MUST BE FULLY OPEN BEFORE OPENING THE DOOR TO AVOID POSSIBLE COMBUSTION FLASH!!** (Ignition of hot volatile gases as the door is opened).
5. Feeding excessive amounts of fuel to the stove should be avoided. It is important to supply it with sufficient draft and fuel to maintain a moderately hot fire. If, during overnight burns, heavy creosote deposits develop inside your stove and on the door, the draft is set too low - review your burning habits!



STARTING AND MAINTAINING A FIRE

Be sure to clean the Nickel or Gold Plated door with Windex brand cleaner and a very soft cloth to remove any fingerprints and residues prior to the first fire.

1. **NEVER USE FLAMMABLE LIQUIDS TO START OR REKINDLE A SOLID FUEL FIRE!!**
2. Fully open the primary draft control by pulling the 1" plastic knob out on the left side (lower front corner) until it stops (away from the stove). This control determines the amount of air entering the stove. Pushing it toward the stove reduces the burn rate in the firebox. For your convenience, the rod on this control is marked with four grooves to assist you in obtaining repeatable burn rates.
3. Place a small amount of crumpled paper in front of the firebox and cover it with a few pieces of kindling.
4. Light the paper and allow sufficient time for the kindling to become fully engulfed in flames. Close the door. Your door may or may not need to be left slightly open during this process, depending on your stove model and chimney draft. Once the kindling is burning well, larger pieces of wood may be added.
5. For best results, use smaller pieces of wood to get stove temperature very high before loading larger wood for sustained burns. If necessary, crack the door to allow ignition of the fuel charge. Now you can add larger pieces of wood and after several minutes of high burn, set the left control for the desired heat output. Check the exhaust in about 15 to 20 minutes. Large amounts of smoke indicate an improper burn setting (either too high or too low). Adjust and recheck in 5 to 10 minutes.
6. After your stove has been thoroughly preheated, your blower can be switched on. When refueling your stove, turn the blower off for the first 30 minutes. On low and medium-low burns run the blower on low. These burn rates would be achieved by operating the stove with the draft rod fully pushed in to up to 3/4" open (out). To do this, turn on the blower at the speed control and rotate the control all the way to the right. On medium-high and high burns you may run the blower on high. These burn rates would be achieved by opening the draft rod further than stated previously. To do this, turn on the blower with the speed control and do not rotate the switch after it clicks on.

NOTE: DIAGRAMS & ILLUSTRATIONS ARE NOT TO SCALE.

CLEAN GLASS

SEE MAINTENANCE ON PAGE 17 FOR GLASS CLEANING TIPS

The operator plays an important part in keeping the glass clean and free of build-ups. The first and most important part the operator plays is making sure to burn only well-seasoned firewood. **Wet wood = Dirty glass.** Keeping your glass door clean is partly accomplished by the air wash system of the stove, which sends clean, fresh air for combustion, over the window before it enters the fire. The high temperatures inside the firebox also keep the glass clean. **No stove door stays perfectly clean.** The following are methods for keeping build-up on your glass to a minimum. When properly installed and operated by a knowledgeable operator, your glass door should require very little maintenance. Do not expect to get extremely long burn times and keep the window perfectly clean. Cool temperatures cause condensation of unburned volatiles on the glass. If your glass gets very dirty during overnight burning, try preheating the stove a little longer before damping it down for an overnight burn. Also, don't damper your stove down as low because **you'll get more heat for your money by burning a little hotter for a slightly shorter time.**

The air wash system will perform at its best at medium burn rates. Some stove models will self clean by burning very hot fires but be sure not to over-fire the stove. **If it glows red it is over-fired.** Over-firing a stove also causes the window to soot up. Extremely hot fires with fresh wood may cause the flow rate to exceed one foot per second, which is as fast as a flame can burn. This is why a candle goes out when you blow on it. Blow on it gently and it burns brightly. Blow on it hard and it goes out. This will cause excessive exhaust emissions and your window to soot up, as the stove is unable to burn the gases emitted from the wood. Try slowing the stove down a little by closing the damper somewhat as it warms up.

Keeping freshly loaded wood away from the window will also help. Load fresh logs in the rear of the firebox. Build-up tends to occur first on the right side of the window. This is caused by the swirling motion of the exhaust gases similar to water running down a drain. Keep fresh logs further back on the right side of the firebox to help prevent this problem.

Understanding how your Country™ Collection stove works should help you keep your glass door very clean, but as stated: **no glass door stays perfectly clean.** We hope this information is helpful in keeping your glass door clean so that you may enjoy many hours viewing your high efficiency stove. For more information, contact your Lennox Hearth Products dealer.

OPERATING TECHNIQUES AND HINTS

Recent developments in wood-burning technology have made wood-burning a cleaner and more convenient way to heat your home. Overall efficiency in a wood-burning appliance is a combination of combustion efficiency and heat transfer efficiency. Whether heating your entire home, or just a room or two, your understanding of how to best operate your stove or insert will enhance its overall efficiency and performance. What this can mean to you is longer, cleaner burns, less wood use, and more heat.

GETTING THE MOST OUT OF YOUR STOVE

The following sections will outline techniques you can use to "get the most out of your stove." Please read them carefully.

MAXIMIZING YOUR STOVE'S OVERALL EFFICIENCY

It is important to know that for high, combustion efficient, clean burns, you will need to have sufficient temperatures inside the firebox for thorough combustion. The best method for determining if you have sufficient temperatures is to watch the brick lining in your firebox. When you first light your stove, the bricks will turn a dark brown or black. After 20 to 30 minutes of a hot fire, most of the bricks should return to near their original light brown or yellow color. This means the bricks have reached a high enough temperature for your stove to achieve high combustion efficiency.

Second, and just as important, is achieving a high level of heat transfer efficiency. Slowing the rate of flow through the stove or insert enhances heat transfer, thus allowing more time for heat to be transferred into your home. To do this, be sure to thoroughly preheat your stove and then reduce the amount of primary air by closing the draft control (lower left) to about 1/2 to 3/4 open. This will decrease the excess oxygen in your flue, which carries heat up your chimney, but should still be enough air to allow the stove to produce its maximum heat output. (More air may produce a lightly greater amount of heat, but will greatly increase wood consumption). When the area being heated reaches a comfortable temperature, slow the burn rate by closing the control to further improve heat transfer.

To get the most out of your Country™ Collection stove, you will need to combine good combustion efficiency with good heat transfer practices. The following are some tips on how to operate your stove to achieve the highest overall efficiency.

1. Thoroughly preheat your stove before slowing the burn rate by closing the draft control.
2. Measure the stove temperature at the hottest point on the stove top or face. Use this information to repeat burn rates.
3. Once preheated, add wood (if needed) and partially close the draft control (lower left).
4. Operate your stove as much as possible in the low to medium burn ranges.
5. Do not lower the draft setting so low as to completely extinguish the flames in the firebox. Check for at least some small flames 20 minutes after setting the draft control.
6. Do not continually operate your stove in the high (wide open) setting. This wastes wood by carrying a great deal of heat up the chimney and can damage your stove and chimney.
7. Go outside and check your chimney. More than a very small amount of smoke indicates wasted heat, creosote build-up, and pollution.

ACHIEVING CLEAN, LONG BURNS

To achieve long burn times, after having thoroughly preheated the stove, let the stove top cool down to 275 to 400 degrees (on Elites, locate thermometer on the face of the insert just above the door). Now load the firebox and set the draft control. At this point, you may need to burn the stove with the draft open for a few minutes to ignite the wood. All Country Collection stoves are EPA tested for emissions at low burn with the air control completely closed. Whether or not you should burn your stove with the air control completely closed will depend on the following factors.

- * How you load your wood.
- * Your chimney type, height, and draft.
- * Your wood type and its moisture content.
- * The temperature of the stove.
- * Which model Stove or insert you have.

Experiment with different loading configurations to achieve longer burns. Try loading the wood from side to side and nesting it in the ashes to prevent airflow under and around the wood. Fresh wood should be loaded to the back of the firebox or to the sides. Hot coals or half burned wood should be brought towards the front of the firebox. The way you load your wood can seriously affect burn times. If the new load does not ignite within a few minutes, try crisscrossing the load to allow more airflow around the fire, or try a slightly hotter stove temperature.

Determining the lowest setting for efficient low burns. This will require some experimentation on your part. Try closing the air control all the way with the stove temperature at 325 to 350 degrees. If the flames are completely extinguished, open the air control halfway and then slowly close it until there is only a small amount of flame. It is important to check the stove about 20 minutes after setting the draft control as it takes this long for the stove temperature to stabilize. There should still be some small flames on or above the wood load.

Use 325 degrees as a starting point. You can try starting temperatures 25 degrees higher or lower to achieve desired burn times, start 25 degrees lower if the stove burns the wood too quickly or 25 degrees higher if there are no flames in the firebox for more than a few minutes after loading the wood. You may or may not need to burn the stove with the air control open for a few minutes prior to setting the draft for a low burn, this will depend on the factors mentioned above. **Be sure not to smolder a fire overnight. Check your chimney for large amounts of smoke as this indicates very poor combustion.**

It is important to realize that stove technology has changed. Stoves have changed a great deal in the last few years. This has led to substantial changes in the methods of operation in new stoves as compared to older stoves. In old stoves without full brick linings and ceramic insulation, the rule was "get the stove as hot as possible before setting the draft on low for overnight burns." On newer, high technology Country™ Collection stoves, this is not necessary. Although it is still important to have the stove hot enough to burn efficiently, it will require less preheating. Once you have determined your optimum operating temperatures for various burn rates, we believe you will find your stove an extremely convenient way to achieve your heating needs.

Do not reload the stove for long burns when the stainless secondary tubes or baffle supports are glowing red, or when the stove is uncomfortably hot to load. This indicates the stove is too hot to load for a long burn. Also, do not load wood for a long burn on a deep bed of hot coals. Try stirring the coals a few minutes before loading the stove for a low burn to allow some of the unburned coals time to burn.

MAINTENANCE

DOOR HINGES: If door hinges need lubricating, use an anti-seize compound (never use oil) available from your Lennox Hearth Products dealer.

DOOR LATCH: If your door latch fails to latch tightly and the gasket is in good condition, place a length of pipe (cheater bar) over the inside portion of the door handle and bend slightly toward the door until the proper adjustment is obtained. If the door handle does not close easily, apply high temperature anti-seize to the striker.

DOOR GASKET: Periodically check gasket to make sure it is not over-compressed. If compressed, replace with a special woven Door Rope. (Don't try substituting rope, only use special Lennox Hearth Products Door Rope).

GOLD OR NICKEL PLATED DOOR: Clean only with WIN-DEX brand glass cleaner and a very soft cotton cloth. Other products may damage brass, paint, and gaskets.

INSULATING BLANKETS: Your insulating blanket should be inspected during every chimney cleaning. If the blanket is compressed or heavily stained, it should be replaced. Heavy creosote stains or matting is an indication of improper use and your burning habits should be reviewed.

GLASS CLEANING: Only clean glass with products specifically made to use on wood stoves. Other products could damage gaskets and paint. Never scrape glass with a razor blade. This can pit the glass and make it impossible to clean in the future.

WINDOW GASKET: The window gasket can be checked by running the flame of a match near the gasket and around the door. If the flame is drawn in around the window, the gasket should be replaced.

DOOR HANDLE: Door handle may become tight as you use the stove. Free the handle up by using dry graphite supplied with the stove. The directions are included with the graphite.

TROUBLESHOOTING

PROBLEM

SOLUTION

POOR DRAFT:

Extend chimney in length or have the chimney realigned to the proper size flue. Oversized chimneys normally have poor drafts. Remember, the stoves' draft depend solely on the natural draft of the chimney (See Drafting section on page 4). If your stove is not drafting properly, your chimney is the problem. All stoves are thoroughly tested to ensure proper draft with the correct size chimney flue.

EXCESSIVE DRAFT:

With better chimneys being more common, excessive draft can be an issue. Alleviate excessive draft by slowing the burn rate of the stove once it has reached proper operating temperature (See Maximizing Your Stoves Overall Efficiency on page 16).

DIRTY GLASS:

- 1) Burn smaller, hotter fires and check to make sure you are not setting the draft down too far with the draft control.
- 2) Make sure your wood is well-seasoned and dry (not open to rain - see Creosote and Fuel sections on page 3).
- 3) See Poor Draft section (above) and Clean Glass on page 15 .

SMOKES WHEN DOOR IS OPEN:

- 1) If smoke is entering the room, check to make sure your baffle bricks are properly installed and that the insulating blanket is pushed back flush with the front of the baffle brick.
- 2) Check the chimney for blockage due to creosote (see Chimney & Creosote sections on pages 3 and 4).
- 3) Check draft (See POOR DRAFT section above).

WOOD BURNS TOO FAST:

- 1) The draft control must be closed further.
- 2) Add fuel at lower firebox temperatures.
- 3) Load wood side to side and reduce the flow of air under wood.
- 4) The door seal may need replacing, check for leakage.
- 5) See "Excessive Draft."

POOR HEAT OUTPUT:

- 1) Check your wood. Wet, moist, unseasoned wood will not produce heat.
- 2) Your stove needs to be seasoned (moisture removed from the steel and brick). Continue to burn a fire. It normally takes from one to three weeks of burning to season your stove (See Break-in Procedures on page 5).
- 3) See Excessive Draft section above.

PAINT GIVES OFF ODOR (smoke):

Paint is tempering-in. Burn only moderately hot for the first few days until paint is fully cured. Then burn a very hot fire to cure any paint that may not easily cure. Open windows or door to ventilate (See Break-in Procedures on page 5).

DO'S AND DON'TS

- DO NOT:** Install or operate this stove before reading this manual.
- DO NOT:** Close the draft beyond the point at which the flames are completely extinguished.
- DO NOT:** Open the stove door without fully opening the draft first.
- DO NOT:** Burn driftwood or wood that has been in salt water. This includes some mill ends and scrap lumber that has been floated in salt water on the way to the mill. (This will void your warranty).
- DO NOT:** Handle the Nickel or Gold faceplate unnecessarily. Use the door handle only.
- DO NOT:** Force oversized logs into the firebox as this may dislodge the baffle assembly.
- DO NOT:** Close the door tightly during break-in period.

- DO:** Be sure to clean any fingerprints from the Gold or Nickel faceplate before burning the stove. Clean the Gold or Nickel door only with Windex and a very soft cloth.
- DO:** Consult local building department if other than recommended clearances are desired.
- DO:** Read instructions for the brick baffles occasionally to ensure you have not bumped or moved them out of place when loading wood.
- DO:** Check the chimney and baffle a minimum of every 3 months to make sure they are clean.
- DO:** Burn seasoned, dry wood only! (RAIN = WET WOOD)
- DO:** Complete and return your warranty card.
- DO:** Open the door frequently during break-in period to keep gasket from adhering to the curing paint.
- DO:** Enjoy the warm feeling of your new Country™ Collection stove.

The manufacturer reserves the right to make changes at any time, without notice, in design, materials, specifications, prices and also to discontinue colors, styles and products. Consult your local distributor for fireplace code information.



HEARTH PRODUCTS

1110 West Taft Avenue • Orange, CA 92865

Printed in U.S.A. © 2007 by Lennox Hearth Products

P/N 775,214M REV. B 09/2007

Free Manuals Download Website

<http://myh66.com>

<http://usermanuals.us>

<http://www.somanuals.com>

<http://www.4manuals.cc>

<http://www.manual-lib.com>

<http://www.404manual.com>

<http://www.luxmanual.com>

<http://aubethermostatmanual.com>

Golf course search by state

<http://golfingnear.com>

Email search by domain

<http://emailbydomain.com>

Auto manuals search

<http://auto.somanuals.com>

TV manuals search

<http://tv.somanuals.com>