

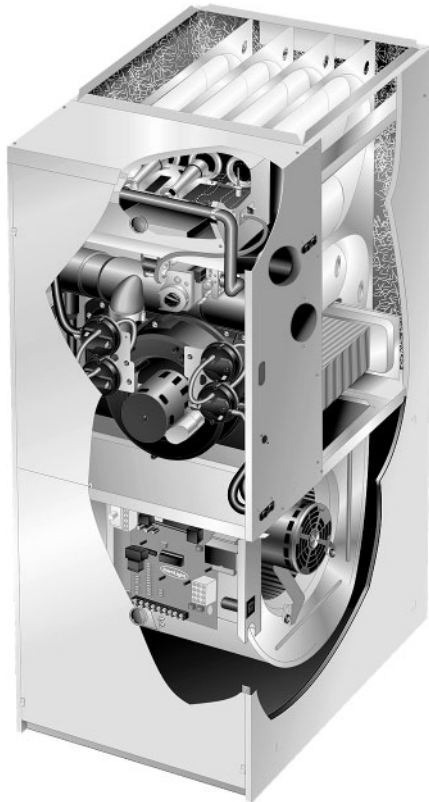

© 2009 Lennox Industries Inc.
Dallas, Texas, USA

INSTALLATION INSTRUCTIONS

G61MP SERIES UNITS



GAS UNITS
506406-01
08/2009
Supersedes 505,124M

TP Technical
Publications
Litho U.S.A.

Table of Contents

Unit Dimensions	2
G61MP Parts Identification	3
Shipping and Packing List	4
Safety Information	4
Use of Furnace as Construction Heater	5
General	6
Combustion, Dilution & Ventilation Air	6
Installation - Setting Equipment	8
Filters	16
Duct System	16
Pipe & Fittings Specifications	16
Vent Piping Guidelines	18
Joint Cementing Procedure	20
Venting Practices	21
Gas Piping	33
Electrical	35
Integrated Control Board	42
Unit Start-Up	42
Gas Pressure Adjustment	44
High Altitude Information	45
Other Unit Adjustments	46
Service	53
Ignition Control Board Diagnostic Codes	56
Troubleshooting	57
Repair Parts List	62
Vent Pipe Sizing Worksheet	63
Start-Up & Performance Check List	63

**THIS MANUAL MUST BE LEFT WITH THE
HOMEOWNER FOR FUTURE REFERENCE**



⚠ WARNING

FIRE OR EXPLOSION HAZARD.



Failure to follow safety warnings exactly could result in serious injury, death, or property damage.



Do not store or use gasoline or other flammable vapors and liquids in the vicinity of this or any other appliance.

Installation and service must be performed by a qualified installer, service agency or the gas supplier.

WHAT TO DO IF YOU SMELL GAS:

- Do not try to light any appliance.
- Do not touch any electrical switch; do not use any phone in your building.
- Leave the building immediately.
- Immediately call your gas supplier from a neighbor's phone. Follow the gas supplier's instructions.
- If you cannot reach your gas supplier, call the fire department.



G61MP Unit Dimensions - inches (mm)

***NOTE - 60C and 60D size units installed in upflow applications that require air volumes over 1800 cfm (850 L/s) must have one of the following:**

1. Single side return air with transition, to accommodate 20 x 25 x 1 in. (508 x 635 x 25 mm) air filter. Required to maintain proper air velocity.
2. Single side return air with optional RAB Return Air Base
3. Bottom return air.
4. Return air from both sides.
5. Bottom and one side return air.

Refer to Engineering Handbook for additional information.

****Consider sizing requirements for optional IAQ equipment before cutting side return opening.**

¹ Optional External Side Return Air Filter Kit is not for use with the optional RAB Return Air Base.

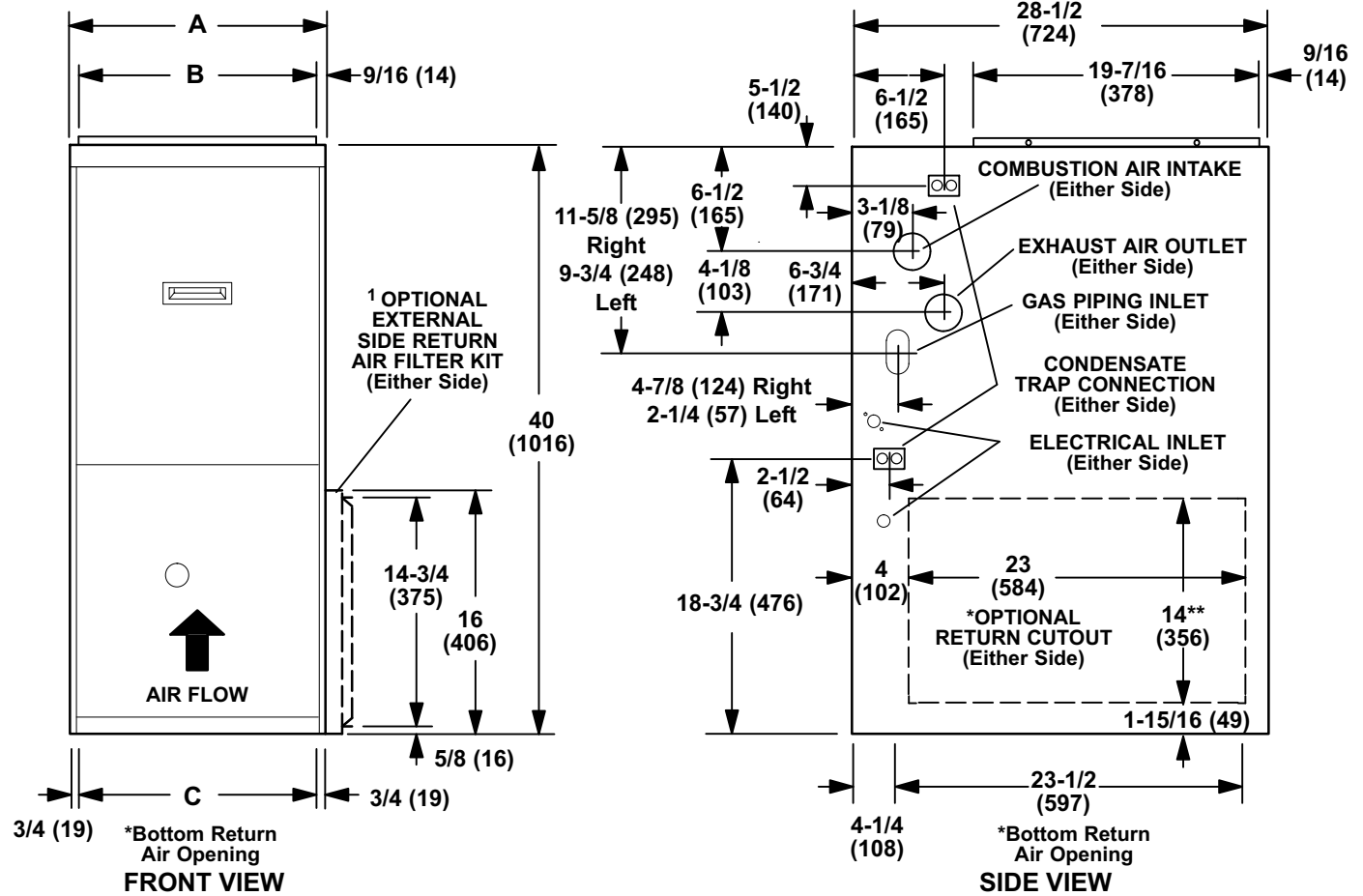
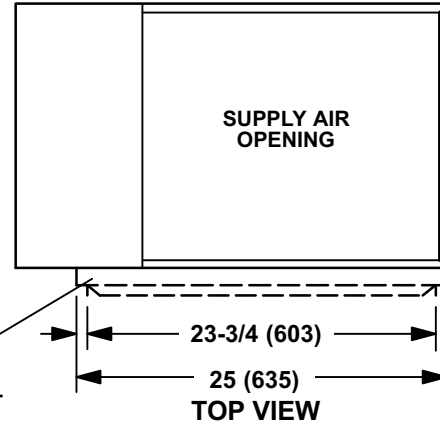

Model No.	A		B		C	
	in.	mm	in.	mm	in.	mm
G61MP-36B-045 G61MP-36B-070 G61MP-36B-071	17-1/2	446	16-3/8	416	16	406
G61MP-48C-090 G61MP-60C-090 G61MP-60C-091 G61MP-48C-110 G61MP-60C-110 G61MP-60C-111	21	533	19-7/8	505	19-1/2	495
G61MP-60D-135	24-1/2	622	23-3/8	546	23	584

G61MP PARTS IDENTIFICATION

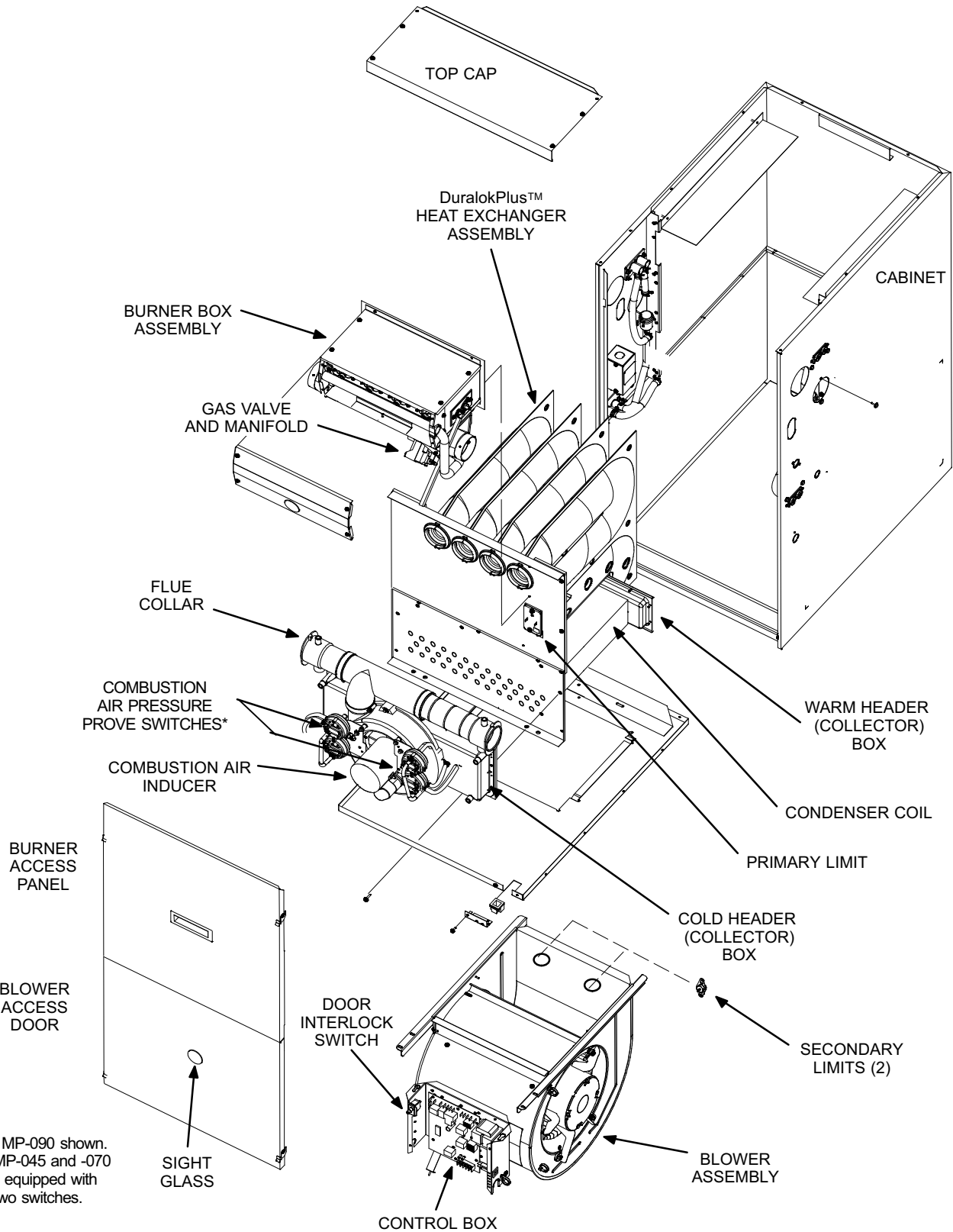

*G61MP-090 shown. G61MP-045 and -070 are equipped with two switches.

FIGURE 1

G61MP Gas Furnace

The G61MP category IV gas furnace is shipped ready for installation in the upflow, downflow, horizontal left air discharge or horizontal right air discharge position. The furnace is shipped with the bottom panel in place. The bottom panel must be removed if the unit is to be installed in upflow applications with bottom return air. The bottom panel must also be removed and discarded in all downflow or horizontal applications.

The furnace is equipped for installation in natural gas applications. A conversion kit (ordered separately) is required for use in propane/LP gas applications.

The G61MP can be installed as either a Direct Vent or a Non-Direct Vent gas central furnace.

NOTE - In Direct Vent installations, combustion air is taken from outdoors and flue gases are discharged outdoors. In Non-Direct Vent installations, combustion air is taken from indoors and flue gases are discharged outdoors. See figure 2 for applications involving roof termination.

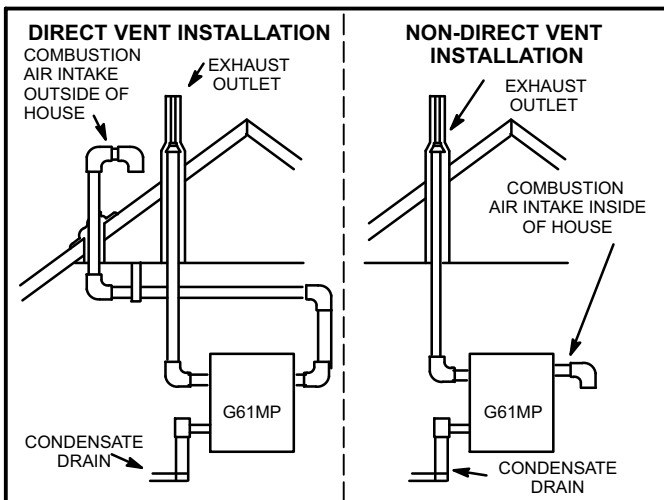

FIGURE 2

Shipping and Packing List

Package 1 of 1 contains

- 1 - Assembled G61MP unit
- 1 - Bag assembly containing the following:
 - 3 - Screws
 - 3 - Wire nuts
 - 1 - Snap bushing
 - 1 - Snap plug
 - 1 - Wire tie
 - 1 - Condensate trap
 - 1 - Condensate trap cap
 - 2 - 2" diameter vent / intake plugs
 - 1 - 3" diameter cabinet plug (intake)
 - 1 - 2" diameter debris screen
 - 1 - Logo sticker (for use in downflow applications)

NOTE - G61MP-48C-110, G61MP-60C-110 and G61MP-60C-111 units also include a 2" diameter PVC street elbow, which is shipped on the blower deck in the heating compartment. G61MP-60D-135 units are shipped with a 3" to 2" PVC reducing elbow.

Canadian Installations Only - Replace the provided 2" street elbow shipped with the G61MP-48C-110, G61MP-60C-110 and G61MP-60C-111 units with 2" street elbow Y0162. Replace the provided 3" X 2" reducing elbow shipped with the G61MP-60D-135 units with 3" X 2" reducing elbow 40W22. Y0162 and 40W22 meet B149 vent requirements.

Check equipment for shipping damage. If you find any damage, immediately contact the last carrier.

The following items may also be ordered separately:

- 1 - Thermostat
- 1 - Propane/LP changeover kit

⚠ DANGER

Danger of explosion.

There are circumstances in which odorant used with LP/propane gas can lose its scent. In case of a leak, LP/propane gas will settle close to the floor and may be difficult to smell. An LP/propane leak detector should be installed in all LP applications.

Safety Information

⚠ WARNING

Improper installation, adjustment, alteration, service or maintenance can cause property damage, personal injury or loss of life. Installation and service must be performed by a licensed professional installer (or equivalent), service agency or the gas supplier.

⚠ CAUTION

As with any mechanical equipment, personal injury can result from contact with sharp sheet metal edges. Be careful when you handle this equipment.

Use only the type of gas approved for use with this furnace. Refer to unit nameplate.

G61MP units are CSA International certified to ANSI Z21.47 and CSA 2.3 standards.

In the USA, installation of gas furnaces must conform with local building codes. In the absence of local codes, units must be installed according to the current National Fuel Gas Code (ANSI-Z223.1/NFPA 54). The National Fuel Gas Code is available from the following address:

American National Standards Institute, Inc.
11 West 42nd Street
New York, NY 10036

In Canada, installation must conform with current National Standard of Canada CSA-B149 Natural Gas and Propane Installation Codes, local plumbing or waste water codes and other applicable local codes.

In order to ensure proper unit operation in non-direct vent applications, combustion and ventilation air supply must be provided according to the current National Fuel Gas Code or CSA-B149 standard.

This furnace is CSA International certified for installation clearances to combustible material as listed on the unit nameplate and in the tables in figures 8, 13 and 17. Accessibility and service clearances must take precedence over fire protection clearances.

NOTE - For installation on combustible floors, the furnace shall not be installed directly on carpeting, tile, or other combustible material other than wood flooring.

For installation in a residential garage, the furnace must be installed so that the burner(s) and the ignition source are located no less than 18 inches (457 mm) above the floor. The furnace must be located or protected to avoid physical damage by vehicles. When a furnace is installed in a public garage, hangar, or other building that has a hazardous atmosphere, the furnace must be installed according to recommended good practice requirements and current National Fuel Gas Code or CSA B149 standard.

NOTE - Furnace must be adjusted to obtain a temperature rise within the range specified on the unit nameplate. Failure to do so may cause erratic limit operation.

This G61MP furnace may be used as a high-static unit heater. The G61MP may also be installed in an aircraft hangar in accordance with the Standard for Aircraft Hangars (ANSI/NFPA No. 408-1990).

Installation in parking structures must be in accordance with the Standard for Parking Structures (ANSI/NFPA No. 88A-1991). Installation in repair garages must be in accordance with the Standard for Repair Garages (ANSI/NFPA No. 88B-1991).

This G61MP furnace must be installed so that its electrical components are protected from water.

When this furnace is used with cooling units, it shall be installed in parallel with, or on the upstream side of, cooling units to avoid condensation in the heating compartment. With a parallel flow arrangement, a damper (or other means to control the flow of air) must adequately prevent chilled air from entering the furnace. If the damper is manually operated, it must be equipped to prevent operation of either the heating or the cooling unit, unless it is in the full **HEAT** or **COOL** setting.

When installed, this furnace must be electrically grounded according to local codes. In addition, in the United States, installation must conform with the current National Electric Code, ANSI/NFPA No. 70. The National Electric Code (ANSI/NFPA No. 70) is available from the following address:

National Fire Protection Association
1 Battery March Park
Quincy, MA 02269

In Canada, all electrical wiring and grounding for the unit must be installed according to the current regulations of the Canadian Electrical Code Part I (CSA Standard C22.1) and/or local codes.

NOTE - This furnace is designed for a minimum continuous return air temperature of 60°F (16°C) or an intermittent operation down to 55°F (13°C) dry bulb for cases where a night setback thermostat is used. Return air temperature must not exceed 85°F (29°C) dry bulb.

The G61MP furnace may be installed in alcoves, closets, attics, basements, garages, and utility rooms.

This furnace design has not been CSA certified for installation in mobile homes, recreational vehicles, or outdoors.

Never use an open flame to test for gas leaks. Check all connections using a commercially available soap solution made specifically for leak detection.

Use of Furnace as Construction Heater

Lennox does not recommend the use of G61MP units as a construction heater during any phase of construction. Very low return air temperatures, harmful vapors and operation of the unit with clogged or misplaced filters will damage the unit.

G61MP units may be used for heating of buildings or structures under construction, if the following conditions are met:

- The vent system must be permanently installed per these installation instructions.
- A room thermostat must control the furnace. The use of fixed jumpers that will provide continuous heating is not allowed.
- The return air duct must be provided and sealed to the furnace.
- Return air temperature range between 60°F (16°C) and 80°F (27°C) must be maintained.
- Air filters must be installed in the system and must be maintained during construction.
- Air filters must be replaced upon construction completion.
- The input rate and temperature rise must be set per the furnace rating plate.

- One hundred percent (100%) outdoor air must be provided for combustion air requirements during construction. Temporary ducting may supply outdoor air to the furnace. Do not connect duct directly to the furnace. Size the temporary duct following these instructions in section for Combustion, Dilution and Ventilation Air in a confined space with air from outside.
- The furnace heat exchanger, components, duct system, air filters and evaporator coils must be thoroughly cleaned following final construction clean-up.
- All furnace operating conditions (including ignition, input rate, temperature rise and venting) must be verified according to these installation instructions.

General

These instructions are intended as a general guide and do not supersede local codes in any way. Consult authorities having jurisdiction before installation.

In addition to the requirements outlined previously, the following general recommendations must be considered when installing a G61MP furnace:

- Place the furnace as close to the center of the air distribution system as possible. The furnace should also be located close to the chimney or vent termination point.
- When the furnace is installed in non-direct vent applications, do not install the furnace where drafts might blow directly into it. This could cause improper combustion and unsafe operation.
- When the furnace is installed in non-direct vent applications, do not block the furnace combustion air opening with clothing, boxes, doors, etc. Air is needed for proper combustion and safe unit operation.
- When the furnace is installed in an attic or other insulated space, keep insulation away from the furnace.
- When the furnace is installed in an unconditioned space, consider provisions required to prevent freezing of condensate drain system.

⚠ WARNING

Product contains fiberglass wool.

Disturbing the insulation in this product during installation, maintenance, or repair will expose you to fiberglass wool. Breathing this may cause lung cancer. (Fiberglass wool is known to the State of California to cause cancer.)

Fiberglass wool may also cause respiratory, skin, and eye irritation.

To reduce exposure to this substance or for further information, consult material safety data sheets available from address shown below, or contact your supervisor.

**Lennox Industries Inc.
P.O. Box 799900
Dallas, TX 75379-9900**

⚠ CAUTION

G61MP unit should not be installed in areas normally subject to freezing temperatures.

Combustion, Dilution & Ventilation Air

If the G61MP is installed as a Non-Direct Vent Furnace, follow the guidelines in this section.

NOTE - In Non-Direct Vent installations, combustion air is taken from indoors and flue gases are discharged outdoors.

⚠ WARNING

Insufficient combustion air can cause headaches, nausea, dizziness or asphyxiation. It will also cause excess water in the heat exchanger resulting in rusting and premature heat exchanger failure. Excessive exposure to contaminated combustion air will result in safety and performance related problems. Avoid exposure to the following substances in the combustion air supply:

**Permanent wave solutions
Chlorinated waxes and cleaners
Chlorine base swimming pool chemicals
Water softening chemicals
De-icing salts or chemicals
Carbon tetrachloride
Halogen type refrigerants
Cleaning solvents (such as perchloroethylene)
Printing inks, paint removers, varnishes, etc.
Hydrochloric acid
Cements and glues
Antistatic fabric softeners for clothes dryers
Masonry acid washing materials**

In the past, there was no problem in bringing in sufficient outdoor air for combustion. Infiltration provided all the air that was needed. In today's homes, tight construction practices make it necessary to bring in air from outside for combustion. Take into account that exhaust fans, appliance vents, chimneys, and fireplaces force additional air that could be used for combustion out of the house. Unless outside air is brought into the house for combustion, negative pressure (outside pressure is greater than inside pressure) will build to the point that a downdraft can occur in the furnace vent pipe or chimney. As a result, combustion gases enter the living space creating a potentially dangerous situation.

In the absence of local codes concerning air for combustion and ventilation, use the guidelines and procedures in this section to install G61MP furnaces to ensure efficient and safe operation. You must consider combustion air needs and requirements for exhaust vents and gas piping. A portion of this information has been reprinted with permission from the National Fuel Gas Code (ANSI-

Z223.1/NFPA 54). This reprinted material is not the complete and official position of the ANSI on the referenced subject, which is represented only by the standard in its entirety.

In Canada, refer to the standard CSA B149 installation codes.

⚠ CAUTION

Do not install the furnace in a corrosive or contaminated atmosphere. Meet all combustion and ventilation air requirements, as well as all local codes.

All gas-fired appliances require air for the combustion process. If sufficient combustion air is not available, the furnace or other appliance will operate inefficiently and unsafely. Enough air must be provided to meet the needs of all fuel-burning appliances and appliances such as exhaust fans which force air out of the house. When fireplaces, exhaust fans, or clothes dryers are used at the same time as the furnace, much more air is required to ensure proper combustion and to prevent a downdraft. Insufficient air causes incomplete combustion which can result in carbon monoxide.

In addition to providing combustion air, fresh outdoor air dilutes contaminants in the indoor air. These contaminants may include bleaches, adhesives, detergents, solvents and other contaminants which can corrode furnace components.

The requirements for providing air for combustion and ventilation depend largely on whether the furnace is installed in an unconfined or a confined space.

Unconfined Space

An unconfined space is an area such as a basement or large equipment room with a volume greater than 50 cubic feet (1.42 m³) per 1,000 Btu (.29 kW) per hour of the combined input rating of all appliances installed in that space. This space also includes adjacent rooms which are not separated by a door. Though an area may appear to be unconfined, it might be necessary to bring in outdoor air for combustion if the structure does not provide enough air by infiltration. If the furnace is located in a building of tight construction with weather stripping and caulking around the windows and doors, follow the procedures in the air from outside section.

Confined Space

A confined space is an area with a volume less than 50 cubic feet (1.42 m³) per 1,000 Btu (.29 kW) per hour of the combined input rating of all appliances installed in that space. This definition includes furnace closets or small equipment rooms. When the furnace is installed so that supply ducts carry air circulated by the furnace to areas outside the space containing the furnace, the return air **must be** handled by ducts

which are sealed to the furnace casing and which terminate outside the space containing the furnace. This is especially important when the furnace is mounted on a platform in a confined space such as a closet or small equipment room. Even a small leak around the base of the unit at the platform or at the return air duct connection can cause a potentially dangerous negative pressure condition. Air for combustion and ventilation can be brought into the confined space either from inside the building or from outside.

Air from Inside

If the confined space that houses the furnace adjoins a space categorized as unconfined, air can be brought in by providing two permanent openings between the two spaces. Each opening must have a minimum free area of 1 square inch (645 mm²) per 1,000 Btu (.29 kW) per hour of total input rating of all gas-fired equipment in the confined space. Each opening must be at least 100 square inches (64516 mm²). One opening shall be within 12 inches (305 mm) of the top of the enclosure and one opening within 12 inches (305 mm) of the bottom. See figure 3.

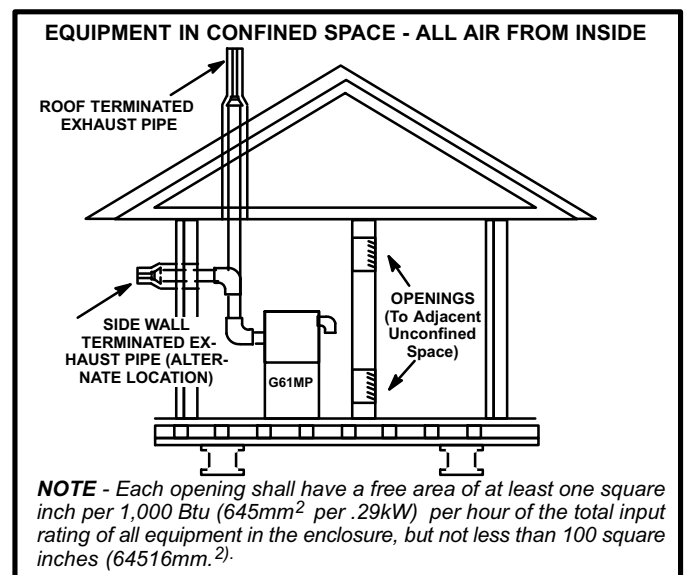

FIGURE 3

Air from Outside

If air from outside is brought in for combustion and ventilation, the confined space shall be provided with two permanent openings. One opening shall be within 12" (305mm) of the top of the enclosure and one within 12" (305mm) of the bottom. These openings must communicate directly or by ducts with the outdoors or spaces (crawl or attic) that freely communicate with the outdoors or indirectly through vertical ducts. Each opening shall have a minimum free area of 1 square inch per 4,000 Btu (645mm² per 1.17kW) per hour of total input rating of all equipment in the enclosure. When communicating with the outdoors through horizontal ducts, each opening shall have a minimum free area of 1 square inch per 2,000 Btu (645mm² per .59kW) per total input rating of all equipment in the enclosure (See figure 4).

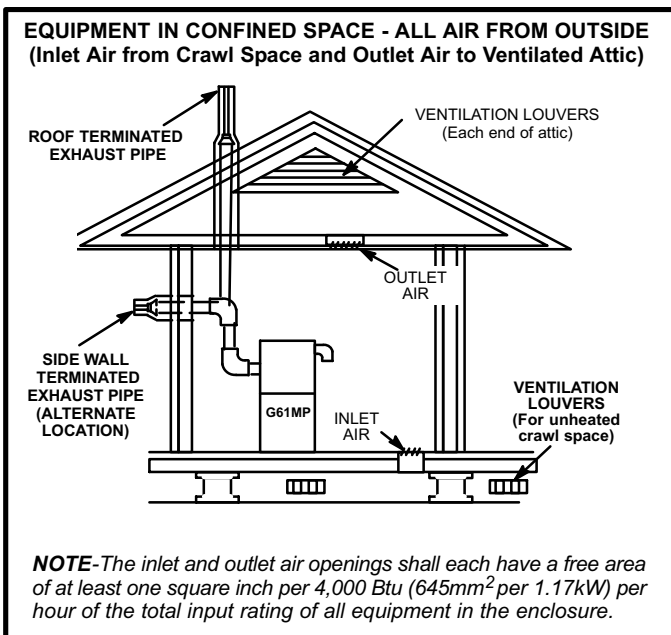

FIGURE 4

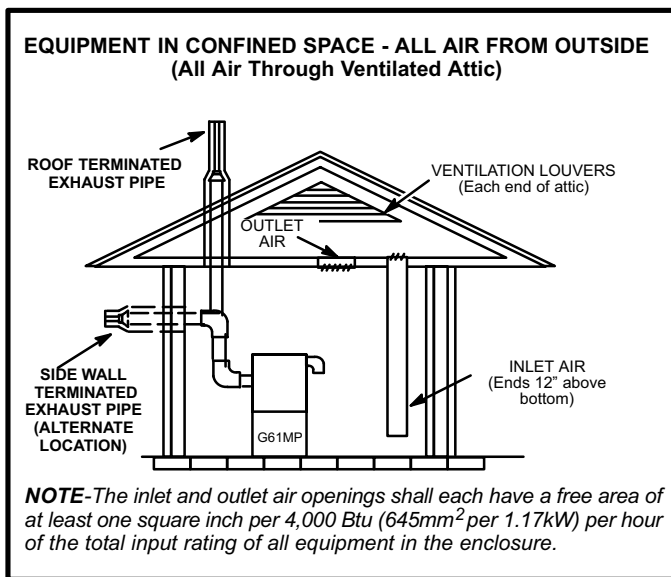

FIGURE 5

If air from outside is brought in for combustion and ventilation, the confined space must have two permanent openings. One opening shall be within 12 inches (305 mm) of the top of the enclosure and one opening within 12 inches (305 mm) of the bottom. These openings must communicate directly or by ducts with the outdoors or spaces (crawl or attic) that freely communicate with the outdoors or indirectly through vertical ducts. Each opening shall have a minimum free area of 1 square inch (645 mm²) per 4,000 Btu (1.17 kW) per hour of total input rating of all equipment

in the enclosure. See figures 4 and 5. When communicating with the outdoors through horizontal ducts, each opening shall have a minimum free area of 1 square inch (645 mm²) per 2,000 Btu (.56 kW) per total input rating of all equipment in the enclosure. See figure 6.

When ducts are used, they shall be of the same cross-sectional area as the free area of the openings to which they connect. The minimum dimension of rectangular air ducts shall be no less than 3 inches (75 mm). In calculating free area, the blocking effect of louvers, grilles, or screens must be considered. If the design and free area of protective covering is not known for calculating the size opening required, it may be assumed that wood louvers will have 20 to 25 percent free area and metal louvers and grilles will have 60 to 75 percent free area. Louvers and grilles must be fixed in the open position or interlocked with the equipment so that they are opened automatically during equipment operation.

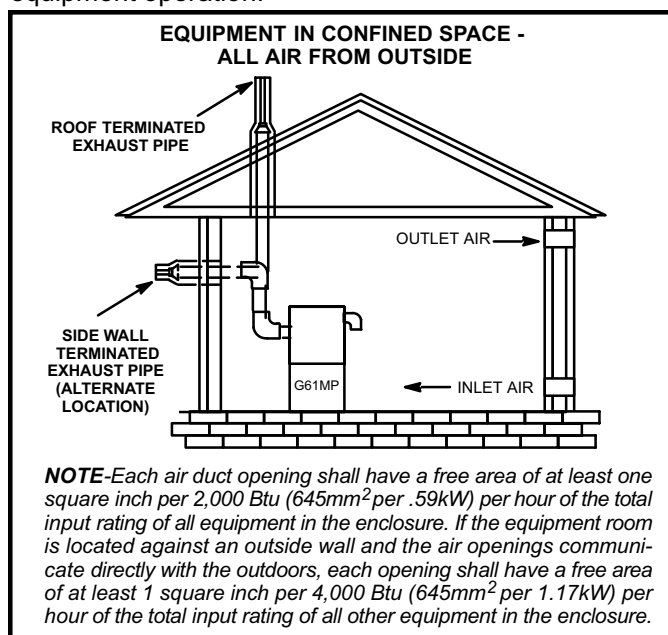

FIGURE 6

Installation - Setting Equipment

⚠ WARNING

Do not install the furnace on its front or its back. Do not connect the return air ducts to the back of the furnace. Doing so will adversely affect the operation of the safety control devices, which could result in personal injury or death.

Select a location that allows for the required clearances that are listed on the unit nameplate. Also consider gas supply connections, electrical supply, vent connection, condensate trap and drain connections, and installation and service clearances [24 inches (610 mm) at unit front].

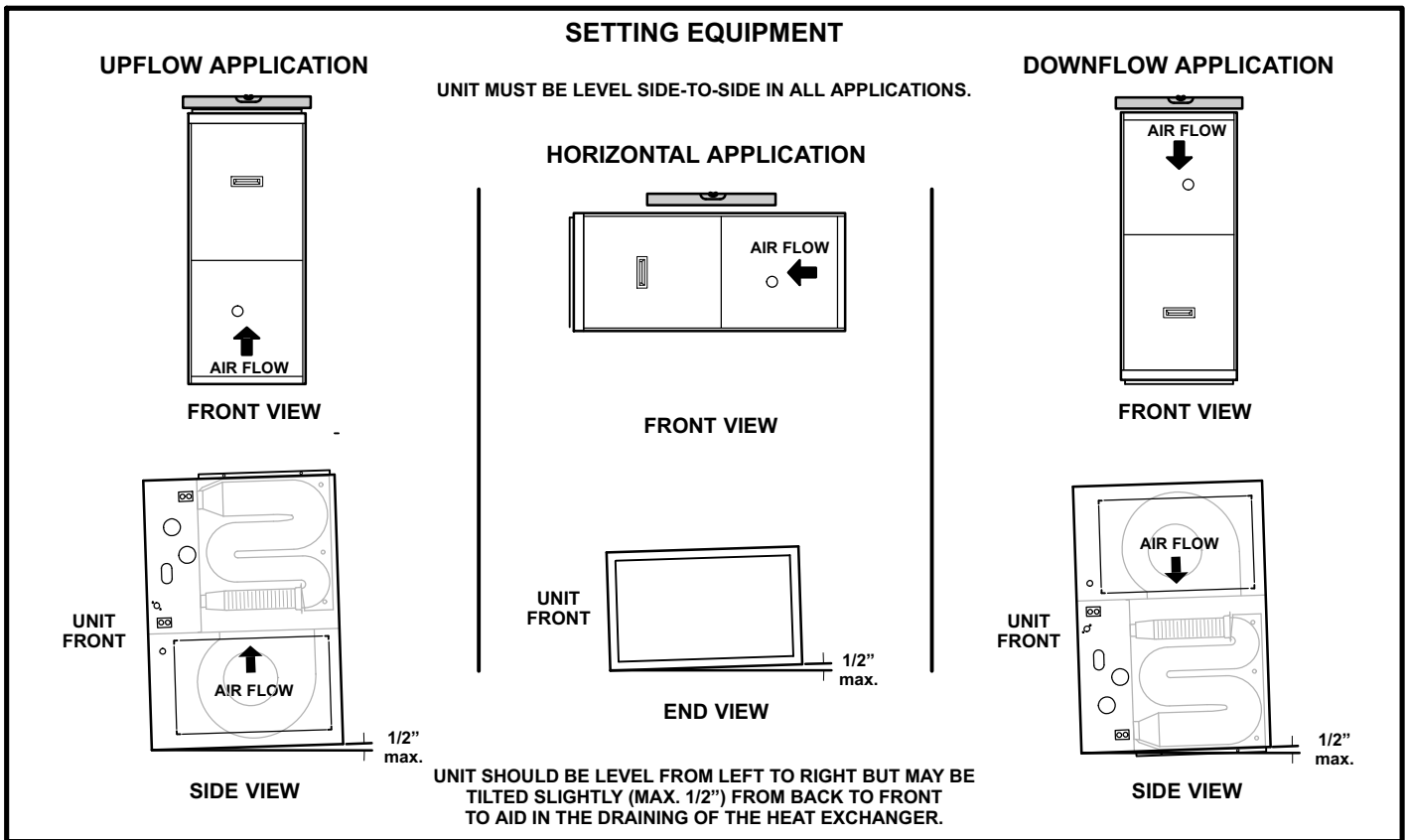

FIGURE 7

The unit must be level from side to side. The unit may be tilted slightly (maximum 1/2 in.) from back to front to aid in the draining of the heat exchanger. See figure 7.

NOTE - Units with 1/2 hp blower motors are equipped with three flexible legs and one rigid leg. The rigid leg is equipped with a shipping bolt and a flat white plastic washer (rather than the rubber mounting grommet used with a flexible mounting leg). **The bolt and washer must be removed before the furnace is placed into operation.** After the bolt and washer have been removed, the rigid leg will not touch the blower housing.

⚠ WARNING

Blower access panel must be securely in place when blower and burners are operating. Gas fumes, which could contain carbon monoxide, can be drawn into living space resulting in personal injury or death.

Allow for clearances to combustible materials as indicated on the unit nameplate. Minimum clearances for closet or alcove installations are shown in figures 8, 13 and 17.

⚠ WARNING

Improper installation of the furnace can result in personal injury or death. Combustion and flue products must never be allowed to enter the return air system or air in the living space. Use sheet metal screws and joint tape to seal return air system to furnace. In platform installations with furnace return, the furnace should be sealed airtight to the return air plenum. A door must never be used as a portion of the return air duct system. The base must provide a stable support and an airtight seal to the furnace. Allow absolutely no sagging, cracks, gaps, etc. For no reason should return and supply air duct systems ever be connected to or from other heating devices such as a fireplace or stove, etc. Fire, explosion, carbon monoxide poisoning, personal injury and/or property damage could result.

Upflow Applications

The G61MP gas furnace can be installed as shipped in the upflow position. Refer to figure 8 for clearances.

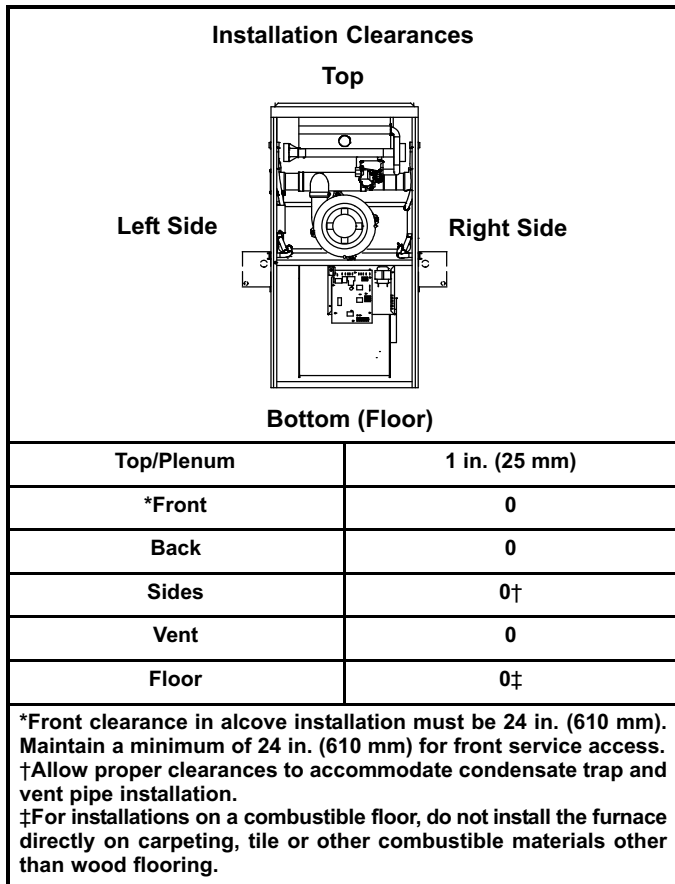

FIGURE 8

Return Air -- Upflow Units

Return air can be brought in through the bottom or either side of the furnace installed in an upflow application. If the furnace is installed on a platform with bottom return, make an airtight seal between the bottom of the furnace and the platform to ensure that the furnace operates properly and safely. The furnace is equipped with a removable bottom panel to facilitate installation.

Markings are provided on both sides of the furnace cabinet for installations that require side return air. Cut the furnace cabinet at the maximum dimensions shown on page 2.

NOTE - When air volumes over 1800 cfm (850 L/s) are required with 60C or 60D models in an upflow application, the following return air options are available:

- 1 - Return air from single side with transition which will accommodate 20 x 25 x 1 in. (508 x 635 x 25 mm) air filter. (Required to maintain proper air velocity.) See figure 10.
- 2 - Return air from single side with optional RAB Return Air Base. See figure 9.
- 3 - Return air from bottom.
- 4 - Return air from both sides.
- 5 - Return air from bottom and one side.

Refer to Engineering Handbook for additional information.

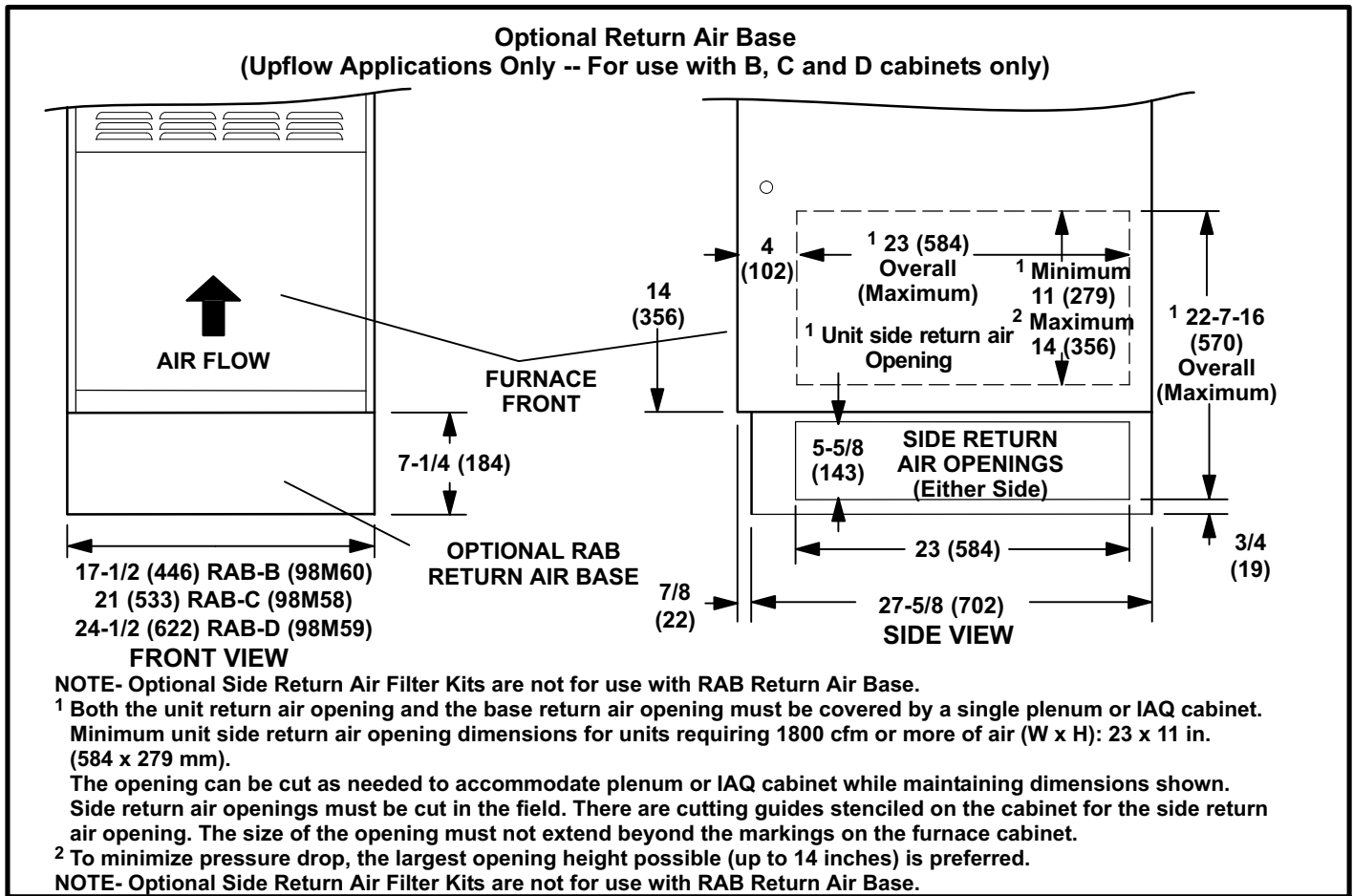

FIGURE 9

G61MP applications which include side return air and a condensate trap installed on the same side of the cabinet require either a return air base or field-fabricated transition to accommodate an optional IAQ accessory taller than 14.2".

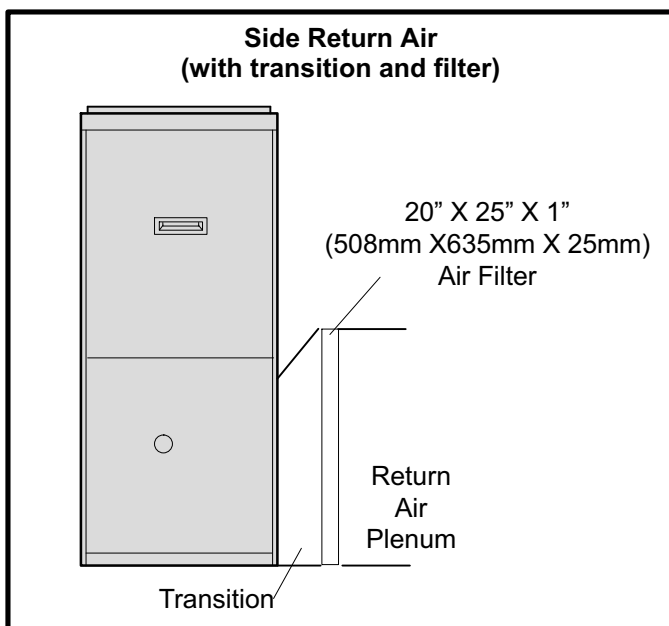

FIGURE 10

Removing the Bottom Panel

Remove the two screws that secure the bottom cap to the furnace. Pivot the bottom cap down to release the bottom panel. Once the bottom panel has been removed, reinstall the bottom cap. See figure 11.

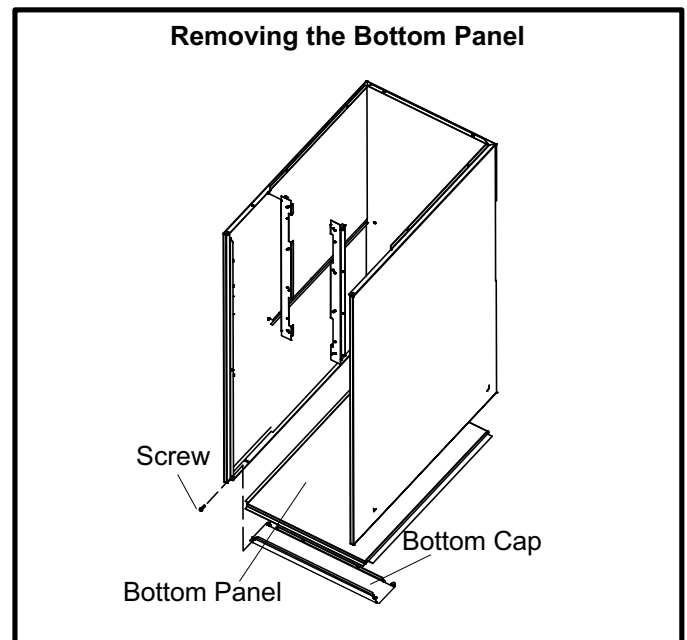

FIGURE 11

Setting an Upflow Unit

When the side return air inlets are used in an upflow application, it may be necessary to install leveling bolts on the bottom of the furnace. Use field-supplied corrosion-resistant 5/16 inch machine bolts (4) and nuts (8). See figure 12.

NOTE - The maximum length of the bolt is 1-1/2 inches.

- 1 - Lie the furnace on its back and drill a 5/16 inch diameter hole in each corner of the furnace's bottom. See figure 12 for the correct location of the holes. Drill through the bottom panel and the bottom flange of the cabinet.
- 2 - Install one bolt and two nuts into each hole. Screw the first nut onto a bolt and then insert the bolt into a hole. A flat washer may be added between the nut and the bottom of the unit.
- 3 - Screw another nut onto the bolt on the inside of the furnace base. A flat washer may be added between the nut and the bottom of the unit.
- 4 - Adjust the outside nut to the appropriate height and tighten the inside nut to secure the arrangement.

NOTE - The unit may be tilted back-to-front a maximum of 1". This will ensure proper draining of the heat exchanger.

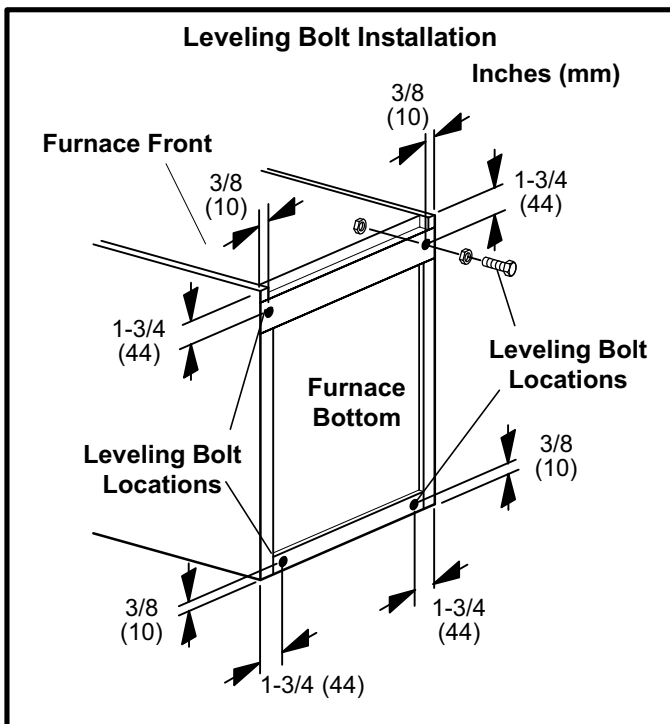

FIGURE 12

Downflow Applications

The unit may be installed three ways in downflow applications: on non-combustible flooring, on combustible flooring using an additive base, or on a reverse-flow cooling cabinet. **Do not drag the unit across the floor in the downflow position. Flange damage will result.**

After unit has been properly set in place, position provided logo over existing logo and affix sticker on front panel.

Refer to figure 13 for clearances in downflow applications.

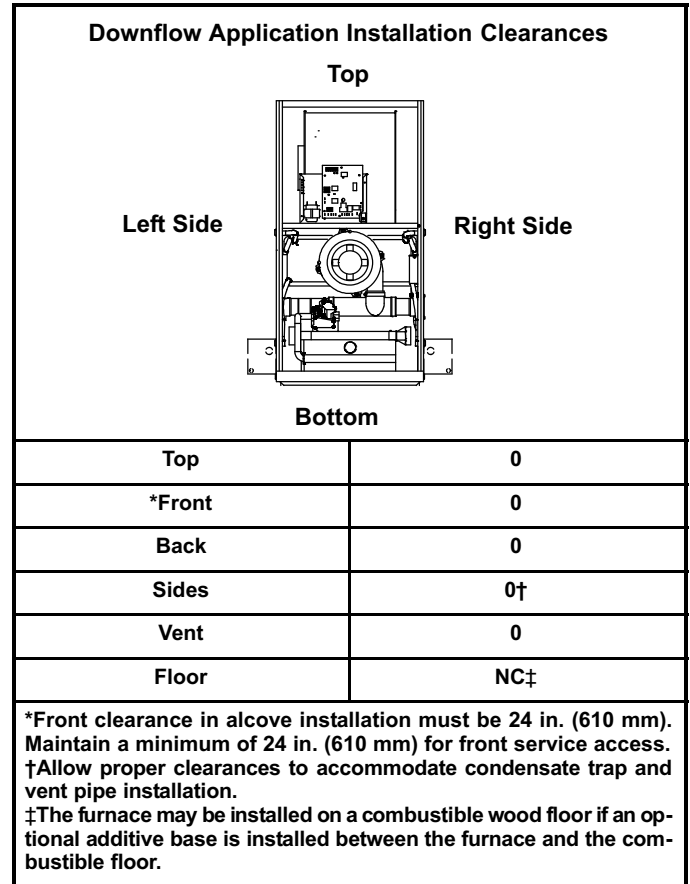

FIGURE 13

Installation on Non-Combustible Flooring

- 1 - Cut floor opening keeping in mind clearances listed on unit rating plate. Also keep in mind gas supply connections, electrical supply, flue and air intake connections and sufficient installation and servicing clearances. See table 1 for correct floor opening size.
- 2 - Flange warm air plenum and lower the plenum into the opening.
- 3 - Set the unit over the plenum and seal the plenum to the unit.
- 4 - Ensure that the seal is adequate.

TABLE 1
NON-COMBUSTIBLE FLOOR OPENING SIZE

Model No.	Front to Rear		Side to Side	
	in.	mm	in.	mm
B Cabinet (17.5")	19 - 3/4	502	16 - 5/8	422
C Cabinet (21")	19 - 3/4	502	20-1/8	511
D Cabinet (24.5")	19 - 3/4	502	23 - 5/8	600

NOTE - Floor opening dimensions listed are 1/4 inch (6 mm) larger than the unit opening. See dimension drawing on page 2.

Installation on Combustible Flooring (Using an Additive Base)

- 1 - When unit is installed on a combustible floor, an additive base must be installed between the furnace and the floor. The base must be ordered separately. See table 2 for opening size to cut in floor.

⚠ CAUTION

The furnace and additive base shall not be installed directly on carpeting, tile, or other combustible material other than wood flooring.

**TABLE 2
ADDITIVE BASE FLOOR OPENING SIZE**

Cabinet Width	Catalog Number	Front to Rear		Side to Side	
		in.	mm	in.	mm
B Cabinet (17.5")	11M60	22	559	18 - 3/4	476
C Cabinet (21")	11M61	22	559	22 - 3/4	578
D Cabinet (24.5")	11M62	22	559	25 - 3/4	654

- 2 - After opening is cut, set additive base into opening.
- 3 - Check fiberglass strips on additive base to make sure they are properly glued and positioned.
- 4 - Lower supply air plenum into additive base until plenum flanges seal against fiberglass strips.

NOTE - Be careful not to damage fiberglass strips. Check for a tight seal.

- 5 - Set the furnace over the plenum.
- 6 - Ensure that the seal between the furnace and plenum is adequate.

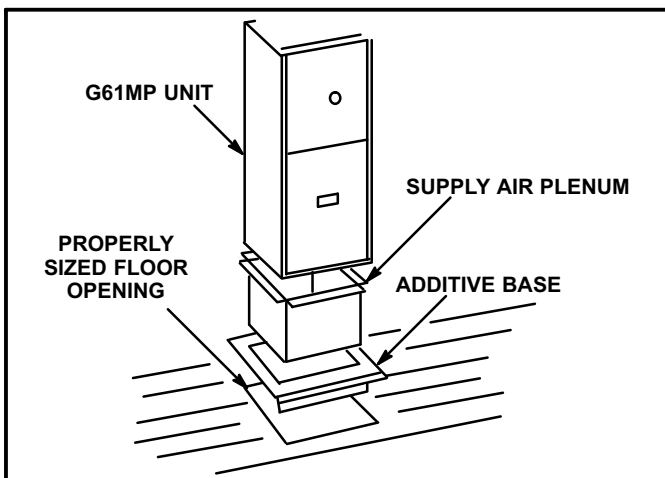

FIGURE 14

Installation on Cooling Coil Cabinet

- 1 - Refer to reverse-flow coil installation instructions for correctly sized opening in floor and installation of cabinet.
- 2 - When cooling cabinet is in place, set and secure the furnace according to the instructions that are provided with the cooling coil. Secure the furnace to the cabinet.
- 3 - Seal the cabinet and check for air leaks.

Return Air Opening -- Downflow Units

Return air may be brought in only through the top opening of a furnace installed in the downflow position. The following steps should be taken when installing plenum:

- 1 - Bottom edge of plenum should be flanged with a hemmed edge (See figure 15 or 16).
- 2 - Sealing strips should be used to ensure an airtight seal between the cabinet and the plenum.
- 3 - In all cases, plenum should be secured to top of furnace using sheet metal screws.
- 4 - Make certain that an adequate seal is made.

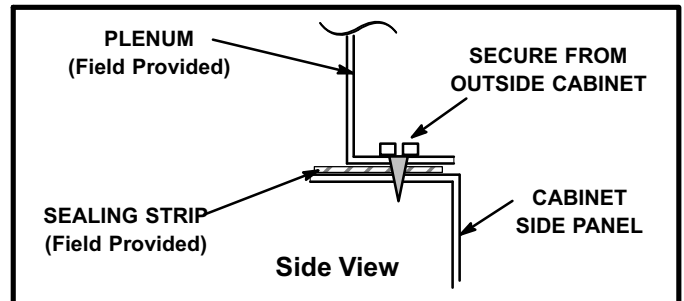

FIGURE 15

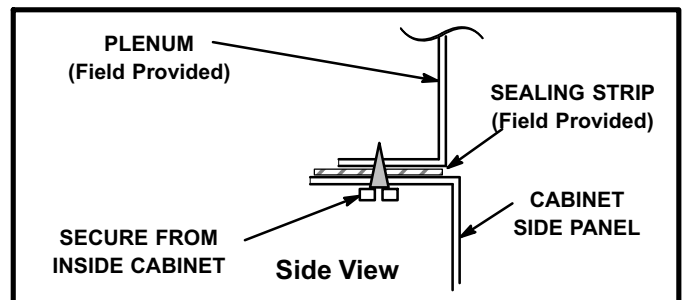

FIGURE 16

Horizontal Applications

The G61MP furnace can be installed in horizontal applications with either right- or left-hand air discharge.

The G61MP may also be installed as a unit heater. Either suspend the furnace as shown in figure 18, or install the furnace on a field-fabricated raised platform. The unit must be supported at both ends and beneath the blower deck to prevent sagging.

Refer to figure 17 for clearances in horizontal applications.

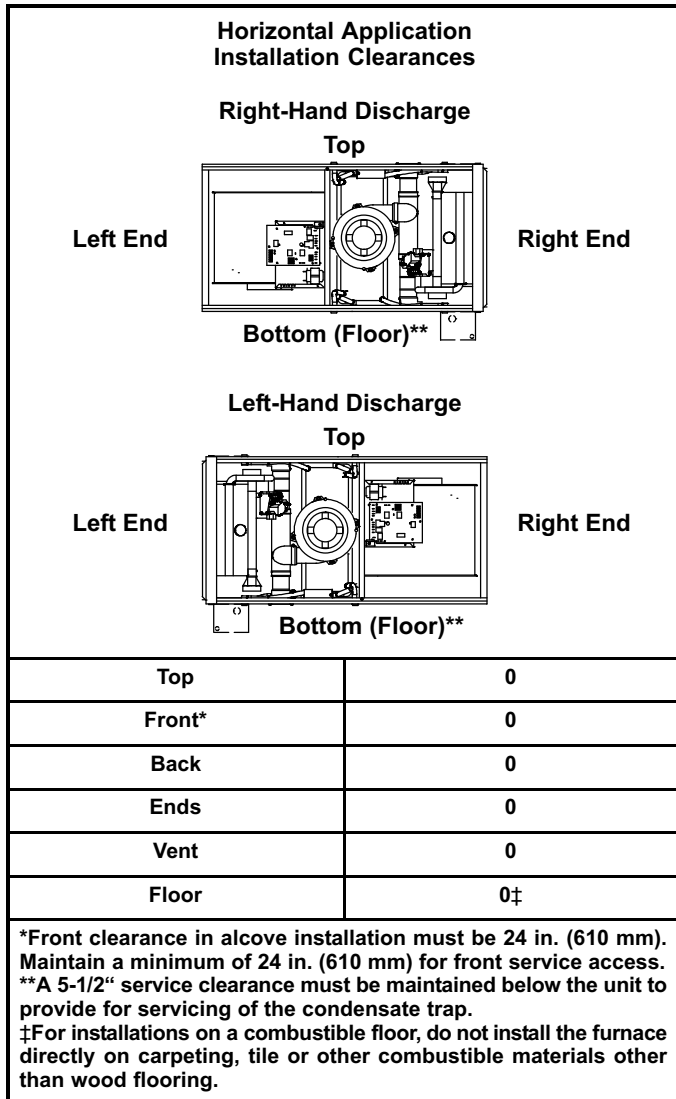

FIGURE 17

Suspended Installation of Horizontal Unit

NOTE - If unit is suspended in attic or crawl space, horizontal support kit (Cat No. 56J18 ordered separately) must be used to ensure proper unit support and coil drainage.

- 1 - Select location for unit keeping in mind service and other necessary clearances. See figure 17.
- 2 - Provide service platform in front of unit.

- 3 - If unit is installed above finished space, fabricate a drain pan fitted with a 1/2 inch or 3/4 inch N.P.T. fitting.
- 4 - Using 3/8 inch rods and support frame kit or field-fabricated supports, fabricate suspension hangers, keeping in mind front service access clearances.
- 5 - Mount unit on support frame as shown in figure 18.
- 6 - Continue with exhaust, condensate and intake line piping instructions.
- 7 - If unit is suspended above finished space, hang the field-provided drain pan below the support frame as shown in figure 18. Leave 5-1/2 inches for service clearance below unit for condensate trap.
- 8 - Route auxiliary drain line so that water draining from this outlet will be easily noticed by the homeowner. If necessary, run the condensate line into a condensate pump to meet drain line slope requirements. The pump must be rated for use with condensing furnaces. Protect the condensate discharge line from the pump to the outside to avoid freezing.

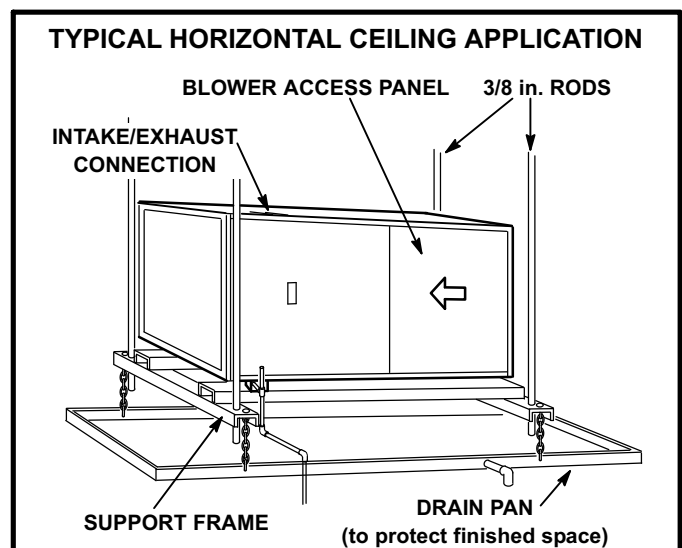

FIGURE 18

Platform Installation of Horizontal Unit

- 1 - Select location for unit keeping in mind service and other necessary clearances. See figure 17.
- 2 - Construct a raised wooden frame and cover frame with a plywood sheet. Provide a service platform in front of unit. If unit is installed above finished space, fabricate a drain pan to be installed under unit. When installing the unit in a crawl space, a proper support platform may be created using cement blocks and the horizontal support frame kit (ordered separately,

Lennox part number 56J18). Position the support frame on top of the blocks and install the unit on the frame. Leave 5-1/2 inches for service clearance for condensate trap.

- 3 - Route auxiliary drain line so that water draining from this outlet will be easily noticed by the homeowner. If necessary, run the condensate line into a condensate pump to meet drain line slope requirements. The pump must be rated for use with condensing furnaces. Protect the condensate discharge line from the pump to the outside to avoid freezing.
- 4 - Set unit in drain pan as shown in figure 19. Leave 5-1/2 inches for service clearance below unit for condensate trap.
- 5 - Continue with exhaust, condensate and intake piping installation according to instructions.

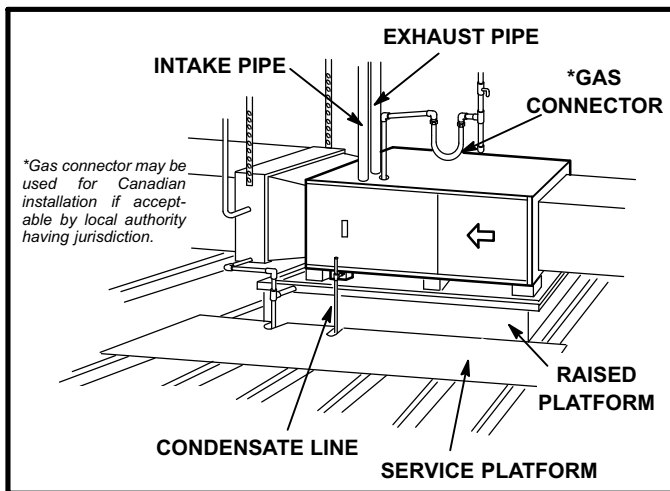

FIGURE 19

G61MP Installed in Unit Heater Applications

The G61MP may also be installed as a unit heater. Either suspend the furnace from roof rafters or floor joists, as shown in figure 18, or install the furnace on a field-fabricated raised platform, as shown in figure 19. The unit must be supported at both ends and beneath the blower deck to prevent sagging. The condensate trap must be installed where it can be serviced at a later date.

Unit Heater Discharge Duct Guidelines

A field-fabricated and installed discharge air duct and grille cabinet is suitable for use with the G61MP heater. Keep the following items in mind when constructing the cabinet.

- 1 - Outer dimensions of cabinet should match those of the unit heater, so the duct/grille cabinet installs flush with the unit heater cabinet. See figure 20.
- 2 - Flange both ends of duct/grille cabinet so that screws can be used to secure cabinet to discharge end of unit heater.
- 3 - To ensure proper operation, the duct/grille cabinet must be at least 18 inches long.
- 4 - Use #10-16 x 1/2 inch sheet metal screws to secure duct/grille cabinet to unit, taking care not to damage internal components of unit heater when drilling holes or installing screws. See figure 20.
- 5 - Use adjustable, double-deflection grille(s) to distribute discharge air. Adjust static pressure to be in the 0.06 inch to 0.10 inch w.c. range.

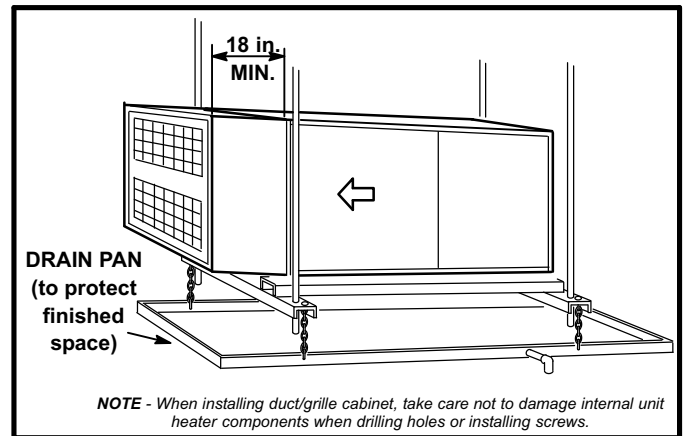

FIGURE 20

Return Air -- Horizontal Applications

Return air may be brought in only through the end of a furnace installed in the horizontal position. The furnace is equipped with a removable bottom panel to facilitate installation. See figure 11.

Filters

This unit is not equipped with a filter or rack. A field-provided filter is required for the unit to operate properly. Table 3 lists recommended filter sizes.

A filter must be in place whenever the unit is operating.

TABLE 3

Furnace Cabinet Width	Filter Size	
	Side Return	Bottom Return
17-1/2"	16 X 25 X 1 (1)	16 X 25 X 1 (1)
21"	16 X 25 X 1 (1)	20 X 25 X 1 (1)
24-1/2"	16 X 25 X 1 (2)	24 X 25 X 1 (1)

Duct System

Use industry-approved standards to size and install the supply and return air duct system. This will result in a quiet and low-static system that has uniform air distribution.

NOTE - Operation of this furnace in heating mode (indoor blower operating at selected heating speed) with an external static pressure which exceeds 0.5 inches w.c. may result in erratic limit operation.

Supply Air Plenum

If the furnace is installed without a cooling coil, a removable access panel should be installed in the supply air duct. The access panel should be large enough to permit inspection (by reflected light) of the heat exchanger for leaks after the furnace is installed. If present, this access panel must always be in place when the furnace is operating and it must not allow leaks into the supply air duct system.

Return Air Plenum

NOTE - Return air must not be drawn from a room where this furnace, or any other gas-fueled appliance (i.e., water heater), or carbon monoxide-producing device (i.e., wood fireplace) is installed.

When return air is drawn from a room, a negative pressure is created in the room. If a gas appliance is operating in a room with negative pressure, the flue products can be pulled back down the vent pipe and into the room. This reverse flow of the flue gas may result in incomplete combustion and the formation of carbon monoxide gas. This toxic gas might then be distributed throughout the house by the furnace duct system.

Return air can be brought in through the bottom or either side of the furnace. If a furnace with bottom return air is installed on a platform, make an airtight seal between the bottom of the furnace and the platform to ensure that the unit operates properly and safely. Use fiberglass sealing strips, caulking, or equivalent sealing method between the plenum and the furnace cabinet to ensure a tight seal. If a filter is installed, size the return air duct to fit the filter frame.

Pipe & Fittings Specifications

All pipe, fittings, primer and solvent cement must conform with American National Standard Institute and the American Society for Testing and Materials (ANSI/ASTM) standards. The solvent shall be free flowing and contain no lumps, undissolved particles or any foreign matter that adversely affects the joint strength or chemical resistance of the cement. The cement shall show no gelation, stratification, or separation that cannot be removed by stirring. Refer to the table 4 for approved piping and fitting materials.

⚠ CAUTION

Solvent cements for plastic pipe are flammable liquids and should be kept away from all sources of ignition. Do not use excessive amounts of solvent cement when making joints. Good ventilation should be maintained to reduce fire hazard and to minimize breathing of solvent vapors. Avoid contact of cement with skin and eyes.

**TABLE 4
PIPING AND FITTINGS SPECIFICATIONS**

PIPE & FITTING MATERIAL	ASTM SPECIFICATION
Schedule 40 PVC (Pipe)	D1785
Schedule 40 PVC (Cellular Core Pipe)	F891
Schedule 40 PVC (Fittings)	D2466
Schedule 40 CPVC (Pipe)	F441
Schedule 40 CPVC (Fittings)	F438
SDR-21 PVC or SDR-26 PVC (Pipe)	D2241
SDR-21 CPVC or SDR-26 CPVC (Pipe)	F442
Schedule 40 ABS Cellular Core DWV (Pipe)	F628
Schedule 40 ABS (Pipe)	D1527
Schedule 40 ABS (Fittings)	D2468
ABS-DWV (Drain Waste & Vent) (Pipe & Fittings)	D2661
PVC-DWV (Drain Waste & Vent) (Pipe & Fittings)	D2665
PRIMER & SOLVENT CEMENT	ASTM SPECIFICATION
PVC & CPVC Primer	F656
PVC Solvent Cement	D2564
CPVC Solvent Cement	F493
ABS Solvent Cement	D2235
PVC/CPVC/ABS All Purpose Cement For Fittings & Pipe of the same material	D2564, D2235, F493
ABS to PVC or CPVC Transition Solvent Cement	D3138
CANADA PIPE & FITTING & SOLVENT CEMENT	MARKING
PVC & CPVC Pipe and Fittings	ULCS636
PVC & CPVC Solvent Cement	
ABS to PVC or CPVC Transition Cement	

Use PVC primer and solvent cement or ABS solvent cement meeting ASTM specifications, refer to Table 4. As an alternate, use all purpose cement, to bond ABS, PVC, or CPVC pipe when using fittings and pipe made of the same materials. Use transition solvent cement when bonding ABS to either PVC or CPVC.

Low temperature solvent cement is recommended. Metal or plastic strapping may be used for vent pipe hangers. Uniformly apply a liberal coat of PVC primer for PVC or use a clean dry cloth for ABS to clean inside socket surface of fitting and male end of pipe to depth of fitting socket.

Canadian Applications Only - Pipe, fittings, primer and solvent cement used to vent (exhaust) this appliance must be certified to ULC S636 and supplied by a single manufacturer as part of an approved vent (exhaust) system. When bonding the vent system to the furnace, use ULC S636 approved One-Step Transition Cement to bond the pipe to the flue collar, or to bond the 90° elbow or reducing 90° elbow to the flue collar. In addition, the first three feet of vent pipe from the furnace flue collar must be accessible for inspection.

Table 5 lists the available exhaust termination kits, as well as vent pipe equivalencies which must be used when sizing vent pipe. All Lennox vent terminations are PVC.

**TABLE 5
OUTDOOR TERMINATION KITS AND CORRESPONDING EQUIVALENCIES**

UNIT MODEL	VENT PIPE DIA. (in.)	Vent Pipe Length Equivalency (feet)							
		Outdoor Exhaust Accelerator (Dia. X Length)	Outdoor Exhaust Accelerator (Dia. X Length)	1-1/2" Concentric Kit	2" Con-centric Kit	3" Con-centric Kit	2" Wall Plate Kit	3" Wall Plate Kit	2" Wall Ring Kit
		1-1/2" X 12"	2" X 12"	71M80 or 44W92†	69M29 or 44W92†	60L46 or 44W93†	22G44 or 30G28†	44J40 or 81J20†	15F74
36B-045	2	4	Not Allowed	12	Not Allowed	Not Allowed	4	4*	4
	2-1/2	5	Not Allowed	15	Not Allowed	Not Allowed	5	5*	5
	3	7	Not Allowed	21	Not Allowed	Not Allowed	7	7*	7
	4	14	Not Allowed	42	Not Allowed	Not Allowed	14	14*	14
36B-070 36B-071	2	4	Not Allowed	12	Not Allowed	Not Allowed	4	4*	4
	2-1/2	5	Not Allowed	15	Not Allowed	Not Allowed	5	5*	5
	3	8	Not Allowed	24	Not Allowed	Not Allowed	8	8*	8
	4	14	Not Allowed	42	Not Allowed	Not Allowed	14	14*	14
48C-090 60C-090 60C-091	2	Not Allowed	1	Not Allowed	3	3	Not Allowed	1	1**
	2-1/2	Not Allowed	2	Not Allowed	6	6	Not Allowed	2	2**
	3	Not Allowed	2	Not Allowed	6	6	Not Allowed	2	2**
	4	Not Allowed	4	Not Allowed	12	12	Not Allowed	4	4**
48C-110 60C-110 60C-111	2-1/2	Not Allowed	2	Not Allowed	6	6	Not Allowed	2	2
	3	Not Allowed	2	Not Allowed	6	6	Not Allowed	2	2
	4	Not Allowed	4	Not Allowed	12	12	Not Allowed	4	4
60D-135	3	Not Allowed	6	Not Allowed	Not Allowed	15	Not Allowed	6	Not Allowed
	4	Not Allowed	10	Not Allowed	Not Allowed	25	Not Allowed	10	Not Allowed

*Requires field-provided and installed 1-1/2" exhaust accelerator.

**Requires field-provided and installed 2" exhaust accelerator.

† Termination kits 44W92 (includes 1-1/2" reducer), 44W93, 30G28 and 81J20 approved for use in Canadian installations.

Vent Piping Guidelines

The G61MP can be installed as either a **Non-Direct Vent** or a **Direct Vent** gas central furnace.

NOTE - In *Non-Direct Vent* installations, combustion air is taken from indoors and flue gases are discharged outdoors. In *Direct Vent* installations, combustion air is taken from outdoors and flue gases are discharged outdoors.

Intake and exhaust pipe sizing in Direct Vent applications and exhaust pipe sizing in Non-Direct Vent applications -- Size pipe according to tables 6 and 7. Table 6 lists the *minimum* equivalent vent pipe lengths permitted. Table 7 lists the *maximum* equivalent pipe lengths permitted.

Maximum vent length is defined as:

Total length (linear feet) of pipe,
Plus Equivalent length (feet) of fittings,
Plus Equivalent length (feet) of termination.

NOTE - **Include ALL pipe and ALL fittings, both in doors and outdoors.**

Regardless of the diameter of pipe used, the standard roof and wall terminations described in section *Exhaust Piping Terminations* should be used. Exhaust vent termination pipe is sized to optimize the velocity of the exhaust gas as it exits the termination. Refer to table 8.

***NOTE** - The exhaust pipe should be offset a minimum of 12 inches to avoid the possibility of water droplets being re-

leased from the exhaust termination. The minimum exhaust vent length is 15 ft. Shorter exhaust vent lengths may result in the discharge of water droplets from the exhaust termination, in spite of the 12-inch vertical offset. See figure 21.

Each 90° elbow (including those provided with the furnace) of any diameter is equivalent to 5 feet (1.52m) of vent pipe of the same diameter. Two 45° elbows are equivalent to one 90° elbow of the same diameter. One 45° elbow is equal to 2.5 feet (.76m) of vent pipe of the same diameter. In some applications which permit the use of several different sizes of vent pipe, a combination vent pipe may be used. Contact the Application Department for assistance in sizing vent pipe in these applications.

NOTE - The flue collar on all models is sized to accommodate 2" Schedule 40 flue pipe. When vent pipe which is larger than 2" must be used in an upflow application, a 2" elbow must be applied at the flue collar in order to properly transition to the larger diameter flue pipe. This elbow must be added to the elbow count used to determine acceptable vent lengths. Assign an equivalent feet value to this elbow according to the larger size pipe being used. Contact Lennox' Application Department for more information concerning sizing of vent systems which include multiple pipe sizes.

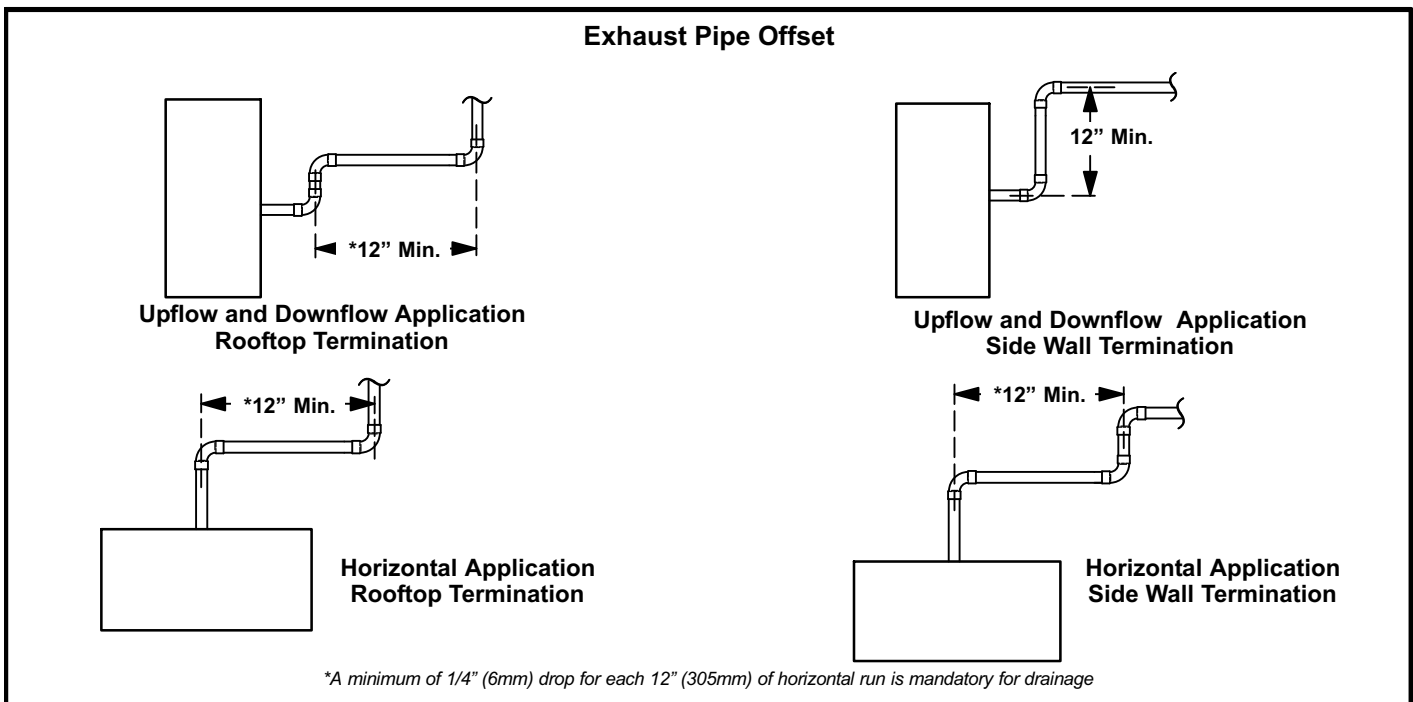

FIGURE 21

Use the following steps to correctly size vent pipe diameter. Refer to Vent Pipe Size Determination Worksheet on page 53.

- 1 - Determine the vent termination and its corresponding equivalent feet value according to table 5.
- 2 - Determine the number of 90° elbows required for both indoor and outdoor (e.g. snow riser) use. Calculate the corresponding equivalent feet of vent pipe.
- 3 - Determine the number of 45° elbows required for both indoor and outdoor use. Calculate the corresponding equivalent feet of vent pipe.
- 4 - Determine the length of straight pipe required.
- 5 - Add the total equivalent feet calculated in steps 1 through 4 and compare that length to the maximum values given in table 6 for the proposed vent pipe diameter. If the total equivalent length required exceeds the maximum equivalent length listed in the appropriate table, evaluate the next larger size pipe.

**TABLE 6
MINIMUM VENT PIPE LENGTHS**

G61MP MODEL	MIN. EQUIV. VENT LENGTH	EXAMPLE
045, 070, 071, 090, 091	15 ft.*	5 ft. plus 2 elbows of 2", 2-1/2", 3" or 4" diameter pipe
110, 111**		5 ft. plus 2 elbows of 2-1/2" 3" or 4" diameter pipe
135***		5 ft. plus 2 elbows of 3" or 4" diameter pipe

*Any approved termination may be added to the minimum equivalent length listed.

**G61MP-48C-110, G61MP-60C-110 and G61MP-60C-111 must have 90° street ell (supplied or field replacement Canadian kit) installed directly into unit flue collar.

***G61MP-60D-135 must have 3" to 2" reducing ell (supplied or field replacement Canadian kit) installed directly into unit flue collar.

**TABLE 7
MAXIMUM VENT PIPE LENGTHS**

ALTITUDE	G61MP MODEL	MAXIMUM EQUIVALENT VENT LENGTH FEET			
		2" PIPE	2-1/2" PIPE	3" PIPE	4" PIPE
0 - 4500 (0 - 1371 m)	045	59	65	77	234
	070	59	65	78	214
	071†	59	65	78	214
	090	26	42	72	204
	091†	26	42	72	204
	110*	n/a	32	72	179
	111*†	n/a	32	72	179
4501-7500 (1372-2286 m)	135**‡	n/a	n/a	61	160
	045	59	65	77	234
	070	59	65	78	214
	071†	59	65	78	214
	090	26	42	72	204
	091†	26	42	72	204
	110*	n/a	32	72	179
7501 - 10000 (2287 - 3048 m)	111*†	n/a	32	72	179
	135**‡	n/a	n/a	46	160
	045	59	65	77	234
	070	59	65	78	214
	071†	59	65	78	214
	090	26	42	72	204
	091†	26	42	72	204
	110*	n/a	32	72	179
	111*†	n/a	32	72	179
	135**‡	n/a	n/a	46	160

n/a -- Not allowed.

*G61MP-48C-110, G61MP-60C-110 and G61MP-60C-111 must have 90° street ell (supplied or field replacement Canadian kit) installed directly into unit flue collar.

**G61MP-60D-135 must have 3" to 2" reducing ell (supplied or field replacement Canadian kit) installed directly into unit flue collar.

***90° elbows used in configuration of G61MP-60D-135 vent, must be limited to 3" sweep elbows.

†On G61MP-071, -091 and -111 units, sweep elbows must be used for all 90° elbows in the venting system when 2", 2-1/2" or 3" vent pipe is used. Sweep elbows are recommended for use in vent systems of other G61MP units.

Joint Cementing Procedure

All cementing of joints should be done according to the specifications outlined in ASTM D 2855.

WARNING

DANGER OF EXPLOSION!

Fumes from PVC glue may ignite during system check. Allow fumes to dissipate for at least 5 minutes before placing unit into operation.

- 1 - Measure and cut vent pipe to desired length.
- 2 - Debur and chamfer end of pipe, removing any ridges or rough edges. If end is not chamfered, edge of pipe may remove cement from fitting socket and result in a leaking joint.
- 3 - Clean and dry surfaces to be joined.
- 4 - Test fit joint and mark depth of fitting on outside of pipe.
- 5 - Uniformly apply a liberal coat of PVC primer for PVC or use a clean dry cloth for ABS to clean inside socket surface of fitting and male end of pipe to depth of fitting socket.

NOTE - Furnace flue collar and air inlet fitting are both made of ABS material. Use transition solvent cement when bonding ABS to either PVC or CPVC, refer to the procedure specified in ASTM D3138..

- 6 - Promptly apply solvent cement to end of pipe and inside socket surface of fitting. Cement should be applied lightly but uniformly to inside of socket. Take care to keep excess cement out of socket. Apply second coat to end of pipe.

NOTE - Time is critical at this stage. Do not allow primer to dry before applying cement.

- 7 - Immediately after applying last coat of cement to pipe, and while both inside socket surface and end of pipe are wet with cement, forcefully insert end of pipe into socket until it bottoms out. Turn PVC pipe 1/4 turn during assembly (but not after pipe is fully inserted) to distribute cement evenly. DO NOT turn ABS or cellular core pipe.

NOTE - Assembly should be completed within 20 seconds after last application of cement. Hammer blows should not be used when inserting pipe.

- 8 - After assembly, wipe excess cement from pipe at end of fitting socket. A properly made joint will show a bead around its entire perimeter. Any gaps may indicate a defective assembly due to insufficient solvent.
- 9 - Handle joints carefully until completely set.

Venting Practices

The thickness of construction through which vent pipes may be installed is 24" (610mm) maximum and 3" (76mm) minimum. If a G61MP furnace replaces a furnace which was commonly vented with another gas appliance, the size of the existing vent pipe for that gas appliance must be checked. Without the heat of the original furnace flue products, the existing vent pipe is probably oversized for the single water heater or other appliance. The vent should be checked for proper draw with the remaining appliance.

- 1 - Use recommended piping materials for exhaust piping.
- 2 - Secure all joints so that they are gas-tight using approved cement.

Suspend piping using hangers at a minimum of every 5 feet (1.52m) for schedule 40 PVC and every 3 feet (.91m) for ABS-DWV, PVC-DWV, SPR-21 PVC, and SDR-26 PVC piping. A suitable hanger can be fabricated by using metal or plastic strapping or a large wire tie.

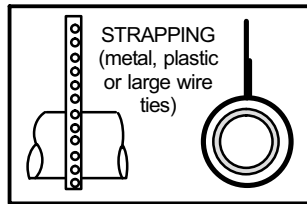

FIGURE 22

- 3 - In areas where piping penetrates joists or interior walls, hole must be large enough to allow clearance on all sides of pipe through center of hole using a hanger.

- 4 - Isolate piping at the point where it exits the outside wall or roof in order to prevent transmission of vibration to the structure.

- 5 - When furnace is installed in a residence where unit is shut down for an extended period of time, such as a vacation home, make provisions for draining condensate collection trap and lines.

Exhaust Piping

NOTE - A 2" diameter PVC street ell is located on the blower deck of 48C-110, 60C-110 and 60C-111 units. **In upflow or downflow applications the street ell must be glued using transition solvent cement directly into the unit flue collar.** See figure 23. A 3" to 2" PVC reducing ell is located on the blower deck of the 60D-135 units. **In upflow or downflow applications, the reducing ell must be glued using transition solvent cement directly into the unit flue collar.**

- 1 - Choose the appropriate side for venting in upflow or downflow positions. Exhaust piping exits from the top of the unit in horizontal air discharge applications. Glue the field-provided exhaust vent pipe (or provided street ell or reducing ell in upflow or downflow applications) to the flue collar. All PVC cement joints should be made according to the specifications outlined in ASTM D 2855. Refer to pipe and fittings specifications and gluing procedures.

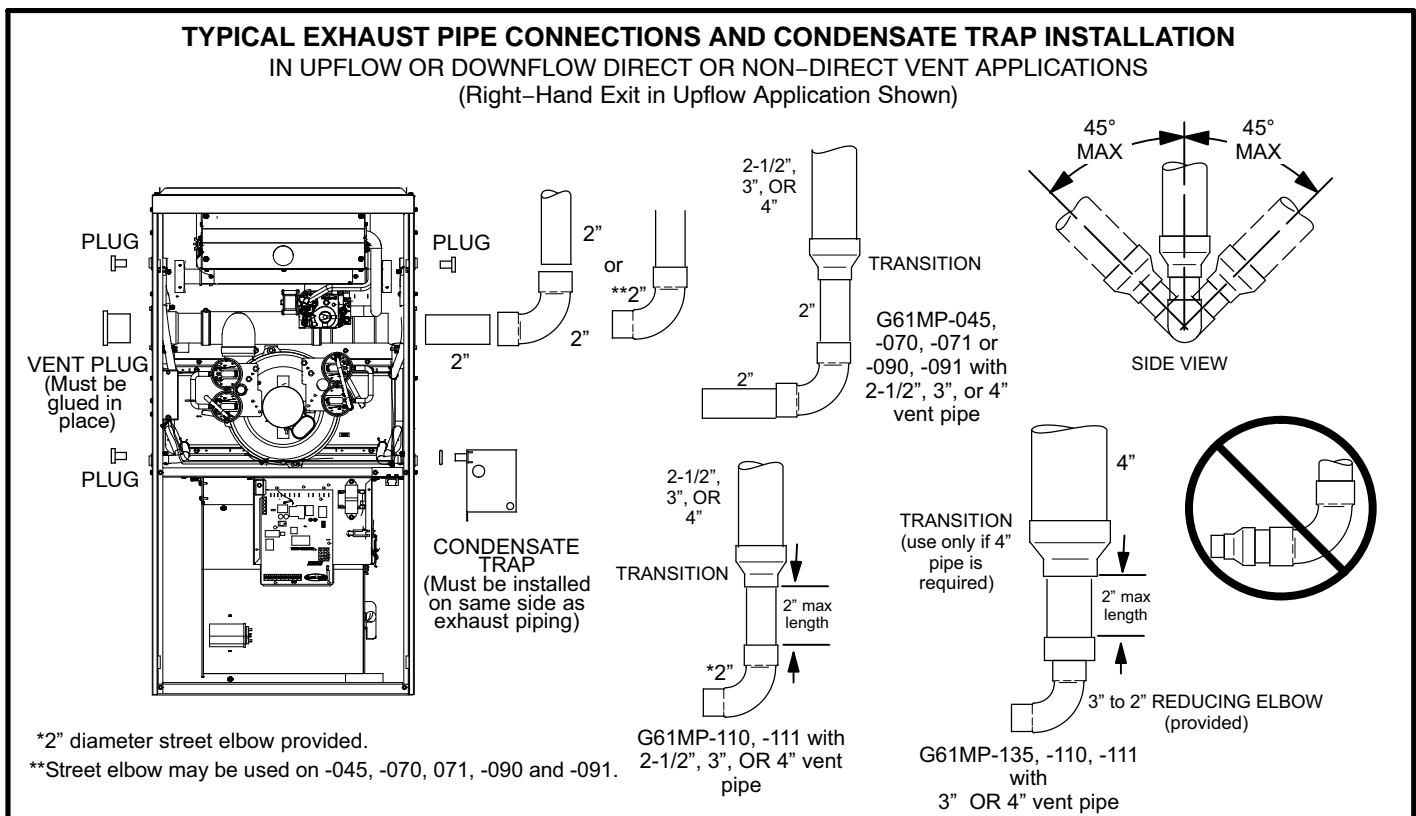
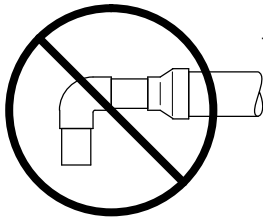

FIGURE 23

TYPICAL EXHAUST PIPE CONNECTIONS
HORIZONTAL DIRECT OR NON-DIRECT VENT
APPLICATIONS
 (Horizontal Right-Hand Air
 Discharge Application Shown)

* 2" maximum length
 for -110, -111 -135 only



DO NOT transition
from smaller to larger
pipe size in horizontal
runs of exhaust pipe.

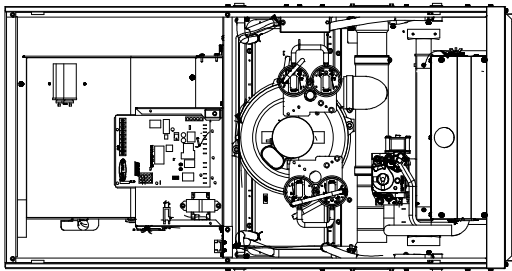
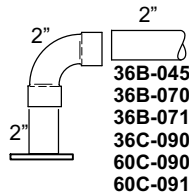
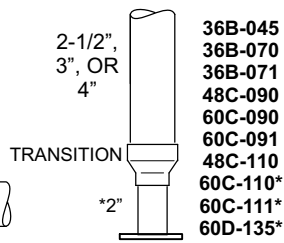

FIGURE 24

⚠ IMPORTANT

Exhaust piping and condensate trap must be installed on the same side of the unit in upflow and dowflow applications or use alternate drain kit 76M20.

- 2 - All horizontal runs of exhaust pipe must slope back toward unit. A minimum of 1/4" (6mm) drop for each 12" (305mm) of horizontal run is mandatory for drainage. Horizontal runs of exhaust piping must be supported every 5 feet (1.52m) using hangers.

NOTE - Exhaust piping should be checked carefully to make sure there are no sags or low spots.

- 3 - On the opposite side of the cabinet, glue the provided 2" ABS vent plug into the unused ABS flue collar with ABS or all purpose solvent cement.
- 4 - Route piping to outside of structure. Continue with installation following instructions given in piping termination section.

⚠ CAUTION

Do not discharge exhaust into an existing stack or stack that also serves another gas appliance. If vertical discharge through an existing unused stack is required, insert PVC pipe inside the stack until the end is even with the top or outlet end of the metal stack.

⚠ CAUTION

The exhaust vent pipe operates under positive pressure and must be completely sealed to prevent leakage of combustion products into the living space.

Intake Piping

The G61MP furnace may be installed in either **direct vent** or **non-direct vent** applications. In non-direct vent applications, when intake air will be drawn into the furnace from the surrounding space, the indoor air quality must be considered and guidelines listed in Combustion, Dilution and Ventilation Air section must be followed.

The G61MP unit is designed for either left-side or right-side air intake connections in either upflow or downflow applications. In horizontal applications, air intake must be brought in through the top. Intake air piping is independent of exhaust piping.

Follow the next four steps when installing the unit in **direct vent applications**, where combustion air is taken from outdoors and flue gases are discharged outdoors. **The provided air intake screen must not be used in direct vent applications.**

- 1 - Use transition solvent cement to connect PVC pipe to the ABS slip connector located on the side of the burner box.
- 2 - Use a #7 sheet metal screw to secure the intake pipe to the connector, if desired. A pilot indentation is provided in the slip connector to assist in locating and starting the fastener.
- 3 - Glue the provided 2" ABS plug into the unused ABS air intake connector on the opposite side of the cabinet with ABS all purpose cement.
- 4 - Route piping to outside of structure. Continue with installation following instructions given in general guide lines for piping terminations and in intake and exhaust piping terminations for direct vent sections. Refer to figure 25 for pipe sizes.

TYPICAL AIR INTAKE PIPE CONNECTIONS
UPFLOW OR DOWNFLOW DIRECT VENT APPLICATIONS
(Right-Hand Exit in Upflow Application Shown)

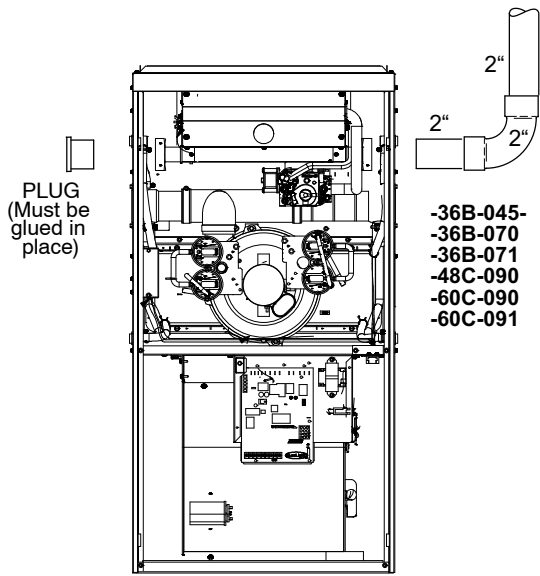

- 36B-045-
- 36B-070
- 36B-071
- 48C-090
- 60C-090
- 60C-091

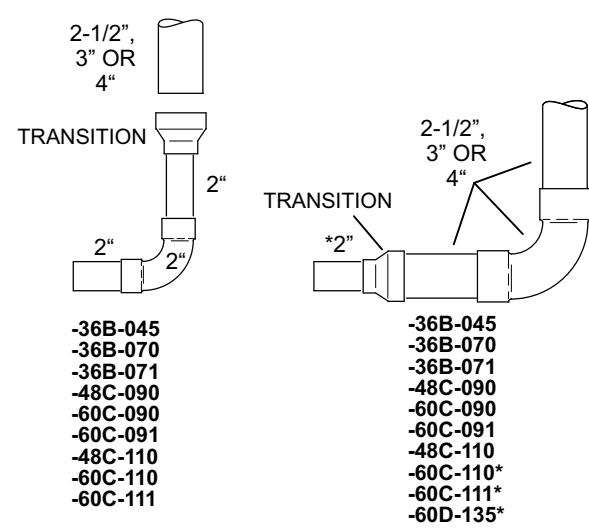

- 36B-045
- 36B-070
- 36B-071
- 48C-090
- 60C-090
- 60C-091
- 48C-110
- 60C-110
- 60C-111

- 36B-045
- 36B-070
- 36B-071
- 48C-090
- 60C-090
- 60C-091
- 60C-110
- 48C-110*
- 60C-111*
- 60D-135*

*Limit pipe length to 4" in G61MP-110, -111, -135 applications.

FIGURE 25

TYPICAL AIR INTAKE PIPE CONNECTIONS
HORIZONTAL DIRECT VENT APPLICATIONS
(Horizontal Right-Hand Air Discharge Application Shown)

*Limit pipe length to 4" in -110, -111, -135 applications.

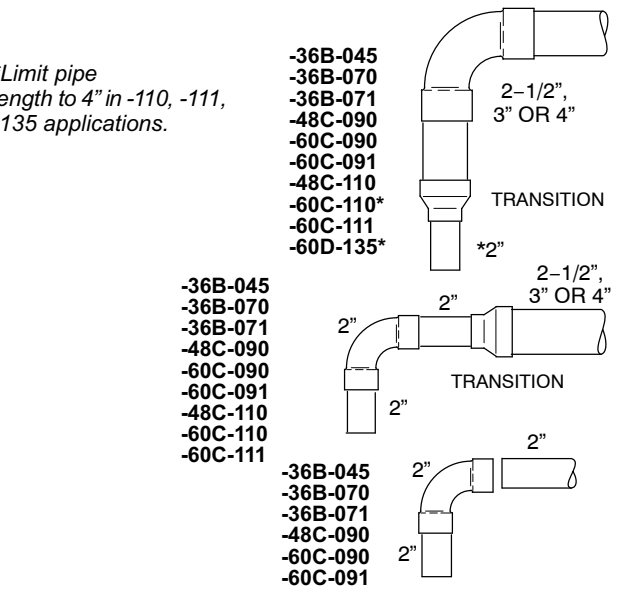

- 36B-045
- 36B-070
- 36B-071
- 48C-090
- 60C-090
- 60C-091
- 48C-110
- 60C-110*
- 60C-111
- 60D-135*

- 36B-045
- 36B-070
- 36B-071
- 48C-090
- 60C-090
- 60C-091
- 48C-110
- 60C-110
- 60C-111

- 36B-045
- 36B-070
- 36B-071
- 48C-090
- 60C-090
- 60C-091

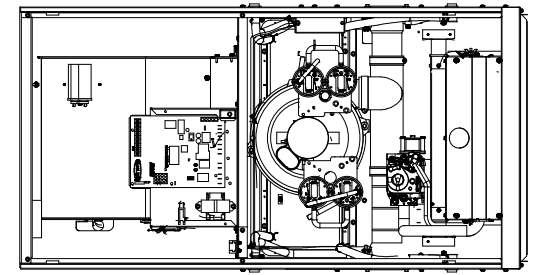
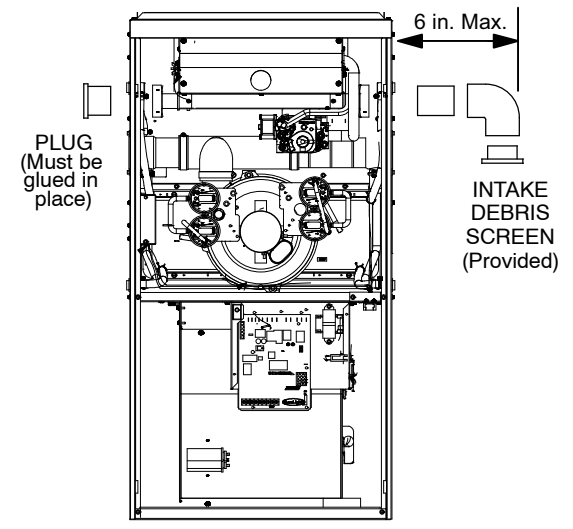

FIGURE 26

Follow the next three steps when installing the unit in **Non-Direct Vent applications** where combustion air is taken from indoors and flue gases are discharged outdoors.

TYPICAL AIR INTAKE PIPE CONNECTIONS
UPFLOW OR HORIZONTAL NON-DIRECT VENT APPLICATIONS
(Right-Hand Exit in Upflow Application Shown)



NOTE - Debris screen and elbow may be rotated, so that screen may be positioned to face forward, backward or downward.

FIGURE 27

TYPICAL AIR INTAKE PIPE CONNECTIONS
DOWNFLOW NON-DIRECT VENT APPLICATIONS
 (Right-Hand Exit in Downflow Applications Shown)

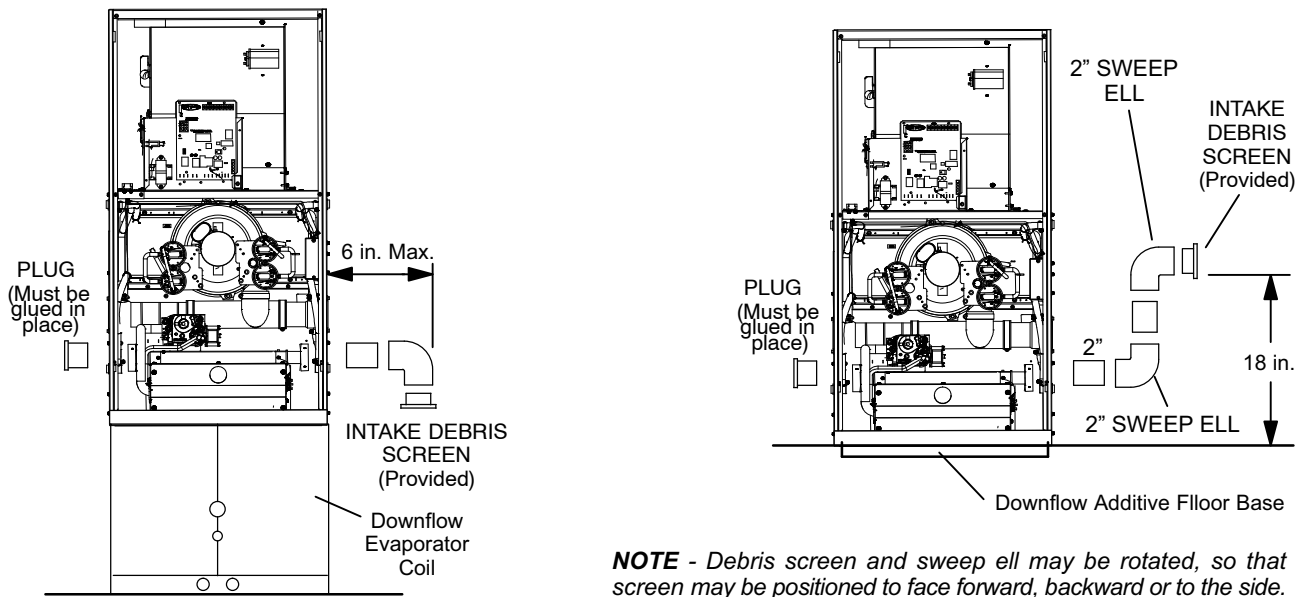

NOTE - Debris screen and sweep ell may be rotated, so that screen may be positioned to face forward, backward or to the side.

FIGURE 28

1 - Use field-provided materials and the factory-provided air intake screen to route the intake piping as shown in figures 27 and 28. Maintain a minimum clearance of 3" (76mm) around the air intake opening. The air intake opening (with the protective screen) should always be directed either downward or straight out. Use 2" pipe and fittings only and make sure that the air intake does not extend more than 6" beyond the G61MP cabinet. **The air intake connector must not be located near the floor. To avoid this complication in downflow applications which do not include a downflow**

evaporator coil, the intake air routing should be modified as shown in figure 28.

- 2 - Use a #7 sheet metal screw to secure the intake pipe to the connector, if desired. A pilot indentation is provided in the slip connector to assist in locating and starting the fastener.
- 3 - Glue the provided 2" ABS plug into the unused ABS air intake connector on the opposite side of the cabinet with ABS or all purpose solvent cement.

General Guidelines for Vent Terminations

In Non-Direct Vent applications, combustion air is taken from indoors and the flue gases are discharged to the outdoors. The G61MP is then classified as a non-direct vent, Category IV gas furnace.

In Direct Vent applications, combustion air is taken from outdoors and the flue gases are discharged to the outdoors. The G61MP is then classified as a direct vent, Category IV gas furnace.

In both Non-Direct Vent and Direct Vent applications, the vent termination is limited by local building codes. In the absence of local codes, refer to the current National Fuel Gas Code ANSI Z223-1/NFPA 54 in U.S.A., and current CSA-B149 Natural Gas and Propane Installation Codes in Canada for details.

Position termination according to location given in figure 29 or 30. In addition, position termination so it is free from any obstructions and 12" above the average snow accumulation.

At vent termination, care must be taken to maintain protective coatings over building materials (prolonged exposure to exhaust condensate can destroy protective coatings). It is recommended that the exhaust outlet not be located within 6 feet (1.8m) of a condensing unit because the condensate can damage the painted coating.

NOTE - If winter design temperature is below 32°F (0°C), exhaust piping should be insulated with 1/2" (13mm), Armaflex or equivalent when run through unheated space. Do not leave any surface area of exhaust pipe open to outside air; exterior exhaust pipe should be insulated with 1/2"

(13mm) Armaflex or equivalent. In extreme cold climate areas, 3/4" (19mm) Armaflex or equivalent may be necessary. Insulation on outside runs of exhaust pipe must be painted or wrapped to protect insulation from deterioration. Exhaust pipe insulation may not be necessary in some specific applications.

NOTE - During extremely cold temperatures, below approximately 20°F (6.7°C), units with long runs of vent pipe through unconditioned space, even when insulated, may form ice in the exhaust termination that prevents the unit from operating properly. Longer run times of at least 5 minutes will alleviate most icing problems. Also, a heating cable may be installed on exhaust piping and termination to prevent freeze-ups. Heating cable installation kit is available from Lennox. See Condensate Piping section for part numbers.

IMPORTANT

Do not use screens or perforated metal in exhaust terminations. Doing so will cause freeze-ups and may block the terminations.

IMPORTANT

For Canadian Installations Only:
In accordance to CSA International B149 installation codes, the minimum allowed distance between the combustion air intake inlet and the exhaust outlet of other appliances shall not be less than 12 inches (305mm).

VENT TERMINATION CLEARANCES FOR NON-DIRECT VENT INSTALLATIONS IN THE USA AND CANADA

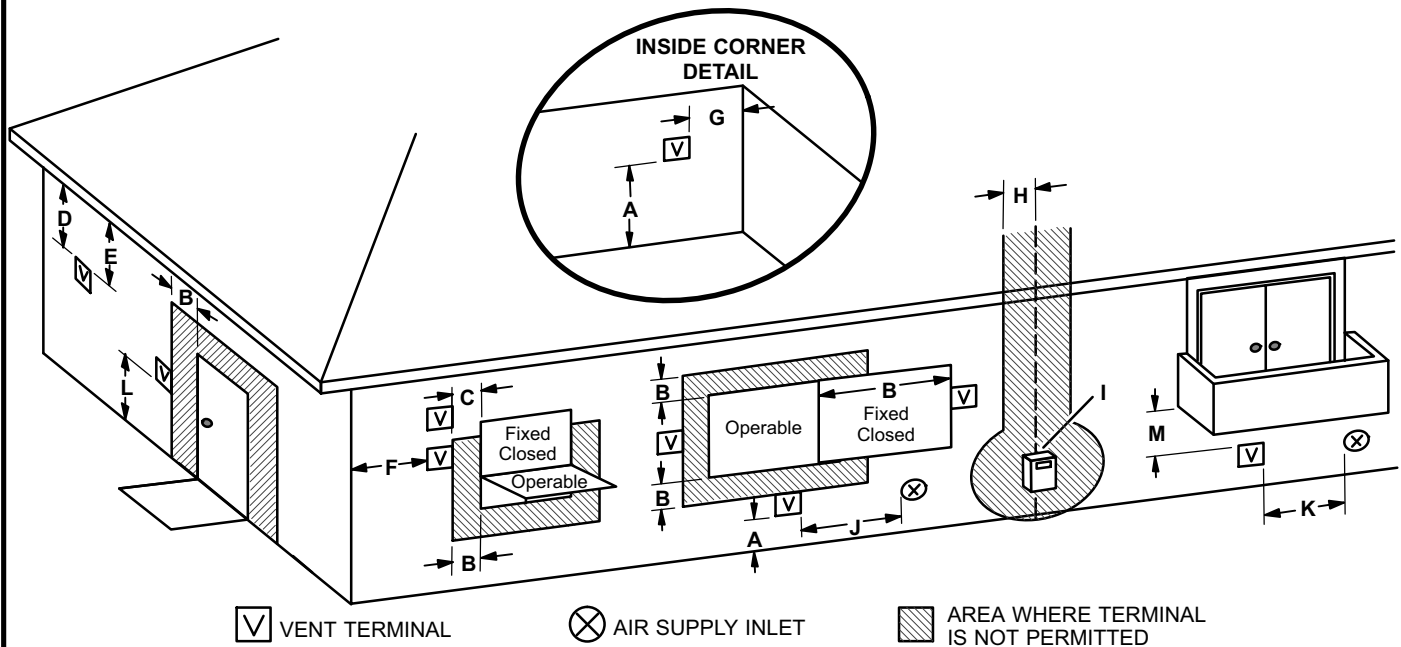

	US Installations ¹	Canadian Installations ²	
A =	Clearance above grade, veranda, porch, deck or balcony	12 inches (305mm) or 12 in. 305mm) above average snow accumulation.	12 inches (305mm) or 12 in. 305mm) above average snow accumulation.
B =	Clearance to window or door that may be opened	4 feet (1.2 m) below or to side of opening; 1 foot (30 cm) above opening	6 inches (152mm) for appliances <10,000 Btuh (3kw), 12 inches (305mm) for appliances > 10,000 Btuh (3kw) and <100,000 Btuh (30kw), 36 inches (.9m) for appliances > 100,000 Btuh (30kw)
C =	Clearance to permanently closed window	* 12"	* 12"
D =	Vertical clearance to ventilated soffit located above the terminal within a horizontal distance of 2 feet (mm) from the center line of the terminal	* Equal to or greater than soffit depth.	* Equal to or greater than soffit depth.
E =	Clearance to unventilated soffit	* Equal to or greater than soffit depth.	* Equal to or greater than soffit depth.
F =	Clearance to outside corner	* No minimum to outside corner	* No minimum to outside corner
G =	Clearance to inside corner	* 3 feet (.9m)	* 3 feet (.9m)
H =	Clearance to each side of center line extended above meter / regulator assembly	* 3 feet (.9m) within a height 15 feet (4.5m) above the meter / regulator assembly	3 feet (.9m) within a height 15 feet (4.5m) above the meter / regulator assembly
I =	Clearance to service regulator vent outlet	* 3 feet (.9m)	3 feet (.9m)
J =	Clearance to non-mechanical air supply inlet to building or the combustion air inlet to any other appliance	4 feet (1.2 m) below or to side of opening; 1 foot (30 cm) above opening	6 inches (152mm) for appliances <10,000 Btuh (3kw), 12 inches (305mm) for appliances > 10,000 Btuh (3kw) and <100,000 Btuh (30kw), 36 inches (.9m) for appliances > 100,000 Btuh (30kw)
K =	Clearance to mechanical air supply inlet	3 feet (.9m) above if within 10 feet (3m) horizontally	6 feet (1.8m)
L =	Clearance above paved sidewalk or paved driveway located on public property	7 feet (2.1m)†	7 feet (2.1m)†
M =	Clearance under veranda, porch, deck or balcony	*12 inches (305mm)‡	12 inches (305mm)‡

¹ In accordance with the current ANSI Z223.1/NFPA 54 Natural Fuel Gas Code

² In accordance with the current CSA B149.1, Natural Gas and Propane Installation Code

† A vent shall not terminate directly above a sidewalk or paved driveway that is located between two single family dwellings and serves both dwellings.

‡ Permitted only if veranda, porch, deck or balcony is fully open on a minimum of two sides beneath the floor. Lennox recommends avoiding this location if possible.

*For clearances not specified in ANSI Z223.1/NFPA 54 or CSA B149.1, clearance will be in accordance with local installation codes and the requirements of the gas supplier and these installation instructions."

FIGURE 29

VENT TERMINATION CLEARANCES FOR DIRECT VENT INSTALLATIONS IN THE USA AND CANADA

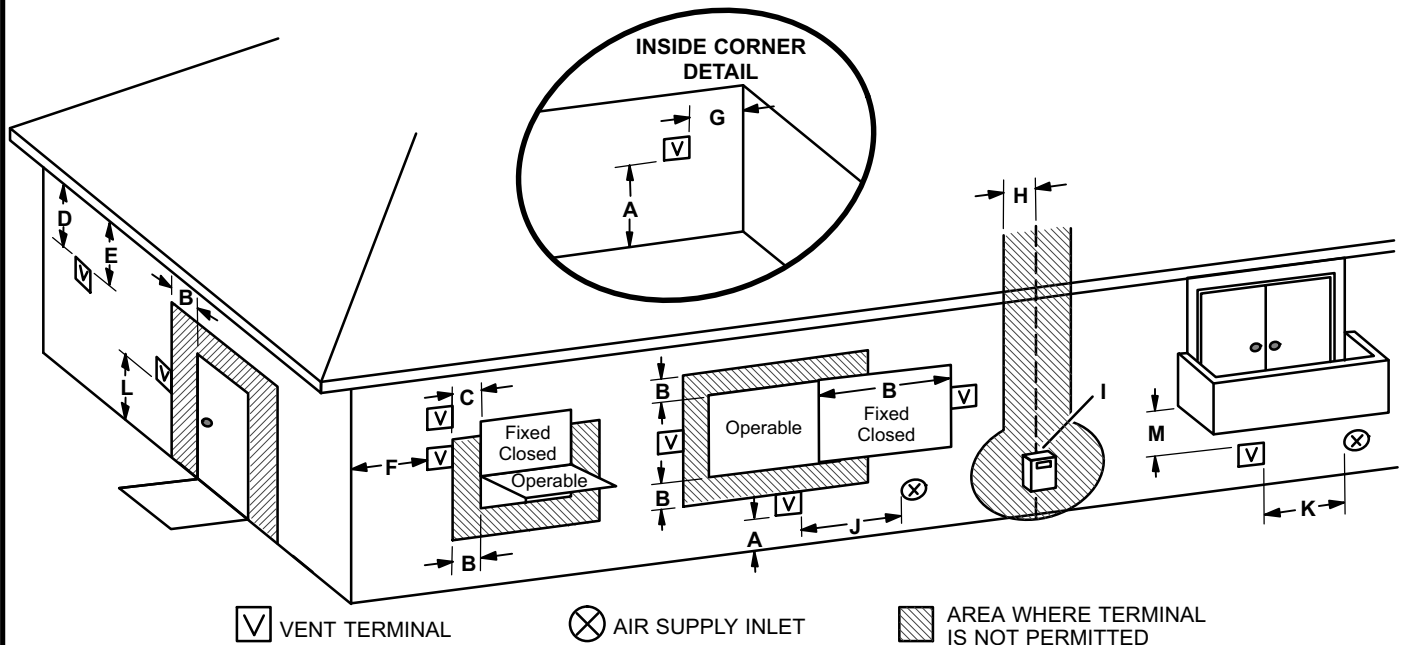

	US Installations ¹	Canadian Installations ²	
A =	Clearance above grade, veranda, porch, deck or balcony	12 inches (305mm) or 12 in. 305mm) above average snow accumulation.	12 inches (305mm) or 12 in. 305mm) above average snow accumulation.
B =	Clearance to window or door that may be opened	6 inches (152mm) for appliances <10,000 Btuh (3kw), 9 inches (mm) for appliances > 10,000 Btuh (3kw) and <50,000 Btuh (15 kw), 12 inches (305mm) for appliances > 50,000 Btuh (15kw)	6 inches (152mm) for appliances <10,000 Btuh (3kw), 12 inches (305mm) for appliances > 10,000 Btuh (3kw) and <100,000 Btuh (30kw), 36 inches (.9m) for appliances > 100,000 Btuh (30kw)
C =	Clearance to permanently closed window	* 12"	* 12"
D =	Vertical clearance to ventilated soffit located above the terminal within a horizontal distance of 2 feet (mm) from the center line of the terminal	* Equal to or greater than soffit depth	* Equal to or greater than soffit depth
E =	Clearance to unventilated soffit	* Equal to or greater than soffit depth	* Equal to or greater than soffit depth
F =	Clearance to outside corner	* No minimum to outside corner	* No minimum to outside corner
G =	Clearance to inside corner	* 3 feet (.9m)	* 3 feet (.9m)
H =	Clearance to each side of center line extended above meter / regulator assembly	3 feet (.9m) within a height 15 feet (4.5m) above the meter / regulator assembly	3 feet (.9m) within a height 15 feet (4.5m) above the meter / regulator assembly
I =	Clearance to service regulator vent outlet	* 3 feet (.9m)	3 feet (.9m)
J =	Clearance to non-mechanical air supply inlet to building or the combustion air inlet to any other appliance	6 inches (152mm) for appliances <10,000 Btuh (3kw), 9 inches (mm) for appliances > 10,000 Btuh (3kw) and <50,000 Btuh (15 kw), 12 inches (305mm) for appliances > 50,000 Btuh (15kw)	6 inches (152mm) for appliances <10,000 Btuh (3kw), 12 inches (305mm) for appliances > 10,000 Btuh (3kw) and <100,000 Btuh (30kw), 36 inches (.9m) for appliances > 100,000 Btuh (30kw)
K =	Clearance to mechanical air supply inlet	3 feet (.9m) above if within 10 feet (3m) horizontally	6 feet (1.8m)
L =	Clearance above paved sidewalk or paved driveway located on public property	* 7 feet (2.1m)	7 feet (2.1m)†
M =	Clearance under veranda, porch, deck or balcony	*12 inches (305mm)‡	12 inches (305mm)‡

¹ In accordance with the current ANSI Z223.1/NFPA 54 Natural Fuel Gas Code

² In accordance with the current CSA B149.1, Natural Gas and Propane Installation Code

† A vent shall not terminate directly above a sidewalk or paved driveway that is located between two single family dwellings and serves both dwellings.

‡ Permitted only if veranda, porch, deck or balcony is fully open on a minimum of two sides beneath the floor. Lennox recommends avoiding this location if possible.

*For clearances not specified in ANSI Z223.1/NFPA 54 or CSA B149.1, clearance will be in accordance with local installation codes and the requirements of the gas supplier and these installation instructions."

FIGURE 30

Details of Intake and Exhaust Piping Terminations for Direct Vent Installations

NOTE - In Direct Vent installations, combustion air is taken from outdoors and flue gases are discharged to outdoors.

Intake and exhaust pipes may be routed either horizontally through an outside wall or vertically through the roof. In attic or closet installations, vertical termination through the roof is preferred. Figures 31 through 39 show typical terminations.

- 1 - Exhaust and intake exits must be in same pressure zone. Do not exit one through the roof and one on the side. Also, do not exit the intake on one side and the exhaust on another side of the house or structure.
- 2 - Intake and exhaust pipes should be placed as close together as possible at termination end (refer to illustrations). Maximum separation is 3" (76mm) on roof terminations and 6" (152mm) on side wall terminations.
- 3 - If necessary, install a field-provided reducer to adapt larger vent pipe size to termination pipe size.
- 4 - On roof terminations, the intake piping should terminate straight down using two 90° elbows (See figure 31).
- 5 - Exhaust piping must terminate straight out or up as shown. In rooftop applications, a reducer may be required on the exhaust piping at the point where it exits the structure to improve the velocity of exhaust away from the intake piping. See table 8.

NOTE - Care must be taken to avoid recirculation of exhaust back into intake pipe.

- 6 - On field supplied terminations for side wall exits, exhaust piping should extend a minimum of 12 inches (305mm) beyond the outside wall. Intake piping should be as short as possible. See figure 32.
- 7 - On field supplied terminations, a minimum separation distance between the end of the exhaust pipe and the end of the intake pipe is 8 inches (203mm).
- 8 - If intake and exhaust piping must be run up a side wall to position above snow accumulation or other obstructions, piping must be supported every 3 ft. (.9m) as shown in figure 22. Refer to figure 35 for proper piping method. In addition, WTK wall termination kit must be extended for use in this application. See figure 38. When exhaust and intake piping must be run up an outside wall, the exhaust piping is reduced to 1-1/2" (38mm) after the final elbow. The intake piping may be equipped with a 90° elbow turndown. Using turndown will add 5 feet (1.5m) to the equivalent length of the pipe.
- 9 - Based on the recommendation of the manufacturer, a multiple furnace installation may use a group of up to four termination kits WTK assembled together horizontally, as shown in figure 37.

**TABLE 8
EXHAUST PIPE TERMINATION SIZE REDUCTION**

G61MP MODEL	Exhaust Pipe Size	Termination Pipe Size
045, 070, -071	2", 2-1/2", 3" or 4"	1-1/2"
090, -091	2", 2-1/2", 3" or 4"	2"
110, -111	2-1/2", 3" or 4"	*2"
135	3" or 4"	*2"

*Approved 3" concentric termination kit terminates with 2-5/8" ID pipe.

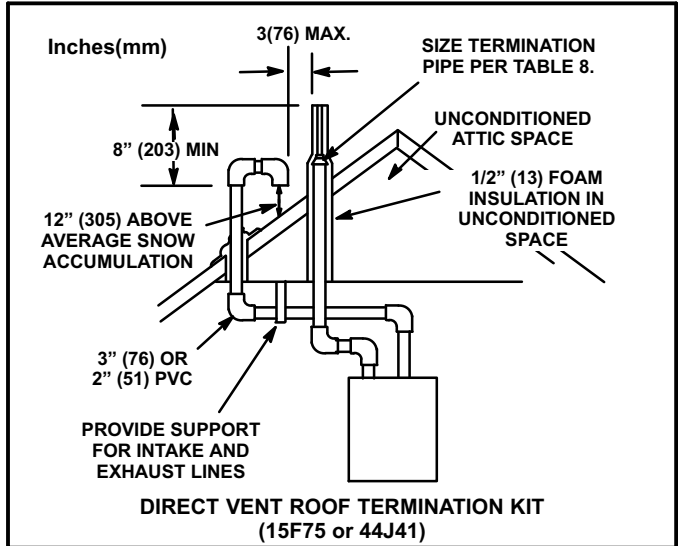

FIGURE 31

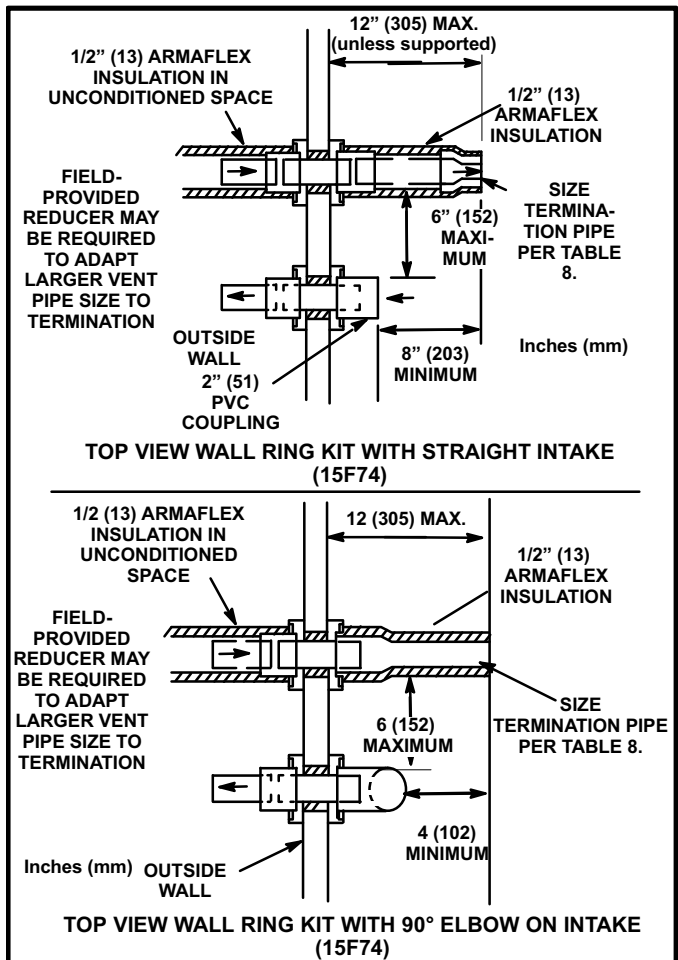

FIGURE 32

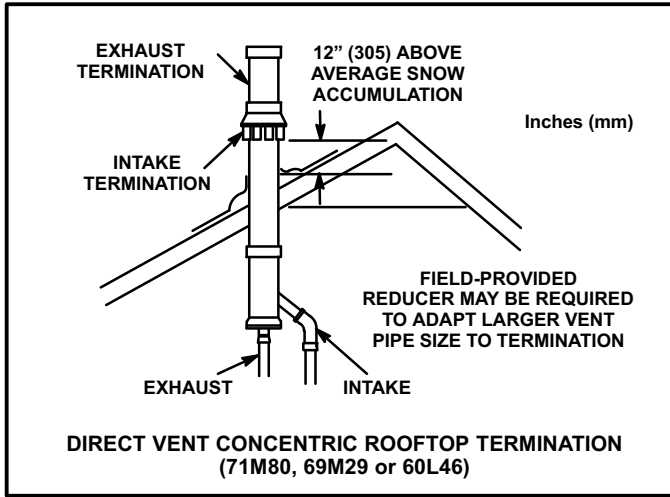

FIGURE 33

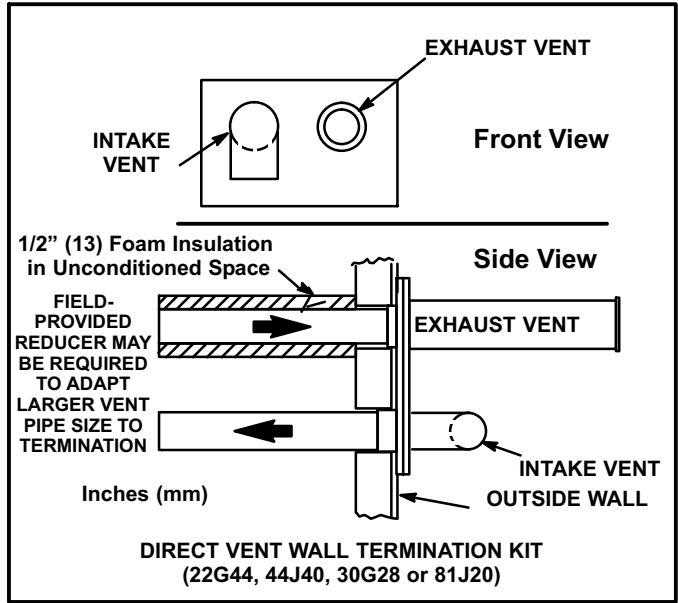

FIGURE 36

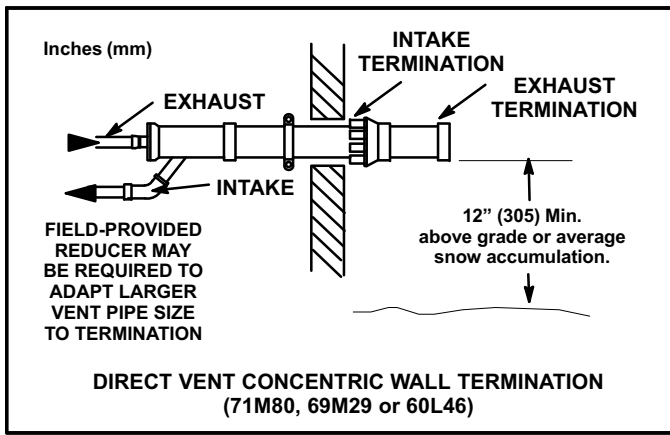

FIGURE 34

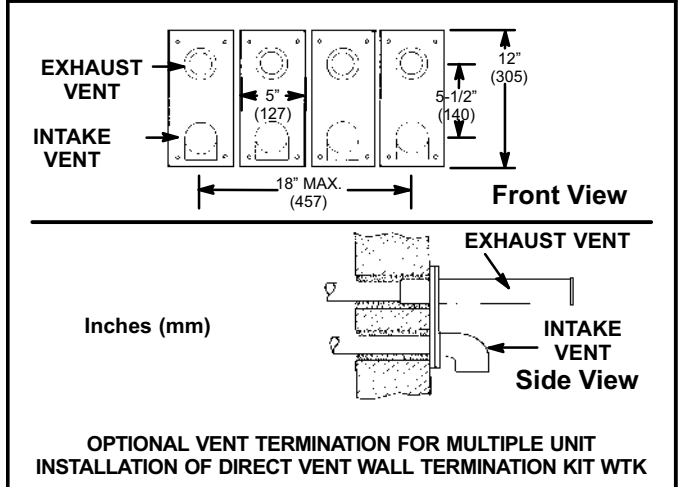

FIGURE 37

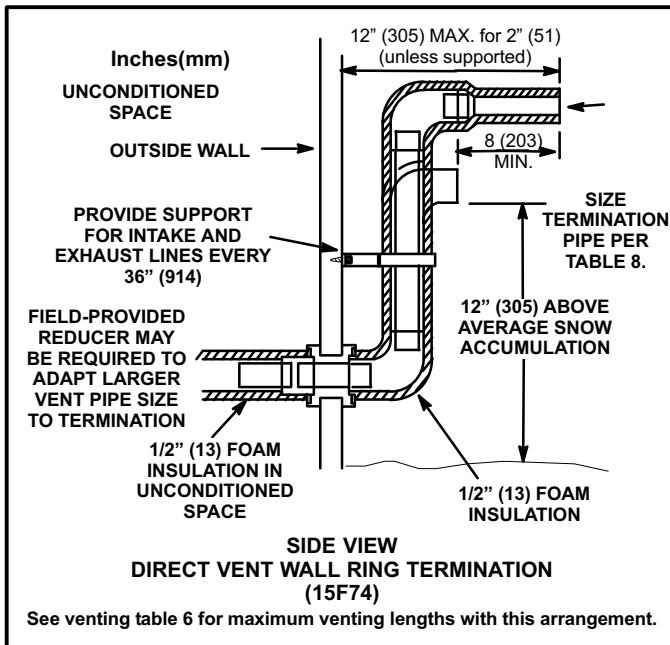

FIGURE 35

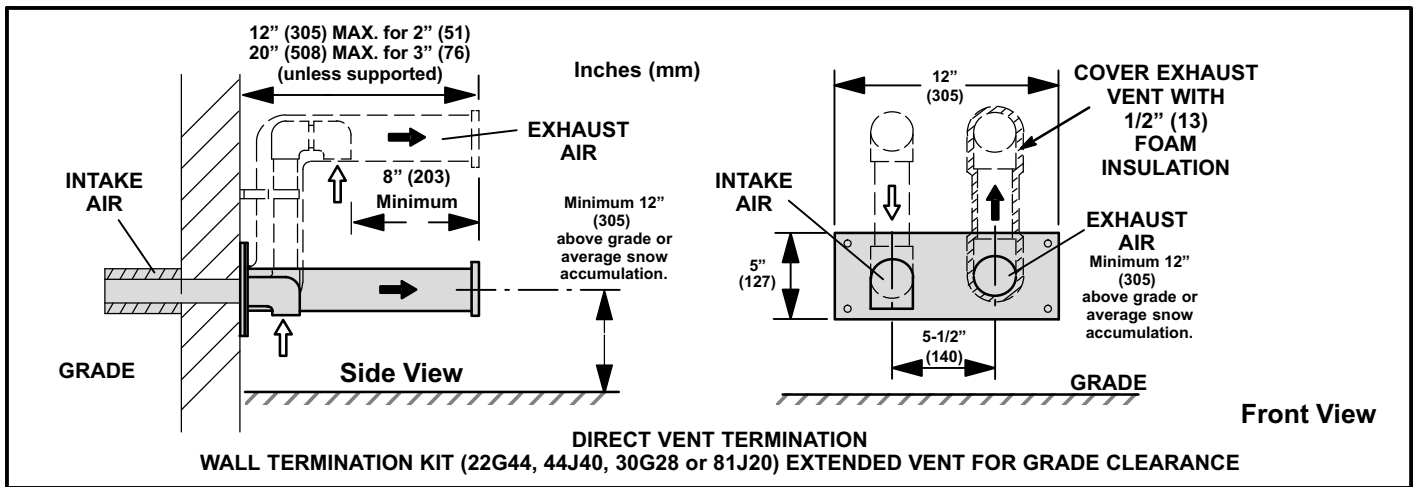

FIGURE 38

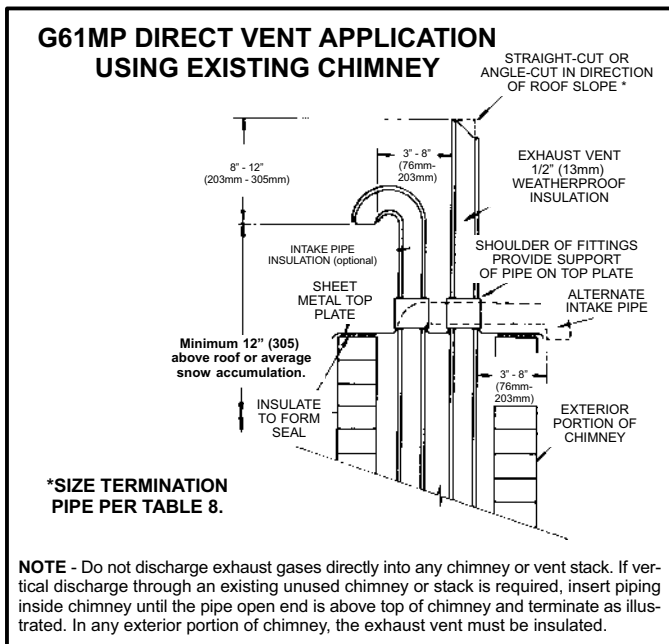

FIGURE 39

Details of Exhaust Piping Terminations for Non-Direct Vent Applications

Exhaust pipes may be routed either horizontally through an outside wall or vertically through the roof. In attic or closet installations, vertical termination through the roof is preferred. Figures 40 through 43 show typical terminations.

- 1 - Exhaust piping must terminate straight out or up as shown. The termination pipe must be sized as listed in table 8. The specified pipe size ensures proper velocity required to move the exhaust gases away from the building.
- 2 - On field supplied terminations for side wall exits, exhaust piping should extend a maximum of 12 inches (305mm) beyond the outside wall, unless support is provided in the horizontal section. See figure 41.

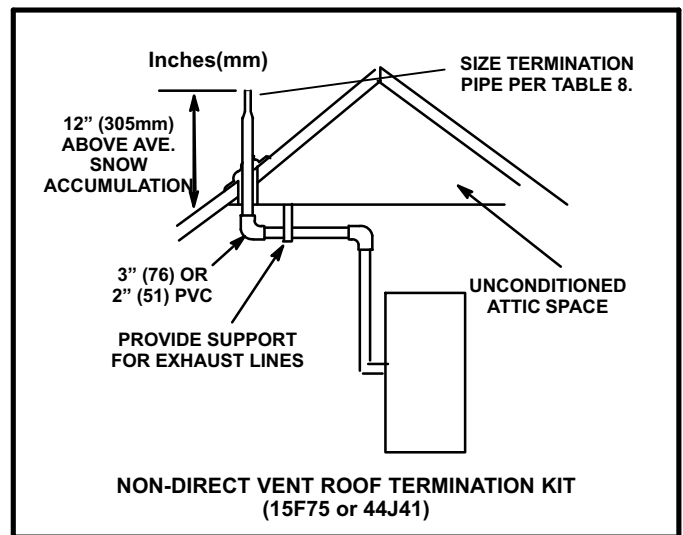

FIGURE 40

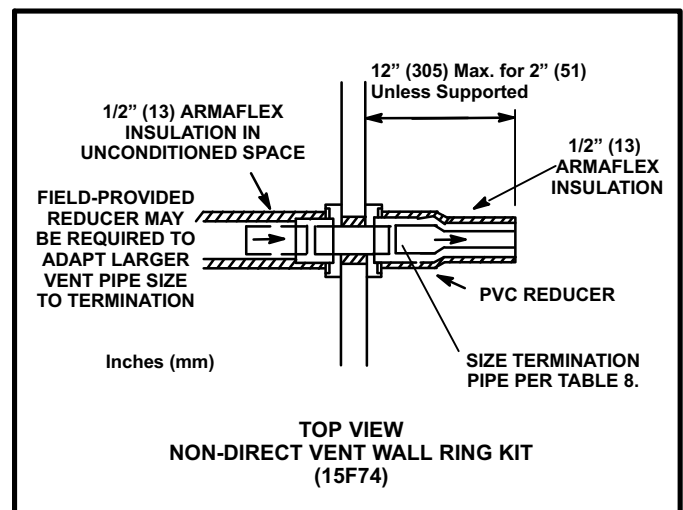

FIGURE 41

3 - If exhaust piping must be run up a side wall to position above snow accumulation or other obstructions, piping must be supported every 3 feet (.9m) as shown in figure 22. Refer to figure 42 for proper piping method. When exhaust piping must be run up an outside wall, any reduction in exhaust pipe size must be done after the final elbow.

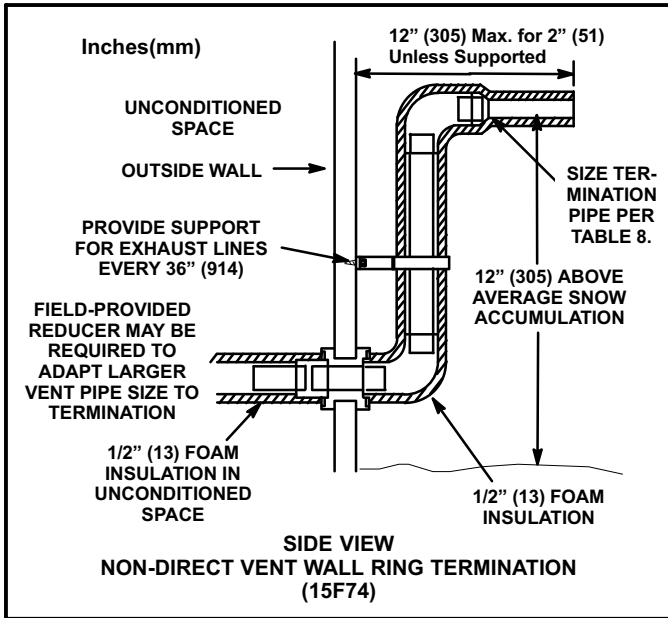

FIGURE 42

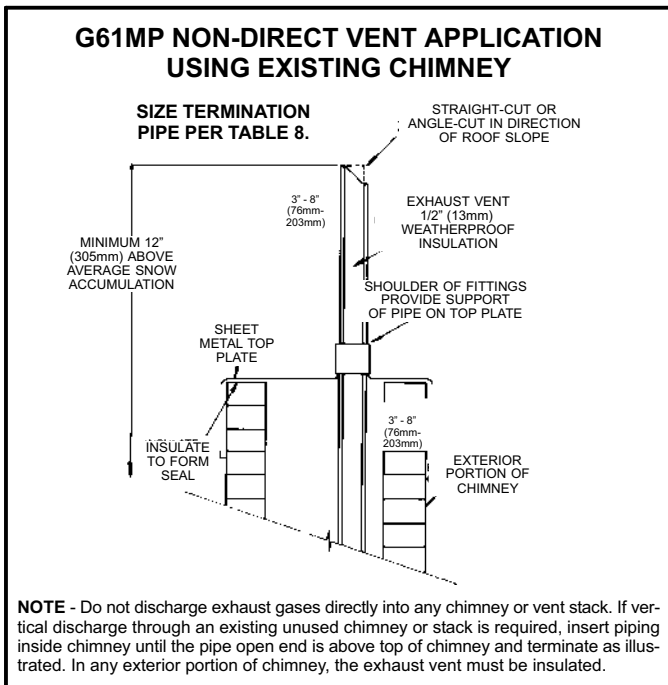

FIGURE 43

Condensate Piping

This unit is designed for either right- or left-side exit of condensate piping in either upflow or downflow applications; however, it must be installed on the same side of the unit as the exhaust piping. In horizontal applications, the conden-

sate trap should extend below the unit. A 5-1/2" service clearance is required for the condensate trap. Refer to figure 44 for condensate trap locations.

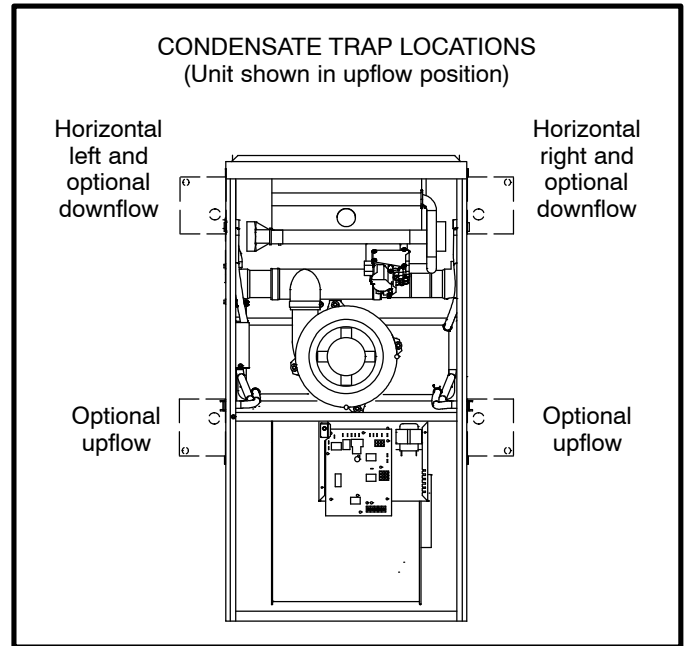

FIGURE 44

1 - Determine which side condensate piping will exit the unit. Remove plugs from the condensate collar at the appropriate location on the side of the unit.

NOTE - The condensate trap is factory-shipped with two rubber O-rings and two rubber clean-out caps installed. Check to make sure that these items are in place before installing the trap assembly.

2 - Install condensate trap onto the condensate collar. Use provided HI/LO screws to secure two upper flanges of the trap to the collar. Use provided sheet metal screw to secure bottom trap flange to side of unit. **DO NOT apply glue to secure condensate trap to cabinet.** All other joints must be glued. See figure 45.

NOTE - In upflow and downflow applications, condensate trap must be installed on the same side as exhaust piping.

CAUTION

DO NOT use a power driver to tighten screws which secure condensate trap to cabinet. Screws should be hand-tightened using a screw driver to avoid the possibility of damage to the trap assembly.

3 - The condensate trap provided with the unit is manufactured using ABS material. Use ABS to PVC transition solvent cement to glue a field-provided PVC coupling or PVC pipe to the trap. Install a tee and vent pipe near the trap.

NOTE - The condensate trap drain stubs (both sides) have an outer diameter which will accept a standard 3/4" PVC coupling. The inner diameter of each stub will accept standard 1/2" diameter PVC pipe.

NOTE - Vinyl tubing may be used for condensate drain. Tubing must be 1-1/4" OD X 1" ID and should be attached to the drain stubs on the trap using a hose clamp.

- 4 - Glue the field-provided drain line to the tee. Route the drain line to an open drain. As an alternate, clear vinyl tubing may be used to drain condensate away from the trap. Secure the vinyl tubing to the drain stubs on the trap using a hose clamp. Do not overtighten the hose clamp.

Condensate line must be sloped downward away from condensate trap to drain. If drain level is above condensate trap, condensate pump must be used. Condensate drain line should be routed within the conditioned space to avoid freezing of condensate and blockage of drain line. If this is not possible, a heat cable kit may be used on the condensate trap and line. Heating cable kit is available from Lennox in various lengths; 6 ft. (1.8m) - kit no. 26K68; 24 ft. (7.3m) - kit no. 26K69; and 50 ft. (15.2m) - kit no. 26K70.

⚠ CAUTION

Do not use copper tubing or existing copper condensate lines for drain line.

- 5 - If unit will be started immediately upon completion of installation, prime trap per procedure outlined in Unit Start-Up section.
- 6 - Glue the provided cap onto the unused condensate drain line stub.

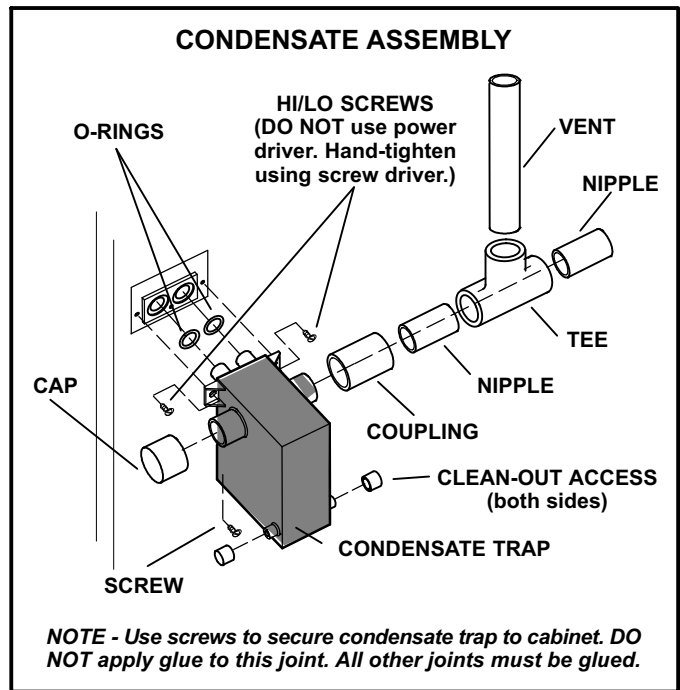

FIGURE 45

Gas Piping

⚠ CAUTION

If a flexible gas connector is required or allowed by the authority that has jurisdiction, black iron pipe shall be installed at the gas valve and extend outside the furnace cabinet.

⚠ WARNING

Do not exceed 600 in-lbs (50 ft-lbs) torque when attaching the gas piping to the gas valve.

- 1 - Gas piping may be routed into the unit through either the left- or right-hand side. Supply piping enters into the gas valve from the side of the valve as shown in figure 48.
- 2 - When connecting gas supply, factors such as length of run, number of fittings and furnace rating must be considered to avoid excessive pressure drop. Table 9 lists recommended pipe sizes for typical applications.
NOTE - Use two wrenches when connecting gas piping to avoid transferring torque to the manifold.
- 3 - Gas piping must not run in or through air ducts, clothes chutes, chimneys or gas vents, dumb waiters or elevator shafts. Center gas line through piping hole. Gas line should not touch side of unit. See figure 48.
- 4 - Piping should be sloped 1/4 inch per 15 feet (6mm per 5.6m) upward toward the gas meter from the furnace. The piping must be supported at proper intervals, every 8 to 10 feet (2.44 to 3.05m), using suitable hangers or straps. Install a drip leg in vertical pipe runs to serve as a trap for sediment or condensate.
- 5 - A 1/8" N.P.T. plugged tap or pressure post is located on the gas valve to facilitate test gauge connection. See figures 55 and 56.
- 6 - In some localities, codes may require installation of a manual main shut-off valve and union (furnished by installer) external to the unit. Union must be of the ground joint type.

⚠ IMPORTANT

Compounds used on threaded joints of gas piping must be resistant to the actions of liquified petroleum gases.

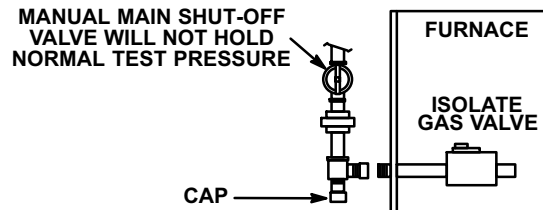

FIGURE 46

Leak Check

After gas piping is completed, carefully check all piping connections (factory- and field-installed) for gas leaks. Use a leak detecting solution or other preferred means.

The furnace must be isolated from the gas supply system by closing its individual manual shut-off valve during any pressure testing of the gas supply system at pressures less than or equal to 1/2 psig (3.48 kPa, 14 inches w.c.).

⚠ IMPORTANT

When testing pressure of gas lines, gas valve must be disconnected and isolated. See figure 46. Gas valves can be damaged if subjected to pressures greater than 1/2 psig (3.48 kPa).

⚠ WARNING

FIRE OR EXPLOSION HAZARD

Failure to follow the safety warnings exactly could result in serious injury, death, or property damage. Never use an open flame to test for gas leaks. Check all connections using a commercially available soap solution made specifically for leak detection. Some soaps used for leak detection are corrosive to certain metals. Carefully rinse piping thoroughly after leak test has been completed.

Upflow Application Left Side Piping (Standard)

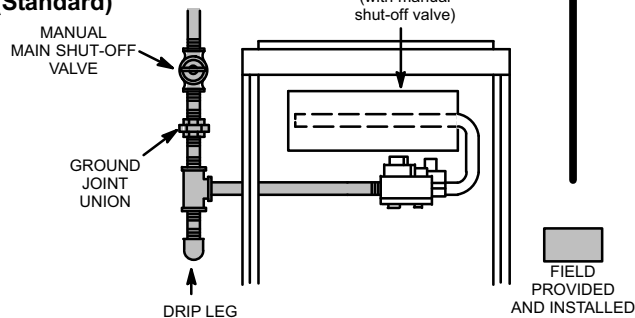

Upflow Application Right Side Piping (Alternate)

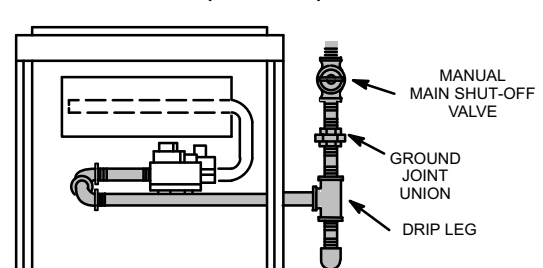

FIGURE 47

Horizontal Applications Possible Gas Piping Configurations

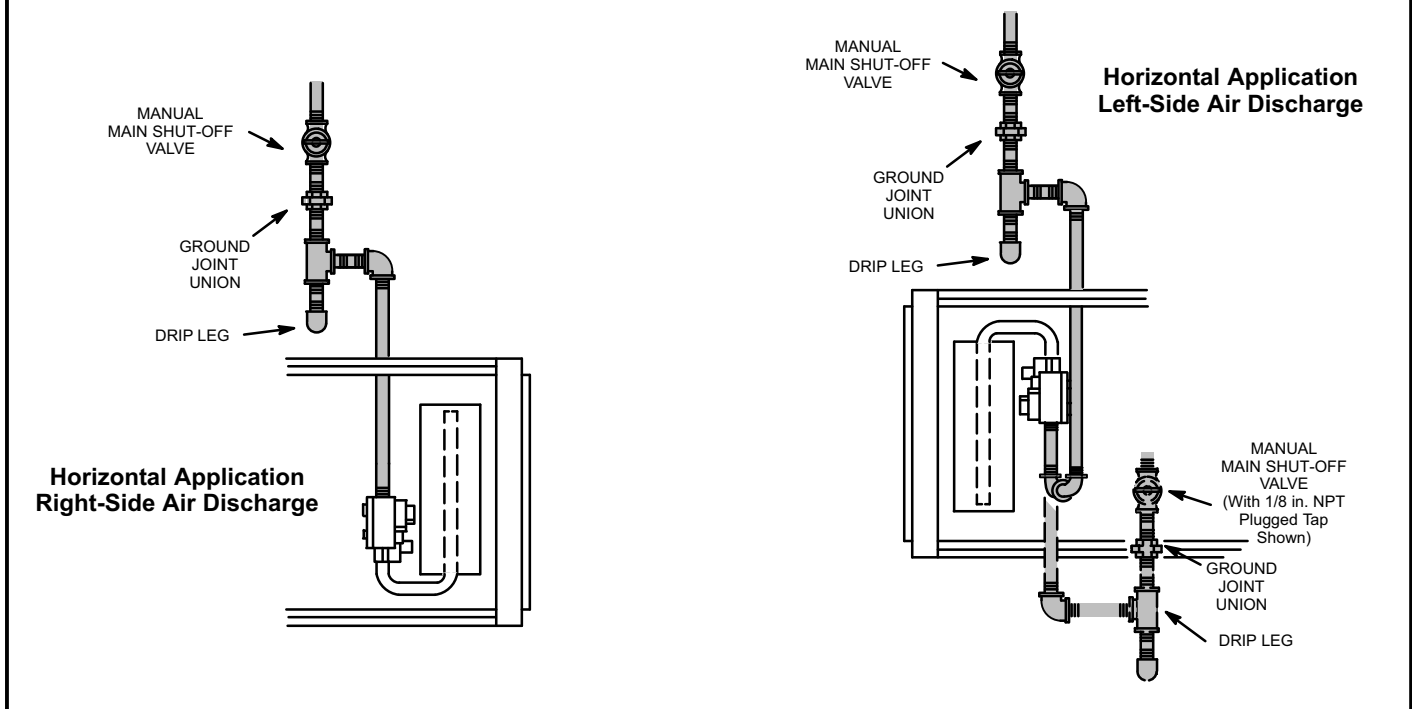

FIGURE 48

**TABLE 9
GAS PIPE CAPACITY - FT³/HR (kL/HR)**

Nominal Iron Pipe Size -Inches(mm)	Internal Diameter -Inches(mm)	Length of Pipe-Feet(m)									
		10 (3.048)	20 (6.096)	30 (9.144)	40 (12.192)	50 (15.240)	60 (18.288)	70 (21.336)	80 (24.384)	90 (27.432)	100 (30.480)
1/4 (6.35)	.364 (9.246)	43 (1.13)	29 (.82)	24 (.68)	20 (.57)	18 (.51)	16 (.45)	15 (.42)	14 (.40)	13 (.37)	12 (.34)
3/8 (9.53)	.493 (12.522)	95 (2.69)	65 (1.84)	52 (1.47)	45 (1.27)	40 (1.13)	36 (1.02)	33 (.73)	31 (.88)	29 (.82)	27 (.76)
1/2 (12.7)	.622 (17.799)	175 (4.96)	120 (3.40)	97 (2.75)	82 (2.32)	73 (2.07)	66 (1.87)	61 (1.73)	57 (1.61)	53 (1.50)	50 (1.42)
3/4 (19.05)	.824 (20.930)	360 (10.19)	250 (7.08)	200 (5.66)	170 (4.81)	151 (4.28)	138 (3.91)	125 (3.54)	118 (3.34)	110 (3.11)	103 (2.92)
1 (25.4)	1.049 (26.645)	680 (19.25)	465 (13.17)	375 (10.62)	320 (9.06)	285 (8.07)	260 (7.36)	240 (6.80)	220 (6.23)	205 (5.80)	195 (5.52)
1-1/4 (31.75)	1.380 (35.052)	1400 (39.64)	950 (26.90)	770 (21.80)	660 (18.69)	580 (16.42)	530 (15.01)	490 (13.87)	460 (13.03)	430 (12.18)	400 (11.33)
1-1/2 (38.1)	1.610 (40.894)	2100 (59.46)	1460 (41.34)	1180 (33.41)	990 (28.03)	900 (25.48)	810 (22.94)	750 (21.24)	690 (19.54)	650 (18.41)	620 (17.56)
2 (50.8)	2.067 (52.502)	3950 (111.85)	2750 (77.87)	2200 (62.30)	1900 (53.80)	1680 (47.57)	1520 (43.04)	1400 (39.64)	1300 (36.81)	1220 (34.55)	1150 (32.56)
2-1/2 (63.5)	2.469 (67.713)	6300 (178.39)	4350 (123.17)	3520 (99.67)	3000 (84.95)	2650 (75.04)	2400 (67.96)	2250 (63.71)	2050 (58.05)	1950 (55.22)	1850 (52.38)
3 (76.2)	3.068 (77.927)	11000 (311.48)	7700 (218.03)	6250 (176.98)	5300 (150.07)	4750 (134.50)	4300 (121.76)	3900 (110.43)	3700 (104.77)	3450 (97.69)	3250 (92.03)
4 (101.6)	4.026 (102.260)	23000 (651.27)	15800 (447.39)	12800 (362.44)	10900 (308.64)	9700 (274.67)	8800 (249.18)	8100 (229.36)	7500 (212.37)	7200 (203.88)	6700 (189.72)

NOTE - Capacity given in cubic feet of gas per hour (kilo liters of gas per hour) and based on 0.60 specific gravity gas.

Electrical

ELECTROSTATIC DISCHARGE (ESD)

Precautions and Procedures

⚠ CAUTION

Electrostatic discharge can affect electronic components. Take precautions during furnace installation and service to protect the furnace's electronic controls. Precautions will help to avoid control exposure to electrostatic discharge by putting the furnace, the control and the technician at the same electrostatic potential. Neutralize electrostatic charge by touching hand and all tools on an unpainted unit surface, such as the gas valve or blower deck, before performing any service procedure.

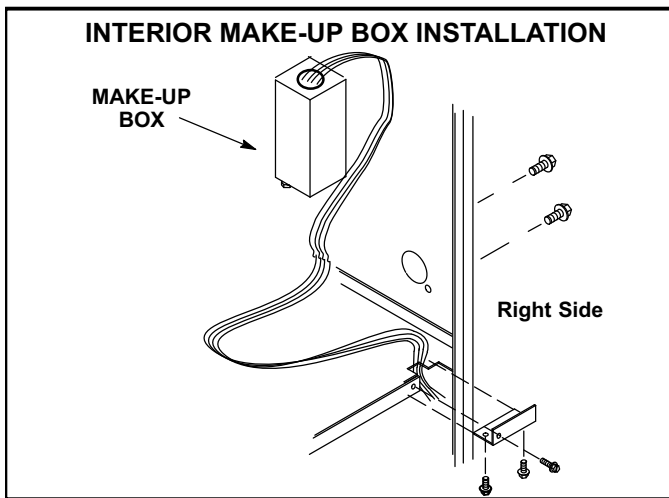

FIGURE 49

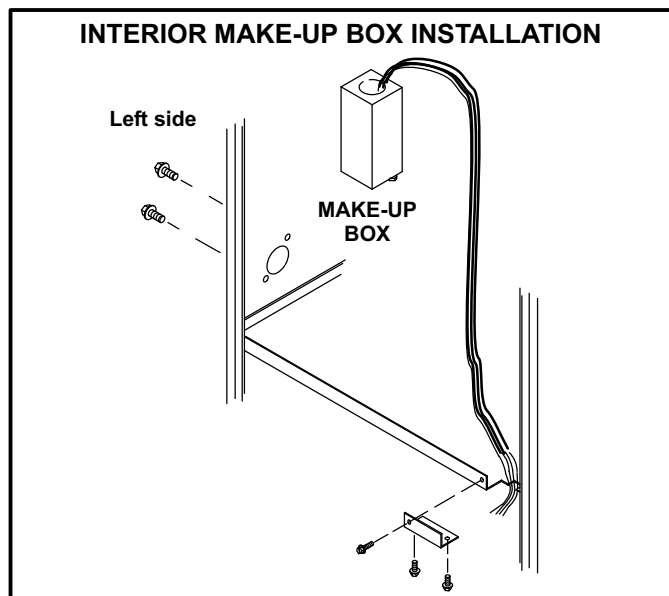

FIGURE 50

The unit is equipped with a field make-up box. The make-up box may be moved to the right side of the furnace to facilitate installation. If the make-up box is moved to the right side, the excess wire must be pulled into the blower compartment. Secure the excess wire to the existing harness to protect it from damage.

Refer to figure 51 and table 10 for field wiring and figure 54 for schematic wiring diagram and troubleshooting.

- 1 - Select circuit protection and wire size according to the unit nameplate. The power supply wiring must meet Class I restrictions.
- 2 - Holes are on both sides of the furnace cabinet to facilitate wiring.
- 3 - Install a separate disconnect switch (protected by either fuse or circuit breaker) near the furnace so that power can be turned off for servicing.
- 4 - Before connecting the thermostat or the power wiring, check to make sure the wires will be long enough for servicing at a later date. Remove the blower access panel to check the length of the wire.
- 5 - Complete the wiring connections to the equipment. Use the provided unit wiring diagram and the field wiring diagram shown in figure 51 and table 10. Use 18-gauge wire or larger that is suitable for Class II rating for thermostat connections.

NOTE - Do NOT make a wire connection between the room thermostat L terminal and the L terminal of the G61MP integrated control.

- 6 - Electrically ground the unit according to local codes or, in the absence of local codes, according to the current National Electric Code (ANSI/NFPA No. 70) for the USA and current Canadian Electric Code part 1 (CSA standard C22.1) for Canada. A green ground wire is provided in the field make-up box.

NOTE - The G61MP furnace contains electronic components that are polarity sensitive. Make sure that the furnace is wired correctly and is properly grounded.

- 7 - One line voltage "HUM" 1/4" spade terminal is provided on the furnace control board. Any humidifier rated up to one amp can be connected to this terminal with the neutral leg of the circuit being connected to one of the provided neutral terminals. See figure 52 for control board configuration. This terminal is energized in the heating mode when the combustion air inducer is operating.
- 8 - One line voltage "EAC" 1/4" spade terminal is provided on the furnace control board. Any electronic air cleaner rated up to one amp can be connected to this terminal with the neutral leg of the circuit being connected to one of the provided neutral terminals. See figure 52 for control board configuration. This terminal is energized when the indoor blower is operating.

- 9 - One 24V "H" terminal is provided on the furnace control board terminal block. Any humidifier rated up to 0.5 amp can be connected to this terminal with the ground leg of the circuit being connected to either ground or the "C" terminal. See figure 52 for control board configuration.
- 10 - Install the room thermostat according to the instructions provided with the thermostat. See table 10 for field wiring connections in varying applications. If the furnace is being matched with a heat pump, refer to the instruction packaged with the dual fuel thermostat.

Indoor Blower Speeds

- 1 - When the thermostat is set to "FAN ON," the indoor blower will run continuously on the low heat speed when there is no cooling or heating demand.
- 2 - When the G61MP is operating in the high-fire or low-fire heating mode, the indoor blower will run on the corresponding heating speed.
- 3 - When there is a cooling demand, the indoor blower will run on the corresponding cooling speed.

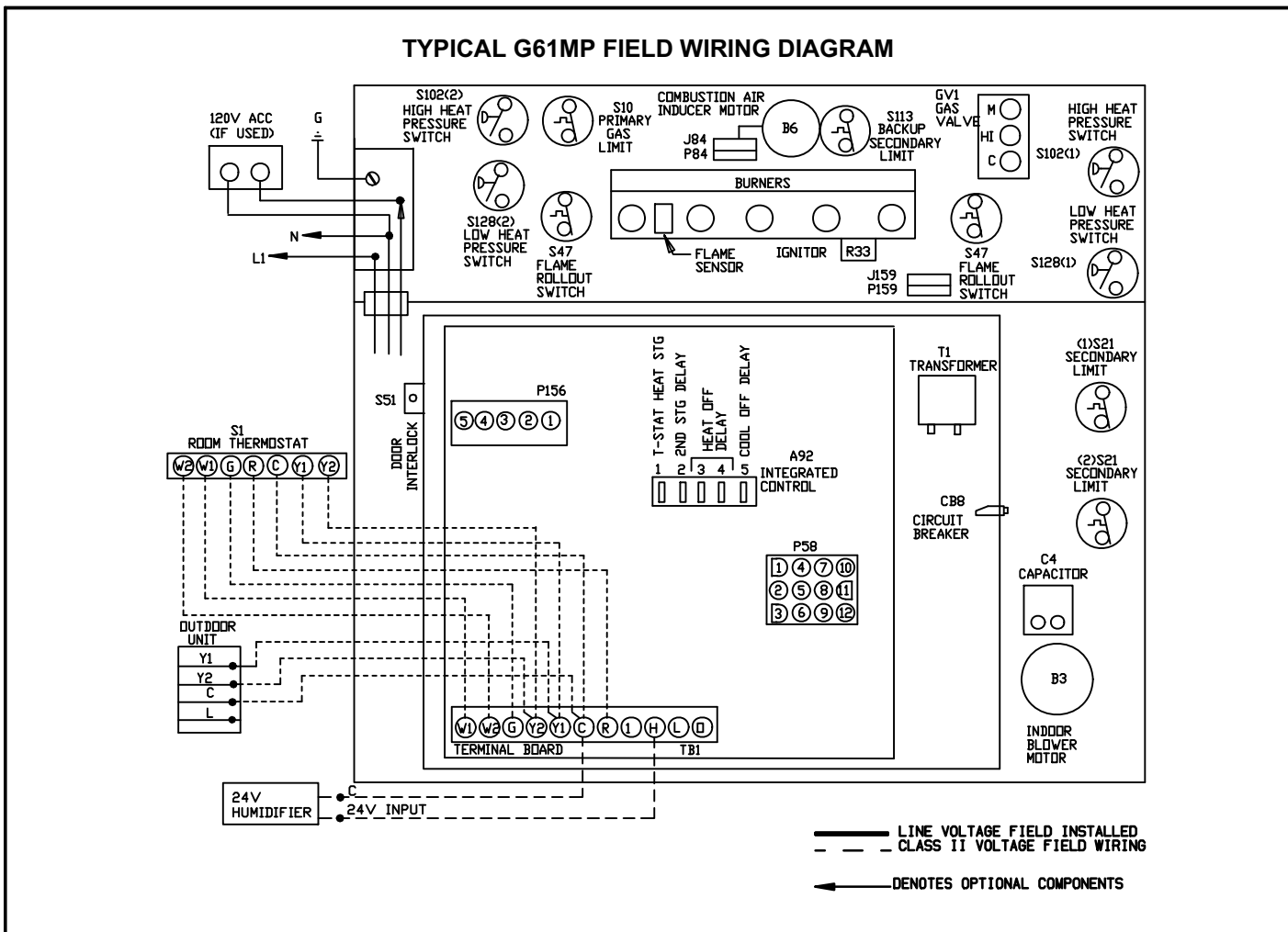

FIGURE 51

TABLE 10
Field Wiring Applications

Thermostat	DIP Switch Settings and On-Board Links (Figure 52)			Wiring Connections
	DIP Switch 1	W915 (Y1 to Y2) Two-Stage Cooling	W951 (O to R) Heat Pumps	
1 Heat / 1 Cool NOTE - Use DIP switch 2 to set second-stage heat ON delay. OFF-10 minutes. ON-15 minutes.	ON	Intact	Intact	
1 Heat / 2 Cool NOTE - Use DIP switch 2 to set second-stage heat ON delay. OFF-10 minutes. ON-15 minutes.	ON	Cut	Intact	

TABLE 10
Field Wiring Applications (Continued)

Thermostat	DIP Switch Settings and On-Board Links (Figure 52)			Wiring Connections
	DIP Switch 1	W915 (Y1 to Y2) Two-Stage Cooling	W951 (O to R) Heat Pumps	
2 Heat / 2 Cool	OFF	Cut	Intact	
2 Heat / 1 Cool	OFF	Intact	Intact	

NOTE - Do NOT make a wire connection between the room thermostat L terminal and the L terminal of the G61MP integrated control.

TWO-STAGE INTEGRATED CONTROL BOARD

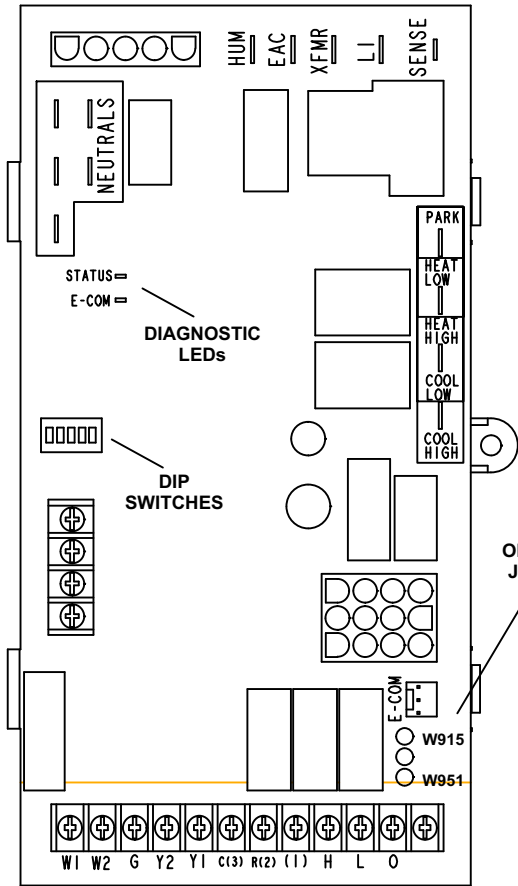

1/4" QUICK CONNECT TERMINALS

HUM = 120 VAC OUTPUT TO HUMIDIFIER
 EAC = 120 VAC OUTPUT TO ELECTRONIC AIR CLEANER
 XMFR = 120 VAC OUTPUT TO TRANSFORMER
 LI = 120 VAC INPUT TO CONTROL
 SENSE = 120 VAC OUTPUT TO FLAME SENSER

NEUTRALS= 120 VAC NEUTRAL

PARK = DEAD TERMINAL FOR UNUSED BLOWER LEAD
 HEAT LOW = 120 VAC OUTPUT TO CIRC BLWR -- LOW HT SPEED AND CONTINUOUS FAN
 HEAT HIGH/ COOL LOW = 120 VAC OUTPUT TO CIRC BLWR -- HIGH HEAT AND LOW COOL SPEED
 COOL HIGH = 120 VAC OUTPUT TO CIRC BLWR -- HIGH COOL SPEED

THERMOSTAT CONNECTIONS (TB1)

W1= HEAT DEMAND FROM 1ST STAGE T'STAT
 W2= HEAT DEMAND FROM 2ND STAGE T'STAT
 G= MANUAL FAN FROM T'STAT
 Y2= THERMOSTAT 2nd STAGE COOL SIGNAL
 Y1= THERMOSTAT 1st STAGE COOL SIGNAL
 C= THERMOSTAT SIGNAL GROUND CONNECTED TO TRANSFORMER GROUND (TR) & CHASIS GROUND (GRD)
 R= CLASS 2 VOLTAGE TO THERMOSTAT
 1= ERROR CODE RECALL
 H= 24V HUMIDIFIER OUTPUT
 L= DO NOT USE
 0= THERMOSTAT SIGNAL TO HEAT PUMP REVERSING VALVE

DIP SWITCH FUNCTIONS

DIP SWITCH(ES)	FUNCTION
1 -- 2 Stage T'stat	Selects t'stat type (single or two-stage)
2 -- 2nd Stage Delay	Second stage ON delay (single-stage t'stat)
3 & 4 -- Heat Off Delay	Heating fan OFF delay
5 -- Cool Off Delay	Cooling fan OFF delay

FIGURE 52

INTEGRATED CONTROL BOARD DIP SWITCH SETTINGS AND JUMPERS

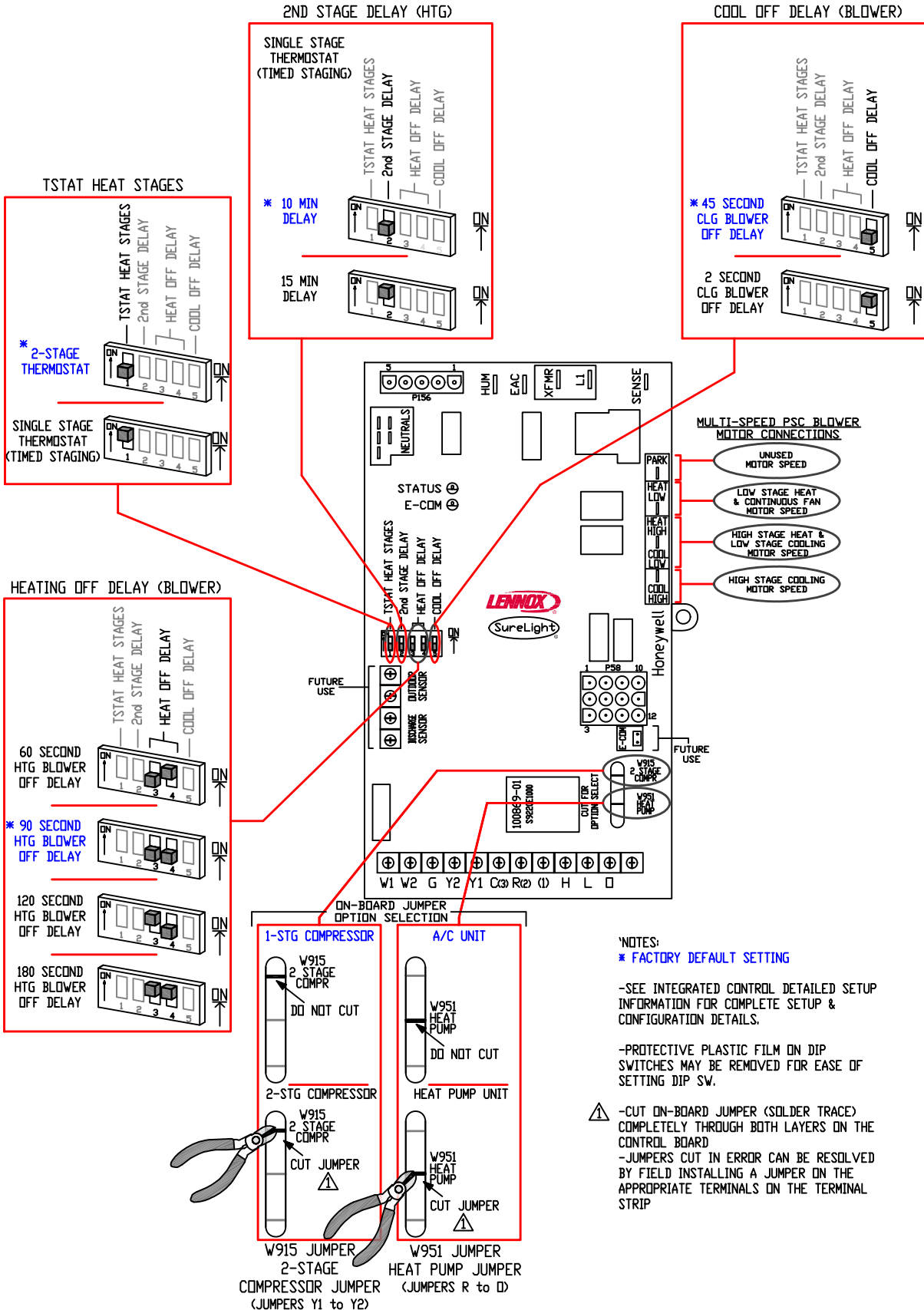

FIGURE 53

TYPICAL G61MP WIRING DIAGRAM

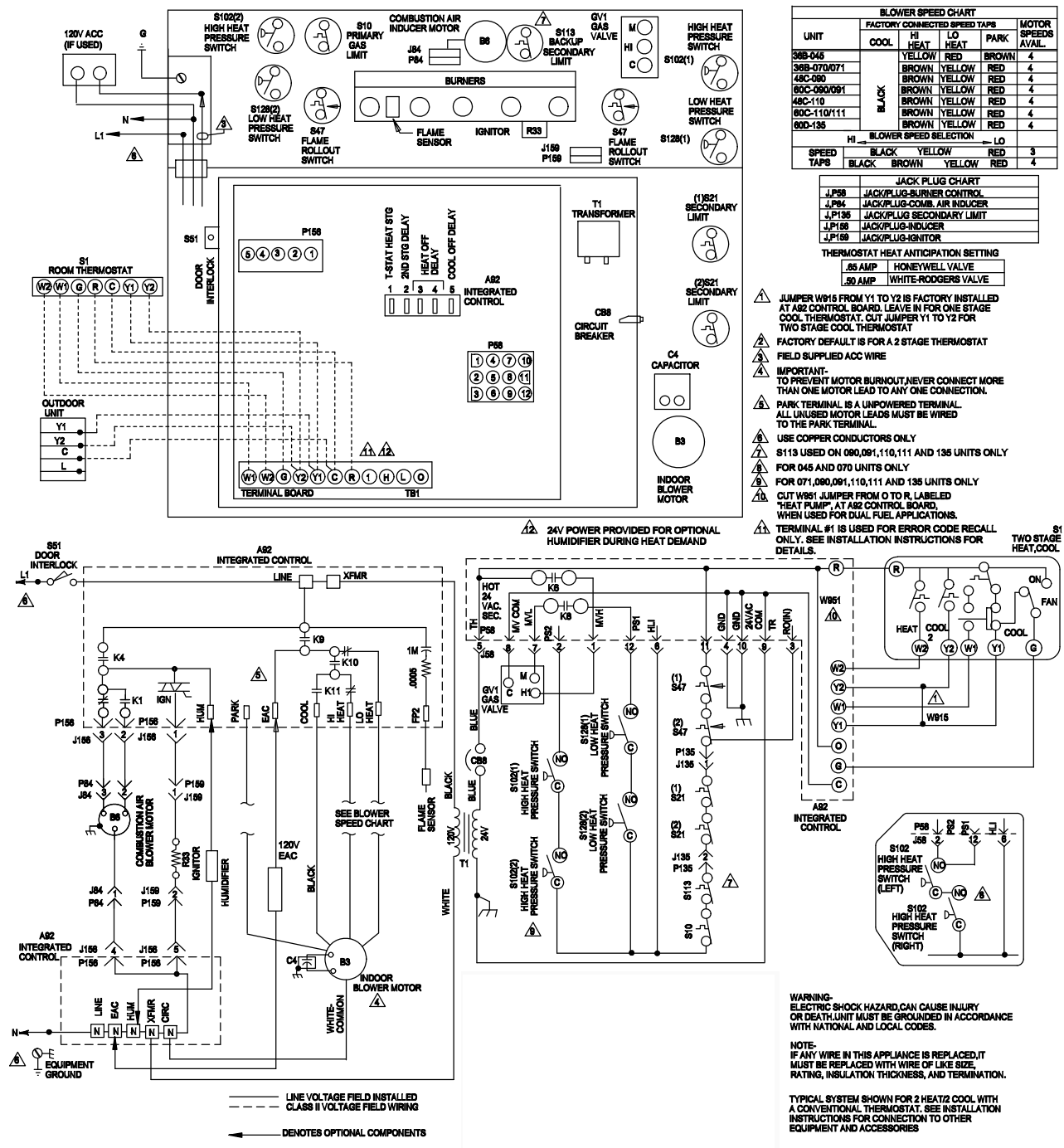

FIGURE 54

Integrated Control Board

G61MP units are equipped with a two-stage integrated control. This control manages ignition timing and fan off delays based on selections made using the control DIP switches and jumpers. The control includes an internal watchdog feature which automatically resets the ignition control when it has been locked out. After one hour of continuous thermostat demand for heat, the watchdog will break and remake thermostat demand to the furnace and automatically reset the control to relight the furnace.

DIP Switch Settings -- Figure 53

Switch 1 -- Thermostat Selection -- This unit may be used with either a single-stage or two-stage thermostat. The thermostat selection is made using a DIP switch which must be properly positioned for the particular application. The DIP switch is factory-positioned for use with a two-stage thermostat. If a single-stage thermostat is to be used, the DIP switch must be repositioned.

- a - Select "OFF" for two-stage heating operation controlled by a two-stage heating thermostat (factory setting);
- b - Select "ON" for two-stage heating operation controlled by a single-stage heating thermostat. This setting provides a timed delay before second-stage heat is initiated.

Switch 2 -- Second Stage Delay (Used with Single-Stage Thermostat Only) -- This switch is used to determine the second stage on delay when a single-stage thermostat is being used. The switch is factory-set in the OFF position, which provides a 10-minute delay before second-stage heat is initiated. If the switch is toggled to the ON position, it will provide a 15-minute delay before second-stage heat is initiated. This switch is only activated when the thermostat selector jumper is positioned for SINGLE-stage thermostat use.

Switches 3 and 4 -- Heating Blower-Off Delay -- The heating blower-on delay of 45 seconds is not adjustable. The heating blower-off delay (time that the blower operates after the heating demand has been satisfied) can be adjusted by moving switches 3 and 4 on the integrated control board. The unit is shipped from the factory with a heating blower-off delay of 90 seconds. The heating blower off delay affects comfort and is adjustable to satisfy individual applications. Adjust the blower off delay to achieve a supply air temperature between 90° and 110°F at the exact moment that the blower is de-energized. Longer off delay settings provide lower supply air temperatures; shorter settings provide higher supply air temperatures. Table 11 provides the blower off timings that will result from different switch settings.

TABLE 11
Heating Blower-Off Delay Switch Settings

Blower Off Delay (Seconds)	Switch 3	Switch 4
60	Off	On
90	Off	Off
120	On	Off
180	On	On

Switch 5 -- Cooling Blower-Off Delay -- The cooling blower-off delay (time that the blower operates after the cooling demand has been satisfied) can be adjusted by moving switch 5 on the integrated control board. The switch is factory-set in the OFF position, which provides a cooling blower-off delay of 45 seconds. If the switch is toggled to the ON position, it will provide a 2-second cooling blower-off delay

On-Board Jumper W951 -- Figure 53

On-board jumper W951, which connects terminals R and O on the integrated control board, must be cut when the furnace is installed in applications which include a heat pump unit and a thermostat which features dual fuel use. If the jumper is left intact, terminal "O" will remain energized eliminating the HEAT MODE in the heat pump.

On-Board Jumper W915 -- Figure 53

On-board jumper W915, which connects terminals Y1 and Y2 on the integrated control board, must be cut if two-stage cooling will be used. If the jumper is not cut the outdoor unit will operate in first-stage cooling only.

Unit Start-Up

FOR YOUR SAFETY READ BEFORE OPERATING

⚠ WARNING

Do not use this furnace if any part has been underwater. A flood-damaged furnace is extremely dangerous. Attempts to use the furnace can result in fire or explosion. Immediately call a qualified service technician to inspect the furnace and to replace all gas controls, control system parts, and electrical parts that have been wet or to replace the furnace, if deemed necessary.

⚠ WARNING



Danger of explosion. Can cause injury or product or property damage. Should the gas supply fail to shut off or if overheating occurs, shut off the gas valve to the furnace before shutting off the electrical supply.

⚠ CAUTION

Before attempting to perform any service or maintenance, turn the electrical power to unit OFF at disconnect switch.

Priming Condensate Trap

The condensate trap should be primed with water prior to start-up to ensure proper condensate drainage. Either pour 10 fl. oz. (300 ml) of water into the trap, or follow these steps to prime the trap:

- 1 - Follow the lighting instructions to place the unit into operation.
- 2 - Set the thermostat to initiate a heating demand.
- 3 - Allow the burners to fire for approximately 3 minutes.
- 4 - Adjust the thermostat to deactivate the heating demand.
- 5 - Wait for the combustion air inducer to stop. Set the thermostat to initiate a heating demand and again allow the burners to fire for approximately 3 minutes.
- 6 - Adjust the thermostat to deactivate the heating demand and again wait for the combustion air inducer to stop. At this point, the trap should be primed with sufficient water to ensure proper condensate drain operation.

BEFORE LIGHTING the unit, smell all around the furnace area for gas. Be sure to smell next to the floor because some gas is heavier than air and will settle on the floor.

The gas valve on the G61MP will be equipped with a gas control switch (lever). Use only your hand to move the switch. Never use tools. If the the switch will not move by hand, do not try to repair it. Force or attempted repair may result in a fire or explosion.

Placing the furnace into operation:

G61MP units are equipped with an automatic ignition system. Do not attempt to manually light burners on this furnace. Each time the thermostat calls for heat, the burners will automatically light. The ignitor does not get hot when there is no call for heat on units with this ignition system.

⚠ WARNING

If you do not follow these instructions exactly, a fire or explosion may result causing property damage, personal injury or death.

Gas Valve Operation (Figures 55 and 56)

- 1 - **STOP!** Read the safety information at the beginning of this section.
- 2 - Set the thermostat to the lowest setting.
- 3 - Turn off all electrical power to the unit.

- 4 - This furnace is equipped with an ignition device which automatically lights the burners. Do **not** try to light the burners by hand.
- 5 - Remove the upper access panel.
- 6 - *White Rodgers 36E Gas Valve* - Move gas valve switch to **OFF**. See figure 55 for the White Rodgers 36E valve.
Honeywell VR8205 Gas Valve - Move switch on gas valve clockwise ➡ to **OFF**. Do not force. See figure 56.
- 7 - Wait five minutes to clear out any gas. If you then smell gas, **STOP!** Immediately call your gas supplier from a neighbor's phone. Follow the gas supplier's instructions. If you do not smell gas go to next step.

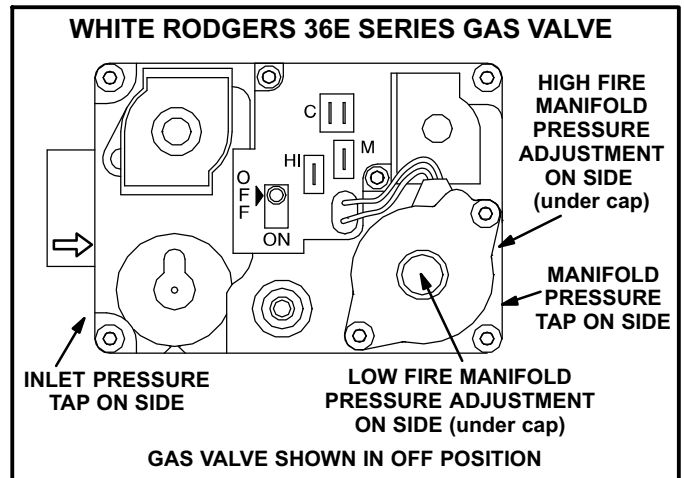

FIGURE 55

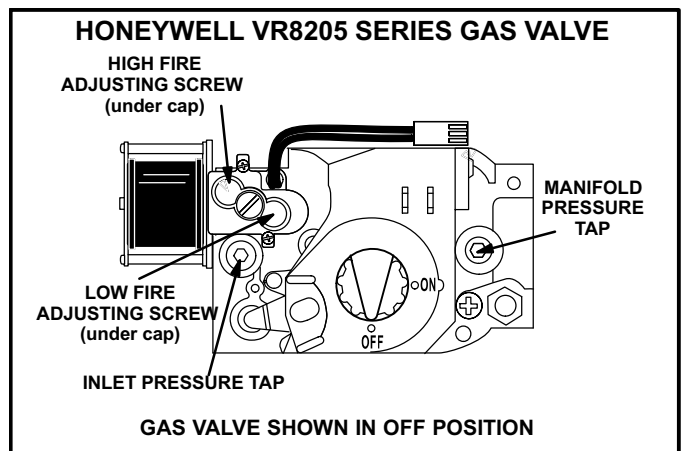



FIGURE 56

- 8 - *White Rodgers 36E Gas Valve* - Move gas valve switch to **ON**. See figure 55 for the White Rodgers 36E valve.
Honeywell VR8205 Gas Valve - Move switch on gas valve counterclockwise ⬅ to **ON**. Do not force.
 - 9 - Replace the upper access panel.
 - 10 - Turn on all electrical power to the unit.
 - 11 - Set the thermostat to desired setting.
- NOTE** - When unit is initially started, steps 1 through 11 may need to be repeated to purge air from gas line.

- 12- If the appliance will not operate, follow the instructions "Turning Off Gas to Unit" and call your service technician or gas supplier.

Turning Off Gas to Unit

- 1 - Set the thermostat to the lowest setting.
- 2 - Turn off all electrical power to the unit if service is to be performed.
- 3 - Remove the upper access panel.
- 4 - *White Rodgers 36E Gas Valve* - Move gas valve switch to **OFF**.
Honeywell VR8205 Gas Valve - Move switch on gas valve clockwise  to **OFF**. Do not force.
- 5 - Replace the upper access panel.

Gas Pressure Adjustment

Gas Flow (Approximate)

- 1 - Operate unit at least 15 minutes before checking gas flow. Determine the time in seconds for one revolutions of gas through the meter. A portable LP gas meter (17Y44) is available for LP applications.
- 2 - Compare the number of seconds and the gas meter size in table 12 to determine the gas flow rate. Multiply the gas flow rate by the heating value to determine the unit input rate. If manifold pressure is correct and the unit input rate is incorrect, check gas orifices for proper size and restriction.
- 3 - Remove temporary gas meter if installed.

NOTE - To obtain accurate reading, shut off all other gas appliances connected to meter.

Supply Pressure Measurement

A threaded plug on the inlet side of the gas valve provides access to the supply pressure tap. Remove the threaded plug, install a field-provided barbed fitting and connect a manometer to measure supply pressure. Replace the threaded plug after measurements have been taken.

Manifold Pressure Measurement

To correctly measure manifold pressure, the differential pressure between the positive gas manifold and the negative burner box must be considered. Use *pressure test adapter kit (available as Lennox part 10L34)* to assist in measurement.

- 1 - Remove the threaded plug from the outlet side of the gas valve and install a field-provided barbed fitting. Connect test gauge "+" connection to barbed fitting to measure manifold pressure.

- 2 - Tee into the gas valve regulator vent hose and connect test gauge "-" connection.

TABLE 12

Gas Flow Rate (Ft. ³ /Hr.)		
Seconds for 1 Revolution	Gas Meter Size	
	1/2 cu ft Dial	1 cu ft Dial
10	180	360
12	150	300
14	129	257
16	113	225
18	100	200
20	90	180
22	82	164
24	75	150
26	69	138
28	64	129
30	60	120
32	56	113
34	53	106
36	50	100
38	47	95
40	45	90
42	43	86
44	41	82
46	39	78
48	38	75
50	36	72
52	35	69
54	33	67
56	32	64
58	31	62
60	30	60

- 3 - Start unit on low heat (68% rate) and allow 5 minutes for unit to reach steady state.
- 4 - While waiting for the unit to stabilize, notice the flame. Flame should be stable and should not lift from burner. Natural gas should burn blue.
- 5 - After allowing unit to stabilize for 5 minutes, record manifold pressure and compare to value given in table 13.
- 6 - Repeat steps 3, 4 and 5 on high heat.

NOTE - Shut unit off and remove manometer as soon as an accurate reading has been obtained. Take care to remove barbed fitting and replace threaded plug.

 CAUTION
Do not attempt to make adjustments to the gas valve.

TABLE 13
Manifold Pressure (Outlet) inches w.c.

Model Number	Fuel	Altitude (feet)											
		0-2000		2001-4500		4501-5500		5501-6500		6501-7500		7501-10000	
		Low Fire	High Fire	Low Fire	High Fiire	Low Fire	High Fiire	Low Fire	High Fiire	Low Fire	High Fiire	Low Fire	High Fiire
045, 070, 090, 110, 135	Natural	1.7	3.5	1.7	3.5	1.7	3.5	1.7	3.5	1.7	3.5	1.7	3.5
	Propane	4.9	10.0	4.9	10.0	4.9	10.0	4.9	10.0	4.9	10.0	4.9	10.0
071, 091, 111	Natural	1.7	3.5	1.7	3.4	1.7	3.3	1.7	3.2	1.7	3.1	1.7	3.5
	Propane	4.9	10.0	4.9	10.0	4.9	10.0	4.9	10.0	4.9	10.0	4.9	10.0

High Altitude Information

NOTE - In Canada, certification for installations at elevations over 4500 feet (1372 m) is the jurisdiction of local authorities.

The manifold pressure may require adjustment to ensure proper operation at higher altitudes. Refer to table 13 for proper manifold pressure settings at varying altitudes. Refer to table 14 for required pressure switch changes and conversion kits at varying altitudes.

The combustion air pressure switches are factory-set and require no adjustment.

NOTE - A natural to L.P. propane gas changeover kit is necessary to convert this unit. Refer to the changeover kit installation instruction for the conversion procedure.

TABLE 14
Conversion Kit Requirements

Input	High Altitude Orifice Kit Natural Gas Only 7501-10,000 ft.	High Altitude Pressure Switch Kit ORDER TWO EACH			LPG/Propane Kit		LPG/Propane to Natural Gas Kit	
		2000-4500 ft.	4501-7500 ft.	7501-10,000 ft.	0-7500 ft.	7501-10,000 ft.	0-7500 ft.	¹ 7501-10,000 ft.
-045	44W51	---	---	---	44W48	44W50	44W49	44W49 + 44W51
-070	44W51	---	---	56M06	44W48	44W50	44W49	44W49 + 44W51
-071	47M82	24W49	24W49	26W83	44W48	44W50	44W49	44W49 + 47M82
-090	44W51	---	75M22	56M21	44W48	44W50	44W49	44W49 + 44W51
-091	47M82	26W85	26W85	26W86	44W48	44W50	44W49	44W49 + 47M82
-110	44W51	---	---	75M22	44W48	44W50	44W49	44W49 + 44W51
-111	47M82	56M22	56M22	56M23	44W48	44W50	44W49	44W49 + 47M82
-135	44W51	---	56M93	56M93	44W48	44W50	44W49	44W49 + 44W51

¹ High Altitude Orifice Kit is required and must be ordered separately for applications from 7501 to 10,000 ft.

Testing for Proper Venting and Sufficient Combustion Air for Non-Direct Vent Applications

WARNING

CARBON MONOXIDE POISONING HAZARD!

Failure to follow the steps outlined below for each appliance connected to the venting system being placed into operation could result in carbon monoxide poisoning or death.

The following steps shall be followed for each appliance connected to the venting system being placed into operation, while all other appliances connected to the venting system are not in operation.

After the G61MP gas furnace has been started, the following test should be conducted to ensure proper venting and sufficient combustion air has been provided to the G61MP, as well as to other gas-fired appliances which are separately vented.

If a G61MP furnace replaces a Category I furnace which was commonly vented with another gas appliance, the size of the existing vent pipe for that gas appliance must be checked. Without the heat of the original furnace flue products, the existing vent pipe is probably oversized for the single water heater or other appliance. The vent should be checked for proper draw with the remaining appliance.

The test should be conducted while all appliances (both in operation and those not in operation) are connected to the venting system being tested. If the venting system has been installed improperly, or if provisions have not been made for sufficient amounts of combustion air, corrections must be made as outlined in the previous section.

- 1 - Seal any unused openings in the venting system.
- 2 - Visually inspect the venting system for proper size and horizontal pitch. Determine there is no blockage or restriction, leakage, corrosion, or other deficiencies which could cause an unsafe condition.
- 3 - To the extent that it is practical, close all building doors and windows and all doors between the space in which the appliances connected to the venting system are located and other spaces of the building.
- 4 - Close fireplace dampers.
- 5 - Turn on clothes dryers and any appliances not connected to the venting system. Turn on any exhaust fans, such as range hoods and bathroom exhausts, so they will operate at maximum speed. Do not operate a summer exhaust fan.
- 6 - Follow the lighting instruction to place the appliance being inspected into operation. Adjust thermostat so appliance will operate continuously.
- 7 - Use the flame of match or candle to test for spillage of flue gases at the draft hood relief opening after 5 minutes of main burner operation.
- 8 - If improper venting is observed during any of the above tests, the venting system must be corrected or

sufficient combustion/make-up air must be provided. The venting system should be re-sized to approach the minimum size as determined by using the appropriate tables in appendix G in the current standards of the National Fuel Gas Code ANSI-Z223.1/NPFA 54 in the U.S.A., and the appropriate Natural Gas and Propane appliances venting sizing tables in the current standard of the CSA-B149 Natural Gas and Propane Installation Codes in Canada.

- 9 - After determining that each appliance remaining connected to the common venting system properly vents when tested as indicated in step 3, return doors, windows, exhaust fans, fireplace dampers and any other gas-burning appliance to their previous condition of use.

Other Unit Adjustments

Primary and Secondary Limits

The primary limit is located on the heating compartment vestibule panel. The secondary limits are located in the blower compartment, attached to the back side of the blower. These limits are factory set and require no adjustment.

Flame Rollout Switches (Two)

These manually reset switches are located on the burner box. If tripped, check for adequate combustion air before resetting.

Pressure Switches (Two or Four)

The pressure switches are located in the heating compartment on the combustion air inducer. These switches check for proper combustion air inducer operation before allowing ignition trial. The switches are factory-set and require no adjustment.

Back-Up Secondary Limit (090, 110 & 135 Models)

The back-up secondary limit is located on the combustion air inducer. This switch protects the plastic components from overheating due to indoor blower motor failure. If tripped, check for proper blower operation before resetting.

Temperature Rise

After the furnace has been started and supply and return air temperatures have been allowed to stabilize, check the temperature rise. If necessary, adjust the blower speed to maintain the temperature rise within the range shown on the unit nameplate. Increase the blower speed to decrease the temperature. Decrease the blower speed to increase the temperature rise. Failure to do adjust the temperature rise may cause erratic limit operation.

Thermostat Heat Anticipation

Set the heat anticipator setting (if adjustable) according to the amp draw listed on the wiring diagram that is attached to the unit.

Electrical

- 1 - Check all wiring for loose connections.

- 2 - Check for the correct voltage at the furnace (furnace operating).
- 3 - Check amp-draw on the blower motor.

Motor Nameplate _____ Actual _____

NOTE - Do not secure the electrical conduit directly to the air ducts or structure.

Blower Speeds

NOTE - CFM readings are taken external to unit with a dry evaporator coil and without accessories.

- 1 - Turn off electrical power to furnace.
- 2 - Remove blower access panel.
- 3 - Disconnect existing speed tap at control board speed terminal.

NOTE - Termination of any unused motor leads must be insulated.

- 4 - Refer to blower speed selection chart on unit wiring diagram for desired heating or cooling speed. See blower performance data beginning on Page 48.
- 5 - Connect selected speed tap at control board speed terminal.
- 6 - Resecure blower access panel.
- 7 - Turn on electrical power to furnace.

Electronic Ignition

The integrated control has an added feature of an internal Watchguard control. The feature serves as an automatic reset device for ignition control lockout caused by ignition failure. This type of lockout is usually due to low gas line pres-

sure. After one hour of continuous thermostat demand for heat, the Watchguard will break and remake thermostat demand to the furnace and automatically reset the control to begin the ignition sequence.

Exhaust and Air Intake Pipe

- 1 - Check exhaust and air intake connections for tightness and to make sure there is no blockage.
- 2 - Are pressure switches closed? Obstructed exhaust pipe will cause unit to shut off at pressure switches. Check termination for blockages.
- 3 - Reset manual flame rollout switches on burner box cover.

Failure To Operate

If the unit fails to operate, check the following:

- 1 - Is the thermostat calling for heat?
- 2 - Are access panels securely in place?
- 3 - Is the main disconnect switch closed?
- 4 - Is there a blown fuse?
- 5 - Is the filter dirty or plugged? Dirty or plugged filters will cause the limit control to shut the unit off.
- 6 - Is gas turned on at the meter?
- 7 - Is the manual main shut-off valve open?
- 8 - Is the internal manual shut-off valve open?
- 9 - Is the unit ignition system in lock out? If the unit locks out again, inspect the unit for blockages.

Blower Performance Data

G61MP-36B-045 PERFORMANCE (Less Filter)

External Static Pressure in. w.g.	Air Volume / Watts at Different Blower Speeds							
	High		Medium-High		Medium-Low		Low	
	cfm	Watts	cfm	Watts	cfm	Watts	cfm	Watts
0.00	1555	630	1410	585	1190	520	1030	435
0.10	1515	605	1385	555	1190	485	1020	415
0.20	1470	580	1345	520	1170	455	1010	400
0.30	1410	555	1310	495	1155	440	1000	385
0.40	1350	535	1250	465	1120	410	980	360
0.50	1290	505	1205	450	1080	390	950	345
0.60	1220	485	1145	420	1020	365	905	320
0.70	1145	460	1080	400	975	345	860	300
0.80	1050	425	985	365	870	320	785	285
0.90	945	410	900	345	825	305	730	270

NOTES - All air data is measured external to unit without filter (not furnished - field provided).
Air volume based on bottom air return air. Actual air volume may vary on side return air applications.

G61MP-36B-070 PERFORMANCE (Less Filter)

External Static Pressure in. w.g.	Air Volume / Watts at Different Blower Speeds							
	High		Medium-High		Medium-Low		Low	
	cfm	Watts	cfm	Watts	cfm	Watts	cfm	Watts
0.00	1640	660	1415	575	1160	485	1005	410
0.10	1600	635	1395	550	1160	460	1000	385
0.20	1540	605	1370	525	1160	445	995	375
0.30	1495	580	1345	505	1145	425	990	365
0.40	1420	545	1275	480	1125	395	965	345
0.50	1360	525	1245	450	1080	375	945	325
0.60	1275	490	1165	410	1025	350	900	305
0.70	1170	465	1085	385	965	335	860	295
0.80	1080	440	1010	360	865	310	775	270
0.90	945	400	840	320	765	275	710	245

NOTES - All air data is measured external to unit without filter (not furnished - field provided).
Air volume based on bottom air return air. Actual air volume may vary on side return air applications.

G61MP-36B-071 PERFORMANCE (Less Filter)

External Static Pressure in. w.g.	Air Volume / Watts at Different Blower Speeds							
	High		Medium-High		Medium-Low		Low	
	cfm	Watts	cfm	Watts	cfm	Watts	cfm	Watts
0.00	1460	620	1215	570	965	445	785	375
0.10	1420	590	1215	545	990	425	815	365
0.20	1365	550	1195	505	980	410	810	350
0.30	1325	525	1170	490	980	390	820	335
0.40	1255	495	1155	455	945	365	795	320
0.50	1190	465	1080	425	915	345	785	305
0.60	1120	440	1050	395	865	320	755	285
0.70	1035	410	975	365	790	295	695	255
0.80	900	375	865	330	715	275	615	235
0.90	795	350	745	300	600	245	510	215

NOTES - All air data is measured external to unit without filter (not furnished - field provided).
Air volume based on bottom air return air. Actual air volume may vary on side return air applications.

G61MP-48C-090 PERFORMANCE (Less Filter)

External Static Pressure in. w.g.	Air Volume / Watts at Different Blower Speeds							
	High		Medium-High		Medium-Low		Low	
	cfm	Watts	cfm	Watts	cfm	Watts	cfm	Watts
0.00	2180	930	1835	790	1520	630	1280	510
0.10	2135	885	1825	750	1510	610	1275	495
0.20	2085	840	1810	720	1505	580	1270	475
0.30	2030	800	1775	685	1500	565	1265	460
0.40	1940	760	1735	650	1480	535	1250	440
0.50	1865	725	1660	600	1430	505	1215	425
0.60	1740	670	1590	575	1380	475	1175	410
0.70	1645	640	1475	520	1290	450	1105	375
0.80	1540	600	1340	465	1175	405	1020	355
0.90	1335	540	1170	440	1070	375	950	330

NOTES - All air data is measured external to unit without filter (not furnished - field provided).
Air volume based on bottom air return air. Actual air volume may vary on side return air applications.

G61MP-48C-110 PERFORMANCE (Less Filter)

External Static Pressure in. w.g.	Air Volume / Watts at Different Blower Speeds							
	High		Medium-High		Medium-Low		Low	
	cfm	Watts	cfm	Watts	cfm	Watts	cfm	Watts
0.00	2160	880	1880	755	1490	602	1235	485
0.10	2100	850	1855	730	1480	585	1230	475
0.20	2035	805	1815	690	1475	560	1225	460
0.30	1965	750	1755	650	1475	545	1220	445
0.40	1885	725	1715	625	1465	510	1215	430
0.50	1780	680	1630	580	1420	490	1150	400
0.60	1690	660	1550	550	1360	460	1110	380
0.70	1575	620	1410	505	1210	405	1035	350
0.80	1375	550	1230	450	1125	380	970	325
0.90	1225	520	1120	415	1050	365	885	310

NOTES - All air data is measured external to unit without filter (not furnished - field provided).
Air volume based on bottom air return air. Actual air volume may vary on side return air applications.

G61MP-60C-090 PERFORMANCE (Less Filter)

External Static Pressure in. w.g.	Air Volume / Watts at Different Blower Speeds															
	Bottom Return Air, Side Return Air with Optional RAB Return Air Base, Return Air from Both Sides or Return Air from Bottom and One Side.								Single Side Return Air - Air volumes in bold require field fabricated transition to accommodate 20 x 25 x 1 in. air filter in order to maintain proper air velocity.							
	High		Medium-High		Medium-Low		Low		High		Medium-High		Medium-Low		Low	
	cfm	Watts	cfm	Watts	cfm	Watts	cfm	Watts	cfm	Watts	cfm	Watts	cfm	Watts	cfm	Watts
0.00	2840	1450	2345	1105	1895	900	1515	700	2835	1495	2340	1155	1800	895	1440	695
0.10	2765	1415	2365	1080	1950	885	1580	700	2785	1475	2345	1135	1805	865	1515	690
0.20	2695	1385	2345	1050	1985	870	1620	695	2715	1435	2275	1080	1825	845	1560	685
0.30	2605	1335	2315	1030	1990	850	1645	690	2620	1380	2260	1035	1840	825	1600	680
0.40	2530	1300	2265	990	1990	825	1665	675	2550	1350	2230	1015	1845	815	1620	670
0.50	2420	1260	2210	955	1970	800	1675	665	2450	1305	2175	990	1850	790	1615	655
0.60	2330	1220	2145	925	1930	775	1665	650	2365	1270	2130	940	1830	775	1615	640
0.70	2250	1190	2050	885	1875	745	1645	630	2240	1205	2070	915	1815	760	1595	620
0.80	2135	1140	2000	865	1810	715	1620	615	2185	1190	1965	865	1775	745	1555	605
0.90	2030	1090	1885	830	1720	685	1560	590	2015	1150	1820	820	1690	715	1440	580

NOTES - All air data is measured external to unit without filter (not furnished - field provided).

G61MP-60C-091 PERFORMANCE (Less Filter)

External Static Pressure in. w.g.	Air Volume / Watts at Different Blower Speeds															
	Bottom Return Air, Side Return Air with Optional RAB Return Air Base, Return Air from Both Sides or Return Air from Bottom and One Side.								Single Side Return Air - Air volumes in bold require field fabricated transition to accommodate 20 x 25 x 1 in. air filter in order to maintain proper air velocity.							
	High		Medium-High		Medium-Low		Low		High		Medium-High		Medium-Low		Low	
	cfm	Watts	cfm	Watts	cfm	Watts	cfm	Watts	cfm	Watts	cfm	Watts	cfm	Watts	cfm	Watts
0.00	2320	1230	2240	960	1970	810	1505	690	2350	1275	2195	960	1920	830	1535	680
0.10	2250	1195	2155	910	1950	805	1610	665	2270	1240	2125	930	1910	800	1580	665
0.20	2185	1165	2080	890	1915	775	1630	660	2200	1190	2060	905	1875	775	1570	655
0.30	2060	1120	1965	835	1795	710	1590	620	2070	1135	1945	830	1830	725	1545	625
0.40	1995	1095	1890	805	1720	690	1535	600	1935	1095	1875	815	1750	705	1495	605
0.50	1920	1060	1860	790	1705	665	1540	580	1910	1070	1820	780	1715	670	1510	585
0.60	1800	1025	1750	755	1605	640	1485	560	1825	1050	1720	760	1635	645	1450	555
0.70	1710	1000	1625	735	1500	605	1380	535	1705	1025	1605	725	1485	615	1360	535
0.80	1600	975	1545	700	1455	585	1335	515	1605	995	1515	700	1440	585	1320	510
0.90	1475	940	1405	670	1305	555	1105	450	1460	950	1370	665	1285	555	1175	480

NOTES - All air data is measured external to unit without filter (not furnished - field provided).

Blower Performance Data

G61MP-60C-110 PERFORMANCE (Less Filter)

External Static Pressure in. w.g.	Air Volume / Watts at Different Blower Speeds Bottom Return Air, Side Return Air with Optional RAB Return Air Base, Return Air from Both Sides or Return Air from Bottom and One Side.								Air Volume / Watts at Different Blower Speeds Single Side Return Air - Air volumes in bold require field fabricated transition to accommodate 20 x 25 x 1 in. air filter in order to maintain proper air velocity.							
	High		Medium-High		Medium-Low		Low		High		Medium-High		Medium-Low		Low	
	cfm	Watts	cfm	Watts	cfm	Watts	cfm	Watts	cfm	Watts	cfm	Watts	cfm	Watts	cfm	Watts
0.00	2720	1385	2410	1090	2055	935	1620	710	2625	1350	2310	1080	1885	885	1515	700
0.10	2665	1355	2385	1075	2025	885	1730	735	2570	1330	2325	1060	1910	865	1575	700
0.20	2585	1315	2350	1015	2030	865	1680	690	2410	1305	2285	1035	1930	845	1620	690
0.30	2505	1275	2290	990	2025	840	1695	675	2425	1265	2230	990	1925	825	1635	675
0.40	2435	1250	2235	940	2030	830	1695	660	2335	1220	2175	950	1910	810	1640	660
0.50	2350	1205	2170	930	1975	790	1735	665	2270	1195	2120	935	1895	785	1640	640
0.60	2255	1185	2100	895	1915	765	1720	650	2170	1155	2045	885	1860	765	1630	630
0.70	2160	1150	2005	840	1865	730	1680	635	2110	1130	1950	855	1795	730	1590	610
0.80	2020	1090	1905	825	1810	710	1625	610	2035	1090	1885	820	1745	705	1540	580
0.90	1910	1050	1820	795	1705	675	1540	590	1900	1055	1760	780	1665	680	1470	565

NOTES - All air data is measured external to unit without filter (not furnished - field provided).

G61MP-60C-111 PERFORMANCE (Less Filter)

External Static Pressure in. w.g.	Air Volume / Watts at Different Blower Speeds Bottom Return Air, Side Return Air with Optional RAB Return Air Base, Return Air from Both Sides or Return Air from Bottom and One Side.								Air Volume / Watts at Different Blower Speeds Single Side Return Air - Air volumes in bold require field fabricated transition to accommodate 20 x 25 x 1 in. air filter in order to maintain proper air velocity.							
	High		Medium-High		Medium-Low		Low		High		Medium-High		Medium-Low		Low	
	cfm	Watts	cfm	Watts	cfm	Watts	cfm	Watts	cfm	Watts	cfm	Watts	cfm	Watts	cfm	Watts
0.00	2475	1305	2275	1010	1800	870	1425	680	2460	1355	2210	1045	1850	860	1435	670
0.10	2395	1260	2215	980	1850	850	1495	675	2395	1320	2170	1010	1850	830	1490	660
0.20	2340	1220	2165	945	1860	830	1535	665	2280	1270	2115	965	1875	810	1525	650
0.30	2255	1205	2085	915	1855	805	1545	655	2225	1250	2075	940	1835	785	1530	640
0.40	2165	1160	2000	880	1820	780	1540	645	2150	1210	2005	905	1800	760	1535	626
0.50	2055	1140	1920	845	1780	755	1535	625	2050	1155	1935	885	1760	740	1555	620
0.60	1995	1120	1845	825	1720	725	1485	605	1975	1140	1835	845	1660	705	1480	595
0.70	1880	1075	1760	800	1680	710	1470	595	1870	1110	1745	810	1620	685	1440	575
0.80	1795	1060	1640	755	1595	680	1415	570	1760	1065	1645	770	1510	655	1370	550
0.90	1680	1020	1530	725	1505	645	1345	550	1635	1025	1545	740	1415	620	1295	530

NOTES - All air data is measured external to unit without filter (not furnished - field provided).

G61MP-60D-135 PERFORMANCE (Less Filter)

External Static Pressure in. w.g.	Air Volume / Watts at Different Blower Speeds								Air Volume / Watts at Different Blower Speeds							
	Bottom Return Air, Side Return Air with Optional RAB Return Air Base, Return Air from Both Sides or Return Air from Bottom and One Side.								Single Side Return Air - Air volumes in bold require field fabricated transition to accommodate 20 x 25 x 1 in. air filter in order to maintain proper air velocity.							
	High		Medium-High		Medium-Low		Low		High		Medium-High		Medium-Low		Low	
cfm	Watts	cfm	Watts	cfm	Watts	cfm	Watts	cfm	Watts	cfm	Watts	cfm	Watts	cfm	Watts	
0.00	2730	1465	2425	1125	2055	915	1560	680	2665	1440	2325	1100	1865	890	1410	690
0.10	2670	1440	2400	1100	2065	890	1590	675	2615	1405	2310	1065	1915	865	1465	685
0.20	2600	1400	2365	1070	2045	865	1620	665	2530	1370	2280	1055	1925	850	1570	675
0.30	2525	1360	2315	1045	2035	845	1615	655	2470	1330	2235	1015	1920	825	1590	670
0.40	2445	1325	2260	1015	2020	820	1615	645	2380	1290	2175	985	1910	805	1590	655
0.50	2360	1280	2195	985	1960	790	1610	635	2310	1265	2120	965	1890	790	1595	645
0.60	2290	1255	2130	965	1900	755	1600	615	2200	1230	2055	935	1835	765	1580	630
0.70	2205	1220	2035	910	1825	730	1570	600	2120	1190	1970	900	1790	740	1545	605
0.80	2110	1195	1945	880	1765	710	1540	580	2025	1160	1890	875	1720	710	1515	590
0.90	1970	1120	1835	830	1680	690	1540	545	1930	1110	1800	835	1655	685	1440	570

NOTES - All air data is measured external to unit without filter (not furnished - field provided).

Heating Sequence of Operation

NOTE - The thermostat selection DIP switch on the control board is factory-set in the "TWO-STAGE" position.

Applications Using a Two-Stage Thermostat

A - Heating Sequence -- Control Board Thermostat Selection DIP switch in "Two-Stage" Position (Factory Setting)

- 1 - On a call for heat, thermostat first-stage contacts close sending a signal to the integrated control. The integrated control runs a self-diagnostic program and checks high temperature limit switches for normally closed contacts and pressure switches for normally open contacts. The combustion air inducer is energized at low speed and the humidifier terminal is energized.
- 2 - Once the control receives a signal that the low-fire pressure switch has closed, the combustion air inducer begins a 15-second pre-purge in low speed.
- 3 - After the pre-purge is complete, a 20-second initial ignitor warm-up period begins. The combustion air inducer continues to operate at low speed.
- 4 - After the 20-second warm-up period has ended, the gas valve is energized on low fire (first stage) and ignition occurs. At the same time, the control module sends a signal to begin an indoor blower 45-second ON-delay. When the delay ends, the indoor blower motor is energized on the low fire heating speed. The furnace will continue this operation as long as the thermostat has a first-stage heating demand.
- 5 - If second-stage heat is required, the thermostat second-stage heat contacts close and send a signal to the integrated control. The integrated control initiates a 30-second second-stage recognition delay.
- 6 - At the end of the recognition delay, the integrated control energizes the combustion air inducer at high speed. The control also checks the high-fire (second stage) pressure switch to make sure it is closed. Once the control receives a signal that the high-fire pressure switch is closed, the high-fire (second stage) gas valve is energized and the indoor blower motor is energized for operation at the high-fire heating speed.
- 7 - When the demand for high-fire (second stage) heat is satisfied, the combustion air inducer is switched to the low-fire heating speed and the high-fire (second stage) gas valve is de-energized. The low-fire (first stage) gas valve continues operation. The indoor blower motor is switched to the low-fire heating speed.
- 8 - When the thermostat demand for low-fire (first stage) heat is satisfied, the gas valve is de-energized and the field-selected indoor blower off delay begins. The combustion air inducer begins a 5-second post-purge period.
- 9 - When the combustion air post-purge period is complete, the inducer and humidifier terminal are de-energized. The indoor blower is de-energized at the end of the off delay.

Applications Using A Single-Stage Thermostat

B - Heating Sequence -- Control Board Thermostat Selection DIP switch in "Single-Stage" Position

NOTE - In these applications, two-stage heat will be initiated by the integrated control if heating demand has not been satisfied after the field adjustable period (10 or 15 minutes).

- 1 - On a call for heat, thermostat first-stage contacts close sending a signal to the integrated control. The integrated control runs a self-diagnostic program and checks high temperature limit switches for normally closed contacts and pressure switches for normally open contacts. The combustion air inducer is energized at low speed and the humidifier terminal is energized.
- 2 - Once the control receives a signal that the low-fire pressure switch has closed, the combustion air inducer begins a 15-second pre-purge in low speed.
- 3 - After the pre-purge is complete, a 20-second initial ignitor warm-up period begins. The combustion air inducer continues to operate at low speed.
- 4 - After the 20-second warm-up period has ended, the gas valve is energized on low fire (first stage) and ignition occurs. At the same time, the control module sends a signal to begin an indoor blower 45-second ON-delay. When the delay ends, the indoor blower motor is energized on the low-fire heating speed. The integrated control also initiates a second-stage on delay (factory-set at 10 minutes; adjustable to 15 minutes).
- 5 - If the heating demand continues beyond the second-stage on delay, the integrated control energizes the combustion air inducer at high speed. The control also checks the high-fire (second stage) pressure switch to make sure it is closed. Once the control receives a signal the high-fire pressure switch is closed, the high-fire (second stage) gas valve is energized and the indoor blower motor is energized for operation at the high-fire heating speed.
- 6 - When the thermostat heating demand is satisfied, the combustion air inducer begins a 5-second post-purge. The field-selected indoor blower off delay begins.
- 7 - When the combustion air post-purge period is complete, the inducer and humidifier terminal are de-energized. The indoor blower is de-energized at the end of the off delay.

Service

⚠ WARNING

**ELECTRICAL SHOCK, FIRE,
OR EXPLOSION HAZARD.**

Failure to follow safety warnings exactly could result in dangerous operation, serious injury, death or property damage.

Improper servicing could result in dangerous operation, serious injury, death, or property damage.

Before servicing, disconnect all electrical power to furnace.

When servicing controls, label all wires prior to disconnecting. Take care to reconnect wires correctly. Verify proper operation after servicing.

At the beginning of each heating season, system should be checked as follows by a qualified service technician:

Blower

Check the blower wheel for debris and clean if necessary. The blower motors are prelubricated for extended bearing life. No further lubrication is needed.

⚠ WARNING

The blower access panel must be securely in place when the blower and burners are operating. Gas fumes, which could contain carbon monoxide, can be drawn into living space resulting in personal injury or death.

Filters

All G61MP filters are installed external to the unit. Filters should be inspected monthly. Clean or replace the filters when necessary to ensure proper furnace operation. Table 3 lists recommended filter sizes.

Exhaust and air intake pipes

Check the exhaust and air intake pipes and all connections for tightness and to make sure there is no blockage.

NOTE - After any heavy snow, ice or frozen fog event the furnace vent pipes may become restricted. Always check the vent system and remove any snow or ice that may be obstructing the plastic intake or exhaust pipes.

Electrical

- 1 - Check all wiring for loose connections.
- 2 - Check for the correct voltage at the furnace (furnace operating).
- 3 - Check amp-draw on the blower motor.
Motor Nameplate _____ Actual _____

Winterizing and Condensate Trap Care

- 1 - Turn off power to the unit.
- 2 - Have a shallow pan ready to empty condensate water.

- 3 - Remove the drain plug from the condensate trap and empty water. Inspect the trap then reinstall the drain plug.

Cleaning Heat Exchanger

If cleaning the heat exchanger becomes necessary, follow the below procedures and refer to figure 1 when disassembling unit. Use papers or protective covering in front of furnace while removing heat exchanger assembly.

- 1 - Turn off electrical and gas supplies to the furnace.
- 2 - Remove the upper and lower furnace access panels.
- 3 - Mark all gas valve wires and disconnect them from valve.
- 4 - Remove gas supply line connected to gas valve. Remove gas valve/manifold assembly.
- 5 - Remove sensor wire from sensor. Disconnect 2-pin plug from the ignitor.
- 6 - Disconnect wires from flame roll-out switches.
- 7 - Remove burner box cover and remove four burner box screws at the vestibule panel and remove burner box. Set burner box assembly aside.

NOTE - G61MP-135 units are secured to the vestibule panel by two additional screws. These screws must be removed for servicing; however it is not necessary to replace the screws.

NOTE - If necessary, clean burners at this time. Follow procedures outlined in Burner Cleaning section.

- 8 - Loosen three clamps and remove flexible exhaust tee.
- 9 - Remove 3/8 inch rubber cap from condensate drain plug and drain. Replace cap after draining.
- 10 - Disconnect condensate drain line from the condensate trap. Remove condensate trap (it may be necessary to cut drain pipe). Remove screws that secure condensate collars to either side of the furnace and remove collars. Remove drain tubes from cold end header collector box.
- 11 - Disconnect condensate drain tubing from flue collar. Remove screws that secure both flue collars into place. Remove flue collars. It may be necessary to cut the exiting exhaust pipe for removal of the fittings.
- 12 - Mark and disconnect all combustion air pressure tubing from cold end header collector box.
- 13 - Mark and remove wires from pressure switches. Remove pressure switches. Keep tubing attached to pressure switches.
- 14 - Disconnect the 3-pin plug from the combustion air inducer. Disconnect the two wires to the backup secondary limit, if applicable. Remove four screws which secure combustion air inducer to collector box. Remove combustion air inducer assembly. Remove ground wire from vest panel.
- 15 - Remove electrical junction box from the side of the furnace.
- 16 - Mark and disconnect any remaining wiring to heating compartment components. Disengage strain relief bushing and pull wiring and bushing through the hole in the blower deck.

- 17 - Remove the primary limit from the vestibule panel.
 - 18 - Remove two screws from the front cabinet flange at the blower deck. Spread cabinet sides slightly to allow clearance for removal of heat exchanger.
 - 19 - Remove screws along vestibule sides and bottom which secure vestibule panel and heat exchanger assembly to cabinet. Remove two screws from blower rail which secure bottom heat exchanger flange. Remove heat exchanger from furnace cabinet.
 - 20 - Back wash heat exchanger with soapy water solution or steam. **If steam is used it must be below 275°F (135°C) .**
 - 21 - Thoroughly rinse and drain the heat exchanger. Soap solutions can be corrosive. Take care to rinse entire assembly.
 - 22 - Reinstall heat exchanger into cabinet making sure that the clamshells of the heat exchanger assembly are resting on the support located at the rear of the cabinet. Remove the indoor blower to view this area through the blower opening.
 - 23 - Re-secure the supporting screws along the vestibule sides and bottom to the cabinet.
 - 24 - Reinstall cabinet screws on front flange at blower deck.
 - 25 - Reinstall the primary limit on the vestibule panel.
 - 26 - Route heating component wiring through hole in blower deck and reinsert strain relief bushing.
 - 27 - Reinstall electrical junction box.
 - 28 - Reinstall the combustion air inducer. Reconnect the 3-pin plug to the wire harness. Reconnect the two wires to the backup secondary limit, if applicable.
 - 29 - Reinstall pressure switches and reconnect pressure switch wiring.
 - 30 - Carefully connect combustion air pressure switch hosing from pressure switches to proper stubs on cold end header collector box.
 - 31 - Reinstall condensate collars on each side of the furnace. Reconnect drain tubing to collector box.
 - 32 - Reinstall condensate trap on same side as exhaust pipe. Reconnect condensate drain line to the condensate trap.
 - 33 - Use securing screws to reinstall flue collars to either side of the furnace. Reconnect exhaust piping and exhaust drain tubing.
 - 34 - Replace flexible exhaust tee on combustion air inducer and flue collars. Secure using three existing hose clamps.
 - 35 - Reinstall burner box assembly in vestibule area.
 - 36 - Reconnect flame roll-out switch wires.
 - 37 - Reconnect sensor wire and reconnect 2-pin plug from ignitor.
 - 38 - Secure burner box assembly to vestibule panel using four existing screws. **Make sure burners line up in center of burner ports.**
 - 39 - Reinstall gas valve manifold assembly. Reconnect gas supply line to gas valve.
 - 40 - Reinstall burner box cover.
 - 41 - Reconnect wires to gas valve.
 - 42 - Replace the blower compartment access panel.
 - 43 - Refer to instruction on verifying gas and electrical connections when re-establishing supplies.
 - 44 - Follow lighting instructions to light and operate furnace for 5 minutes to ensure that heat exchanger is clean and dry and that furnace is operating properly.
 - 45 - Replace heating compartment access panel.
- Cleaning the Burner Assembly**
- 1 - Turn off electrical and gas power supplies to furnace. Remove upper and lower furnace access panels.
 - 2 - Mark all gas valve wires and disconnect them from the valve.
 - 3 - Disconnect the gas supply line from the gas valve. Remove gas valve/manifold assembly.
 - 4 - Mark and disconnect sensor wire from the sensor. Disconnect 2-pin plug from the ignitor at the burner box.
 - 5 - Remove burner box cover and remove four screws which secure burner box assembly to vest panel. Remove burner box from the unit.
***NOTE** - G61MP-135 units are secured to the vestibule panel by two additional screws. These screws must be removed for servicing; however it is not necessary to replace the screws.*
 - 6 - Use the soft brush attachment on a vacuum cleaner to gently clean the face of the burners. Visually inspect the inside of the burners and crossovers for any blockage caused by foreign matter. Remove any blockage.
 - 7 - Reconnect the sensor wire and reconnect the 2-pin plug to the ignitor wiring harness.
 - 8 - Reinstall the burner box assembly using the existing four screws. Make sure that the burners line up in the center of the burner ports.
 - 9 - Reinstall the gas valve manifold assembly. Reconnect the gas supply line to the gas valve. Reinstall the burner box cover.
 - 10 - Reconnect the gas valve wires to the gas valve.
 - 11 - Replace the blower compartment access panel.
 - 12 - Refer to instruction on verifying gas and electrical connections when re-establishing supplies.
 - 13 - Follow lighting instructions to light and operate furnace for 5 minutes to ensure that heat exchanger is clean and dry and that furnace is operating properly.
 - 14 - Replace heating compartment access panel.

Planned Service

A service technician should check the following items during an annual inspection. Power to the unit must be shut off for safety.

Fresh air grilles and louvers (on the unit and in the room where the furnace is installed) - Must be open and unobstructed to provide combustion air.

Burners - Must be inspected for rust, dirt, or signs of water.

Vent pipe - Must be inspected for signs of water, damaged, cracked or sagging pipe, or disconnected joints.

Unit appearance - Must be inspected for rust, dirt, signs of water, burnt or damaged wires, or components.

Blower access door - Must be properly in place and provide a seal between the return air and the room where the furnace is installed.

Return air duct - Must be properly attached and provide an air seal to the unit.

Operating performance - Unit must be observed during operation to monitor proper performance of the unit and the vent system.

Combustion gases - Flue products must be analyzed and compared to the unit specifications.

Problems detected during the inspection may make it necessary to temporarily shut down the furnace until the items can be repaired or replaced.

Instruct the homeowners to pay attention to their furnace. Situations can arise between annual furnace inspections that may result in unsafe operation. For instance, items innocently stored next to the furnace may obstruct the combustion air supply. This could cause incomplete combustion and the production of carbon monoxide gas.

Ignition Control Board Diagnostic Codes

FLASH CODE (X + Y)	STATUS / ERROR DESCRIPTION
FLASH CODE DESCRIPTIONS	
Pulse	A 1/4 second flash followed by four seconds of off time.
Heartbeat	Constant 1/2 second bright and 1/2 second dim cycles.
X + Y	LED flashes X times at 2Hz, remains off for two seconds, flashes Y times at 2Hz, remains off for four seconds, then repeats.
Pulse	Power on - Standby.
Heartbeat	Normal operation - signaled when heating demand initiated at thermostat.
FLAME CODES	
1 + 2	Low flame current -- run mode.
1 + 3	Flame sensed out of sequence -- flame still present.
PRESSURE SWITCH CODES	
2 + 3	Low pressure switch failed open.
2 + 4	Low pressure switch failed closed.
2 + 5	High pressure switch failed open.
2 + 6	High pressure switch failed closed.
2 + 7	Low pressure switch opened during ignition trial or heating demand.
LIMIT CODE	
3 + 1	Limit switch open.
WATCHGUARD CODES	
4 + 1	Watchguard -- Exceeded maximum number of retries.
4 + 2	Watchguard -- Exceeded maximum number of retries or last retry was due to pressure switch opening.
4 + 3	Watchguard -- Exceeded maximum number of retries or last retry was due to flame failure.
4 + 5	Watchguard -- Limit remained open longer than three minutes.
4 + 6	Watchguard -- Flame sensed out of sequence; flame signal gone.
4 + 7	Ignitor circuit fault -- Failed ignitor or triggering circuitry.
4 + 8	Low line voltage.
HARD LOCKOUT CODES	
5 + 1	Hard lockout -- Rollout circuit open or previously opened.
5 + 2	Control failed self check, internal error (control will restart if error recovers).
5 + 3	No Earth ground (control will restart if error recovers).
5 + 4	Reversed line voltage polarity (control will restart if the error recovers).
5 + 6	Low secondary (24VAC) voltage.

Error Code Storage

The ignition control stores the last ten error codes in memory. The codes are retained in case of power loss.

Error Code Review

- 1 - Short R (2) to (1). Within 1/2 second, the STATUS LED will stay lit continuously to indicate that the short was sensed.
- 2 - Continue to hold the short between R (2) to (1). After 5 seconds, STATUS LED will go from being continuously lit to off. This indicates that error code review is pending.
- 3 - Remove R (2) to (1) short within ten seconds of STATUS LED turning off. This activates error code review.
- 4 - Last ten error codes will be flashed on the STATUS LED.

- 5 - After final error code is indicated, STATUS LED will flash to indicate normal operation.

Clearing Error Codes

- 1 - Short R (2) to (1). Within 1/2 second, the STATUS LED will stay lit continuously to indicate that the short was sensed.
- 2 - Continue to hold the short between R (2) to (1). After 5 seconds, STATUS LED will go from being continuously lit to off.
- 3 - Continue to hold the short between R (2) to (1) beyond ten seconds after STATUS LED has turned off. STATUS LED will turn on, indicating that error codes have been cleared.
- 4 - Remove R (2) to (1) short. STATUS LED will flash to indicate normal operation.

Troubleshooting: Heating Sequence of Operation

HEATING SEQUENCE OF OPERATION NORMAL AND ABNORMAL HEATING MODE

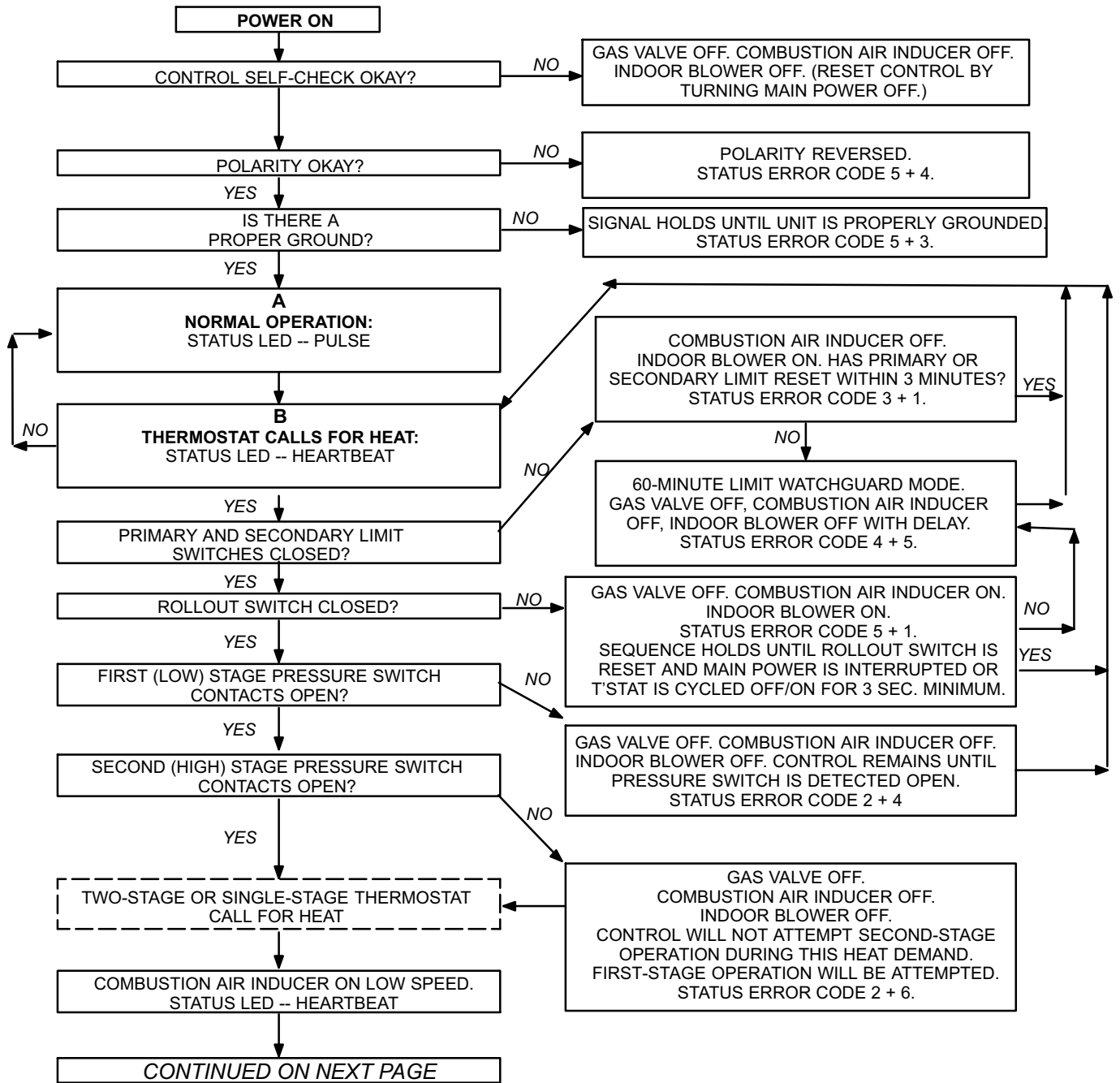

Troubleshooting: Heating Sequence of Operation (Continued)

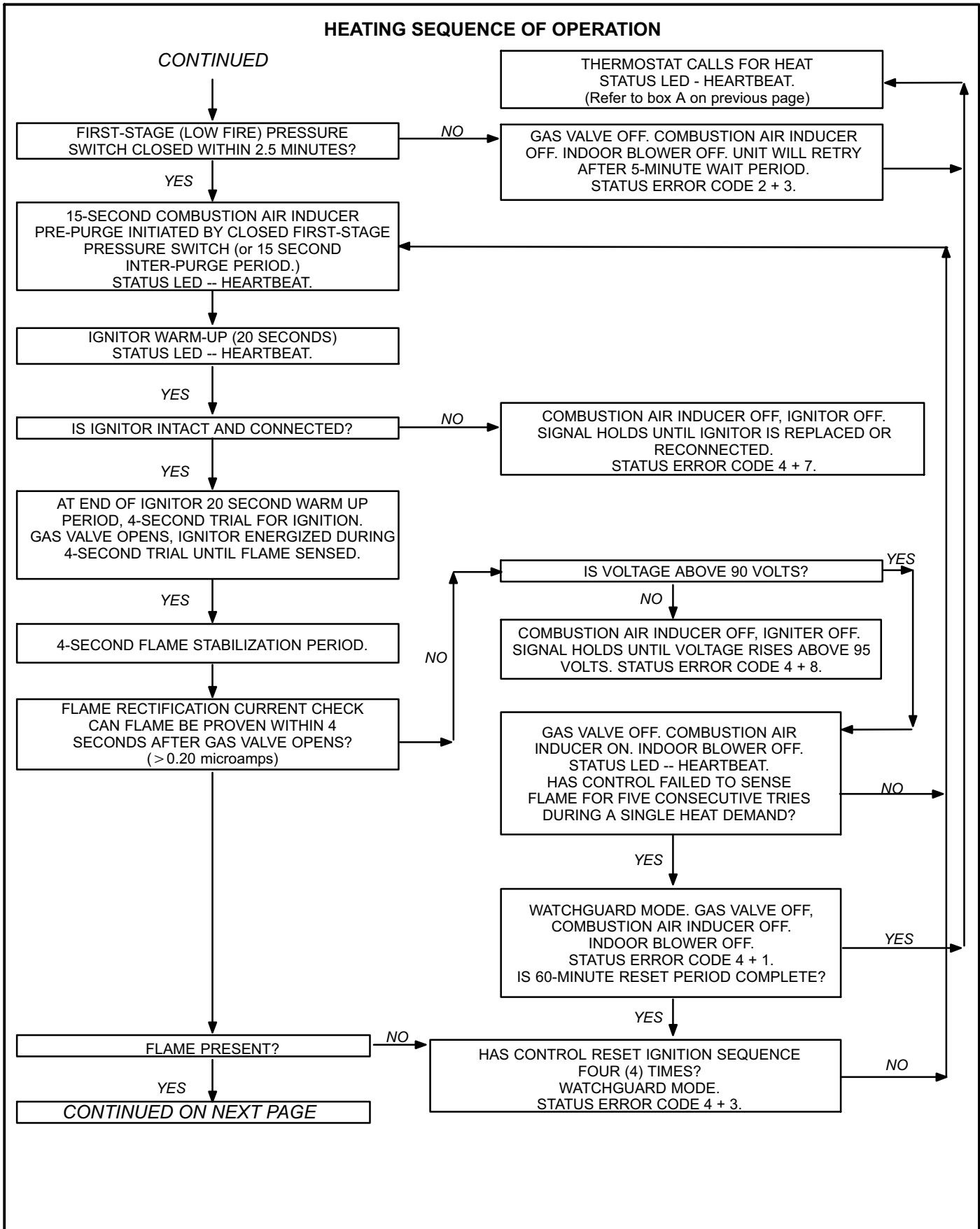

Troubleshooting: Heating Sequence of Operation (Continued)

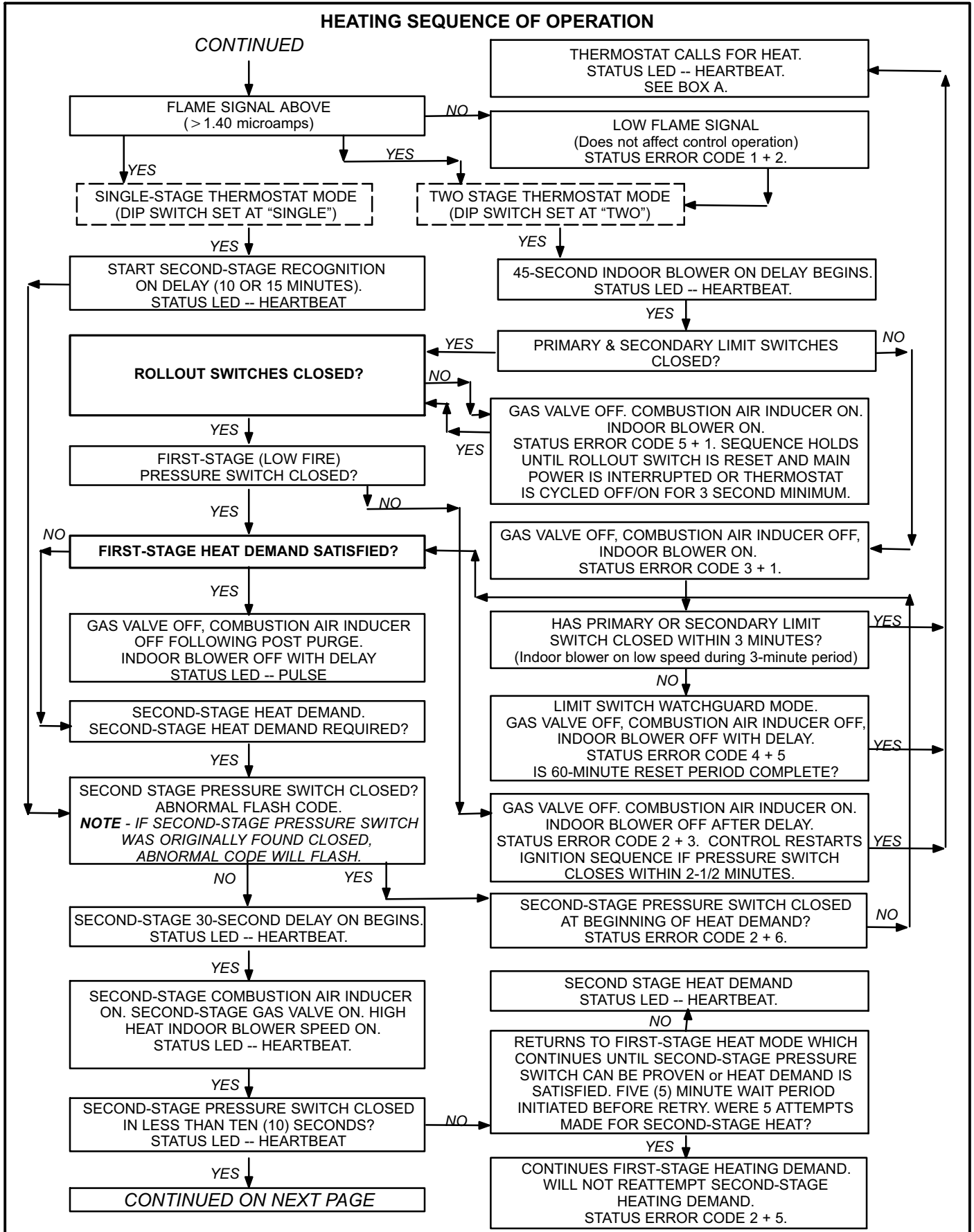

Troubleshooting: Heating Sequence of Operation (Continued)

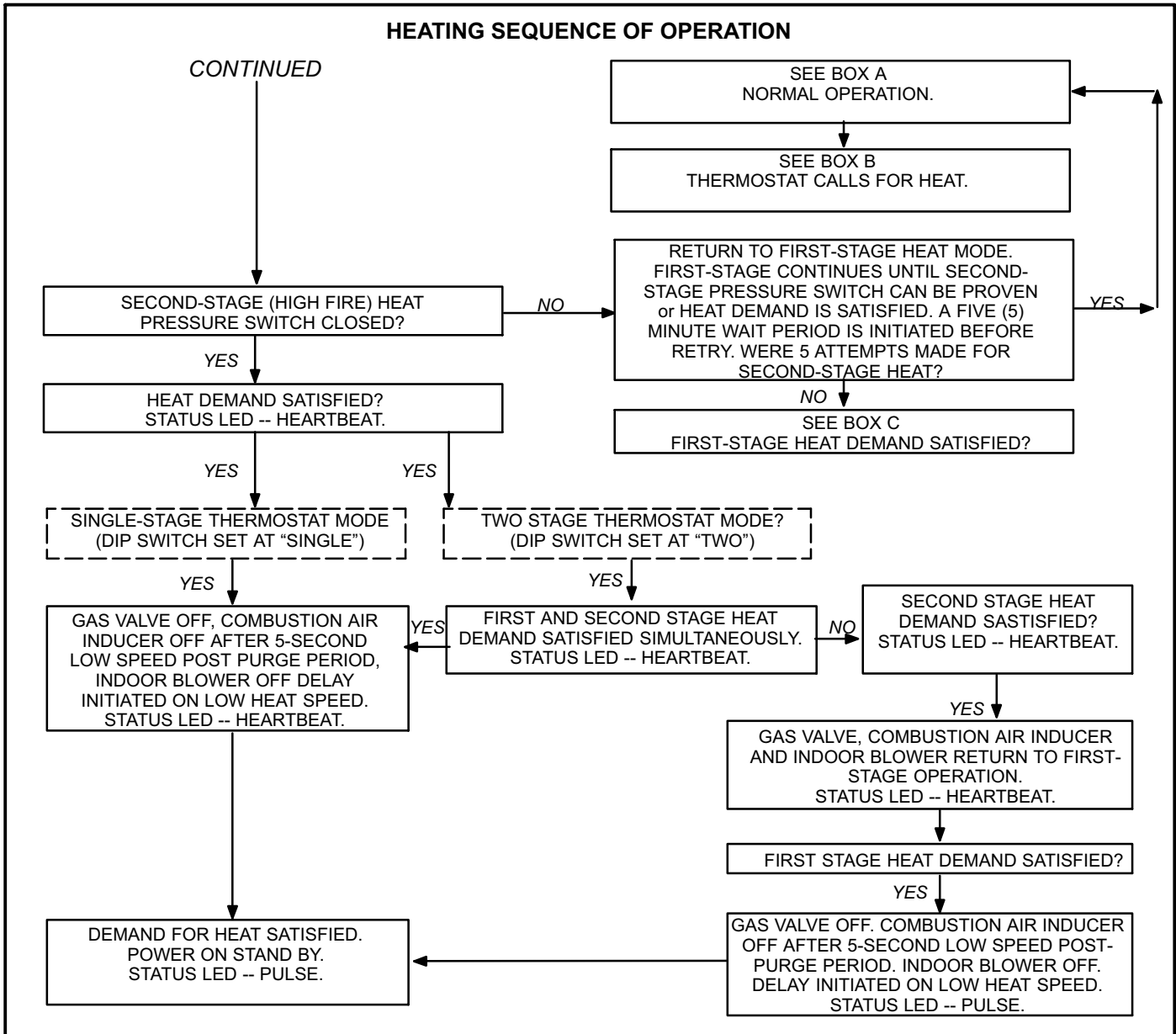

Troubleshooting: Cooling Sequence of Operation

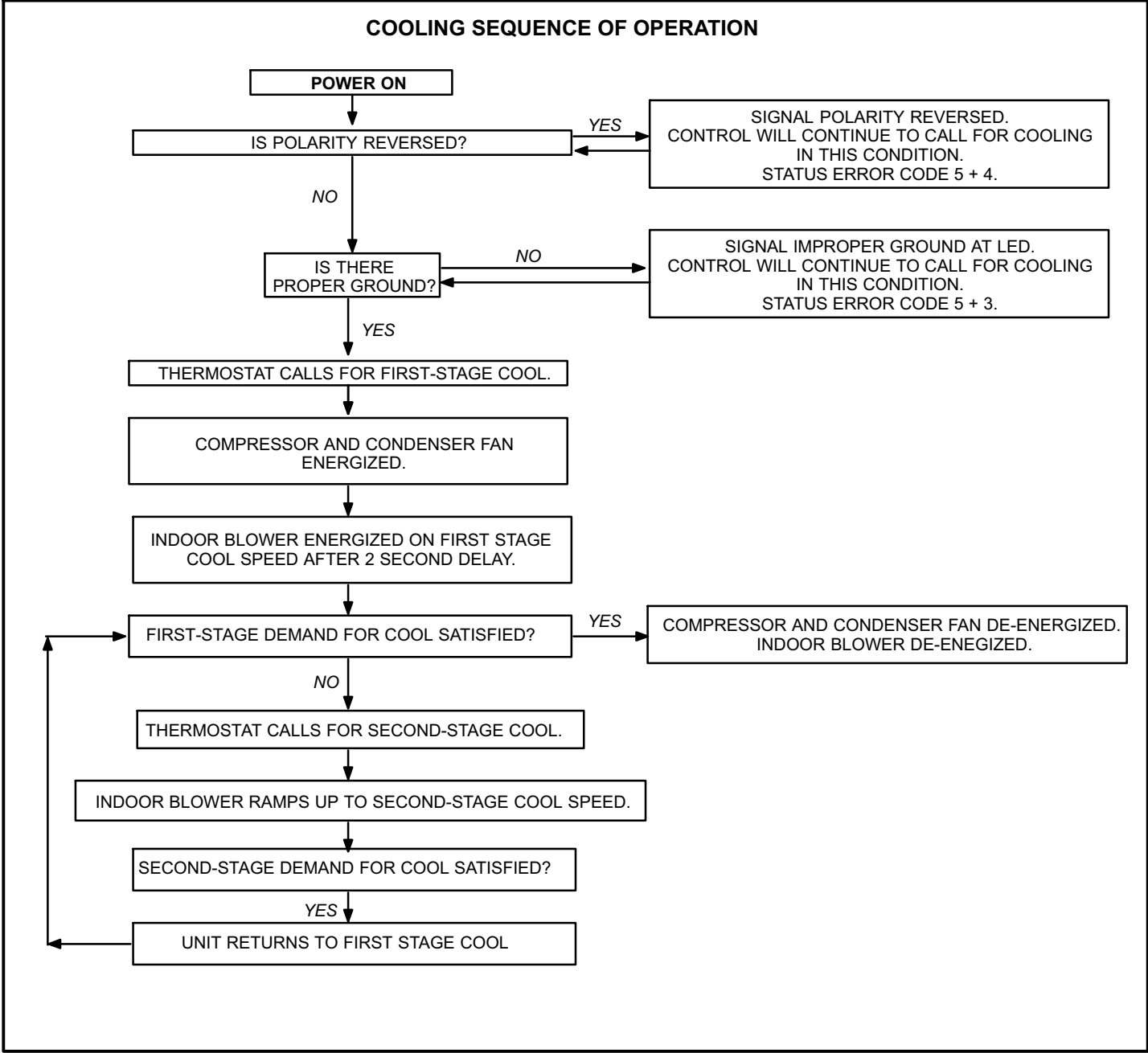

Troubleshooting: Continuous Fan Sequence of Operation

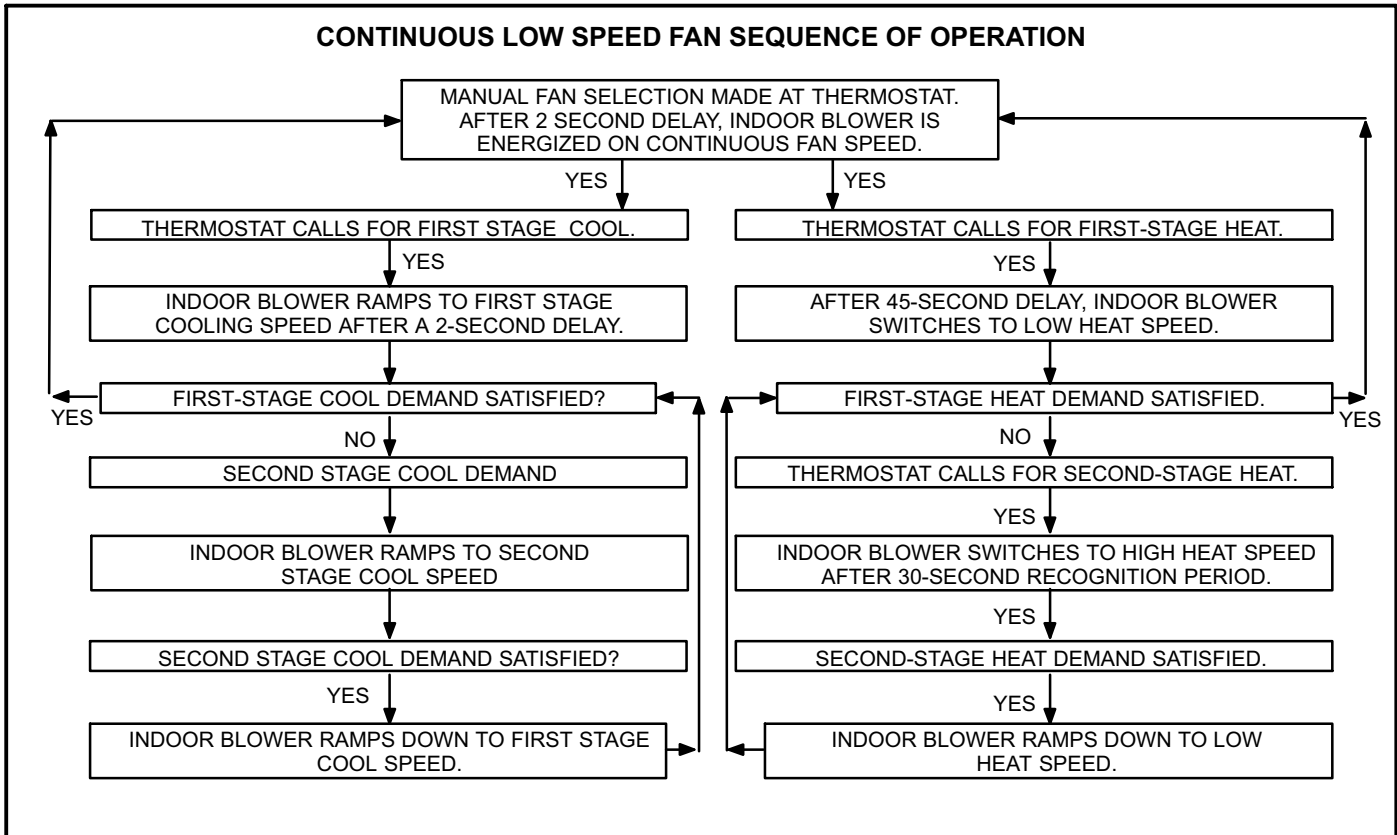

Repair Parts List

The following repair parts are available through Lennox dealers. When ordering parts, include the complete furnace model number listed on the CSA nameplate -- Example: G61MP-36B-045-1. **All service must be performed by a licensed professional installer (or equivalent), service agency, or gas supplier.**

Cabinet Parts

- Upper access panel
- Blower access panel
- Top Cap

Control Panel Parts

- Transformer
- Two-stage integrated control board
- Door interlock switch
- Circuit Breaker

Blower Parts

- Blower wheel
- Motor
- Motor mounting frame
- Motor capacitor
- Blower housing cutoff plate

Heating Parts

- Flame Sensor
- Heat exchanger assembly
- Gas manifold
- Combustion air inducer
- Gas valve
- Main burner cluster
- Main burner orifices
- Pressure switches
- Ignitor
- Primary limit control
- Secondary limit control
- Flame rollout switches
- Combustion air inducer auxiliary limit

Vent Pipe Sizing Worksheet

Step 1	Proposed vent pipe size : _____	Equivalent Feet
Step 2	Termination kit catalog number : _____ Vent pipe equivalency value from table 5 : _____	
Step 3	Total number of 90° elbows required (indoors and outdoors) _____ X 5 = _____ equivalent feet of pipe	
Step 4	Total number of 45° elbows required (indoors and outdoors) _____ X 2.5 = _____ equivalent feet of pipe	
Step 5	Linear feet of straight pipe required : _____	
Step 6	Add equivalent feet of vent pipe listed in steps 2 through 5.	TOTAL

If the total is equal to, or less than, the allowable maximum given in table 6, the proposed pipe size is acceptable. If the total exceeds the maximum allowed vent pipe length, repeat the process above using the next larger diameter pipe until an acceptable total is achieved.

NOTE - In Direct Vent systems, total the equivalent length of either the exhaust OR intake piping run, depending upon which will be LONGER. Intake and exhaust pipe diameter must be the same size and must be terminated in the same pressure zone. Intake and exhaust pipe should be roughly the same length.

G61MP Start-Up & Performance Check List

Job Name _____ Job No. _____ Date _____
 Job Location _____ City _____ State _____
 Installer _____ City _____ State _____
 Unit Model No. _____ Technician _____
 Serial No. _____

Heating Section

Electrical Connections Tight?
 Line Voltage _____ Blower Motor H.P. _____
 Blower Motor Amps _____ Gas Piping Connections
 Tight & Leak-Tested?
 Fuel Type: Natural Gas? LP/Propane Gas?
 Furnace Btu Input (High fire) _____ - Line Pressure _____
 Low Fire Manifold Pressure _____ w.c. - Nat.: _____ w.c. - LP/Propane
 High Fire Manifold Pressure _____ w.c. - Nat.: _____ w.c. - LP/Propane
 Flue Connections Tight? Proper Draft?
 Combustion Gas Tested (high fire and low fire)? CO₂ CO
 Blower ON delay confirmed? External Static Pressure? _____
 (45 Seconds Fixed On) (0.5 maximum)
 Blower OFF Delay Setting (60, 90, 120 or 180)? _____ Temperature Rise _____
 Filter Clean & Secure?

Thermostat

Heat Anticipator Setting? _____ Thermostat Level?

Requirements for Commonwealth of Massachusetts

Modifications to NFPA-54, Chapter 10

Revise NFPA-54 section 10.8.3 to add the following requirements:

For all side wall, horizontally vented, gas-fueled equipment installed in every dwelling, building or structure used in whole or in part for residential purposes, including those owned or operated by the Commonwealth and where the side wall exhaust vent termination is less than seven (7) feet above the finished grade in the area of the venting, including but not limited to decks and porches, the following requirements shall be satisfied:

- 1 - **INSTALLATION OF CARBON MONOXIDE DETECTORS.** At the time of installation of the side wall, horizontally vented, gas-fueled equipment, the installing plumber or gasfitter shall observe that a hard-wired carbon monoxide detector with an alarm and battery backup is installed on the floor level where the gas equipment is to be installed. In addition, the installing plumber or gasfitter shall observe that a battery-operated or hard-wired carbon monoxide detector with an alarm is installed on each additional level of the dwelling, building or structure served by the side wall, horizontally vented, gas-fueled equipment. It shall be the responsibility of the property owner to secure the services of qualified licensed professionals for the installation of hard-wired carbon monoxide detectors.
 - a - In the event that the side wall, horizontally vented, gas-fueled equipment is installed in a crawl space or an attic, the hard-wired carbon monoxide detector with alarm and battery back-up may be installed on the next adjacent floor level.
 - b - In the event that the requirements of this subdivision cannot be met at the time of completion of installation, the owner shall have a period of thirty (30) days to comply with the above requirements; provided, however, that during said thirty (30) day period, a battery-operated carbon monoxide detector with an alarm shall be installed.
- 2 - **APPROVED CARBON MONOXIDE DETECTORS.** Each carbon monoxide detector as required in accordance with the above provisions shall comply with NFPA 720 and be ANSI/UL 2034 listed and IAS certified.
- 3 - **SIGNAGE.** A metal or plastic identification plate shall be permanently mounted to the exterior of the building at a minimum height of eight (8) feet above grade directly in line with the exhaust vent terminal for the horizontally vented, gas-fueled heating appliance or equipment. The sign shall read, in print size no less than one-half (1/2) inch in size, "GAS VENT DIRECTLY BELOW. KEEP CLEAR OF ALL OBSTRUCTIONS."

- 4 - **INSPECTION.** The state or local gas inspector of the side wall, horizontally vented, gas-fueled equipment shall not approve the installation unless, upon inspection, the inspector observes carbon monoxide detectors and signage installed in accordance with the provisions of 248 CMR 5.08(2)(a) 1 through 4.

EXEMPTIONS: The following equipment is exempt from 24 CMR 5.08(2)(a) 1 through 4:

- 1 - The equipment listed in Chapter 10 entitled "Equipment Not Required to Be Vented" in the most current edition of NFPA 54 as adopted by the Board; and
- 2 - Product Approved side wall, horizontally vented, gas-fueled equipment installed in a room or structure separate from the dwelling, building or structure used in whole or in part for residential purposes.

MANUFACTURER REQUIREMENTS - GAS EQUIPMENT VENTING SYSTEM PROVIDED.

When the manufacturer of Product Approved side wall, horizontally vented, gas-fueled equipment provides a venting system design or venting system components with the equipment, the instructions provided by the manufacturer for installation of the equipment and the venting system shall include:

- 1 - Detailed instructions for the installation of the venting system design or the venting system components: and
- 2 - A complete parts list for the venting system design or venting system.

MANUFACTURER REQUIREMENTS - GAS EQUIPMENT VENTING SYSTEM NOT PROVIDED.

When the manufacturer of Product Approved side wall, horizontally vented, gas-fueled equipment does not provide the parts for venting the flue gases, but identifies "special venting systems," the following requirements shall be satisfied by the manufacturer:

- 1 - The referenced "special venting system" instructions shall be included with the appliance or equipment installation instructions; and
- 2 - The "special venting systems" shall be Product Approved by the Board, and the instructions for that system shall include a parts list and detailed installation instructions.

A copy of all installation instructions for all Product Approved side wall, horizontally vented, gas-fueled equipment, all venting instructions, all parts lists for venting instructions, and/or all venting design instructions shall remain with the appliance or equipment at the completion of the installation.

Free Manuals Download Website

<http://myh66.com>

<http://usermanuals.us>

<http://www.somanuals.com>

<http://www.4manuals.cc>

<http://www.manual-lib.com>

<http://www.404manual.com>

<http://www.luxmanual.com>

<http://aubethermostatmanual.com>

Golf course search by state

<http://golfingnear.com>

Email search by domain

<http://emailbydomain.com>

Auto manuals search

<http://auto.somanuals.com>

TV manuals search

<http://tv.somanuals.com>