



website <http://www.lgservice.com>

LG

LG

Room Air Conditioner

SERVICE MANUAL

**MODELS: LAN181CNW(ASNC183VML3)
LAU181CNW(ASUC183VML3)
LA180CPI (ASNC183VML3)
LA180CPO (ASUC183VML3)**

CAUTION

- BEFORE SERVICING THE UNIT, READ THE SAFETY PRECAUTIONS IN THIS MANUAL.
- ONLY FOR AUTHORIZED SERVICE PERSONNEL.

TABLE OF CONTENTS

Details of 2006 LG Model Name	3
Safety Precautions	4
Functions	10
Product References	12
Dimensions	13
Refrigeration Cycle Diagram	15
Wiring Diagram	16
Operation Details	17
Display Function	23
Self-diagnosis Function	23
Introduction	24
Installation	25
Operation	42
Disassembly of the parts (Indoor Unit)	43
2-way, 3-way Valve	46
Cycle Troubleshooting Guide	54
Electronic Control Device	64
Schematic Diagram	67
Exploded View and Replacement Parts List	69

Details of 2006 LG Model Name

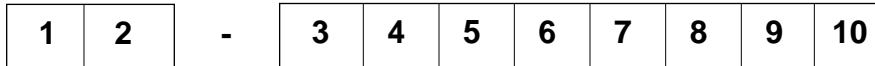

Code	Type	Code of Model	Meaning																								
1	Producing Center/ Refrigerant	A~Z	L: ChangWon R22, A: ChangWon R410A, C: ChangWon R407C																								
2	Type of Air conditioner	A~Z	S: Split Type Air conditioner																								
3	Cooling/Heating	A~Z	C: C/O, H: H/P, X: C/O + E/H, Z: H/P + E/H																								
4,5	Capacity(Btu/h)	1~9	Cooling/Heating Capacity Ex. "09" → 9,000Btu/h																								
6	Electric Range	1~9	Electric Standard <table style="width: 100%; border: none;"> <tr> <td style="width: 50%;">1 → 115V/60Hz</td> <td style="width: 50%;">6 → 220~240V/50Hz</td> </tr> <tr> <td>2 → 220V/60Hz</td> <td>7 → 110V, 50/60Hz</td> </tr> <tr> <td>3 → 208~230V/60Hz</td> <td>8 → 380~415V/50Hz</td> </tr> <tr> <td>5 → 200~220V/50Hz</td> <td>9 → 380~415V/60Hz</td> </tr> </table>	1 → 115V/60Hz	6 → 220~240V/50Hz	2 → 220V/60Hz	7 → 110V, 50/60Hz	3 → 208~230V/60Hz	8 → 380~415V/50Hz	5 → 200~220V/50Hz	9 → 380~415V/60Hz																
1 → 115V/60Hz	6 → 220~240V/50Hz																										
2 → 220V/60Hz	7 → 110V, 50/60Hz																										
3 → 208~230V/60Hz	8 → 380~415V/50Hz																										
5 → 200~220V/50Hz	9 → 380~415V/60Hz																										
7	Chassis	A~Z	Name of tool of unit																								
8	Color	A~Z	R: Mirror B: Blue N: Walnut W: White M: Metal C: Cherry																								
9	Function	A~Z	<table border="1" style="width: 100%; border-collapse: collapse;"> <tr><td>Basic</td><td>A</td></tr> <tr><td>Basic + 4Way</td><td>B</td></tr> <tr><td>Plasma Filter</td><td>C</td></tr> <tr><td>Plasma Filter + 4Way</td><td>D</td></tr> <tr><td>Tele + LED + 4Way</td><td>E</td></tr> <tr><td>Tele + LCD + Plasma F + 4Way</td><td>F</td></tr> <tr><td>Tele Multi + LCD + Plasma F + 4Way</td><td>G</td></tr> <tr><td>Low A + Plasma F</td><td>H</td></tr> <tr><td>Low A + Plasma F + 4Way</td><td>J</td></tr> <tr><td>Plasma F + 4Way + Oxygen Generator</td><td>K</td></tr> <tr><td>A/change + Plasma F</td><td>L</td></tr> <tr><td>A/change + Plasma F + 4Way</td><td>M</td></tr> </table>	Basic	A	Basic + 4Way	B	Plasma Filter	C	Plasma Filter + 4Way	D	Tele + LED + 4Way	E	Tele + LCD + Plasma F + 4Way	F	Tele Multi + LCD + Plasma F + 4Way	G	Low A + Plasma F	H	Low A + Plasma F + 4Way	J	Plasma F + 4Way + Oxygen Generator	K	A/change + Plasma F	L	A/change + Plasma F + 4Way	M
Basic	A																										
Basic + 4Way	B																										
Plasma Filter	C																										
Plasma Filter + 4Way	D																										
Tele + LED + 4Way	E																										
Tele + LCD + Plasma F + 4Way	F																										
Tele Multi + LCD + Plasma F + 4Way	G																										
Low A + Plasma F	H																										
Low A + Plasma F + 4Way	J																										
Plasma F + 4Way + Oxygen Generator	K																										
A/change + Plasma F	L																										
A/change + Plasma F + 4Way	M																										
10	Serial No.	0~9																									

Safety Precautions



To prevent injury to the user or other people and property damage, the following instructions must be followed.

■ Incorrect operation due to ignoring instruction will cause harm or damage. The seriousness is classified by the following indications.

⚠ WARNING This symbol indicates the possibility of death or serious injury.

⚠ CAUTION This symbol indicates the possibility of injury or damage to properties only.

■ Meanings of symbols used in this manual are as shown below.

	Be sure not to do.
	Be sure to follow the instruction.

⚠ WARNING

■ Installation

Do not use damaged power cords, plugs, or a loose socket.

- There is risk of fire or electric shock.

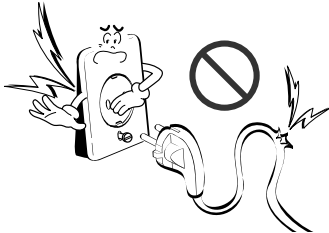

For electrical work, contact the dealer, seller, a qualified electrician, or an Authorized Service Center.

- There is risk of fire or electric shock.

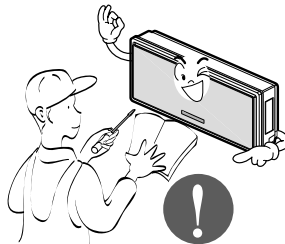

Always use the power plug and socket with the ground terminal.

- There is risk of electric shock.

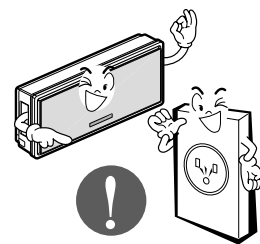

Install the panel and the cover of control box securely.

- There is risk of fire or electric shock.

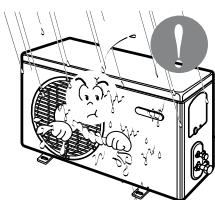

Do not modify or extend the power cord.

- There is risk of fire or electric shock.

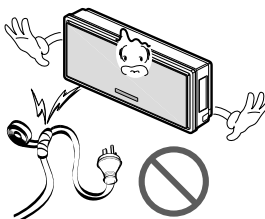

Do not install, remove, or re-install the unit by yourself (customer).

- There is risk of fire, electric shock, explosion or injury.



Be cautious when unpacking and installing the product.

- Sharp edges could cause injury. Be especially careful of the sharp edges.

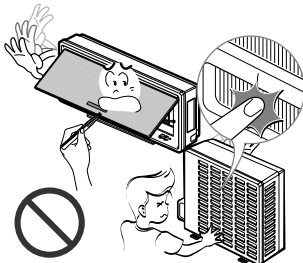

For installation, always contact the dealer or an Authorized Service Center.

- There is risk of fire, electric shock, explosion, or injury.

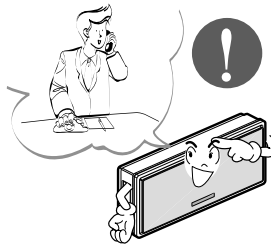

Do not install the product on a defective installation stand.

- It may cause injury, accident, or damage to the product.

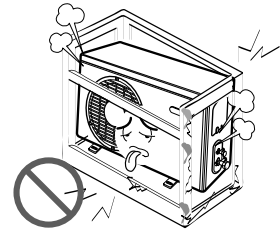

Be sure the installation area does not deteriorate with age.

- If the base collapses, the air conditioner could fall with it, causing property damage, product failure, and personal injury.

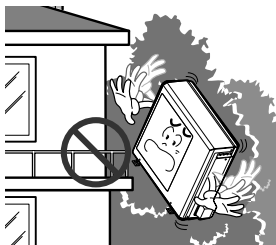

Install the indoor unit on the wall where the height from the floors more then 8ft(2.4m)

- There are sharp moving parts that could cause personal injury.

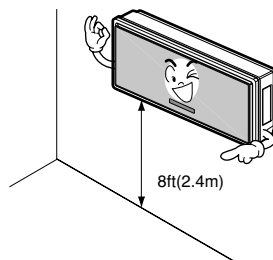

Do not handle the pipe by yourself(customer)

- High-Pressure refrigerant may cause personal injury.

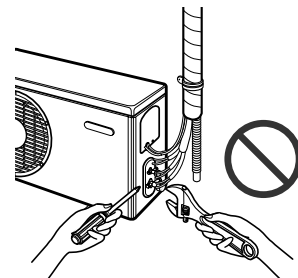

■ Operation

Use a dedicated outlet for this appliance.

- There is risk of fire or electric shock.

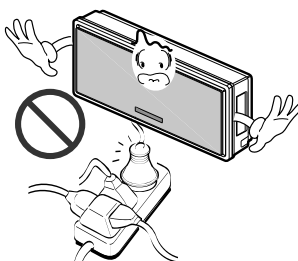

Grasp the plug to remove the cord from the outlet. Do not touch it with wet hands.

- There is risk of fire or electric shock.

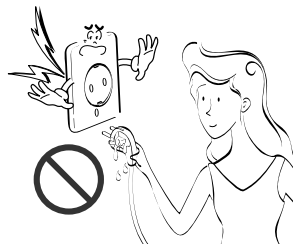

Do not allow water to run into electric part.

- There is risk of fire, failure of the product, and/or electric shock.

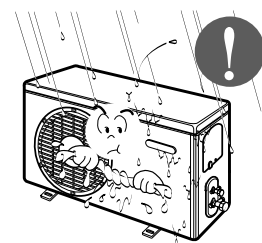

Do not place a heater or other appliances near the power cable.

- There is risk of fire, failure of the product, and/or electric shock.

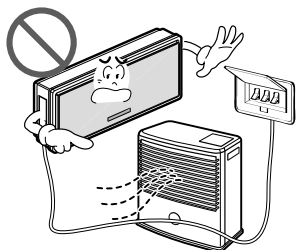

Do not let the air conditioner run for a long time when the humidity is very high and a door or a window is left open.

- Moisture may condense and wet or damage furnishings.

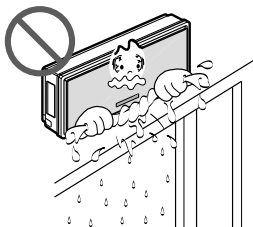

Do not store or use flammable gas or combustibles near the air conditioner.

- There is risk of fire or product failure.

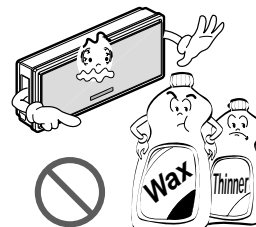

Do not use the product in a tightly closed space for a long time.

- Oxygen deficiency could occur.
- Some ventilation by opening window is necessary for the fresh air.

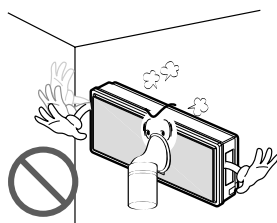

When flammable gas leaks, turn off the gas and open a window for ventilation before turning the product on. Do not use the telephone or turn switches on or off.

- There is risk of explosion or fire.

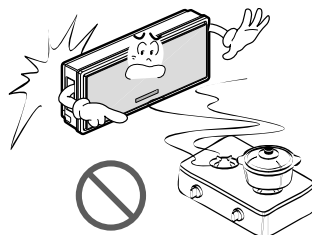

Unplug the unit if strange sounds odors or smoke comes from it.

- There is risk of fire product failure and/or electric shock.



Stop operation and close any window in storm or hurricane before the hurricane arrives.

- There is risk of property damage, failure of product, or electric shock.

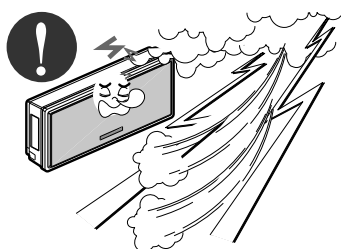

Do not open the inlet grill of the product during operation. (Do not touch the electrostatic filter, if the unit is so equipped.)

- There is risk of physical injury, electric shock, or product.



When the product is soaked (flooded or submerged), contact an Authorized Service Center.

- There is risk of electrical shock.



Ventilate the product from time to time when operating it together with a stove, etc.

- There is risk of fire or electrical shock.

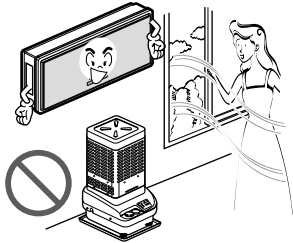

Unplug the appliance before performing cleaning or maintenance.

- There is risk of electric shock.

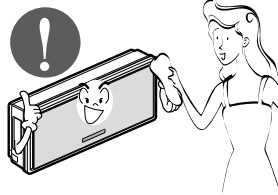

When the product is not be used for a long time disconnect the power supply plug or turn off the breaker.

- There is risk of product damage or failure, or unintended operation.

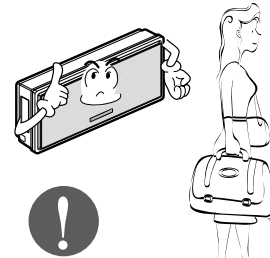

CAUTION

■ Installation

Take care to ensure that nobody could step on or fall onto the outdoor unit.

- There could result in personal injury and product damage.

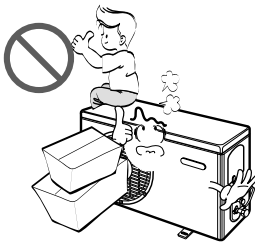

Do not insert hands or other objects through the air inlet or outlet while the air conditioner is plugged in.

- There are sharp and moving parts that could cause personal injury.

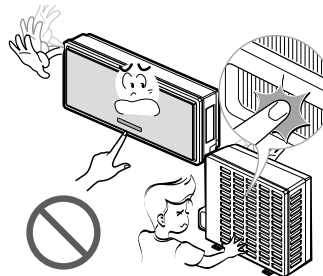

Always check for gas(refrigerant) leakage after installation or repair of product.

- Low refrigerant levels may cause product failure.

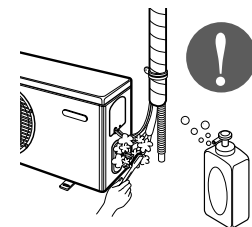

Install the drain hose to ensure that water is drained away properly.

- A bad connection may cause water leakage.

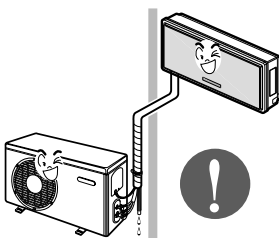

Keep level even when installing the product.

- To avoid vibration or water leakage.

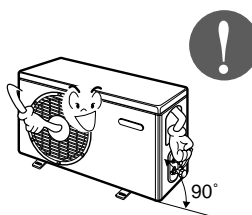

Do not install the product where the noise or hot air from the outdoor unit could damage the neighborhoods.

- It may cause a problem for your neighbors.

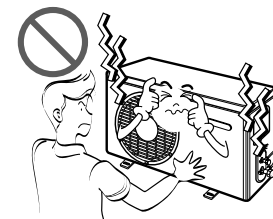

■ Operation

Use two or more people to lift and transport the air conditioner

- Avoid personal injury.

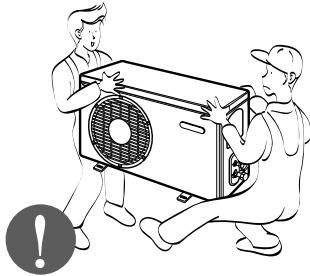

Do not install the product where it will be exposed to sea wind (salt spray) directly.

- It may cause corrosion in the product. Corrosion, particularly on the condenser and evaporator fins, could cause product malfunction or inefficient operation.

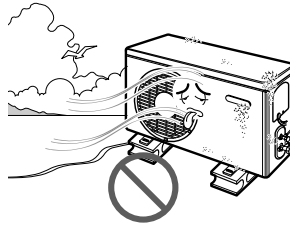

Do not direct airflow at room occupants.

- This could damage your health.

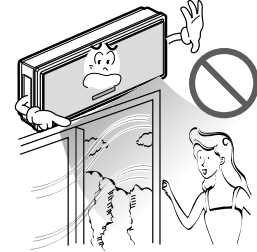

Do not use the product for special purposes, such as preserving foods, works of art, etc. It is a consumer air conditioner, not a precision refrigeration system.

- There is risk of damage or loss of property.

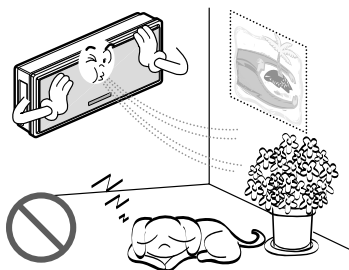

Do not block the inlet or outlet of air flow.

- It may cause product failure.

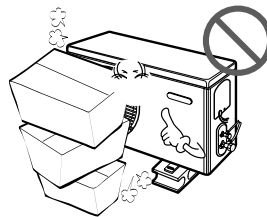

Use a soft cloth to clean. Do not use harsh detergents, solvents, etc.

- There is risk of fire, electric shock or damage to the plastic parts of the product.

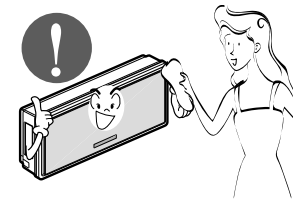

Do not touch the metal parts of the product when removing the air filter. They are very sharp!

- There is risk of personal injury.



Do not step on or put anything on the product. (outdoor unit)

- There is risk of personal injury and failure of product.

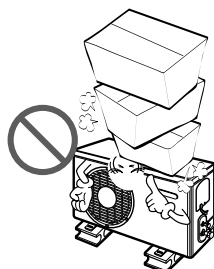

Always insert the filter securely. Clean the filter every two weeks or more often if necessary.

- A dirty filter reduces the efficiency of the air conditioner and



Do not drink the water drained from the unit.

- It is not sanitary and could cause serious health issues.

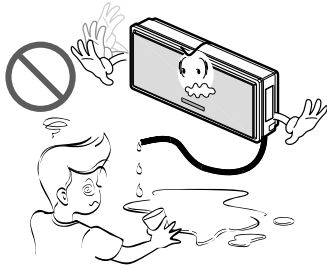

Use a firm stool or ladder when cleaning or maintaining the air conditioner.

- Be careful and avoid personal injury.

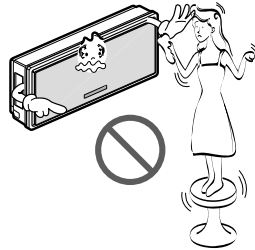

Replace all the batteries in the remote.

- There is risk of fire or explosion.

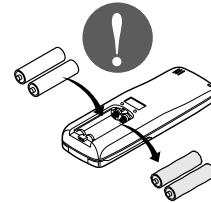

■ Disuse

Do not recharge or disassemble the batteries. Do not dispose of batteries in a fire.

- They may burn or explode.

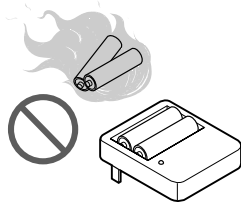

If the liquid from the batteries gets onto your skin or clothes, wash it well with clean water. Do not use the remote if the batteries have leaked.

- The chemicals in batteries could cause burns or other health hazards.



Functions

Indoor Unit

Operation ON/OFF by Remote controller

Sensing the Room Temperature

- Room temperature sensor. (THERMISTOR)

Room temperature control

- Maintains the room temperature in accordance with the Setting Temp.

Starting Current Control

- Indoor fan is delayed for 5 sec at the starting.

Time Delay Safety Control

- Restarting is inhibited for approx. 3 minutes.

Indoor Fan Speed Control

- High, Med, Low, CHAOS

Operation indication Lamps (LED)

Signal Receptor

Receives the signals from the remote control.(Signal receiving sound: two short beeps or one long beep.)

Operation Indication Lamps

- Ⓛ On/Off : Lights up during the system operation.
- ☆ Sleep Mode : Lights up during Sleep Mode Auto operation.
- ⌚ Timer : Lights up during Timer operation.
- ⚡ Defrost Mode : Lights up during Defrost Mode or Hot Start operation.(Heat pump model only)
- ⊕ Outdoor unit operation : Lights up during outdoor unit operation. (Cooling model only)

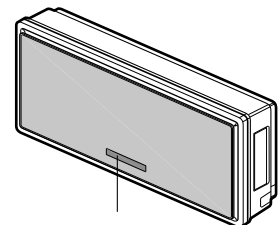

Operation indication lamps

Soft Dry Operation Mode

- Intermittent operation of fan at low speed.

Sleep Mode Auto Control

- The fan is switched to low(Cooling), med(Heating) speed.
- The unit will be stopped after 1, 2, 3, 4, 5, 6, 7 hours.

Natural Air Control by CHAOS Logic

- The fan is switched to intermittent or irregular operation
- The fan speed is automatically switched from high to low speed.

Airflow Direction Control

- The louver can be set at the desired position or swing up and down automatically.

Defrost(Deice) control (Heating)

- Both the indoor and outdoor fan stops during defrosting.

Hot-start Control (Heating)

- The indoor fan stops until the evaporator pipe temperature will be reached at 28°C.

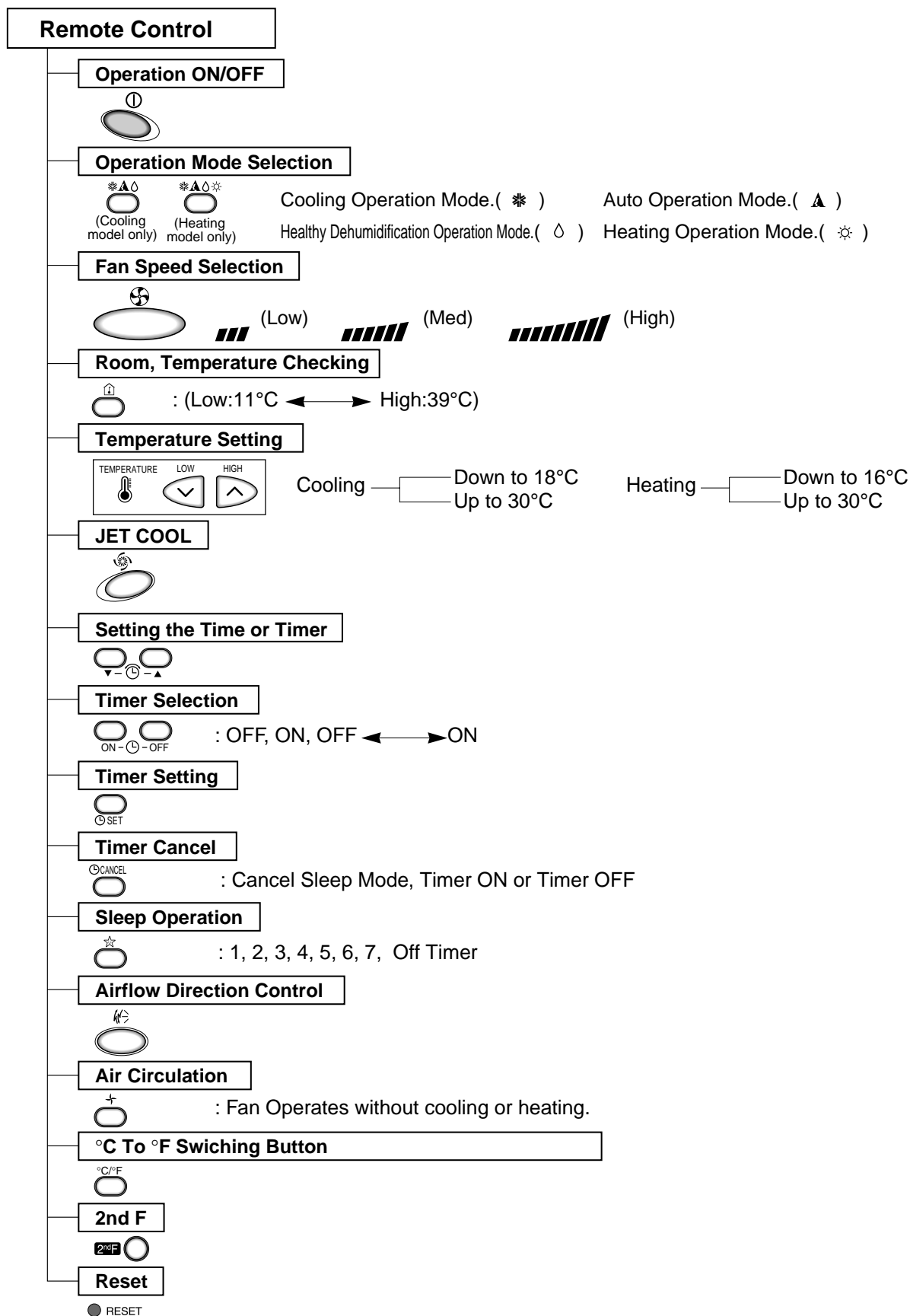

Product References

Items		Unit	LA*181CNW(AS-C183VML3)/LA180CP* (AS-C183VML3)
Power Supply		ø, V, Hz	1, 208/230, 60
Cooling Capacity		BTU/h	17 800/18 000
Input		W	2,000/2,000
Running Current		A	9.8/8.9
COMP. Locked Rotor AMP.		A	25*2
S.E.E.R			13
Air Circulation		m ³ /min(cfm)	13(460)
Moisture Removal		l/h(pts/hr)	2.5(5.3)
Noise Level (Sound Pressure, 1m)	Indoor, High	dB(A)±3	44
	Med	dB(A)±3	40
	Low	dB(A)±3	36
	Outdoor, Max	dB(A)±3	55
Features	Temperature Control		Thermistor
	Air Deflection		4-way
	Steps, Fan/Cool		3/4
	Airflow Direction Control(up&down)		Auto
	Airflow Direction Control(left&right)		Auto
	Remocon Type		Wireless LCD
	Setting Temperature Range, Cooling Mode		64~86°F(18~30°C)
	Temperature Increment		2°F(1°C)
	Auto Operation(electronic control)		Yes
	Self Diagnosis		Yes
	Timer		24hr, On/Off
	Sleep Operation		Yes
	Healthy Dehumidification Mode		Yes
	Restart Delay		minutes
Refrigerant(R-410A) Charge		g(oz)	900(31.8)
Power cord		AWG #: P*mm ²	14:3*2.5
Fuse or breaker Capacity		A	20
Connecting Cable		AWG #: P*mm ²	18:4*0.75
Connecting Tube (ø. Socket Flare)	Liquid Side	mm(in)	6.35(1/4)
	Gas Side	mm(in)	12.7(1/2)
	Length, std	m(ft)	7.5(25)
Additional Drain Hose(Outer Dia.)		mm(in)	19(3/4)
Dimensions (WxHxD)	Indoor	mm	928*522*147
		in	36 ¹ / ₂ *20 ¹⁹ / ₃₂ *5 ²⁵ / ₃₂
	Outdoor	mm	870*655*320
		in	34 ¹ / ₄ *25 ¹³ / ₁₆ *12 ⁵ / ₈
Net Weight	Indoor	kg(lbs)	17(37.5)
	Outdoor	kg(lbs)	68(149.9)
Gross Weight	Indoor	kg(lbs)	19(41.9)
	Outdoor	kg(lbs)	71(156.5)

NOTE: Please refer to Label Quality on the product since this specification may be changed for improving performance

Dimensions

Indoor Unit

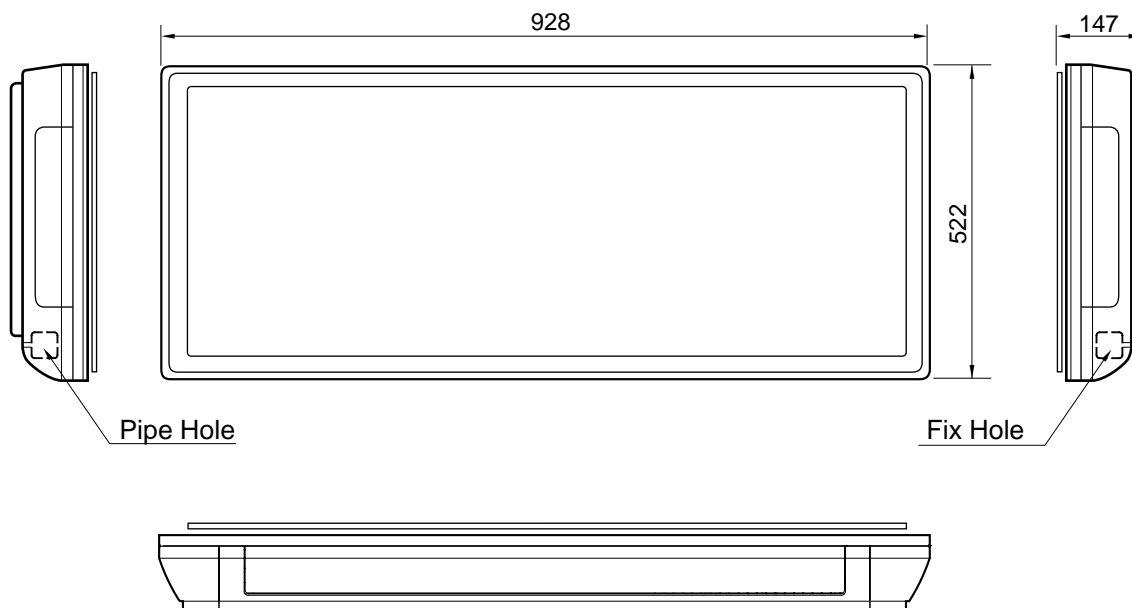

DIM	MODEL	
	Unit	Indoor Unit
W	mm(inch)	928(36.5)
H	mm(inch)	522(20.6)
D	mm(inch)	147(5.8)

Outdoor Unit

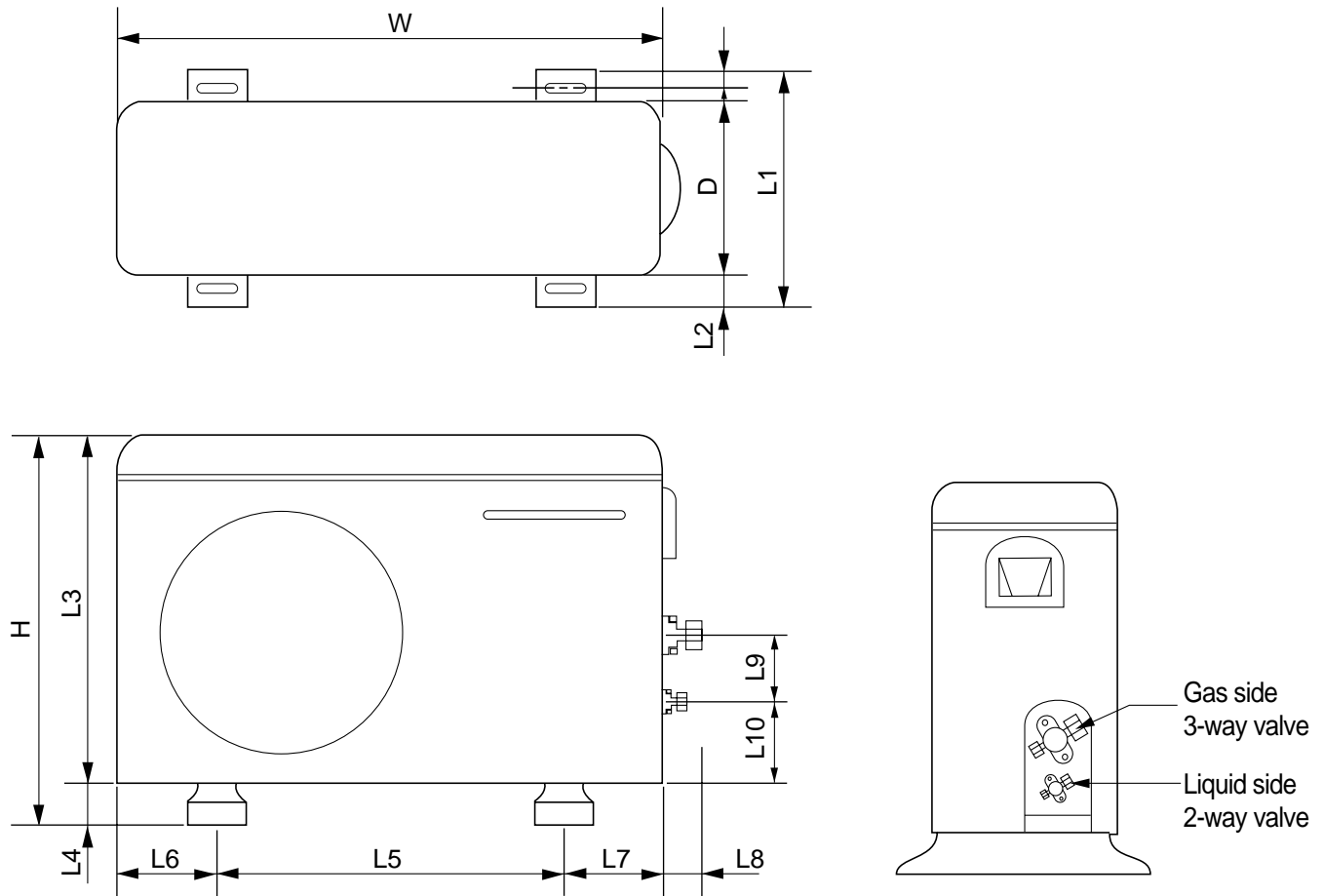

MODEL		OUTDOOR UNIT
DIM		
W	mm(inch)	870(34.3)
H	mm(inch)	655(25.8)
D	mm(inch)	320(12.6)
L1	mm(inch)	370(14.6)
L2	mm(inch)	25(1.0)
L3	mm(inch)	630(24.8)
L4	mm(inch)	25(1.0)
L5	mm(inch)	546(21.5)
L6	mm(inch)	162(6.4)
L7	mm(inch)	162(6.4)
L8	mm(inch)	54(2.1)
L9	mm(inch)	74.5(2.9)
L10	mm(inch)	79(3.1)

Refrigeration Cycle Diagram

Cooling Only Models

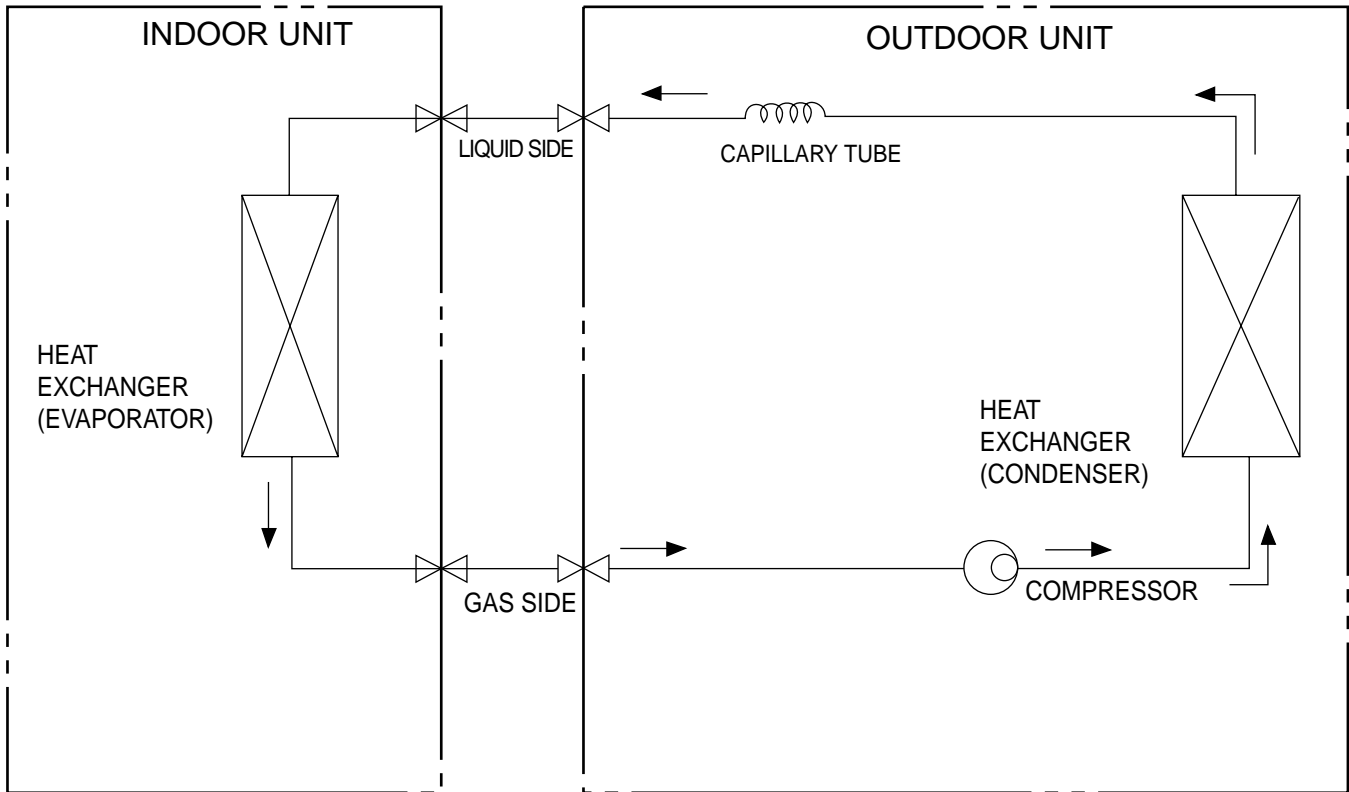

MODEL	Pipe size(Diameter:ø)		Piping length		Elevation	
	Gas	Liquid	Rated	Max	Rated	Max
18K (Cooling Only)	1/2"	1/4"	7.5m(24.6ft)	30m(98.4ft)	5m(16ft)	15m(49ft)

For installation over rated, *a proper quantity of refrigerant should be added for each meter.

a proper quantity of refrigerant	
18K	20g

Ex) 18K: When installed at a distance of 30m, 450g of refrigerant should be added.
 $(30-7.5) \times 20g = 450g$

Wiring Diagram

Indoor Unit

18K (Cooling Only Models)

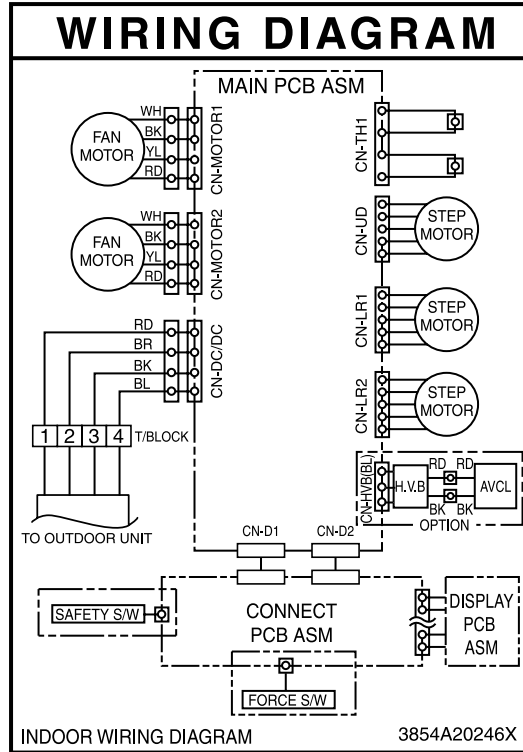

Outdoor Unit

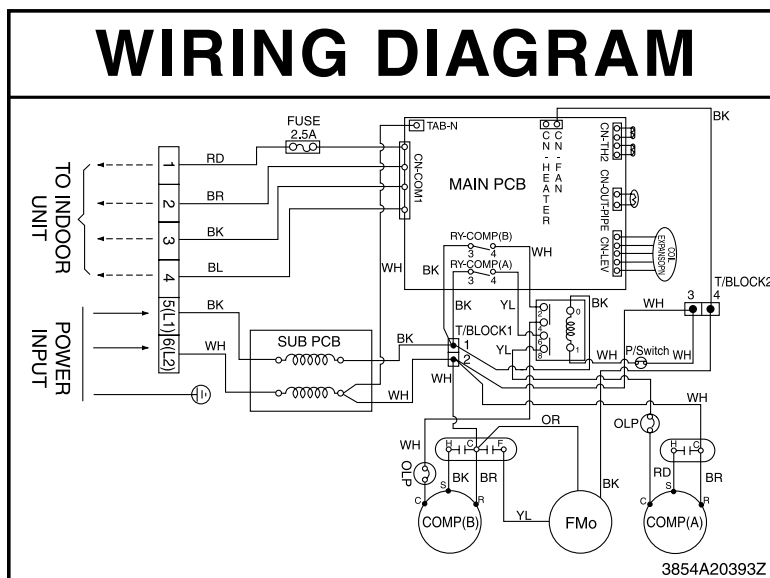

Operation Details

MAIN UNIT FUNCTION

• DISPLAY

1) C/O Model

Operation Indicator

- ON while in appliance operation, OFF while in appliance pause.
- Flashing while in disconnection or short in Thermistor. (3 sec off / 0.5 sec on)

Sleep Timer Indicator

- ON while in sleep timer mode, OFF when sleep timer cancel or appliance operation pause.

Timer Indicator

- ON while in timer mode (on/off), OFF when timer mode is completed or canceled.

Comp. Running Indicator

- While in appliance operation, ON while in outdoor unit compressor running, OFF while in compressor off.

2) H/P Model

Operation Indicator

- ON while in appliance operation, OFF while in appliance pause.
- Flashing while in disconnection or short in Thermistor. (3 sec off / 0.5 sec on)

Sleep Timer Indicator

- ON while in sleep timer mode, OFF when sleep timer cancel or appliance operation pause.

Timer Indicator

- ON while in timer mode (on/off), OFF when timer mode is completed or canceled.

Defrost Indicator

- OFF except when hot start during heating mode operation or while in defrost control.

■ Cooling Mode Operation

- When the intake air temperature reaches 0.5°C below the setting temp, the compressor and the outdoor fan stop.
- When it reaches 0.5°C above the setting temp, they start to operate again.

Compressor ON Temp	▶ Setting Temp+0.5°C
Compressor OFF Temp	▶ Setting Temp-0.5°C
- While in compressor running, operating with the airflow speed set by the remote control. While in compressor not running, operating with the low airflow speed regardless of the setting.

■ Healthy Dehumidification Mode

- When the dehumidification operation input by the remote control is received, the intake air temperature is detected and the setting temp is automatically set according to the intake air temperature.

26°C ≤ Intake Air Temp	▶ 25°C
24°C ≤ Intake Intake Air Temp < 26°C	▶ Intake Air Temp - 1°C
18°C ≤ Intake Intake Air Temp < 24°C	▶ Intake Air Temp - 0.5°C
Intake Air Temp < 18°C	▶ 18°C

- While in compressor off, the indoor fan repeats low airflow speed and pause.
- While the intake air temp is between compressor on temp. and compressor off temp., 10-min dehumidification operation and 4-min compressor off repeat.
Compressor ON Temp. ▶ Setting Temp+0.5°C
Compressor OFF Temp. ▶ Setting Temp-0.5°C
- In 10-min dehumidification operation, the indoor fan operates with the low airflow speed.

■ Heating Mode Operation

- When the intake air temp reaches +3°...above the setting temp, the compressor is turned off. When below the setting temp, the compressor is turned on.
Compressor ON Temp. ▶ Setting Temp.
Compressor OFF Temp. ▶ Setting Temp.+3°C
- While in compressor on, the indoor fan is off when the indoor pipe temp. is below 20°C, when above 28°C , it operates with the low or setting airflow speed. When the indoor pipe temp is between 20°C and 28°C, it operates with Super-Low(while in sleep mode, with the medium airflow speed).
- While in compressor off, the indoor fan is off when the indoor pipe temp is below 33°C, when above 35°C , it operates with the low airflow speed.
- If overloaded while in heating mode operation, in order to prevent the compressor from OLP operation, the outdoor fan is turned on/off according to the indoor pipe temp.
- While in defrost control, both of the indoor and outdoor fans are turned off.

■ Defrost Control

- While in heating mode operation in order to protect the evaporator pipe of the outdoor unit from freezing, reversed to cooling cycle to defrost the evaporator pipe of the outdoor unit.
- After 40 min heating mode operation, at 4 min interval, whether to carry out defrost control or not and the time of defrost control are determined according to the following conditions.
 - 1) While in heating mode operation, the maximum of the indoor pipe temperature is measured and it is compared with the present indoor pipe temperature to get the difference of the indoor pipe temperatures (=the maximum temperature of indoor pipe ? the present temperature of indoor pipe), according to which, whether to carry out defrost control or not is determined.
 - 2) According to the need of defrost control shown above and the elapsed time of heating mode operation at that moment, the defrost control time is determined.
 - 3) When the determined time of defrost control is below 7 min, heating mode operation continues without carrying out defrost control. According to the procedure stated above, the determination is made again. When the defrost control time is 7 min or longer, defrost control is then carried out.
- While in defrost control, the minimum temp of the indoor pipe is measured and it is compared with the present temp of the indoor pipe to get the difference of the indoor pipe temperatures (=the present temperature of the indoor pipe ? the minimum temperature of the indoor pipe). When the difference is 5°C or higher, defrost control is completed and heating mode operation is carried out.
- While in defrost control, if the defrost time determined before the start of defrost control is completed, defrost control stops and heating mode operation is carried out regardless of the above condition.
- When the indoor pipe temp is 42°C or above, defrost control is not carried out even if the condition is one of the defrost conditions above.
- While in defrost control, the compressor is on and the indoor fan, the outdoor fan, and the 4 way valve are off.

■ Fuzzy Operation (C/O Model)

- According to the temperature set by Fuzzy rule, when the intake air temp is 0.5°C or more below the setting temp, the compressor is turned off. When 0.5°C or more above the setting temp, the compressor is turned on.

Compressor ON Temp	▷ Setting Temp + 0.5°C
Compressor OFF Temp	▷ Setting Temp + 0.5°C
- At the beginning of Fuzzy mode operation, the setting temperature is automatically selected according to the intake air temp at that time.

26°C ≤ Intake Air Temp	▷ 25°C
24°C ≤ Intake Air Temp < 26°C	▷ Intake Air Temp + 1°C
22°C ≤ Intake Air Temp < 24°C	▷ Intake Air Temp + 0.5°C
18°C ≤ Intake Air Temp < 22°C	▷ Intake Air Temp
Intake Air Temp < 18°C	▷ 18°C
- When the Fuzzy key (Temperature Control key) is input after the initial setting temperature is selected, the Fuzzy key value and the intake air temperature at that time are compared to select the setting temperature automatically according to the Fuzzy rule.
- While in Fuzzy operation, the airflow speed of the indoor fan is automatically selected according to the temperature.

■ Fuzzy Operation (H/P Model)

- When any of operation mode is not selected like the moment of the power on or when 3 hrs has passed since the operation off, the operation mode is selected.
- When determining the operation mode, the compressor, the outdoor fan, and the 4 way valve are off and only the indoor fan is operated for 15 seconds. Then an operation mode is selected according to the intake air temp at that moment as follows.

24°C ≤ Intake Air Temp	▷ Fuzzy Operation for Cooling
21°C ≤ Intake Air Temp < 24°C	▷ Fuzzy Operation for Dehumidification
Intake Air Temp < 21°C	▷ Fuzzy Operation for Heating
- If any of the operation modes among cooling / dehumidification / heating mode operations is carried out for 10 sec or longer before Fuzzy operation, the mode before Fuzzy operation is operated.

1) Fuzzy Operation for Cooling

- According to the setting temperature selected by Fuzzy rule, when the intake air temp is 0.5°C or more below the setting temp, the compressor is turned off. When 0.5°C or more above the setting temp, the compressor is turned on.

Compressor ON Temp	▷ Setting Temp + 0.5°C
Compressor OFF Temp	▷ Setting Temp + 0.5°C
- At the beginning of Fuzzy mode operation, the setting temperature is automatically selected according to the intake air temp at that time.

26°C ≤ Intake Air Temp	▷ 25°C
24°C ≤ Intake Air Temp < 26°C	▷ Intake Air Temp + 1°C
22°C ≤ Intake Air Temp < 24°C	▷ Intake Air Temp + 0.5°C
18°C ≤ Intake Air Temp < 22°C	▷ Intake Air Temp
Intake Air Temp < 18°C	▷ 18°C
- When the Fuzzy key (Temperature Control key) is input after the initial setting temperature is selected, the Fuzzy key value and the intake air temperature at that time are compared to select the setting temperature automatically according to the Fuzzy rule.
- While in Fuzzy operation, the airflow speed of the indoor fan is automatically selected according to the temperature.

2) Fuzzy Operation for Dehumidification

- According to the setting temperature selected by Fuzzy rule, when the intake air temp is 0.5°C or more below the setting temp, the compressor is turned off. When 0.5°C or more above the setting temp, the compressor is turned on.
 - Compressor ON Temp ▶ Setting Temp + 0.5°C
 - Compressor OFF Temp ▶ Setting Temp+0.5°C
- At the beginning of Fuzzy mode operation, the setting temperature is automatically selected according to the intake air temp at that time.
 - 26°C ≤ Intake Air Temp ▶ 25°C
 - 24°C ≤ Intake Air Temp < 26°C ▶ Intake Air Temp+1°C
 - 22°C ≤ Intake Air Temp < 24°C ▶ Intake Air Temp+0.5°C
 - 18°C ≤ Intake Air Temp < 22°C ▶ Intake Air Temp
 - Intake Air Temp < 18°C ▶ 18°C
- When the Fuzzy key (Temperature Control key) is input after the initial setting temperature is selected, the Fuzzy key value and the intake air temperature at that time are compared to select the setting temperature automatically according to the Fuzzy rule.
- While in Fuzzy operation, the airflow speed of the indoor fan repeats the low airflow speed or pause as in dehumidification operation.

3) Fuzzy Operation for Heating

- According to the setting temperature selected by Fuzzy rule, when the intake air temp is 3°C or more above the setting temp, the compressor is turned off. When below the setting temp, the compressor is turned on.
 - Compressor ON Temp ▶ Setting Temp
 - Compressor OFF Temp ▶ Setting Temp + 3°C
- At the beginning of Fuzzy mode operation, the setting temperature is automatically selected according to the intake air temp at that time.
 - 20°C ≤ Intake Air Temp ▶ Intake Air Temp + 0.5°C
 - Intake Air Temp < 20°C ▶ 20°C
- When the Fuzzy key (Temperature Control key) is input after the initial setting temperature is selected, the Fuzzy key value and the intake air temperature at that time are compared to select the setting temperature automatically according to the Fuzzy rule.
- While in Fuzzy operation, the airflow speed of the indoor fan is set to the high or the medium according to the intake air temperature and the setting temperature.

■ Airflow Speed Selection

- The airflow speed of the indoor fan is set to high, medium, low, or chaos (auto) by the input of the airflow speed selection key on the remote control.

■ On-Timer Operation

- When the set time is reached after the time is input by the remote control, the appliance starts to operate.
- The timer LED is on when the on-timer is input. It is off when the time set by the timer is reached.
- If the appliance is operating at the time set by the timer, the operation continues.

■ Off-Timer Operation

- When the set time is reached after the time is input by the remote control, the appliance stops operating.
- The timer LED is on when the off-timer is input. It is off when the time set by the timer is reached.
- If the appliance is on pause at the time set by the timer, the pause continues.

■ Off-Timer ↔ On-Timer Operation

- When the set time is reached after the on/off time is input by the remote control, the on/off-timer operation is carried out according to the set time.

■ Sleep Timer Operation

- When the sleep time is reached after <1,2,3,4,5,6,7,0(cancel) hr> is input by the remote control while in appliance operation, the operation of the appliance stops.
- While the appliance is on pause, the sleep timer mode cannot be input.
- While in cooling mode operation, 30 min later since the start of the sleep timer, the setting temperature increases by 1°C. After another 30 min elapse, it increases by 1°C again.
- When the sleep timer mode is input while in cooling cycle mode, the airflow speed of the indoor fan is set to the low.
- When the sleep timer mode is input while in heating cycle mode, the airflow speed of the indoor fan is set to the medium.

■ Chaos Swing Mode

- By the Chaos Swing key input, the louvers vane automatically operate with the Chaos Swing or they are fixed to the desired direction.
- While in Chaos Swing mode, the angles of cooling and heating cycle operations are different.

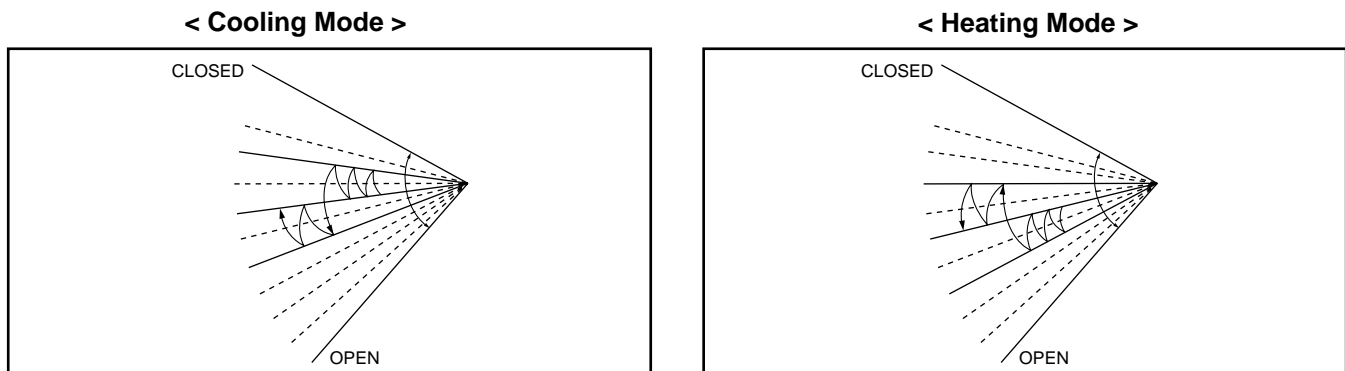

■ Jet Cool Mode Operation (C/O Model)

- If the Jet Cool key is input at any operation mode while in appliance operation, the Jet Cool mode operates.
- In the Jet Cool mode, the indoor fan is operated at super-high speed for 30 min at cooling mode operation.
- In the Jet Cool mode operation, the room temperature is controlled to the setting temperature, 18°C
- When the sleep timer mode is input while in the Jet Cool mode operation, the Jet Cool mode has the priority.
- During the JET COOL function at any moment, the A/C starts to blow the cool air with side louvers closed at extremely high speed for 30 minutes setting the room temp. automatically to 18°C.

■ Jet Cool Mode Operation (H/P Model)

- While in heating mode or Fuzzy operation, the Jet Cool key cannot be input. When it is input while in the other mode operation (cooling, dehumidification, ventilation), the Jet Cool mode is operated.
- In the Jet Cool mode, the indoor fan is operated at super-high speed for 60 min at cooling mode operation.
- In the Jet Cool mode operation, the room temperature is controlled to the setting temperature, 18°C.
- When the sleep timer mode is input while in the Jet Cool mode operation, the Jet Cool mode has the priority.
- During the JET HEAT function at any moment, the A/C starts to blow the hot air with side louvers closed at extremely high speed for 60 minutes setting the room temp. automatically to 30°C.

■ Forced Operation

- Operation procedures when the remote control can't be used.
- The operation will be started if the power button is pressed.
- If you want to stop operation, re-press the button.

	Cooling Model	Heat pump Model		
		Room Temp. $\geq 24^{\circ}\text{C}$	$21^{\circ}\text{C} \leq \text{Room Temp.} < 24^{\circ}\text{C}$	Room Temp. $< 21^{\circ}\text{C}$
Operating mode	Cooling	Cooling	Healthy Dehumidification	Heating
Indoor FAN Speed	High	High	High	High
Setting Temperature	22°C	22°C	23°C	24°C

- While in forced operation, the key input by the remote control has no effect and the buzzer sounds 10 times to indicate the forced operation.

■ Test operation

- During the TEST OPERATION, the unit operates in cooling mode at high speed fan, regardless of room temperature and resets in 18 ± 1 minutes.
- During test operation, if remote controller signal is received, the unit operates as remote controller sets. If you want to use this operation, open the front panel upward and Press the power button let it be pressed for about 3 seconds.
- If you want to stop the operation, re-press the button.

■ Auto restart

- In case the power comes on again after a power failure, Auto Restarting Operation is the function to operate procedures automatically to the previous operating conditions.

■ Remote Control Operation Mode

- When the remote control is selected by the slide switch on the main unit, the appliance operates according to the input by the remote control.

■ Protection of the evaporator pipe from frosting

- If the indoor pipe temp is below 0°C in 7 min. after the compressor operates without any pause while in cooling cycle operation mode, the compressor and the outdoor fan are turned off in order to protect the indoor evaporator pipe from frosting.
- When the indoor pipe temp is 7°C or higher after 3 min. pause of the compressor, the compressor and the outdoor fan is turned on according to the condition of the room temperature.

■ Buzzer Sounding Operation

- When the appliance-operation key is input by the remote control, the short "beep-beep-" sounds.
- When the appliance-pause key is input by the remote control, the long "beep—" sounds.
- When a key is input by the remote control while the slide switch on the main unit of the appliance is on the forced operation position, the error sound "beep-beep-beep-beep-beep-" is made 10 times to indicate that the remote control signal cannot be received.

Display Function

1. Heating Model

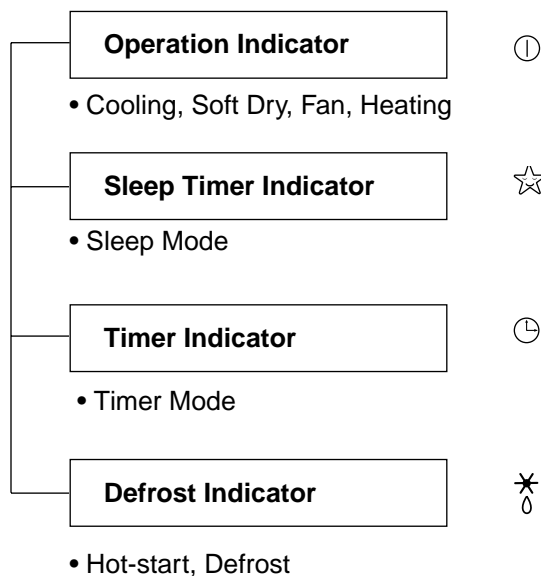

2. Cooling Model

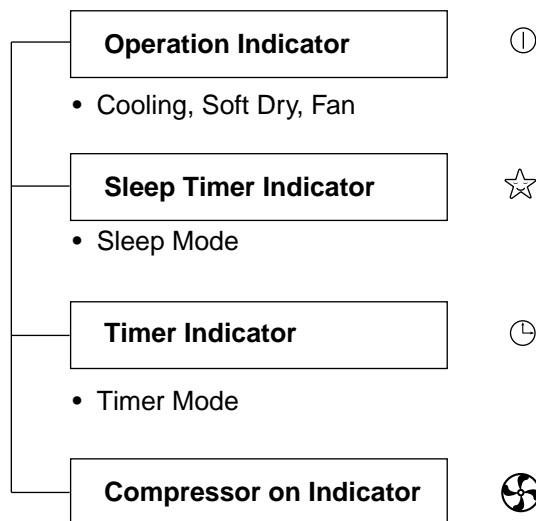

Self-diagnosis Function

Error Code	Error Display LED (Indoor body operation LED)	Error contents	SVC check point
1	<p>(once)</p> <p>3sec 3sec 3sec</p>	<ul style="list-style-type: none"> Indoor room temperature thermistor open/short Indoor pipe temperature thermistor open/short. 	<ul style="list-style-type: none"> Indoor Thermistor assembly check

Introduction

Symbols used in this Manual



This symbol alerts you to the risk of electric shock.



This symbol alerts you to hazards that may cause harm to the air conditioner.

NOTICE

This symbol indicates special notes.

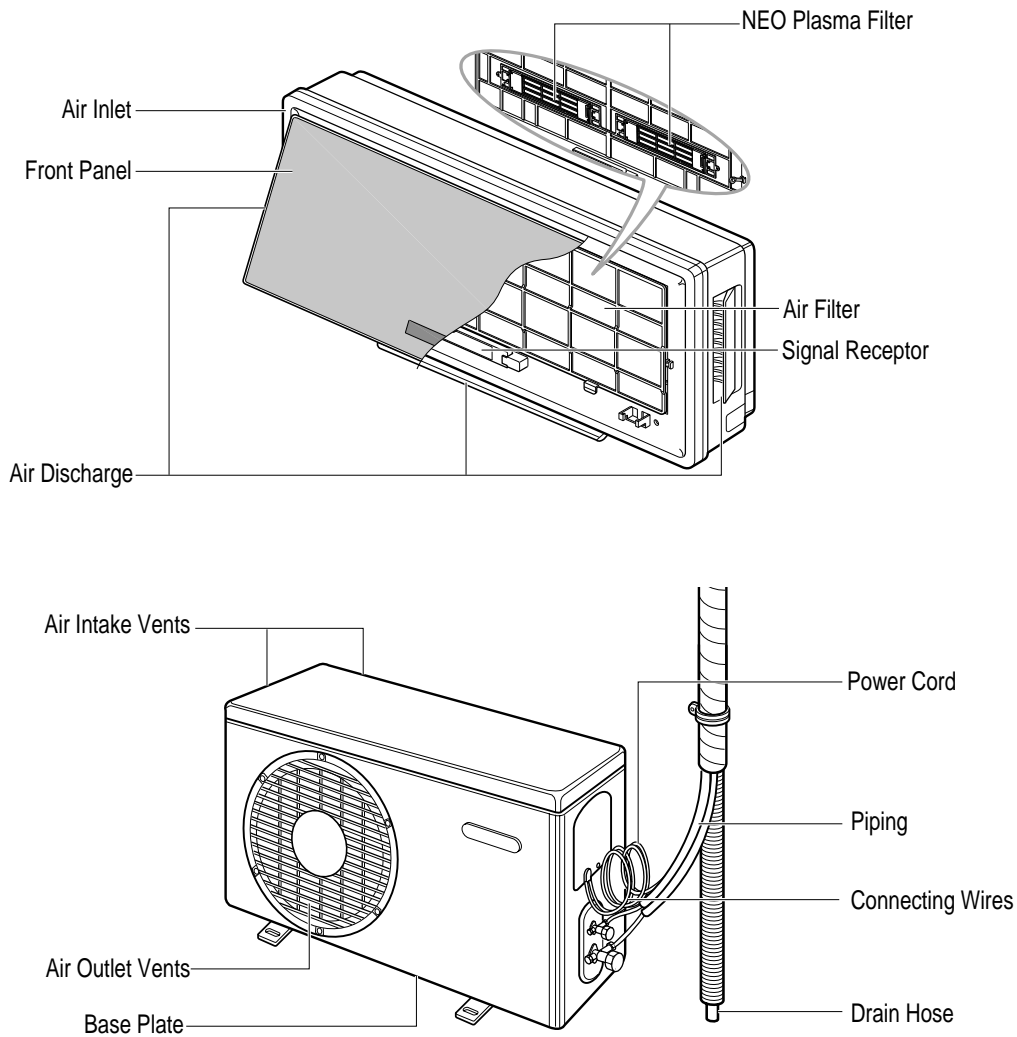

Features







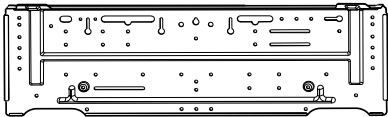

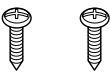
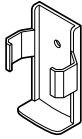

Installation

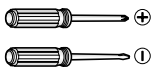
Read carefully, and then follow step by step.

Installation Parts

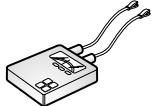
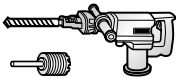
<p>Installation plate</p>	<p>Type "A" screw and plastic anchor</p>
	
<p>Type "B" screw</p>	<p>Remote control holder</p>
	

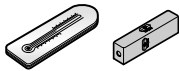
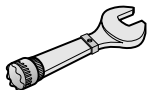
Installation Tools

Figure	Name	Figure	Name
	<p>Screw driver</p>		<p>Ohmmeter</p>
	<p>Electric drill</p>		<p>Hexagonal wrench</p>
	<p>Measuring tape, Knife</p>		<p>Ammeter</p>
	<p>Hole core drill</p>		<p>Gas-leak detector</p>
	<p>Spanner</p>		<p>Thermometer, Horizontal meter</p>
	<p>Torque wrench</p>		<p>Flaring tool set</p>

Installation Map

NOTICE Installation parts you should purchase. (※)

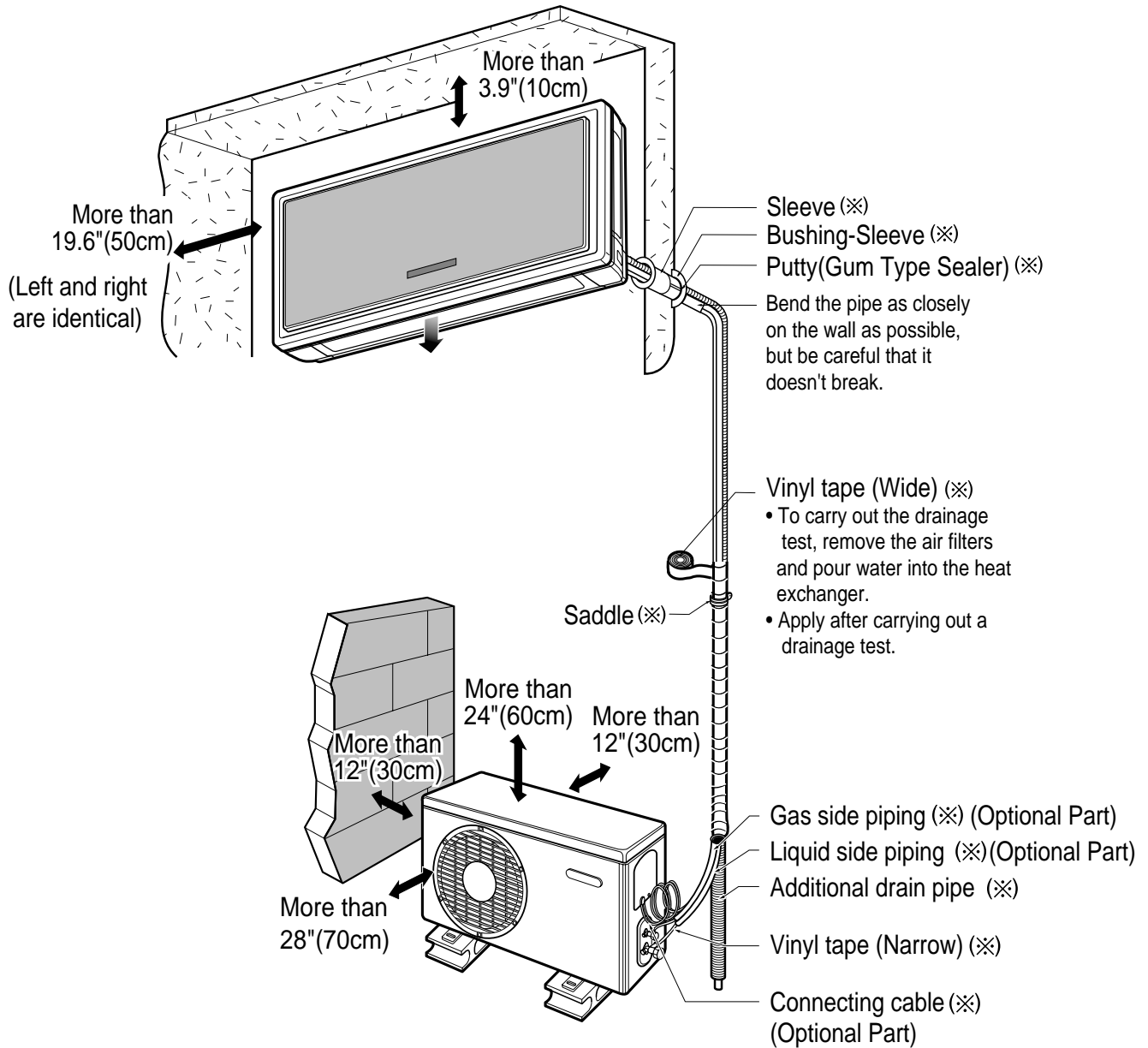

Confirm The Refrigerant

1. Check the quality label on the indoor and outdoor unit.
2. Make certain that the refrigerant is R-410A.

NOTICE

THIS PRODUCT CONTAINS R-410A REFRIGERANT

- 1) Different compressor oil
 - R-410A(Polyol ester) / R-22(Mineral).
 - Do not mix the existing mineral oil.
 - Do not apply used pipe, tools and gauges covered with the existing mineral oil.
- 2) Absorption of moisture
 - Compressor's oil has the high absorption rate of moisture.
- 3) Composition
 - R-410A(R32:R125=50:50wt%).

NOTE: Never mix with other refrigerants

Example : Split type 12,000 Btu/h

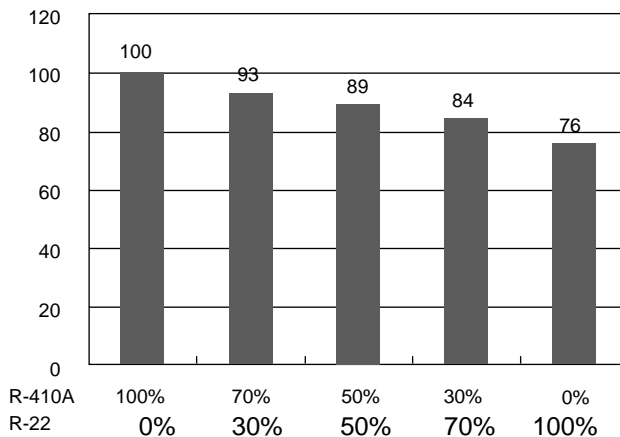

- 4) High pressure.
 - 1.6 times higher than R-22.
 - High Pressure refrigerant may cause personal injury.

	Boiling Pt.(°C)	Vapor pressure(25°C)(kg f/cnf)	Vapor density(25°C)(kg/m ²)
R-410A	-51.4	15.9	64
R-22	-40.8	9.6	44.4

Do not handle the pipe by yourself (customer) High-pressure refrigerant may cause personal injury.
 - manifold gauge ,charging and any piping tools must be dedicated to R-410A systems.

Installation of indoor, Outdoor unit

Read completely, then follow step by step.

1) Select the best location

1. Indoor unit

- Do not have any heat or steam near the unit.
- Select a place where there are no obstacles in front of the unit.
- Make sure that condensation drainage can be conveniently routed away.
- Do not install near a doorway.
- Ensure that the space around the left and right of the unit is more than 50cm(19.7"). The unit should be installed as high on the wall as possible, allowing a minimum of 10cm(3.9") from ceiling.
- Use a stud finder to locate studs to prevent unnecessary damage to the wall.

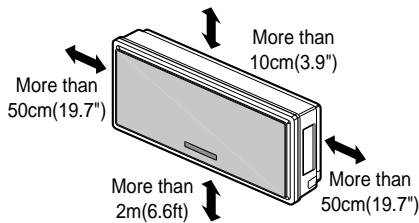

CAUTION

Install the indoor unit on the wall where the height from the floors more than 2m(6.6ft).

2. Outdoor unit

- If an awning is built over the unit to prevent direct sunlight or rain exposure, make sure that heat radiation from the condenser is not restricted.
- Ensure that the space around the back and sides is more than 30cm(12"). The front of the unit should have more than 70cm(27.5") of space.
- Do not place animals and plants in the path of the warm air.
- Take the air conditioner weight into account and select a place where noise and vibration are minimum.
- Select a place so that the warm air and noise from the air conditioner do not disturb neighbors.

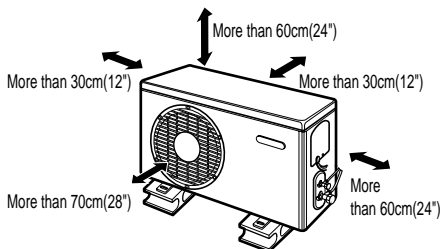

■ Rooftop Installations:

If the outdoor unit is installed on a roof structure, be sure to level the unit. Ensure the roof structure and anchoring method are adequate for the unit location. Consult local codes regarding rooftop mounting.

2) Piping length and elevation

Capacity (Btu/h)	Pipe Size		Standard Length (m)	Max. Elevation B (m)	Max. length A (m)	Additional Refrigerant (g/m)
	GAS	LIQUID				
18k	1/2"	1/4"	7.5 (24.6ft)	15 (49.2ft)	30 (98.4ft)	20

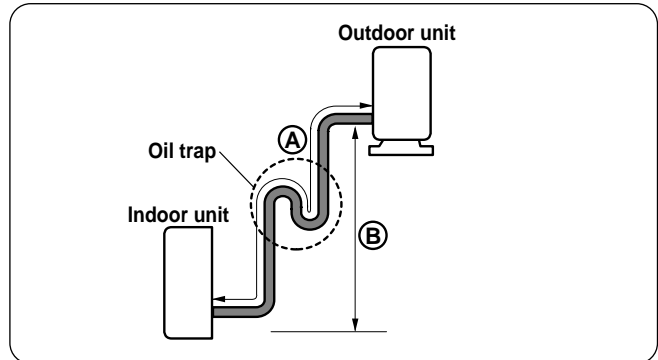
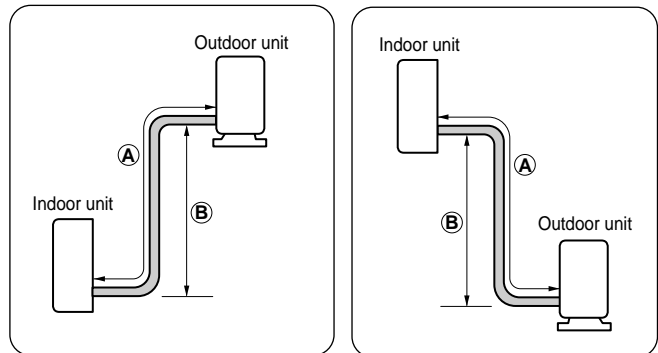

In case more than 5m(16.4ft)

CAUTION

- Capacity is based on standard length and maximum allowance length is on the basis of reliability.
- Oil trap should be installed every 5~7 meters(16.4~23ft).

3) Preparing work for Installation

1. Open panel front

- First, Pull the grille bottom, then remove screws(2 pieces), and close grille bottom again.
- The moment of lifting the both lower parts of panel front, you can hear sound this panel came out, In this time panel front is separated
- After pull down this panel a bit, and separate connecting wire with product.

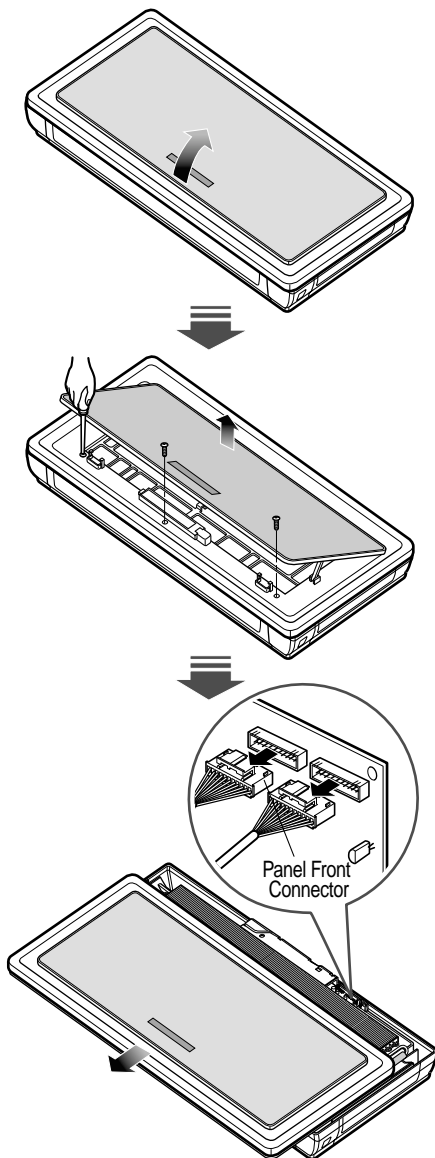

2. Cover pipe and cover side remove

- Remove two screws(for fixing cover pipe)
- Pull up the cover side of desired connecting direction, then cover side is separated.
- In case connecting direction is left or right, path through the hole of cover side.

CAUTION

After removing the pipe hole, cut the burr for safety.

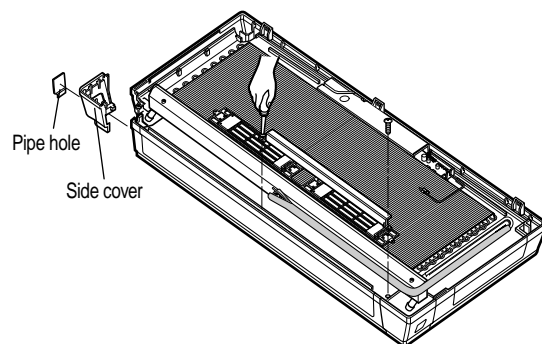

When connecting pipe path through rear wall, don't remove the hole.

3. Drain hose junction

- Remove the rubber stopple of desired drain direction.
- As the following picture, Insert drain hose in the handle of drain pan, and join drain hose and connecting hose.

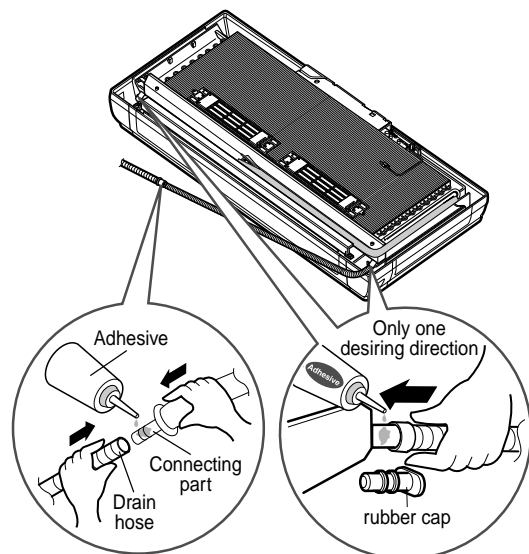

4) How to fix installation plate

The wall you select should be strong and solid enough to prevent vibration

A Mount the installation plate on the wall with type "A" screws. If mounting the unit on a concrete wall, use anchor bolts.

■ Mount the installation plate horizontally by aligning the centerline using a level.

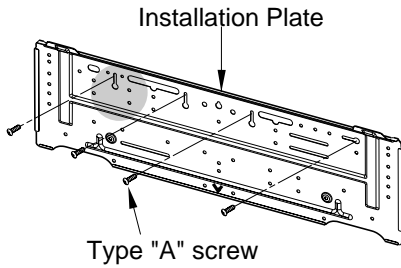

B Measure the wall and mark the centerline. It is also important to use caution concerning the location of the installation plate—routing of the wiring to power outlets is through the walls typically. Drilling the hole through the wall for piping connections must be done safely.

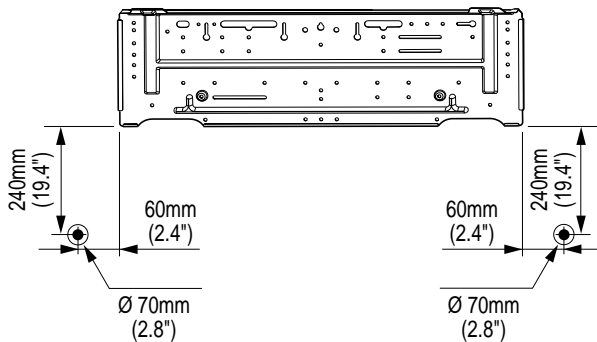

5) Preparing work for installation

1. Drill a hole in the wall
 - Drill the piping hole with a $\varnothing 50\text{mm}$ hole core drill. Drill the piping hole at either the right or the left with the hole slightly slanted to the outdoor side.

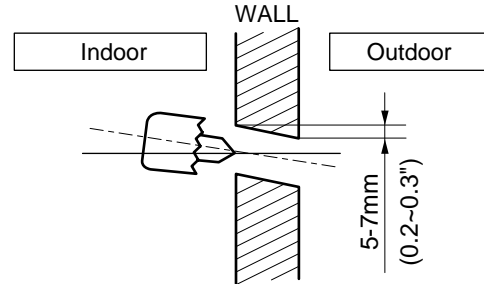

Flaring Work and Connection of Piping

1) Flaring work

Main cause for refrigerant leakage is due to defect in the flaring work. Carry out correct flaring work using the following procedure.

1. Cut the pipes and the cable.

- Use the piping kit accessory or pipes purchased locally.
- Measure the distance between the indoor and the outdoor unit.
- Cut the pipes a little longer than the measured distance.
- Cut the cable 1.5m longer than the pipe length.

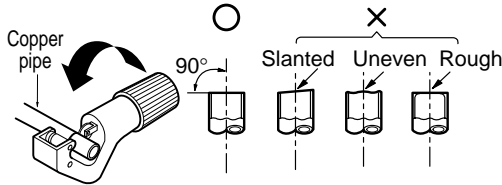

2. Burr removal

- Completely remove all burrs from the cut cross section of pipe/tube.
- Put the end of the copper tube/pipe in a downward direction as you remove burrs in order to avoid dropping burrs into the tubing.

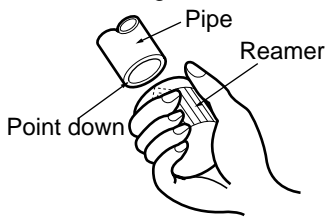

3. Putting nut on

- Remove flare nuts attached to indoor and outdoor unit, then put them on pipe/tube having completed burr removal. (not possible to put them on after flaring work)

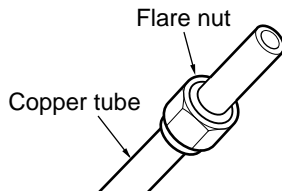

4. Flaring work

- Firmly hold copper pipe in a die in the dimension shown in the table above.

Outside diameter		A
mm	inch	mm
Ø6.35	1/4	1.1~1.3
Ø9.52	3/8	1.5~1.7
Ø12.7	1/2	1.6~1.8
Ø15.88	5/8	1.6~1.8

- Carry out flaring work using flaring tool as shown below.

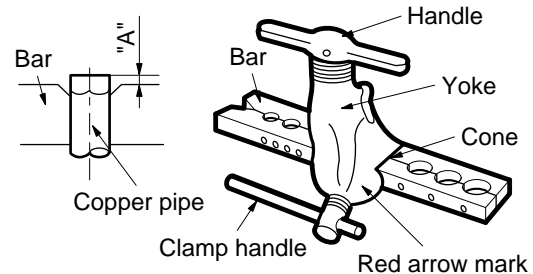

5. Check

- Compare the flared work with figure below.
- If flare is noted to be defective, cut off the flared section and re-flare it.

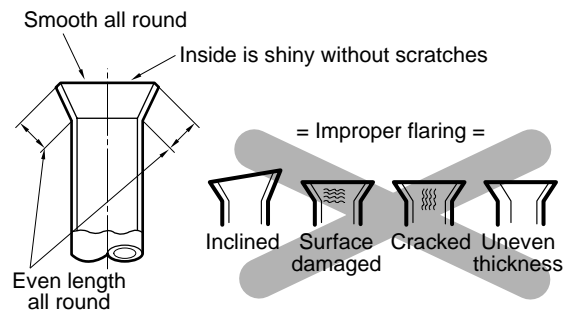

2) Connection of piping Indoor

- Preparing the indoor unit's piping and drain hose for installation through the wall.

1. Route the indoor tubing and the drain hose in the direction of rear left or right.

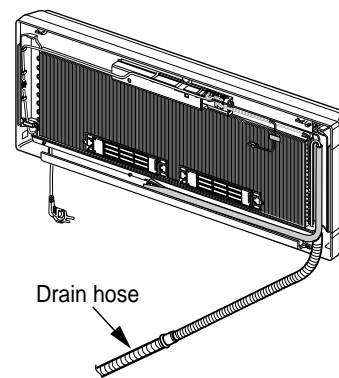

- 2. Tape the tubing, drain hose, and the connecting cable. Be sure that the drain hose is located at the lowest side of the bundle. Locating at the upper side can cause drain pan to overflow inside the unit.**

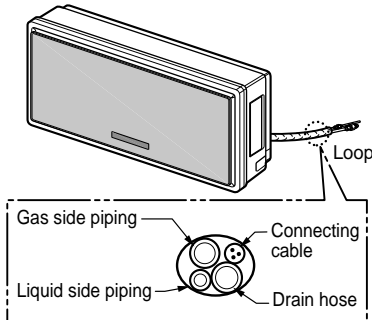

NOTE: If the drain hose is routed inside the room, insulate the hose with an insulation material* so that dripping from "sweating"(condensation) will not damage furniture or floors.

*Foamed polyethylene or equivalent is recommended.

3. Indoor unit installation

- Hook the indoor unit onto the upper portion of the installation plate.(Engage the two hooks of the rear top of the indoor unit with the upper edge of the installation plate.) Ensure that the hooks are properly seated on the installation plate by moving it left and right.

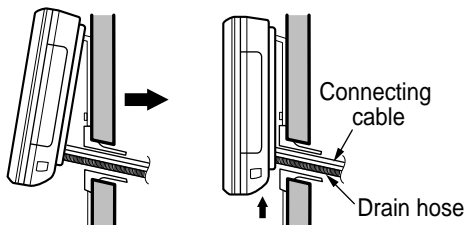

4. Connecting the pipings to the indoor unit and drain hose to drain pipe.

- Align the center of the pipes and sufficiently tighten the flare nut by hand.

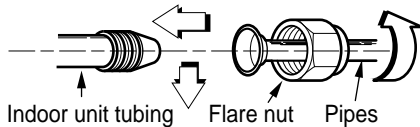

- Tighten the flare nut with a wrench.

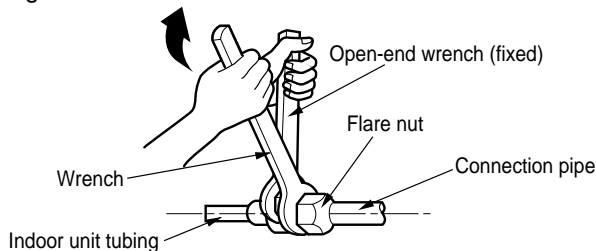

Outside diameter		Torque
mm	inch	Kgf·cm
Ø6.35	1/4	180~250
Ø9.52	3/8	340~420
Ø12.7	1/2	350~660
Ø15.88	5/8	630~820
Ø19.05	3/4	990~1210

- When extending the drain hose at the indoor unit, install the drain pipe.

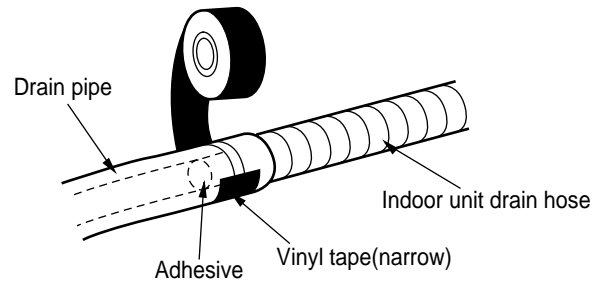

5. Wrap the insulation material around the connecting portion.

- Overlap the connection pipe insulation material and the indoor unit pipe insulation material. Bind them together with vinyl tape so that there is no gap.

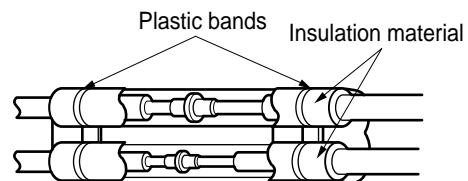

- Wrap the area which accommodates the rear piping housing section with vinyl tape.

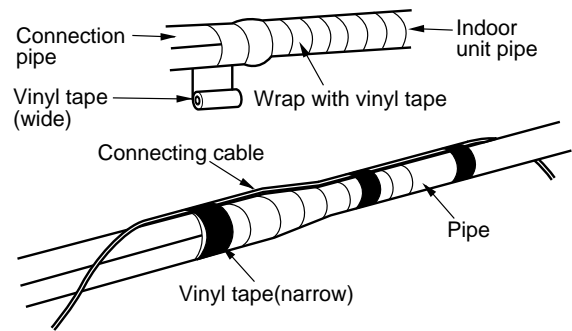

- Bundle the piping and drain hose together by wrapping them with vinyl tape for enough to cover where they fit into the rear piping housing section.

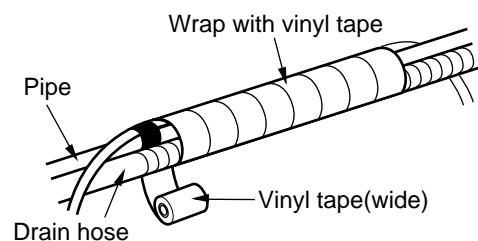

CAUTION

Installation Information (For right piping)

- **Good case**
For right piping. Follow the instruction below.
- Press on the upper side of clamp and unfold the tubing to downward slowly.

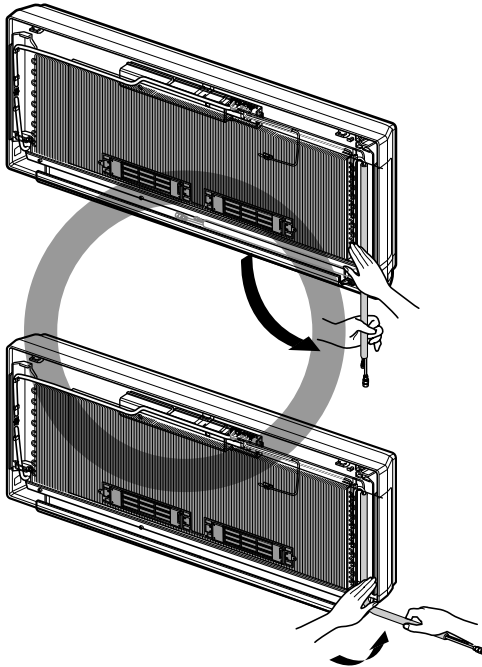

- **Bad case**
- Following bending type from left to right could cause problem of pipe damage.

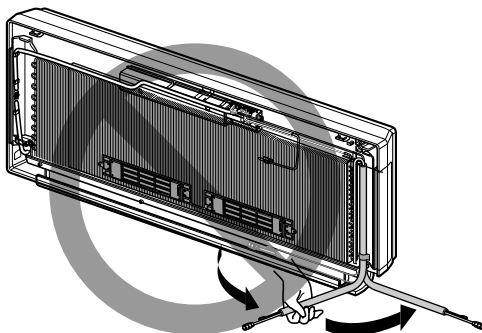

3) Connection of the pipes-Outdoor

1. Align the center of the pipings and sufficiently tighten the flare nut by hand.

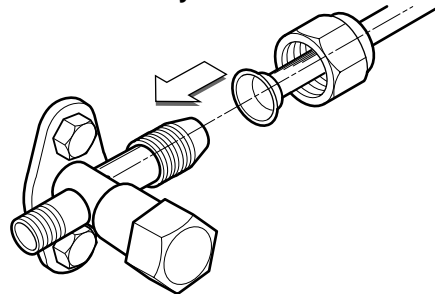

2. Finally, tighten the flare nut with torque wrench until the wrench clicks.

- When tightening the flare nut with torque wrench, ensure the direction for tightening follows the arrow on the wrench.

Outside diameter		Torque Kg·cm
mm	inch	
Ø6.35	1/4	180~250
Ø9.52	3/8	340~420
Ø12.7	1/2	550~660
Ø15.88	5/8	630~820
Ø19.05	3/4	990~1210

Outdoor unit

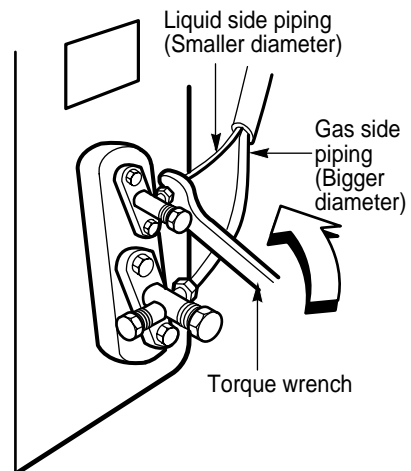

Connecting The Cable Between Indoor Unit and Outdoor Unit

1) Connection of the cable

1. Remove the cover control from the unit by loosening the 3 screws.
2. Dismount caps on the conduit panel.
3. Temporarily mount the conduit tubes on the conduit panel.
4. Properly connect both the power supply and low voltage lines to the corresponding terminals on the terminal block.
5. Ground the unit in accordance with local codes.
6. Be sure to size each wire allowing several inches longer than the required length for wiring.
7. Use lock nuts to secure the conduit tubes.

NOTE

Connector trade size for this unit is 1/2". Refer to "How to connect wiring to the terminals" for instructions on connecting depending on the wire type you are using.

WARNING

- Be sure to comply with local codes while running the wire from the indoor unit to the outdoor unit (size of wire and wiring method, etc).
- Every wire must be connected firmly.
- No wire should be allowed to touch refrigerant tubing, the compressor or any moving parts.

Power Supply

Model	Power source	AWG(MIN.)		Fuse or breaker Capacity
18K	1 ϕ , 208/230V	14	18	20A

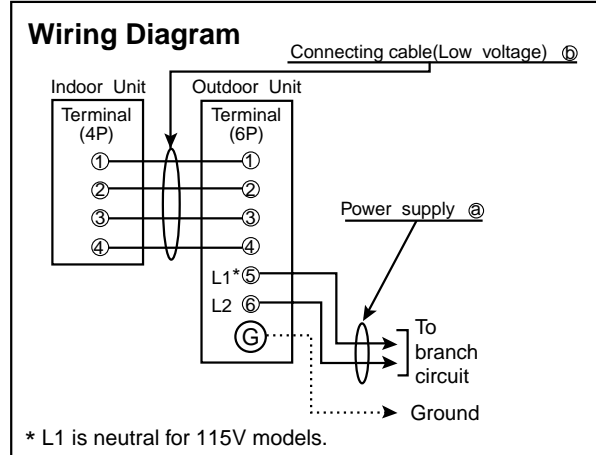

NOTE

1. shows field wiring.
2. Separately wire the high and low voltage line.
3. Use heat-proof electrical wiring capable of withstanding temperatures up to 167°F.
4. Use outdoor and waterproof connection cable rated more than 300V for the connection between indoor and outdoor unit. (For example, Type SJO-WA)

Outdoor unit

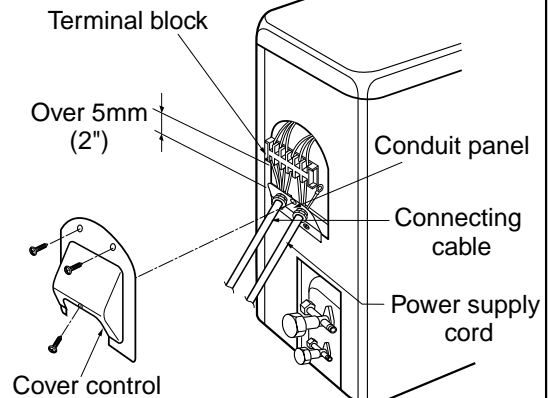

2) Connection method of the connecting cable(Example)

- (1) Dismount two-caps on the conduit panel.
- (2) Make a hole appropriate for the passage of connection cable through on cap by tool.
(for low voltage line)
- (3) Pass the connecting cable through the hole.
- (4) Properly connect the cable on the terminal block.
- (5) Fix the connection cable with clamp cord provided on the unit not to have strain at the terminal when the connection cable is pulled outside up to a 35 pound weight.
- (6) Wind the vinyl tape round the connecting cable for sealing between the surface of the connection cable and cap.
- (7) Mount the taped part of cable on the cap.
- (8) Finally, mount the holed cap with the wound cable on the conduit panel.

WARNING

Loose wiring may cause the terminal to overheat or result in unit malfunction. A fire hazard may also exist. Therefore, be sure all wiring is tightly connected.

When connecting each power wire to the corresponding terminal, follow instructions "How to connect wiring to the terminals" and fasten the wire tightly with the fixing screw of the terminal plate.

How to connect wiring to the terminals

■ For solid core wiring (or F-cable)

- (1) Cut the wire end with a wire cutter or wire-cutting pliers, then strip the insulation to expose the solid wire about 25mm(15/16")
- (2) Using a screwdriver, remove the terminal screw(s) on the terminal plate.
- (3) Using pliers, bend the solid wire to form a loop suitable for the terminal screw.
- (4) Shape the loop wire properly, place it on the terminal plate and tighten securely with the terminal screw using a screwdriver.

■ For strand wiring

- (1) Cut the wire end with a wire cutter or wire-cutting pliers, then strip the insulation to expose the strand wiring about 10mm(3/8").
- (2) Using a screwdriver, remove the terminal screw(s) on the terminal plate.
- (3) Using a round terminal fastener or pliers, securely clamp each stripped wire end with a round terminal.
- (4) Position the round terminal wire, and replace and tighten the terminal screw using a screwdriver.

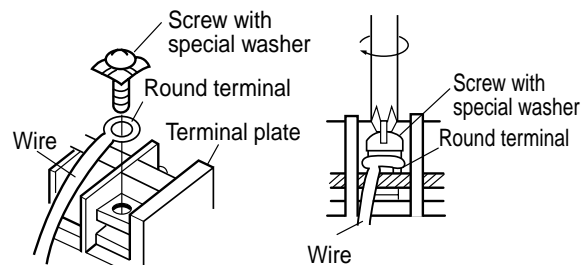
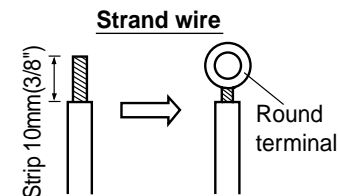
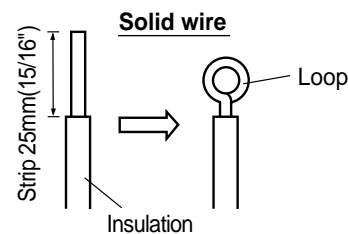
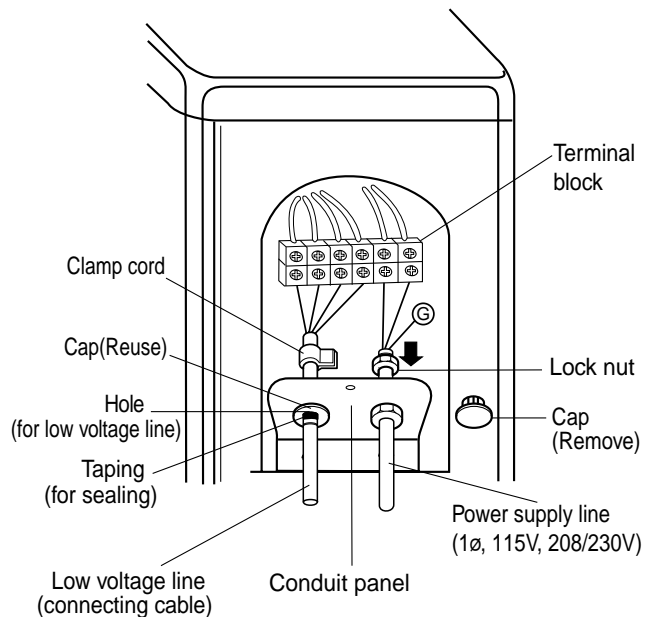

▲ CAUTION

After the confirmation of the above conditions, prepare the wiring as follows:

- 1) Never fail to have an individual power circuit specifically for the air conditioner. As for the method of wiring, be guided by the circuit diagram posted on the inside of control cover.**
- 2) The screw which fasten the wiring in the casing of electrical fittings are liable to come loose from vibrations to which the unit is subjected during the course of transportation. Check them and make sure that they are all tightly fastened. (If they are loose, it could cause burn-out of the wires.)**
- 3) Specification of power source.**
- 4) Confirm that electrical capacity is sufficient.**
- 5) Confirm that the starting voltage is maintained at more than 90 percent of the rated voltage marked on the name plate.**
- 6) Confirm that the cable thickness is as specified in the power source specification. (Particularly note the relation between cable length and thickness.)**
- 7) Always install an GFCI circuit breaker in a wet or moist area.**
- 8) The following would be caused by voltage drop.**
 - Vibration of a magnetic switch, which will damage the contact point, open fuse, disturbance of the normal function of the overload.
- 9) The means for disconnection from a power supply shall be incorporated in the fixed wiring and have an air gap contact separation of at least 3mm(0.12in) in each active(phase) conductors.**

Checking the Drainage and forming the pipings

1) Checking the drainage

1. To check the drainage.

- Pour a glass of water on the evaporator.
- Ensure the water flows through the drain hose of the indoor unit without any leakage and goes out the drain exit.

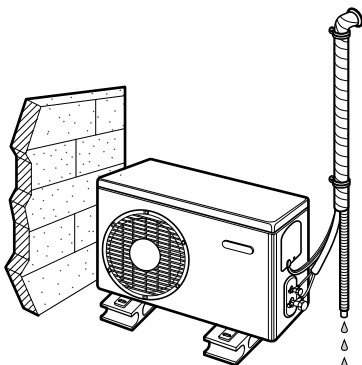
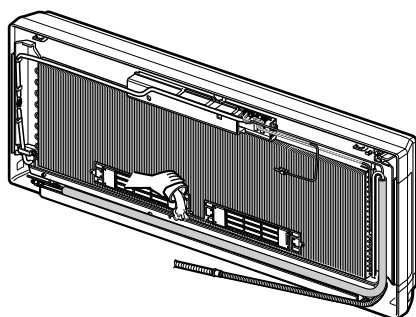

2. Drain piping

- The drain hose should point downward for easy drain flow.

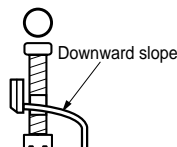

- Do not make drain piping.

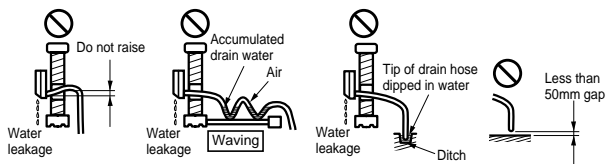

2) Form the piping

1. Form the piping by wrapping the connecting portion of the indoor unit with insulation material and secure it with two kinds of vinyl tapes.

- If you want to connect an additional drain hose, the end of the drain outlet should be routed above the ground. Secure the drain hose appropriately.

2. In cases where the outdoor unit is installed below the indoor unit perform the following.

- Tape the piping, drain hose and connecting cable from down to up.
- Secure the tapped piping along the exterior wall using saddle or equivalent.

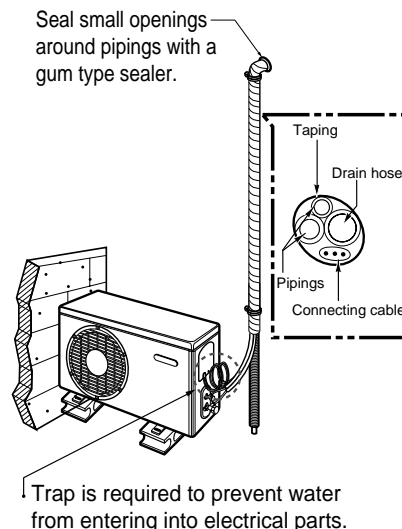

3. In cases where the Outdoor unit is installed above the Indoor unit perform the following.

- Tape the piping and connecting cable from down to up.
- Secure the taped piping along the exterior wall. Form a trap to prevent water entering the room.
- Fix the piping onto the wall by saddle or equivalent.

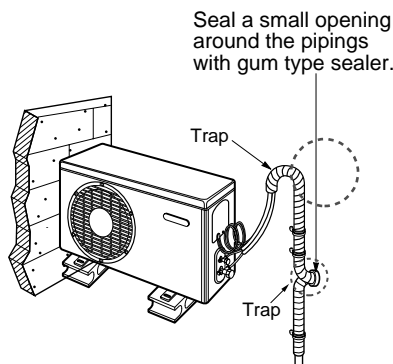

CAUTION

If a power plug is not to be used, provide a circuit breaker between power source and the unit as shown below.

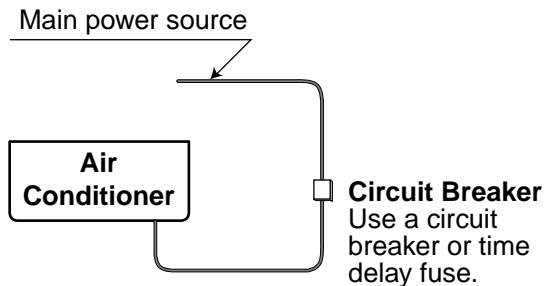

3) Connect the cable to the indoor unit

1. Connect the wires to the terminals on the control board individually according to the outdoor unit connection.

- Ensure that the color of the wires of outdoor unit and the terminal No. are the same as those of indoor unit respectively.
(Refer to Wiring diagram on page16.)



WARNING

- Be sure to refer to the wiring diagram label inside the grille and carry out the correct field wiring.
Wrong wiring can cause the unit to misoperate to result in a fire hazard.
- Check local electrical codes and any specified wiring instructions or limitations.

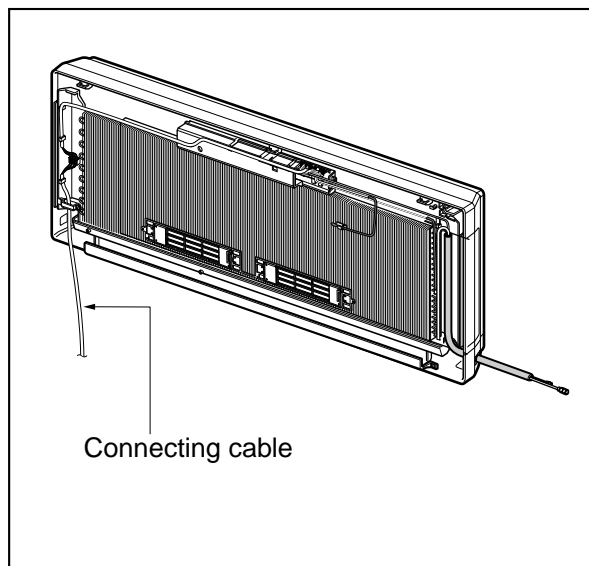

Air Purging

1) Air purging

Air and moisture remaining in the refrigerant system have undesirable effects as indicated below.

- Pressure in the system rises.
- Operating current rises.
- Cooling(or heating) efficiency drops.
- Moisture in the refrigerant circuit may freeze and block capillary tubing.
- Water may lead to corrosion of parts in the refrigeration system.

Therefore, the indoor unit and tubing between the indoor and outdoor unit must be leak tested and evacuated to remove any noncondensables and moisture from the system.

2) Air purging with vacuum pump

1. Preparation

- Check that each tube(both liquid and gas side tubes) between the indoor and outdoor units have been properly connected and all wiring for the test run has been completed. Remove the service valve caps from both the gas and the liquid side on the outdoor unit. Note that both the liquid and the gas side service valves on the outdoor unit are kept closed at this stage.

2. Leak test

- Connect the manifold valve(with pressure gauges) and dry nitrogen gas cylinder to this service port with charge hoses.

CAUTION

Be sure to use a manifold valve for air purging. If it is not available, use a stop valve for this purpose. The "Hi" knob of the manifold valve must always be kept close.

- Pressurize the system to no more than 150 P.S.I.G. with dry nitrogen gas and close the cylinder valve when the gauge reading reached 150 P.S.I.G. Next, test for leaks with liquid soap.

CAUTION

To avoid nitrogen entering the refrigerant system in a liquid state, the top of the cylinder must be higher than its bottom when you pressurize the system. Usually, the cylinder is used in a vertical standing position.

- Do a leak test of all joints of the tubing(both indoor and outdoor) and both gas and liquid side service valves. Bubbles indicate a leak. Be sure to wipe off the soap with a clean cloth.
- After the system is found to be free of leaks, relieve the nitrogen pressure by loosening the charge hose connector at the nitrogen cylinder. When the system pressure is reduced to normal, disconnect the hose from the cylinder.

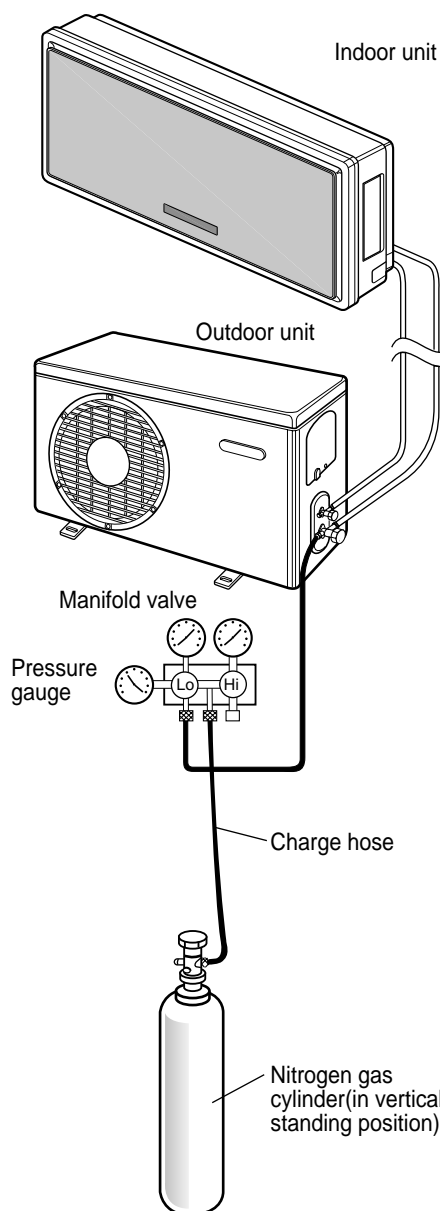

Soap water method

- (1) Remove the caps from the 2-way and 3-way valves.
- (2) Remove the service-port cap from the 3-way valve.
- (3) To open the 2-way valve turn the valve stem counterclockwise approximately 90°, wait for about 2~3 sec, and close it.
- (4) Apply a soap water or a liquid neutral detergent on the indoor unit connection or outdoor unit connections by a soft brush to check for leakage of the connecting points of the piping.
- (5) If bubbles come out, the pipes have leakage.

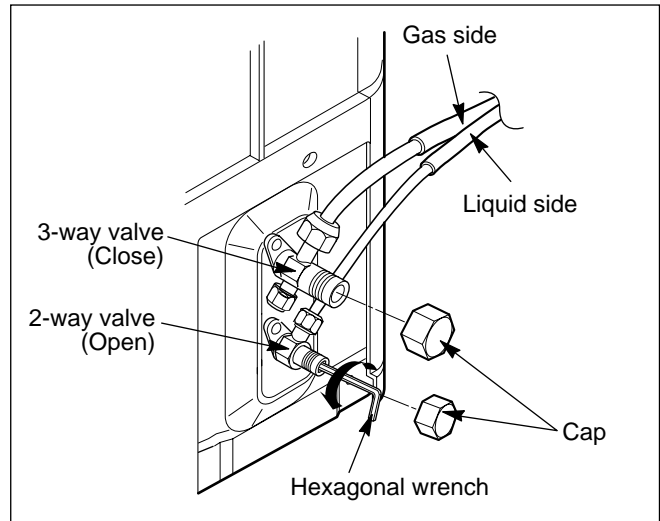

3. Evacuation

- Connect the charge hose end described in the preceding steps to the vacuum pump to evacuate the tubing and indoor unit.
- Confirm the "Lo" knob of the manifold valve is open. Then, run the vacuum pump.
- The operation time for evacuation varies with tubing length and capacity of the pump. The following table shows the time required for evacuation.

Required time for evacuation when 30 gal/h vacuum pump is used	
If tubing length is less than 10m (33 ft)	if tubing length is longer than 10m (33 ft)
10 min. or more	15 min. or more

- When the desired vacuum is reached, close the "Lo" knob of the manifold valve and stop the vacuum pump.

4. Finishing the job

- With a service valve wrench, turn the valve stem of liquid side valve counter-clockwise to fully open the valve.
- Turn the valve stem of gas side valve counter-clockwise to fully open the valve.
- Loosen the charge hose connected to the gas side service port slightly to release the pressure, then remove the hose.
- Replace the flare nut and its bonnet on the gas side service port and fasten the flare nut securely with an adjustable wrench. This process is very important to prevent leakage from the system.
- Replace the valve caps at both gas and liquid side service valves and fasten them tight.

This completes air purging with a vacuum pump. The air conditioner is now ready to test run.

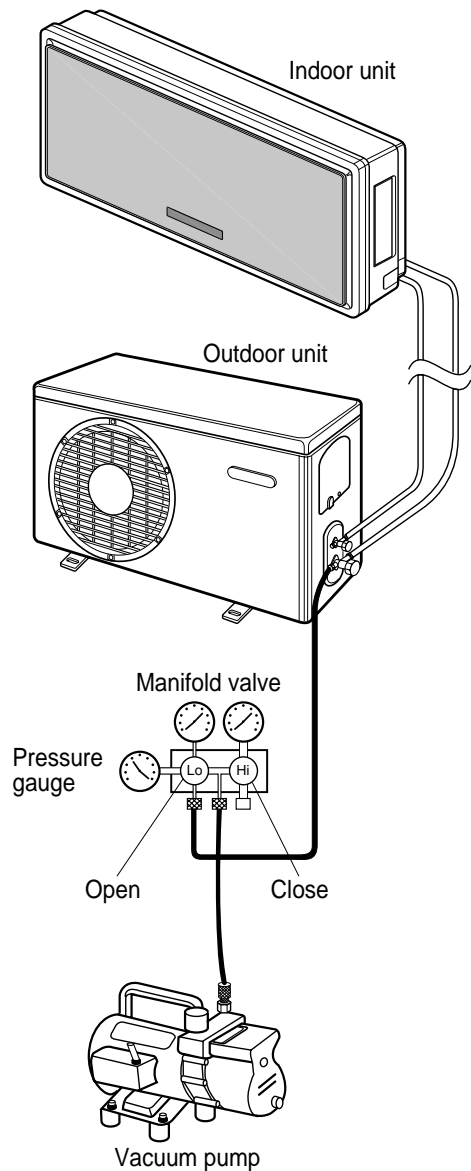

Panel Front Assembly

1. First, Check the side cover assembly exactly, Fix power cord in the bottom groove of cover side left.

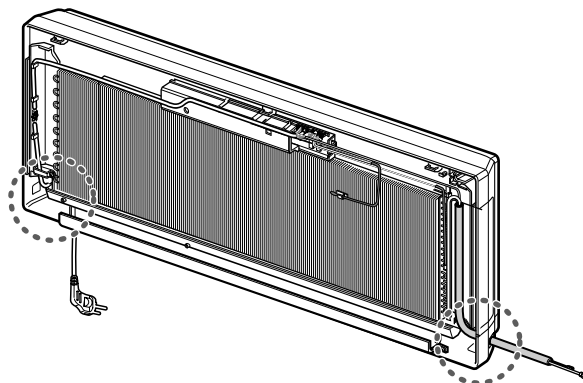

2. Assemble connecting lead wire with controller and first fix the upper part of panel front, then match the lower part of panel front

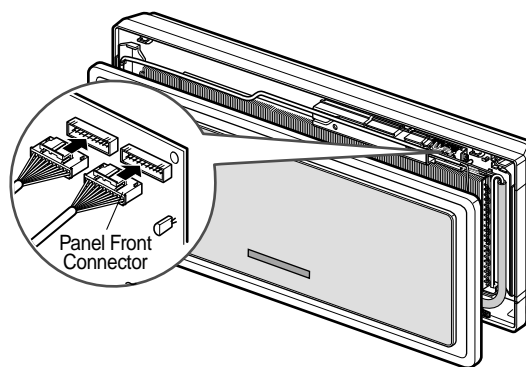

3. Drive three screws.

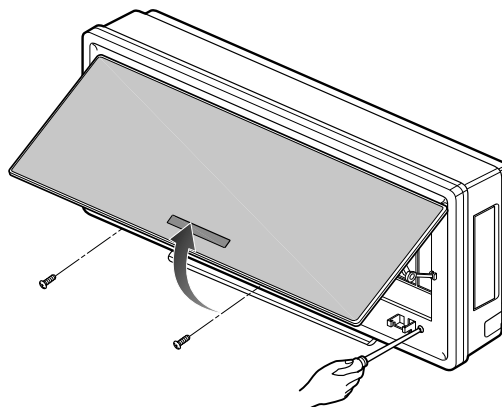

Test Running

1. Check that all tubing and wiring have been properly connected.
2. Check that the gas and liquid side service valves are fully open.

1. Prepare remote control

1. Remove the battery cover by pulling it according to the arrow direction.
2. Insert new batteries making sure that the (+) and (-) of battery are installed correctly.
3. Reattach the cover by pushing it back into position.

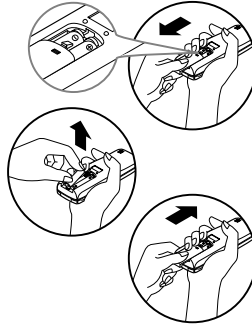

NOTE:

- Use 2 AAA(1.5volt) batteries. Do not use rechargeable batteries.
- Remove the batteries from the remote control if the system is not going to be used for a long time.

2. Settlement of outdoor unit

- Anchor the outdoor unit with a bolt and nut(ø10mm) tightly and horizontally on a concrete or rigid mount.
- When installing on the wall, roof or rooftop, anchor the mounting base securely with a nail or wire assuming the influence of wind and earthquake.
- In the case when the vibration of the unit is conveyed to the hose, secure the unit with an anti-vibration bushing.

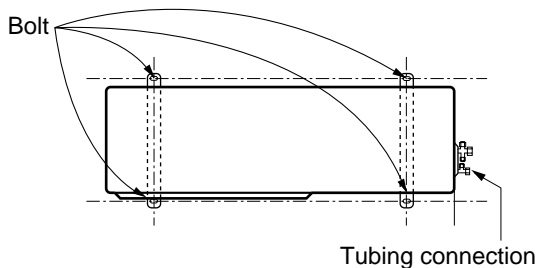

3. Evaluation of the performance

Operate unit for 15~20 minutes, then check the system refrigerant charge:

1. Measure the pressure of the gas side service valve.
2. Measure the temperature of the intake and discharge of air.
3. Ensure the difference between the intake temperature and the discharge is more than 8°C(46°F) (Cooling) or (Heating).

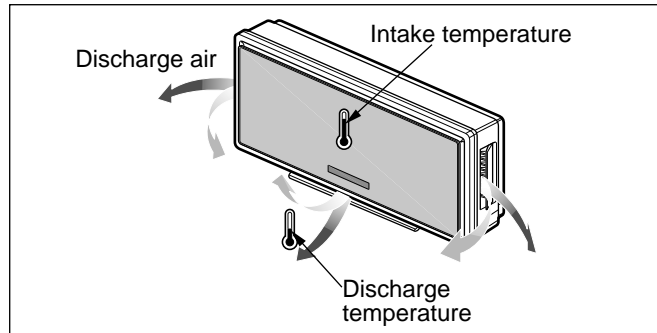

4. For reference; the gas side pressure of optimum condition is as below.(Cooling)

Refrigerant	Outside ambient TEMP.	The pressure of the gas side service valve.
R-410A	35°C (95°F)	8.5~9.5kg/cm ² G(120~135 P.S.I.G)

- NOTE:** If the actual pressure is higher than shown, the system is most likely over-charged, and charge should be removed. If the actual pressure are lower than shown, the system is most likely undercharged, and charge should be added.

The air conditioner is now ready for use.

PUMP DOWN

This is performed when the unit is to be relocated or the refrigerant circuit is serviced.

Pump Down means collecting all refrigerant in the outdoor unit without loss in refrigerant gas.

CAUTION:

Be sure to perform Pump Down procedure with the unit cooling mode.

Pump Down Procedure

1. Connect a low-pressure gauge manifold hose to the charge port on the gas side service valve.
2. Open the gas side service valve halfway and purge the air from the manifold hose using the refrigerant gas.
3. Close the liquid side service valve(all the way in).
4. Turn on the unit's operating switch and start the cooling operation.
5. When the low-pressure gauge reading becomes 1 to 0.5kg/cm² G(14.2 to 7.1 P.S.I.G.), fully close the gas side valve stem and then quickly turn off the unit. At that time, Pump Down has been completed and all refrigerant gas will have been collected in the outdoor unit.

Operation

Remote Control Operations

The controls will look like the following.

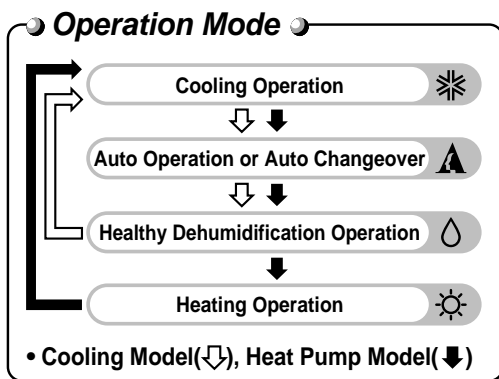
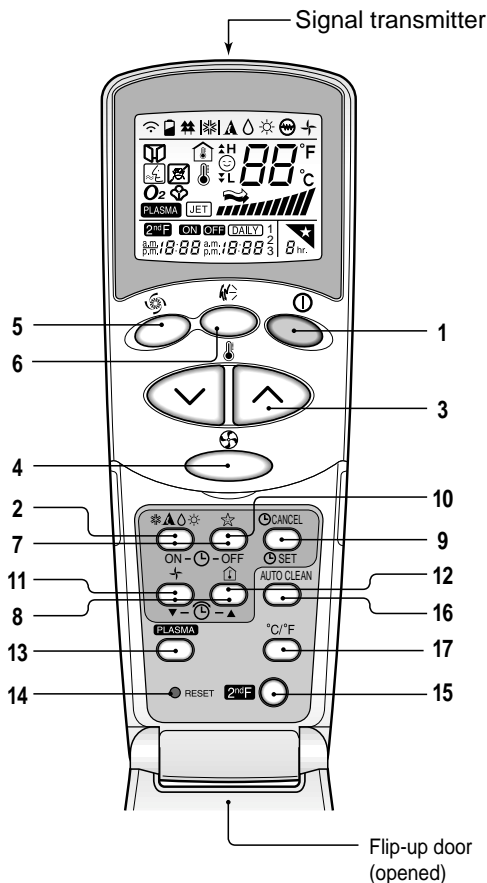

1. START/STOP BUTTON

Operation starts when this button is pressed and stops when the button is pressed again.



2. OPERATION MODE SELECTION BUTTON

Used to select the operation mode.



3. ROOM TEMPERATURE SETTING BUTTONS

Used to select the room temperature.

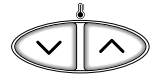

4. INDOOR FAN SPEED SELECTOR

Used to select fan speed in four steps low, medium, high and CHAOS.



5. JET COOL

Used to start or stop the speed cooling.(speed cooling operates super high fan speed in cooling mode.)



6. CHAOS SWING BUTTON

Used to stop or start louver movement and set the desired up/down airflow direction.



7. ON/OFF TIMER BUTTONS

Used to set the time of starting and stopping operation.

8. TIME SETTING BUTTONS

Used to adjust the time.

9. TIMER SET/CANCEL BUTTON

Used to set the timer when the desired time is obtained and to cancel the Timer operation.

10. SLEEP MODE AUTO BUTTON

Used to set Sleep Mode Auto operation.

11. AIR CIRCULATION BUTTON

Used to circulate the room air without cooling or heating.

12. ROOM TEMPERATURE CHECKING BUTTON

Used to check the room temperature.

13. NEO PLASMA(OPTIONAL)

Used to start or stop the plasma-purification function.

14. RESET BUTTON

Used prior to resetting time.

15. 2nd F Button

Used prior to using modes printed in blue at the bottom of buttons.

16. AUTO CLEAN (OPTIONAL)

Used to set Auto Clean mode.

17. °C TO °F SWITCHING BUTTON

Used to switch temperature reading from Centigrade to Fahrenheit.

Disassembly of the parts (Indoor unit)

Warning :

Disconnect the unit from power supply before making any checks.
Be sure the power switch is set to "OFF".

1. To remove the Grille from the Chassis.

- Push mark [▽] on the grille bottom then pull it down and remove 3 securing screws.
- Lift the both lower parts of panel front.
- After pull down this panel a bit, separate connecting wire with product.

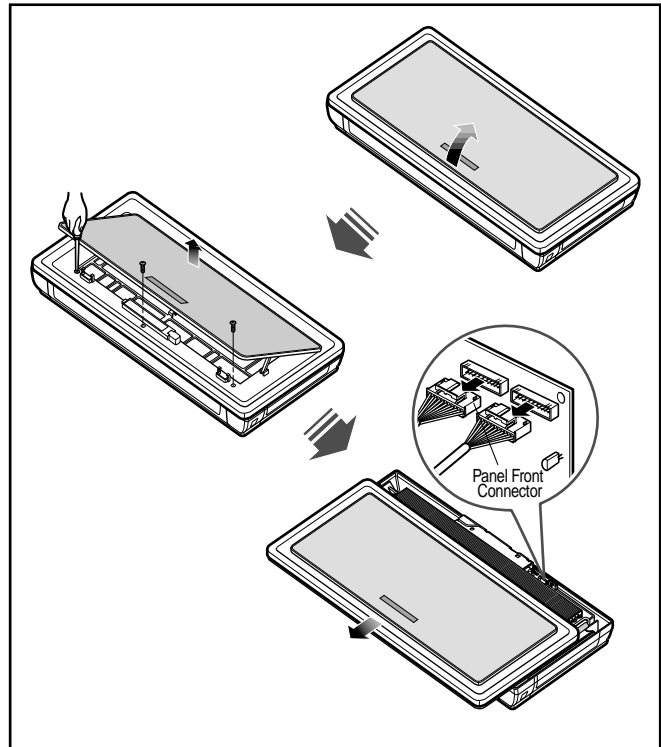

2. To remove the Control Box.

- Before removing the control box, be sure to disconnect the wires from PWB.
- Pull the cover control out from the control box and disconnect other wires.
- Remove securing screws.
- Pull the control box out from the chassis carefully.

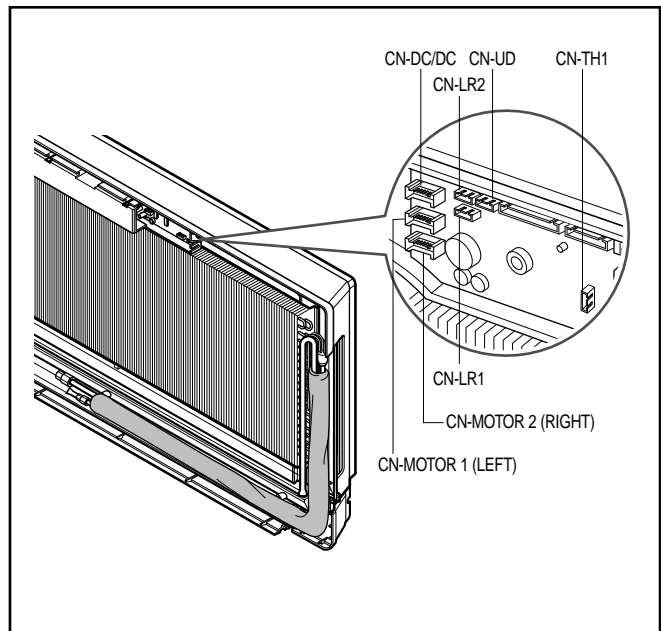

3. To remove the Evaporator.

- Remove 1 screws securing the evaporator.
- Pull the evaporator out from the chassis carefully.

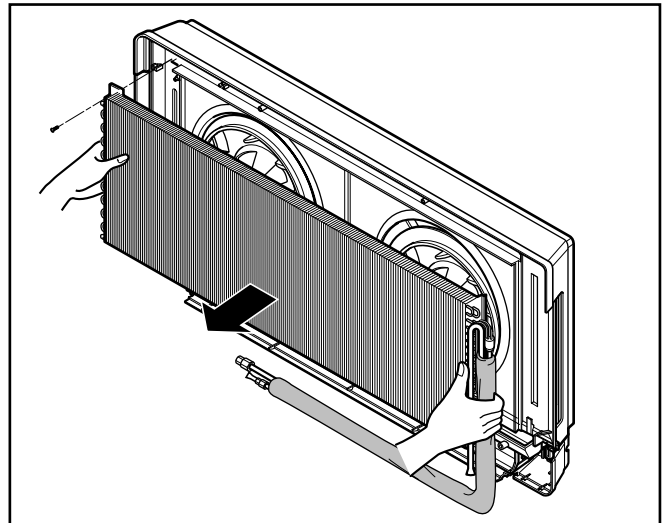

4. Before removing the Turbo Fan.

- Remove the securing screws from the chassis.
- Pull the pipe cover, top cover and the air guide.

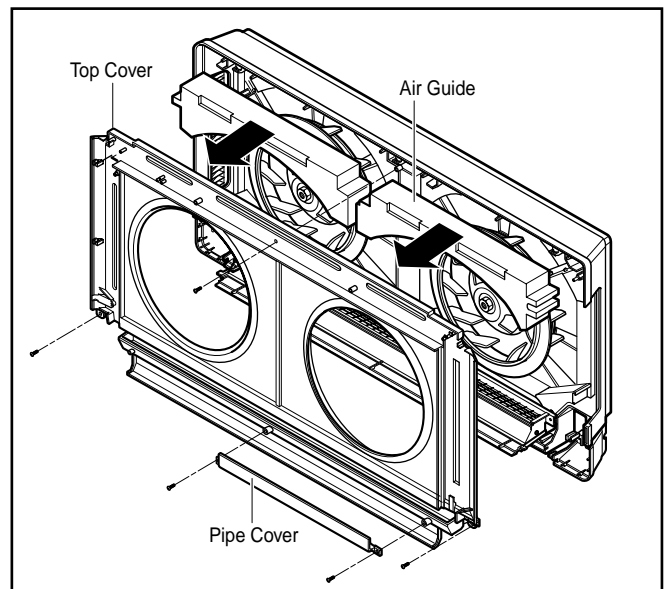

5. To remove the Motor.

- Remove the securing bolt from the motor shaft.
- Pull the fan out from the motor shaft.
- Remove 4 screws securing motor mount from the chassis and lift up the motor mount and the bracket.

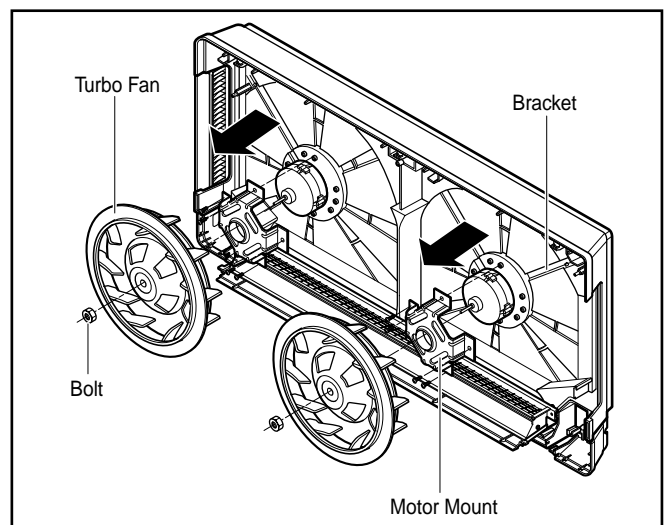

2-way, 3-way Valve

		2-way Valve (Liquid Side)	3-way Valve (Gas Side)	
Works		Shaft position	Shaft position	Service port
Shipping		Closed (with valve cap)	Closed (with valve cap)	Closed (with cap)
1.	Air purging (Installation)	Open (counter-clockwise)	Closed (clockwise)	Open (push-pin or with vacuum pump)
Operation		Open (with valve cap)	Open (with valve cap)	Closed (with cap)
2.	Pumping down (Transferring)	Closed (clockwise)	Open (counter-clockwise)	Open (connected manifold gauge)
3.	Evacuation (Servicing)	Open	Open	Open (with charging cylinder)
4.	Gas charging (Servicing)	Open	Open	Open (with charging cylinder)
5.	Pressure check (Servicing)	Open	Open	Open (with charging cylinder)
6.	Gas releasing (Servicing)	Open	Open	Open (with charging cylinder)

1. Air purging

Required tools : hexagonal wrench, adjustable wrench, torque wrenches, wrench to hold the joints, and gas leak detector.

The additional gas for air purging has been charged in the outdoor unit.

However, if the flare connections have not be done correctly and there gas leaks, a gas cylinder and the charge set will be needed.

The air in the indoor unit and in the piping must be purged. If air remains in the refrigeration pipes, it will affect the compressor, reduce to cooling capacity, and could lead to a malfunction.

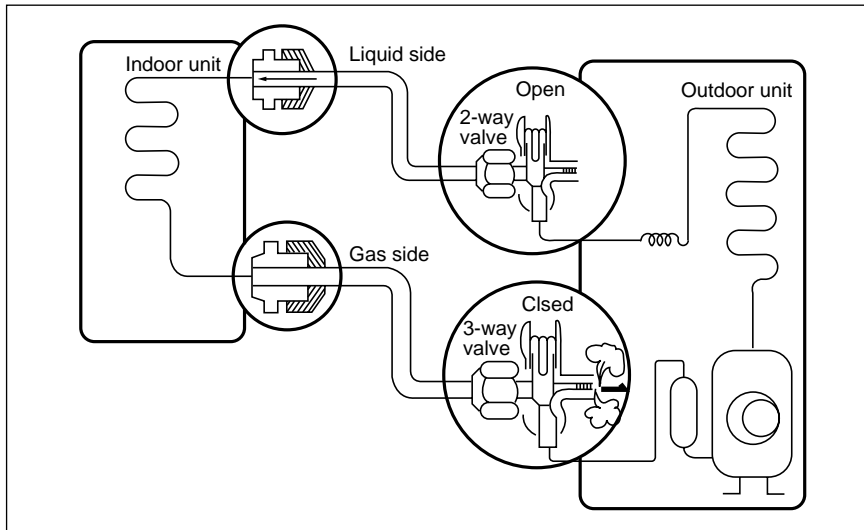

Service port nut:

Be sure, using a torque wrench to tighten the service port nut (after using the service port), so that it prevents the gas leakage from the refrigeration cycle.

* **CAUTION : Do not leak the gas in the air during Air purging.**

• Procedure

nut to a torque of 1.8kg.cm.

- (1) Recheck the piping connections.
- (2) Open the valve stem of the 2-way valve counterclockwise approximately 90°, wait 10 seconds, and then set it to closed position.
 - Be sure to use a hexagonal wrench to operate the valve stem.
- (3) Check for gas leakage.
 - Check the flare connections for gas leakage.
- (4) Purge the air from the system.
 - Set the 2-way valve to the open position and remove the cap from the 3-way valve's service port.
 - Using the hexagonal wrench to press the valve core pin, discharge for three seconds and then wait for one minute. Repeat this three times.
- (5) Use torque wrench to tighten the service port

⚠ Caution

If gas leakage are discovered in step (3) above, take the following mesures :

If the gas leaks stop when the piping connections are tightened further, continue working from step (4). If the gas leaks do not stop when the connections are retightened, repair the location of the leak, discharge all of the gas through the service port, and then recharge with the specified amount of gas from a gas cylinder.

2. Pumping down

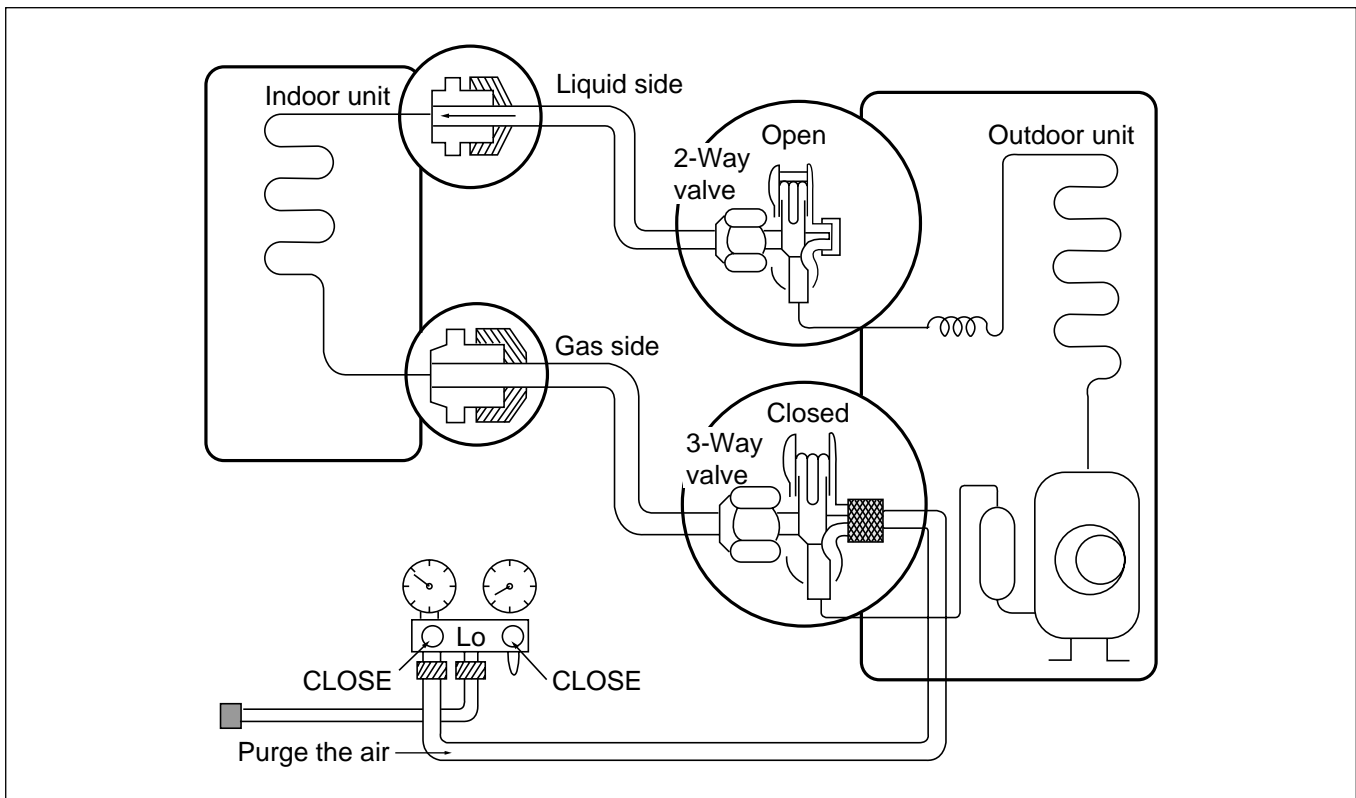

• Procedure

(1) Confirm that both the 2-way and 3-way valves are set to the open position.

- Remove the valve stem caps and confirm that the valve stems are in the raised position.
- Be sure to use a hexagonal wrench to operate the valve stems.

(2) Operate the unit for 10 to 15 minutes.

(3) Stop operation and wait for 3 minutes, then connect the charge set to the service port of the 3-way valve.

- Connect the charge hose with the push pin to the service port.

(4) Air purging of the charge hose.

- Open the low-pressure valve on the charge set slightly to air purge from the charge hose.

(5) Set the 2-way valve to the closed position.

(6) Operate the air conditioner at the cooling cycle and stop it when the gauge indicates $1\text{kg}/\text{cm}^2\text{g}$.

(7) Immediately set the 3-way valve to the closed position.

- Do this quickly so that the gauge ends up indicating 3 to $5\text{kg}/\text{cm}^2\text{g}$.

(8) Disconnect the charge set, and mount the 2-way and 3-way valve's stem nuts and the service port nut.

- Use torque wrench to tighten the service port nut to a torque of 1.8 kg.m .
- Be sure to check for gas leakage.

⚠ CAUTION

Do not use the existing charge set for R-22. It is necessary to use new charge set for R-410A. The pressure of R-410A is 1.6 times higher than that of R-22. Thus, the high pressure side gauge of charge set should be used higher pressure gauge of $50\text{kg}/\text{cm}^2$ range.

1) Re-air purging

(Re-installation)

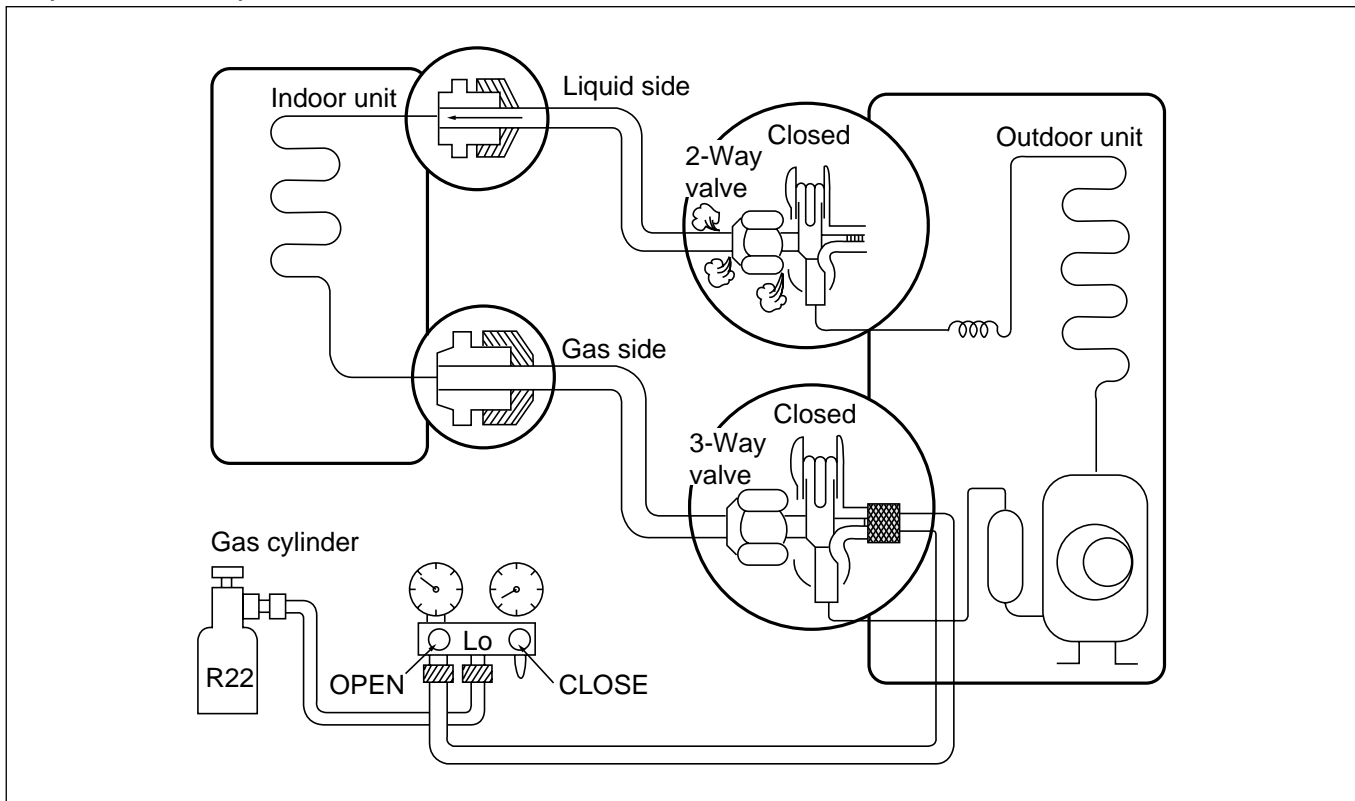

• Procedure

- (1) Confirm that both the 2-way valve and the 3-way valve are set to the closed position.
 - (2) Connect the charge set and a gas cylinder to the service port of the 3-way valve.
 - Leave the valve on the gas cylinder closed.
 - (3) Air purging.
 - Open the valves on the gas cylinder and the charge set. Purge the air by loosening the flare nut on the 2-way valve approximately 45° for 3 seconds then closing it for 1 minute; repeat 3 times.
 - After purging the air, use a torque wrench to tighten the flare nut on the 2-way valve.
 - (4) Check for gas leakage.
 - Check the flare connections for gas leakage.
 - (5) Discharge the refrigerant.
 - Close the valve on the gas cylinder and discharge the refrigerant until the gauge indicates 3 to 5 kg/cm²g.
 - (6) Disconnect the charge set and the gas cylinder, and set the 2-way and 3-way valves to the open position.
 - Be sure to use a hexagonal wrench to operate the valve stems.
 - (7) Mount the valve stem nuts and the service port nut.
 - Use torque wrench to tighten the service port nut to a torque of 1.8 kg.m.
 - Be sure to check for gas leakage.
- * **▲ CAUTION:**
Do not leak the gas in the air during Air Purging.

2) Balance refrigerant of the 2-way, 3-way valves

(Gas leakage)

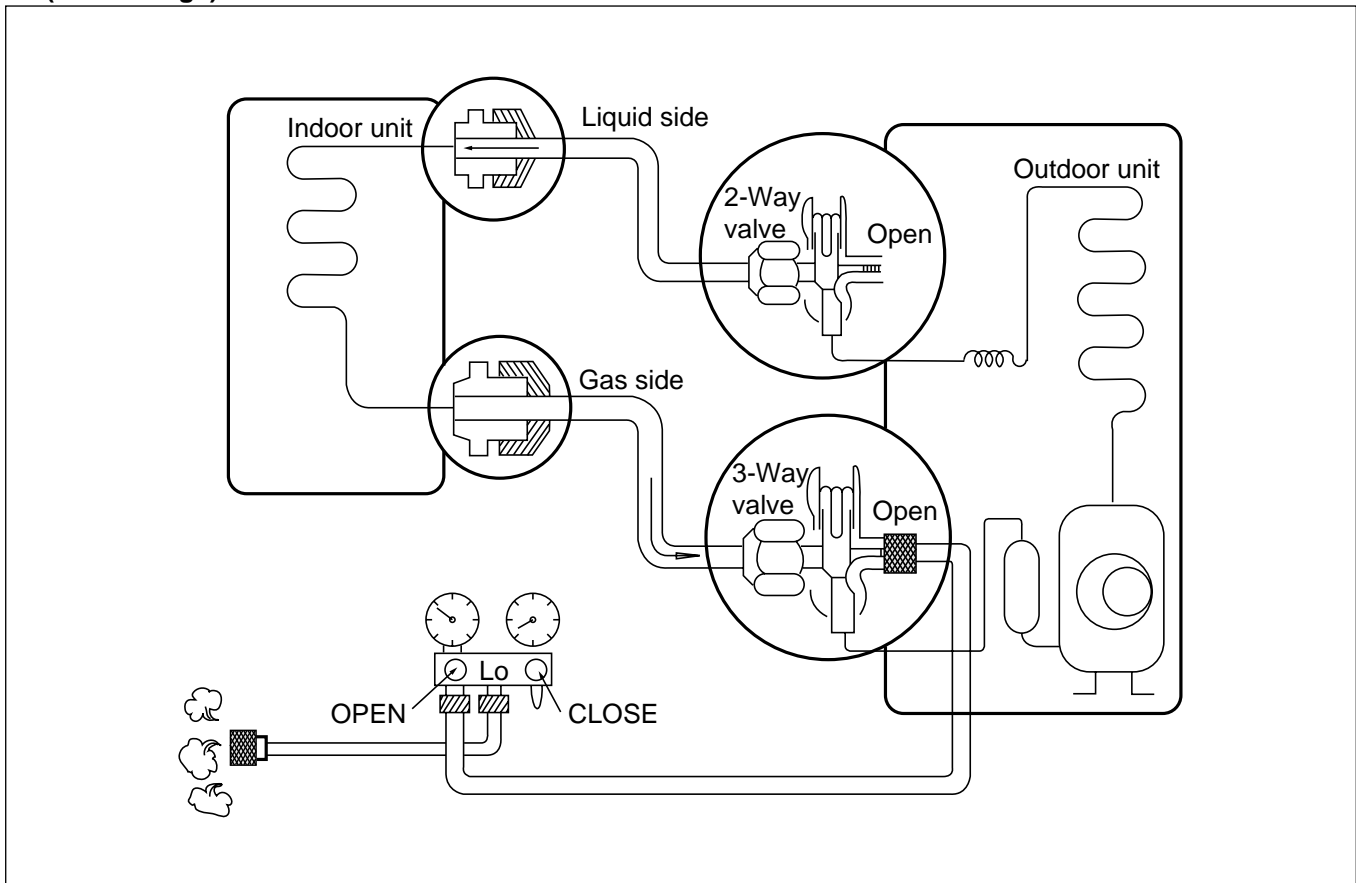

• Procedure

(1) Confirm that both the 2-way and 3-way valves are set to the back seat.

(2) Connect the charge set to the 3-way valve's port.

- Leave the valve on the charge set closed.
- Connect the charge hose with the push pin to the service port.

(3) Open the valve (Lo side) on the charge set and discharge the refrigerant until the gauge indicates 0 kg/cm²G.

- If there is no air in the refrigerant cycle (the pressure when the air conditioner is not running is higher than 1 kg/cm²G), discharge the refrigerant until the gauge indicates 0.5 to 1 kg/cm²G. If this is the case, it will not be necessary to apply a vacuum.
- Discharge the refrigerant gradually; if it is discharged too suddenly, the refrigeration oil will also be discharged.

3. Evacuation

(All amount of refrigerant leaked)

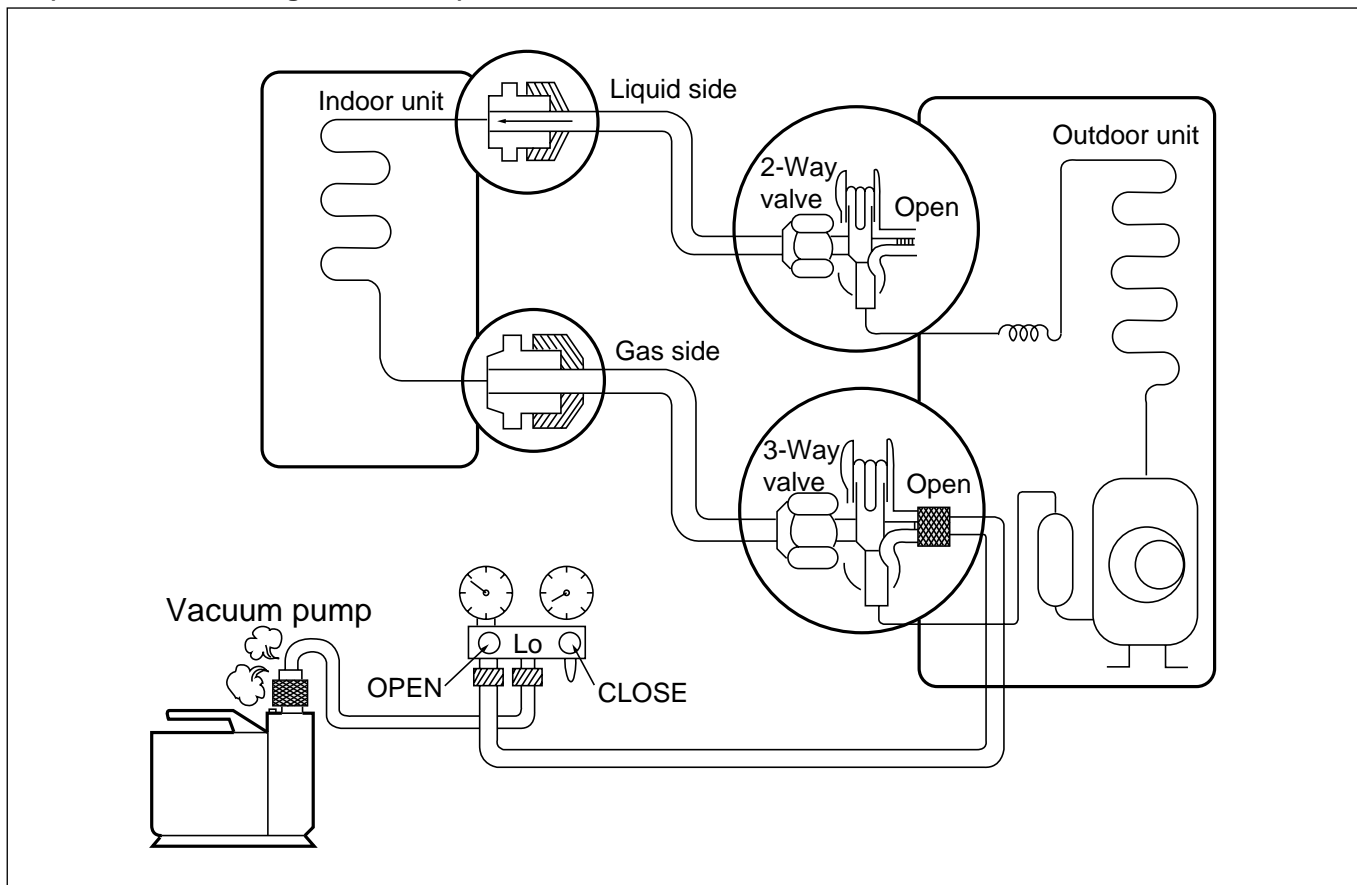

• Procedure

- (1) Connect the vacuum pump to the charge set's center hose
- (2) Evacuation for approximately one hour.
 - Confirm that the gauge needle has moved toward -76 cmHg (vacuum of 4 mmHg or less).
- (3) Close the valve (Lo side) on the charge set, turn off the vacuum pump, and confirm that the gauge needle does not move (approximately 5 minutes after turning off the vacuum pump).
- (4) Disconnect the charge hose from the vacuum pump.
 - Vacuum pump oil.
If the vacuum pump oil becomes dirty or depleted, replenish as needed.

▲ CAUTION

Use vacuum pump equipped with check valve applied to be prevented from flowing backward.

4. Gas Charging

(After Evacuation)

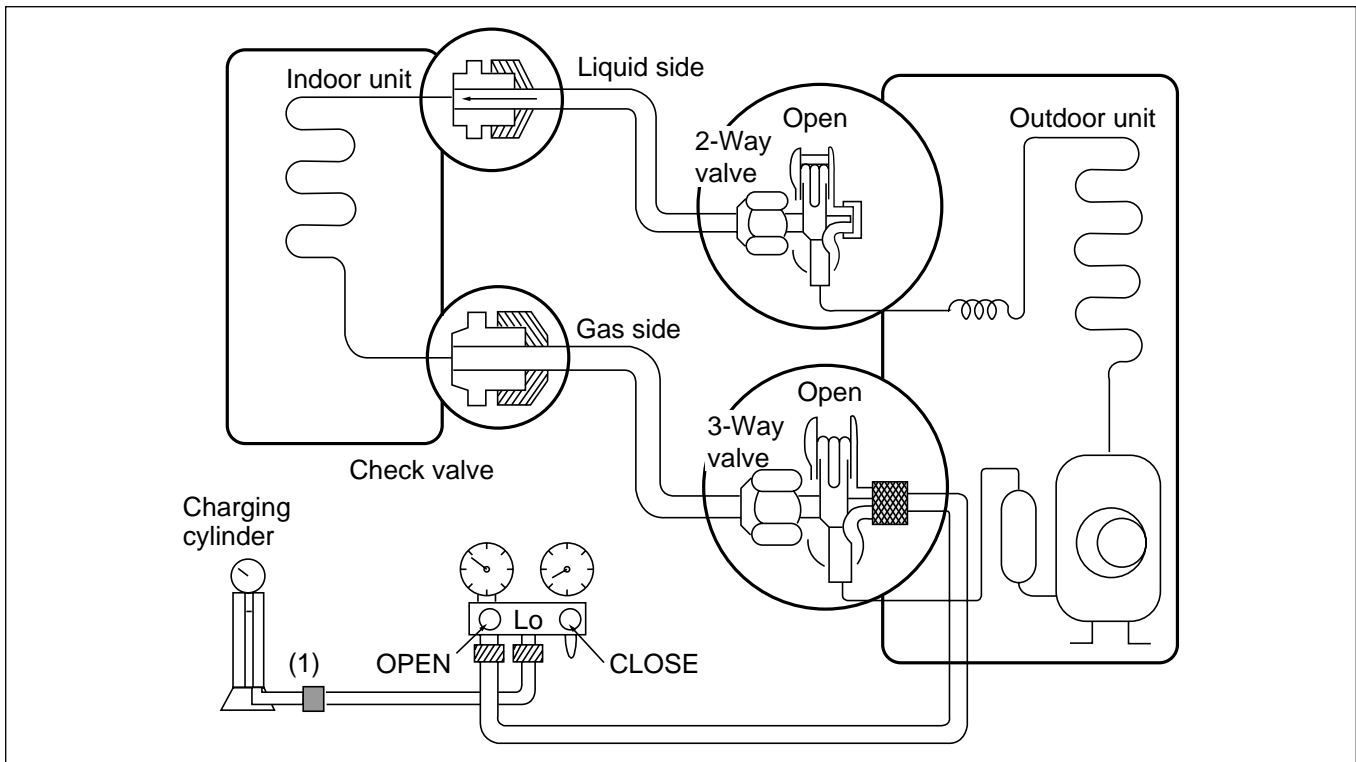

• Procedure

(1) Connect the charge hose to the charging cylinder.

- Connect the charge hose which you disconnected from the vacuum pump to the valve at the bottom of the cylinder.
- If you are using a gas cylinder, also use a scale and reverse the cylinder so that the system can be charged with liquid.

(2) Purge the air from the charge hose.

- Open the valve at the bottom of the cylinder and press the check valve on the charge set to purge the air. (Be careful of the liquid refrigerant). The procedure is the same if using a gas cylinder.

(3) Open the valve (Lo side on the charge set and charge the system with liquid refrigerant.

- If the system can not be charged with the specified amount of refrigerant, it can be charged with a little at a time (approximately 150g each time) while operating the air conditioner in the cooling cycle; however, one time is not sufficient, wait approximately 1 minute and then repeat the procedure (pumping down-pin).

This is different from previous procedures.

Because you are charging with liquid refrigerant from the gas side, absolutely do not attempt to charge with larger amounts of liquid refrigerant while operating the air conditioner.

(4) Immediately disconnect the charge hose from the 3-way valve's service port.

- Stopping partway will allow the gas to be discharged.
- If the system has been charged with liquid refrigerant while operating the air conditioner turn off the air conditioner before disconnecting the hose.

(5) Mount the valve stem nuts and the service port nut.

- Use torque wrench to tighten the service port nut to a torque of 1.8 kg.m.
- Be sure to check for gas leakage.

▲ CAUTION

This unit is charged with R-410A.
Pay attention not to charge R-22.

Additional gas charging

(Gas leakage)

- When refrigerant is insufficient by leakage, recharge the unit with the refrigerant up to normal operating suction pressure.
- Use the graph or the equation below to get operating suction pressure according to indoor and outdoor temperature.

Suction pressure was measured at 3-way valve service port after operating the unit for 10 minutes.

The method of using graph

- Find outdoor temperature.
- Find indoor temperature onto the curve of outdoor temperature.
- Read suction pressure at the axis of ordinates.

The method of using equation

- Calculate suction pressure after putting indoor and outdoor temperature into the equation.

Operating Suction Pressure (For R410A) (According to Indoor & Outdoor Temperature)

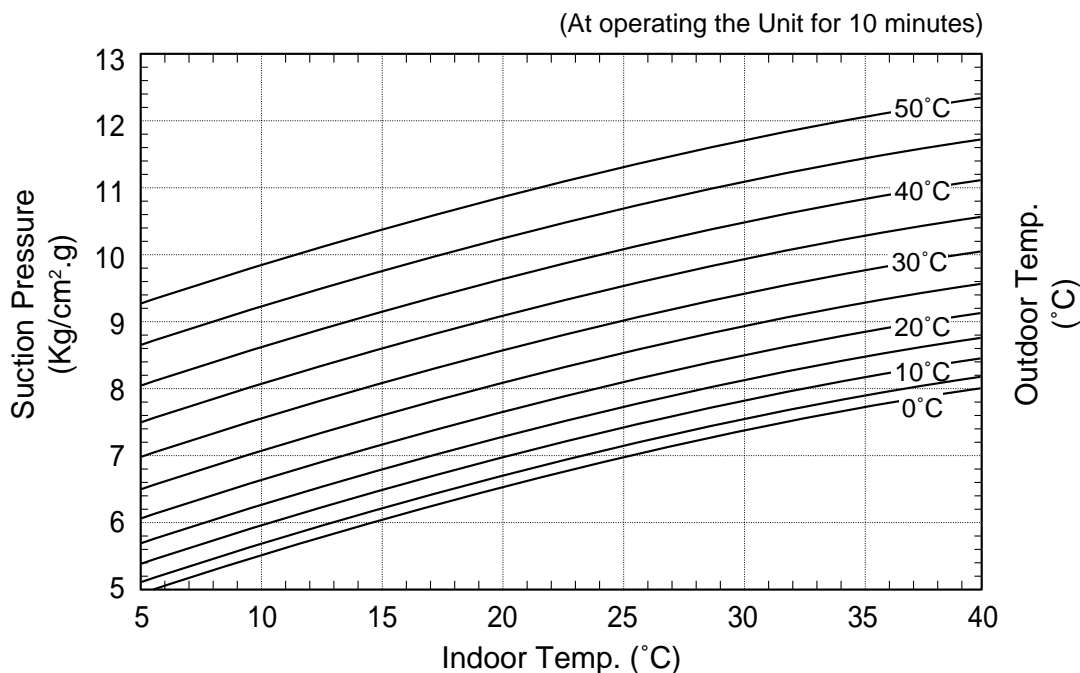

$$P = 3 + 0.0123 \times T_{out}^{1.5} + 0.8 \times T_{in}^{0.5}$$

Where, P : Suction Pressure(kg/cm².g)
 Tout : Outdoor Temperature(°C)
 Tin : Indoor Temperature(°C)

Cycle Troubleshooting Guide

1. Trouble analysis

1. Check temperature difference between intake and discharge air and operating current.

Temp. Difference	Temp. difference :approx. 0°F Current :less than 80% of rated current	All amount of refrigerant leaked out. Check refrigeration cycle.
	Temp. difference :approx. 8°C(14°F) Current :less than 80% of rated current	Refrigerant leakage Clog of refrigeration cycle Defective compressor
Operating Current	Temp. difference :less than 8°C(14°F) Current :less than 80% of rated current	Excessive amount of refrigerant
	Temp. difference :over 8°C(14°F)	Normal

Notice:

Temperature difference between intake and discharge air depends on room air humidity. When the room air humidity is relatively higher, temperature difference is smaller. When the room air humidity is relatively lower temperature difference is larger.

2. Check temperature and pressure of refrigeration cycle.

Suction pressure (Compared with the normal value)	Temperature (Compared with the normal value)	Cause of Trouble	Description
Higher	High	Defective compressor Defective 4-way reversing valve	Current is low.
	Normal	Excessive amount of refrigerant	High pressure does not quickly rise at the beginning of operation.
Lower	Higher	Insufficient amount of refrigerant(Leakage) Clogging	Current is low. Current is low.

Notice:

1. The suction pressure is usually 8.5~9.5 kg/cm²G at normal condition.
2. The temperature can be measured by attaching the thermometer to the low pressure tubing and wrap it with putty.

2. Product does not operate at all.

(* Refer to Electronic Control Device drawing and Schematic diagram.)

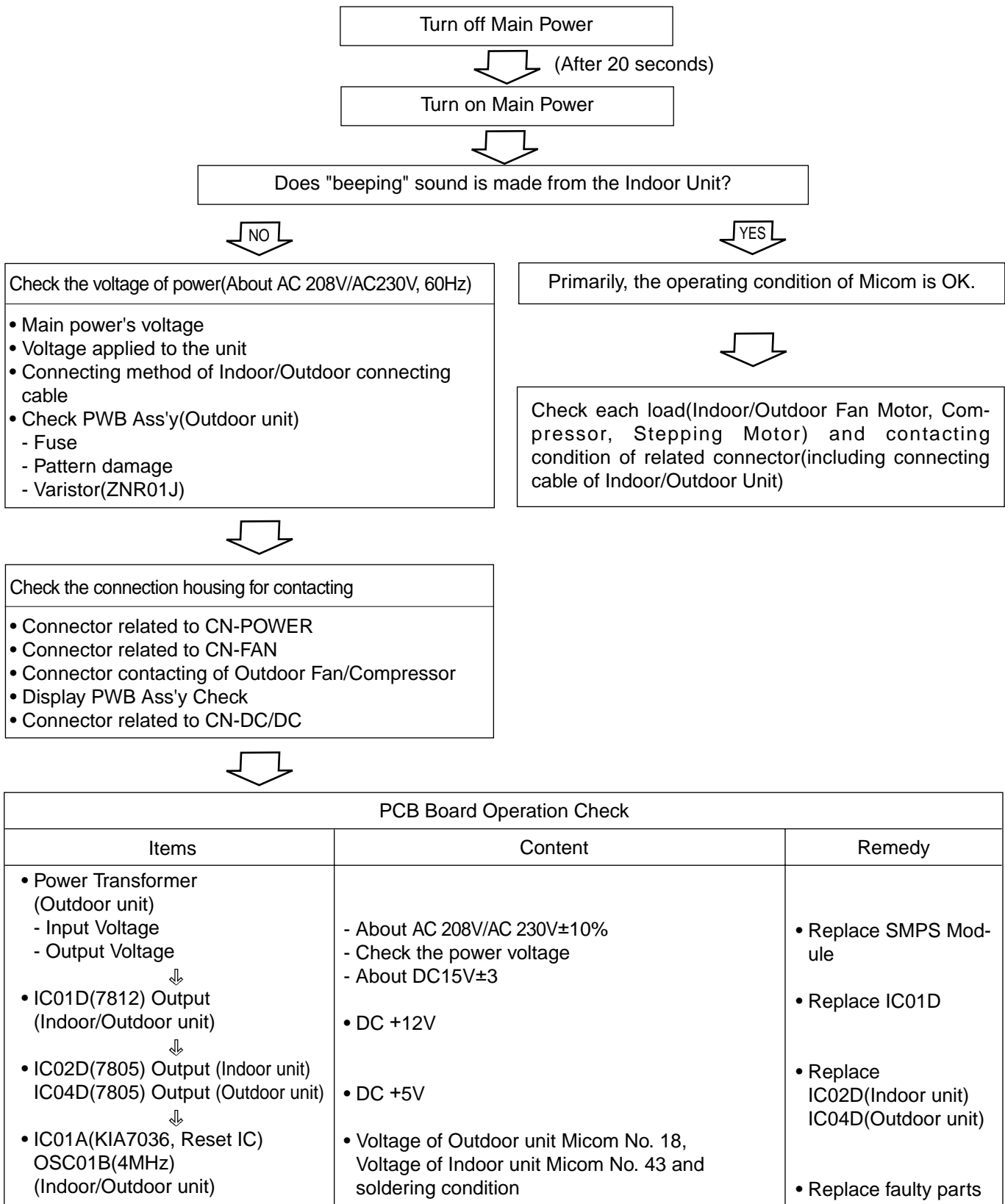

3. The product is not operate with the remote controller.

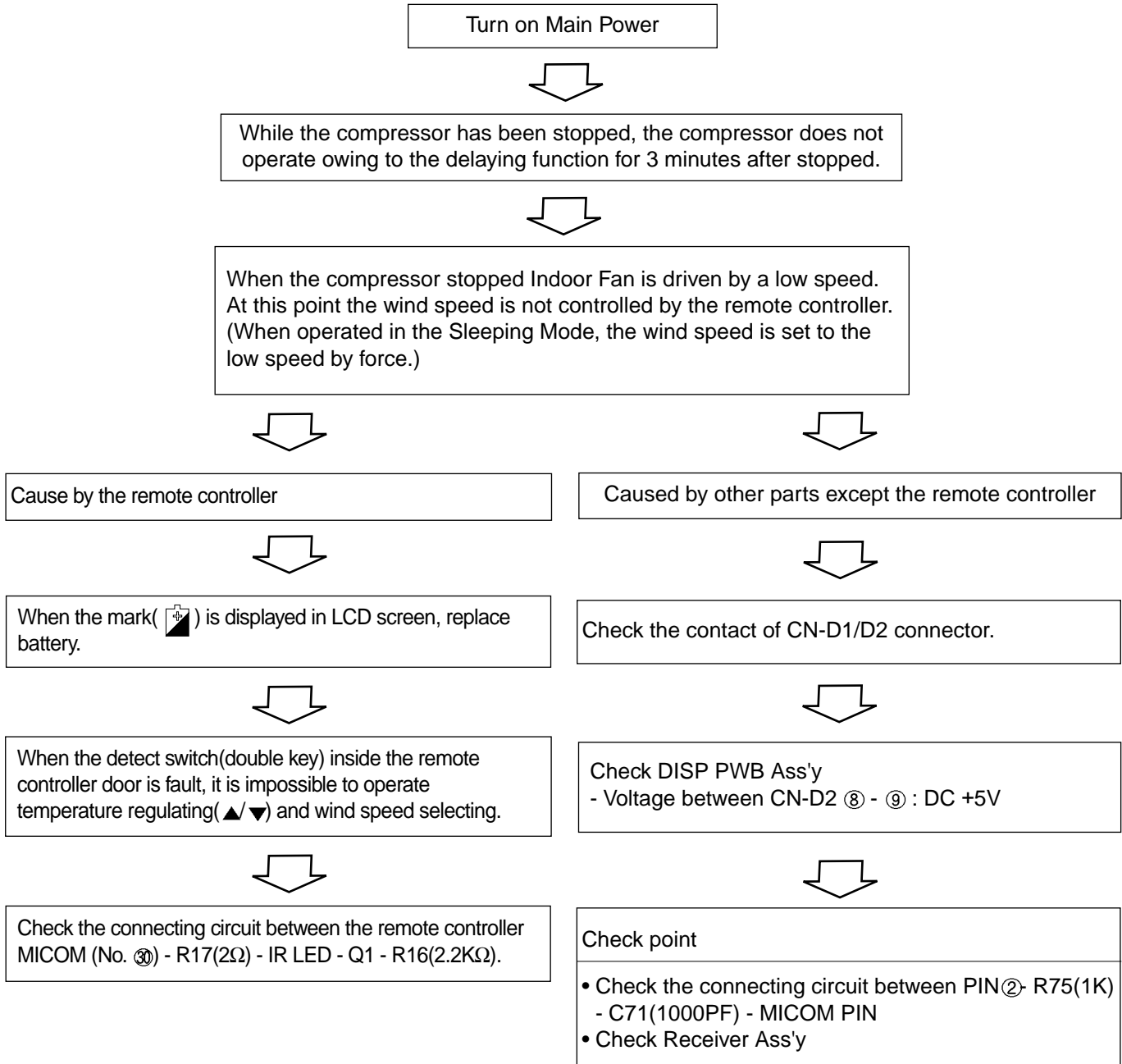

4. Compressor/Outdoor Fan are unable to drive.

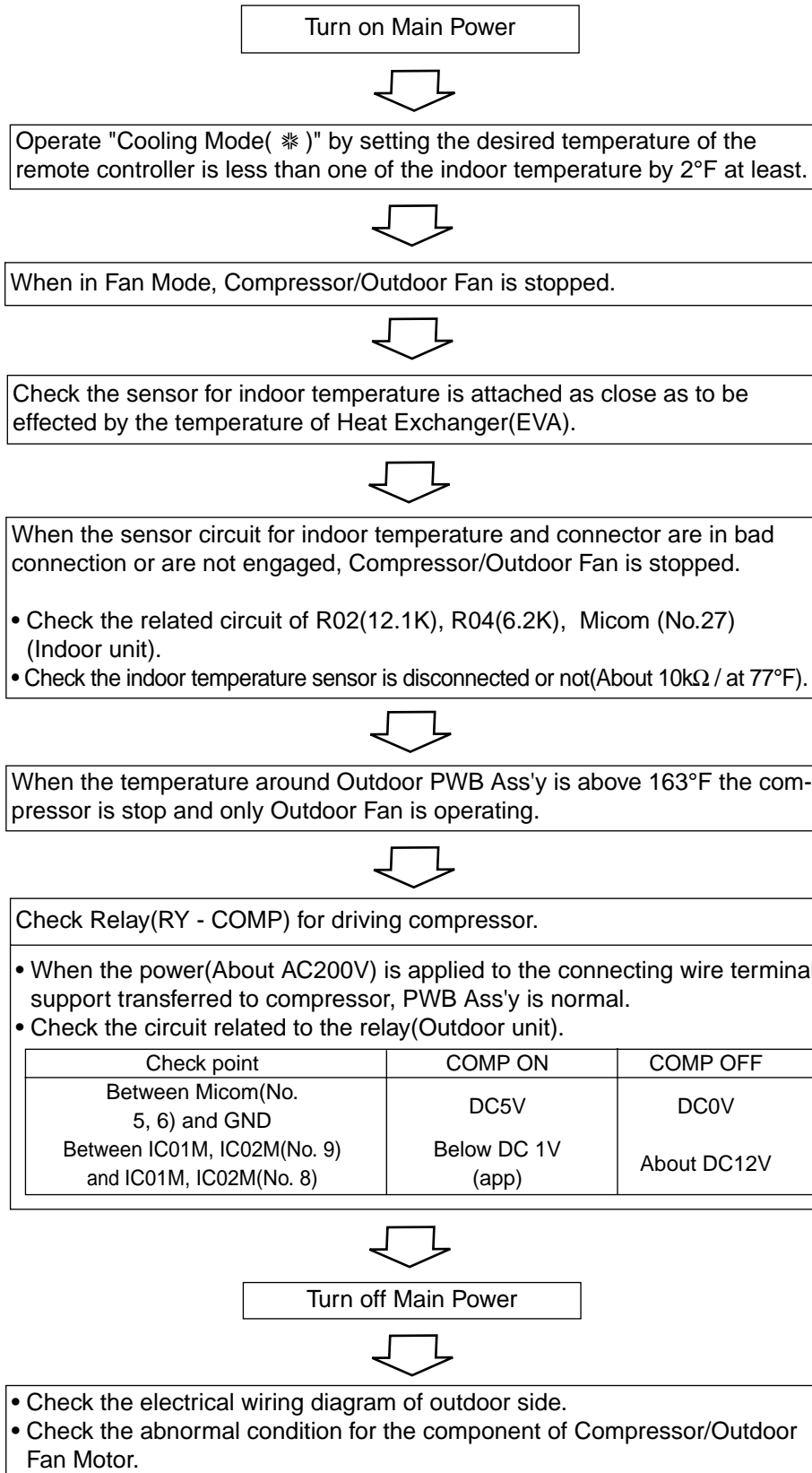

5. When Indoor Fan does not operate.

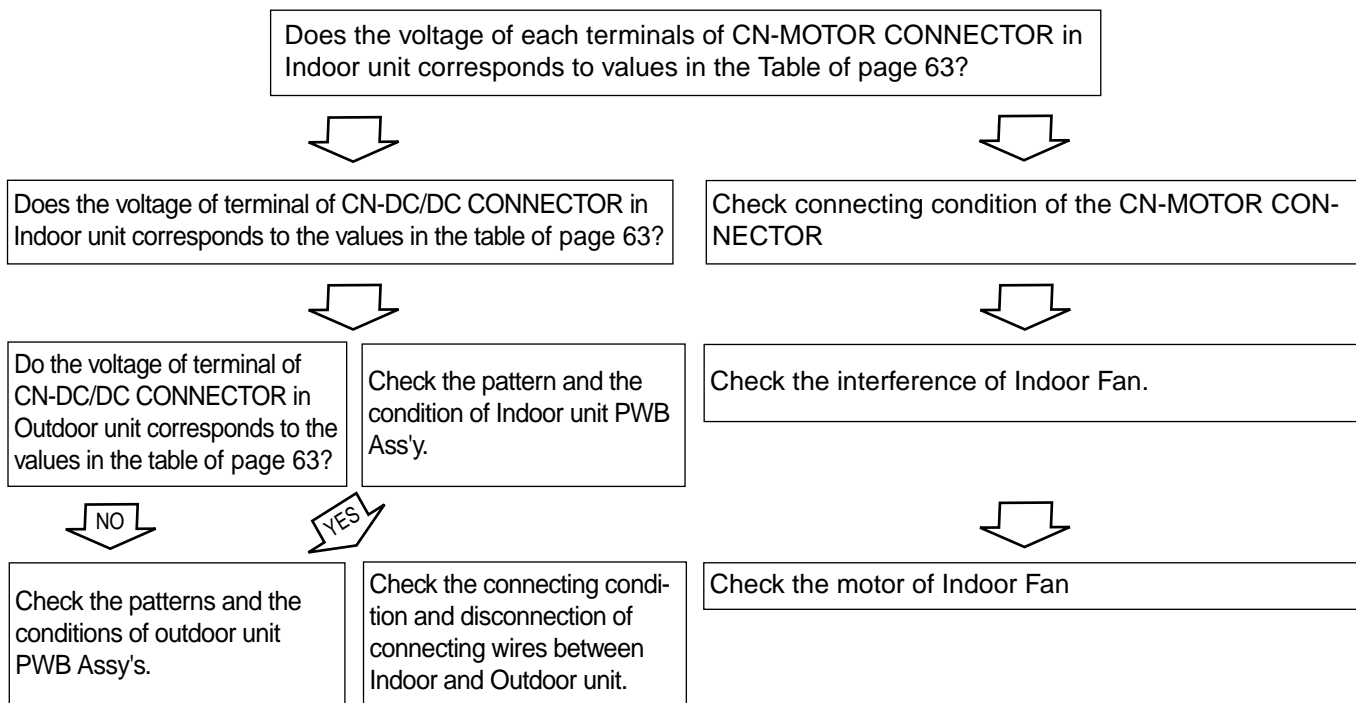

- ※ Indoor Fan may be stopped in the Soft Dry Mode(change to the Cooling Operation Mode).
- ※ Indoor Fan is to be stopped when Indoor pipe(coil) temperature is lower than 79°F.
(At that times, Defrost indicator is turned on)

6. When Vertical Louver does not operate.

- Confirm that the Vertical Louver is normally geared with the shaft of Stepping Motor.
- If the regular torque is detected when rotating the Vertical Louver with hands ⇒ Normal



- Check the connecting condition of CN-U/D, CN-L/R Connector
- Check the soldering condition(on PWB) of CN-U/D, CN-L/R Connector



Check the operating circuit of the Vertical Louver

- Confirm that there is DC +12V between pin ②(RE D) of CN-U/D, CN-L/R and GND.
- Confirm that there is a soldering short at following terminals.
 - Between ⑥②, ⑥①, ⑥⑦ and ⑥⑨ of MICOM
 - Between ⑥⑦, ⑥⑥, ⑥⑤ and ⑥④ of MICOM
 - Between ⑥①, ⑥⑦, ④⑨ and ④⑧ of MICOM
 - Between ①, ②, ③, ④ and ⑤ of CN-U/D, CN-L/R



If there are no problems after above checks

- Confirm the assembly conditions that are catching and interfering parts in the rotation radial of the Vertical Louver

7. When a communication error occurs.

- The operation indicator of Indoor unit blinks five times.
- The red indicator of Outdoor unit blinks five times.



Check the connecting wires between Indoor and Outdoor unit for the connecting error and the contacting condition.



Check the installation condition of outdoor unit.



Check for the communication error and the operating condition of product after also operating with the remote controller, then taking above 2 minutes.



Apply the power again after about 20 seconds by the power of Outdoor unit is off.



Check for the communication error and the operating condition of product after also operating with the remote controller, then taking above 2 minutes.



Check the PWB assembly of Indoor and Outdoor unit.

Caution: If the connecting wires of Indoor and Outdoor unit are not connected within 2 minutes after the power of Outdoor unit is applied, a communication error will occur. Therefore, the power should be applied after connecting them.

8. The phenomena in case of connecting error

INDOOR UNIT

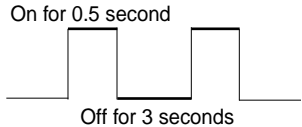
Connector Type	Condition	Phenomena
CN-DC/DC <div style="border: 1px solid black; padding: 2px; display: inline-block;"> ① ② ③ ④ </div> ① Blue ② Black ③ Brown ④ Red	Open and connecting error	<ul style="list-style-type: none"> The same as the phenomenon of Outdoor Unit.
CN-MOTOR	Open	<ul style="list-style-type: none"> The indoor fan does not operate. The operation indicator of Indoor unit blinks 8 times.
CN-UD	Open	<ul style="list-style-type: none"> The up/down vane does not operate.
	Short between terminals	<ul style="list-style-type: none"> The up/down vane does not smoothly operate.
CN-D1/D2	Open	<ul style="list-style-type: none"> It does not operate with a remote controller.
CN-TH	Open	<ul style="list-style-type: none"> The operation indicator blinks once. <div style="text-align: center;">  <p>On for 0.5 second</p> <p>Off for 3 seconds</p> </div> <ul style="list-style-type: none"> The compressor and the outdoor fan stop. The indoor fan speed is low.
	Short between terminals (③ and ④) of ROOM-TH.	<ul style="list-style-type: none"> The operation indicator blinks once (on for 0.5 second, off for 3 seconds). The compressor operates continuously regardless of the setting temperature and the variation of room temperature.
	Short between terminals (① and ②) of PIPE-TH.	<ul style="list-style-type: none"> The operation indicator blinks once (on for 0.5 second, off for 3 seconds) Continuous operation

OUTDOOR UNIT

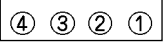
Connector Type	Condition	Phenomena
CN-POWER	OPEN	<ul style="list-style-type: none"> All functions stop. The operation with the remote controller, forced and test one do not operate.
	Connecting reversely	<ul style="list-style-type: none"> PWB pattern is damaged when applying the power.
RY-COMP terminal	OPEN	<ul style="list-style-type: none"> All functions stop or the compressor does not operate. The operation with the remote controller, forced and test one do not operate.
	Connecting reversely	<ul style="list-style-type: none"> All functions stop. The operation with the remote controller, forced and test one do not operate.
CN-TRANS	OPEN	<ul style="list-style-type: none"> All functions stop. The operation with the remote controller, forced and test one do not operate.
CN-FAN	OPEN	<ul style="list-style-type: none"> The Indoor Fan does not operate.
The connecting wire of CN-DC/DC, and Indoor and Outdoor Unit  ① Blue ② Black ③ Brown ④ Red	OPEN	<ul style="list-style-type: none"> All functions stop. The operation with the remote controller, forced and test one do not operate.
	Connecting error (① ↔ ②)	<ul style="list-style-type: none"> The only signal of remote controller operation/stop is inputted, but the product does not operate. The RED indicator of outdoor unit blinks 5 times after 2 minutes with applying the power.
	Connecting error (① ↔ ③)	<ul style="list-style-type: none"> The beep sound, such as "beep, beep, beep, beep, beep", occurs periodically in Indoor unit. The signal input of a remote controller and operation of product is impossible. The RED indicator blinks 5 times after 2 minutes with applying the power.
	Connecting error (① ↔ ④)	<ul style="list-style-type: none"> The signal of remote controller is inputted, but the product does not operate. The RED indicator of outdoor unit and the operation indicator of indoor one blinks 5 times after 2 minutes with applying the power.
	Connecting error (② ↔ ③)	<ul style="list-style-type: none"> No power for Indoor unit. The signal input of the remote controller and operation of product is impossible. The thermal protector of the Power Trans operates when let it alone for long time.
	Connecting error (② ↔ ④)	<ul style="list-style-type: none"> The signal of the remote controller is inputted. The fuse and Q61 in the Outdoor unit are damaged when the indoor fan is operated.
	Connecting error (③ ↔ ④)	<ul style="list-style-type: none"> No power for Indoor unit. The signal input of the remote controller and operation of product is impossible. The RED indicator of the Outdoor unit blinks 5 times after 2 minutes with applying the power.

9. Voltage of Connectors according to Indoor Fan Speed

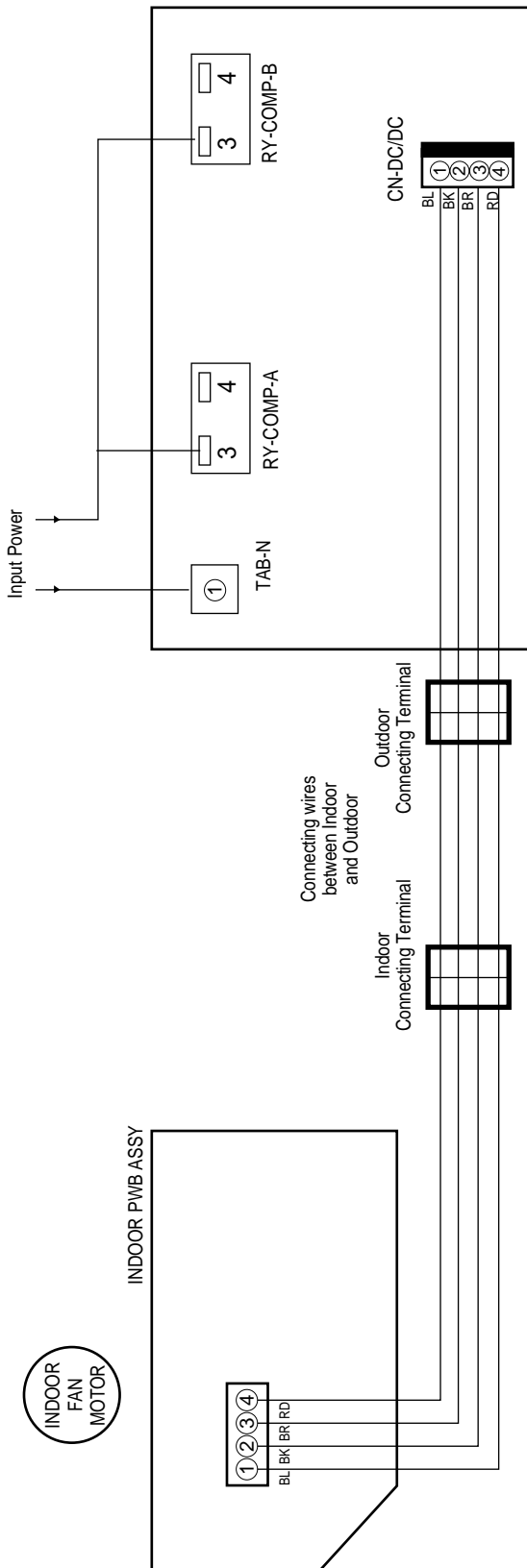

MODELS	No. of pins		18K				
			DC Voltage(±10%)				
CONNELTORS	+	-	S-Hi	Hi	Med	Low	Off
INDOOR CN-MOTOR	1	2	34.0	32.0	27.8	24.1	0.0
	3	2	5.0	5.0	5.0	5.0	5.0
	4	2	0~5	0~5	0~5	0~5	5.0
INDOOR CN-DC/DC	1	2	0~12	0~12	0~12	0~12	0~12
	3	2	17.0	17.0	17.0	17.0	17.0
	4	2	34.0	32.0	27.8	24.1	0.0
OUTDOO R CN-DC/DC	1	2	0~12	0~12	0~12	0~12	0~12
	3	2	17.0	17.0	17.0	17.0	17.0
	4	2	34.0	32.0	27.8	24.1	0.0

Electronic Control Device

MAIN PWB ASSY(Indoor Unit)

• TOP VIEW

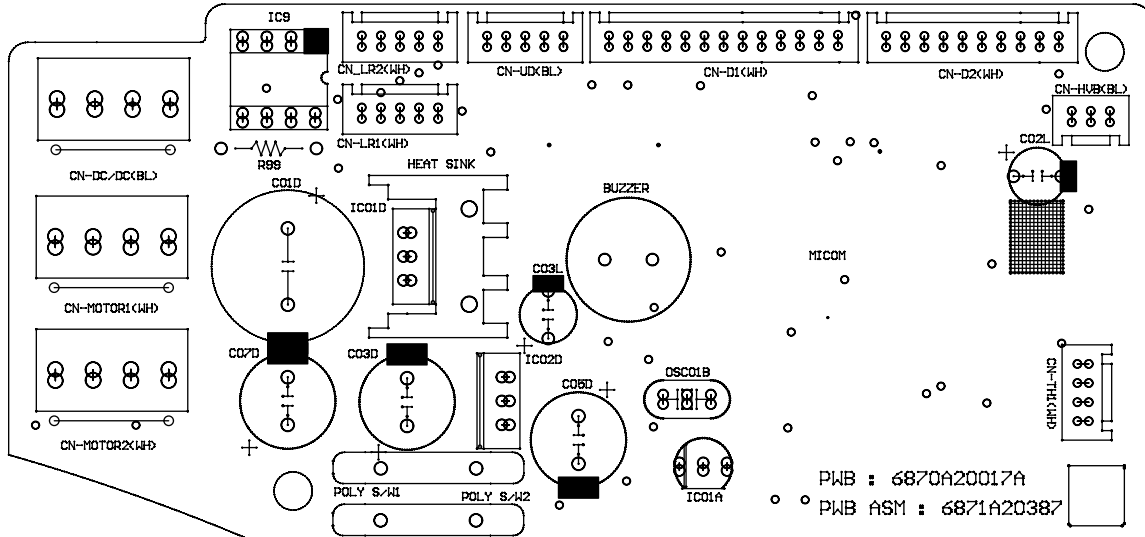

• BOTTOM VIEW

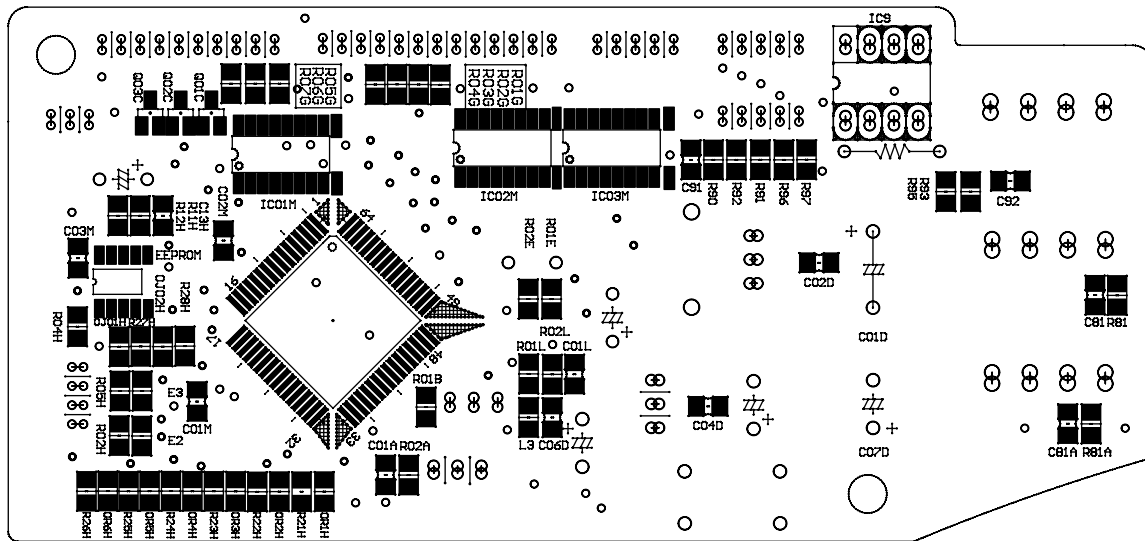

• PWB ASSY SVC PART LIST

NO	MODEL	P/No.	OPTIONAL FUNCTION					
			OR1H	OR2H	OR3H	OR4H	OR5H	OR6H
1	18K Cooling Model	6871A20387J	12K	20K	27K	12K	OPEN	OPEN\

OJ1H, OJ2H, : SHORT

MAIN PWB ASSY(Outdoor Unit)

• TOP VIEW

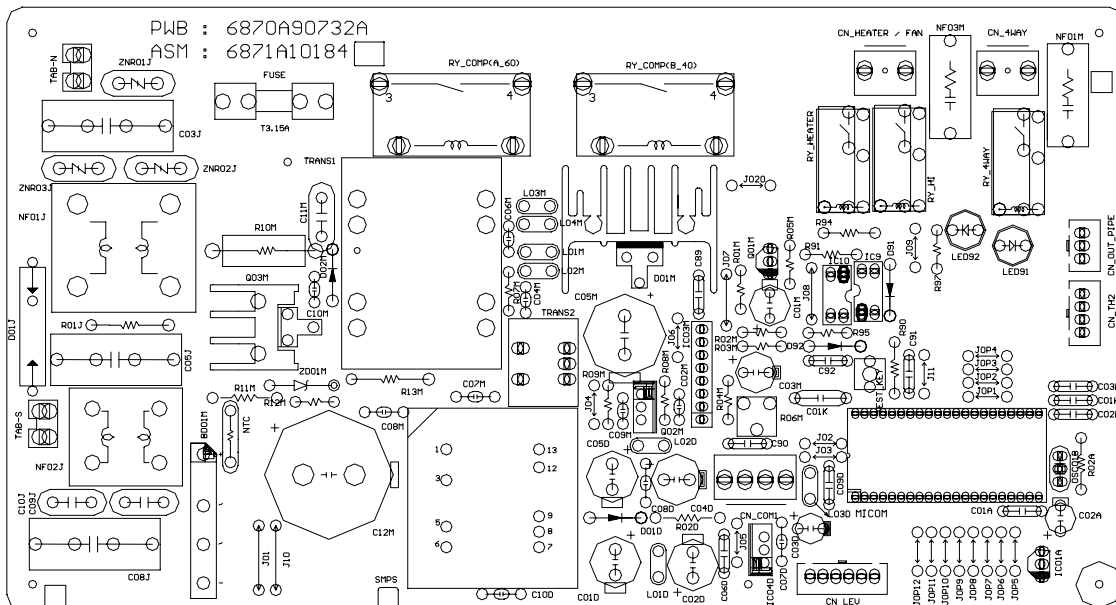

• BOTTOM VIEW

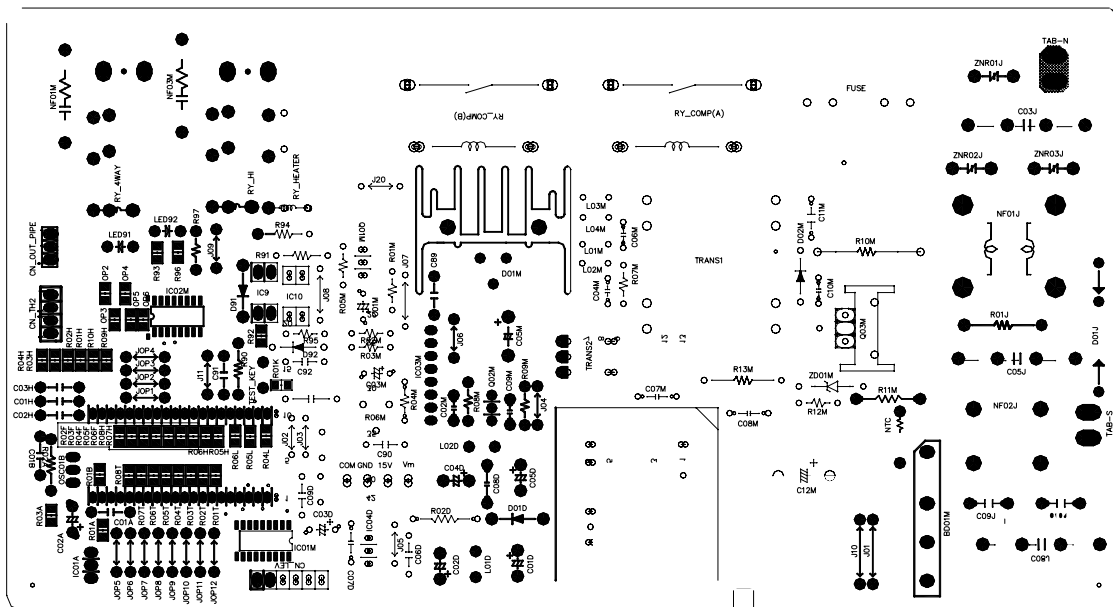

DISPLAY PWB ASSEMBLY

• TOP VIEW

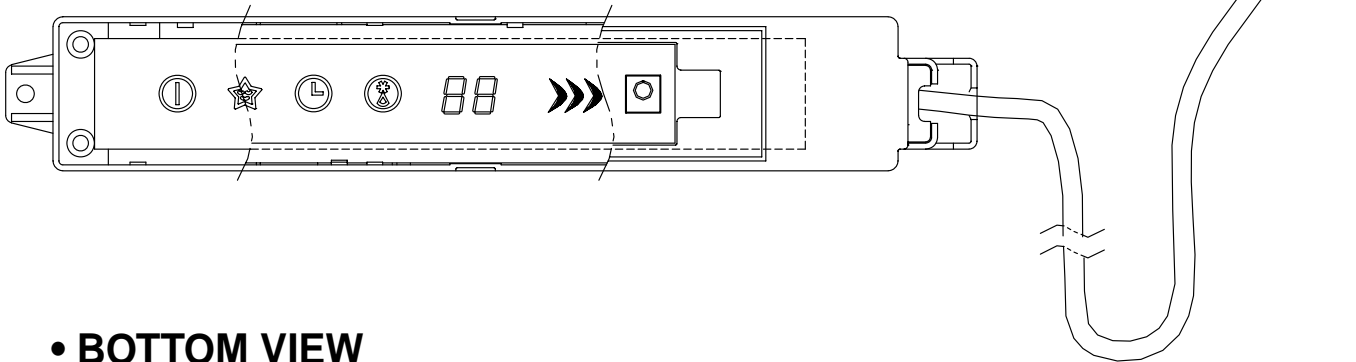
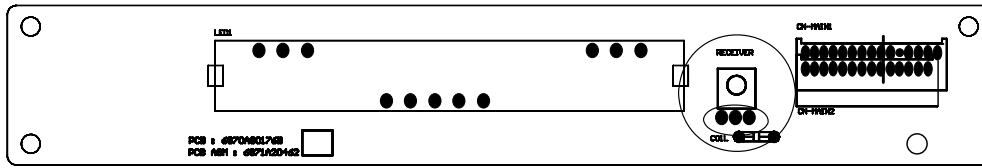

• BOTTOM VIEW

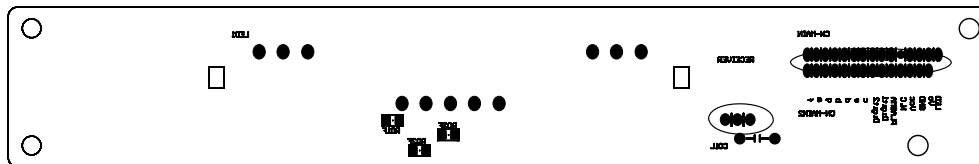

Schematic Diagram

Indoor Unit

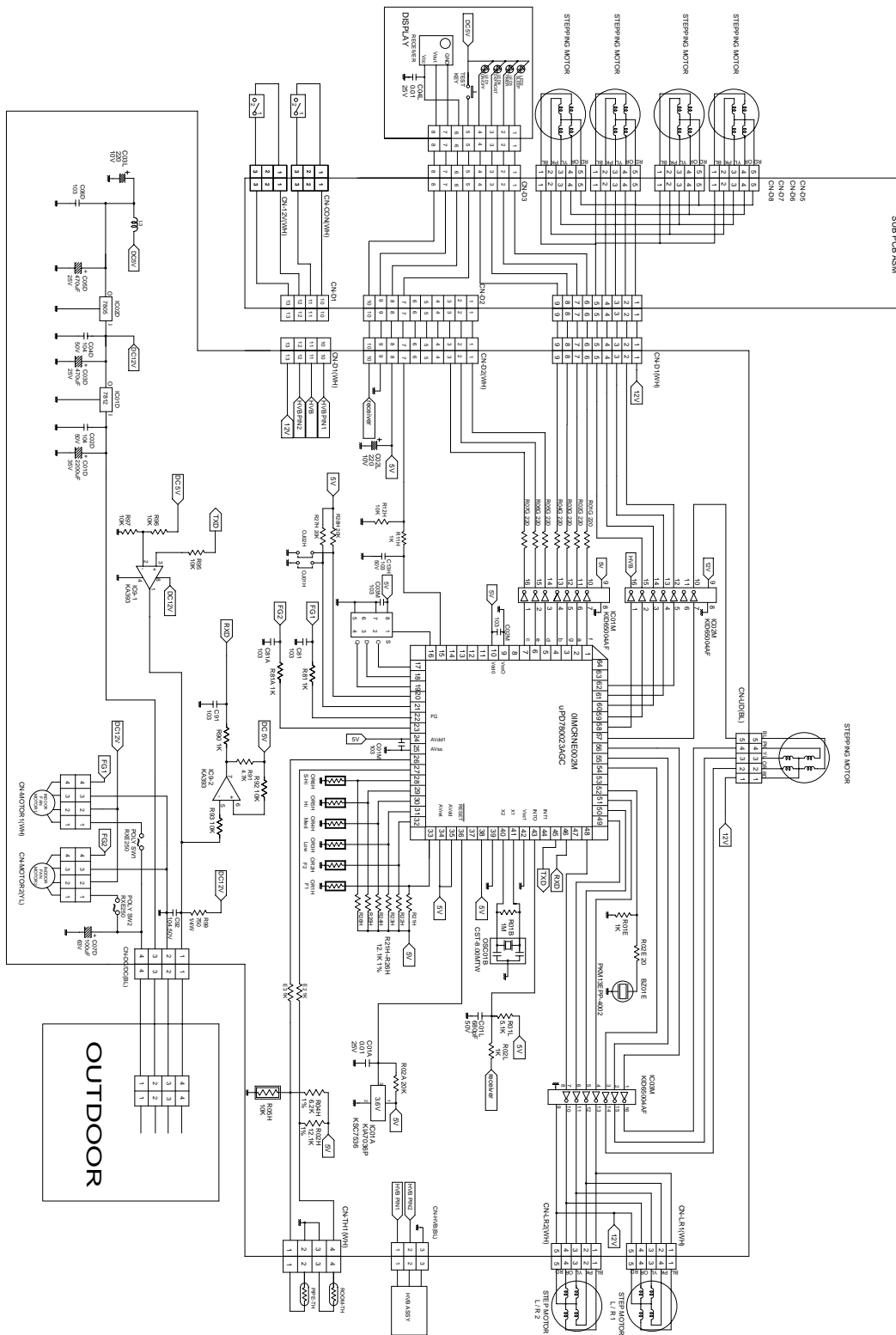

Outdoor Unit

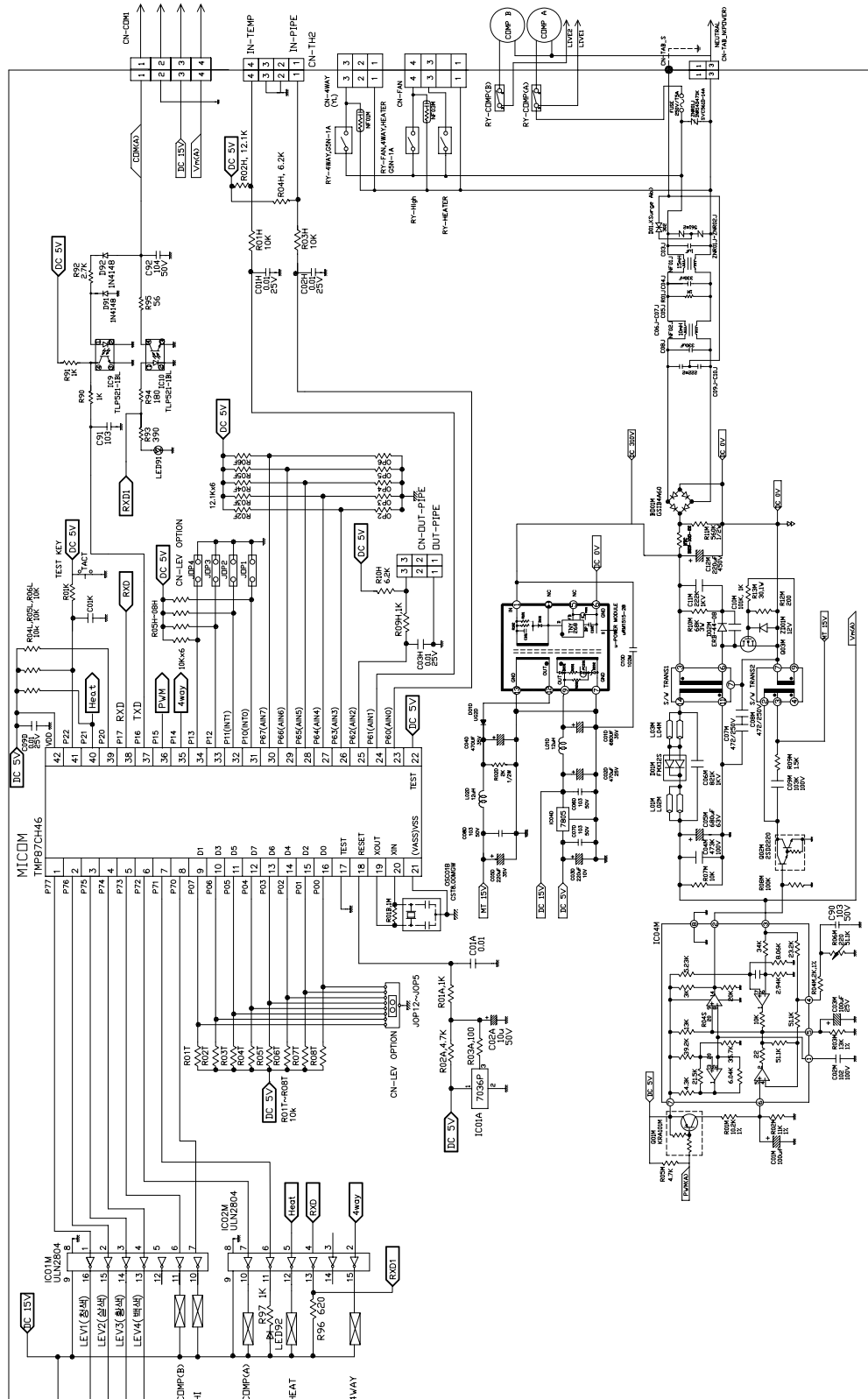

Exploded View and Replacement Parts List

Indoor Unit

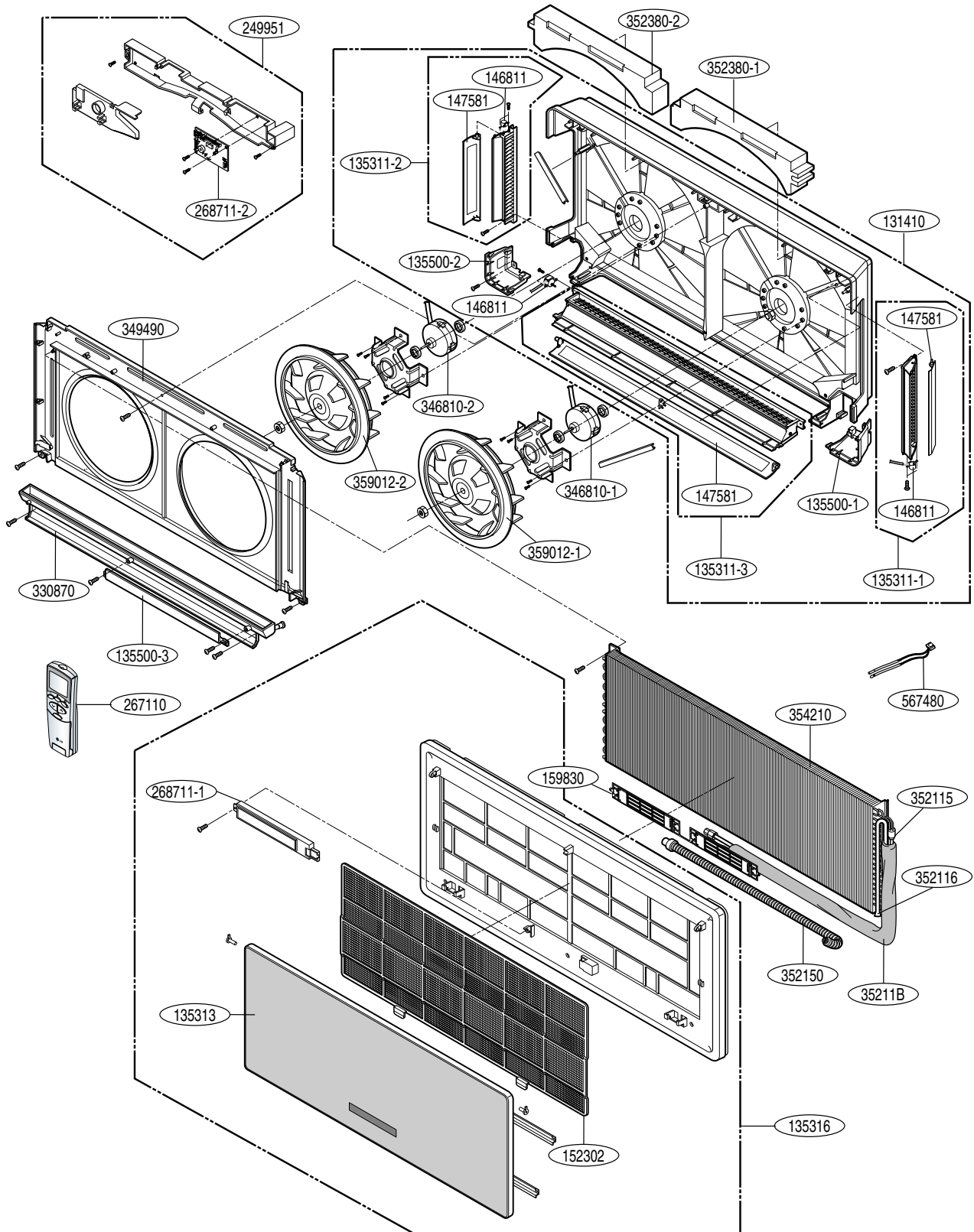

Parts List(indoor)

LOCATION No.	DESCRIPTION	PART No.	REMARKS
		LAN181CNW(ASNC183VML3) LA180CPF(ASNC183UML3)	
131410	CHASSIS ASSEMBLY	3141A20008J	R
135311-1	GRILLE ASSEMBLY,DISCHARGE(INDOOR)	3531A20124K	R
135311-2	GRILLE ASSEMBLY,DISCHARGE(INDOOR)	3531A20124J	R
135311-3	GRILLE ASSEMBLY,DISCHARGE(INDOOR)	3531A20125G	R
135316	GRILLE ASSEMBLY,FRONT(INDOOR)	3531A10334J	R
135500-1	COVER	3550A20512B	R
135500-2	COVER	3550A20120B	R
135500-3	COVER	3550A20121B	R
146811	MOTOR ASSEMBLY,STEP	4681A20055A	R
147581	LOUVER,HORIZONTAL	4758A20033A	R
147582	LOUVER,VERTICAL	4758A20034A	R
152302	FILTER(MECH),A/C	5230A10011A	R
159830	AIR CLEANER ASSEMBLY	5983A20006P	R
249951	CONTROL BOX ASSEMBLY,INDOOR	4995A20825A	R
263230	THERMISTOR ASSEMBLY	6323A20004N	R
267110	REMOTE CONTROLLER ASSEMBLY	6711A20083R	R
268712	PWB(PCB) ASSEMBLY,DISPLAY	6871A20462D	R
268714	PWB(PCB) ASSEMBLY,MAIN	6871A20387J	R
330870	DRAIN PAN ASSEMBLY	3087A20013B	R
346810-1	MOTOR ASSEMBLY,INDOOR	4681A20047C	R
346810-2	MOTOR ASSEMBLY,INDOOR	4681A20047D	R
349490	ORIFICE ASSEMBLY	4949A20002C	R
352115	TUBE ASSEMBLY,EVAPORATOR IN	5211A20302C	R
352116	TUBE ASSEMBLY,EVAPORATOR OUT	5211A20301F	R
35211B	TUBE ASSEMBLY,TUBING	5211A30038X	R
352150	HOSE ASSY,DRAIN	5251AR1222R	R
352380-1	AIR GUIDE	5238A10009A	R
352380-2	AIR GUIDE	5238A10010A	R
354210	EVAPORATOR ASSEMBLY,FIRST	5421A20104C	R
359012-1	FAN,TURBO	5900A00004A	R
359012-2	FAN,TURBO	5900A00005A	R
135313	GRILLE ASSEMBLY, INLET	3531A10270T	R

NOTE) *Please ensure GCSC since these parts may be changed depending upon the buyer's request.
(GCSC WEBSITE <http://biz.LGservice.com>)

2. Outdoor unit(18K)

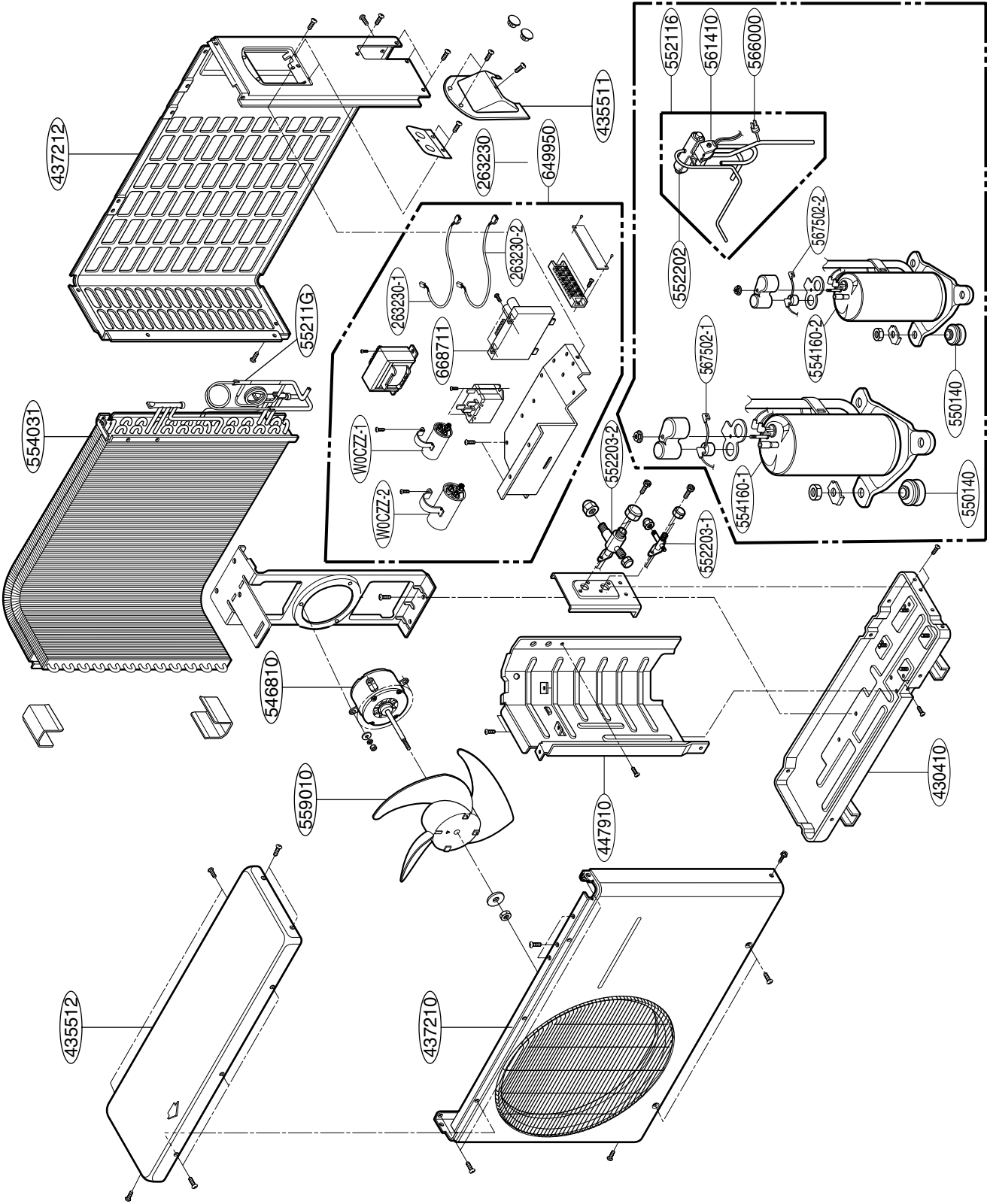

Parts List(outdoor)

LOCATION No.	DESCRIPTION	PART No.	REMARKS
		LAU181CNW(ASUC183VML3) LA180CPO(ASUC183VML3)	
552203-1	VALVE,SERVICE	2H02479B	R
552203-2	VALVE,SERVICE	5220A20006A	R
554031	CONDENSER ASSY,BENT	5403A20058B	R
554160-1	COMPRESSOR SET	2520UGJK2AA	R
554160-2	COMPRESSOR SET	2520UGAK2AA	R
559010	FAN ASSY, PROPOLLER	1A00195B	R
567502-1	O.L.P	6750U-L039A	R
567502-2	O.L.P	6750U-L058A	R
649950	CONTROL BOX ASSY, OUTDOOR	4995A20383W	R
668711	PWB(PCB) ASSY, MAIN(OUTDOOR)	6871A10184E	R
W0CZZ-1	CAPACITOR, DRAWING	3A00988B	R
W0CZZ-2	CAPACITOR, DRAWING	6120AR2194D	R
430410	BASE ASSY, OUTDOOR	3041AP2741G	R
435511	COVER ASSY, CONTROL(OUTDOOR)	3551AR7184T	R
437210	PANEL ASSY, FRONT (OUTDOOR)	3721A20005H	R
437212	PANEL ASSY, REAR (OUTDOOR)	3720AP0003D	R
550140-2	ISOLATOR, COMP	4H00637A	R
546810	MOTOR ASSY, OUTDOOR	4681A20013N	R
566000	SWITCH,PRESSURE	6600L000013	R
435512	COVER ASSY, TOP(OUTDOOR)	3H03266P	R
55211G	TUBE ASSEMBLY, CONDENSER OUT	5211A25034C	R
552200	VALVE, EXPANSION BODY	5220A90003B	R
561411	COIL ASSEMBLY, EXPANSION	6141A20032A	R
435301	GRILLE, DISCHARGE	3530A20007B	R
447910	BARRIER ASSEMBLY OUTDOOR	4791A30004K	R
263230-1	THERMISTOR ASSEMBLY	6323A20002L	R
263230-2	THERMISTOR ASSEMBLY	6323A20016A	R

NOTE) *Please ensure GCSC since these parts may be changed depending upon the buyer's request.
(GCSC WEBSITE <http://biz.LGservice.com>)



Free Manuals Download Website

<http://myh66.com>

<http://usermanuals.us>

<http://www.somanuals.com>

<http://www.4manuals.cc>

<http://www.manual-lib.com>

<http://www.404manual.com>

<http://www.luxmanual.com>

<http://aubethermostatmanual.com>

Golf course search by state

<http://golfingnear.com>

Email search by domain

<http://emailbydomain.com>

Auto manuals search

<http://auto.somanuals.com>

TV manuals search

<http://tv.somanuals.com>