

Ocean Electric Winches 34-77

Owner's Installation, Operation &
Basic Servicing Manual



LEWMAR®

www.lewmar.com

B2303 Issue 6. Ocean electric winches models 34-77.**For sizes over 77 please contact Lewmar for details.**

Introduction	4		
Product support	4		
Important information about this manual	4		
EMC Recommended guidelines	4		
CE Approvals	4		
Safety notices	4		
General	4		
Fitting	4		
Electrical	4		
1. Installation	5		
1.1 Identifying manual convertible winch	5		
1.2 Preparing manual winch for conversion	5		
1.3 Fitting a complete electric winch from new	5		
1.4 Positioning winch above deck	5		
1.5 Positioning winch ancillaries below deck	6		
1.6 Fitting a convertible electric winch 34-65	6		
1.7 Fitting a convertible electric winch 66-77	8		
1.8 Fastenings	8		
1.9 Winch motor gearbox couplings	8		
2. Electrical wiring installation	9		
2.1 Typical electrical layout	9		
2.2 Correct main spindle rotation	9		
3. Electrical connections	10		
3.1 E Series Electric 34-48	10		
3.2 ELS Electric Load Sensing 34-48	10		
3.3 ELS Electric Load Sensing 50-65	11		
3.4 ELS Electric Load Sensing 2/3 speed 66-77	11		
3.5 EVC Electric Variable Control 34-48	12		
3.6 EVC Electric Variable Control 50-65	12		
3.7 NEW Electric deck switch	13		
		4. Performance diagrams	13
		5. Safe working loads	14
		5.1 Optimum rope diameters	14
		5.2 Maximum winch load values	14
		6. Operating your winch	14
		7. Servicing your winch	15
		8. Parts list	16
		8.1 Winch notes	16
		8.2 Models 34-65	16
		8.3 Models 66-77	17
		9. Dimensions	18
		10. Total weight	19
		11. Electric convertible model range	19
		11.1 Winches 34-77	19/20
		11.2 Circuit breakers	20
		11.3 NEW Electric deck switch	20
		12. Fault finding	21
		13. Lewmar limited warranty	22

Introduction

Dear Customer,

Thank you for choosing Lewmar Electric Ocean Winches. Lewmar products are world renowned for their quality, technical innovation and proven performance. With a Lewmar winch you will be provided with many years of outstanding service. We wish you happy sailing.

Product support

Lewmar products are supported by a worldwide network of distributors and Authorised Service Representatives. If you encounter any difficulties with this product, please contact your national distributor, or your local Lewmar dealer. Details are available at:

www.lewmar.com

Important information about this manual

Throughout this manual, you will see safety and product damage warnings. You must follow these warnings carefully to avoid possible injury or damage.

The type of warnings, what they look like, and how they are used in this manual are explained as follows:



Warning!

This is a warning against anything which may cause injury to people if the warning is ignored. You are informed about what you must or must not do in order to reduce the risk of injury to yourself and others.



Safety Symbol

When you see the safety symbol it means: "Do not..."; "Do not do this"; or "Do not let this happen".

CE Approvals

For CE approval certificates contact Lewmar.



This manual forms part of the product and **MUST BE RETAINED** along with, OR incorporated into, the Owner's Manual for the vessel to which the winch is fitted.

Safety notices

General

Please ensure that you thoroughly understand the operation and safety requirements of the winch before commencing the installation. Only persons who are completely familiar with the controls and those who have been fully made aware of the correct use of the winch should be allowed to use it. If there is any doubt of how to install or operate this unit please seek advice from a suitably qualified engineer.

- Winches used incorrectly could cause harm to equipment or crew.
- Winches should be used with care and treated with respect.
- Sailing, like many other sports can be hazardous. Even the correct selection, maintenance and use of proper equipment cannot eliminate the potential for danger, serious injury or death.
- Lewmar winches are designed and supplied for line control in marine applications and are to be used in conjunction with appropriate clutches, cleats and other manual controls and stoppers.
- It is the unavoidable responsibility of the owner or master or other responsible party to assess the risk of any operation on the vessel.
- Under no circumstances should any self tailing winch be used in self tailing mode for any lifting operation; rather suitable and adequate manual tailing should be arranged with proper means of manually cleating or stopping the hoist.
- Every winch should be installed with adequate means of manually cleating or stopping the loaded ropes.
- Lewmar recommends the use of appropriate Personal Protective Equipment and hands free communication equipment by any person going aloft, and only then where the person going aloft is properly trained in the use of that equipment and where there remain sufficient trained and experienced personnel on deck to ensure constant observation and the continued safe conduct both of the vessel and the hoisting operation.

Fitting

- This equipment must be installed and operated in accordance with the instructions contained in this manual. Failure to do so could result in poor product performance, personal injury and/or damage to your boat.
- Consult the boat manufacturer if you have any doubt about the strength or suitability of the mounting location.

Electrical

- Make sure you have switched off the power before you start installing this product.
- If in doubt about installing electrical equipment please seek advice from a suitably qualified electrical engineer.

To the best of our knowledge, the information in this manual was correct when it went to press. However, Lewmar cannot accept liability for any inaccuracies or omissions it may contain. In addition, our policy of continuous product improvement may change specifications without notice. As a result, Lewmar cannot accept liability for any differences between the product and the manual.

1. Installation

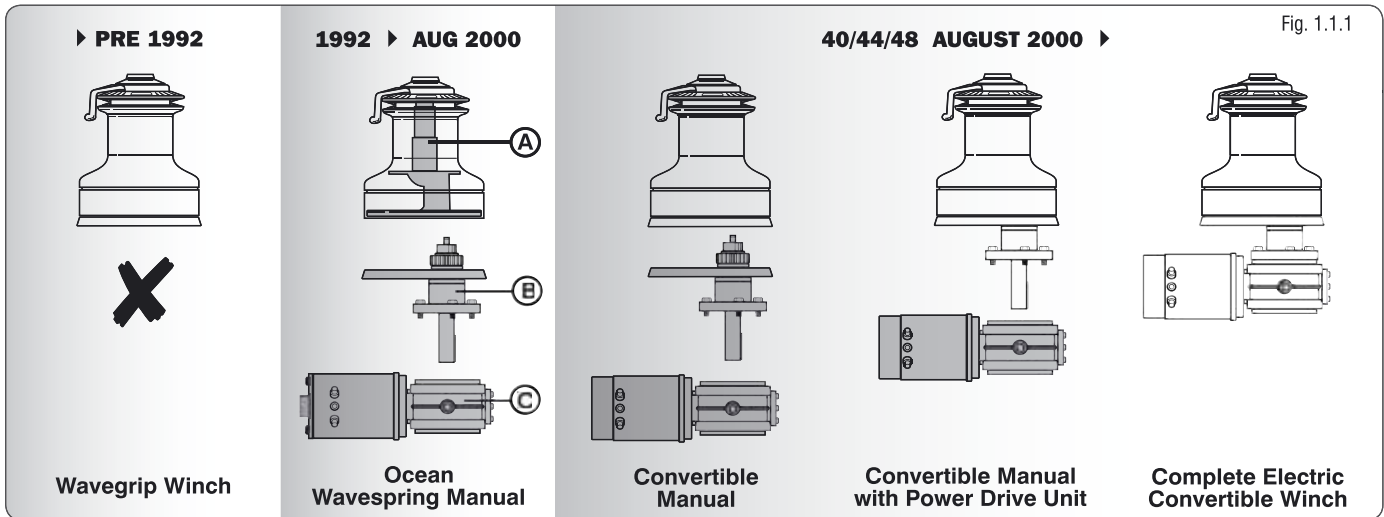

1.1 Identifying the manual convertible winch

• Fig. 1.1.1

Pre Ocean winches, i.e. fixed jaw Wave Grip winches, made before 1992 are NOT convertible.

Convertible manual winches made in August 2000 will be date marked H/00 on the centre stem, (H = August; 00 = year 2000). They also carry a blue sticker on the screw-on top-cap showing a winch handle and a hand operating an electric deck switch. These winches can be converted by adding the Power Drive Base (B) unit and the required Motor Gearbox (C), Control Box and Switch-gear (12 V or 24 V).

- Ocean Wave Spring manual winches made between 1992 and August 2000 are NOT fitted with the necessary centre stem to convert to powered operation. A Centre Stem Kit (A) is available to convert the early Ocean Wave Spring winches from (1992 to July 2000). The part numbers are listed below. Pre Ocean Winches, i.e. fixed jaw Wave Grip winches, made before 1992 are NOT convertible.

Winch Model	Description	Part Number
40	Centre Stem Kit	48040037
44	Centre Stem Kit	48044037
48	Centre Stem Kit	48048037

1.2 Preparing the manual winch for conversion to electric

- Remove the winch from the deck (if already installed) and remove the Centre Plate, which is located on the underside of the Centre Stem, by using a soft hammer and punch (Fig. 1.2.1).
- Remove any sharp edges and clean, to remove all old bedding/sealing compounds from the underside of the Centre Stem.

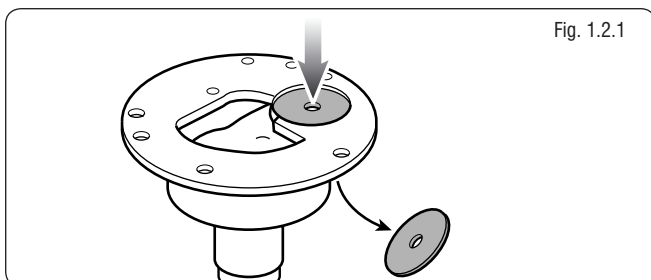

1.3 Fitting a complete electric winch from new

- Test fit the winch to the Power Drive Base and Gearbox to check the orientation and the necessary clearance needed BEFORE DRILLING ANY HOLES.
- Now follow sections 1.4 and 1.5.

1.4 Positioning winch above deck

- Lewmar recommend that the rope enters onto the drum at an angle of -5° to -10° to the base axis of the winch. To achieve this angle it may be necessary to use a base wedge when installing the winch (Fig. 1.4.1). The winch must be mounted on an even surface.

⚠ Always keep in mind the space available below the deck for the motor gearbox.

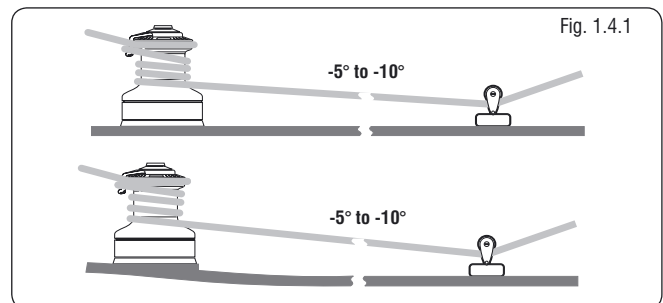

- If practical, for best performance, the winch should be installed so that the output gear is situated in the optimum position in relation to the load (Fig. 1.4.2).

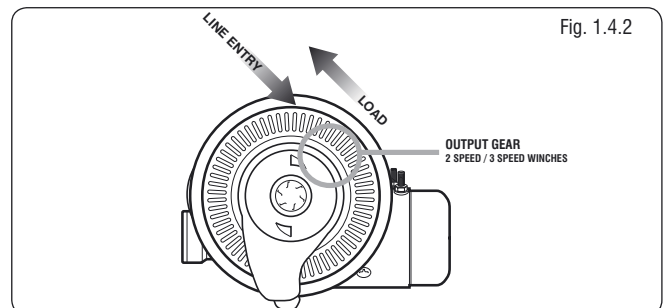

- Use the template provided as a guide to position the winch on the deck.

NOTE: Check the scale of the template matches the winch (Fig 1.4.3).

NOTE: Make sure there is room below deck for motor and sub box.

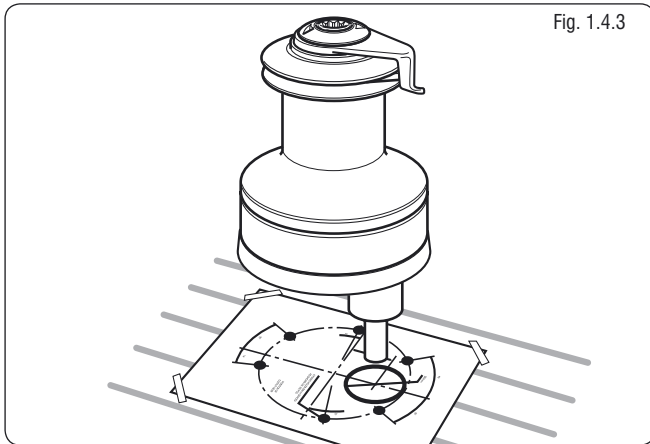

Fig. 1.4.3

1.5 Positioning winch ancillaries below deck

NOTE: The positioning of the motor gearbox must be checked prior to cutting for deck/hull and bulkhead clearance.

- The motor gearbox can be rotated in 90° steps, Fig. 1.5.1.

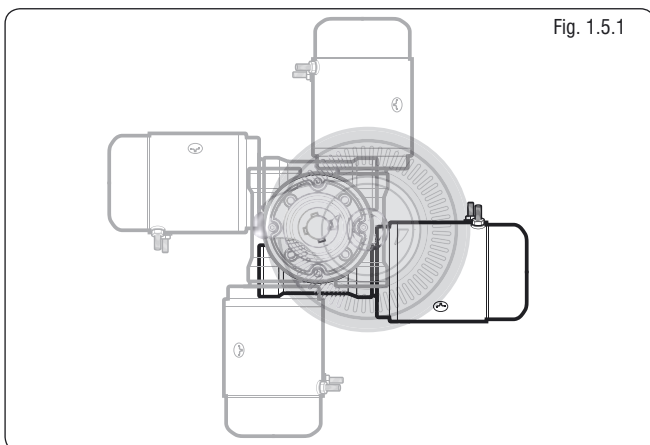

Fig. 1.5.1

- The motor rotation is factory set for fitting as Fig. 1.5.2.

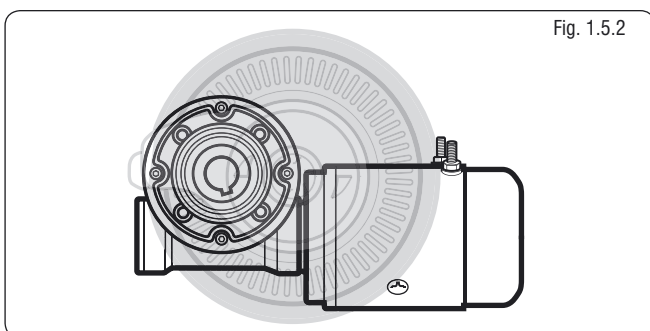

Fig. 1.5.2

NOTE: The motor can be fitted as Fig. 1.5.3.

- Contact Lewmar for correct fitting of electrical connections. If the motor is unintentionally fitted this way on a single speed winch it will not operate and make a clicking noise, on a 2 or 3 speed winch it will dramatically reduce performance.

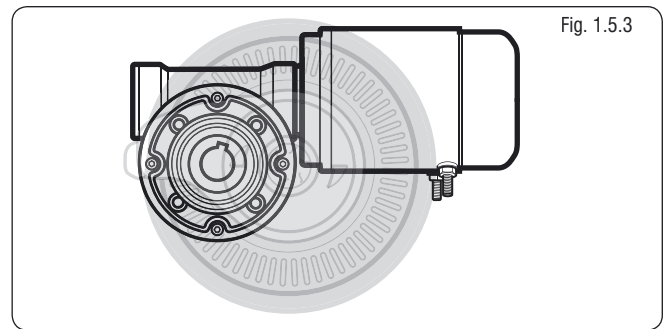

Fig. 1.5.3

- Check clearance below deck and accessibility then position the deck switches near and in view of the winch. Use the templates provided as a guide to cut/drill hole, fit switch and seal.

NOTE: Air switch tubing must be twist and chafe free to the switch unit (sub box).

⊘ DO NOT cover the air bleed hole with sealant as this will stop air escaping and could result in winches self operating as the air expands with rising temperatures in the tube.

⚠ Once you have selected the position for the winch, motor gearbox and controls, double check everything and only then drill the holes in the deck.

1.6 Fitting a convertible electric winch 34-65

NOTE: Illustrations are based on a model 50 winch.

- Place the winch in position to ensure correct fit once the holes have been drilled/cut (Fig. 1.6.1).

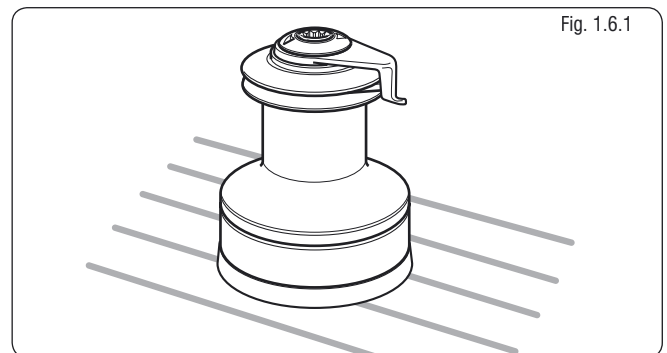

Fig. 1.6.1

- Unscrew the top cap (Fig. 1.6.2).

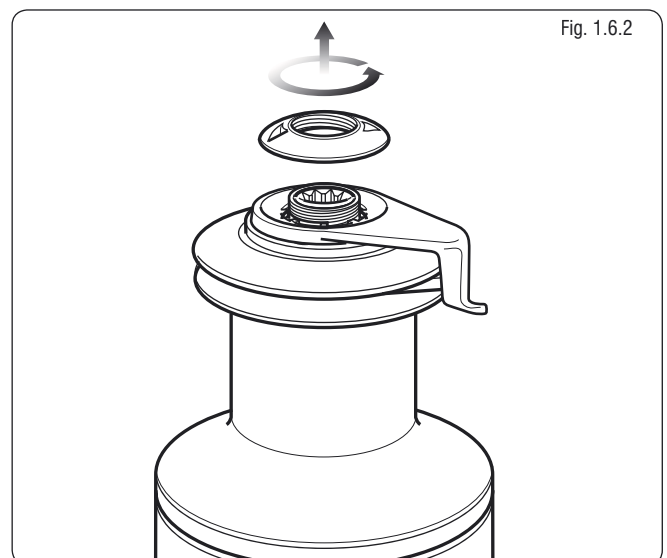
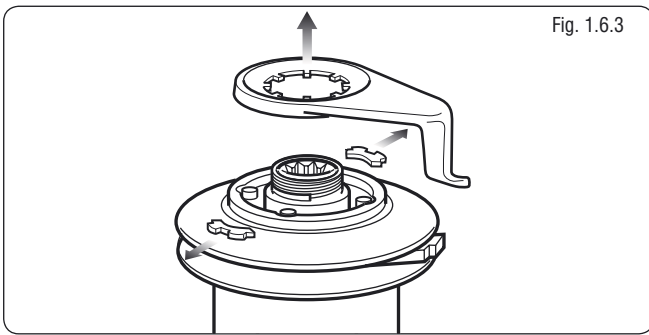
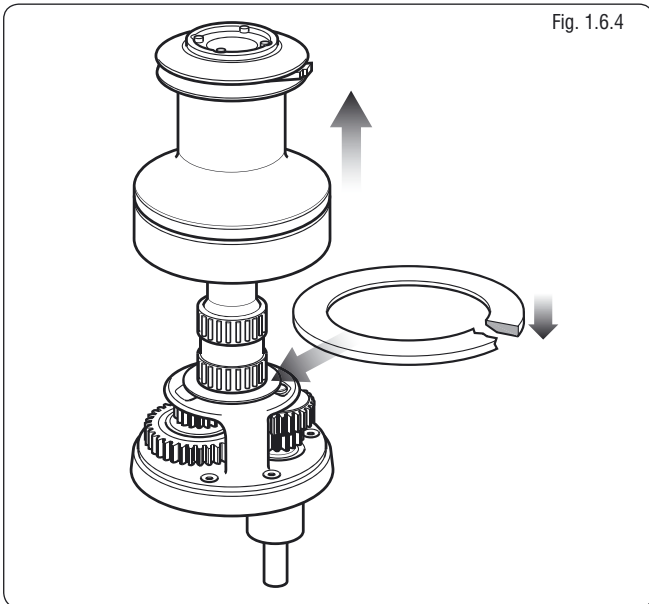

Fig. 1.6.2

- Remove feeder arm and collets (Fig. 1.6.3).



- Lift drum off (Fig. 1.6.4). Take care in re-fitting the drum washer with bevel on underside.



- Remove all screws holding centre stem to base (Fig. 1.6.5). Using a flat bladed screwdriver in the drainage slots, lever off centre stem assembly clear of the two dowel pins.

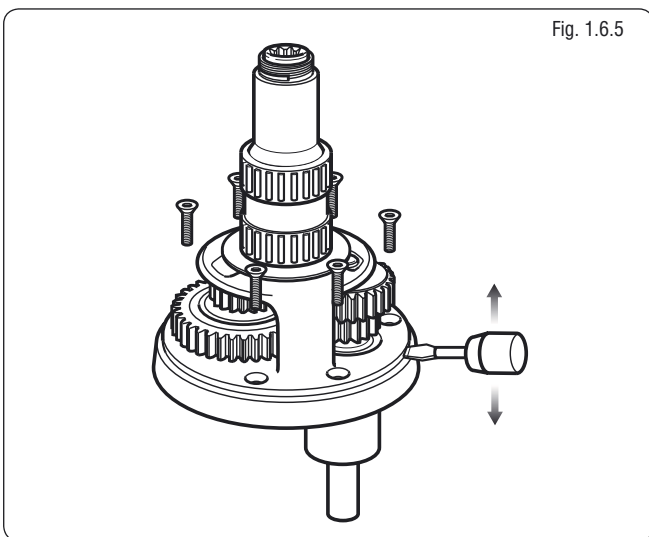

- Take care to hold the gear stack in position as shown (Fig. 1.6.6). (If pawl gear falls away... note shoulder face is down). Take care that pawls and pawl springs are kept in place, while rebuilding/placing the centre stem onto the base.

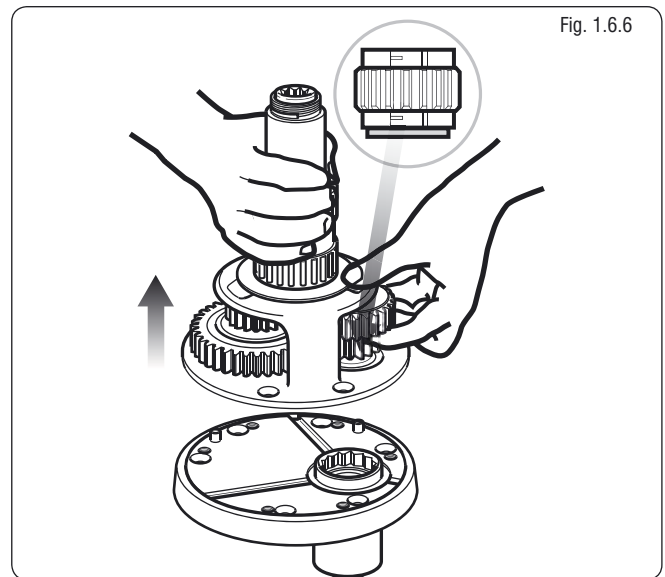

- Remove the base plate cover. Lift the base and bed down with a light coating of sealing compound to prevent leaks (Fig 1.6.7).

NOTE: Do not use excessive sealant.

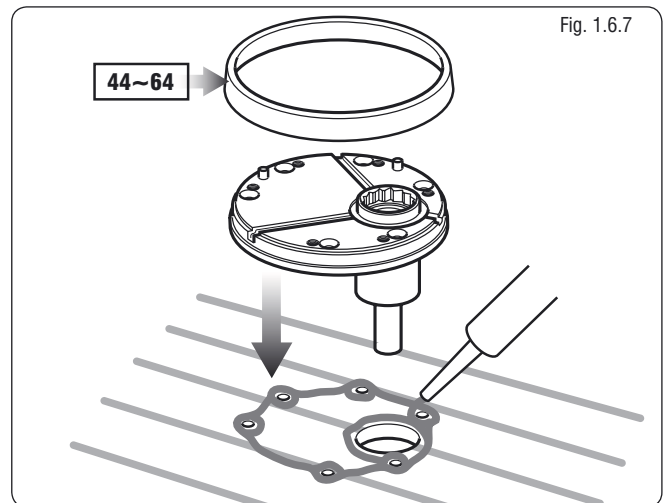

- Consult the fastening guide in section 1.8 for bolt type and length. Bolt the base plate to the deck ensuring that all fastening heads are countersunk and correctly and replace base plate cover (Fig 1.6.8).

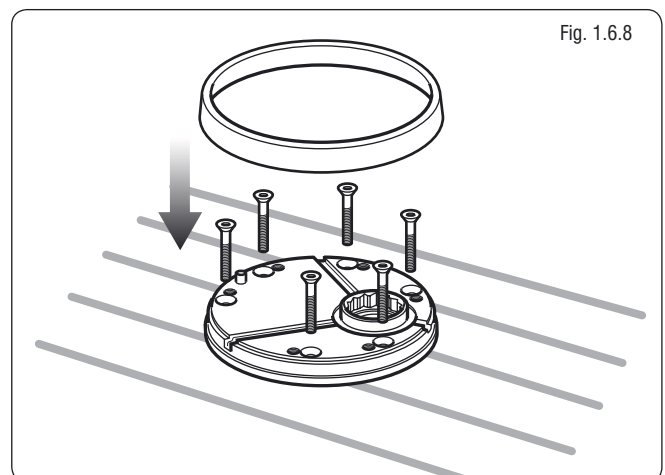

- Refit the centre stem assembly, taking care to hold the gear stack in position as before (Fig 1.6.9). Rotating the gears will facilitate re-engagement of the pawls, and ratchet tracks.

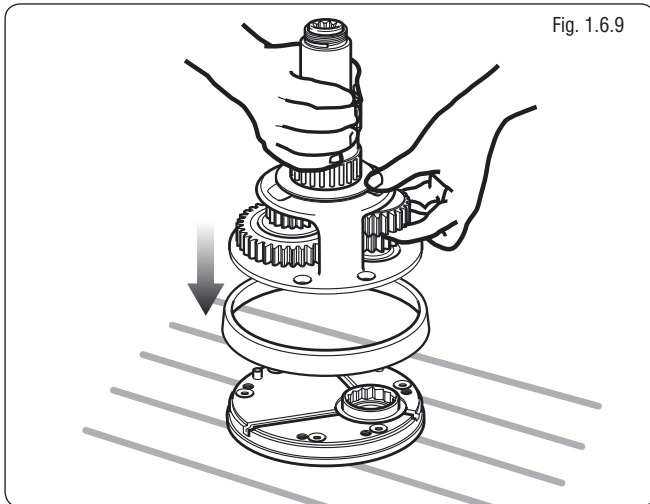

- Replace the drum, collets, feeder arm in correct feeder position and screw on the top cap.

1.7 Fitting a convertible electric winch 66-77

For winches 66-77, simply remove the winch drum and access to mounting holes is available through holes in the base of the centre stem.

1.8 Fastenings

Fix the winch to the deck using CSK Head, Stainless Steel Washers/Locknuts.

- For the correct bolt length refer to Fig. 1.8.1 and table.

NOTE: Deck fastenings are not supplied.

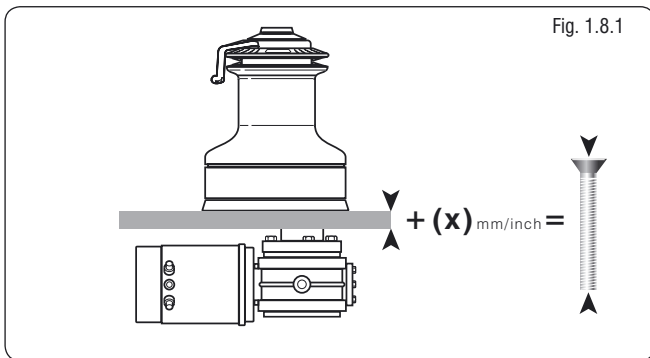

Winch	Fastening	X mm (min.)	X inch (min.)
34/40	5 x M6 (1/4" W)	30	1 1/4
44/48	5 x M8 (5/16" W)	33	1 5/16
50/54	6 x M8 (5/16" W)	33	1 5/16
58	5 x M10 (3/8" W)	36	1 7/16
64/65	5 x M10 (3/8" W)	38	1 1/2
66/68 & 77	6 x M10 (3/8" W)	31	1 1/4

1.9 Winch/motor gearbox coupling

Mechanical coupling of the horizontal drive unit and reduction gearbox to the winch should be mounted as Fig 1.9.1 (34-65) and Fig. 1.9.2 (66-77) with instructions of previous pages.

- The horizontal drive unit assembly should be bolted from below decks. Use threadlock on item No.15 (see Sec. 8.2).
- If a thick deck or increased motor/gearbox distance from deck demands a greater 'T' dimension (see Sec. 9). Optional extension kits are available to special order. Contact your nearest Lewmar office.

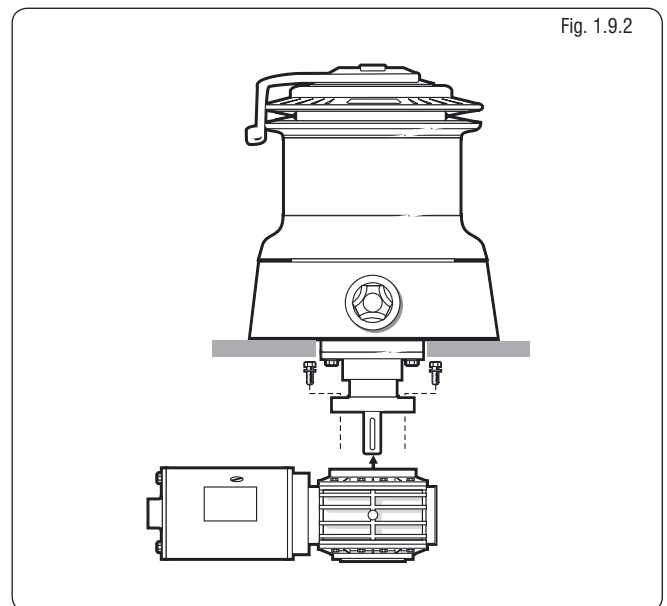
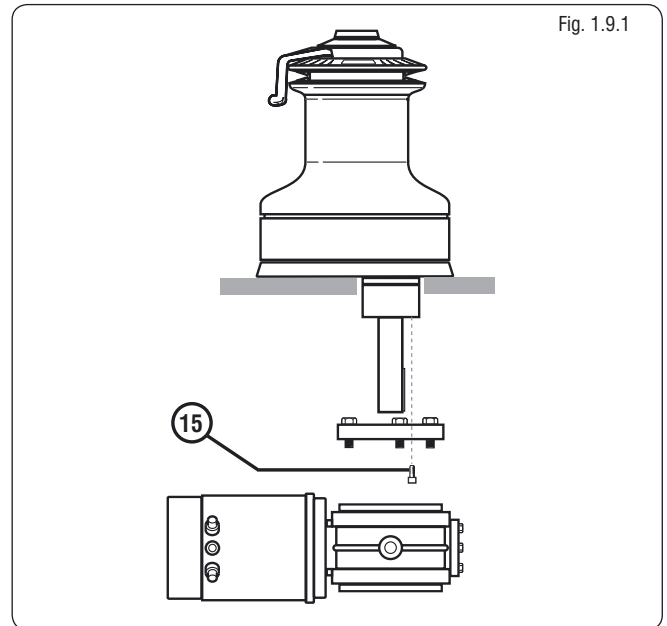

2. Electrical wiring installation

Fig. 2.1.1

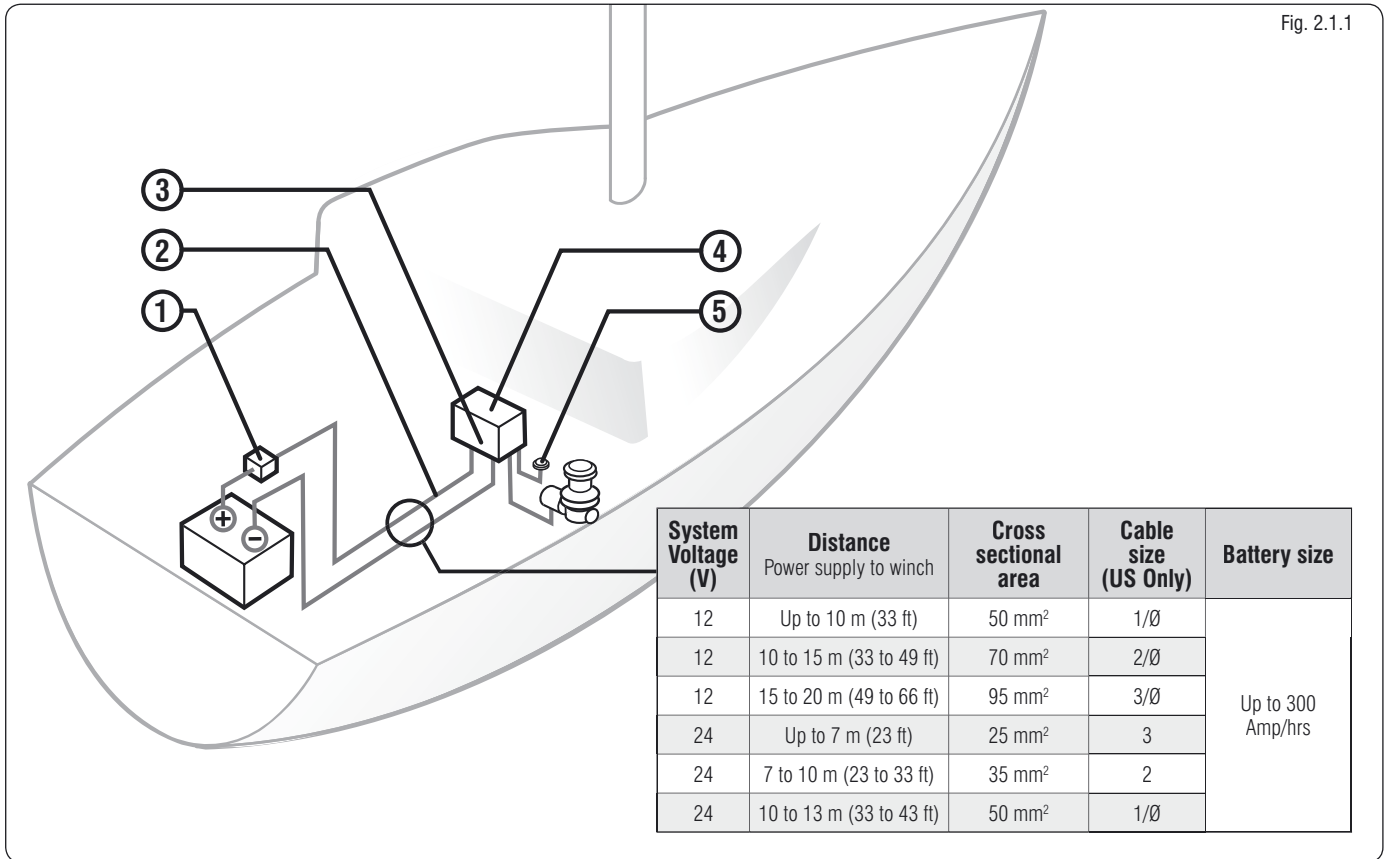

2.1 Typical electrical layout

NOTE: This is not a wiring diagram.

1. Position the recommended circuit breaker close to the battery. See wiring diagrams Sec. 3.
2. Route 2 cables (see size table above) from battery to the control box.
3. Attach motor cables to control box (see wiring diagram) using recommended cable sizes.
4. Position the control box near the winch (± 1 metre) in a dry area for watertight security and accessible for maintenance.
5. Position deck switches in view of winch. Route wire and attach to control box (see wiring diagram).

2.2 Main spindle rotation

- Check correct main spindle rotation when fitted and operated.

Fig. 2.2.1

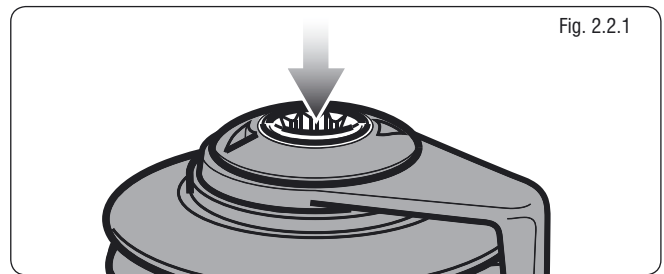

Winch	1st Gear	2nd Gear	3rd Gear
2 Speed 66-77	↻	↻	
3 Speed 66-77	↻	↻	↻

3. Electrical connections

3.1 E Series Electric 34-48, 12V or 24V

- This simple installation of a power drive unit, motor and switch gear controls the winch by a single direction contactor, which can be a Contactor housed in a waterproof box (Fig 3.1.1), or a stand alone Nylon encased unit (Fig 3.1.2).
- The motor thermal trip is connected to monitor motor temperature while the Lewmar safety electric deck switch can be easily wired.
- Manual override facility is still available for backup, or as a means of experiencing traditional sailing.
- Two plus one speed comes as standard control which gives two speed manual drive (handle) plus one speed electric drive.

Fig. 3.1.1 Single direction contactor in box with thermal cutout. 12 V (18000301) or 24 V (18000302). Also see Section 3.7.

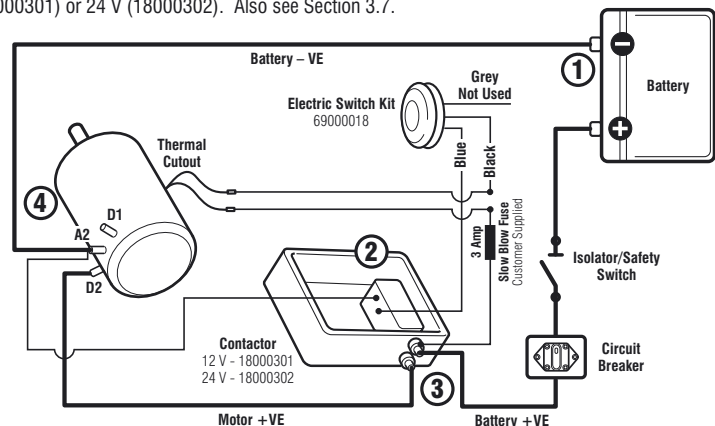
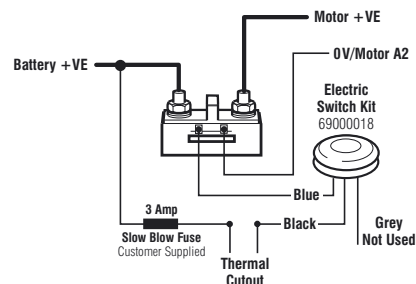

Fig. 3.1.2 Contactor 12 V (0052505) or 24 V (0052506)



3.2 ELS Electric Load Sensing 34-48, 12 V or 24 V

- This installation controls the winch by Lewmar's unique Overload Protection Control Box (Fig 3.2.1), this allows the winch to be operated up to the Safe Working Load for winch size.
- Other features as Section 3.1

⊘ Total voltage drop **MUST NOT** exceed 5% of supply over completed cabling installation. Check all connections for water tight security. Lewmar recommends an isolator to be fitted in the circuit in an accessible position as close as possible to the supply.

⚠ Connect the power supply cables to the battery last when the winch installation has been completed and checked for correct installation. Incorrect connection of motor cables may damage the unit.

Fig. 3.2.1 12 V or 24 V Control box with overload protection. Also see Section 3.7.

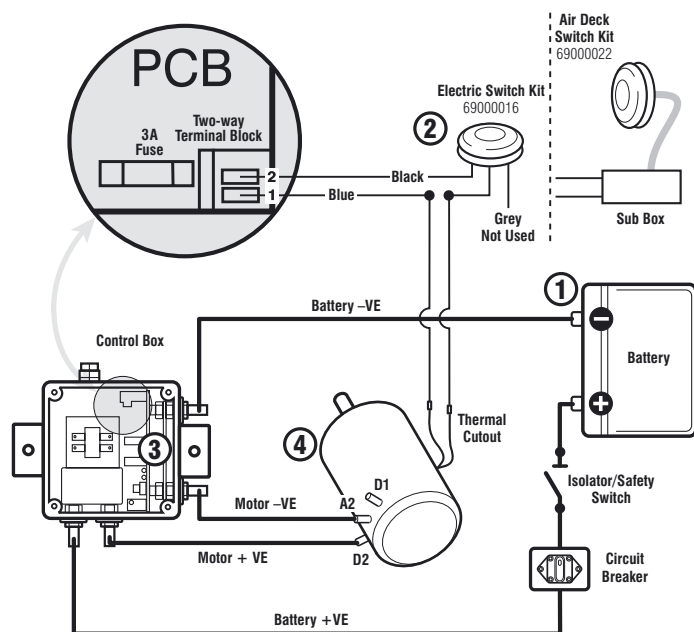

NUMBER KEY FOR ALL ELECTRICAL DIAGRAMS

- ⊘ ① Negative earth **MUST** be used.
- ② The deck switch wires **MUST** be fitted as shown on wiring diagrams.
- ⚠ ③ Connect all low power wiring (deck switches, motor cutout etc.) before fitting high power cables to controller.
- ④ Cable boots are supplied for all high power cable connections, follow guidelines Fig. 2.1.1 for cable sizing.

3.3 ELS Electric Load Sensing 50-65, 12 V or 24 V

- This installation controls the winch by Lewmar's unique Overload Protection Control Box (Fig 3.3.1), this allows the winch to be operated up to the Safe Working Load for winch size.
- Other features as Section 3.1

⚠ Total voltage drop **MUST NOT** exceed 5% of supply over completed cabling installation. Check all connections for water tight security. Lewmar recommends an isolator to be fitted in the circuit in an accessible position as close as possible to the supply.

⚠ Connect the power supply cables to the battery last when the winch installation has been completed and checked for correct installation. Incorrect connection of motor cables may damage the unit.

Fig. 3.3.1 12 V or 24 V Control box with overload protection. Also see Section 3.7.

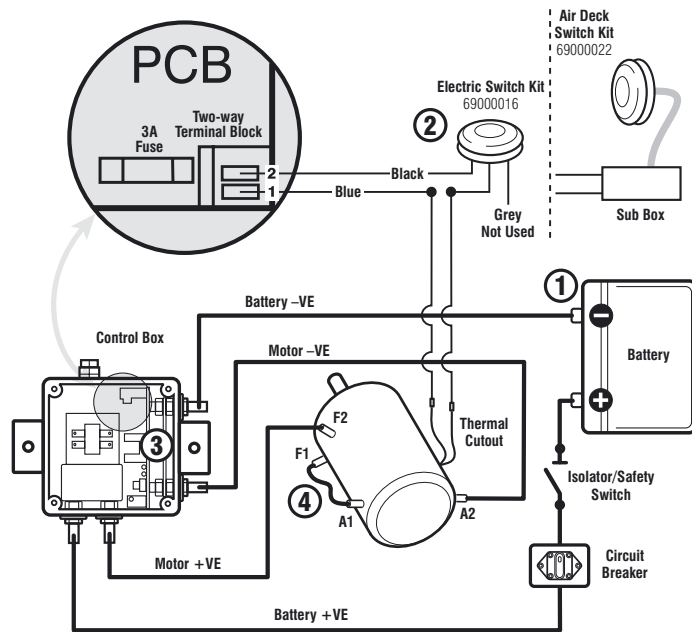

Fig. 3.4.1a 2 Speed winch electrical connections

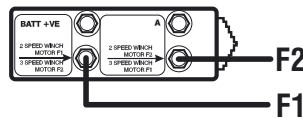
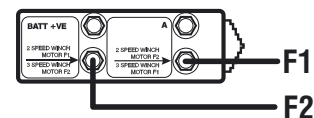

Fig. 3.4.1b 3 Speed winch electrical connections



3.4 ELS Electric Load Sensing 2/3 speed controller 66/68-77, 12 V or 24 V

- This installation controls the winch by Lewmar's unique Overload Protection & Autoshift Control Box (Fig. 3.4.1). This allows the winch to be started in 1st and if reaches the Safe Working Load, for the winch size and gear, will automatically shift the winch into 2nd gear for complete load control. In the case of a 3 speed winch (Fig. 3.4.1b) the switch must be re-selected to achieve 3rd gear.

⚠ Total voltage drop **MUST NOT** exceed 5% of supply over completed cabling installation. Check all connections for water tight security. Lewmar recommends an isolator to be fitted in the circuit in an accessible position as close as possible to the supply.

⚠ Connect the power supply cables to the battery last when the winch installation has been completed and checked for correct installation. Incorrect connection of motor cables may damage the unit.

Fig. 3.4.1 2/3 Speed 12 V or 24 V control box with overload protection. Also see Section 3.7.

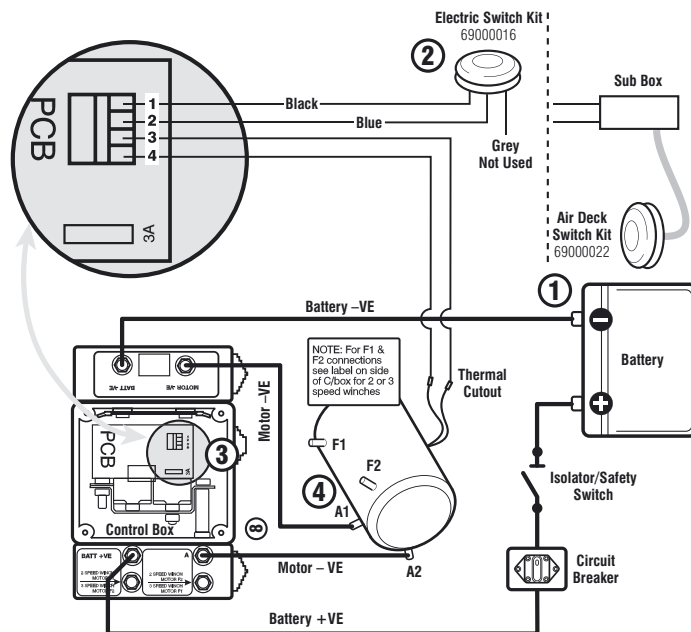

NUMBER KEY FOR ALL ELECTRICAL DIAGRAMS

- ⚠ ① Negative earth **MUST** be used.
- ⚠ ② The deck switch wires **MUST** be fitted as shown on wiring diagrams.
- ⚠ ③ Connect all low power wiring (deck switches, motor cutout etc.) before fitting high power cables to controller.
- ⚠ ④ Cable boots are supplied for all high power cable connections, follow guidelines Fig. 2.1.1 for cable sizing.

3.5 EVC Electric Variable Control. Standard controller single speed winches 34-48, 12 V & 24 V

- The EVC winch controller is a variable speed motor controller which can drive the winch in 3 different ways:
 - SW 1 drives the winch at full speed.
 - SW 2 drives the winch at a set speed determined by adjustable dial marked (SP) on the control box. On supply the dial is preset by Lewmar to drive the winch at 60% of full speed.
 - If optional Vario Control is fitted then the winch will drive at a speed determined by adjustment of the Vario Control when deck switch (SW 2) is engaged.
- The EVC controller uses current sensing to halt the operation of the winch when the winch has reached its Maximum Safe Working Load.
- The EVC controller features a Ramp/Soft Start to control the winch start up, adjustment of dial RA will vary the start period between 0.5 - 5 seconds. The dial is preset by Lewmar for a start period of 1 second.
- In order to adjust the speed (SP) and Ramp (RA) dials, unscrew the plug screws, on top of the controller 4 full turns and retract the plug/screw assembly. Use an electrical slotted (2.5mm Max.) screwdriver to adjust the internal dial to the desired setting.

3.6 EVC Electric Variable Control. Standard & high power controller single speed winches 50-65, 12 V & 24 V

- The EVC winch controller is a variable speed motor controller which can drive the winch in 3 different ways:

NOTE: Standard EVC used on 50-65 24 V. High power EVC used on 50-65 12 V.

 - SW 1 drives the winch at full speed.
 - SW 2 drives the winch at a set speed determined by adjustable dial marked (SP) on the control box. On supply the dial is preset by Lewmar to drive the winch at 60% of full speed.
 - If optional Vario Control is fitted then the winch will drive at a speed determined by adjustment of the Vario Control when deck switch (SW 2) is engaged.
- The EVC controller uses current sensing to halt the operation of the winch when the winch has reached its Maximum Safe Working Load.

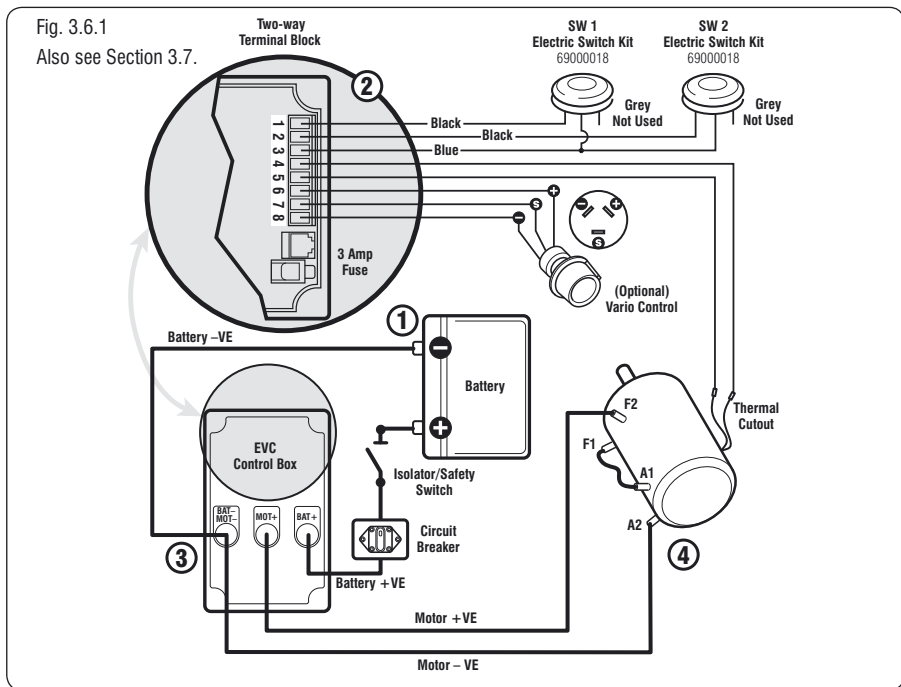
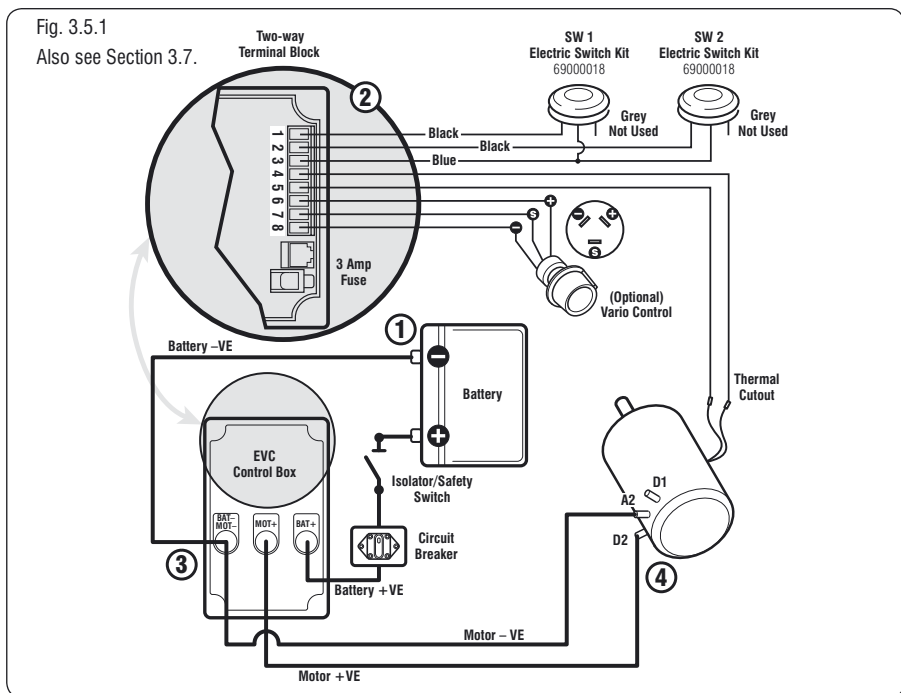

- The EVC controller features a Ramp/Soft Start to control the winch start up, adjustment of dial RA will vary the start period between 0.5 - 5 seconds. The dial is preset by Lewmar for a start period of 1 second.
- In order to adjust the speed (SP) and Ramp (RA) dials, unscrew the plug screws, on top of the controller 4 full turns and retract the plug/screw assembly. Use an electrical slotted (2.5mm Max.) screwdriver to adjust the internal dial to the desired setting.

NUMBER KEY FOR ALL ELECTRICAL DIAGRAMS

- ⓪ Negative earth MUST be used.
- Ⓛ The deck switch wires MUST be fitted as shown on wiring diagrams.
- ⚠ Connect all low power wiring (deck switches, motor cutout etc.) before fitting high power cables to controller.
- Ⓛ Cable boots are supplied for all high power cable connections, follow guidelines Fig. 2.1.1 for cable sizing.

3.7 NEW Electric deck switch

- The new electric deck switch can be ordered unlit (69000018) or lit (69000350/48000170).

NOTE: In lit option the wires should be connected separate to the electric winch control box, to avoid any possibility of a signal upsetting/interfering with the control box circuit. Use a general lighting circuit and fused at the ship's main circuit panel.

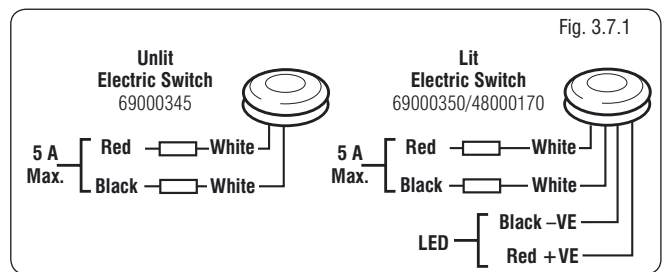

4. Performance diagrams

The following graphs show line speed and amperage draw relative to the load applied. Each control box is set to cut out at the SWL which is 50% of the breaking load.

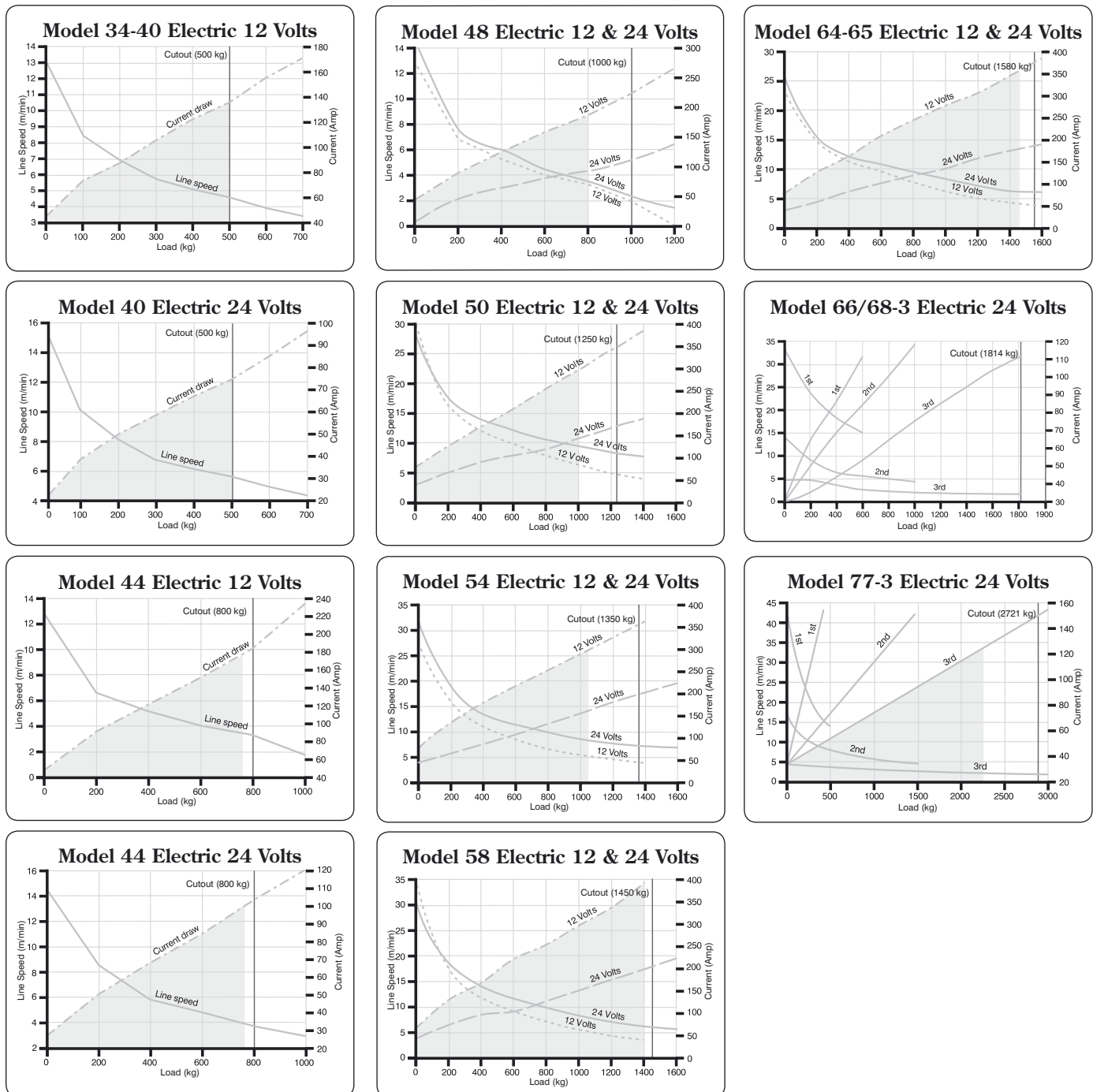

5. Safe working loads

5.1 Optimum rope diameters

Model	Rope Ø (mm)	Rope Ø (in)
34/40	8 to 12	$\frac{5}{16}$ " to $\frac{1}{2}$ "
44/48	8 to 14	$\frac{5}{16}$ " to $\frac{9}{16}$ "
50/54	8 to 16	$\frac{5}{16}$ " to $\frac{5}{8}$ "
58 & 64/65	8 to 18	$\frac{5}{16}$ " to $\frac{11}{16}$ "
66/68	10 to 20	$\frac{3}{8}$ " to $\frac{3}{4}$ "
77	12 to 22	$\frac{1}{2}$ " to $\frac{7}{8}$ "

5.2 Maximum winch load values

Model	Maximum Load (kg)	Maximum Load (lbs)
30/40	795	1750
44	1136	2500
48	1247	2750
50	1363	3000
54	1474	3250
58	1587	3500
64/65	1700	3750
66/68	2727	6000
77	3409	7500

⚠ Maximum safe working loads are recommended to be **NOT MORE** than the those detailed above. This provides an acceptable safety margin for dynamic load surges in extreme sea conditions.

6. Operating your winch

Fig. 6.0.1

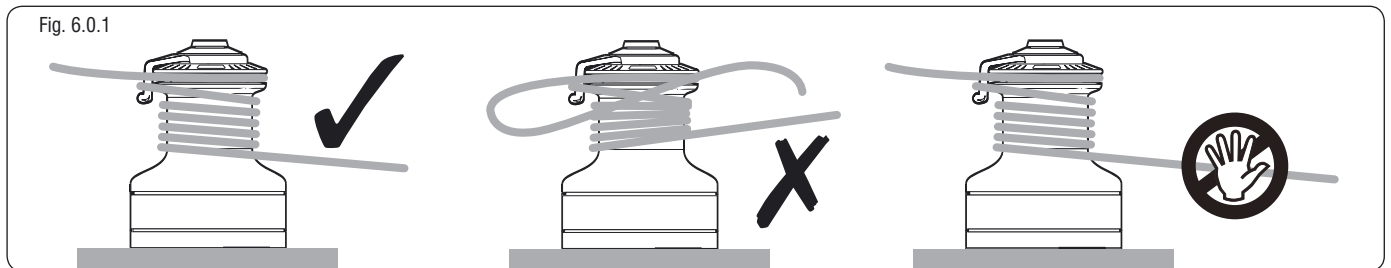

- Ocean Winches 34–65 are single speed powered winches & manual 2 speed, these winches employ an override ratchet gearing for safety when winching manually.
 - Ocean Winches 66–77 are 2 or 3 speed powered and manually operated, they will not drive electrically while the winch lock-in handle is in the drive socket.
1. Adjust the feeder arm so that the rope tails into a secure area away from the incoming line.
 2. There must be at least 3 turns of rope around the winch before being passed across the feeder arm in to the wavespring self tailing jaws.
 3. Use the winch handle or electric switch to operate the winch.

⚠ Remove handle after use.
NEVER hold the incoming rope to the winch while the winch is operated. Only control the rope leaving the winch.

4. Pay out line as per manual winch.

⚠ **ALWAYS** switch off the winch at the circuit breaker/isolator after sailing or when leaving the boat to prevent accidental operation.

7. Servicing your winch

Fig. 7.0.1

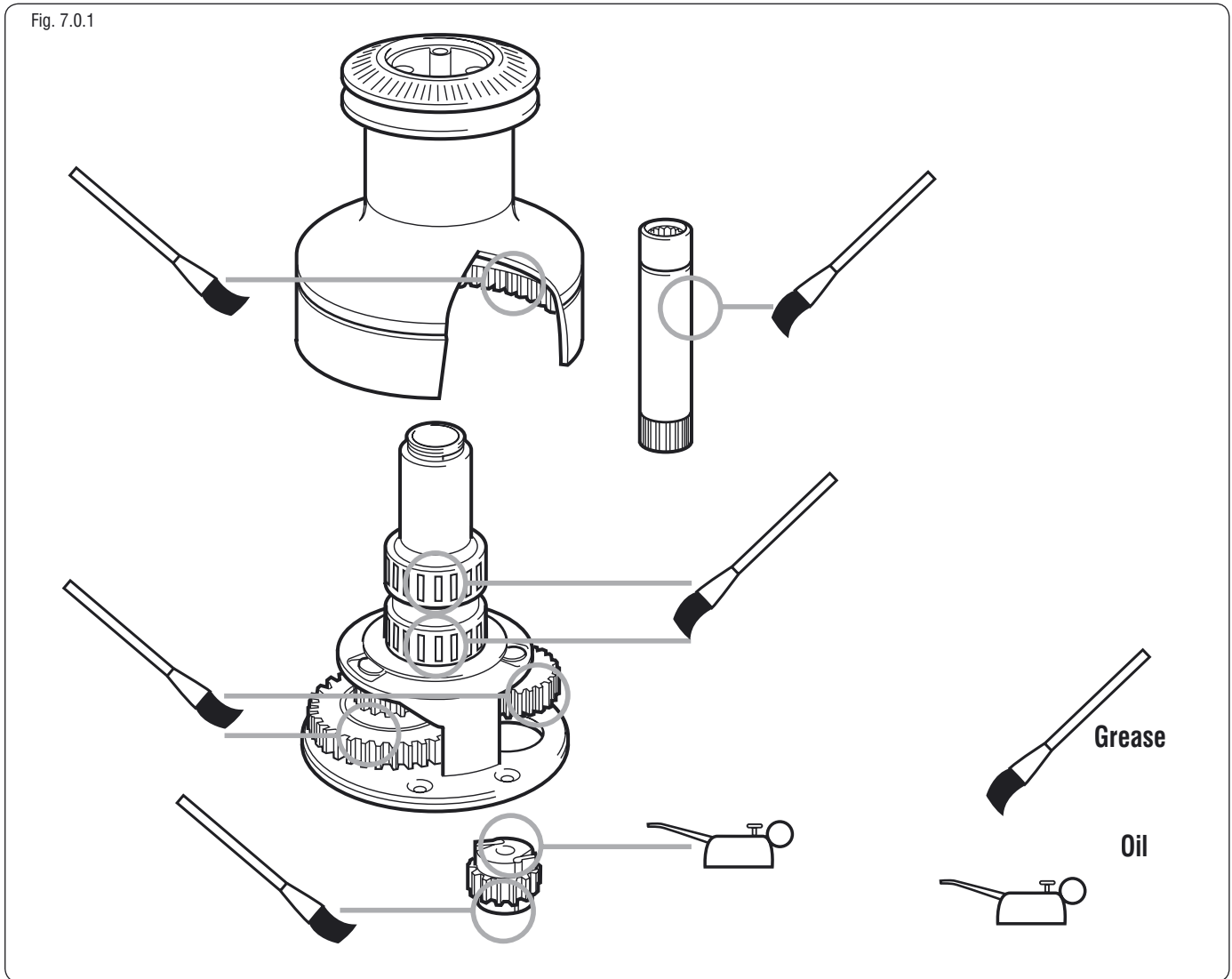

⚠ TURN THE POWER OFF at the circuit breaker/isolator before any maintenance/servicing is carried out. Winches need regular maintenance to operate at peak efficiency otherwise permanent damage and premature wear can result.

⚠ Electric motors become hot during and for some time after use. These units have an oil filled gearbox. **DO NOT** remove the motor.

1. MONTHLY

Hose down with fresh water then lightly oil and grease as per illustration taking care not to get any grease in the pawls as they will stick in operation.

2. TWO OR THREE TIMES DURING ACTIVE SAILING SEASON

Strip, clean, check and relubricate.

3. END OF SEASON OR BEGINNING OF NEW SEASON

Strip, clean, thoroughly check for damage, lubricate and reassemble as detailed in the service manual.

Check condition of motor gearbox. In the event of corrosion, clean and repaint motor with marine grade oil based enamel paint.

- For more details ask for the free booklet and manual "How to Service Your Winch" B 2304 "Winch Parts Manual Volume 10" B 2196 and "Custom Winch Service Manual Volume 8" B2312 (77-144/2) or download from: www.lewmar.com/winchservice.

8. Parts list

8.1 Winch model notes

NOTE: For winches before February 1995.

- Plain bearing 45000248 has replaced the bearings and spacer, these items ARE NOT interchangeable. Contact your Lewmar Dealer.

- On winches 50 to 65 the 2 lower bearings have been replaced by item 45003103 (Plain Bearing). These items ARE interchangeable.

NOTE: Manual winches cannot be converted into electric versions by adding parts listed here.

8.2 Parts list 34-65

Fig. 8.2.1

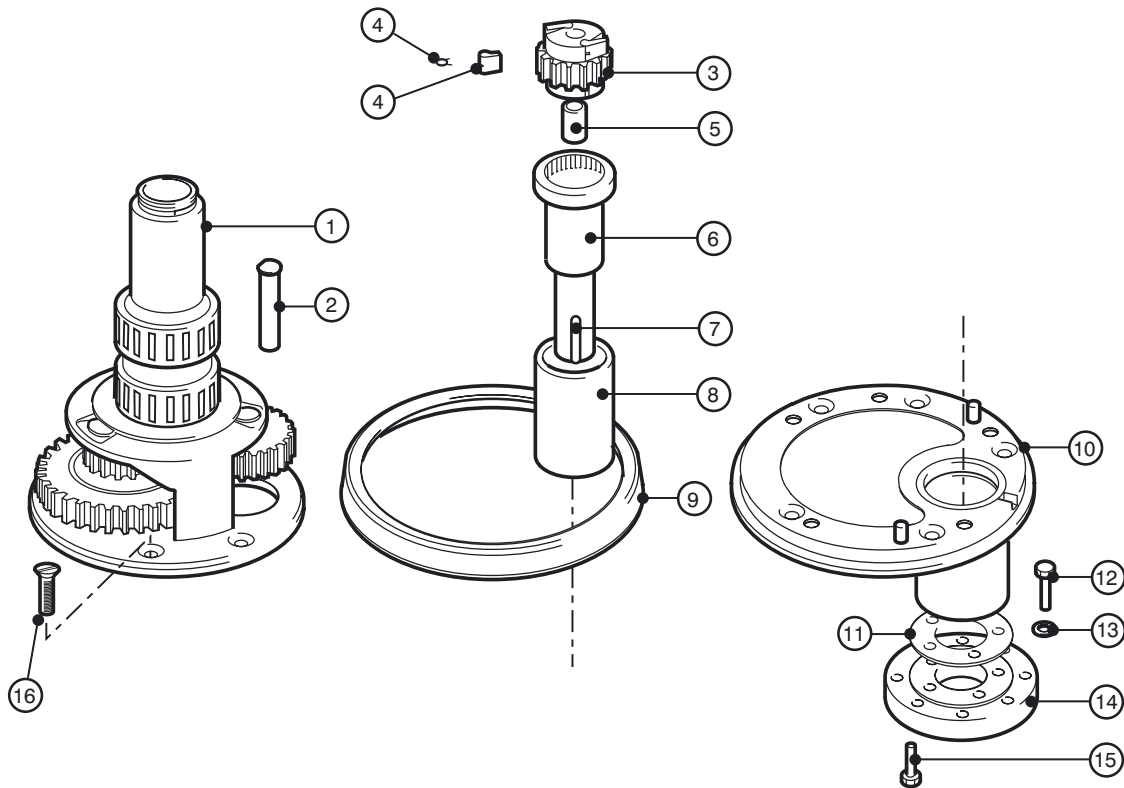

Item	Description	Qty	34	40	44	48	50	54	58	64/65
1	Centre Stem	1	45000265	45000237	45000337	45000437	45000560	45000660	45000760	45000860
2	Gear Spindle	1	45000258	45000241	45000344	45000444	45000544	45000744	45000744	45000744
3	Ratchet Pawl Gear	1	45000288	45000242	45000342	45000342	45000542	45000642	45000742	45000842
4	Pawl	4	15000094	15000094	15000094	15000094	15000301	15000301	15000301	15000301
	Spring	4	1260/7	1260/7	1260/7	1260/7	1260/7	1260/7	1260/7	1260/7
5	Bearing	3	15000378	15000378	15000398	15000398	15000017	15000017	15000017	15000017
6	Drive Shaft	1	45000357	45000357	45000357	45000357	45000543	45000543	45000543	45000543
7	Key	1	15003287	15003287	15003287	15003287	15003287	15003287	15003287	15003287
8	Plain Bearing	1	45000359	45000359	45000358	45000358	45000248	45000248	45000248	45000248
9	Base Plate Cover	1	45000229	45000229	45000329	45000429	45000529	45000529	45000759	45000759
10	Base Plate	1	45000264	45000228	45000328	45000428	45000528	45000528	45000758	45000758
	Dowel	2	45000235	45000235	45000235	45000235	45000581	45000581	45000581	45000581
	Shaft Seal	1	B6234	B6234	B6234	B6234	B6235	B6235	B6235	B6235
11	Insulation Shim	1	45000257	45000257	45000257	45000257	45000257	45000257	45000257	45000257
12	HEX Bolt M8x25	4	B0173	B0173	B0173	B0173	B0173	B0173	B0173	B0173
13	Washer M8	4	B1207	B1207	B1207	B1207	B1207	B1207	B1207	B1207
14	Plate	1	45000350	45000350	45000350	45000350	45000350	45000350	45000350	45000350
15	SKT HD screw M6 x 12	5	B0678	B0678	B0678	B0678	B0678	B0678	B0678	B0678
	CSK HD screw M6 x 16	5	B0524	B0524	-	-	-	-	-	-
	CSK HD screw M8 x 16	6	-	-	B0536	B0536	-	-	-	-
	CSK HD screw M8 x 25	6	-	-	-	-	B0812	B0812	-	-
16	CSK HD screw M10 x 25	5	-	-	-	-	-	B0567	B0567	

8.3 Parts list 66-77

Fig. 8.3.1

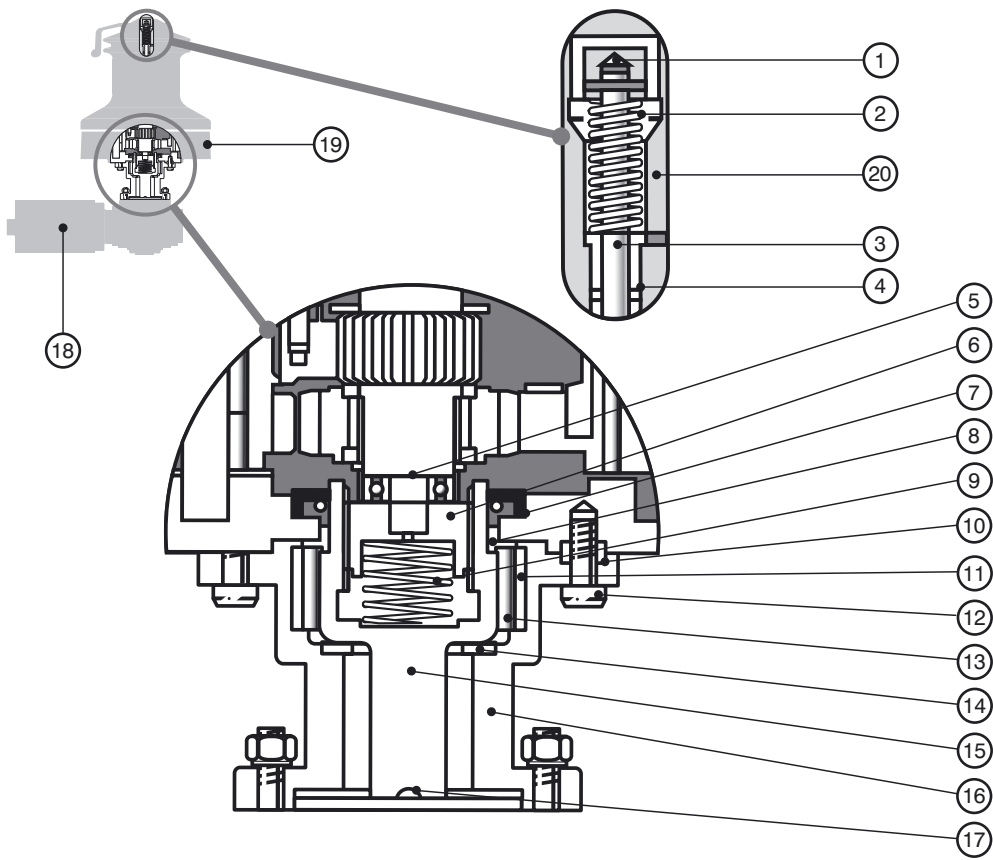

*2 Speed versions shown/detailed

Item	Description	Qty	66/68-*2	77-*2
1	Push Rod Assembly	1	18000181	18000488
2	Spring	1	15044613	15044613
3	'O' Ring	1	B2532	B2532
4	Bush	1	15000184	15000184
5	Spring Clip	1	B9941	B9941
6	Drive Dog	1	15300688	15300575
7	Seal	1	B2593	B2593
8	Thrust Sleeve	1	45002154	45002154
9	Spring	1	15300489	15300489
10	Hollow Dowel	1	45002140	45002140
11	Bush	1	15000569	15000569
12	Screw	4	B0686	B0686
	Heli-coil	4	B2423	B2423
13	Roller Bearing	1	15010007	15010007
14	Thrust Washer	1	15003286	15003286
15	Connecting Shaft	1	45002156	45002156
16	Adaptor	1	45000944	45000944
17	Key	1	15003287	15003287
18	Motor/Gearbox 12 V	1	48000077	48000077
	Motor/Gearbox 24 V	1	48000078	48000078
19	Power Base	1	45000940	45002040
20	Main Spindle - Elec./Hyd.	1	45000947	45002180

9. Dimensions

Fig. 9.0.1

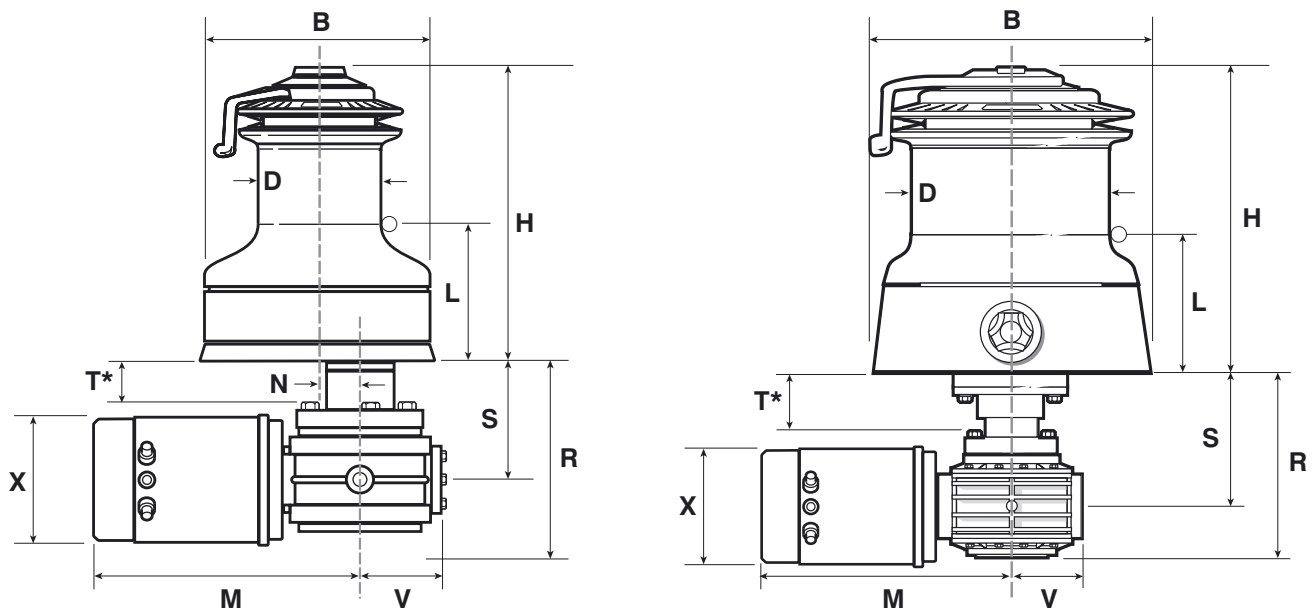

Dimensions in mm	Model	D	B	H	L	M	N	S	T *	R	V	X
	34/40	73.5	154	189.4	95.4	237	38.1	99	33.5	156	70	112
	44	87	174	215.5	103.5	238.5	42	130.5	64.4	186	72.5	112
	48	93	186	228.0	108.5	238.5	44.5	130.5	64.4	186	72.5	112
	50	105	209	258	126	290	48.5	138.5	59.5	182	80	112
	54	105	209	270.8	135.8	290	48.5	138.5	59.5	182	80	112
	58	118	234	286.3	138.8	290	52.9	138.5	59.5	182	80	112
	64/65	118	234	291.3	141.8	290	52.9	138.5	59.5	182	80	112
	66/68	141	282	302.2	142.1	290	-	144	67.5	188.5	80	112
	66-3	141	294	348	170	290	-	144	87.5	191.1	80	112
	77	178	294	348	174	290	-	144	87.5	191.1	80	112
	77-3	178	294	348	174	290	-	147	87.5	191.1	80	112

*Optional extension kits to increase 'T' are available to special order. Contact your nearest Lewmar office if required.

Dimensions in inches	Model	D	B	H	L	M	N	S	T *	R	V	X
	34 & 40	2 ⁷ / ₈	6 ¹ / ₁₆	7 ¹⁵ / ₃₂	3 ⁴⁹ / ₆₄	9 ⁵ / ₁₆	1 ¹ / ₂	3 ⁷ / ₈	1 ⁵ / ₁₆	6 ¹ / ₈	2 ³ / ₄	4 ³ / ₈
	44	3 ⁷ / ₁₆	6 ⁵⁵ / ₆₄	8 ³ / ₈	4 ¹ / ₁₆	9 ²⁵ / ₆₄	1 ⁵ / ₈	5 ⁹ / ₆₄	2 ¹⁷ / ₃₂	7 ¹ / ₄	2 ⁵⁵ / ₆₄	4 ³ / ₈
	48	3 ¹¹ / ₁₆	7 ²¹ / ₆₄	9 ³ / ₈	4 ¹ / ₄	9 ²⁵ / ₆₄	1 ¹ / ₄	5 ⁹ / ₆₄	2 ¹⁷ / ₃₂	7 ¹ / ₄	2 ⁵⁵ / ₆₄	4 ³ / ₈
	50	4 ¹ / ₈	8 ¹ / ₄	10 ¹ / ₈	4 ¹⁵ / ₁₆	11 ⁷ / ₁₆	1 ¹⁵ / ₁₆	5 ⁷ / ₁₆	2 ⁵ / ₁₆	7 ¹ / ₈	3 ¹ / ₈	4 ³ / ₈
	54	4 ¹ / ₈	8 ¹ / ₄	10 ⁵ / ₈	5 ³ / ₈	11 ⁷ / ₁₆	1 ¹⁵ / ₁₆	5 ⁷ / ₁₆	2 ⁵ / ₁₆	7 ¹ / ₈	3 ¹ / ₈	4 ³ / ₈
	58	4 ⁵ / ₈	9 ¹ / ₄	11 ¹ / ₄	5 ¹ / ₂	11 ⁷ / ₁₆	2 ¹ / ₁₆	5 ⁷ / ₁₆	2 ⁵ / ₁₆	7 ¹ / ₈	3 ¹ / ₈	4 ³ / ₈
	64/65	4 ⁵ / ₈	9 ¹ / ₄	11 ¹ / ₂	5 ⁹ / ₁₆	11 ⁷ / ₁₆	2 ¹ / ₁₆	5 ⁷ / ₁₆	2 ³ / ₁₆	7 ¹ / ₈	3 ¹ / ₈	4 ³ / ₈
	66/68	5 ⁹ / ₁₆	11 ¹ / ₈	11 ¹⁵ / ₁₆	5 ⁹ / ₁₆	11 ⁷ / ₁₆	-	5 ⁷ / ₁₆	2 ¹¹ / ₁₆	7 ³ / ₈	3 ¹ / ₈	4 ³ / ₈
	66-3	5 ⁹ / ₁₆	11 ¹ / ₂	13 ¹¹ / ₁₆	6 ¹ / ₁₆	11 ⁷ / ₁₆	-	5 ⁷ / ₁₆	3 ⁷ / ₁₆	7 ¹ / ₂	3 ¹ / ₈	4 ³ / ₈
	77	7	11 ¹ / ₂	13 ¹¹ / ₁₆	6 ⁷ / ₈	11 ⁷ / ₁₆	-	5 ⁷ / ₁₆	3 ⁷ / ₁₆	7 ¹ / ₂	3 ¹ / ₈	4 ³ / ₈
	77-3	7	11 ¹ / ₂	13 ¹¹ / ₁₆	6 ⁷ / ₈	11 ⁷ / ₁₆	-	5 ⁷ / ₁₆	3 ⁷ / ₁₆	7 ¹ / ₂	3 ¹ / ₈	4 ³ / ₈

10. Total weight

Weight in kg	Model	Alloy (kg)	All Bronze (kg)	Chrome (kg)	St. Steel (kg)	All Chrome (kg)
	34/40	19	21.2	20.7	20.5	21.2
	44	23.3	25.8	25.8	25.5	25.8
	48	26	30.1	29.4	28.6	30.1
	50	30	35.7	34.8	34.7	35.7
	54	30.6	37.2	36.4	35.6	37.2
	58	33.4	40.6	39.8	38.1	40.6
	64/65	35.7	43.7	42.9	40.1	43.7
	66/68	42	49.7	48.8	46	49.7
	66-3	48	-	54.8	52	55.7
	77	49.3	-	53.3	53	62.3
	77/3	51.3	-	57.3	55	64.3

Weight in lbs	Model	Alloy (lbs)	All Bronze (lbs)	Chrome (lbs)	St. Steel (lbs)	All Chrome (kg)
	34/40	41.9	46.7	45.6	45.2	46.7
	44	51.4	56.8	56.8	56.2	56.8
	48	57.3	66.4	64.8	63	66.3
	50	66.15	78.7	76.7	76.5	78.7
	54	67.4	82	80.2	78.5	82
	58	73.6	89.5	80.2	84	89.5
	64/65	78.7	96.3	94.6	88.4	96.3
	66/68	92.4	109.3	107.3	101.2	109.3
	66-3	105.6	-	120.6	114.4	122.5
	77	108.5	-	121.7	116.6	137.7
	77/3	112.9	-	126.1	121	141.5

11. Model range

11.1 Model range 34-77

Model	Part No.	Finish	Description
34/40	48034255	Alloy	(Model 34) Deck Unit
	48040255	Alloy	(Model 40) Deck Unit
	48040256	Chrome	Deck Unit
	48040258	St. Steel	Deck Unit
	48040259	All Chrome	Deck Unit
	48040260	All Bronze	Deck Unit
	48000116		12 V Motor/Gearbox
	48000117		24 V Motor/Gearbox
	48000301 or 0052505		12 V 'E' Contactor Box
	48000302 or 0052506		24 V 'E' Contactor Box
	48000081		12 V 'ELS' Control Box
	48000082		24 V 'ELS' Control Box
	48000138		12 V 'EVC' Control Box
	48000139		24 V 'EVC' Control Box
	48040055		Power Drive Kit
	44	48044255	Alloy
48044256		Chrome	Deck Unit
48044258		St. Steel	Deck Unit
48044259		All Chrome	Deck Unit
48044260		All Bronze	Deck Unit
48000116			12 V Motor/Gearbox
48000117			24 V Motor/Gearbox
48000081 or 0052505			12 V 'E' Contactor Box
48000302 or 0052506			24 V 'E' Contactor Box
48000083			12 V 'ELS' Control Box
48000084			24 V 'ELS' Control Box
48000140			12 V 'EVC' Control Box
48000141			24 V 'EVC' Control Box

Model	Part No.	Finish	Description	
48	48048255	Alloy	Deck Unit	
	48048256	Chrome	Deck Unit	
	48048258	St. Steel	Deck Unit	
	48048259	All Chrome	Deck Unit	
	48048260	All Bronze	Deck Unit	
	48000116		12 V Motor/Gearbox	
	48000117		24 V Motor/Gearbox	
	18000301 or 0052505		12 V 'E' Contactor Box	
	18000302 or 0052506		24 V 'E' Contactor Box	
	48000085		12 V 'ELS' Control Box	
	48000086		24 V 'ELS' Control Box	
	48000142		12 V 'EVC' Control Box	
	48000143		24 V 'EVC' Control Box	
	48048055		Power Drive Kit	
	50	48050200	Alloy	Deck Unit
		48050201	Chrome	Deck Unit
48050204		St. Steel	Deck Unit	
48050203		All Chrome	Deck Unit	
48050202		All Bronze	Deck Unit	
48000075			12 V Motor/Gearbox	
48000076			24 V Motor/Gearbox	
N/A			12 V 'E' Contactor Box	
N/A			24 V 'E' Contactor Box	
48000087			12 V 'ELS' Control Box	
48000088			24 V 'ELS' Control Box	
48000144			12 V 'EVC' Control Box	
48000145			24 V 'EVC' Control Box	
48050055			Power Drive Kit	

Model	Part No.	Finish	Description	
54	48054200	Alloy	Deck Unit	
	48054201	Chrome	Deck Unit	
	48054204	St. Steel	Deck Unit	
	48054203	All Chrome	Deck Unit	
	48054202	All Bronze	Deck Unit	
	48000075		12 V Motor/Gearbox	
	48000076		24 V Motor/Gearbox	
	N/A		12 V 'E' Contactor Box	
	N/A		24 V 'E' Contactor Box	
	48000089		12 V 'ELS' Control Box	
	48000090		24 V 'ELS' Control Box	
	48000146		12 V 'EVC' Control Box	
	48000147		24 V 'EVC' Control Box	
	48054055		Power Drive Kit	
	58	48058200	Alloy	Deck Unit
48058201		Chrome	Deck Unit	
48058204		St. Steel	Deck Unit	
48058203		All Chrome	Deck Unit	
48058202		All Bronze	Deck Unit	
48000075			12 V Motor/Gearbox	
48000076			24 V Motor/Gearbox	
N/A			12 V 'E' Contactor Box	
N/A			24 V 'E' Contactor Box	
48000091			12 V 'ELS' Control Box	
48000092			24 V 'ELS' Control Box	
48000148			12 V 'EVC' Control Box	
48000149			24 V 'EVC' Control Box	
48058055			Power Drive Kit	
64/65		48065200	Alloy	(Model 65) Deck Unit
	48064200	Alloy	(Model 64) Deck Unit	
	48064201	Chrome	Deck Unit	
	48064204	St. Steel	Deck Unit	
	48064203	All Chrome	Deck Unit	
	48064202	All Bronze	Deck Unit	
	48000075		12 V Motor/Gearbox	
	48000076		24 V Motor/Gearbox	
	N/A		12 V 'E' Contactor Box	
	N/A		24 V 'E' Contactor Box	
	48000093		12 V 'ELS' Control Box	
	48000094		24 V 'ELS' Control Box	
	48000150		12 V 'EVC' Control Box	
	48000151		24 V 'EVC' Control Box	
	48064055		Power Drive Kit	
66/68 -2 Speed	48066200	Alloy	Deck Unit	
	48066201	Chrome	Deck Unit	
	48066204	St. Steel	Deck Unit	
	48066203	All Chrome	Deck Unit	
	48066202	All Bronze	Deck Unit	
	48000077		12 V Motor/Gearbox	
	48000078		24 V Motor/Gearbox	
	N/A		12 V 'E' Contactor Box	
	N/A		24 V 'E' Contactor Box	
	18000430		12 V 'ELS' Control Box	
	18000431		24 V 'ELS' Control Box	
	N/A		12 V 'EVC' Control Box	
	N/A		24 V 'EVC' Control Box	
	66/68 -3 Speed	48066205	Alloy	Deck Unit
		48066206	Chrome	Deck Unit
48066209		St. Steel	Deck Unit	
48066208		All Chrome	Deck Unit	

Model	Part No.	Finish	Description
77	48077200	Alloy	Deck Unit
	48077201	Chrome	Deck Unit
	48077204	St. Steel	Deck unit
	48077203	All Chrome	Deck Unit
	48077205	Alloy	Deck Unit
77 -3 Speed	48077206	Chrome	Deck Unit
	48077209	St. Steel	Deck Unit
	48077208	All Chrome	Deck Unit
	48000078		24 V Motor/Gearbox
77 & 77 -3 Speed	48000077		12 V Motor/Gearbox
	N/A		12 V 'E' Contactor Box
	N/A		24 V 'E' Contactor Box
	48000022		12 V 'ELS' Control Box
	48000023		24 V 'ELS' Control Box
	N/A		12 V 'EVC' Control Box
	N/A		24 V 'EVC' Control Box

11.2 Circuit breakers

Model	Voltage	Circuit Breaker	Circuit Breaker Part Number
34/40	12 V	90	68000349
	24 V	40	68000542
44	12 V	110	68000350
	24 V	50	68000348
48	12 V	120	68000239
	24 V	70	68000240
50	12 V	150	68000351
	24 V	90	68000349
54	* 12 V	250 FUSE	589008
	24 V	90	68000349
58	* 12 V	325 FUSE	589009
	24 V	110	68000350
64/65	* 12 V	325 FUSE	589009
	24 V	110	68000350
66/68	12 V	110	68000350
	24 V	50	68000348
77	12 V	110	68000350
	24 V	50	68000348

*Order fuse holder 589006 with fuse indicated.

11.3 NEW Electric deck switch

Description	Part Number
UNLIT - Electric deck switch open (Plastic)	68000345
LIT - Electric deck switch open (Plastic)	69000350
LIT - Electric deck switch open (Stainless Steel Lid)	48000170
Labels - Silver out of black (Sailing functions)	69000349
Labels - Black out of silver (Sailing functions) use with 48000170	69000356

12. Fault finding

Fig. 12.0.1

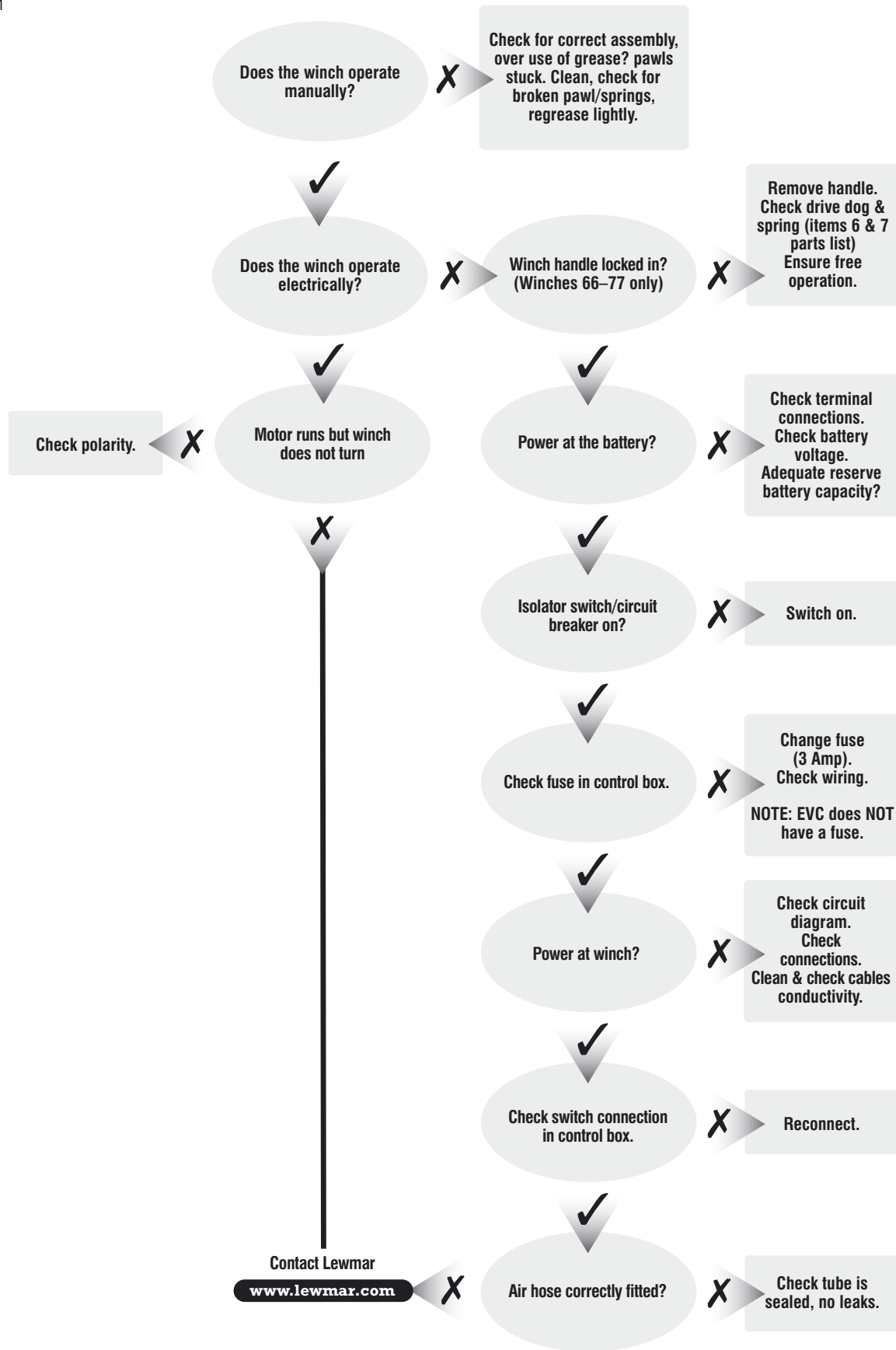

13. Lewmar limited warranty

LIMITED WARRANTY and KEY TERMS OF SUPPLY BY LEWMAR

Lewmar warrants that in normal usage and with proper maintenance its products will conform with their specification for a period of three years from the date of purchase by the end user, subject to the conditions, limitations and exceptions listed below. Any product, which proves to be defective in normal usage during that three-year period, will be repaired or, at Lewmar's option, replaced by Lewmar.

A CONDITIONS AND LIMITATIONS

- i Lewmar's liability shall be limited to the repair or replacement of any parts of the product which are defective in materials or workmanship.
- ii Responsibility for the selection of products appropriate for the use intended by the Buyer shall rest solely with the Buyer and Lewmar accepts no responsibility for any such selection.
- iii Lewmar shall not be liable in any way for Product failure, or any resulting loss or damage which arises from:
 - a use of a product in an application for which it was not designed or intended;
 - b. corrosion, ultra violet degradation or wear and tear;
 - c. a failure to service or maintain the product in accordance with Lewmar's recommendations;
 - d. faulty or deficient installation of the product (unless conducted by Lewmar);
 - e. any modification or alteration of the product;
 - f. conditions that exceed the product's performance specifications or safe working loads.
- iv Product subject to a warranty claim must be returned to the Lewmar outlet which supplied the product for examination unless otherwise agreed by Lewmar in writing.
- v This warranty does not cover any incidental costs incurred for the investigation, removal, carriage, transport or installation of product.
- vi Service by anyone other than authorised Lewmar representatives shall void this warranty unless it accords with Lewmar guidelines and standards of workmanship.
- vii Lewmar's products are intended for use only in the marine environment. Buyers intending to use them for any other purpose should seek independent professional advice as to their suitability. Lewmar accepts no liability arising from such other use.

B EXCEPTIONS

Cover under this Warranty is limited to a period of one year from the date of purchase by the end user in the case of any of the following products or parts of products:

- Electric motors and associated electrical equipment
- Electronic controls
- Hydraulic pumps, valves and actuators
- Weather seals
- Products used in "Grand Prix" racing applications

C LIABILITY

- i Lewmar's liability under this warranty shall be to the exclusion of all other warranties or liabilities (to the extent permitted by law). In particular (but without limitation):
 - a Lewmar shall not be liable for:
 - Any loss of anticipated turnover or profit or indirect, consequential or economic loss ;
 - Damages, costs or expenses payable to any third party;
 - Any damage to yachts or equipment;
 - Death or personal Injury (unless caused by Lewmar's negligence).

Some states and countries do not allow the exclusion or limitation of incidental or consequential damages, so the above limitation or exclusion may not apply to you.

- b Lewmar grants no other warranties regarding the fitness for purpose, use, nature or satisfactory quality of the products.
- ii Where applicable law does not permit a statutory or implied warranty to be excluded, then such warranty, if permitted by that state or country's law, shall be limited to a period of one year from the date of purchase by the end user. Some states and countries do not allow limitations on how long an implied warranty lasts, so this limitation may not apply to you.

D PROCEDURE

Notice of a claim for service under this warranty shall be made promptly and in writing by the end user to the Lewmar outlet which supplied the product or to Lewmar at Southmoor Lane, Havant, Hampshire, England PO9 1JJ.

E SEVERANCE CLAUSE

If any clause of this warranty is held by any court or other competent authority to be invalid or unenforceable in whole or in part, the validity of the remaining clauses of this warranty and the remainder of the clause in question shall not be affected.

F OTHER RIGHTS

This warranty gives you specific legal rights, and you may also have other legal rights, which vary, from state to state and country to country.

In the case of European States a Consumer customer (as defined nationally) has legal rights under the applicable national law governing the sale of Consumer Goods; this Warranty does not affect those rights.

G LAW

This warranty shall be governed by and read in accordance with the laws of England or the state or country in which the first end user is domiciled at the time of purchase of the product.

H DISPUTES

Any dispute arising under this warranty may, at the option of the end-user, be referred to alternative dispute resolution under the rules of the British Marine Federation or to the Courts of the State whose law shall govern the warranty or to the Courts of England and Wales.

The British Marine Federation may be contacted at Marine House, Thorpe Lea Road, Egham, England, TW20 8BF



www.lewmar.com

© Copyright 2006 Lewmar Ltd. All rights reserved.

B2303

Produced by T. Connell UK (+44) 023 9263 9265 Ref:11712/03/2006

Free Manuals Download Website

<http://myh66.com>

<http://usermanuals.us>

<http://www.somanuals.com>

<http://www.4manuals.cc>

<http://www.manual-lib.com>

<http://www.404manual.com>

<http://www.luxmanual.com>

<http://aubethermostatmanual.com>

Golf course search by state

<http://golfingnear.com>

Email search by domain

<http://emailbydomain.com>

Auto manuals search

<http://auto.somanuals.com>

TV manuals search

<http://tv.somanuals.com>