

Lexmark Photo Jetprinter 5770 User Guide

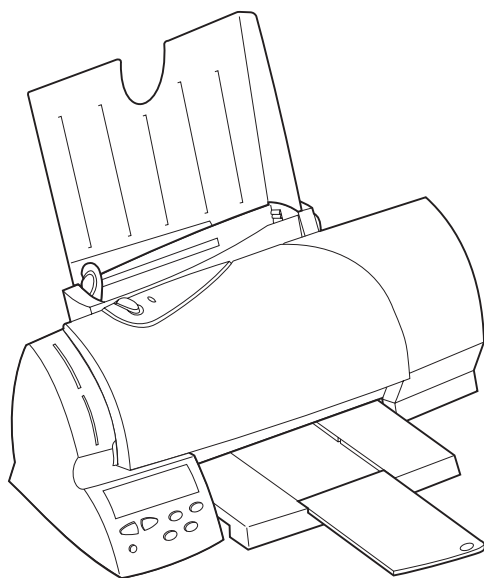

First Edition (July 1998)

The following paragraph does not apply to any country where such provisions are inconsistent with local law: LEXMARK INTERNATIONAL, INC. PROVIDES THIS PUBLICATION "AS IS" WITHOUT WARRANTY OF ANY KIND, EITHER EXPRESS OR IMPLIED, INCLUDING, BUT NOT LIMITED TO, THE IMPLIED WARRANTIES OF MERCHANTABILITY OR FITNESS FOR A PARTICULAR PURPOSE. Some states do not allow disclaimer of express or implied warranties in certain transactions, therefore, this statement may not apply to you.

This publication could include technical inaccuracies or typographical errors. Changes are periodically made to the information herein; these changes will be incorporated in later editions. Improvements or changes in the products or the programs described may be made at any time.

A form for reader's comments is provided at the back of this publication. If the form has been removed, comments may be addressed to Lexmark International, Inc., Department F95/035-3, 740 New Circle Road N.W., Lexington, Kentucky 40550, U.S.A. In the United Kingdom and Eire, send to Lexmark International Ltd., Marketing and Services Department, Westhorpe House, Westhorpe, Marlow Bucks SL7 3RQ. Lexmark may use or distribute any of the information you supply in any way it believes appropriate without incurring any obligation to you. You can purchase additional copies of publications related to this product by calling 1-800-553-9727. In the United Kingdom and Eire, call 0628-481500. In other countries, contact your point of purchase.

Lexmark, and Lexmark with diamond design are trademarks of Lexmark International, Inc., registered in the United States and/or other countries.

Color Jetprinter is a trademark of Lexmark International, Inc.

Photo Jetprinter is a trademark of Lexmark International, Inc.

Windows is a registered trademark of Microsoft in the U.S. and other countries.

PCL[®] is a registered trademark of the Hewlett-Packard Company. PCL 3 is Hewlett-Packard Company's designation of a set of printer commands (language) and functions included in its printer products. This printer is intended by Lexmark International, Inc. to be compatible with the PCL 3 language. This means that the printer recognizes PCL 3 commands used in various application programs, and that the printer emulates the functions corresponding to the commands.

Other trademarks are the property of their respective owners.

**© Copyright Lexmark International, Inc. 1998.
All rights reserved.**

UNITED STATES GOVERNMENT RESTRICTED RIGHTS

This software and documentation are provided with RESTRICTED RIGHTS. Use, duplication or disclosure by the Government is subject to restrictions as set forth in subparagraph (c)(1)(ii) of the Rights in Technical Data and Computer Software clause at DFARS 252.227-7013 and in applicable FAR provisions: Lexmark International, Inc., Lexington, KY 40550.

Contents

Chapter 1 - Introducing your printer	1
Printer features and specifications	2
System requirements	4
Using the printer's light and button	5
Chapter 2 - Using the printer software	7
Opening the Control Program	8
Opening the Printer Driver	8
Chapter 3 - Loading paper and other media	9
Recommended paper types	9
Loading the automatic feeder	14
Loading the manual feeder	18
Chapter 4 - Caring for your print cartridges	21
Preserving print cartridges	21
Installing or replacing print cartridges	22
Disposing of used cartridges	26
Aligning the print cartridges	27

Cleaning the print nozzles	29
Wiping the print nozzles and contacts	30
Cleaning print cartridge carrier contacts	32

Chapter 5 - Printing from DOS **35**

Changing print settings for DOS applications	35
Printing from DOS applications	36

Chapter 6 - Troubleshooting **43**

Bidirectional communications problems	44
Printhead failure	47
Deleting photo files	49
Error messages on your computer	50
Error messages on the printer operator panel	51
General printing problems	52
Paper feed problems	57
Poor print quality	59
Printer software problems	63
Removing the exit tray	64

Chapter 7 - Ordering Supplies **65**

Print cartridges	65
Parallel cable	65
Photo paper	66
Coated paper	66
Glossy film	67
Transparencies	67
Greeting cards with envelopes	68
Labels	68

Iron-on transfers for T-shirts 69

Appendix A - Notices71

Appendix B - Statement of Limited Warranty .79

Contents

Introducing your printer

Chapter One

Your printer is a general purpose color inkjet printer that provides high quality text and photos. You can use your printer all by itself to print photos, or connect to your computer when you want to print on single sheet paper, envelopes, labels, index cards, coated paper, glossy film, photo paper, transparencies, greeting cards, and iron-on transfers.

This User's Guide describes how to use your printer with a computer. For information about using your printer all by itself, refer to the *Getting Started* booklet that tells you how to use your printer without a computer.

This illustration shows the parts of the printer.

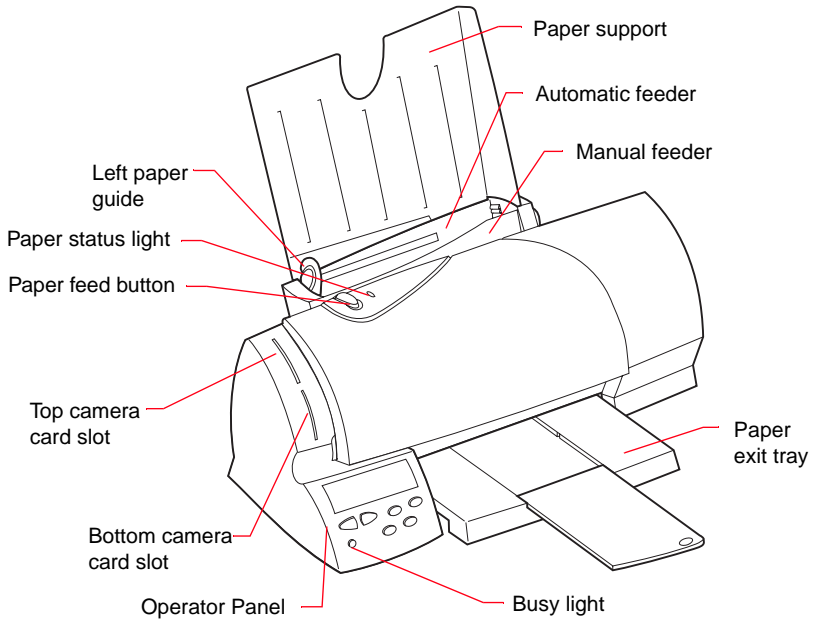

Printer features and specifications

Your printer features:

- Multiple print quality options that include High Quality, Quality, and Normal.
- Direct digital input function which allows you to download directly from the camera cards into the printer.
- Camera card support for most digital cameras.
- Index printing of thumbnail images.
- Zip drive compatibility for storage support.

- Superior editing and formatting options.
You can edit your photos to produce panoramic or cropped prints. You can also print your photos in multiple photos per page formats.
- On-screen or verbal feedback of printer status.
- Low cost, near laser-quality print.
- Quiet operation.
- Portrait and landscape orientation.
- Low-ink messages when the print cartridge is low on ink and connected to a computer.
- Superior paper handling in the industry for this class of printer.
Your printer also supports index cards, labels, envelopes, transparencies, plain paper, coated paper, and hagaki.
- Support for these new paper types: iron-on transfers, greeting cards, and glossy film or photo paper.
- Automatic envelope feeding.

Printer dimensions

- Height:** 5.0 in. (152 mm)
Width: 17.0 in. (432 mm)
Depth: 8.0 in. (203 mm)
Weight: 9.0 lbs. (4.1 kg)

Temperature and humidity

Print quality can vary depending on air temperature and relative humidity.

- Operating temperature range: 10° to 40°C (50° to 104°F)
- Optimum print temperature range: 16° to 32°C (60° to 90°F)
- Operating humidity range: 8% to 80% RH (non-condensing)
- Optimum humidity range: 20% to 60% RH

System requirements

If you are using your printer with a computer, make sure you:

- Are running Windows 95 or Windows 98.
- Have a 486 PC system or higher.
- Have at least 8 MB RAM.
- Have at least 20 MB free disk space.

Using the printer's light and button

Your printer has two sets of lights and buttons:

- One set is located at the bottom left-hand corner of the printer, on the operator panel. For more information on the operator panel light and buttons, refer to the *Getting Started* booklet that tells you how to set up and use your printer without a computer.
- The other set is located at the top of your printer and includes the Paper Status light and the Paper Feed button.

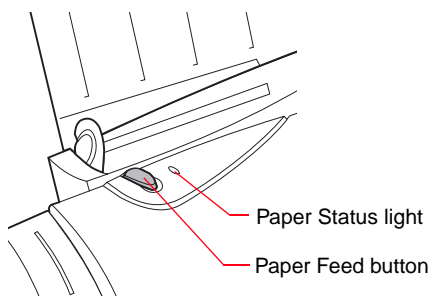

Paper Status light

If the light is:	Then the printer is:
Off	Ready to print
On solid	Printing or feeding media through the printer
Blinking	Out of paper or has an error

Paper Feed button

Use the Paper Feed button to feed paper into the printer when you run out of paper during a print job and the Paper Status light blinks.

If you run out of paper during a print job:

- 1** Load paper.
- 2** Press the Paper Feed button.

Note: You do not need to press the Paper Feed button in order to get the printer to load the paper under normal conditions.

Using the printer software

Chapter Two

When you installed the software for your printer, several small applications were installed on your computer. The following table describes these applications:

Use this software:	When you want to:
Control Program	<ul style="list-style-type: none">• install or replace print cartridges• align print cartridges• monitor print jobs and print cartridge ink levels• print a test page• change DOS settings• control when and how the Control Program appears
Printer Driver	<ul style="list-style-type: none">• change printer properties• choose the paper source• choose page orientation• choose different sizes and types of media• adjust the quality of print jobs• reset printer defaults

Opening the Control Program

- 1 From the **Start** menu, click **Programs**.
- 2 Click the Lexmark 5700 Series program group.
- 3 Click **Lexmark 5700 Ctrl Prog on LPTx**.

Opening the Printer Driver

You can open the printer driver from almost any application. To open the printer driver:

- 1 Open the application's **File** menu.
- 2 Choose **Print** (or **Printer**) **Setup**.
- 3 In the Printer Setup dialog box, click the **Properties**, **Options**, or **Setup** button (depending on the application).

Loading paper and other media

Chapter Three

Your printer prints on photo paper, coated paper, envelopes, index cards, labels, transparencies, paper, iron-on transfers, glossy film, and greeting cards. This section includes general guidelines for purchasing and loading print materials.

Recommended paper types

This section describes photo paper, coated paper, transparency, paper, envelope, index card, label, greeting card, and iron-on transfer types and sizes you can use with your printer.

Note:

- Use the Photo print cartridge shipped with your printer to print on photo paper and glossy film.
- Use a Black print cartridge to print on all other paper types. (To purchase a Black print cartridge from Lexmark, use part number 12A1970.)

Photo paper types and sizes

For best photo print results using Color and Photo print cartridges, use photo paper designed for an inkjet printer, such as the following:

Type	Size	Part number
Photo paper	Letter (20-pack)	1372481
	A4 (20-pack)	1372208
*	4x6 cards (20-pack)	12A0074

* You can purchase other excellent photo papers in both snapshot sizes (4x6, A6, Hagaki) and letter sizes. Since the quality of photo paper varies widely, you should test the print quality before buying large quantities of paper.

Do not use photo paper designed for copiers, laser printers, or pen plotters.

For best results:

- Handle only on the edges. Do not touch the side being printed on.
- Store unused paper in the original packaging.
- Do not store in excessively hot or humid areas.
- Feed photo paper one sheet at a time.
- Be careful not to touch the printed surface until the ink is dry.
- If you are printing several sheets, remove each sheet as it exits the printer and allow it to dry before stacking.
- Cover the printed area with plain paper when storing.

Coated paper types and sizes

Coated paper gives excellent photo printing results at lower costs compared to the heavier photo papers. Use a coated paper designed for inkjet printers, such as Lexmark's High Resolution Premium Inkjet paper. To order this paper from Lexmark, use Lexmark part number 1402780 (letter size) or 1402781 (A4 size).

Plain paper

You can get good print quality on many types of plain paper. Since the quality of plain paper varies widely, you should test the print quality before buying large quantities of paper.

You can use letter, legal, A4, A5, A6, B5, executive, and index card size paper with your printer.

Use paper that meets the following specifications:

- Automatic feeder:

Length	127 to 432 mm	5.0 to 17.0 in.
Width	76 to 216 mm	3.0 to 8.5 in.
Weight	60 to 90 g/sqm	16 to 24 lb.
Thickness	0.071 to 0.18 mm	0.0028 to 0.007 in.

- Manual feeder:

Length	127 to 432 mm	5.0 to 17.0 in.
Width	76 to 228 mm	3.0 to 9.0 in.
Weight	60 to 120 g/sqm	16 to 32 lb.
Thickness	0.071 to 0.18 mm	0.0028 to 0.007 in.

Envelope types and sizes

The printer supports the following envelope sizes and card types:

Envelope Sizes			Card Types
• 6 3/4	• #10	• C6	• Postcard
• 7 3/4	• DL	• B5	• Index card
• #9	• C5	• Baronial	

Do not use envelopes that have:

- Windows, holes, perforations, cutouts, or deep embossing
- A metal clasp, a string tie, or metal folding bars
- Peel-off sealing strips
- Contents enclosed

Transparency types and sizes

The printer supports letter and A4-size transparencies. Use transparencies designed for an inkjet printer, such as the following:

Type	Size	Part number
Transparency	Letter (20-pack)	1402797
	A4 (20-pack)	1402798

Do not use transparencies designed for copiers, laser printers, or pen plotters.

For best results:

- Handle only on the edges. Do not touch the side being printed on.
- Store unused paper in the original packaging.
- Do not store in excessively hot or humid areas.
- Feed transparencies one sheet at a time.

- Be careful not to touch the printed surface until the ink is dry.
- If you are printing several sheets, remove each sheet as it exits the printer and allow it to dry before stacking.
- Cover the printed area with plain paper when storing.

Label types and sizes

The printer supports letter and A4 size label sheets. You can use the automatic feeder or manual feeder to print labels.

Label size	Number of labels per sheet	Sheet size	Part number
1 x 2 5/8 in.	30	Letter	70X7250
2 x 4 in.	10	Letter	70X7251
63.5 x 38.1 mm	21	A4	70X7252
99.1 x 67.7 mm	8	A4	70X7253

For best results, labels used in the printer should meet the following requirements:

- Do not use label sheets with a slick backing material.
- Be sure the adhesive does not come in contact with any part of the printer.
- Use full label sheets. Partially used sheets (with areas exposed by missing labels) can cause labels to peel off during printing and can damage the printer.

Greeting card types and sizes

Use Lexmark Inkjet Greeting Cards, part number 1372482 (letter) or 70X7254 (A4). Each greeting card comes with an envelope.

Iron-on transfer types and sizes

To create colorful, custom-designed T-shirts, use Lexmark Iron-On Transfers, part number 1372480 (letter) or 1402519 (A4).

Loading the automatic feeder

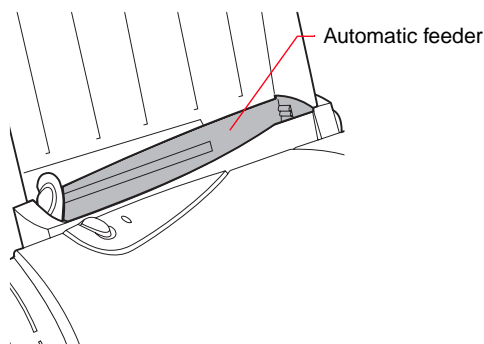

Depending on the thickness of the media, the printer can hold approximately:

- 100 sheets of paper
- 25 transparencies, glossy film, or photo paper
- 10 envelopes, thick paper, or card stock

Paper, transparencies, glossy film, and labels

To load paper, transparencies, glossy film, photo paper, or labels in the automatic feeder:

- 1 Extend the paper exit tray.

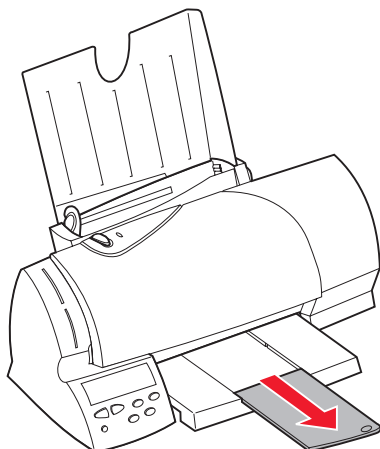

- 2 Place the paper or other media against the right side of the automatic feeder.

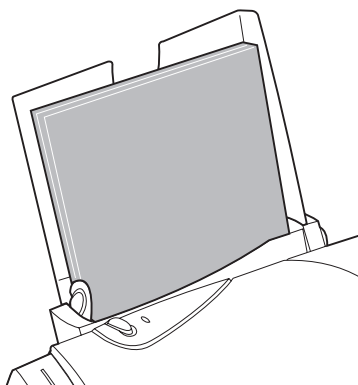

- If the media has a preferred print side, insert with the print side facing you.
- Insert letterhead with the top of the page pointing down.
- Insert transparencies with a removable stripe so the stripe is away from you and pointing down.

Note: You do not need to push paper into the printer or press the Paper Feed button for the printer to load paper!

- 3** *Squeeze* the release tab and the left paper guide together, and slide the left paper guide to the edge of the paper.

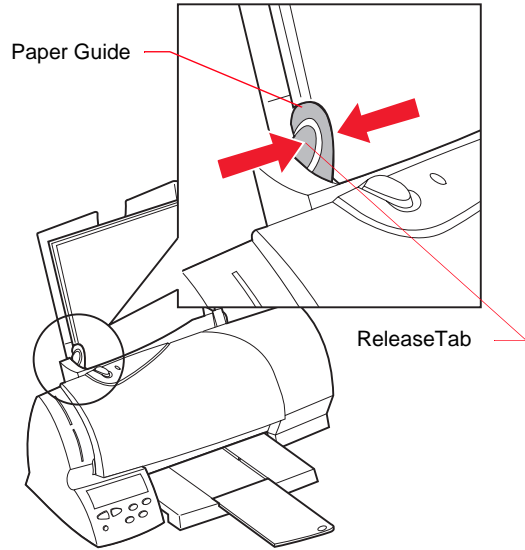

You are now ready to print.

Loading envelopes or other print media

To load envelopes, thick paper, or other card stock in the automatic feeder:

- 1** Remove any paper from the automatic feeder.
- 2** Place the envelopes or other card stock against the right edge of the automatic feeder.
 - Always place the preferred print side facing you.
 - Insert envelopes so that the stamp location is in the lower right-hand corner.

- Insert index cards or postcards vertically so the shortest side feeds into the printer first.

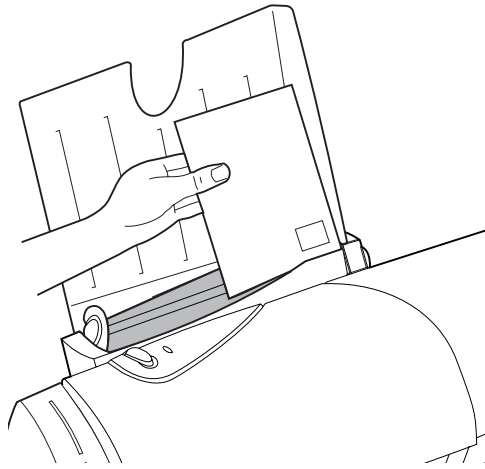

- 3** *Squeeze* the release tab and the paper guide together, and slide the paper guide to the right until it rests against the envelopes or card stock.

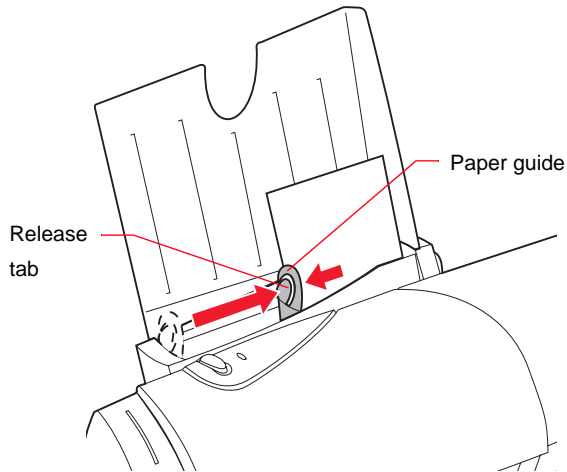

- 4** Before you send a job to print, choose the appropriate paper size and paper type in the Lexmark printer software.

Loading the manual feeder

You can print from the manual feeder without removing paper or envelopes from the automatic feeder. The manual feeder allows you to print **one sheet of print media at a time**.

Loading paper or other print media

- 1 Extend the paper exit tray.

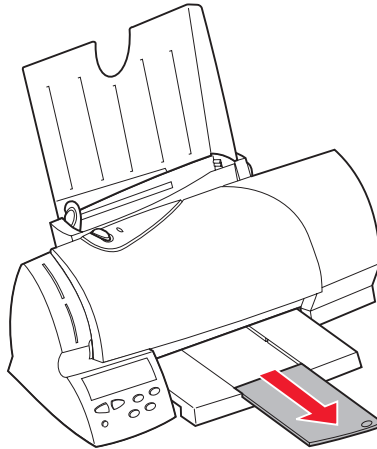

- 2 Locate the manual feeder.

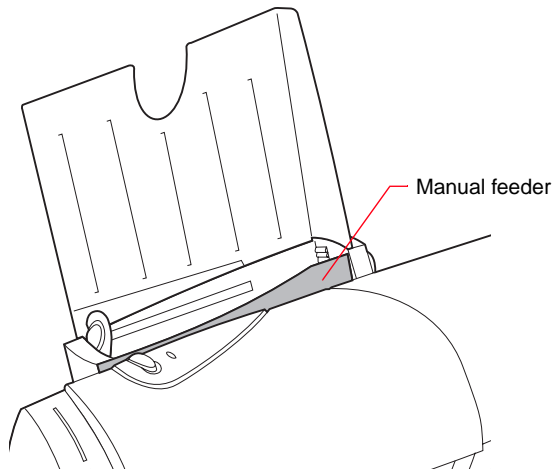

- 3** Place **one** piece of paper or specialty media against the right edge of the manual feeder.
 - Always place the preferred print side facing you.
 - Insert paper or other media against the right edge of the manual feeder.
 - Insert an envelope so that the return address is in the upper right-hand corner.
 - Insert an index card or postcard vertically so the shortest side is fed into the printer first.
 - Insert transparencies with a removable stripe so the stripe is away from you and pointing down.
 - Remove each transparency or glossy film from the paper exit area before the next one is printed to avoid smearing
- 4** Push the media downward until the printer automatically loads it.

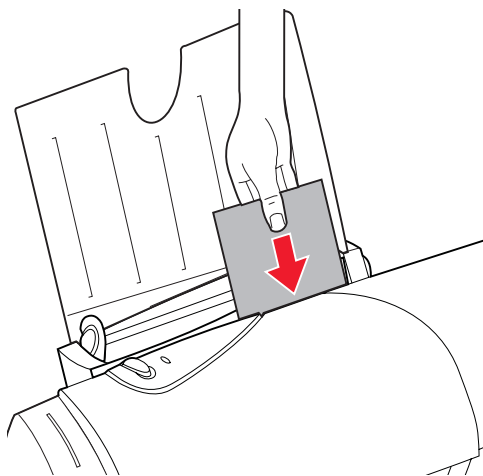

- 5** Before you send a job to print, choose the appropriate paper size and paper type in the Lexmark printer software.

Caring for your print cartridges

Chapter Four

This chapter describes print cartridge maintenance procedures to help you get the best performance from your print cartridge and your printer.

Preserving print cartridges

To ensure the longest life from your print cartridge and optimum performance from your printer:

- Keep a print cartridge in its packaging until you are ready to install it.
- Do not remove a print cartridge from the printer except to replace, clean, or store it in a print cartridge storage unit. The print cartridge will not print correctly if removed from the printer and left exposed for an extended period of time.
- If a print cartridge runs out of ink, leave the empty cartridge in the printer until you are ready to replace it. Printing with one of the print cartridge carriers empty may cause printer problems.
- Do not refill print cartridges. Refilling empty print cartridges invalidates your warranty. Incompatible inks can cause damage to the printhead or to the printer. For best results, use Lexmark supplies with the printer.

Installing or replacing print cartridges

The following procedures are for installing or replacing a print cartridge when your printer is connected to a computer. If you are using your printer without a computer, you can install or replace print cartridges through the operator panel. For help, see the *Getting Started* booklet that tells you how to use your printer without a computer.

Perform the entire print cartridge replacement procedure without interruption.

If you are interrupted and leave the print cartridge carrier in the load position for more than three minutes, the carrier returns to the far right position. The Cartridges Tab remains displayed on your screen.

- If you have not inserted the new cartridge, click Cancel and begin the installation process again.
- If you have inserted the new cartridge, click New Cartridge Installed.

Removing a print cartridge

If you need to remove a print cartridge before you install a different one, follow these steps:

- 1** Open the printer front cover.
- 2** From the printer's Control Program, click the **Cartridges Tab**.

For help opening the Control Program, see "Opening the Control Program" on page 8.

- 3** Click **Install Color Cartridge**, **Install Black Cartridge**, or **Install Photo Cartridge**.

The print cartridge carrier moves to the load position and the Change Cartridge dialog box appears on your computer screen.

If you are installing a Photo or Black cartridge, a Change Cartridge screen appears. Choose the type of cartridge you are installing.

- 4 At the printer, pull the handle of the print cartridge you are replacing toward you until you hear a snap.

The following table lists the correct position for each cartridge type.

Cartridge type	Cartridge carrier slot
Color	left
Photo or Black (optional)	right

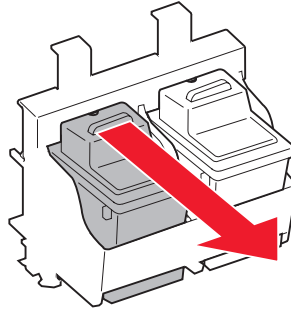

- 5 Remove the print cartridge by lifting it straight out of the printer.

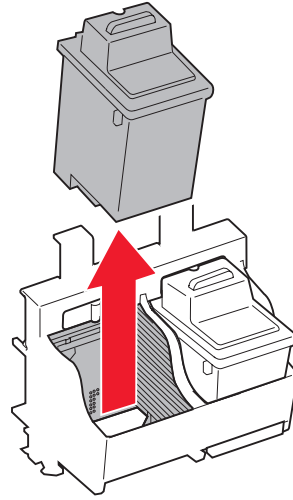

Installing or changing a print cartridge

If necessary, follow the steps for “Removing a print cartridge” on page 22 before proceeding.

- 1 If you are installing a new print cartridge, remove it from its packaging.

Carefully remove the sticker and transparent tape covering the gold contact area from the cartridge.

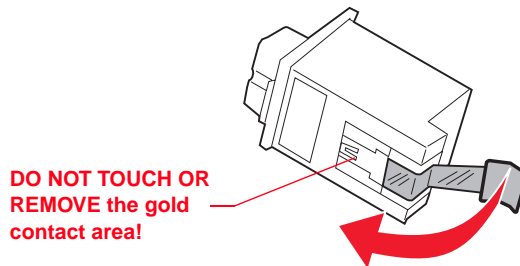

- 2** Insert the replacement print cartridge in the print cartridge carrier.

The following table lists the correct position for each cartridge type.

Cartridge type	Cartridge carrier slot
Color	left
Photo or Black (optional)	right

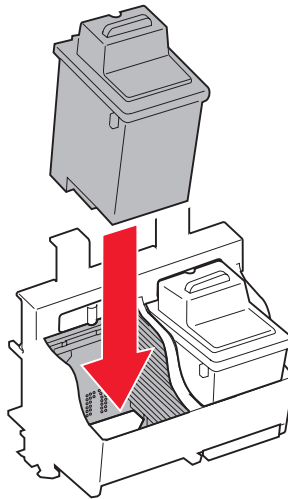

- 3** Push **back** firmly on the cartridge until it *snaps* securely into place.

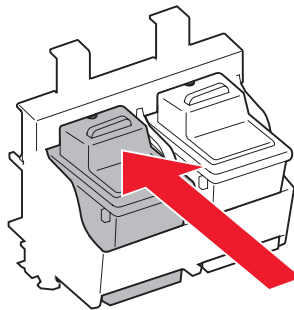

If the print cartridge moves loosely in the carrier, it is not locked into place. Repeat this step.

- 4 From the Cartridges tab, choose the appropriate selection for the cartridge you installed.

If you installed:	Click:
a new Black cartridge	Black Cartridge, P/N 12A1970 New Cartridge Installed
an old Black cartridge	Black Cartridge, P/N 12A1970 Old Cartridge Installed
a new Color cartridge	Color Cartridge, P/N 12A1980 New Cartridge Installed
an old Color cartridge	Color Cartridge, P/N 12A1980 Old Cartridge Installed
a new Photo cartridge	Photo Cartridge, P/N 12A1990 New Cartridge Installed
an old Photo cartridge	Photo Cartridge, P/N 12A1990 Old Cartridge Installed

- 5 If you installed an old print cartridge, go to step 6.
If you installed a new print cartridge, align the print cartridges. For instructions, see “Aligning the print cartridges” on page 27.
- 6 Close the printer front cover.

Disposing of used cartridges

Do not shake used print cartridges. The remaining ink can leak. Before discarding the used print cartridge, put it in a leak-proof bag.

Aligning the print cartridges

Use the printer software to align the print cartridges when:

- You install the printer software on your computer.
- You re-connect the printer to your computer - even if you have aligned them from the operator panel.
- You are using optional Black and Color print cartridges, and the black portions of a graphic or text do not align properly with the color portions.

Below are examples of aligned and misaligned print cartridges:

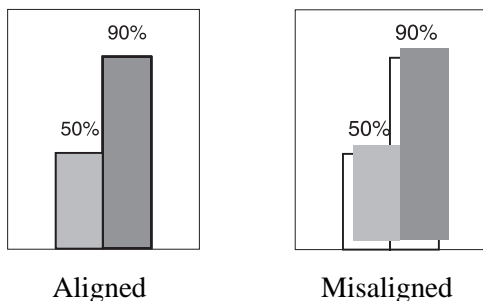

To align your print cartridges for best print quality:

- 1** From the printer's Control Program, click the **Cartridges Tab**.
For help opening the Control Program, see "Opening the Control Program" on page 8.
- 2** Click the **Align Cartridges** button.

The Align Cartridge dialog box appears on your screen. Depending on the cartridge combination you have installed in your printer, a test page with one or more alignment patterns is printed. Each pattern has a number under it.

Below are example test patterns. If you are installing a Color and Photo cartridge set, only test patterns A and B appear on your screen.

A



B



C

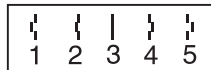

D

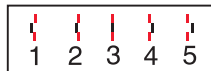

- 3** From each alignment group on the test page, locate the number under the alignment pattern that comes closest to forming a perfectly straight line.

For example, in sample group A above, pattern 5 comes closest to forming a straight line.

- 4** In the Align Cartridges dialog box, enter the numbers from the printed test page (that you chose in step 3) as the appropriate alignment settings.
- 5** After you have entered a number for all of the patterns, click **OK**.
- 6** Repeat steps 2-5 until the patterns print to your satisfaction.

Cleaning the print nozzles

The print cartridge nozzle test helps you pinpoint any clogged nozzles. The nozzle test also cleans the print cartridge by cleaning (purging) the nozzles. A test line prints so you can see if the cleaning process was successful.

Use the nozzle test:

- When you suspect the nozzles are clogged
- When characters are not printing completely

To run the nozzle test:

- 1** Make sure there is paper in the automatic feeder.
- 2** From the printer's Control Program, click the **Cartridges Tab**.

For help opening the Control Program, see "Opening the Control Program" on page 8.

- 3** Click the **Clean Print Nozzles** button.

The printer feeds a sheet of paper and prints a nozzle test pattern, similar to the one shown below.

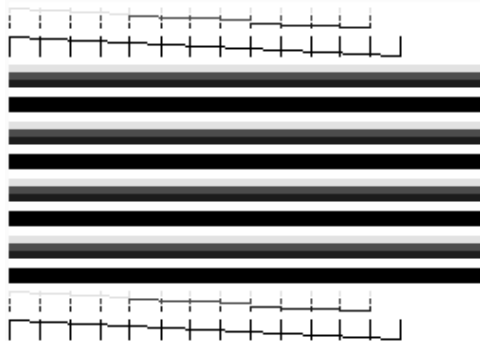

- 4** Examine the test pattern.

The example above shows a test pattern of all nozzles functioning correctly.

- 5** Compare the diagonal line above the printed bars to the diagonal line below the printed bars.

Look for a break in the diagonal lines. A broken line indicates clogged nozzles.

If the bottom line has fewer breaks, or better print quality than the top line, run the test two more times. If the print quality is satisfactory after running the test three times, the print nozzles are clean. You do not need to complete the remaining steps.

If the print quality of both lines is not satisfactory after running the test three times, go to step 6.

- 6** Remove and reinstall the print cartridge.
- 7** Repeat the nozzle test.
- 8** If the lines are still broken, wipe the print cartridge nozzles. For instructions, see “Wiping the print nozzles and contacts”.

Wiping the print nozzles and contacts

If print quality does not improve after cleaning the print nozzles (see “Cleaning the print nozzles” on page 29), the problem may be caused by dried ink on the print cartridge nozzles.

To wipe the print cartridge’s nozzles and contacts:

- 1** Remove the print cartridge from the printer.
For help, see “Removing a print cartridge” on page 22.
- 2** Use a clean cloth, dampened with water only, to gently clean the entire copper colored area, including the nozzles and contacts.

When cleaning the color print cartridge, wipe the nozzles in one direction so the colors do not mix.

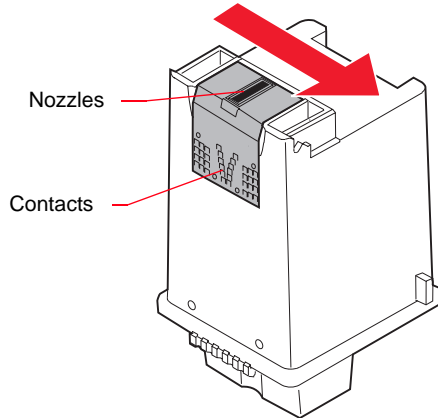

To dissolve dried ink, hold the damp cloth against the nozzles for about three seconds. Gently blot and wipe dry.

- 3** Allow the gold-colored area to dry.
- 4** Reinstall the print cartridge and repeat the nozzle test. For help, see “Cleaning the print nozzles” on page 29.
- 5** If the nozzle test line is still broken, clean the print cartridge carrier contacts. For help, see “Cleaning print cartridge carrier contacts” on page 32.

Cleaning print cartridge carrier contacts

Clean the print cartridge carrier contacts only if you have cleaned and wiped the print nozzles and print quality is still unsatisfactory.

To clean the print cartridge carrier contacts:

- 1** From the printer's Control Program, click the **Cartridges Tab**.
For help opening the Control Program, see "Opening the Control Program" on page 8.
- 2** From the Cartridges Tab, click the **Install Color Cartridge** button to move the print cartridge carrier to the load position.
- 3** Unplug the printer power cord. This forces the print cartridge carrier to remain in the load position.
- 4** Open the printer front cover.
- 5** Remove both print cartridges.
- 6** Use a clean, dry cloth to clean the cartridge carrier contacts inside the printer.

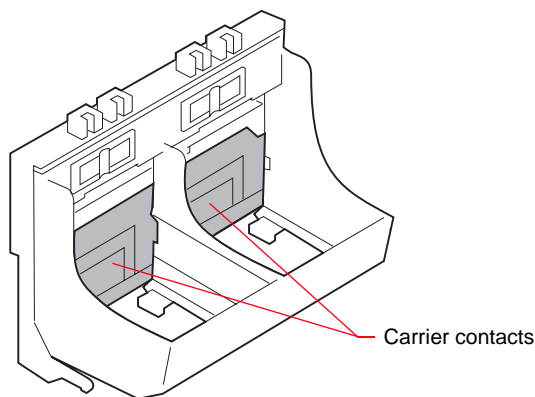

- 7** Replace the print cartridges.
- 8** Close the printer front cover.

- 9** Plug the printer power cord into an electrical outlet.
- 10** You do not want to reset the ink level counter. Click **Old Color Cartridge** to return the cartridge carrier to the far right position.
- 11** Test the print cartridge by choosing the **Clean Print Nozzles** button on the Cartridges Tab.

If the print quality has not improved after this cleaning process, replace your print cartridge. If print quality still does not improve, your printer may require service.

Printing from DOS

Chapter Five

You must install the following before you can print from DOS applications:

- Lexmark 5700 Series printer software
- PCL 3 printer driver for each DOS application

Appropriate drivers in order of preference are:

- HP DeskJet 500C
- DeskJet 500

You must use the HP DeskJet 500C for color output. If your application does not include drivers for the HP DeskJet 500C or the DeskJet 500, contact the software manufacturer for a compatible driver replacement.

Changing print settings for DOS applications

If possible, use options in your DOS application to change printer settings. Use the steps below only if you want to change a printer setting that does not exist in your DOS application. Settings in your DOS application override settings in the driver.

To change DOS print settings from the printer software:

1 Open the printer's **Control Program**.

For help opening the Control Program, see “Opening the Control Program” on page 8.

2 Click the **DOS Printing Tab**.

3 Change settings as needed.

4 Click **OK** to save the settings.

Note: When you make changes on the DOS Printing Tab, they apply to DOS print jobs only. When you make changes on other tabs, they apply to all print jobs.

Printing from DOS applications

This section describes how to print from:

- DOS applications in Windows
- native DOS (non-Windows) applications.

DOS applications in Windows

Use these instructions only if your application runs from the DOS prompt in Windows. This section describes:

- printing from a DOS application
- printing from a DOS application to another printer
- printing to a file

Printing from a DOS application

When you print from a DOS application, your printer uses PCL 3 emulation. You must install a printer driver for PCL 3 emulation in each DOS application.

To print from DOS applications that run from the Windows DOS prompt:

- 1** Make sure you are in Windows, not native DOS.
- 2** Open the printer's **Control Program**.
For help opening the Control Program, see “Opening the Control Program” on page 8.
- 3** Click the **Options Tab**. From the Options tab make sure Disable CJ5700 DOS Printing (Enable DOS Printing to other Printers) is **not** checked.
- 4** Start your application from DOS.
For help, see your Windows documentation.
- 5** Install the HP DeskJet 500C as the current printer in the DOS application from which you are printing.
Some applications offer a color or black (mono) version of the HP DeskJet 500C driver. Choose the black (mono) version if you are printing in black only. Choose the color version if you are printing in color and black.
If your application does not offer the HP DeskJet 500C printer driver, install the DeskJet 500 printer driver. You will not be able to print in color with the DeskJet 500 printer driver.
For help installing a printer, see your application user's documentation.
- 6** You can use the printer driver for your Lexmark Photo Jetprinter™ 5770 to change printer settings that are not in your application. For help, see “Changing print settings for DOS applications” on page 35.
- 7** Print as you normally would from your application.

Note: When you make changes to the DOS Printing Tab, they apply to DOS print jobs only. When you make changes on other tabs, they apply to all print jobs.

Printing from a DOS application to another printer

Follow these steps when you want to send a DOS print job to a printer other than your Lexmark Photo Jetprinter 5770.

- 1 Open the printer's **Control Program**.
For help opening the Control Program, see “Opening the Control Program” on page 8.
- 2 From the **Options Tab**, select the **Disable CJ5700 DOS Printing** option.
- 3 If prompted, restart Windows.
- 4 Send a DOS print job to the other printer.

If you select Disable DOS Printing, you cannot print to your Lexmark Photo Jetprinter 5770 from a DOS application.

To print to your Lexmark Photo Jetprinter 5770, make sure this option is **not** selected. If prompted, restart Windows before sending a DOS print job to your Lexmark printer.

Printing to a file

To print a document that has been processed by the driver and stored in a file (that is, printed to file):

- 1 Make sure you are in Windows, not native DOS.
- 2 Start your application from DOS.
For help, see your Windows documentation.
- 3 Create a print file using the "Print to File" function of your application. For help printing to a file, see your application user's documentation.
- 4 Use this DOS command to copy the print file to the port where the printer is connected:

copy filename lptn /b

In the command example:

- **copy** is the DOS copy command.
- **filename** is the name of the print file you created.
- **lptn** is the port where your printer is connected. For example, **lpt1** or **lpt2**.
- **/b** instructs the computer to send the data in binary form.

Note: Avoid using the DOS **Print** command to send a job to the printer port. The Print command causes printing delays.

Printing from non-Windows DOS applications

Follow these steps if your application runs from the native DOS prompt, but does not run from the DOS prompt in Windows.

- 1** From Windows, open the printer's **Control Program**.
For help opening the Control Program, see “Opening the Control Program” on page 8.
- 2** Click the **Options Tab**.
- 3** Make sure **Disable CJ5700 DOS Printing (Enable DOS Printing to other Printers)** is **not** checked.
- 4** Exit Windows.
- 5** Start your DOS application.

- 6 Install the HP DeskJet 500C as the current printer in the DOS application from which you are printing.

Some applications offer a color or black (mono) version of the HP DeskJet 500C driver. Choose the black (mono) version if you are printing in black only. Choose the color version if you are printing in color and black.

If your application does not offer the HP DeskJet 500C printer driver, install the DeskJet 500 printer driver. You will not be able to print in color with the DeskJet 500 printer driver.

For help installing a printer, see your application user's documentation.

- 7 Create a print file using the "Print To File" function of your application. For help on printing to a file, see your application user's documentation.
- 8 Exit the DOS application.
- 9 Start Windows.
- 10 Double-click the MS-DOS icon in the Main group of Windows.
- 11 Use this DOS command to copy the print file to the port where the printer is connected:

copy filename lptn /b

In the command example:

- **copy** is the DOS copy command.
- **filename** is the name of the print file you created.
- **lptn** is the port where your printer is connected. For example, lpt1 or lpt2.
- **/b** instructs the computer to send the data in binary form.

Note: Avoid using the DOS **Print** command to send a job to the printer port. The Print command causes printing delays and may corrupt the print job.

Enabling DOS printing to other printers

To enable DOS printing to other printers:

- 1** Open the printer's **Control Program**.
For help opening the Control Program, see “Opening the Control Program” on page 8.
- 2** From the **Options Tab**, select the **Disable CJ5700 DOS Printing** option.
- 3** If prompted, restart Windows.

Enabling DOS printing to your printer

To enable DOS printing to your printer:

- 1** Open the printer's **Control Program**.
For help opening the Control Program, see “Opening the Control Program” on page 8.
- 2** From the **Options Tab**, make sure **Disable CJ5700 DOS Printing (Enable DOS Printing to other Printers)** is **not** checked.
- 3** If prompted, restart Windows.

Troubleshooting

Chapter Six

Use this section to identify and solve problems.

Section	Page
Bidirectional communications problems	44
Printhead failure	47
Deleting photo files	49
Error messages on your computer	50
Error messages on the printer operator panel	51
General printing problems	52
Paper feed problems	57
Poor print quality	59
Printer software problems	63
Removing the exit tray	64

Bidirectional communications problems

These events indicate bidirectional communications problems:

- A message displays on your computer screen indicating your printer cannot establish bidirectional communications with your computer.
- Print cartridge ink level indicators on the Status or Cartridges Tabs of the printer's Control Program are grayed out.
- Job progress information and printer paper feeding error messages (such as Paper Out) do not display on your computer screen.

Before proceeding, verify:

- The printer is able to send and receive data:
 - a** Unplug the printer power cord from the electrical outlet.
 - b** Make sure the parallel cable is securely attached to both the computer and the printer.
 - c** Plug the printer power cord into a properly grounded electrical outlet.
- If you have a switch box or other device connected to the computer's parallel port, make sure it supports bidirectional communication. You may need to disconnect your printer from the switch box or other device and connect the printer directly to your computer.

- Bidirectional communications is NOT disabled in your Lexmark printer software.
 - a From the printer's Control Program, click the Options Tab.

For help opening the Control Program, see “Opening the Control Program” on page 8.
 - b Make sure Disable Bidirectional Communications is **not** checked.

If you checked all of the items above, and still experience bidirectional communications problems, continue with “Solving bidirectional communications problems”.

Solving bidirectional communications problems

Bidirectional communications problems have two primary causes:

- You are using the wrong parallel cable.
- Your computer system is not configured for bidirectional communications.

Replacing the parallel cable

You must use an IEEE 1284-compliant parallel cable that supports bidirectional printing. Verify your printer cable meets these specifications. To purchase a Lexmark cable, see “Parallel cable” on page 65.

Computer configuration problems

If you have the correct parallel cable and bidirectional communications problems persist, you may have a computer configuration problem. The three configuration problems usually preventing or disrupting bidirectional communications are:

- Your computer does not support bidirectional communications.

- The parallel port on your computer is not configured for bidirectional communications.
- The IRQ (Interrupt Request) assigned to your printer is also assigned to another hardware device, such as a scanner or sound card. This situation is commonly called a "hardware configuration conflict."

Contact your computer manufacturer, or see the documentation that came with your computer to determine if your computer supports bidirectional communications.

With bidirectional communications problems you can use your printer, but the printer software will not function to its fullest capability. You can change printer settings, send print jobs to the printer, and change and align print cartridges. However, printer status and ink level information will not display on your computer screen.

On most computer systems, the parallel port configuration and IRQ assignments are changed from the computer's Configuration or Setup Utility. Check the documentation that came with your computer for information on the Configuration or Setup Utility.

Warning! If you are not familiar with configuring parallel ports or changing IRQ assignments, do not change these settings in the Setup or Configuration Utility. Contact your computer manufacturer or an experienced computer professional for assistance. Incorrect changes to your computer's configuration can cause serious problems.

Disabling bidirectional communications

If you cannot solve the bidirectional communication problem immediately, you can disable bidirectional communications. This does not solve the bidirectional communications problem but allows you to print jobs without an error message appearing.

Printhead failure

Any of these problems can cause the Printhead Failure message to appear:

- The print cartridge carrier contacts are dirty
- The print nozzles on the print cartridge are dirty
- There is a problem with the Color, Black, or Photo print cartridge

To begin troubleshooting the problem:

- 1** Clean the print cartridge carrier contacts and wipe the print cartridge print nozzles of **both** print cartridges.

For help, see “Cleaning print cartridge carrier contacts” on page 32 and “Wiping the print nozzles and contacts” on page 30.

- 2** Reinstall both print cartridges in the printer.

- 3** Print a test page.

- a** From the printer's Control Program, click the Status Tab.

For help opening the Control Program, see “Opening the Control Program” on page 8.

- b** Click Print Test Page.

- 4** Did the message reappear?
- **YES.** There may be a problem with one of the print cartridges. Continue with step 5.
 - **NO.** You have solved the problem.

5 Remove the Photo or Black print cartridge from the printer. For help, see “Removing a print cartridge” on page 22.

6 Print a test page.

Did the message reappear?

- **YES.** Go to step 7.
- **NO.** The problem is with the Photo or Black print cartridge. Do not go to step 7. Continue with “Replacing the print cartridge” on page 49.

7 Reinstall the Photo or Black print cartridge. For help, see “Installing or changing a print cartridge” on page 24.

8 Remove the Color print cartridge.

9 Print a test page.

Did the message reappear?

- **YES.** Go to step 10.
- **NO.** The problem is with the Color print cartridge. Do not go to step 10. Continue with “Replacing the print cartridge” on page 49.

10 Your printer requires service. See your printer registration card for the appropriate telephone number for your country.

Replacing the print cartridge

- 1 Replace the print cartridge that has the problem with a new print cartridge. For help, see “Installing or replacing print cartridges” on page 22.
- 2 Print a test page.

Did the message reappear?

- **YES.** Your printer requires service. See your printer registration card for the appropriate telephone number for your country.
- **NO.** You have solved the problem.

Deleting photo files

If your camera card is full, you can make room for more photo files by using your camera to delete any unwanted files. If you use Windows Explorer to delete the files from your camera card, you must empty the Recycle Bin before you remove the camera card from the printer.

Error messages on your computer

Message	Solutions
Ink low	Your print cartridge is running out of ink. You need to purchase a new print cartridge.
Out of memory	<ul style="list-style-type: none">• Before sending a file to print, close all other open files in the application you are using. The printer prints a blank page when too many files are open in the same application.• Free memory by closing other open applications.• Decrease the print quality of your print job.• Consider purchasing more memory for your personal computer.
Out of paper	<p>You may have the wrong paper source selected in the printer software.</p> <p>If an Out of Paper message appears and you are using a non-bidirectional printer cable, follow the steps below to continue printing:</p> <ol style="list-style-type: none">1 Load paper.2 Resend your print job. <p>Your printer software will not function properly unless you use an IEEE 1284-compliant parallel cable with your printer.</p>
Paper jam	<ol style="list-style-type: none">1 Pull firmly on the paper to remove it. If you cannot reach the paper because it is too far into the printer, open the printer front cover and pull the paper out from the front of the printer.2 Close the printer front cover.3 Resend your print job. Start with the page on which the paper jam occurred.
Printhead failure	See “Printhead failure” on page 47.

Error messages on the printer operator panel

Message	Solutions
Please insert Camera Card	Make sure a camera card is properly inserted in the printer. Refer to page 11 of your <i>Getting Started</i> booklet that tells you how to use your printer without a computer.
Cannot read Camera Card or SELECT PHOTOS photo=0	The printer cannot read the camera card or the image file on your camera card is not supported. Remove and re-insert the camera card in the printer. If the error message still displays, remove the camera card and check it with the display on your digital camera. The camera card may be blank or defective.
Please Load Paper	Make sure: <ul style="list-style-type: none">• the printer has paper.• the paper is properly loaded.
Please install photo cartridge	You need to install a Photo cartridge. Refer to page 4 of your <i>Getting Started</i> booklet that tells you how to use your printer without a computer.
Please insert storage disk	Insert the storage disk into the optional external storage drive. See page 26 of your <i>Getting Started</i> booklet that tells you how to use your printer without a computer.

General printing problems

Problems	Solutions
Colors on printout differ from colors on screen	<p>To more closely match the colors on your printouts with the colors on your screen, select Natural Color as the Document Type.</p> <p>To select Natural Color as the Document Type:</p> <ol style="list-style-type: none">1 Open the application's File menu.2 Choose Print (or Printer) Setup.3 In the Printer Setup dialog box, click the Properties, Options, or Setup button (depending on the application). The Lexmark 5700 dialog box appears.4 Click the Document/Quality Tab.5 Make sure Natural Color is selected.
DOS print file takes too long to print	<p>If you are attempting to print a DOS file by sending it to the port to which the printer is connected, use the DOS Copy command. Avoid using the DOS Print command. The DOS Print command causes printing delays.</p>
Power supply fails	<p>If your power supply fails, replace it with the Lexmark replacement part or other UL LISTED Direct Plug-In Power Unit marked "Class 2" and rated 30 V dc at 500 mA.</p>

Problems	Solutions
<p>DOS print job does not print</p>	<p>Check the following items:</p> <ol style="list-style-type: none"> 1 From the printer's Control Program, click the Options Tab. 2 Make sure Disable CJ5700 DOS Printing is not checked. <ul style="list-style-type: none"> • Make sure Spool MS-DOS print jobs is selected: <ol style="list-style-type: none"> 1 Open the Printer Driver Properties folder: <ol style="list-style-type: none"> a In the Windows Printer Folder, right-click the Lexmark 5700 Series icon. b In the sidebar menu, click Properties. c Choose the Details Tab. 2 Click the Port Settings button. 3 Make sure Spool MS-DOS print jobs is checked. 4 Click OK. • If you send a second DOS print job before the first DOS print job has finished processing, neither job will print. Normally, a job is finished processing when the first page of the job prints. • Also, make sure the Lexmark 5700 Series is set as your default printer driver.
<p>Intermittent printing</p>	<p>See "Bidirectional communications problems" on page 44.</p>
<p>Old document prints with different fonts</p>	<p>When you print a document formatted for a different printer, Windows may substitute different fonts. Line breaks and page breaks may change also. Use the software application that created the document to fix these problems, then save your changes for the next time you print.</p>
<p>Parallel cable interface problems</p>	<p>See "Bidirectional communications problems" on page 44.</p>

Problems	Solutions
<p>Paper Status light is blinking and an error message appears on your screen</p>	<p>If the Paper Status light is blinking and an error message appears on your computer screen, make sure:</p> <ul style="list-style-type: none"> • the printer has paper. • there is not a paper jam. <p>If the printer has paper and there is no paper jam, try the following:</p> <ol style="list-style-type: none"> 1 Unplug the printer power cord from the electrical outlet. 2 Remove any paper fragments or objects from the printer. 3 Plug the printer power cord into an electrical outlet. <p>If the light continues to blink, the printer may need service.</p> <p>If your printer needs service, refer to your printer registration card or warranty/service information for the appropriate telephone number for your country.</p>
<p>Printer has missing or damaged parts</p>	<p>If your printer has missing or damaged parts, contact your point of purchase.</p>
<p>Printer pauses frequently during a print job</p>	<p>If your printer pauses frequently (every two or three lines) during a print job, and the printed pages have alternating bands of light and dark print, select Enable Buffer Mode from the Options Tab.</p> <ol style="list-style-type: none"> 1 From the printer's Control Program, click the Options Tab. 2 Make sure the Enable Buffer Mode option is checked.

Problems	Solutions
<p>Printer is plugged in but nothing prints (There is no action from the printer)</p>	<p>Make sure:</p> <ul style="list-style-type: none"> • the printer has paper. • you have paper in the correct feeder. • the printer parallel cable is completely plugged into the printer. • the printer is not being held or paused. To check the printer status: <ol style="list-style-type: none"> 1 From the Printers folder, double-click the Lexmark 5700 Series icon. 2 Click the Printer menu and make sure no checkmark appears next to the Pause Printing option. • Print a printer test page. If the test page prints, the printer is functioning properly. Check your application. • If you are trying to print from a DOS-based application, the problem could be with your DOS settings. Check your DOS printer port settings, driver, and your application settings.
<p>Printer prints very slowly</p>	<p>Try the following if your printer is printing slowly:</p> <ul style="list-style-type: none"> • Decrease the print quality. • If you are printing a text document, make sure you are using a Black print cartridge and not a Photo cartridge. • If you are printing a text-only document, change the Halftone method from Air Brush to Fine Dither Pattern or Line Art Pattern. The Air Brush setting improves the appearance of graphics but slows the print time. • Consider purchasing more memory for your personal computer. • Check the document you are printing. If you are using several graphics, it may take longer to print than regular text.

Problems	Solutions
<p>Printer seems to be printing but no characters appear</p>	<p>Make sure:</p> <ul style="list-style-type: none"> • The print cartridges are properly installed in the printer. See “Installing or replacing print cartridges” on page 22. • The tape was removed from the print cartridges before they were installed. • The printer has paper.
<p>Test page does not print</p>	<p>Make sure:</p> <ul style="list-style-type: none"> • The parallel cable is properly connected to the computer and printer. For help, refer to the printer's setup sheet. • Paper is loaded in the printer correctly. For help, see “Loading paper and other media” on page 9. • Print cartridges are installed correctly. For help, see “Installing or replacing print cartridges” on page 22. <p>If these suggestions do not solve the problem, your printer may need service. Refer to your printer registration card or warranty/service information for the appropriate telephone number for your country.</p>

Paper feed problems

Problems	Solutions
Paper fails to feed	<p>If paper doesn't move through the automatic feeder:</p> <ol style="list-style-type: none">1 Open the printer front cover.2 Remove any obstructions inside the printer.3 Close the printer front cover.4 Press the Paper Feed button.
Paper jam	<ol style="list-style-type: none">1 Pull firmly on the paper to remove it. If you cannot reach the paper because it is too far into the printer, open the printer front cover and pull the paper out from the front of the printer.2 Close the printer front cover.3 Resend your print job. Start with the page on which the paper jam occurred.
Paper skews or buckles	<p>If paper skews or buckles while moving through the printer, make sure:</p> <ul style="list-style-type: none">• You do not force the paper down into the printer when you load it.• There is not too much paper in the automatic feeder. Depending on the thickness of your paper, the automatic feeder can hold up to 100 sheets of paper.• The left paper guide does not cause the paper to bow in the automatic feeder.• You are using the correct type of paper.• The left paper guide is against the side of the paper.• The printer is on a flat, level surface.

Problems	Solutions
<p>Paper sticks together</p>	<p>If paper sticks together when moving through the automatic feeder, try the following:</p> <ul style="list-style-type: none"> • Make sure there is not too much paper in the automatic feeder. Depending on the thickness of your paper, the automatic feeder can hold up to 100 sheets of paper. • Make sure you are using the correct type of paper. • Remove paper from the automatic feeder and flex or fan the paper. • When loading paper, do not force the paper down into the printer. <p>Note: Humid conditions may cause some papers to stick together.</p>
<p>Transparencies, glossy film, or photo papers stick together</p>	<p>If transparencies, glossy film, or photo papers stick together after they exit the printer:</p> <ul style="list-style-type: none"> • Use a transparency, glossy film, or photo paper designed for an inkjet printer. • Remove each transparency, glossy film, or photo paper as it exits from the printer.

Poor print quality

Problems	Solutions
Black text is not sharp	Your printer was shipped with a Color print cartridge and a Photo print cartridge. For better text and graphics printing, we recommend replacing the Photo print cartridge with a Black print cartridge (P/N 12A1970). Make sure a Black print cartridge is installed and not a Photo print cartridge.
Characters not aligned correctly at left margin	Try the following suggestions to correct this problem: <ul style="list-style-type: none">• Make sure you do not have hard-coded (extra) spaces at the left margin.• Clean the print cartridge nozzles. See “Cleaning the print nozzles” on page 29.• Align the print cartridges. See “Aligning the print cartridges” on page 27.• If you aligned the print cartridges from the printer operator panel, but are now using the printer connected to a computer, you need to realign the print cartridges from the computer using the printer’s Control Program software.
Characters with white lines	Try one (or more) of the following suggestions to correct this problem: <ul style="list-style-type: none">• A print cartridge may be out of ink or low on ink. If the Ink Low message appears on your screen, install a new print cartridge. To view the ink level, check the print cartridge image shown in the Cartridge Tab.• Remove and reinstall one of the print cartridges. See “Installing or replacing print cartridges” on page 22.• Clean the print cartridge nozzles. See “Cleaning the print nozzles” on page 29.• If you are printing transparencies, try changing the fill pattern in your application software.

Problems	Solutions
<p>General print quality problems</p>	<p>Try one (or more) of the following suggestions to correct this problem:</p> <ul style="list-style-type: none"> • A print cartridge may be out of ink or low on ink. If the Ink Low message has appeared on your screen, install a new print cartridge. See “Installing or replacing print cartridges” on page 22. To view the ink level, check the ink level graphic shown on the Cartridges Tab or the Status Tab of the Control Program. • Change the Print Quality setting to something other than Quick Print 600. • Clean the print cartridge nozzles. See “Cleaning the print nozzles” on page 29. • Make sure the print cartridges are installed correctly. See “Installing or replacing print cartridges” on page 22. • Make sure you are using the correct type of paper. • Adjust the Brightness and Contrast.
<p>Improperly formed or misaligned characters</p>	<p>Clean the print cartridge nozzles. See “Cleaning the print nozzles” on page 29.</p>
<p>Poor print quality at left, right, or bottom edge of page</p>	<p>Like other printers, your printer cannot print in the extreme left, right, or bottom edges of a page. To avoid poor print quality at the edges of the page, we recommend using these minimum margin settings:</p> <p>Left and Right Margins</p> <p>Left and right margin settings must be at least 6.35 mm (0.25 in.) each for all paper sizes except A4. For A4 size paper, left and right margin settings must be at least 3.37 mm (0.133 in.) each.</p> <p>Top and Bottom Margins</p> <p>The top margin must be set to at least 1.7 mm (0.067 in.).</p> <p>The bottom margin setting for all paper sizes must be 12.7 mm (0.5 in.) for monochrome printing and 19.5 mm (0.75 in.) for color printing.</p>

Problems	Solutions
<p>Poor print quality at left, right, or bottom edge of envelope</p>	<p>Like other printers, your printer cannot print in the extreme left, right, or bottom edges of an envelope. To avoid poor print quality at the edges of the envelope, we recommend using these minimum margin settings:</p> <p>Left and Right Margins</p> <p>Left and right margin settings must be at least 6.35 mm (0.25 in.) each for all envelope sizes.</p> <p>Top and Bottom Margins</p> <p>The top margin must be set to at least 1.7 mm (0.067 in.)</p> <p>The bottom margin setting for all envelope sizes must be 12.7 mm (0.5 in.).</p>
<p>Print is too dark or smudged</p>	<p>Try the following suggestions to correct this problem:</p> <ul style="list-style-type: none"> • Increase the Brightness setting. • Make sure the Paper Type setting in the printer software matches the Paper type loaded in the printer. • Make sure the paper is straight and unwrinkled. • Let the ink dry before handling the paper. • Change Print Quality to Quick Print 600. • Clean the print cartridge nozzles. See “Cleaning the print nozzles” on page 29.
<p>Photo is too dark or smudged</p>	<p>Try the following suggestions to correct this problem:</p> <ul style="list-style-type: none"> • Make sure the Photo cartridge is installed. • Adjust the printer software settings. • We recommend using a coated paper or photo paper for the best print results.

Problems	Solutions
<p>Print smears on the page</p>	<p>Print smearing may occur in two ways:</p> <ul style="list-style-type: none"> • Print is smeared as the printer prints the page. • A page prints without smearing, but is smeared by damp ink on the next page exiting the printer. <p>Try the following suggestions to prevent print smearing:</p> <ul style="list-style-type: none"> • Print is smeared as the printer prints the page. <ul style="list-style-type: none"> • Change to a higher or lower Print Quality setting. • Disable your Windows screen saver. See your Windows documentation. • Page is smeared by the next page exiting the printer. <p>The ink may still be damp when a page finishes printing. Remove the pages as they exit the printer and allow them to dry before stacking.</p>
<p>Printed pages have alternating bands of light and dark print</p>	<p>See “Printer pauses frequently during a print job” on page 54.</p>
<p>Solid black areas on transparencies contain white streaks</p>	<p>Try using a different fill pattern in your application software.</p>
<p>Unexpected or missing characters</p>	<p>Make sure you have your Lexmark 5700 Series printer driver selected as the default printer.</p> <p>Your printer may have bidirectional communications problems. See “Bidirectional communications problems” on page 44.</p>
<p>Vertical straight lines are not smooth</p>	<p>Try the following suggestions to improve print quality of vertical straight lines in tables, borders, and graphs:</p> <ul style="list-style-type: none"> • Clean the print cartridge nozzles. See “Cleaning the print nozzles” on page 29. • Test the printhead alignment. See “Aligning the print cartridges” on page 27. • Change Print Quality to something other than Quick Print 600.

Printer software problems

Problems	Solutions
Portions of printer's Control Program grayed out	If the ink level indicators of the Cartridges Tab are grayed out, and printer error messages and job progress information do not appear on the computer screen, see “Bidirectional communications problems” on page 44.
Printer software settings are not in effect	<p>If the printer settings you choose in the printer software are not in effect, check the settings in the software application you are using.</p> <p>Printer settings in your application may override settings in the printer software. Make all printer setting changes in your application if possible. Use the printer driver to change a setting only if your application does not have that setting.</p>

Removing the exit tray

If you need to repack the printer in its original box, you must remove the paper exit tray.

- 1 Remove the paper support.
- 2 Pull the paper exit tray as far out of the printer as possible.
- 3 Turn the printer over so you can see the bottom of the printer.
- 4 Locate the hooks holding the paper exit tray in place.
- 5 Using a ball-point pen, **gently** pry the hooks upward until you can pull the exit tray past them.

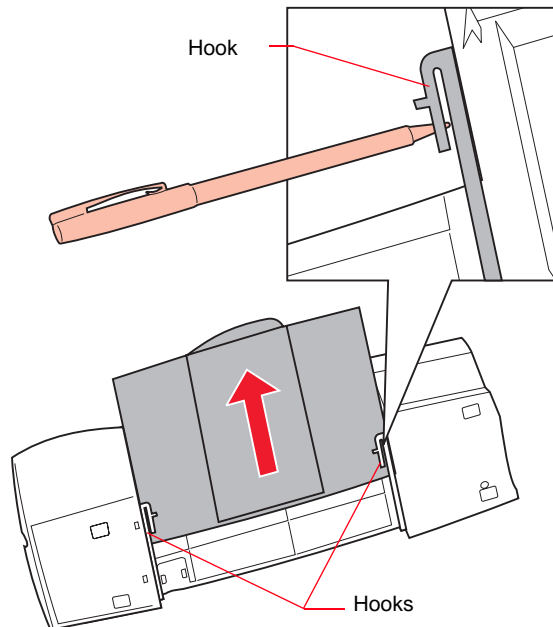

- 6 Pull the paper exit tray all the way out of the printer.

Ordering Supplies

Chapter Seven

To order Lexmark supplies, either contact your point of purchase or any Lexmark Authorized Supplies Dealer.

You may also order supplies from Lexmark over the telephone. Check your printer registration card for the appropriate telephone number for each country.

Print cartridges

To order print cartridges from Lexmark, use these part numbers:

Cartridge type:	Part number:
Photo	12A1990
Color	12A1980
Black	12A1970

Parallel cable

To order an IEEE 1284-compatible parallel cable, use Lexmark part number 1329605.

Photo paper

To order Inkjet Photo Paper from Lexmark, use these part numbers:

Size	Number of sheets	Part number
4x6	20	12A0074
Letter	20	1372481
A4	20	1372208

Coated paper

For the best color and black and white printing results, use a coated paper such as Lexmark's High Resolution Premium Inkjet paper. To order this paper from Lexmark, use these part numbers:

Size	Number of sheets	Part number
Letter	100	1402780
A4	100	1402781

Glossy film

To print on glossy film, use Lexmark Inkjet Glossy Film. To order glossy film from Lexmark, use these part numbers:

Size	Number of sheets	Part number
Letter	10	1402795
Letter	50	1402750
A4	10	1402796
A4	50	1372361

Transparencies

To print on transparencies, use Lexmark Inkjet Transparencies. To order these transparencies from Lexmark, use these part numbers:

Size	Number of sheets	Part number
Letter	20	1402797
A4	20	1402798

Greeting cards with envelopes

Each greeting card comes with an envelope. To order Inkjet Greeting Cards from Lexmark, use these part numbers:

Size	Number of sheets	Part number
Letter	20	1372482
A4	20	70X7254

Labels

To order Inkjet Labels from Lexmark, use these part numbers:

Sheet size	Label size	Labels per sheet	Number of sheets	Part number
Letter	1 x 2-5/8 in.	30	20	70X7250
Letter	2 x 4 in.	10	20	70X7251
A4	63.5 x 38.1 mm	21	20	70X7252
A4	99.1 x 67.7 mm	8	20	70X7253

Iron-on transfers for T-shirts

To order Inkjet Iron-On Transfers, use these part numbers:

Size	Number of sheets	Part number
Letter	10	1372480
A4	10	1402519

Notices

Appendix A

References in this publication to products, programs, or services do not imply that the manufacturer intends to make these available in all countries in which it operates. Any reference to a product, program, or service is not intended to state or imply that only that product, program, or service may be used. Any functionally equivalent product, program, or service that does not infringe any existing intellectual property right may be used instead. Evaluation and verification of operation in conjunction with other products, programs, or services, except those expressly designated by the manufacturer, are the user's responsibility.

Energy Star



effort with computer manufacturers to

The EPA
ENERGY
STAR
Computers
program is a
partnership

promote the introduction of energy-efficient products and to reduce air pollution caused by power generation.

Companies participating in this program introduce personal computers, printers, monitors, or fax machines that power down when they are not being used. This feature will cut the energy used by up to 50 percent. Lexmark is proud to be a participant in this program.

As an Energy Star Partner, Lexmark International, Inc. has determined that this product meets the Energy Star guidelines for energy efficiency.

Electronic Emission Notices

Federal Communications Commission (FCC) Compliance Information Statement

The Lexmark Photo Jetprinter 5770, Type 4093-S04, has been tested and found to comply with the limits for a Class B digital device, pursuant to Part 15 of the FCC Rules. Operation is subject to the following two conditions: (1) this device may not cause harmful interference, and (2) this device must accept any interference received, including interference that may cause undesired operation.

The FCC Class B limits are designed to provide reasonable protection against harmful interference in a residential installation. This equipment generates, uses and can radiate radio frequency energy and, if not installed and used in accordance with the instructions, may cause harmful interference to radio communications. However, there is no guarantee that interference will not occur in a particular installation. If this equipment does cause harmful interference to radio or television reception, which can be determined by turning the equipment off and on,

the user is encouraged to try to correct the interference by one or more of the following measures:

- Reorient or relocate the receiving antenna.
- Increase the separation between the equipment and receiver.
- Connect the equipment into an outlet on a circuit different from that to which the receiver is connected.
- Consult your point of purchase or service representative for additional suggestions.

The manufacturer is not responsible for any radio or television interference caused by using other than recommended cables or by unauthorized changes or modifications to this equipment. Unauthorized changes or modifications could void the user's authority to operate this equipment.

Note: To assure compliance with FCC regulations on electromagnetic interference for a Class B computing device, use a properly shielded and grounded cable such as Lexmark part number 1329605. Use of a substitute cable not properly shielded and grounded may result in a violation of FCC regulations.

Any questions regarding this compliance information statement should be directed to:

Director of Lab Operations
Lexmark International, Inc.
740 New Circle Road NW
Lexington, KY 40550
(606) 232-3000

Industry Canada Compliance Statement

This Class B digital apparatus meets all requirements of the Canadian Interference-Causing Equipment Regulations.

Avis de conformité aux normes d'Industrie Canada

Cet appareil numérique de la classe B respecte toutes les exigences du Règlement sur le matériel brouilleur du Canada.

European Community (EC) Directives Conformity

This product is in conformity with the protection requirements of EC Council directives 89/336/EEC and 73/23/EEC on the approximation and harmonization of the laws of the Member States relating to electromagnetic compatibility and safety of electrical equipment designed for use within certain voltage limits.

A declaration of conformity with the requirements of the Directive has been signed by the Director of Manufacturing and Technical Support, Lexmark International, S.A., Boigny, France.

This product satisfies the Class B limits of EN 55022 and safety requirements of EN 60950.

Japanese VCCI Notice

この装置は、情報処理装置等電波障害自主規制協議会（VCCI）の基準に基づくクラスB情報技術装置です。この装置は、家庭環境で使用することを目的としていますが、この装置がラジオやテレビジョン受信機に直接して使用されると、受信障害を引き起こすことがあります。
取扱説明書に従って正しい取り扱いをして下さい。

The United Kingdom Telecommunications Act 1984

This apparatus is approved under the approval number NS/G/1234/J/100003 for the indirect connections to the public telecommunications systems in the United Kingdom.

Safety information

- If your product is NOT marked with this symbol , it MUST be connected to an electrical outlet that is properly grounded.
- The power cord must be connected to an electrical outlet that is near the product and easily accessible.
- Refer service or repairs, other than those described in the operating

instructions, to a professional service person.

- This product is designed, tested and approved to meet strict global safety standards with the use of specific Lexmark components. The safety features of some parts may not always be obvious. Lexmark is not responsible for the use of other replacement parts.

Consignes de sécurité

- Si le symbole  n'apparaît pas sur votre produit, ce dernier DOIT être branché sur une prise de courant mise à la terre.
- Le câble d'alimentation doit être connecté à une prise de courant placée près du produit et facilement accessible.
- L'entretien et les réparations autres que ceux décrits dans les instructions d'emploi doivent être effectués par le personnel de maintenance qualifié.
- Ce produit a été conçu, testé et approuvé pour respecter les normes strictes de sécurité globale lors de l'utilisation de composants Lexmark spécifiques. Les caractéristiques de sécurité de certains éléments ne sont pas toujours évidentes. Lexmark ne peut être tenu responsable de l'utilisation d'autres pièces de rechange.

Norme di sicurezza

- Se il prodotto non è contrassegnato con questo simbolo  deve

essere collegato lo stesso ad una presa elettrica con messa a terra.

- Il cavo di alimentazione deve essere collegato ad una presa elettrica posta nelle vicinanze del prodotto e facilmente raggiungibile.
- Per la manutenzione o le riparazioni, escluse quelle descritte nelle istruzioni operative, consultare il personale di assistenza autorizzato.
- Il prodotto è stato progettato, testato e approvato in conformità a severi standard di sicurezza e per l'utilizzo con componenti Lexmark specifici. Le caratteristiche di sicurezza di alcune parti non sempre sono di immediata comprensione. Lexmark non è responsabile per l'utilizzo di parti di ricambio di altri produttori.

Sicherheitshinweise

- Falls der Drucker nicht mit diesem Symbol  markiert ist, muß er an eine ordnungsgemäß geerdete Steckdose angeschlossen werden.
- Das Netzkabel muß an eine Steckdose angeschlossen werden, die sich in der Nähe des Geräts befindet und leicht zugänglich ist.
- Wartungsarbeiten und Reparaturen, mit Ausnahme der in der Betriebsanleitung näher beschriebenen, sollten Fachleuten überlassen werden.
- Dieses Produkt und die zugehörigen Komponenten wurden entworfen und getestet,

um beim Einsatz die weltweit gültigen Sicherheitsanforderungen zu erfüllen. Die sicherheitsrelevanten Funktionen der Bauteile und Optionen sind nicht immer offensichtlich. Sofern Teile eingesetzt werden, die nicht von Lexmark sind, wird von Lexmark keinerlei Verantwortung oder Haftung für dieses Produkt übernommen.

Pautas de Seguridad

- Si su producto no tiene este símbolo, , es IMPRESCINDIBLE conectarlo a una toma de corriente eléctrica con toma de tierra correcta.
- El cable de alimentación deberá conectarse a una toma de corriente situada cerca del producto y de fácil acceso.
- Cualquier servicio o reparación deberá realizarse por parte del personal cualificado, a menos que se trate de las averías descritas en las instrucciones de utilización.
- Este producto se ha diseñado, verificado y aprobado para cumplir los más estrictos estándares de seguridad global usando los componentes específicos de Lexmark. Puede que las características de seguridad de algunas piezas no sean siempre evidentes. Lexmark no se hace responsable del uso de otras piezas de recambio.

Veiligheidsvoorschriften

- Zorg ervoor dat uw product is aangesloten op een geaard

stopcontact als het product niet is gemarkeerd met het symbool .

- Het netsnoer moet worden aangesloten op een gemakkelijk bereikbaar stopcontact in de buurt van het product.
- Neem contact op met een professionele onderhoudstechnicus voor onderhoud en reparaties die niet in de bij het product geleverde instructies beschreven worden.
- Dit product is ontworpen, getest en goedgekeurd om te voldoen aan strenge internationale veiligheidsvoorschriften. De veiligheidsvoorzieningen van bepaalde onderdelen zullen niet altijd duidelijk zichtbaar zijn. Lexmark is niet verantwoordelijk voor het gebruik van andere vervangende onderdelen.

Sikkerhedsoplysninger

- Hvis dit produkt ikke er markeret med dette symbol , skal det sluttes til en stikkontakt med jordforbindelse.
- Ledningen skal sluttes til en stikkontakt, der er tæt på produktet og som er let tilgængelig.
- Service og reparationer, som ikke er beskrevet i brugsanvisningen, skal udføres af en kvalificeret tekniker.
- Dette produkt er udviklet, testet og godkendt i overensstemmelse med Lexmarks verdensomspændende standarder for sikkerhed. Delenes sikkerhedsfunktioner kan være skjulte. Lexmark påtager sig intet

ansvar for brugen af uoriginale reservedele.

Sikkerhedsinformasjon

- Hvis produktet ditt ikke er merket med dette symbolet,  , må det bare kobles til en stikkontakt som er jordat.
- Ledningen må være koblet til en stikkontakt nær produktet. Stikkontakten må være lett tilgjengelig.
- La bare kvalifisert personale ta seg av service og reparasjon som ikke er direkte beskrevet i bruksanvisningen.
- Dette produktet er utviklet, testet og godkjent i overensstemmelse med strenge verdensomspennende sikkerhetsstandarder for bestemte Lexmark-deler. Delenes sikkerhetsfunksjoner kan være skjulte. Lexmark er ikke ansvarlig for bruk av uoriginale reservedeler.

Säkerhetsanvisningar

- Om produkten INTE är märkt med denna symbol  MÅSTE den anslutas till ett jordat vägguttag.
- Nätkabeln måste anslutas till ett lättåtkomligt vägguttag i närheten av maskinen.
- Låt endast utbildad servicepersonal utföra sådan service och sådana reparationer som inte beskrivs i handledningen.
- Denna produkt är utformad, testad och godkänd för att uppfylla internationella säkerhetsbestämmelser när den

används tillsammans med andra Lexmark-produkter.

Säkerhetsegenskaperna för vissa delar är inte helt uppenbara.

Lexmark frånsäger sig ansvaret om delar av ett annat fabrikat används.

Informació de Seguretat

- Si el vostre producte no està marcat amb el símbol  , S'HAURÀ de connectar a una presa elèctrica de terra.
- El cable de potència s'haurà de connectar a una presa de corrent propera al producte i fàcilment accessible.
- Si heu de fer una reparació que no figuri entre les descrites a les instruccions de funcionament, confieu-la a un professional.
- Aquest producte està dissenyat, comprovat i aprovat per tal d'acomplir les estrictes normes de seguretat globals amb la utililització de components específics de Lexmark. Les característiques de seguretat d'algunes peces pot ser que no sempre siguin òbvies. Lexmark no es responsabilitza de l'us d'altres peces de recanvi.

Turvaohjeet

- Jos tuotteessa ei ole tätä tunnusta,  , sen saa kytkeä vain maadoitettuun pistorasiaan.
- Tuotteen verkkojohto on kytkettävä sitä lähellä olevaan pistorasiaan. Varmista, että kulku pistorasian luo on esteetön.

- Muut kuin käyttöohjeissa mainitut huolto- tai korjaustoimet on jätettävä huoltoedustajalle.
- Tämä tuote on testattu ja hyväksytty. Se täyttää korkeat maailmanlaajuiset turvallisuusvaatimukset, kun siinä käytetään tiettyjä Lexmarkin valmistusosia. Joidenkin osien turvallisuusominaisuudet eivät aina ole itsestään selviä. Lexmark ei vastaa muiden kuin alkuperäisten osien käytöstä.

Informações de Segurança

- Se o produto NÃO estiver marcado com este símbolo,  necessário ligá-lo a uma tomada com ligação à terra.
- O cabo deve ser ligado a uma tomada localizada perto do produto e facilmente acessível.
- Para todos os serviços ou reparações não referidos nas instruções de operação, deve contactar um técnico dos serviços de assistência.
- Este produto foi concebido, testado e aprovado para satisfazer os padrões globais de segurança na utilização de componentes específicos da Lexmark. As funções de segurança de alguns dos componentes podem não ser sempre óbvias. A Lexmark não é responsável pela utilização de outros componentes de substituição.

Informações de Segurança

- Se o produto não estiver marcado com este símbolo, , ele DEVE SER conectado a uma tomada elétrica com ligação à terra.
- O cabo de alimentação deve ser conectado a uma tomada elétrica localizada perto do produto e de fácil acesso.
- Para todos os serviços ou reparações não descritos nas instruções de operação, entre em contato com um técnico dos serviços de assistência.
- Este produto está projetado, testado e aprovado para satisfazer os padrões globais de segurança para uso de componentes específicos da Lexmark. Os recursos de segurança de alguns componentes podem não ser sempre óbvios. A Lexmark não é responsável pelo uso de outros componentes de substituição.

Информация по технике безопасности

- Если приобретенное Вами изделие НЕ имеет маркировки , то его НЕОБХОДИМО подключать к надежно заземленной розетке.
- Кабель питания следует подключать к легкодоступной электрической розетке, расположенной вблизи от места установки изделия.
- Операции по обслуживанию и ремонту, за исключением описанных в настоящем Руководстве, должны выполняться специально обученным персоналом.
- Данное изделие спроектировано, испытано и прошло аттестацию на соответствии жестким глобальным стандартам безопасности в расчете на использование определенных частей производства фирмы Lexmark. Влияние отдельных деталей на безопасность не всегда очевидно. Фирма Lexmark не несет ответственности за использование запасных частей, отличных от рекомендованных.

Przepisy bezpieczeństwa

Jeżeli produkt NIE jest oznaczony symbolem , może być podłączony TYLKO do prawidłowo uziemionego gniazda elektrycznego.

Kabel zasilający musi być podłączony do łatwo dostępnego gniazda elektrycznego, znajdującego się w pobliżu urządzenia.

Wszelkie naprawy i czynności serwisowe, oprócz opisanych w instrukcji obsługi, powinny być wykonywane przez autoryzowany serwis.

Produkt został zaprojektowany z wykorzystaniem określonych podzespołów firmy Lexmark i zatwierdzony jako spełniający światowe standardy bezpieczeństwa. Pozostałe podzespoły mogą nie spełniać tych warunków. Firma Lexmark nie ponosi odpowiedzialności za skutki używania innych części zamiennych.

Güvenlik Bilgisi

- Ürünüzdə  simgesi YOKSA, ürün doğru biçimde topraklanmış bir elektrik prizine TAKILMALIDIR.
- Güç kablosu, ürünün yakınında ve kolay ulaşılabilir bir elektrik prizine takılmalıdır.
- İşletim yönergelerinde açıklananlar dışında servis veya onarım için yetkili servis personeline başvurun.
- Bu ürün, özel Lexmark bileşenlerinin kullanımı konusundaki genel güvenlik standartlarına uyacak biçimde tasarlanmış, denenmiş ve onaylanmıştır. Bazı parçaların güvenlik özellikleri her zaman kesin olmaz. Lexmark, başka yedek parçaların kullanımından sorumluluk taşımaz.

安全のためのご案内

- ご使用の製品にこの  記号がついていない場合は、正しく接地（アース）してある電源コンセントに接続する必要があります。
- 電源コンセントは、接続の邪魔となるような物が近い近くの電源コンセントに接続してください。
- 整備・修理が必要な場合、使用説明書にその旨の記載がある場合を除いて、専門の技術者にご連絡ください。
- 当製品は、特定の Lexmark 部品に関するきびしい包括的安全基準に適合するように、設計、試験され、承認されています。部品には、安全機能が必ずしも明白でないものもあります。Lexmark は、他の交換部品の使用は保証できません。

安全资讯

- 如果您的产品没有  符号，所接的电源插座一定要有适当的接地处理。
- 电线接线的插座与产品的距离不可太远，并且要合乎使用方便的原理。
- 有关维护或修理方面的细节，除了参考操作说明以外，还可联络专业服务人员。
- 本产品使用特有的 Lexmark 元件，并依照严格的世界安全标准来设计、测试及验证。有些零件的安全功能可能不明显。对于其他厂牌更换零件的使用，Lexmark 概不负责。

안전 사항

- 제품에  심볼이 표시되어 있지 않은 경우 제품을 적절히 접지되어 있는 전기 콘센트에 연결하여야 합니다.
- 전원 코드는 제품 가까이에 있고 쉽게 접근할 수 있는 콘센트에 연결하십시오.
- 운영 지침서에 기술되어 있지 않은 서비스나 수리는 전문 서비스 기술자에게 의뢰하십시오.
- 본 제품은 특정 Lexmark 구성 요소의 사용에 있어 엄격한 세계 안전 표준에 맞도록 설계, 테스트되었으며 승인받았습니다. 일부 부품의 안전성은 항상 보장되지 않습니다. Lexmark는 다른 교체 부품의 사용에 대한 책임을 지지 않습니다.

Statement of Limited Warranty

Appendix B

Lexmark International, Inc., Lexington, KY

This warranty applies to the United States and Canada. For customers outside the U.S. and Canada, refer to the country-specific warranty information that came with your printer.

Lexmark Photo Jetprinter 5770

This Statement of Limited Warranty applies to this product if it was originally purchased for your use, and not for resale, from Lexmark or a Lexmark remarketer, referred to in this statement as "Remarketer."

Warranty

Lexmark warrants that this product:

- Is manufactured from new parts, or new and serviceable used parts, which perform like new parts,
- Is free from defects in material and workmanship,

- Conforms to Lexmark's official published specifications, and
- Is in good working order.

If this product does not function as warranted during the warranty period, contact a Remarketer or Lexmark for repair without charge.

If this product is a feature or option, this statement applies only when that feature or option is used with the product for which it was designed. To obtain warranty service, you may be required to present the feature or option with the product.

If you transfer this product to another user, warranty service under the terms of this statement is available to that user for the remainder of the warranty period. You should transfer proof of original purchase and this statement to that user.

Warranty Service

The warranty period is 12 months and starts on the date of original purchase as shown on the purchase receipt.

To obtain warranty service you may be required to present proof of original purchase. Warranty service will be provided at a Remarketer or a Lexmark designated location. You may be required to deliver your product to the Remarketer or Lexmark, or ship it prepaid and suitably packaged to a Lexmark designated location. You are responsible for loss of, or damage to, a product in transit to the Remarketer or the designated location.

When warranty service involves the exchange of a product or part, the item replaced becomes the property of the Remarketer or Lexmark. The replacement may be a new or repaired item. The replacement item assumes the remaining warranty period of the original product.

Replacement is not available to you if the product you present for exchange is defaced, altered, in need of a repair not included in warranty service, or damaged beyond repair. Also, such product must be free of any legal obligation or restrictions that prevent its exchange.

Before you present this product for warranty service, remove all programs, data, and removable storage media.

For further explanation of your warranty alternatives and the nearest Lexmark authorized servicer in your area, please contact Lexmark at 1-800-LEXMARK (1-800-539-6275), or on the World Wide Web at <http://www.lexmark.com>.

Extent of Warranty

We do not warrant uninterrupted or error-free operation of a product.

Warranty service does not include repair of failures caused by:

- modification or attachments
- accidents or misuse
- unsuitable physical or operating environment
- maintenance by anyone other than Lexmark or a Lexmark authorized servicer
- operation of a product beyond the limit of its duty cycle
- failure to have installed a maintenance kit as specified (if applicable)
- use of printing media outside of Lexmark specifications
- use of other than Lexmark supplies (such as toner cartridges, inkjet cartridges, and ribbons)
- use of other than Lexmark product or component

ALL EXPRESS AND IMPLIED WARRANTIES, INCLUDING THE IMPLIED WARRANTIES OF MERCHANTABILITY AND FITNESS FOR A PARTICULAR PURPOSE, ARE LIMITED IN DURATION TO THE WARRANTY PERIOD. NO WARRANTIES, EXPRESS OR IMPLIED, WILL APPLY AFTER THIS PERIOD.

Limitation of Liability

Your sole remedy under this Statement of Limited Warranty is set forth in this section. For any claim concerning performance or nonperformance of Lexmark or a Remarketer for this product under this Statement of Limited Warranty, you may recover actual damages up to the limit set forth in the following paragraph.

Lexmark's liability for actual damages from any cause whatsoever will be limited to the greater of 1) \$5,000 or 2) the amount you paid for the product that caused the damages. This limitation of liability will not apply to claims by you for bodily injury or damage to real property or tangible personal property for which Lexmark is legally liable. In no event will Lexmark be liable for any lost profits, lost savings, incidental damage, or other economic consequential damages. This is true even if you advise Lexmark or a Remarketer of the possibility of such damages. Lexmark is not liable for any claim by you based on a third party claim.

This limitation of remedies also applies to any developer of materials supplied to Lexmark. Lexmark's and the developer's limitations of remedies are not cumulative. Such developer is an intended beneficiary of this limitation.

Additional Rights

Some states do not allow limitations on how long an implied warranty lasts, or do not allow the exclusion or limitation of incidental or

consequential damages. If such laws apply, the limitations or exclusions contained in this statement may not apply to you.

This warranty gives you specific legal rights. You may also have other rights which vary from state to state.

Glossary

- application software** A software product, such as a spreadsheet or word processing program, that is designed for use on a personal computer.
- Air Brush** Air Brush is a name for a modified Floyd-Steinberg Error-Diffusion, sometimes called the diffusion or scatter style of printing.
- dithering** When images are printed using the dithering selections from the halftoning area, the printer driver uses a matrix of dots to represent the image. You may need to experiment to find the halftone best suitable for a particular picture. In most cases, the Air Brush setting produces the best results.
- driver** see *printer driver*.
- fine dither** A halftone method used for detailed graphics with limited shading.
- font** A set of characters of a given size and style.
- halftone** An array in which dots are placed to simulate colors and shades of gray.
- hard drive** A stand-alone hardware unit that offers additional data storage for your computer and can read and store data on diskettes. Also called hard disk or fixed disk drive.

icon	A representation or symbol.
inkjet	A non-impact printing technology that creates characters and graphics by the composition of programmed patterns of ink dots.
interface	A data conversion device that allows communication between the printer and the computer. See also <i>parallel interface</i> .
line art	A halftone method used for simple line art and computer graphics.
MB (megabyte)	A unit of measure for storage capacity. One megabyte equals 1,048,576 bytes.
parallel interface	A type of connection that links a printer to a computer, by which all 8 bits of a character are sent at the same time. See also <i>interface</i> .
print cartridge	The ink reservoir and printhead unit.
printer driver	A program that translates the language of a software application to the language of the printer so the two can communicate data.
printer setup	The <i>printer driver</i> is designed to provide the best print output default setting for your printer.
software application	Any program loaded on your computer used to perform a specific task; for example, a word processing or spreadsheet program.
specialty media	Any print media that requires manual feeding. This includes greeting cards, iron-on transfers, and index cards.

Index

A

- aligning printheads 27
- automatic feeder
 - loading 14
 - location 14

B

- bidirectional communications
 - disabling 46
 - problems
 - diagnosing 44
 - solving 45

C

- camera card
 - deleting photo files 49
- carrier contacts, cleaning 32
- cartridges, see *print cartridges*
- coated paper
 - ordering 66
 - types and sizes 11

D

- disposing of cartridges 26
- DOS printing
 - changing print settings 35

- from native DOS 39
- from Windows 36
- to file 38
- to other printers 38, 41
- to your Lexmark printer 41

E

- electronic emission notices 72
- Energy Star 71
- envelopes
 - loading 16, 18
 - types and sizes 12
- error messages 50
- exit tray, removing 64

F

- feeding problems 57

G

- glossy film
 - loading 14, 18
 - ordering 67
 - types and sizes 10
- greeting cards
 - loading 16, 18
 - ordering 68
 - types and sizes 14

I

iron-on transfers
loading 18
ordering 69
types and sizes 14

L

labels
loading 14
ordering 68
types and sizes 13

M

manual feeder
loading 18
location 18

O

opening
Printer Driver 8
ordering supplies 65

P

paper
coated 66
feed problems 57
loading 14, 18
ordering 66
photo 66
types and sizes 11
paper exit tray, removing 64
parallel cable, ordering 65
photo files, deleting 49
photo paper
loading 18
ordering 66
types and sizes 10

power supply replacement 52
print cartridges
aligning 27
cleaning 29
cleaning carrier contacts 32
disposing of 26
installing 22
ordering 65
preserving 21
removing 22
replacing 22
wiping nozzles and contacts
30

print nozzles
cleaning 29
testing 29
wiping 30

print quality 59

printer

button 5
dimensions 4
features 2
light 5
parts 2
software
description 7
problems 63
specifications 2

Printer Driver, opening 8

printing problems 52

R

replacing power supply 52
requirements, system 4

S

safety information 73
software

- description 7
- problems 63
- supplies, ordering 65
- system requirements 4

T

- transparencies
 - loading 14, 18
 - ordering 67
 - types and sizes 10, 12
- troubleshooting 43

U

- United Kingdom Telecommunications Act 1984 73

W

- warranty information 79

You may use this form to communicate your comments about this publication, with the understanding that Lexmark may use or distribute whatever information you supply in any way it believes appropriate without incurring any obligation to you.

1. Did you find the book well organized?

Yes No

2. Was the content of the book accurate and complete?

Yes No

3. Was the book easy to use?

Yes No

4. What can we do to improve the book?

5. What type of digital camera do you own?

6. How do you plan to use this printer?

_____ Without a computer _____ Connected to a computer

_____ Both without a computer and connected to a computer

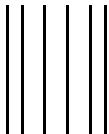

NO POSTAGE
NECESSARY
IF MAILED
IN THE
UNITED STATES

BUSINESS REPLY MAIL

FIRST CLASS MAIL PERMIT NO. 2659 LEXINGTON, KY

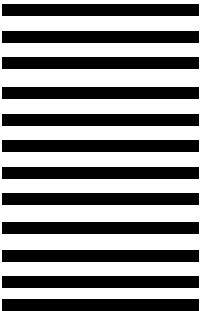

POSTAGE WILL BE PAID BY ADDRESSEE

Lexmark International, Inc.
Department F95, Building 035-3
740 NEW CIRCLE ROAD NW
LEXINGTON KY 40511-9954



Fold Here

Cut Along Line

Tape

Please Do Not Staple

Tape

Free Manuals Download Website

<http://myh66.com>

<http://usermanuals.us>

<http://www.somanuals.com>

<http://www.4manuals.cc>

<http://www.manual-lib.com>

<http://www.404manual.com>

<http://www.luxmanual.com>

<http://aubethermostatmanual.com>

Golf course search by state

<http://golfingnear.com>

Email search by domain

<http://emailbydomain.com>

Auto manuals search

<http://auto.somanuals.com>

TV manuals search

<http://tv.somanuals.com>