

M410

M412

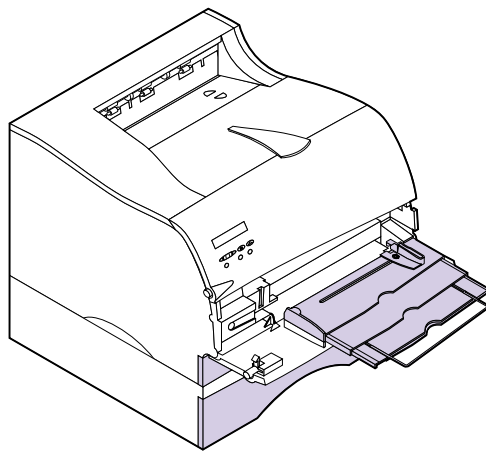

Edition: May 2000

The following paragraph does not apply to any country where such provisions are inconsistent with local law: LEXMARK INTERNATIONAL, INC., PROVIDES THIS PUBLICATION "AS IS" WITHOUT WARRANTY OF ANY KIND, EITHER EXPRESS OR IMPLIED, INCLUDING, BUT NOT LIMITED TO, THE IMPLIED WARRANTIES OF MERCHANTABILITY OR FITNESS FOR A PARTICULAR PURPOSE. Some states do not allow disclaimer of express or implied warranties in certain transactions; therefore, this statement may not apply to you.

This publication could include technical inaccuracies or typographical errors. Changes are periodically made to the information herein; these changes will be incorporated in later editions. Improvements or changes in the products or the programs described may be made at any time.

A form for the reader's comments is provided at the back of this publication. If the form has been removed, comments may be addressed to Lexmark International, Inc., Department F95/035-3, 740 West New Circle Road, Lexington, Kentucky 40550, U.S.A. In the United Kingdom and Eire, send to Lexmark International Ltd., Marketing and Services Department, Westhorpe House, Westhorpe, Marlow Bucks SL7 3RQ. Lexmark may use or distribute any of the information you supply in any way it believes appropriate without incurring any obligation to you. You can purchase additional copies of publications related to this product by calling 1-800-553-9727. In the United Kingdom and Eire, call 0628-481500. In other countries, contact your point of purchase.

References in this publication to products, programs, or services do not imply that the manufacturer intends to make these available in all countries in which it operates. Any reference to a product, program, or service is not intended to state or imply that only that product, program, or service may be used. Any functionally equivalent product, program, or service that does not infringe any existing intellectual property right may be used instead. Evaluation and verification of operation in conjunction with other products, programs, or services, except those expressly designated by the manufacturer, are the user's responsibility.

© Copyright 1999, 2000 Lexmark International, Inc.
All rights reserved.

UNITED STATES GOVERNMENT RESTRICTED RIGHTS

This software and documentation are provided with RESTRICTED RIGHTS. Use, duplication or disclosure by the Government is subject to restrictions as set forth in subparagraph (c)(1)(ii) of the Rights in Technical Data and Computer Software clause at DFARS 252.227-7013 and in applicable FAR provisions: Lexmark International, Inc., Lexington, KY 40550.

Table of Contents

Introduction	ix
About This Book	ix
Other Information	x
Online Documents	x
Trademarks	xi
1 Setting Up Your Printer	1
Unpacking Your Printer	1
Removing Print Cartridge Packaging	2
Installing the Print Cartridge	5
Loading the Standard Input Tray	6
Installing the Paper Bail	11
Connecting Your Printer to a Computer	12
Using a Parallel Cable	12
Using a USB Cable	14
Plugging the Printer In	20
Turning the Printer Power On	20
Printing the Menu Settings Page	21
Installing the Operator Panel Overlay	22
Changing the Operator Panel Display Language	23
Installing Printer Drivers and Utilities	24

2	MarkVision	25
	MarkVision Printer Management Software	25
	Operating Systems Supported	25
	Introducing MarkVision	25
	MarkVision for Intranet Servers	26
	Introducing MarkVision for Intranet Servers	26
	MarkVision for UNIX Networks	27
	Lexmark MarkTrack	28
	Lexmark NetPnP	29
	Software Installation and Distribution Tools	29
	Optra Forms	30
	Solaris Ready Printers for Sun Customers	31
3	Using the Operator Panel and Menus	33
	Using the Operator Panel	34
	Printer Indicator Light	34
	Operator Panel Buttons	35
	Printer Messages	37
	Status Messages	37
	Attendance Messages	37
	Service Messages	37
	Operator Panel Menus	38
	Printing the Menu Settings Page	39
	Changing Menu Settings	40
	Disabling the Operator Panel Menus	41
	Overview of Printer Menus	43
	Paper Menu	44
	Finishing Menu	53
	Utilities Menu	57
	Job Menu	59
	Quality Menu	71
	Setup Menu	73
	PCL Emul Menu	79
	PostScript Menu	83
	Parallel Menu	84
	Serial Menu	87
	Network Menu	91

Infrared Menu	93
LocalTalk Menu	96
USB Menu	99
Fax Menu	102
Config Menu	106
Understanding Print and Hold Jobs	108
Confidential Jobs	108
Held Jobs	109
Printing and Deleting Held Jobs	111
Entering a Personal Identification Number (PIN)	111
Print and Hold Formatting Errors	113

4 Using Print Materials 115

Paper Sources and Sizes	116
Print Material Guidelines	118
Paper	118
Letterhead	118
Transparencies	119
Envelopes	119
Labels	120
Card Stock Guidelines	122
Storing Print Material	123
Loading Print Material	124
Loading an Input Tray	124
Loading the Multipurpose Feeder	130
Using the Paper Exits (Output Bins)	133
Using the Standard Output Bin	133
Using the Rear Output Bin	134
Printing on Letterhead	135
Tray Linking	135
Manual Duplex Printing	136
Duplex Printing from the Multipurpose Feeder	136
Duplex Printing from the Trays	136
Avoiding Paper Jams	137

5 Multipurpose Feeder 139

Multipurpose Feeder Guidelines	140
Opening the Multipurpose Feeder	141
Loading the Multipurpose Feeder	143
Loading Print Material	143
Using the Multipurpose Feeder	149
Closing the Multipurpose Feeder	150

6 Understanding Printer Messages 151

Status Messages	151
Line 1 Messages	152
Warning Messages	158
Attendance Messages	159

7 Solving Printer Problems 173

Display Problems	175
Printing Problems	176
Print Quality Problems	178
Option Problems	180
Network Printing Problems	181
Other Problems and Questions	182

8 Clearing Jams 183

Possible Paper Jam Areas	184
200 and 201 Paper Jam - Remove Cartridge	184
202 Paper Jam - Open Rear Door	186
203 Paper Jam - Short Paper	190
250 Paper Jam - Check MP Feeder	192

9 Maintaining Your Printer 193

Ordering a Print Cartridge	193
Storing the Print Cartridge	194
Replacing the Print Cartridge	194
Cleaning the Printhead Lens	195
Ordering a Charge Roll Kit	195

10	Fax	197
	Understanding the Fax Port	197
	Choosing Hardware	197
	Setting Up a Fax Port	198
	Resetting a Fax Port	199
	Disabling a Fax Port	200
11	Memory and Option Cards	201
	Accessing the Printer System Board	201
	Understanding Memory Options	206
	Printer Memory	206
	Flash Memory	206
	Installing Memory Options	207
	Removing Memory Options	210
	Understanding Option Cards	211
	Internal Print Server (Internal Network Adapter or INA)	211
	Tri-Port Interface Option Card	212
	Hard Disk Option	212
	Parallel/USB Interface Option Card	215
	Installing an Option Card	216
	Removing an Option Card	219
	Closing the Printer System Board	220
12	Optional 500-Sheet Drawer	223
	Installing the Optional Drawer	223
13	Infrared Adapter	227
	Connecting the Cable and Using the Infrared Adapter	227
14	Verifying the Installation of Options	229
	Printing the Menu Settings Page	229
	Appendix A: Understanding Fonts	231

Typefaces and Fonts	231
Weight and Style	231
Pitch and Point Size	232
Bitmapped and Scalable Fonts	234
Resident Fonts	235
Symbol Sets	239
Symbol Sets for PCL 6 Emulation	239
Downloadable Fonts	241
Printing a Font Sample List	242
Appendix B: Notices	243
Appendix C: Safety Information	253
Appendix D: Warranty	265
Glossary	269
Index	285

Introduction

About This Book

This *User's Guide* contains information about the Lexmark Optra M410 and M412 laser printers. It provides setup instructions for the printer and printer options as well as information about loading print material, changing printer settings, replacing printer supplies, and troubleshooting problems.

Keep this book in a handy place and use it as a reference when you have a question about printer function or if you encounter a printing problem.

It may be helpful for you to recognize the following conventions used throughout this book:

Note: A note provides information you may find useful.

Warning! A warning identifies something that could damage your printer hardware or software.

Caution! A caution identifies something that could cause you harm.

- Notes, warnings, and cautions appear in the left column for easy reference.
- Operator panel buttons are printed in boldface type:
Press **Go** after changing a menu setting.
- Messages, menu names, menu items, and menu settings that appear on the operator panel display are also printed in boldface type:

If **Load Tray 1** appears on the operator panel display, you must load print material in tray 1 and press **Go** before you can resume printing.

The **Paper Source** setting is available in the **PAPER MENU**.

Other Information

In addition to this *User's Guide*, Lexmark offers the following sources of information about your printer and other Lexmark products and services.

Online Documents

The *Drivers, MarkVision and Utilities* compact disc (CD) that comes with your printer contains several online documents. Refer to the booklet that comes with the CD for launching instructions. Once you launch the CD, click **View Documentation** to display a list of available documents.

The CD includes:

The MarkVision printer utility information, which provides step-by-step instructions for installing MarkVision for Windows 95/98/2000, Windows NT 4.0, Macintosh, and OS/2 on several different networks. It also describes some of the most popular MarkVision features.

- Documents which provide general information about setting up an optional print server after installing it in your printer.
- Documents which describe font options and available resources.
- A *Card Stock & Label Guide* which provides detailed information about selecting print material appropriate for your printer.
- A *Technical Reference* which includes information about printer languages and commands, interface specification, and printer memory management.

Trademarks

Lexmark, Lexmark with diamond design, MarkNet, MarkVision, and Optra are trademarks of Lexmark International, Inc., registered in the United States and/or other countries.

MarkTrack, Optra Forms, and PictureGrade are trademarks of Lexmark International, Inc.

Operation ReSource is a service mark of Lexmark International, Inc.

PCL[®] is a registered trademark of the Hewlett-Packard Company. PCL 6 is Hewlett-Packard Company's designation of a set of printer commands (language) and functions included in its printer products. This printer is intended to be compatible with the PCL 6 language. This means the printer recognizes PCL 6 commands used in various application programs, and that the printer emulates the functions corresponding to the commands.

PostScript[®] is a registered trademark of Adobe Systems Incorporated. PostScript 3 is Adobe Systems' designation of a set of printer commands (language), fonts, and functions included in its software products. This printer is intended to be compatible with the PostScript 3 language. This means the printer recognizes PostScript 3 commands used in various application programs, and that the printer emulates the functions corresponding to the commands.

Details relating to compatibility are included in the *Technical Reference*.

The following terms are trademarks or registered trademarks of these companies.

Albertus	The Monotype Corporation plc.
Antique Olive	Monsieur Marcel OLIVE
Arial	The Monotype Corporation plc.
CG Omega	A product of Bayer Corporation
CG Times	Based on Times New Roman under license from The Monotype Corporation plc, is a product of Bayer Corporation
Helvetica	Linotype-Hell AG and/or its subsidiaries
Intellifont	Bayer Corporation
ITC Bookman	International Typeface Corporation
ITC Zapf Chancery	International Typeface Corporation
LocalTalk	Apple Computer, Inc.
Macintosh	Apple Computer, Inc.
Marigold	AlphaOmega Typography, Inc.
Palatino	Linotype-Hell AG and/or its subsidiaries
Pantone	Pantone, Inc.
PostScript	Adobe Systems Incorporated
Times New Roman	The Monotype Corporation plc.
TrueType	Apple Computer, Inc.
Univers	Linotype-Hell AG and/or its subsidiaries
Wingdings	Microsoft Corporation

Other trademarks are the property of their respective owners.

Setting Up Your Printer

1

Complete the following sections to set up your Lexmark™ Optra™ M410 and M412 printers.

Unpacking Your Printer

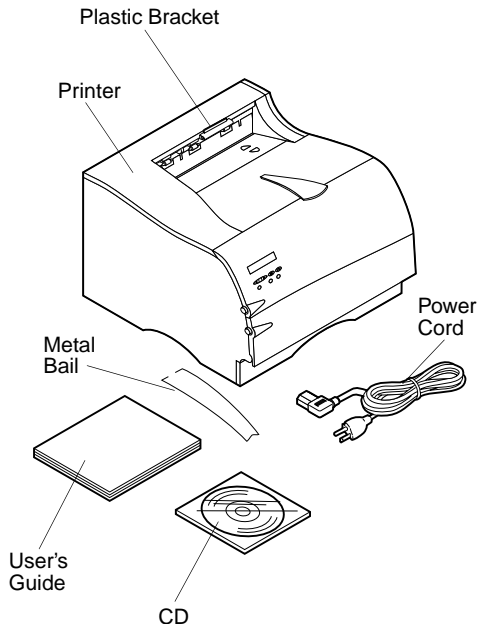

1 Remove the printer and all items from the packaging carton.

Save the carton and packing materials in case you need to repack the printer for service or storage.

2 Make sure you have the items shown.

If any items are missing, contact the place where you bought your printer.

3 Place the printer on a flat, sturdy surface in a well-ventilated area.

Allow at least 304.8 mm (12 in.) of clearance on all sides of the printer. Since you may want to install the optional 500-sheet drawer, leave at least 129.6 mm (5.1 in.) clearance above the printer. Leave enough space in front of the printer to allow for easy paper access.

Use the following information to help determine where to place your printer.

Characteristic	Measurement
Depth	435 mm (17.1 in.)
Height	314 mm (12.4 in.)
Width	405 mm (15.9 in.)
Weight ¹	14.8 kg (32.6 lb)
Footprint	246 sq. in.
¹ Weight of printer includes print cartridge.	

Do not place the printer:

- In direct sunlight.
- Near heat sources or air conditioners.
- In dusty or dirty environments.

Removing Print Cartridge Packaging

To remove the print cartridge packaging:

- 1 Push the upper release latch to release the upper front door.**

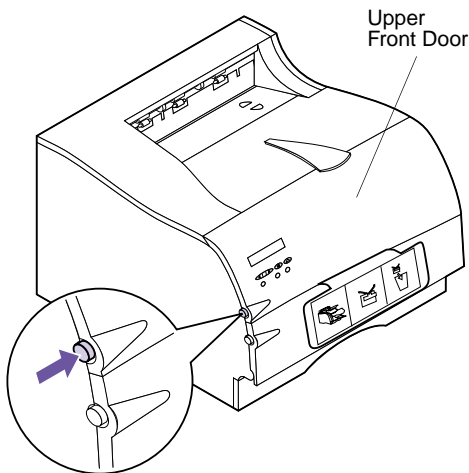

2 Raise the upper front door.

It remains in place.

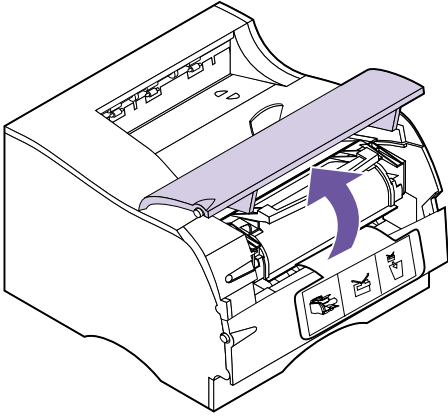

3 Grasp the print cartridge by the handgrip.

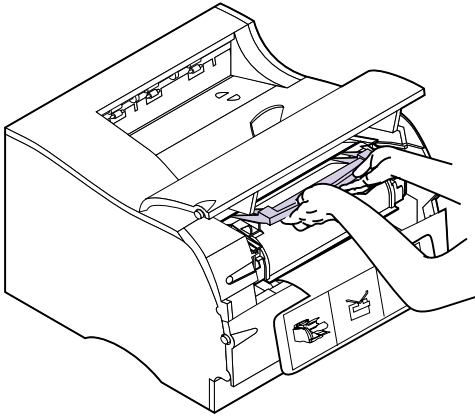

- 4** Lift the print cartridge up and pull out.

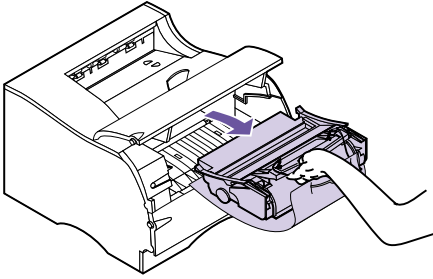

- 5** Pull up on each end of the plastic piece and then remove the packaging material.

Discard all packaging material: the plastic piece, the foam, and the paper connected to the foam.

- 6** Continue with “Installing the Print Cartridge” on page 5.

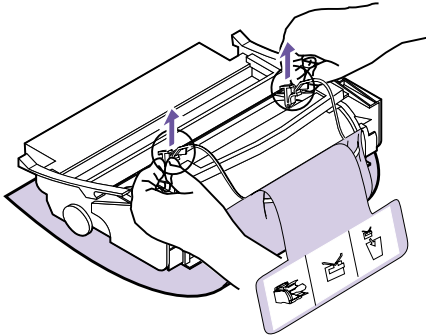

Installing the Print Cartridge

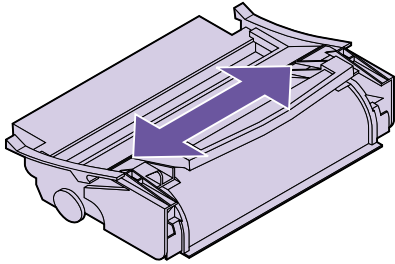

To prepare the print cartridge for printing:

- 1 Gently shake the print cartridge side-to-side to distribute the toner.**

- 2 Insert the print cartridge:**

- a Align the tabs located on each side of the print cartridge with the slots on either side of the print cartridge cradle as shown.**

Use the colored arrows inside the printer for placement.

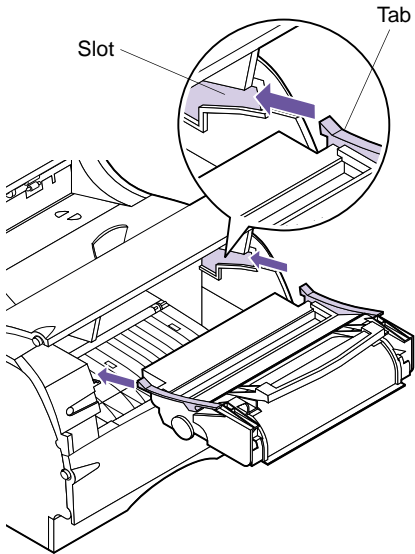

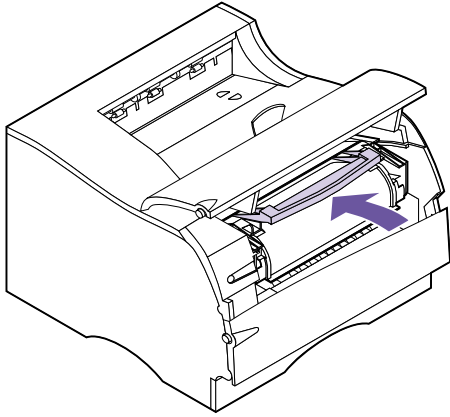

b Slide the print cartridge straight back into the printer until it *snaps* into place.

3 Close the upper front door.

You cannot close the door completely if the print cartridge is not installed correctly.

Loading the Standard Input Tray

Your printer has one standard 250-sheet input tray that holds five paper sizes. For information on the different sizes and types of print material you can use with your printer, see “Using Print Materials” on page 115.

For information on loading envelopes and other types of print material, see “Multipurpose Feeder” on page 139.

To load paper:

1 Pull the input tray straight out of the printer.

Remove the input tray completely from the printer.

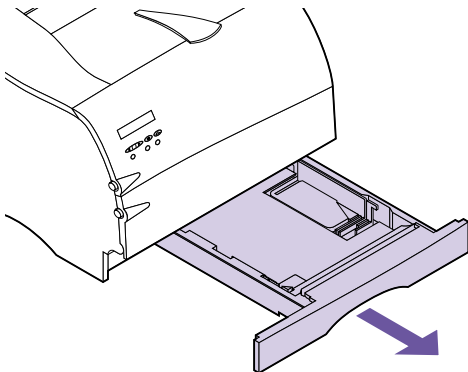

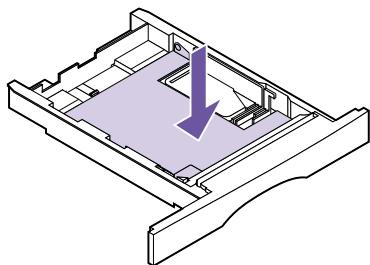

- 2 Press down on the metal plate until it locks into place.**

The metal plate remains stationary on the inside bottom of the input tray.

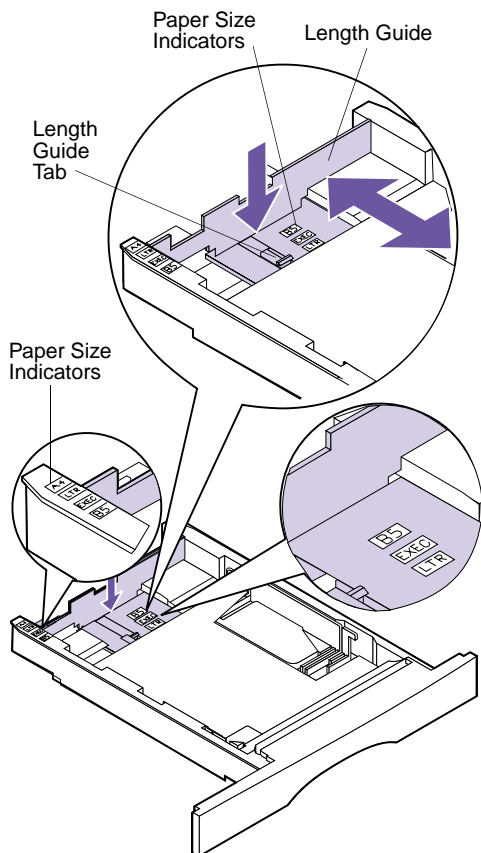

- 3 Press down on the length guide tab with one hand, and with the other hand slide the length guide to the correct position for the size paper you are loading.**

Use the paper size indicators to adjust the length guide for one of the following five paper sizes: A4, B5, LTR (Letter), LGL (Legal), and EXEC (Executive).

Note: The paper size indicators are paper size abbreviations used for the placement of the length guide as shown. This example shows how to adjust for letter-size paper (LTR).

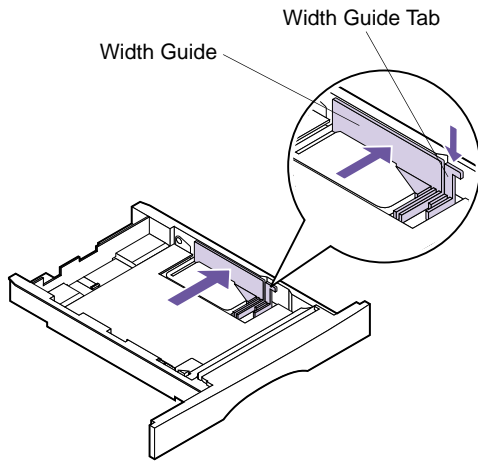

- 4 Press down on the width guide tab and slide the width guide to the far right side of the input tray as shown.**

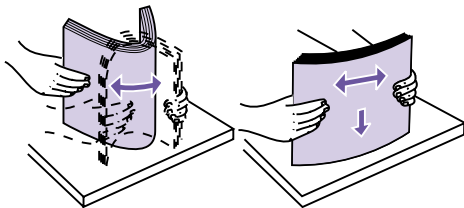

- 5 Flex the sheets back and forth to loosen them, then fan them. Do not fold or crease the paper. Straighten the edges on a level surface.**

For this setup, load letter-size paper.

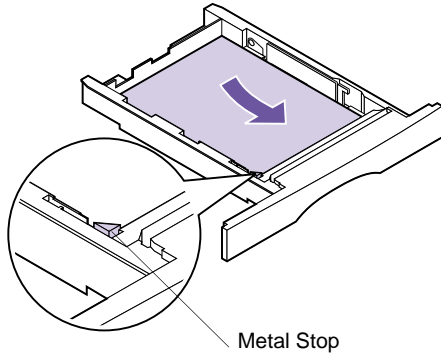

6 Place the paper against the left side of the input tray and insert it under the metal stop.

Make sure the recommended print side is face down and the front edge is placed toward the front of the input tray.

For information on how to load letterhead, see “Printing on Letterhead” on page 135.

Note: Make sure the paper fits easily under the metal stop and is not bent or wrinkled. Do not raise the metal stop or force paper under the metal stop. Overfilling the input tray may cause paper jams.

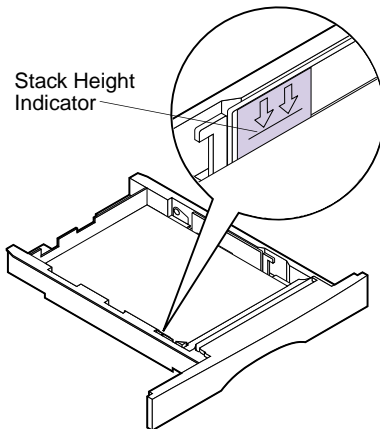

7 Do not exceed the maximum stack height indicated by the line under the arrows.

Note: Overfilling the input tray may cause paper jams.

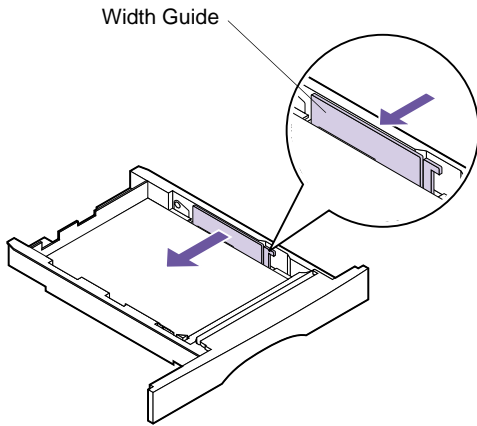

- 8 Push on the right side of the width guide to move it to the left until it lightly touches the edge of the paper.**

Note: Sliding the width guide too tight against the paper may cause misfeeds.

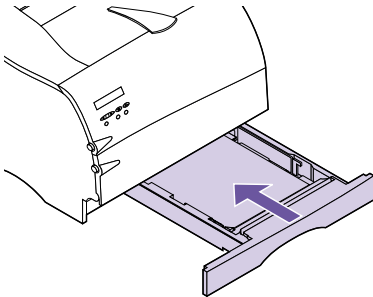

- 9 Slide the input tray all the way into the printer until it *snaps* into place.**

Installing the Paper Bail

The paper bail helps prevent offset bin stacking by guiding print material into the standard output bin.

The paper bail consists of two parts: a plastic bracket already installed on the printer and a metal bail.

Complete the following steps to install the metal bail:

- 1** Locate the metal bail that comes with your printer.
- 2** Orient the metal bail as shown.
- 3** Place the tips of the metal bail into the holes located on either end of the plastic bracket as shown.

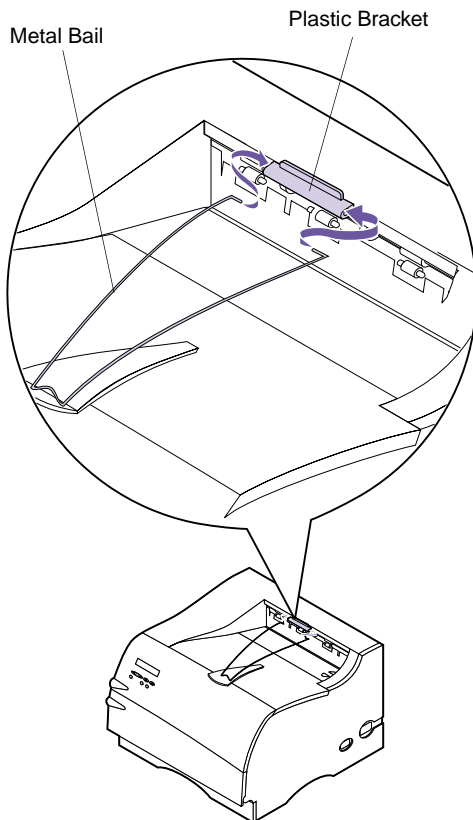

Note: The paper bail is *not* depicted in other illustrations throughout this book now that you have installed it.

Connecting Your Printer to a Computer

Using a Parallel Cable

To print from your computer, you need to connect your printer to your computer with either a parallel interface cable or a Universal Serial Bus (USB) cable.

Your printer uses an IEEE 1284-compliant parallel cable that supports bidirectional communication. We recommend Lexmark part number 1329605 (10 ft) or 1427498 (20 ft). If you use a cable other than an IEEE-compliant cable, you may not be able to access all of your printer functions.

- 1 Turn the printer power Off (O) and unplug the printer power cord from the electrical outlet.**

Caution! To avoid electrical shock hazards, make sure your computer power is Off (O) and unplug all computer equipment before connecting cables.

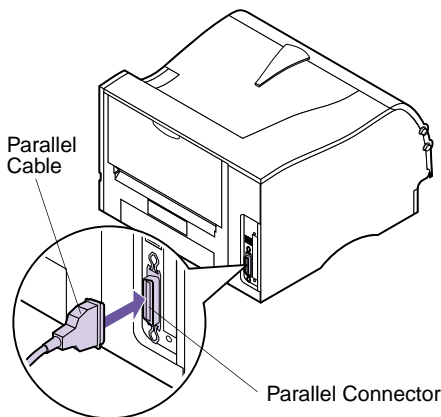

- 2 Align and plug the parallel cable into the parallel connector as shown.**

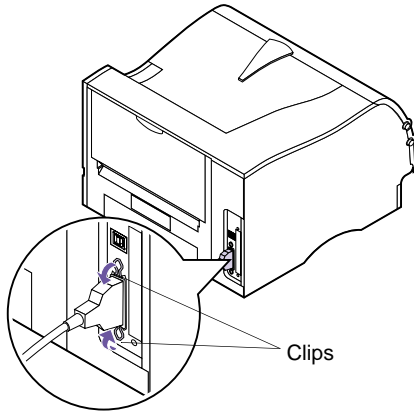

- 3** Push the clips at each end of the connector down into the notches on the plug as shown. The clips *snap* into the notches.
- 4** Connect the other end of the parallel cable to the back of your computer. Tighten the screws on the parallel cable to the computer.
- 5** Check the parallel cable connections to make sure they are completely secured.
- 6** Continue with “Plugging the Printer In” on page 20.

Using a USB Cable

Your printer has one standard USB port located on the printer system board.

Complete the following steps to connect your printer using a USB cable.

For Windows 2000 users:

- 1** Make sure the computer and printer power are Off (O) and the printer power cord is unplugged from the electrical outlet.
- 2** Connect the USB cable to the port on the back of your computer.
- 3** Connect the other end of the cable to the USB port on the back of your printer.
- 4** Turn on your computer and your printer.
- 5** When the Found New Hardware Wizard screen appears, select Cancel to close the wizard.
- 6** Insert the CD that came with your printer and select Start.
- 7** From the Start menu, select Run, then click Browse.
- 8** Click on the My Computer shortcut in the Browse window, double-click on the CD icon, and double-click on the Setup icon.
- 9** Click OK to start the printer driver installation program.
- 10** Follow the installation instructions in the printer drivers dialog box.
- 11** In the Print to the following port check box, select the USB port that best describes the order you've connected USB printers to your computer (for example, the first USB printer is USB001, the second USB002, and so on).

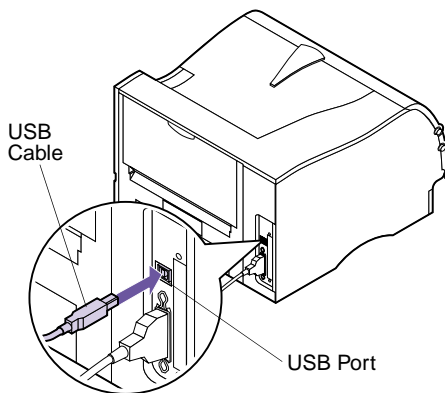

- 12** In the **Select a port for this printer** check box, select the **USB port** that best describes the order you've connected USB printers to your computer (for example, the first USB printer is **USB001**, the second **USB002**, and so on).
- 13** When you finish, exit the setup program and remove the CD from your computer.

For Windows 98 users:

- 1** Make sure the printer power is **Off (O)** and the printer power cord is unplugged from the electrical outlet.
- 2** Align and plug the USB cable into the USB port on the back of your printer as shown.
- 3** Connect the other end of the USB cable to the back of your computer.
- 4** Check the cable connections to make sure they are completely secured.
- 5** Follow the steps under **"Plugging the Printer In"** on page 20.
- 6** Follow the steps under **"Turning the Printer Power On"** on page 20.
- 7** Complete the following steps to setup the printer port and install the correct drivers.

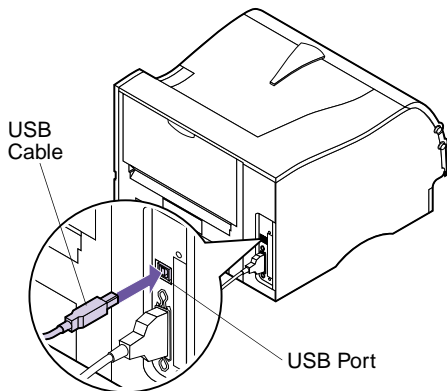

When you turn the printer power **On (I)**, the **Add New Hardware Wizard** screen appears on your computer.

- a** Click **Next**.
- b** Click the default to search for the best driver. Click **Next**.
- c** Click to clear the check boxes for **Floppy Disk or CD-ROM**.

d Insert the compact disc (CD) that came with your printer.

e Click **Specify a location**.

f Click **Browse**.

g Scroll down until you locate your CD-ROM drive. Double-click to select it.

h Highlight the folder for WIN98USB and click **OK**.

i Click **Next**.

A screen displays indicating the application is looking for this laser printer to verify the driver for the printer.

j Click **Next**.

Wait as the information processes. When the next screen appears that tells you the software is installed, click **Finish**. Complete the following to install the printer driver.

k Click **Install Software**.

l Click **Printer Software**.

The **Choose your Installation Path** screen displays.

m Select **Install from this CD**.

The **License Agreement** displays.

n Click **Agree once you have read the agreement**.

o Select **Custom Install and click Next**.

Printer Drivers is selected as the default on the next screen.

p Click **Next**.

q Scroll through the list of printers on the left of the screen and click the check box to select **Optra M410** or **Optra M412**.

r Click the Add button.

The name of your printer moves to the box on the right of the screen.

s Click Next.

The Drivers tab screen displays.

t Highlight LPT1 in the top window of the screen for the PostScript language.

u Scroll to USB001 in the bottom window of the screen and select it.

v Return to the top window of the screen and select LPT1 for the PCL language.

w Scroll to USB001 in the bottom window of the screen and select it.

x Click Finish Installation.

Wait as the information processes.

y Click Yes to restart Windows.

z Click OK.

For Macintosh users:

- 1** Make sure the printer power is Off (O) and the printer power cord is unplugged from the electrical outlet.
- 2** Connect the end of the USB cable to the port on your computer.
- 3** Align and plug the other end of the USB cable into the port on the back of your printer as shown.
- 4** Follow the steps under “Plugging the Printer In” on page 20.
- 5** Follow the steps under “Turning the Printer Power On” on page 20.
- 6** Launch the CD to install the necessary items. Instructions to launch the CD are in the CD booklet.
- 7** Restart the computer.
- 8** Open the Apples Extras folder.
- 9** Open the Apple LaserWriter Software folder.
- 10** Open the Desktop Printer Utility application.
- 11** The New Desktop Printer screen displays.
- 12** Select Printer (USB) from the list and click OK.
- 13** In the USB printer selection area, click Change.
The USB printer dialog box displays.
- 14** Select Optra M410 or Optra M412 and click OK.
The previous screen displays. Notice the new printer icon.
- 15** In the PostScript printer description (PPD) file, click Auto Setup.
Wait for the information to process.

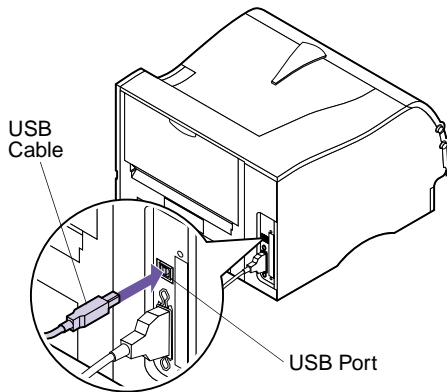

The previous screen displays. Notice the new printer icon.

Note: Both areas of the printer dialog box show the Optra M410 or Optra M412 printer icons.

16 Click Create.

A window appears for you to name the printer.

17 Type in the name of the printer or accept the default name.

18 Click Save.

19 Quit the Desktop Printer Utility application.

The printer icon displays on your Desktop.

20 Click the new desktop printer icon.

The Printing menu appears on the menu bar.

21 Scroll down in the Printing menu and select Set Default Printer.

A dark line appears around the printer in the printer icon to indicate it is selected as the default printer.

Plugging the Printer In

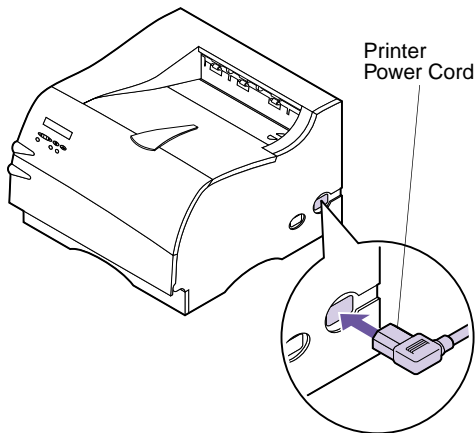

- 1** Plug the printer power cord into the connector as shown.
- 2** Plug the other end of the printer power cord into a properly grounded electrical outlet.
- 3** Continue with “Turning the Printer Power On” on page 20.

Turning the Printer Power On

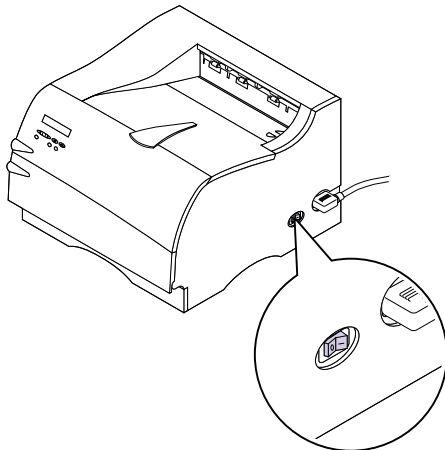

Turn the printer power On (|).

If an error message displays, see “Understanding Printer Messages” on page 151 for more information.

Printing the Menu Settings Page

The menu settings page shows current settings for the menu, a list of installed options, and available printer memory. You can use this page to verify that all printer options are properly installed and the printer settings are set to what you want.

Warning! Complete “Removing Print Cartridge Packaging” on page 2 before printing a page.

Note: See “Using the Operator Panel” on page 34 to identify the display and operator panel buttons if you need help.

- 1 Make sure the printer power is On (|) and the Ready status message appears on the display.**
- 2 Press Menu> or <Menu to enter the menus.**
- 3 Continue to press and release Menu> or <Menu until you see UTILITIES MENU on the second line of the display.**
- 4 Press Select.**
- 5 Press Menu> until Print Menu appears on the second line of the display.**
- 6 Press Select.**

The message **Printing Menu Settings** appears and remains on the operator panel display until the page prints. The printer returns to the **Ready** state after the menu settings page prints.

If an error message appears, see “Understanding Printer Messages” on page 151 for more information.

Installing the Operator Panel Overlay

If English is your preferred language, continue with “Installing Printer Drivers and Utilities” on page 24.

If English is not your preferred language, complete the following steps to customize the operator panel.

1 Locate the operator panel overlay.

If this *User’s Guide* is printed in a language other than English, an overlay for the operator panel is included with the printer. The overlay has translated names for the operator panel buttons.

2 Peel the protective backing off the overlay.

3 Align the operator panel overlay on the operator panel and press it into place as shown.

Rub the overlay firmly to make sure that it adheres securely.

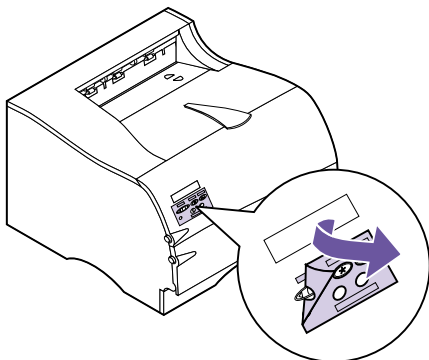
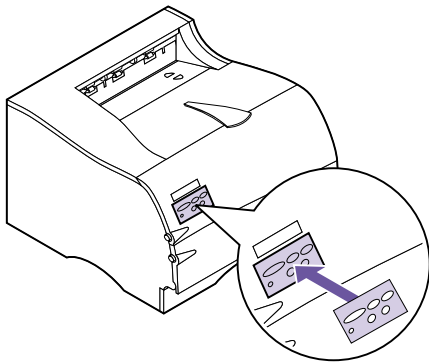

4 Peel the protective covering away from the top of the overlay.

5 Continue with “Changing the Operator Panel Display Language” on page 23 to change the display language to match the overlay.

Changing the Operator Panel Display Language

Complete the following steps to change the language of the menus and messages that appear on the operator panel display:

- 1 Press the Menu> or <Menu button to enter the menus.**
- 2 Continue to press and release Menu> or <Menu until SETUP MENU appears on the second line of the display.**
- 3 Press the Select button.**
- 4 Press Menu> until Display Language appears on the second line of the display.**
- 5 Press Select.**
- 6 Press Menu> until your preferred language appears on the second line of the display.**
- 7 Press Select.**

Note: The **Select** button acts upon information that appears on the second line of the operator panel display.

Note: See “Using the Operator Panel” on page 34 to identify the display and operator panel buttons if you need help.

The printer resets and displays text in the requested language.

Installing Printer Drivers and Utilities

Note: Consult your network software documentation for more information. Also, see “Introducing MarkVision” on page 25 for more information.

- 1** Locate the *Drivers, MarkVision and Utilities* CD that comes with your printer.

If your computer does not have a CD-ROM drive, you can transfer the information on the CD to diskettes. Locate a computer with a CD-ROM drive, start the CD-ROM utility, and follow the instructions presented to create diskettes.

- 2** Follow the instructions in the booklet included with the CD to start the printer setup utility.

The setup utility lets you install printer drivers and utilities to manage Lexmark printers attached to your network. See “Introducing MarkVision” on page 25 for more information.

- 3** If necessary, use standard network software to identify the printer to the LAN and to complete any other setup that may be needed.

MarkVision

2

MarkVision Printer Management Software

This section provides a brief overview of the MarkVision printer utility and some of its key features. For more information on MarkVision, refer to the online Help or the documentation on the *Drivers, MarkVision and Utilities* CD that comes with your printer:

- *Introduction to MarkVision*
- *Installation Tips*

Operating Systems Supported

MarkVision for Windows 95/98/2000, Windows NT 4.0, Macintosh, and OS/2 Warp is shipped with your printer on the *Drivers, MarkVision and Utilities* CD.

Introducing MarkVision

The MarkVision graphical user interface provides advanced, real-time, centralized management capabilities for Lexmark printers connected locally or attached directly to a network. Network users and administrators can also use the following MarkVision features to increase productivity:

- Centralized setup capabilities let you quickly configure and install multiple printers.
 - You can configure multiple printers simultaneously from one workstation.
 - Automatic network printer discovery and multi-adapter flash update let you set up and configure

Note: You can integrate MarkVision directly into your favorite network management software.

Note: Management capabilities for multivendor printers are available in some versions of MarkVision.

Lexmark network printers and change network addresses from one workstation.

- Use MarkVision to easily manage and monitor your Lexmark printers.
 - Messages on the MarkVision remote operator panel reflect printer real-time status.
 - The dynamic printer graphic provides a visual confirmation of installed options.
 - A list of installed features shows you printer capabilities.
- MarkVision provides the tools to make printer-related administrative tasks effortless.
 - Monitor network print jobs, change their printing order, and hold or delete specific jobs.
 - Use asset management options to maintain printer inventory, assign property tags, track page counts, and gather job statistics.
 - Download and manage resources such as fonts, demo pages, and overlays.

MarkVision for Intranet Servers

This section provides a brief overview of MarkVision for Intranet Servers and some of its key features. For more information on MarkVision for Intranet Servers, refer to the documentation installed with the software:

- *MarkVision for Intranets User's Guide.*
- *MarkVision Installation and Configuration Guide.*

This document is also located on the *Drivers, MarkVision and Utilities* CD that comes with your printer.

Introducing MarkVision for Intranet Servers

MarkVision for Intranet Servers is a Web-based printer management utility that:

- Lets you monitor and manage devices using a Web browser from any PC with intranet access.

- Enables print management over your existing intranet infrastructure using TCP/IP.
- Offers a cross-platform solution for Windows and UNIX users.
- Lets you manage multivendor printers.

Network users and administrators can also use the following MarkVision features to increase productivity.

Maps

Locate printers quickly in your organization by positioning printer icons on a map to show not only printer status, but also actual printer location.

Filters

Search for devices using criteria such as printer status and installed features.

Filters automatically organize printers into groups based on real-time status information.

Remote Updates

Remotely update firmware on multiple Lexmark print servers simultaneously.

MarkVision for UNIX Networks

MarkVision for UNIX/Sun offers enterprise scalability, reliability, and performance that helps you easily set up, manage, and maintain printers across networks. Ultimately, this reduces help desk costs and increases network administrator productivity using:

- Centralized Lexmark printer setup capabilities.
- Remote monitoring and management.
- Proactive status alerts on Lexmark printers.
- Tools that allocate printing expenses, balance workload, and access printing resources.

MarkVision Simple Network Management Protocol (SNMP) Services let administrators manage popular multivendor printers.

MarkVision for UNIX Networks and Intranet Servers is recommended to assist in remote printer setup for UNIX platforms.

To purchase MarkVision for UNIX, contact the place where you bought your printer or visit the Lexmark Web site at www.lexmark.com.

Lexmark MarkTrack

MarkTrack™ is a network printer reporting software package that helps administrators manage printing environments more efficiently. Administrators can use MarkTrack to:

- Retrieve and analyze network printer information from a Web browser.
- Allocate printing resources more efficiently.
- Make better purchasing decisions.
- Allocate printing costs to different departments.
- Provide statistical information on employee printing habits.
- Track Lexmark and SNMP-compliant printers.
- Collect, analyze, and create reports using MarkVision Printer Inventory and Job Statistics data or SNMP MIB data.
- Create reports using a Web server.
- View reports using a Web browser.
- Create an inventory of network printer assets automatically.
- Analyze printing for the enterprise.
- Plan ahead for supplies purchases, maintenance schedules, and printer replacement.

For more information on MarkTrack, refer to the product information, contact the place where you bought your

printer, or visit the Lexmark Web site at www.lexmark.com.

Lexmark NetPnP

NetPnP automates the configuration and installation of Lexmark printers on a network. NetPnP senses when a new printer is attached to the network, automatically creates a shared printer object on a Windows NT 4.0 system, and notifies users by e-mail that the printer is available for printing. It also notifies IT administrators by e-mail when a new printer is detected or when an error occurs during automatic printer installation.

- Lets administrators make printers available to users within seconds.
- Extends network printer installation to include the end user by installing all necessary components that enable printing to workstations across the network.
- Provides huge productivity gains when rolling out large numbers of network printers.
- Supports a wide range of printer installation options for IT administrators, from fully automatic installation to prompted confirmations.
- Lets you customize network printer installation in Windows NT environments running TCP/IP.
- Automates the setup of Lexmark network printers, eliminating more than a dozen steps in the process.

Software Installation and Distribution Tools

On the *Drivers, MarkVision and Utilities* CD, Lexmark's all-in-one software installation utility provides IT administrators with time-saving installation and distribution tools that enhance productivity and improve efficiency.

- Software installation and updates by way of the Lexmark Web site.

Users can initiate Web updates or schedule updates to run periodically. This ensures that users have the most recent version of Lexmark software and driv-

ers on their workstations with the least amount of effort.

- Scripting capability to distribute software to users on the network.

IT administrators can store software and driver installation settings in a file. This file can then be used to automatically distribute the software to multiple workstations simultaneously.

- Distribution of drivers with custom settings to users.

IT administrators can remotely install, update, and distribute drivers with custom settings to users on the network, eliminating time-consuming workstation driver installation and configuration.

Optra Forms

Optra Forms combines data from a customer's application with printer-resident electronic forms to produce completed forms such as invoices, statements, pick slips, labels, and purchase orders. Support for bar codes, specialized graphics and other options is included.

The same data can be sent to several remote printers with different resident forms so that the completed forms can be customized for the specific printer location. For example, the same purchase order information can be sent to different printers and printed with different addresses and logos.

Optra Forms:

- Requires no server-based or host-based merge program or software.
- Can be used:
 - With virtually any ASCII text print file from any platform, mainframe, AS/400, UNIX or workstation.
 - Over Coax, Twinax, parallel, serial or LAN (TCP/IP).
- Generally makes no changes to database applications.

- Prints different forms at different locations from the same database.
- Globally updates forms quickly and easily over the LAN.
- Provides support for bar codes, color, duplex, multi-page form sets, and more.
- Stores forms as efficient, compact forms in flash.
- Works with Optra M410 and M412 printers and the Optra T and Optra W laser printer families using the Optra Forms™ 1, 2, 4, 8, and 16MB Flash DIMMs or Optra Forms Hard Disk.

Solaris Ready Printers for Sun Customers

Solaris Ready printers are specially configured for Sun users. They are Ethernet-ready and include Sun-specific documentation as well as MarkVision for Sun Systems and Intranet Servers. These applications provide seamless installation in Sun Solaris network environments.

Using the Operator Panel and Menus

3

This chapter contains information about using the operator panel, changing printer settings, and understanding operator panel menus.

You can change most printer settings from your software application or printer driver. Settings you change from the application or driver apply only to the job you are preparing to send to the printer.

Note: Changes made to printer settings from a software application override changes made from the operator panel.

If there is a setting you cannot change from your software application, use the operator panel or the remote operator panel available from the MarkVision utility. See “MarkVision” on page 25 for information about MarkVision. Changing a printer setting from the operator panel or from MarkVision makes that setting the user default.

If you are familiar with using an operator panel similar to this, you may want to skip to “Overview of Printer Menus” on page 43.

Using the Operator Panel

The operator panel, on the front left-side of your printer, has a 2-line by 16-character liquid crystal display (LCD), one printer indicator light, and six buttons. Notice the Menu button is split into two functioning halves; therefore, it works like two buttons.

The numbers on the operator panel by the names of the buttons are only used for entering your Personal Identification Number (PIN) if you send a print job that is confidential. For more information, see **CONFIDENTIAL JOB** on page 60 and “Entering a Personal Identification Number (PIN)” on page 111.

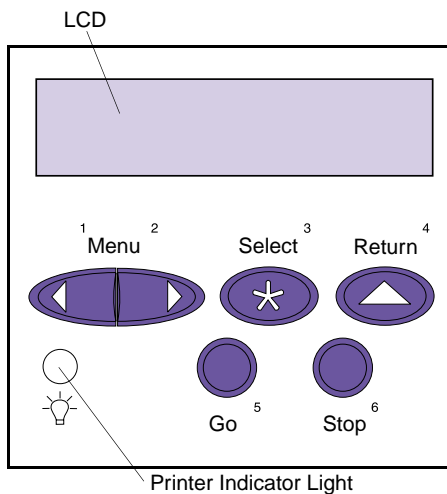

Printer Indicator Light

The printer indicator light gives information about the status of your printer.

Light State	Meaning
On Solid	The printer is On (I) and in the Ready state.
Blinking	The printer is On (I) and Busy .
Off	The printer is Off (O).

Operator Panel Buttons

Use the operator panel buttons to open a menu, scroll through a list of values, change printer settings, respond to printer messages, temporarily stop all print activity, and key in a PIN. The following table describes the functions of each button.

Note: Buttons act upon the information that displays on the second line of the operator panel except when using the buttons to key in a PIN.

If this *User's Guide* is printed in a language other than English, an operator panel overlay with translated buttons and light names is included with your printer. See "Installing the Operator Panel Overlay" on page 22 for more information.

Operator Panel Buttons

Button	Function
Go	<p>Press the Go button to:</p> <ul style="list-style-type: none"> Return to the Ready state if the printer is in an offline situation (the Ready message does not appear on the display). Exit printer menus and return to the Ready state. Clear operator panel error messages. Resume printing after loading print material and clearing paper jams. Exit Power Saver. <p>If you have changed printer settings from the operator panel menus, press Go before sending a job to print. The printer must display Ready for jobs to print.</p>
Menu> and <Menu	<p>Each end of the button has a function. Press the Menu> or <Menu button:</p> <ul style="list-style-type: none"> At the Ready message, to take the printer offline (out of the Ready state) and enter the menus. Menu> takes you to the first menu in the menus. <Menu takes you to the last menu in the menus. At the Busy message, to list the menu items in the JOB MENU. When the printer is offline: <ul style="list-style-type: none"> Press Menu> to go to the next item in the menus, or Press <Menu to go to the previous item in the menus. For menu items that have numerical values, such as Copies, press and hold Menu> to scroll forward, or <Menu to scroll backward. Release the button when the number you want displays.

Operator Panel Buttons (continued)

Button	Function
Select	Press the Select button to: <ul style="list-style-type: none">• Select the menu shown on the second line of the display. Depending on the type of menu, this action:<ul style="list-style-type: none">- Opens the menu and displays the first item in the menu.- Opens the menu item and displays the default setting.• Save the displayed menu item as the new default setting. The printer displays the Saved message briefly and returns to the menu item.• Clear certain messages from the operator panel display.• Continue printing after the Change <input source> message displays. See Change <input source> on page 167 for more information.
Return	Press the Return button to return to the previous menu level or menu item.
Stop	Press the Stop button at the Ready, Busy, or Waiting message to temporarily stop all activity and take the printer offline. The operator panel status message changes to Not Ready . No data is lost. Press Go to return the printer to the Ready, Busy, or Waiting state.
1, 2, 3, 4, 5, 6	The numbers located next to the names of the buttons are only used for entering your Personal Identification Number (PIN) after you send a Confidential Job. For more information, see “Entering a Personal Identification Number (PIN)” on page 111.

Printer Messages

Note: See “Understanding Printer Messages” on page 151 for a complete listing of all the printer messages.

The operator panel displays three types of messages:

- *Status messages* provide information about the current state of the printer.
- *Attendance messages* report printer errors that you must resolve.
- *Service messages* indicate printer failures that may require servicing.

Status Messages



When the **Ready** status message displays, the printer is ready to receive a print job. While a job is processing or printing, the **Busy** status message or a customized message appears on the first line of the operator panel display.

The screen to the left is an example of an operator panel message. The printer status appears on the first line of the display. The second line displays messages, such as warning messages, that give more information about printer status.

The **Busy** message identifies the printer language (PCL emulation) used for the print job. The **Parallel** message tells you that the printer is processing data received by the parallel port.

Attendance Messages



Attendance messages help you solve printer problems.

For example, if print material is jammed in the printer, the message **200 Paper Jam Remove Cartridge** appears on the display.

This message tells you to open the printer upper front door and check for jammed print material.

Service Messages

Service messages notify you of printer failures that may require a service call.

Operator Panel Menus

A number of menus are available to make it easy for you to change printer settings. The diagram on page 43 shows the menus and all of the menu items available in each menu. The items in each menu and the values you can select are described in more detail in the tables beginning on page 44.

Some menus appear only if a specific option is installed in the printer. Other menu items may only be effective for a particular printer language. You can select these values at any time, but they only affect printer function when you use the specified printer language.

Note: Changes made from a software application or driver override the user default settings made from the operator panel.

An asterisk (*) next to a value in the tables indicates the *factory default setting*. These settings are the original printer settings. (Factory defaults may vary for different countries.) See **Factory Defaults** on page 57 or on page 107 for more information.

When you select a new setting from the operator panel, the asterisk moves next to the selected setting to identify it as the current *user default setting*. These settings are active until new ones are stored or the factory defaults are restored. See “Changing Menu Settings” on page 40 for more information.

Printing the Menu Settings Page

The menu settings page shows current settings for the menus, a list of installed options, and available printer memory. You can use this page to verify that the printer options are properly installed and the printer settings are set to what you want.

See “Using the Operator Panel” on page 34 to identify the display and operator panel buttons if you need help.

Note: Before printing the menu settings page, make sure the selected paper source holds letter-, legal-, or A4-size paper, the **PAPER SIZE** setting is set to the correct size, and the **PAPER TYPE** setting for the paper source is **Plain Paper**.

To print a menu settings page:

- 1 Make sure the printer power is On (|) and the Ready status message appears on the display.**
- 2 Press Menu> or <Menu to enter the menus.**
- 3 Continue to press and release Menu> or <Menu until you see UTILITIES MENU on the second line of the display.**
- 4 Press Select.**
- 5 Press Menu> until Print Menus appears on the second line of the display.**
- 6 Press Select.**

The message **Printing Menu Settings** appears and remains on the operator panel display until the page prints. The printer returns to the **Ready** state after the menu settings page prints.

If an error message appears on the display, see “Understanding Printer Messages” on page 151.

- 7 If you installed options, verify that they are listed on the menu settings page under “Installed Features.”**

If an option you installed does not appear on the page, turn the printer power Off (O), unplug the printer power cord, reinstall the option, and print the menu settings page again.

Changing Menu Settings

You can use the operator panel to change printer settings and customize your printer to meet your specific needs.

To select a new value as the default setting:

1 From the Ready state, press Menu> or <Menu to enter the menus.

2 Continue to press and release Menu> or <Menu until the menu you need appears on the second line of the display.

See “Overview of Printer Menus” on page 43 for a list of the menus and their menu items.

3 Press Select.

The menu opens and the first menu item in the menu appears on the second line of the display.

4 Press Menu> or <Menu until the menu item you need appears on the second line of the display.

5 Press Select.

An asterisk (*) appears beside the current user default setting for that menu item.

Some menu items have submenus. For example, if you select **PAPER MENU**, and then select the **PAPER TYPE** menu item, you must select another menu (such as **Tray 1 Type**) before the available values display.

A value can be:

- An On or Off setting.
- A phrase or word that describes a setting.
- A numerical value that you can increase or decrease.

6 Press Menu> or <Menu until the value you need appears on the second line of the display.

Note: Changes made from a software application override the user default settings made from the operator panel.

Note: User default settings remain in effect until you save new settings or restore the factory defaults.

Disabling the Operator Panel Menus

Note: When the operator panel menus are disabled, access to the **JOB MENU** is permitted from the **Ready** and **Power Saver** states. Access to the **CONFIDENTIAL JOB** and **HELD JOBS** menu items is permitted from the **Ready** state only.

7 Press Select.

An asterisk (*) appears beside the value to indicate that it is now the user default setting. The display shows the new setting for one second and then clears. The **Saved** message displays, then the previous list of menu items appears on the operator panel display.

8 Press Return to go back to previous menus or menu items and set new default settings.

9 Press Go to return to Ready if this is the last printer setting you want to change.

To disable the menus so that changes cannot be made to the printer default settings:

1 Turn the printer power Off (O).

2 Press and hold the Select and Return buttons and turn the printer power On (|).

3 Release the buttons when Performing Self Test appears on the operator panel display.

When the printer self test completes, the **CONFIG MENU** displays.

4 Press Menu> until Panel Menus displays on the second line.

5 Press Select.

6 Press Menu> until Disable displays on the second line of the display.

7 Press Select.

8 The Saved message briefly appears, then Disabling Menu displays.

The CONFIG MENU displays again with Panel Menu on the second line.

9 Press Menu> until Exit Config Menu displays on the second line.

10 Press Select.

Activating Menu Changes briefly appears, and then Performing Self Test briefly appears. The printer returns to the Ready state.

To enable the menus, repeat the previous steps and select Enable instead of Disable.

Overview of Printer Menus

Menus or menu items in *italics* only appear on the display if the corresponding option is installed. Capitalized menu items (for example, PAPER SIZE) have submenus. See the tables on the following pages for a list of the values for each menu item.

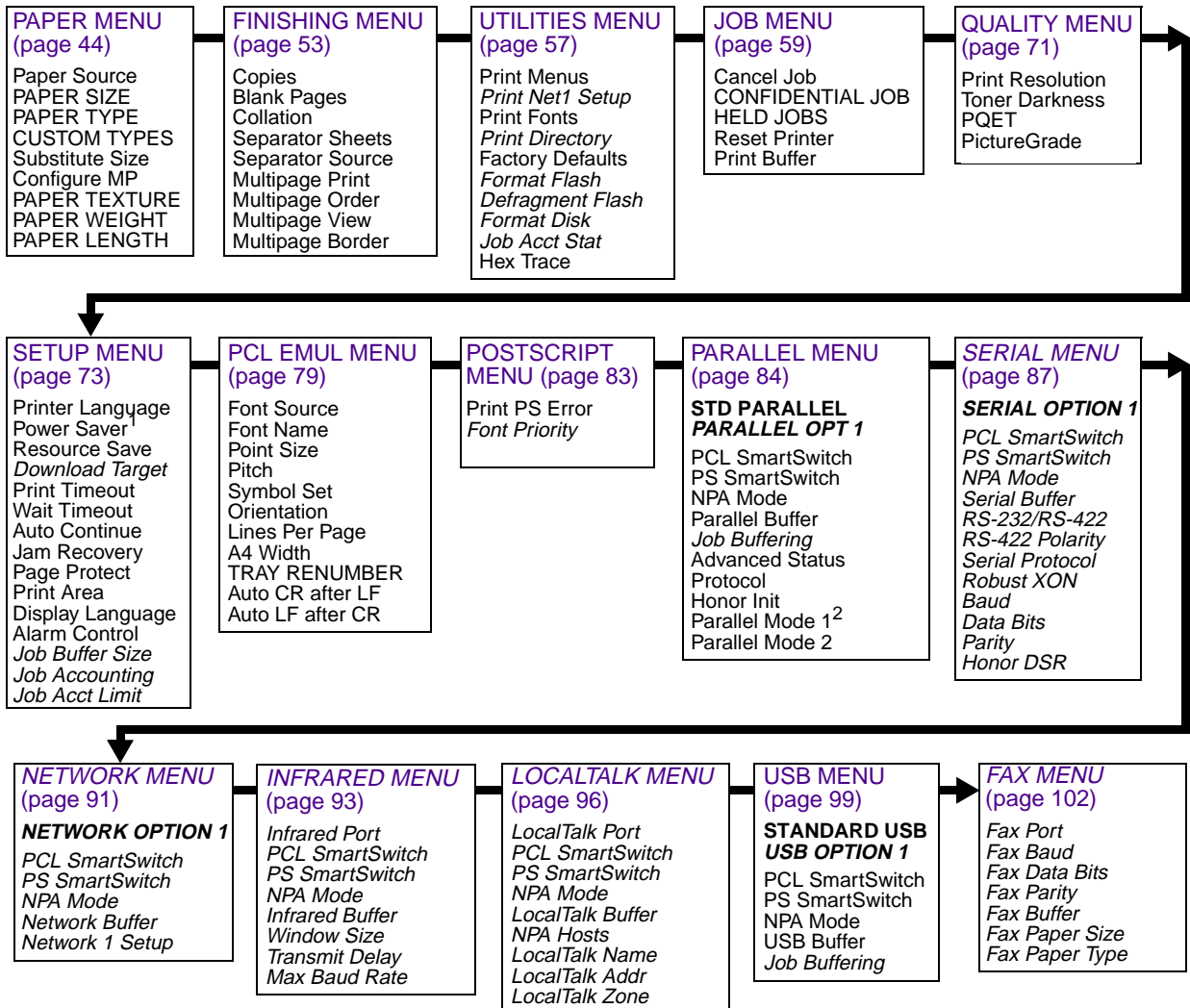

¹ Some printer models released in the year 2000 or later designated as Energy Star printers cannot have Power Saver disabled.

² Parallel Mode 1 is not supported on the Opra M412 printer.

For all menus:

- Press **Menu**> or <**Menu** to enter the menus and scroll through the options.
- Press **Select** to choose a menu, menu item, or value.
- Press **Return** to back up to the previous menu level.

For all menu except CONFIG MENU:

- Press **Go** to return to **Ready**.

CONFIG MENU (page 106)

Prt Quality Pgs
Panel Menus
Buffered Jobs
Factory Defaults
NARROW MEDIA
Exit Config Menu

Paper Menu

Use the PAPER MENU to define all settings relating to print material input and output, as well as the specific print material you are using with your printer.

Paper Menu

Menu Item	Values
Paper Source	<p>Tray 1* Tray 2 MP Feeder Manual Paper Manual Env</p> <hr/> <p>The Paper Source setting identifies the default paper source.</p> <p>Tray 2 is available only if the optional 500-sheet drawer is installed. See “Optional 500-Sheet Drawer” on page 223 for more information.</p> <p>Select Manual Paper when manually feeding a sheet of print material other than an envelope through the multipurpose feeder.</p> <p>Select Manual Env when manually feeding an envelope through the multipurpose feeder.</p> <p>MP Feeder displays only if Configure MP is set to Cassette. If Paper Source is set to MP Feeder and Configure MP is set to First, the Paper Source setting automatically changes to Tray 1.</p> <p>If you are using the same size and type of print material in two paper sources (and the Paper Size and Paper Type settings are correctly set), the trays are automatically linked. When one paper source is empty, print material automatically feeds from the other paper source. See “Tray Linking” on page 135 for more information.</p>
*Factory default	

Paper Menu (continued)

Menu Item	Values
PAPER SIZE	Tray 1 Size Tray 2 Size Each of the above menu items support the following values as a second menu: A4* (Country specific) JIS B5 Letter* (Country specific) Legal Executive MP Feeder Size A4* (Country specific) A5 JIS B5 Letter* (Country specific) Legal Executive Universal 7 ¼ Envelope 9 Envelope 10 Envelope DL Envelope C5 Envelope B5 Envelope Other Envelope
*Factory default	

Paper Menu (continued)

Menu Item	Values
PAPER SIZE (continued)	<p>Manual Pap Size</p> <ul style="list-style-type: none"> A4* (Country specific) A5 JIS B5 Letter* (Country specific) Legal Executive Universal <p>Manual Env Size</p> <ul style="list-style-type: none"> 7 ¾ Envelope 9 Envelope 10 Envelope* (Country specific) DL Envelope* (Country specific) C5 Envelope B5 Envelope Other Envelope <hr/> <p>The PAPER SIZE setting identifies the default formatting size for each paper source. See the tables beginning on page 116 for a list of the dimensions for each paper and envelope size.</p> <p>Note: Before loading print material in any paper source, make sure you select the PAPER SIZE, PAPER TYPE, PAPER TEXTURE, PAPER WEIGHT, and PAPER LENGTH from the operator panel for the paper source. Also, select the paper size and type from your software application for the print material you are loading.</p> <p>Select Manual Pap Size when manually feeding a single sheet of print material other than an envelope through the multipurpose feeder.</p> <p>Select Manual Env Size when manually feeding a single envelope through the multipurpose feeder.</p> <p>Universal refers to any size that is not considered a standard size. Select Universal from the PAPER SIZE menu when you load print material that does not match any of the other available sizes. The printer automatically formats the page for the maximum possible size. You can then set the actual page size from your application.</p> <p>Select Other Envelope from the PAPER SIZE menu when you load envelopes that do not match any of the other available sizes. The printer automatically formats for the maximum possible envelope size. You can then set the actual envelope size from your application.</p>
<p>*Factory default</p>	

Paper Menu (continued)

Menu Item	Values
PAPER TYPE	<p>Tray 1 Type Tray 2 Type Manual Pap Type</p> <p>Each of the above menu items support the following values as a second menu:</p> <ul style="list-style-type: none"> Plain Paper* Card Stock Transparency Labels Bond Letterhead Preprinted Colored Paper Custom Type 1 Custom Type 2* Custom Type 3 Custom Type 4 Custom Type 5 Custom Type 6 <p>Note: Plain Paper is the default setting for Tray 1 Type and Manual Pap Type. Custom Type 2 is the default for Tray 2 Type.</p> <p>MP Feeder Type</p> <ul style="list-style-type: none"> Plain Paper Card Stock Transparency Labels Bond Envelope Letterhead Preprinted Colored Paper Custom Type 1 Custom Type 2 Custom Type 3 Custom Type 4 Custom Type 5 Custom Type 6*
*Factory default	

Paper Menu (continued)

Menu Item	Values
PAPER TYPE (continued)	<p>Manual Env Type</p> <ul style="list-style-type: none"> Envelope* Custom Type 1 Custom Type 2 Custom Type 3 Custom Type 4 Custom Type 5 Custom Type 6 <hr/> <p>The PAPER TYPE setting lets you specify the type of print material installed in each paper source. This setting is used by the printer in the following ways:</p> <ul style="list-style-type: none"> • Enables the printer to optimize print quality for the specified print material. • Enables you to select paper sources through your software application by selecting only a type and size. A source selection is unnecessary. • Enables the printer to automatically link paper sources. Any sources that contain the same type and size of print material are automatically linked by the printer if you have set the PAPER SIZE and the PAPER TYPE to the correct settings for the paper sources. See “Tray Linking” on page 135 for more information. <p>Select Manual Pap Type when manually feeding a single sheet of print material through the multipurpose feeder.</p> <p>Select Manual Env Type when manually feeding an envelope through the multipurpose feeder.</p> <p>Note: Before loading print material in any paper source, make sure you select the PAPER SIZE, PAPER TYPE, PAPER TEXTURE, PAPER WEIGHT, and PAPER LENGTH from the operator panel for the paper source. Also, select the paper size and the type from your application for the print material you are loading.</p> <p>Custom Type 1 through 6 refers to special types of print materials. You can change the names through a utility, such as MarkVision. For more information on setting the Custom Type names, see CUSTOM TYPES on page 49.</p> <p>If you are using different print material in the paper sources, each source with a different print material must have the PAPER SIZE and PAPER TYPE set to a unique value to disable the automatic tray linking feature. Otherwise, if a paper source becomes empty, the printer selects print material from another source since the printer sees the trays as linked. This might cause a one-page letter to print on a sheet of labels or on a transparency. See “Tray Linking” on page 135 for more information.</p>
*Factory default	

Paper Menu (continued)

Menu Item	Values
CUSTOM TYPES	<p>Custom Type x (where x represents a custom type from 1 to 6)</p> <p>Paper* Card Stock Transparency Labels Envelope</p> <hr/> <p>The CUSTOM TYPES setting identifies the kind of print material used for each of the Custom Types available in the PAPER TYPE menu item. This print material designation optimizes print quality settings when you select print material from a paper source when the type is set to Custom Type x. If a user-defined name is available, the name displays instead of Custom Type x, where x represents a number 1 through 6. The user-defined name is truncated to 14 characters.</p>
Substitute Size	<p>Off Letter/A4*</p> <hr/> <p>Select Letter/A4 to let the printer automatically print A4-size jobs on letter-size paper and letter-size jobs on A4-size paper, if the requested size is not currently installed in the paper source.</p>
Configure MP	<p>Cassette* Manual First</p> <hr/> <p>When the multipurpose feeder is set to Cassette and the PAPER SIZE and PAPER TYPE settings are set correctly, the printer treats the multipurpose feeder like any other paper source. If a print job requests a size print material that is only loaded in the multipurpose feeder, the printer selects the print material from the multipurpose feeder for the print job.</p> <p>Select Manual to manually feed single sheets of print material through the multipurpose feeder. The multipurpose feeder acts like a manual feed slot and you can feed only one sheet of print material through at a time.</p> <p>If you set Configure MP to First, the printer feeds print material from the multipurpose feeder until it is empty, regardless of the paper source or paper size requested for the job.</p>
*Factory default	

Paper Menu (continued)

Menu Item	Values
PAPER TEXTURE	<p>Plain Texture Card Stock Text Trnsprncy Text Labels Texture Bond Texture Envelope Texture Ltrhead Texture Preprint Texture Colored Texture Custom 1 Texture Custom 2 Texture Custom 3 Texture Custom 4 Texture Custom 5 Texture Custom 6 Texture</p> <p>Each of the above menu items support the following three values as a second menu:</p> <ul style="list-style-type: none"> • Smooth • Normal* • Rough <p>Note: Rough is the factory default for Bond Texture.</p> <hr/> <p>Select the appropriate PAPER TEXTURE value (Smooth, Normal, or Rough) for each PAPER TYPE, including the Custom Types, that you are using. Set the correct PAPER TEXTURE value for your print material to make sure characters print clearly, without dropouts or voids. If the characters on your printed page appear broken or poorly-formed, set PAPER TEXTURE to Rough. If characters on your printed page appear smeared, set PAPER TEXTURE to Smooth or Normal.</p> <p>The PAPER TEXTURE setting works in connection with the PAPER TYPE and PAPER WEIGHT settings. You may need to change those settings to optimize print quality for your specific print material.</p> <p>If a user-defined texture is available, its name displays as a value instead of Custom x Texture, where x represents a number 1 through 6. The user-defined name is truncated to 14 characters.</p>
*Factory default	

Paper Menu (continued)

Menu Item	Values
PAPER WEIGHT	<p>Plain Weight CardStock Weight Trnsprncy Weight Labels Weight Bond Weight Envelope Weight Ltrhead Weight Preprint Weight Colored Weight Custom 1 Weight Custom 2 Weight Custom 3 Weight Custom 4 Weight Custom 5 Weight Custom 6 Weight</p> <p>Each of the above menu items support the following three values as a second menu:</p> <ul style="list-style-type: none"> • Light • Normal* • Heavy <hr/> <p>Select the appropriate PAPER WEIGHT value (Light, Normal, or Heavy) for each PAPER TYPE, including the Custom Types, that you are using. Set the correct PAPER WEIGHT value for your print material to make sure the toner adheres properly to the page. If you have trouble with toner rubbing off the page, set PAPER WEIGHT to Heavy. If your printed pages are curling excessively, set PAPER WEIGHT to Normal or Light.</p> <p>The PAPER WEIGHT setting works in connection with the PAPER TYPE and PAPER TEXTURE settings. You may need to change those settings to optimize print quality for your specific print material.</p> <p>If a user-defined weight is available, its name displays as a value instead of Custom x Weight, where x represents a number 1 through 6. The user-defined name is truncated to 14 characters.</p>
*Factory default	

Paper Menu (continued)

Menu Item	Values
PAPER LENGTH	<p>Plain Length CardStock Length Trnsprncy Length Labels Length Bond Length Envelope Length Ltrhead Length Preprint Length Colored Length Custom 1 Length Custom 2 Length Custom 3 Length Custom 4 Length Custom 5 Length Custom 6 Length</p> <p>Each of the above menu items support the following values as a second menu:</p> <ul style="list-style-type: none"> • Short • Normal* <hr/> <p>Select the appropriate PAPER LENGTH value (Normal or Short) for each printer paper type. Set the PAPER LENGTH value to Short if your print material is 152.4 mm (6 in.) or less in length. Set the PAPER LENGTH value to Normal for all other print material.</p> <p>Print material 152.4 mm (6 in.) or less in length can only be fed through the multipurpose feeder and must exit to the rear output bin.</p> <p>Note: If PAPER LENGTH is set to Short and the rear output bin door is not open, your job will not print. See Open Rear Door on page 172 for more information.</p> <p>If a user-defined length is available, its name displays as a value instead of Custom x Length, where x represents a number 1 through 6. The user-defined name is truncated to 14 characters.</p>
*Factory default	

Finishing Menu

Use the FINISHING MENU to define all settings relating to printer output.

Finishing Menu

Menu Item	Values
Copies	<p>1*...999</p> <hr/> <p>The Copies setting determines the number of copies printed for each page. The printer does not automatically collate the copies. For example, if you send three pages to print and set Copies to 2, the printer prints page 1, page 1, page 2, page 2, page 3, page 3.</p> <p>For information about how to use the Copies setting with the Collation setting, see Collation as follows.</p>
Blank Pages	<p>Do Not Print* Print</p> <hr/> <p>Select Print to include application-generated blank pages with your print job.</p> <p>Select Do Not Print if you do not want the printer to print any application-generated blank pages that appear in your document.</p>
Collation	<p>Off* On</p> <hr/> <p>When Collation is set to Off, the printer prints each page of a job the number of times as specified by the Copies setting. For example, if you send three pages to print and set Copies to 2, the printer prints page 1, page 1, page 2, page 2, page 3, page 3.</p> <p>When Collation is set to On, the printer prints the entire job the number of times as specified by the Copies setting. For example, if you send three pages to print and set Copies to 2, the printer prints page 1, page 2, page 3, page 1, page 2, page 3.</p> <p>Many applications collate documents by repeatedly sending the file to the printer. As a result, the printer must process each print job until the correct number of copies has printed. This requires additional time since the printer must process the same pages over again. By using Collation, the printer processes the file only once, saves the file in printer memory, and prints the multiple copies. This saves processing time for the printer and for the application, and overall printing time may be reduced.</p> <p>For Collation to work effectively, your software application must recognize this printer feature and not send the job to the printer multiple times. Your application must also let you specify the number of copies needed <i>or</i> let you use the printer default setting for Copies.</p> <p>Select Collation from the operator panel or from the printer driver. For best results, select <i>Collated</i> in the printer driver and set the number of copies to one. In your application, select <i>Uncollated</i> (if the option is available) and then select the number of copies you want.</p> <p>If the job is complex or exceeds the memory capacity of your printer, you may receive a 37 Insufficient Collation Area message. Press Go to clear the message. The printer collates the remaining pages in memory. If you reset the printer, the printer discards the job. See 37 Insufficient Collation Area on page 160 for more information.</p>
*Factory default	

Finishing Menu (continued)

Menu Item	Values
Separator Sheets	<p>None* Between Copies Between Jobs Between Pages</p> <hr/> <p>You can have the printer insert blank separator sheets between jobs, between multiple copies of a job, or between each page of a job. Separator sheets are pulled from the source specified in the Separator Source menu item.</p> <p>Select Between Copies for multiple copy jobs. If Collation is set to Off, a blank page is inserted between sets of each printed page. If Collation is set to On, a blank page is inserted between each copy of the job.</p> <p>Select Between Jobs to insert a blank page after each print job. This may be helpful when several people are using the printer.</p> <p>Select Between Pages to insert a blank page between each page of a job. This is useful if you are printing transparencies and want to reduce static build-up when stacking transparencies in the output bin.</p>
Separator Source	<p>Tray 1* Tray 2 MP Feeder</p> <hr/> <p>If you are using separator sheets, Separator Source lets you specify the paper source that holds the separator sheets.</p> <p>Only installed paper sources display as values. You can only select MP Feeder as the separator source if Configure MP is set to Cassette. If Separator Source is set to MP Feeder and Configure MP is set to First, the Separator Source setting automatically changes to Tray 1. See "Configure MP" on page 49 for more information.</p>
Multipage Print	<p>Off* 2-Up 3-Up 4-Up 6-Up 9-Up 12-Up 16-Up</p> <hr/> <p>Use the Multipage Print (N-up) setting to print multiple page images on a single page. For example, 2-Up means two page images are printed on one page, 3-Up means three page images are printed on one page, and so forth.</p> <p>The printer uses the Multipage Order, Multipage View, and Multipage Border settings to determine the order and orientation of the page images and if a border is printed around each page image.</p> <p>Printer setting changes within a print job may affect the results you get when using Multipage Print.</p>
*Factory default	

Finishing Menu (continued)

Menu Item	Values																																																
Multipage Order	<p data-bbox="339 244 501 348">Horizontal* Vertical Rev Horizontal Rev Vertical</p> <hr data-bbox="339 378 629 383"/> <p data-bbox="339 392 1319 522">The Multipage Order setting determines the positioning of multiple page images on pages printed using Multipage Print. You may choose one of four different orders. The positioning of page images depends on if the pages are sent to the printer as portrait or landscape images. The following examples show the result of using each Multipage Order setting on a 4-Up print job.</p> <div data-bbox="439 531 1229 1156" style="display: flex; flex-wrap: wrap; justify-content: space-around;"> <div style="text-align: center; margin: 10px;"> <p>Horizontal</p> <table border="1" style="margin: 0 auto;"> <thead> <tr> <th colspan="2">Portrait</th> <th colspan="2">Landscape</th> </tr> </thead> <tbody> <tr> <td>Page 1</td> <td>Page 2</td> <td>Page 2</td> <td>Page 4</td> </tr> <tr> <td>Page 3</td> <td>Page 4</td> <td>Page 1</td> <td>Page 3</td> </tr> </tbody> </table> </div> <div style="text-align: center; margin: 10px;"> <p>Vertical</p> <table border="1" style="margin: 0 auto;"> <thead> <tr> <th colspan="2">Portrait</th> <th colspan="2">Landscape</th> </tr> </thead> <tbody> <tr> <td>Page 1</td> <td>Page 3</td> <td>Page 3</td> <td>Page 4</td> </tr> <tr> <td>Page 2</td> <td>Page 4</td> <td>Page 1</td> <td>Page 2</td> </tr> </tbody> </table> </div> <div style="text-align: center; margin: 10px;"> <p>Rev Horizontal</p> <table border="1" style="margin: 0 auto;"> <thead> <tr> <th colspan="2">Portrait</th> <th colspan="2">Landscape</th> </tr> </thead> <tbody> <tr> <td>Page 2</td> <td>Page 1</td> <td>Page 1</td> <td>Page 3</td> </tr> <tr> <td>Page 4</td> <td>Page 3</td> <td>Page 2</td> <td>Page 4</td> </tr> </tbody> </table> </div> <div style="text-align: center; margin: 10px;"> <p>Rev Vertical</p> <table border="1" style="margin: 0 auto;"> <thead> <tr> <th colspan="2">Portrait</th> <th colspan="2">Landscape</th> </tr> </thead> <tbody> <tr> <td>Page 3</td> <td>Page 1</td> <td>Page 1</td> <td>Page 2</td> </tr> <tr> <td>Page 4</td> <td>Page 2</td> <td>Page 3</td> <td>Page 4</td> </tr> </tbody> </table> </div> </div>	Portrait		Landscape		Page 1	Page 2	Page 2	Page 4	Page 3	Page 4	Page 1	Page 3	Portrait		Landscape		Page 1	Page 3	Page 3	Page 4	Page 2	Page 4	Page 1	Page 2	Portrait		Landscape		Page 2	Page 1	Page 1	Page 3	Page 4	Page 3	Page 2	Page 4	Portrait		Landscape		Page 3	Page 1	Page 1	Page 2	Page 4	Page 2	Page 3	Page 4
Portrait		Landscape																																															
Page 1	Page 2	Page 2	Page 4																																														
Page 3	Page 4	Page 1	Page 3																																														
Portrait		Landscape																																															
Page 1	Page 3	Page 3	Page 4																																														
Page 2	Page 4	Page 1	Page 2																																														
Portrait		Landscape																																															
Page 2	Page 1	Page 1	Page 3																																														
Page 4	Page 3	Page 2	Page 4																																														
Portrait		Landscape																																															
Page 3	Page 1	Page 1	Page 2																																														
Page 4	Page 2	Page 3	Page 4																																														
*Factory default																																																	

Finishing Menu (continued)

Menu Item	Values
Multipage View	<p>Auto* Long Edge Short Edge</p> <hr/> <p>Use the Multipage View setting to select the orientation of the printed page with respect to the page images during Multipage Print.</p> <p>Select Auto to allow the printer to choose between portrait and landscape positioning.</p> <p>Select Long Edge to position the long edge of the print material as the top of the page.</p> <p>Select Short Edge to position the short edge of the print material as the top of the page.</p> <p>Note: For PostScript 3 emulation print jobs, the Auto setting is always in portrait orientation.</p>
Multipage Border	<p>None* Solid</p> <hr/> <p>Use the Multipage Border setting to specify if a border is printed around each page image during Multipage Print.</p> <p>Select None if you do not want to print a border around each page image.</p> <p>Select Solid to print a solid line border around each page image.</p>
*Factory default	

Utilities Menu

Use the UTILITIES MENU to print a variety of listings relating to available printer resources, printer settings, and print jobs. Additional menu items let you set up printer hardware and troubleshoot printer problems.

Utilities Menu

Menu Item	Values
Print Menu	<p>Press Select to print the menu settings page.</p> <p>The menu settings page is a list of the user default settings, the installed options, and the amount of available printer memory. This list also shows you the order of menu items.</p> <p>Note: The menu settings page must be printed on letter-, legal-, or A4-size paper.</p>
Print Net1 Setup	<p>Press Select to print the internal print server settings page.</p> <p>The internal print server settings page contains information on your network setup and the printer settings for your network as defined by the Network 1 Setup menu item in the NETWORK MENU. See “Network 1 Setup” on page 92 for more information.</p> <p>Note: Print Net1 Setup displays only if an internal print server is installed in your printer.</p>
Print Fonts	<p>PCL Fonts PS Fonts</p> <hr/> <p>Press Select to print a font sample list that shows all the fonts currently available in the selected printer language, PCL Fonts or PS Fonts. For more information, see “Printing a Font Sample List” on page 242.</p>
Print Directory	<p>Press Select to print a list of all the resources stored in flash memory or on the hard disk option.</p> <p>The Print Directory menu item is available only if at least one of the options is installed and formatted. Refer to the <i>Technical Reference</i> for details.</p>
Factory Defaults	<p>Restore Do Not Restore</p> <hr/> <p>If you choose Restore:</p> <ul style="list-style-type: none">• All downloaded resources (fonts, macros, symbol sets) in printer memory (RAM) are deleted. (Resources residing in flash memory or on the hard disk option are unaffected.)• All menu settings are returned to the factory default values except:<ul style="list-style-type: none">– Display Language (SETUP MENU) which is the operator panel display language.– All settings in the PARALLEL MENU, SERIAL MENU, NETWORK MENU, INFRARED MENU, LOCAL TALK MENU, USB MENU, and FAX MENU. <p>The message Restoring Factory Defaults briefly appears while the printer restores the factory default settings. See Restoring Factory Defaults on page 157 for more information.</p>

Utilities Menu (continued)

Menu Item	Values
Format Flash	<p>Yes No</p> <hr/> <p>Formatting the flash memory option deletes all resources (fonts, macros, symbol sets) stored in flash memory and prepares the flash memory card to receive new resources.</p> <p>The Format Flash menu item only displays if the installed flash memory option is <i>not</i> defective or Read/Write or Write protected. 51 Defective Flash may display when the printer is turned on, or during flash format and write operations. See 51 Defective Flash on page 161 for more information.</p> <p>Warning: If you select Format Flash and press Go, any data stored in flash memory is lost. <i>Do not turn off the printer while the flash is formatting.</i></p>
Defragment Flash	<p>Yes No</p> <hr/> <p>Defragmenting the flash memory option transfers all undeleted resources stored in flash memory to printer memory and then reformats the flash memory option. When the format operation is complete, the undeleted resources are loaded back into flash memory.</p> <p>The Defragment Flash menu item only displays if the installed flash memory option is <i>not</i> defective or Read/Write or Write protected. 51 Defective Flash may display when the printer is turned on, or during flash format and write operations. See 51 Defective Flash on page 161 for more information.</p> <p>37 Insufficient Defrag Memory displays if printer memory is too full to perform the Flash Memory Defragment operation. See 37 Insufficient Defrag Memory on page 160 for more information.</p> <p>Warning: <i>Do not turn off the printer while the flash is defragmenting.</i></p>
Format Disk	<p>Yes No</p> <hr/> <p>Formatting the hard disk option deletes all resources stored on the hard disk and prepares it to receive new resources.</p> <p>The Format Disk menu item only displays if the installed hard disk option is <i>not</i> defective or Read/Write or Write protected. 61 Defective Disk may display when the printer is turned on, or during disk format and write operations. See 61 Defective Disk on page 165 for more information.</p> <p>Format Disk does <i>not</i> display if Job Buffer Size is set to 100%. See Job Buffer Size on page 77 for more information.</p> <p>Warning: If you select Format Disk and press Go, any data stored on the hard disk option is lost. <i>Do not turn off the printer while the hard disk is formatting.</i></p>

Utilities Menu (continued)

Menu Item	Values
Job Acct Stat	<p>Print Clear</p> <hr/> <p>The Job Acct Stat menu item only displays if a hard disk option is installed in your printer and is <i>not</i> defective or Read/Write or Write protected. Job Accounting in the SETUP MENU must be set to On.</p> <p>Select Print to print a list of statistics for a defined number of the most recent print jobs. (The number of jobs is determined by the value of the Job Acct Limit menu item in the SETUP MENU). The statistics include if the job printed with or without errors, the time required to print the job, the size (in bytes) of the job, the requested paper size and paper type, the total number of printed pages, and the number of copies requested.</p> <p>Select Clear to delete all accumulated job statistics from the hard disk option. Clearing Job Accounting Stat displays until the process completes. See Clearing Job Accounting Stat on page 152 for more information.</p>
Hex Trace	<p>Press Select to enter Hex Trace mode.</p> <p>Hex Trace helps isolate the source of a print job problem. With Hex Trace selected, all data sent to the printer is printed in hexadecimal and character representation. Control codes are not run.</p> <p>To exit Hex Trace, turn the printer power Off (O), or reset the printer. To reset the printer, press Menu> or <Menu. JOB MENU displays. Press Menu> or <Menu until Reset Printer appears on the second line of the operator panel display. Press Select.</p> <p>Note: Resetting the printer deletes all current data from the print buffer, including all Print and Hold jobs. See Reset Printer on page 70 for more information.</p>

Job Menu

Some JOB MENU menu items are available when the printer displays the **Ready** message and is idle since it is not accepting, formatting, or printing a job. Other menu items in JOB MENU are only available when the printer is busy processing or printing a job, when a printer message other than **Ready** displays, or when the printer is in **Hex Trace** mode.

Note: For documentation purposes, *Print and Hold jobs* refers to any of the following jobs: Confidential Job, Reserve Print Job, Repeat Print Job, and Verify Print Job. See page 108 for more information on Print and Hold jobs.

Job Menu

Menu Item	Values
Cancel Job	Press Select to cancel the current print job. Cancel Job displays only when the printer is processing a print job.
<p>CONFIDENTIAL JOB</p> <p>This menu item is <i>not</i> displayed in the JOB MENU until the printer has processed at least one Confidential Job.</p> <p>Note: Use your software application or printer driver to create and send a Confidential Job.</p>	<p>Enter PIN</p> <p>Once a correct Personal Identification Number (PIN) is entered, the following values are available as second and third sub-menus. See “Entering a Personal Identification Number (PIN)” on page 111 for more information.</p> <p>Print All Jobs</p> <p>PRINT A JOB</p> <p><Job #1 Username> <Job #1 Jobname> <Job #2 Username> <Job #2 Jobname> <Job #3 Username> <Job #3 Jobname> ... <Job #n Username> <Job #n Jobname></p> <p>Delete All Jobs</p> <p>DELETE A JOB</p> <p><Job #1 Username> <Job #1 Jobname> <Job #2 Username> <Job #2 Jobname> <Job #3 Username> <Job #3 Jobname> ... <Job #n Username> <Job #n Jobname></p> <p>PRINT COPIES</p> <p><Job #1 Username> <Job #1 Jobname> <Job #2 Username> <Job #2 Jobname> <Job #3 Username> <Job #3 Jobname> ... <Job #n Username> <Job #n Jobname></p> <p>Note: In the sub-menu values listed above, the Username field is based on the username field in your driver. By default, this is the user name or user ID you type to log on to your operating system. You can change the name in this field to another name in the driver before you send the job. The Jobname field contains a title name for your file as defined by your application software when the job was sent. You cannot change this field. If one or both of the fields is empty, the name was not defined by the application. For example, if your last name is Smith and your file is called timesheet, the operator panel may display smith timesheet. The Username and Jobname fields are truncated to 16 characters.</p> <hr/> <p>When you create a Confidential Job, the printer formats your job and holds the job in memory. The printer delays the printing of your job until you enter a PIN assigned to the job. You enter the number through the operator panel. See “Entering a Personal Identification Number (PIN)” on page 111 for more information.</p>

Job Menu (continued)

Menu Item	Values
CONFIDENTIAL JOB (continued)	<p>Once a valid PIN is entered, the operator panel displays:</p> <div data-bbox="344 288 636 380" style="border: 2px solid black; padding: 5px;"><p>CONFIDENTIAL JOB Print All Jobs</p></div> <p>You have several print or delete options to choose from:</p> <ul style="list-style-type: none">• print all jobs• print a job• print copies• delete all jobs• delete a job <p>Press Menu> or <Menu until the menu item you need appears on the second line of the display.</p> <p>Press Select.</p> <p>While in the values for this menu item, the following button actions are possible:</p> <ul style="list-style-type: none">• Press Go to exit the selection and the menu group, and return to the previous screen.• Press Menu> or <Menu to choose the next or previous option in the list.• Press Return to exit the operation, but remain in the JOB MENU or to return to the previous screen after scrolling through a list of print jobs. <p>Note: While in the CONFIDENTIAL JOB menu item, you can make selections in both PRINT A JOB and DELETE A JOB values. Then, both actions occur when you press Go to exit the JOB MENU.</p>

Job Menu (continued)

Menu Item	Values
CONFIDENTIAL JOB (continued)	<p>Print All Jobs</p> <p>If you press Select to choose this value, printing starts and the operator panel exits this operation.</p> <p>All Confidential Jobs associated with your assigned PIN are printed.</p> <p>The message Queuing Jobs displays. For more information, see “Queuing Jobs” on page 156.</p> <p>PRINT A JOB</p> <p>If you press Select to choose this value, a list of jobs available for printing is displayed. The first job is displayed on the second line.</p> <div data-bbox="344 557 798 638" style="border: 1px solid black; padding: 5px; margin: 10px 0;"> <p>PRINT A JOB <Job #1 Username> <Job #1 Jobname></p> </div> <p>All Confidential Jobs associated with your assigned PIN are listed. Use Menu> or <Menu to scroll through the list of available jobs.</p> <div data-bbox="344 734 798 815" style="border: 1px solid black; padding: 5px; margin: 10px 0;"> <p>PRINT A JOB <Job #2 Username> <Job #2 Jobname></p> </div> <p>See the note on page 60 for an explanation of Username and Jobname.</p> <p>Press Menu> or <Menu to scroll to the job you want to print. When the job is on the second line of the display, press Select to mark the job for printing. An asterisk (*) appears to mark the job for printing. You may select additional jobs to print by marking them with an asterisk.</p> <p>Note: If you make a mistake and mark the wrong job, press Select again to unmark the job. The asterisk beside the print job is removed.</p> <p>When a job has been marked for printing, the job is removed from the list of available print jobs in the DELETE A JOB list. See DELETE A JOB on page 63 for more information.</p> <p>Press Return until you exit the menus or press Go to exit the menus. The message Queuing Jobs displays; however, the message Queuing and Deleting Jobs displays if you previously selected some print jobs for deletion. Once the printer exits the menus and returns to an online state, the job starts printing. For more information, see Queuing Jobs and Queuing and Deleting Jobs on page 156.</p>

Job Menu (continued)

Menu Item	Values
CONFIDENTIAL JOB (continued)	<p>Delete All Jobs</p> <p>If you press Select to choose this value, the message Delete All Jobs. Go/Stop? displays. You have one chance to stop the deletion of all the confidential jobs associated with your PIN.</p> <p>Note: All Confidential Jobs associated with your assigned PIN are deleted.</p> <p>Press Stop if you do not want to delete all jobs. The operator panel returns to the following screen, and you may choose to exit the CONFIDENTIAL JOB menu item or scroll to another value using Menu> or <Menu.</p> <div data-bbox="344 479 636 571" style="border: 2px solid black; padding: 5px; margin: 10px 0;"> <p>CONFIDENTIAL JOB Delete All Jobs</p> </div> <p>Press Go to delete all jobs. The message Deleting Jobs displays. The jobs are deleted and the printer exits the menus.</p> <p>DELETE A JOB</p> <p>If you press Select to choose this value, a list of jobs held in printer memory is displayed as shown. The first job is displayed on the second line.</p> <div data-bbox="344 762 798 843" style="border: 2px solid black; padding: 5px; margin: 10px 0;"> <p>DELETE A JOB <Job #1 Username> <Job #1 Jobname></p> </div> <p>All Confidential Jobs associated with your assigned PIN are listed. Use Menu> or <Menu to scroll through the list of available jobs.</p> <div data-bbox="344 939 798 1020" style="border: 2px solid black; padding: 5px; margin: 10px 0;"> <p>DELETE A JOB <Job #2 Username> <Job #2 Jobname></p> </div> <p>See the note on page 60 for an explanation of Username and Jobname.</p> <p>Press Menu> or <Menu to scroll to the job you want to delete. When the job is on the second line of the display, press Select to mark a job for deletion. An asterisk (*) appears to mark the job for deletion. You may select additional jobs to delete by marking them with an asterisk.</p> <p>Note: If you make a mistake and mark the wrong job, press Select again to unmark the job. The asterisk beside the print job is removed.</p> <p>When a job has been marked for deletion, the job is removed from the list of available print jobs in the PRINT A JOB list and the PRINT COPIES list. See PRINT A JOB on page 62 and PRINT COPIES on page 64 for more information.</p> <p>Press Return until you exit the menus or press Go to exit the menus. Once the printer exits the menus and returns to an online state, the jobs you selected are deleted. The message Deleting Jobs displays; however, the message Queuing and Deleting Jobs displays if you previously selected some jobs to print. For more information, see Deleting Jobs and Queuing and Deleting Jobs on page 153.</p>

Job Menu (continued)

Menu Item	Values
CONFIDENTIAL JOB (continued)	<p>PRINT COPIES</p> <p>If you press Select to choose this value, a list of jobs held in printer memory is displayed as shown. The first job is displayed on the second line.</p> <div data-bbox="344 354 798 439" style="border: 2px solid black; padding: 5px;"> <p>PRINT COPIES <Job #1 Username> <Job #1 Jobname></p> </div> <p>All Confidential Jobs associated with your assigned PIN are listed. Use Menu> or <Menu to scroll through the list of available jobs.</p> <div data-bbox="344 531 798 616" style="border: 2px solid black; padding: 5px;"> <p>PRINT COPIES <Job #2 Username> <Job #2 Jobname></p> </div> <p>See the note on page 60 for an explanation of Username and Jobname.</p> <p>You may select one or more jobs to print and you may change the number of copies for each job to be printed.</p> <p>Press Menu> or <Menu to scroll to the one job you want to print. When the job is on the second line of the display, press Select.</p> <p>The following prompt displays:</p> <div data-bbox="344 843 632 939" style="border: 2px solid black; padding: 5px;"> <p>Copies =x*</p> </div> <p>The setting for the current number of copies is indicated by the asterisk (*). Press Menu> or <Menu to increase or decrease the number of copies as specified by the x value. You may choose to print from 1 to 999 copies of a single job at a time.</p> <p>Press Select to save the setting for the number of copies you need. The Saved message displays and then the list of jobs displays. An asterisk (*) appears beside the job name to indicate it is selected for printing. You may select other jobs to print and change the number of copies required.</p> <p>When a job has been marked for printing, the job is removed from the list of available print jobs in the DELETE A JOB list. See DELETE A JOB on page 63 for more information.</p> <p>When you finish making selections and change the number of copies, press Return until you exit the menus or press Go to exit the menus. The message Queuing Jobs displays; however, the message Queuing and Deleting Jobs displays if you previously selected some jobs for deletion. Once the printer exits the menus and returns to an online state, the remaining copies print. Once all copies are printed, the job is deleted from printer memory. For more information, see Queuing Jobs and Queuing and Deleting Jobs on page 156.</p>

Job Menu (continued)

Menu Item	Values
<p>HELD JOBS</p> <p>This menu item is <i>not</i> displayed in the JOB MENU until the printer has processed at least one Repeat Print, Reserve Print, or Verify Print job.</p> <p>Note: Use your software application or printer driver to create and send a Repeat Print, Reserve Print, or Verify Print job.</p>	<p>Print All Jobs</p> <p>PRINT A JOB</p> <p><Job #1 Username> <Job #1 Jobname> <Job #2 Username> <Job #2 Jobname> <Job #3 Username> <Job #3 Jobname> ... <Job #n Username> <Job #n Jobname></p> <p>Delete All Jobs</p> <p>DELETE A JOB</p> <p><Job #1 Username> <Job #1 Jobname> <Job #2 Username> <Job #2 Jobname> <Job #3 Username> <Job #3 Jobname> ... <Job #n Username> <Job #n Jobname></p> <p>PRINT COPIES</p> <p><Job #1 Username> <Job #1 Jobname> <Job #2 Username> <Job #2 Jobname> <Job #3 Username> <Job #3 Jobname> ... <Job #n Username> <Job #n Jobname></p> <p>Note: In the sub-menu values listed above, the Username field is based on the username field in your driver. By default, this is the user name or user ID you type in to log on to your operating system. You can change the name in this field to another name in the driver before you send the job. The Jobname field contains a title name for your file as defined by your application software when the job was sent. You cannot change this field. If one or both of the fields is empty, the name was not defined by the application. For example, if your last name is Smith and your file is called timesheet, the operator panel may display smith timesheet. The Username and Jobname fields are truncated to 16 characters.</p> <hr/> <p>Unlike a Confidential Job, you do not enter a PIN to access the values once you enter the HELD JOBS menu item.</p> <p>When you create a Repeat Print job, the job formats and prints, but the printer stores the job in memory so you can print additional copies of the job at a later time. As long as the job remains stored in memory, you may print additional copies. Repeat Jobs are automatically deleted when the printer requires extra memory to process additional jobs or when the number of Repeat Jobs stored exceeds the value of the set limit for Print and Hold Repeat Job Limit. For more information about this setting, refer to the <i>Technical Reference</i>.</p> <p>When you create a Reserve Print job, the job formats, but does not print. The printer stores the job in memory so you can print the job at a later time. All pages in the job are held in memory until you activate printing by using the operator panel to select Print All Jobs or PRINT A JOB. Reserve Print jobs are not deleted from memory when the job prints. To delete a Reserve Print job, you must request DELETE A JOB using the operator panel.</p>

Job Menu (continued)

Menu Item	Values
HELD JOBS (continued)	<p>When you create a Verify Print job, the job formats, and one copy of the job prints. Additional requested copies are held in printer memory. You specify the number of copies you want when you send the job from the printer driver. This allows you to examine the first copy to be sure it is satisfactory before you print the other copies.</p> <p>If the job is unsatisfactory, you would not want the other copies to print. Select the DELETE A JOB value, and select the job to delete it. See DELETE A JOB on page 68 for more information.</p> <p>To print the remaining copies, you can:</p> <ul style="list-style-type: none"> • Change the number of remaining copies to print. Select PRINT COPIES. Select the specific job. At the Copies prompt, change the number of copies to print from the number set in the printer driver and press Select. Press Return until you exit the menus or press Go to exit the menus. Once the printer exits the menus and returns to an online state, the remaining copies print. Once all copies are printed, the job is deleted from printer memory. For more information, see PRINT COPIES on page 69. • Print the number of copies set in the printer driver. Select PRINT A JOB. Select the specific job. The remaining copies print. Once all copies are printed, the job is deleted from printer memory. For more information, see PRINT A JOB on page 67. <p>Once you select HELD JOBS, the operator panel displays:</p> <div data-bbox="344 812 639 907" style="border: 2px solid black; padding: 5px; margin: 10px 0;"> <p>HELD JOBS Print All Jobs</p> </div> <p>You have several print or delete options to choose from:</p> <ul style="list-style-type: none"> • print all jobs • print a job • print copies • delete all jobs • delete a job <p>Press Menu> or <Menu until the menu item you need appears on the second line of the display.</p> <p>Press Select.</p> <p>While in the values for this menu item, the following button actions are possible:</p> <ul style="list-style-type: none"> • Press Go to exit the selection, the menu group, and return to the previous screen. • Press Menu> or <Menu to choose the next or previous option in the list. • Press Return to exit the operation, but remain in the JOB MENU or to return to the previous screen after scrolling through a list of print jobs. <p>Note: While in the HELD JOBS menu item, you can make selections in both PRINT A JOB and DELETE A JOB values. Then, both actions occur when you press Go to exit the JOB MENU.</p>

Job Menu (continued)

Menu Item	Values
HELD JOBS (continued)	<p>Print All Jobs</p> <p>If you press Select to choose this value, printing starts and the operator panel exits this operation.</p> <p>All Repeat Print, Reserve Print, and Verify Print jobs are printed.</p> <p>The message Queuing Jobs displays. For more information, see "Queuing Jobs" on page 156.</p> <p>PRINT A JOB</p> <p>If you press Select to choose this value, a list of jobs available for printing is displayed. The first job is displayed on the second line.</p> <div data-bbox="344 557 798 638" style="border: 1px solid black; padding: 5px; margin: 10px 0;"> <p>PRINT A JOB <Job #1 Username> <Job #1 Jobname></p> </div> <p>All Repeat Print, Reserve Print, and Verify Print jobs are listed. Use Menu> or <Menu to scroll through the list of available jobs.</p> <div data-bbox="344 734 798 815" style="border: 1px solid black; padding: 5px; margin: 10px 0;"> <p>PRINT A JOB <Job #2 Username> <Job #2 Jobname></p> </div> <p>See the note on page 65 for an explanation of Username and Jobname.</p> <p>Press Menu> or <Menu to scroll to the one job you want to print. When the job is on the second line of the display, press Select to mark a job for printing. An asterisk (*) appears to mark the job for printing. You may select additional jobs to print by marking them with an asterisk.</p> <p>Note: If you make a mistake and mark the wrong job, press Select again to unmark the job. The asterisk beside the print job is removed.</p> <p>When a job has been marked for printing, the job is removed from the list of available print jobs in the DELETE A JOB list. See DELETE A JOB on page 68 for more information.</p> <p>Press Return until you exit the menus or press Go to exit the menus. The message Queuing Jobs displays; however, the message Queuing and Deleting Jobs displays if you previously selected some jobs for deletion. Once the printer exits the menus and returns to an online state, the jobs you selected start printing. For more information, see Queuing Jobs and Queuing and Deleting Jobs on page 156.</p>

Job Menu (continued)

Menu Item	Values
HELD JOBS (continued)	<p>Delete All Jobs</p> <p>If you press Select to choose this value, the message Delete All Jobs. Go/Stop? displays so you have one chance to stop the deletion of all the print jobs you have sent.</p> <p>Note: All Repeat Print, Reserve Print, and Verify Print jobs will be deleted.</p> <p>Press Stop if you do not want to delete all jobs. The operator panel returns to the following screen, and you may choose to exit the CONFIDENTIAL JOB menu item or scroll to another value using Menu> or <Menu.</p> <div data-bbox="344 479 636 569" style="border: 2px solid black; padding: 5px; margin: 10px 0;"> <p>CONFIDENTIAL JOB Delete All Jobs</p> </div> <p>Press Go to delete all jobs. The message Deleting Jobs displays. The jobs are deleted and the printer exits the menus.</p> <p>DELETE A JOB</p> <p>If you press Select to choose this value, a list of jobs held in printer memory is displayed as shown. The first job is displayed on the second line.</p> <div data-bbox="344 762 798 843" style="border: 2px solid black; padding: 5px; margin: 10px 0;"> <p>DELETE A JOB <Job #1 Username> <Job #1 Jobname></p> </div> <p>All Repeat Print, Reserve Print, and Verify Print jobs are listed. Use Menu> or <Menu to scroll through the list of available jobs.</p> <div data-bbox="344 939 798 1020" style="border: 2px solid black; padding: 5px; margin: 10px 0;"> <p>DELETE A JOB <Job #2 Username> <Job #2 Jobname></p> </div> <p>See the note on page 65 for an explanation of Username and Jobname.</p> <p>Press Menu> or <Menu to scroll to the one job you want to delete. When the job you want to delete is on the second line of the display, press Select to mark a job for deletion. An asterisk (*) appears to mark the job for deletion. You may select additional jobs to delete by marking them with an asterisk.</p> <p>Note: If you make a mistake and mark the wrong job, press Select again to unmark the job. The asterisk beside the job is removed.</p> <p>When a job has been marked for deletion, the job is removed from the list of available jobs in the PRINT A JOB list and the PRINT COPIES list. See PRINT A JOB on page 67 and PRINT COPIES on page 69 for more information.</p> <p>Press Return until you exit the menus or press Go to exit the menus. Once the printer exits the menus and returns to an online state, the job is deleted. The message Deleting Jobs displays; however, the message Queuing and Deleting Jobs displays if you previously selected some jobs to print. For more information, see Deleting Jobs and Queuing and Deleting Jobs on page 153.</p>

Job Menu (continued)

Menu Item	Values
HELD JOBS (continued)	<p>PRINT COPIES</p> <p>If you press Select to choose this value, a list of jobs held in printer memory is displayed as shown. The first job is displayed on the second line.</p> <div data-bbox="344 354 798 435" style="border: 2px solid black; padding: 5px;"> <p>PRINT COPIES <Job #1 Username> <Job #1 Jobname></p> </div> <p>All Repeat Print, Reserve Print, and Verify Print jobs are listed. Use Menu> or <Menu to scroll through the list of available jobs.</p> <div data-bbox="344 531 798 612" style="border: 2px solid black; padding: 5px;"> <p>PRINT COPIES <Job #2 Username> <Job #2 Jobname></p> </div> <p>See the note on page 65 for an explanation of Username and Jobname.</p> <p>You may select one or more jobs to print and you may change the number of copies for each job to be printed.</p> <p>Press Menu> or <Menu to scroll to the job you want to print. When the job is on the second line of the display, press Select.</p> <p>The following prompt displays:</p> <div data-bbox="344 843 638 939" style="border: 2px solid black; padding: 5px;"> <p>Copies =x*</p> </div> <p>The setting for the current number of copies is indicated by the asterisk (*). Press Menu> or <Menu to increase or decrease the number of copies as specified by the x value. You may choose to print from 1 to 999 copies of a single job at a time.</p> <p>Note: You specify a certain number when you send a Verify Print Job. For more information, see “Verify Print Job” on page 110.</p> <p>Press Select to save the setting for the number of copies you need. The Saved message displays and then the list of jobs displays. There is now an asterisk beside the job name to indicate it is selected for printing. You may select other jobs to print and change the number of copies required.</p> <p>When a job has been marked for printing, the job is removed from the list of available jobs in the DELETE A JOB list. See DELETE A JOB on page 68 for more information.</p> <p>When you are finished making selections and changing the number of copies, press Return until you exit the menus or press Go to exit the menus. The message Queuing Jobs displays; however, the message Queuing and Deleting Jobs displays if you previously selected some jobs for deletion. Once the printer exits the menus and returns to an online state, the remaining copies print. For more information, see Queuing Jobs and Queuing and Deleting on page 156.</p>

Job Menu (continued)

Menu Item	Values
Reset Printer	<p>Press Select to reset the printer.</p> <p>Note: Before selecting Reset Printer, exit the software application you are using.</p> <p>When you select Reset Printer, the printer resets to the user default setting for each menu item. All downloaded resources (fonts, macros, symbol sets) in printer memory (RAM) are deleted. All data on the currently selected host interface is deleted from the interface link buffer. All Print and Hold jobs are deleted.</p>
Print Buffer	<p>Press Select to print any data stored in the print buffer.</p> <p>This menu item is only available when you enter the JOB MENU while the Waiting message is displayed. The Waiting state occurs if an incomplete job is sent to the printer or if an ASCII job is being printed. Examples include sending a print screen command from your host computer or copying a DOS file.</p>

Quality Menu

Use the QUALITY MENU to change settings affecting the quality of the printed characters and images.

Quality Menu

Menu Item	Values
Print Resolution	<p>300 dpi 600 dpi* 1200 Image Q</p> <hr/> <p>The Print Resolution setting defines the number of dots printed per inch (dpi). The higher the setting, the sharper the clarity of printed characters and graphics.</p> <p>If your print jobs are mostly text, select 600 dpi for the highest quality output. Select 1200 Image Q (1200 Image Quality) when your job contains bitmapped images, such as scanned photos or some business graphics, that will benefit from enhanced line screening.</p>
Toner Darkness	<p>1 2 3 4 5 6 7 8* 9 10</p> <hr/> <p>Use the Toner Darkness menu item to lighten or darken the image appearance in your print jobs and get the most from your toner supply.</p> <p>If you want finer line width, higher definition in graphics, and lighter gray-scale images, set Toner Darkness to 6 or 7.</p> <p>If you want a bolder line width, emphasis in graphics, or darker gray-scale images, set Toner Darkness to 9 or 10. Use the 10 value to emphasize line width, produce the boldest text, and the darkest images.</p> <p>If you want to help conserve the printer toner supply, use the 1 to 5 values.</p>
*Factory default	

Quality Menu (continued)

Menu Item	Values
Toner Darkness (continued)	<p>When you first enter Toner Darkness, the operator panel displays:</p> <div data-bbox="344 288 636 383" style="border: 2px solid black; padding: 5px; margin: 10px 0;"> <p>Toner Darkness =8 -.....v..+*</p> </div> <p>Notice the periods (.) displayed across the second line of the operator panel. Each period represents one of the numbers 1 through 10 from left to right. A symbol like a v or an arrow points to the location of the 8 value, which is the factory default.</p> <p>A minus sign (-) at the left end of the string of periods indicates you are scrolling to the lower numbers in the string. A plus sign (+) at the right end of the string of periods indicates you are scrolling to the higher numbers in the string. If you decide to change the setting to 6, for example, use <Menu to scroll back to the 6.</p> <div data-bbox="344 609 636 704" style="border: 2px solid black; padding: 5px; margin: 10px 0;"> <p>Toner Darkness =6 -.....v. ..+</p> </div> <p>As you scroll backward toward the minus sign (-) indicating lower numbers, notice the v or arrow symbol moves on the operator panel as you press the <Menu button. It now appears in place of the sixth period. Notice the numeral 6 displays next to the equal sign to indicate your selection. A vertical bar () indicates the factory default of 8. The vertical bar remains at 8 unless 8 is selected. Then, the arrow covers the vertical bar.</p> <p>Press Select to select 6 as your current setting. The Saved message displays.</p>
PQET	<p>Off On*</p> <hr/> <p>When printed characters appear to have jagged or uneven edges, set PQET (Print Quality Enhancement Technology) to On to improve the print quality of your text and make the characters appear smoother.</p>
PictureGrade	<p>Off On*</p> <hr/> <p>Use the PictureGrade™ menu item to improve the quality of gray-scale printing at 300 and 600 dpi resolutions in PostScript 3 emulation.</p> <p>If you select Off, the printer uses the standard screening parameters. If you select On, different default screening parameters are used to improve the print quality of graphics.</p>
*Factory default	

Setup Menu

Use the SETUP MENU to configure a variety of printer features.

Setup Menu

Menu Item	Values
Printer Language	<p>PCL Emulation*</p> <p>PS Emulation</p> <hr/> <p>The printer language defines how the computer communicates with the printer. Your computer uses printer languages, such as PCL emulation and PostScript 3 emulation, to send print data to the printer. Setting a printer language as the default does not prevent the software application from sending print jobs that use the other printer language.</p>
Power Saver	<p>Disabled</p> <p>1...120 (20*) [Optra M410]</p> <p>1...240 (15*) [Optra M412]</p> <hr/> <p>The Power Saver menu item lets you reduce power usage when the printer is idle by determining the length of time (in minutes) the printer waits after a job is printed before it goes to a reduced power state.</p> <p>If you have selected a Power Saver value, the Power Saver message replaces the Ready message and becomes the new printer default when the printer is in a Ready state. Both messages indicate the printer is ready to receive jobs.</p> <p>If your printer is in constant use, select a high setting, such as 120. Under most circumstances, this keeps the printer ready to print with minimum warm-up time. However, a high setting also uses more energy.</p> <p>Set Power Saver to 1 to put the printer in Power Saver mode one minute after it finishes a print job. This uses much less energy, but requires more warm-up time for the printer. If your printer shares an electrical circuit with room lighting and you notice lights flickering, you may want to set Power Saver to 1.</p> <p>If you want a balance between energy consumption and a shorter warm-up period, select a Power Saver value between 1 and 120 minutes or 1 and 240 minutes depending on your printer model.</p> <p>Note: Some printer models released in the year 2000 or later designated as Energy Star printers cannot have Power Saver disabled.</p>
Resource Save	<p>Off*</p> <p>On</p> <hr/> <p>The Resource Save setting determines what the printer does with downloaded resources, such as fonts and macros, if it receives a job that requires more memory than is available.</p> <p>If Resource Save is set to On, the printer retains all permanent downloaded resources for all printer languages during language changes and printer resets. If the printer runs out of memory, Memory Full appears on the operator panel display.</p> <p>If Resource Save is set to Off, the printer retains permanent downloaded resources only until memory is needed. Then it deletes those resources stored for the inactive printer language.</p>
*Factory default	

Setup Menu (continued)

Menu Item	Values
Download Target	<p>RAM* Flash Disk</p> <hr/> <p>The Download Target menu item specifies the storage location for downloaded resources, such as fonts and macros.</p> <p>Storing downloaded resources in flash memory or hard disk is permanent storage rather than the temporary storage that RAM provides. You can add resources to flash memory or to the hard disk until the option is full. Use your software application or the printer Toolkit to download resources to the printer.</p> <p>The Download Target menu item only displays if a formatted flash memory option or hard disk option is installed in the printer and is <i>not</i> defective or Read/Write or Write protected. 51 Defective Flash or 61 Defective Disk may display when the printer is turned on, or during format and write operations. See 51 Defective Flash on page 161 or 61 Defective Disk on page 165 for more information.</p> <p>Disk does <i>not</i> display for Download Target if Job Buffer Size is set to 100%. See Job Buffer Size on page 77 for more information.</p> <p>If neither option is installed, Download Target does <i>not</i> display and all downloaded resources are automatically stored in printer memory (RAM).</p>
Print Timeout	<p>Disabled 1...255 (90*)</p> <hr/> <p>The Print Timeout setting determines the time (in seconds) the printer waits before printing the last page of a print job that does not end with a command to print the page. The print timeout counter does not start until the Waiting message displays.</p> <p>When a print timeout occurs, the printer stores the page in the print buffer.</p> <p>Select Disabled to turn Print Timeout off. When Print Timeout is disabled, the printer does not print the last page of a print job until one of the following occurs:</p> <ul style="list-style-type: none"> • The printer receives enough information to fill the page. • The printer receives a Form Feed command. • You select Print Buffer from the JOB MENU. See page 70 for more information.
Wait Timeout	<p>Disabled 15...65535 (40*)</p> <hr/> <p>The Wait Timeout setting determines the amount of time (in seconds) the printer waits to receive additional bytes of data from the computer. When this timeout expires, the print job is canceled.</p> <p>Select Disabled to turn Wait Timeout off.</p> <p>Wait Timeout is only available when using PostScript 3 emulation. The setting has no effect on PCL emulation print jobs.</p>
*Factory default	

Setup Menu (continued)

Menu Item	Values
Auto Continue	<p>Disabled* 5...255</p> <hr/> <p>Set Auto Continue to a value between 5 seconds and 255 seconds to have the printer continue printing after it detects one of the following errors:</p> <ul style="list-style-type: none"> 34 Short Paper 35 Res Save Off Deficient Memory 37 Insufficient Collation Area 37 Insufficient Defrag Memory 37 Insufficient Memory 38 Memory Full 39 Complex Page 51 Defective Flash 52 Flash Full 53 Unformatted Flash 54 Serial Option 1 Error 54 Std Par ENA Connection Lost 54 Par 1 ENA Connection Lost 54 Ser 1 Fax Connection Lost 54 Network 1 Software Error 55 Insufficient Fax Buffer 56 Serial Port 1 Disabled 56 Std Parallel Port Disabled 56 Parallel Port 1 Disabled 58 Too Many Flash Options 61 Defective Disk 62 Disk Full 63 Unformatted Disk Print Jobs on Disk? Go/Stop? <p>If one of these errors occurs and Auto Continue is set to Disabled, the printer stops and waits for operator intervention. When Auto Continue is set to a numerical value, the printer waits for the specified length of time and then automatically resumes processing.</p> <p>This setting is also used as a timer. After an inactive period in the menus, the printer automatically exits the menus and returns to the Ready state.</p>
Jam Recovery	<p>On Off Auto*</p> <hr/> <p>When Jam Recovery is set to Off, the printer does not reprint a page that has jammed.</p> <p>When Jam Recovery is set to On, the printer keeps the image for a printed page until the printer signals that the page has successfully exited the printer. The printer reprints all jammed pages.</p> <p>If Jam Recovery is set to Auto, the printer keeps the image and reprints the page unless the memory required to hold the page is needed for other printer tasks.</p>
*Factory default	

Setup Menu (continued)

Menu Item	Values
Page Protect	<p>Off* On</p> <hr/> <p>Set Page Protect to On to make sure an entire page is processed before it is printed. This may be helpful if you are having trouble printing a page properly because of complex page errors. If you still cannot print the page, your printer may not have enough memory to process the page. You may have to reduce the size and number of fonts on the page, or increase the installed printer memory.</p> <p>For most print jobs, you do not need to set Page Protect to On. When Page Protect is set to On, printing may be slowed.</p>
Print Area	<p>Normal* Whole Page</p> <hr/> <p>The Print Area setting lets you modify the PCL formatting area and the printer physical print area. Refer to the <i>Technical Reference</i> for more information about printable areas.</p>
Display Language	<p>English* French German Italian Spanish Danish Norwegian Dutch Swedish Portuguese Finnish</p> <p>The following languages appear as a menu item value on some operator panels:</p> <p>Japanese Russian Polish Hungarian Turkish Czech</p> <hr/> <p>The Display Language setting determines the language of the text that appears on the operator panel display.</p>
*Factory default	

Setup Menu (continued)

Menu Item	Values
Alarm Control	<p>Off Single* Continuous</p> <hr/> <p>If you want the printer alarm to sound any time the printer requires intervention, select Single or Continuous. If you select Single, the printer sounds three quick beeps to let you know operator intervention is required. If you select Continuous, the printer repeats the three beeps every ten seconds.</p> <p>Select Off if you do not want the alarm to sound.</p>
Job Buffer Size	<p>Disabled* 10...100%</p> <hr/> <p>If you have a hard disk option installed in your printer, you can allocate a portion of the available hard disk space for processing print jobs. The job is temporarily stored on the hard disk before being printed, usually freeing the host computer while the job prints.</p> <p>The Job Buffer Size menu item lets you select the amount of hard disk space allocated to job buffering for all ports that have Job Buffering set to On. You can choose any 1% increment between 10% and 100%. You must select a Job Buffer Size before you can set the Job Buffering menu item On in the PARALLEL MENU or USB MENU. See Job Buffering on page 85 and on page 101 for more information.</p> <p>The Job Buffer Size menu item only displays if the installed hard disk option is formatted and is <i>not</i> defective or Read/Write or Write protected. 61 Defective Disk may display when the printer is turned on, or during disk format and write operations. See 61 Defective Disk on page 165 for more information.</p> <p>To password protect the hard disk option and use Job Buffering simultaneously, perform the following steps in order:</p> <ul style="list-style-type: none"> • Set the Job Buffer Size for the hard disk option. • Download the files you want to the hard disk option. • Password protect the disk. <p>Refer to the <i>Technical Reference</i> for detailed information on how to password protect the hard disk option.</p> <p>Warning: If you change the job buffer size, the printer formats the hard disk, and all resources stored on the disk are deleted.</p>
*Factory default	

Setup Menu (continued)

Menu Item	Values
Job Accounting	<p>Off* On</p> <hr/> <p>If Job Accounting is set to On, the installed hard disk option stores statistical information about the most recent printer jobs. The statistics include whether the job printed with or without errors, the time required to print the job, the size (in bytes) of the job, the requested paper size and paper type, the total number of printed pages, and the number of copies requested.</p> <p>To print a listing of all the accumulated statistics, select Print from the Job Acct Stat menu item in the UTILITIES MENU. See Job Acct Stat on page 59 for more information.</p> <p>The Job Accounting menu item does <i>not</i> display if the installed disk option is defective or Read/Write or Write protected, or if Job Buffer Size is set to 100%. See Job Buffer Size on page 77 for more information.</p>
Job Acct Limit	<p>Disabled 10...1000* (in increments of 1 job)</p> <hr/> <p>If a hard disk option is installed in your printer, you can use the hard disk to store statistical information about a specified number of jobs. The value you select from the Job Acct Limit menu item determines the number of jobs for which statistics are stored. Once you reach the job limit, statistics for the oldest job are deleted as new statistics are stored, maintaining statistics for the specified number of jobs.</p> <p>If you select Disabled, the number of jobs for which statistics are stored is limited to the memory available on the hard disk.</p> <p>The Job Acct Limit menu item does <i>not</i> display if the installed hard disk option is defective or Read/Write or Write protected, or if Job Buffer Size is set to 100%. See Job Buffer Size on page 77 for more information.</p> <p>Warning: When you change the Job Acct Limit value, all statistical information stored on the disk option is discarded.</p>
*Factory default	

PCL Emul Menu

Use the PCL EMUL MENU to change printer settings that only affect jobs printed using the PCL emulation printer language.

PCL Emul Menu

Menu Item	Values
Font Source	<p>Resident* Download Flash Disk All</p> <hr/> <p>The Font Source setting determines which fonts appear in the Font Name menu. If a font source is not installed or does not contain any fonts, it is not listed as a value. Fonts are loaded and stored on the flash memory option. See "Understanding Fonts" on page 231 for more information.</p>
Font Name	<p>Font position and font name for all fonts in the selected font source (displays on both lines of the operator panel) (R0 Courier*)</p> <hr/> <p>After you select a font source, choose the specific font from the Font Name menu item. The printer displays the font source abbreviation, font ID, and font name for each font. The font source abbreviation is R for resident, F for flash, K for disk, and D for download. Note: Always select the correct Font Source before you select the Font Name. To print a font sample list showing all the fonts available for PCL emulation, see "Printing a Font Sample List" on page 242.</p>
Point Size (only displays for PostScript or typographic fonts)	<p>1...1008 (in increments of 0.25) (12*)</p> <hr/> <p><i>Point size</i> refers to the height of the characters in the font. One point equals approximately 1/72 of an inch. If you chose a scalable typographic font, you can select the point size for the font. You can select point sizes from 1 to 1008 in increments of 0.25 points. See "Pitch and Point Size" on page 232 for more information.</p>
*Factory default	

PCL Emul Menu (continued)

Menu Item	Values
Pitch (only displays for fixed or monospaced fonts)	<p>0.08...100 (in increments of 0.01) (10*)</p> <hr/> <p><i>Pitch</i> refers to the number of fixed-space characters in a horizontal inch of type.</p> <p>If you chose a scalable monospaced font, you can select the font pitch. You can select a pitch from 0.08 to 100 characters per inch (cpi) in increments of 0.01 cpi. For non-scalable monospaced fonts, the pitch displays, but it cannot be changed. See “Pitch and Point Size” on page 232 for more information.</p>
Symbol Set	<p>List of Symbol Set IDs and Symbol Set names (displays on both lines of the operator panel)</p> <p>10U PC-8* (Country specific) 12U PC-850* (Country specific)</p> <hr/> <p>A symbol set is a set of alphabetic and numeric characters, punctuation, and special symbols used when printing with a selected font. Symbol sets support the different requirements for languages or specific applications, such as math symbols for scientific text. The printer displays only the symbol sets supported for the selected font name.</p>
Orientation	<p>Portrait* Landscape</p> <hr/> <p>The Orientation setting determines how the printing is oriented on the page. Select Portrait to print parallel to the short edge of the print material.</p> <div data-bbox="665 951 796 1117" style="border: 1px solid black; padding: 5px; margin: 10px auto; width: fit-content;"> <p>This is PORTRAIT orientation. This is PORTRAIT orientation. This is</p> </div> <p>Select Landscape to print parallel to the long edge of the print material.</p> <div data-bbox="644 1216 812 1347" style="border: 1px solid black; padding: 5px; margin: 10px auto; width: fit-content;"> <p>This is LANDSCAPE orientation. This is LANDSCAPE orientation.</p> </div>
*Factory default	

PCL Emul Menu (continued)

Menu Item	Values
Lines per Page	<p>1...255 60* (Country specific) 64* (Country specific)</p> <hr/> <p>Use the Lines per Page menu item to change the number of lines that print on each page. The Lines per Page setting can range from 1 to 255 lines per page. The printer sets the amount of space between each line (vertical line spacing) based on the Lines per Page, PAPER SIZE, and Orientation settings. Select the correct PAPER SIZE from the PAPER MENU and Orientation before setting Lines per Page. See PAPER SIZE on page 45 and Orientation on page 80 for more information.</p>
A4 Width	<p>198 mm* 203 mm</p> <hr/> <p>The A4 Width menu item lets you select the width of the logical page for A4 paper. When you select 198 mm, the width of the logical page is compatible with that of the Hewlett-Packard LaserJet 5 printer. When you select 203 mm, the width of the logical page is wide enough to print eighty 10-pitch characters.</p>
*Factory default	

PCL Emul Menu (continued)

Menu Item	Values
TRAY RENUMBER	<p>Assign MP Feeder Assign Tray 1 Assign Tray 2 Assign Man Paper Assign Man Env</p> <p>Each of the above menu items supports the following three values:</p> <ul style="list-style-type: none"> Off* 0 ... 199 None <p>VIEW FACTORY DEF Restore Defaults</p> <ul style="list-style-type: none"> Yes No <p>Note: Assign Tray 2 only displays if the optional 500-sheet drawer is installed. Assign MP Feeder only displays when Configure MP is set to Cassette.</p> <hr/> <p>Only installed paper sources display on the operator panel as values. However, you may set TRAY RENUMBER to uninstalled sources.</p> <p>The TRAY RENUMBER menu item lets you configure your printer to work with printer drivers or applications that use different source assignments to request a given input source.</p> <p>Select Off to use the factory default paper source assignments.</p> <p>Select a numeric value (0 ... 199) to assign a custom value to a paper source.</p> <p>Select VIEW FACTORY DEF to view the factory default values assigned to each paper source.</p> <p>In the Restore Defaults menu item, select Yes to return all tray assignments to factory default values.</p> <p>See "Paper Sources and Sizes" on page 116 for information on available paper sources for your printer.</p> <p>Refer to the <i>Technical Reference</i> for more information about assigning source numbers.</p>
Auto CR after LF	<p>Off* On</p> <hr/> <p>The Auto CR after LF setting determines if the printer automatically performs a carriage return after a line feed control command.</p>
Auto LF after CR	<p>Off* On</p> <hr/> <p>The Auto LF after CR setting determines if the printer automatically performs a line feed after a carriage return control command.</p>
*Factory default	

PostScript Menu

Use the POSTSCRIPT MENU to change settings that only affect jobs printed using the PostScript 3 emulation printer language.

PostScript Menu

Menu Item	Values
Print PS Error	Off* On <hr/> Select On to print PostScript 3 emulation errors. If an error occurs, the job stops processing, the error message prints, and the printer discards the job. If Print PS Error is set to Off and an error occurs, the job is discarded but no error message prints.
Font Priority	Resident* Flash / Disk <hr/> The Font Priority menu item only displays if a flash memory or disk option is installed, formatted and is <i>not</i> defective, Read/Write or Write protected and Job Buffer Size is <i>not</i> set to 100% . See Job Buffer Size on page 77 for more information.
*Factory default	

Parallel Menu

Use the PARALLEL MENU to change settings affecting jobs sent to the printer through the parallel interface connection. PARALLEL MENU displays as a standard feature or as an option, and appears as one of the following:

- STD PARALLEL
- PARALLEL OPT 1

PARALLEL OPT 1 is only available if a parallel/USB interface option card is installed. The following menu items set the configuration of the parallel interface connection.

Parallel Menu

Menu Item	Values
PCL SmartSwitch	Off On* <hr/> <p>If PCL SmartSwitch is set to On, the printer examines the data on the parallel interface connection and selects PCL emulation if the data indicates that is the printer language.</p> <p>If both PCL SmartSwitch and PS SmartSwitch are set to Off, the printer uses the language specified in the Printer Language menu as the default. If only one SmartSwitch setting is set to Off, the printer uses the language that has its SmartSwitch setting set to On as the default.</p>
PS SmartSwitch	Off On* <hr/> <p>If PS SmartSwitch is set to On, the printer examines the data on the parallel interface connection and selects PostScript 3 emulation if the data indicates that is the printer language.</p> <p>If both PCL SmartSwitch and PS SmartSwitch are set to Off, the printer uses the language specified in the Printer Language menu as the default. If only one SmartSwitch setting is set to Off, the printer uses the language that has its SmartSwitch setting set to On as the default.</p>
*Factory default	

Parallel Menu (continued)

Menu Item	Values
NPA Mode	<p>On Off Auto*</p> <hr/> <p>NPA is a mode of bidirectional communication that follows the conventions defined in <i>Network Printing Alliance Protocol, A Printer/Host Control Specification Developed by the NPA</i>. NPA mode requires special processing of the print data.</p> <p>If NPA Mode is set to On, the data received must be in NPA format. If not, it is rejected as bad data. If NPA Mode is set to Off, the printer does not perform any NPA processing. If NPA Mode is set to Auto, the printer examines the data to determine the format and then processes it in either format.</p> <p>The NPA Mode setting in the PARALLEL MENU applies only to the parallel interface connection.</p> <p>Note: Changing the NPA Mode setting automatically resets the printer.</p>
Parallel Buffer	<p>Disabled Auto* 3K to maximum size allowed</p> <hr/> <p>You can configure the size of the parallel input buffer to meet the requirements of your system. The maximum size available for modification depends on the amount of memory in your printer, the size of the other link buffers, and whether Resource Save is set to On or Off. To maximize the range for the parallel buffer size, you can disable or reduce the size of the serial, network, infrared, LocalTalk, and Universal Serial Bus (USB) buffers.</p> <p>Choose Auto to let the printer calculate a buffer size proportional to the total amount of available printer memory. In most cases, Auto is the recommended setting.</p> <p>Note: Changing the Parallel Buffer setting automatically resets the printer.</p>
Job Buffering	<p>Off* On</p> <hr/> <p>Job buffering lets you delay processing of a print job. The job is temporarily stored on a hard disk option before being printed, usually freeing the host computer while the job prints.</p> <p>The Job Buffering menu item only displays if the installed hard disk option is formatted and is <i>not</i> defective, Read/Write or Write protected, and if Job Buffer Size is <i>not</i> set to Disabled. See Job Buffer Size on page 77 for more information. 61 Defective Disk may display when the printer is turned on, or during disk format and write operations. See 61 Defective Disk on page 165 for more information.</p> <p>If Job Buffering is set to On, print jobs are buffered to the hard disk option. If Job Buffering is set to Off, print jobs are not buffered.</p> <p>Note: Changing the Job Buffering setting automatically resets the printer.</p>
*Factory default	

Parallel Menu (continued)

Menu Item	Values
Advanced Status	Off On* <hr/> If Advanced Status is set to On , bidirectional communication is enabled through the parallel interface.
Protocol	Standard Fastbytes* <hr/> You can select Standard or Fastbytes protocol for the parallel interface. Fastbytes is compatible with most existing parallel interface implementations. Use Standard only if you experience parallel interface problems. Refer to the <i>Technical Reference</i> for more information about the parallel interface.
Honor Init	Off* On <hr/> The Honor Init setting determines whether the printer honors hardware initialization requests from the computer. The computer requests initialization by activating the INIT signal on the parallel interface. Many personal computers activate the INIT signal each time the computer is turned on and off.
Parallel Mode 1	Off On* <hr/> The Parallel Mode 1 setting controls the pull up resistors on the parallel port signals. It is useful for personal computers that have open collector outputs on the parallel port signals. Set Parallel Mode 1 to On to disable the resistors or to Off to enable the resistors. Note: This menu item is not available on the Opra M412.
Parallel Mode 2	Off On* <hr/> The Parallel Mode 2 setting determines if the parallel port data is sampled on the leading or trailing edge of strobe. If Parallel Mode 2 is set to On , the parallel port data is sampled on the leading edge of strobe. If Parallel Mode 2 is set to Off , the parallel port data is sampled on the trailing edge of strobe.
*Factory default	

Serial Menu

Use the SERIAL MENU to change settings affecting jobs sent to the printer through the serial interface port.

SERIAL MENU displays as an option, and appears as SERIAL OPTION 1. SERIAL OPTION 1 is only available if the Tri-Port interface option card is installed and **Fax Port** is set to disabled.

Serial Menu

Menu Item	Values
PCL SmartSwitch	Off On* <hr/> <p>If PCL SmartSwitch is set to On, the printer examines the data on the serial interface connection and selects PCL emulation if the data indicates that is the printer language.</p> <p>If both PCL SmartSwitch and PS SmartSwitch are set to Off, the printer uses the language specified in the Printer Language menu as the default. If only one SmartSwitch setting is set to Off, the printer uses the language that has its SmartSwitch setting set to On as the default.</p>
PS SmartSwitch	Off On* <hr/> <p>If PS SmartSwitch is set to On, the printer examines the data on the serial interface connection and selects PostScript 3 emulation if the data indicates that is the printer language.</p> <p>If both PCL Smartswitch and PS Smartswitch are set to Off, the printer uses the language specified in the Printer Language menu as the default. If only one SmartSwitch setting is set to Off, the printer uses the language that has its SmartSwitch setting set to On as the default.</p>
NPA Mode	On Off Auto* <hr/> <p>NPA is a mode of bidirectional communication that follows the conventions defined in <i>Network Printing Alliance Protocol, A Printer/Host Control Specification Developed by the NPA</i>. NPA mode requires special processing of the print data.</p> <p>If NPA Mode is set to On, the data received must be in NPA format. If not, it is rejected as bad data. If NPA Mode is set to Off, the printer does not perform any NPA processing. If NPA Mode is set to Auto, the printer examines the data to determine the format and then processes it in either format.</p> <p>The NPA Mode setting in the SERIAL MENU applies only to the serial interface connection.</p> <p>Note: Changing the NPA Mode setting automatically resets the printer.</p>
*Factory default	

Serial Menu (continued)

Menu Item	Values
Serial Buffer	<p>Disabled Auto* 3K to maximum size allowed</p> <hr/> <p>You can configure the size of the serial input buffer to meet the requirements of your system. If the limited size of the serial buffer is preventing you from continuing work in your software application each time you send a job to the printer, you may want to increase the buffer size.</p> <p>The maximum size depends on the amount of memory in your printer, the size of the other link buffers and whether the Resource Save setting is set to On or Off. To maximize the range for the serial buffer size, you can disable or reduce the size of the parallel, infrared, LocalTalk, and USB buffers. Choose Auto to let the printer calculate a buffer size proportional to the total amount of available printer memory. In most cases, Auto is the recommended setting.</p> <p>Note: Changing the Serial Buffer setting automatically resets the printer.</p>
RS-232/RS-422	<p>RS-232* RS-422</p> <hr/> <p>Choose the serial communication configuration for your printer. Selecting RS-422 automatically sets Serial Protocol to XON/XOFF.</p>
RS-422 Polarity	<p>Normal* Reverse</p> <hr/> <p>Select Normal or Reverse polarity.</p> <p>This setting is only available if the serial communication configuration is set to RS-422. To do this, select SERIAL MENU, SERIAL OPTION 1, RS-232/RS-422, and RS-422.</p>
Serial Protocol	<p>DTR* (hardware handshaking) DTR/DSR (hardware handshaking) XON/XOFF (software handshaking) XON/XOFF/DTR (combined handshaking) XON/XOFF/DTR/DSR (combined handshaking)</p> <hr/> <p><i>Handshaking</i> is the exchange of predetermined signals when a connection is established. This printer supports hardware handshaking, software handshaking, and combined hardware and software handshaking.</p> <p>Refer to the <i>Technical Reference</i> for more information about serial interface.</p>
Robust XON	<p>Off* On</p> <hr/> <p>Robust XON only applies to the serial port if Serial Protocol is set to XON/XOFF.</p> <p>When Robust XON is set to On, the printer sends a continuous stream of XONs to the host computer to indicate that the serial port is ready to receive more data.</p>
*Factory default	

Serial Menu (continued)

Menu Item	Values
Baud	1200 2400 4800 9600* 19200 38400 57600 115200 <hr/> This setting lets you select the rate at which data is being sent to or from your computer. Refer to the <i>Technical Reference</i> for information about the range of baud values.
Data Bits	7 8* <hr/> This setting lets you select the number of data bits that are sent in each transmission frame. Refer to the <i>Technical Reference</i> for more information about data bits.
*Factory default	

Serial Menu (continued)

Menu Item	Values
Parity	<p data-bbox="339 244 412 352">Even Odd None* Ignore</p> <hr data-bbox="339 378 629 383"/> <p data-bbox="339 388 1140 418">This setting lets you select the parity for serial input and output data frames.</p> <p data-bbox="376 427 1319 539">Even The port expects to receive data frames with an even number of logical 1's per byte. The port transmits XOFF and XON with even parity. If the port detects a parity error, the port sends an inverted question mark to the printer instead of the character sent by the host system.</p> <p data-bbox="376 545 1319 657">Odd The port expects to receive data frames with an odd number of logical 1's per byte. The printer transmits XOFF and XON with odd parity. If the printer detects a parity error, the port sends X'5F' to the printer instead of the character sent by the host system.</p> <p data-bbox="376 663 1319 716">None The port expects no parity bit when it receives data. The port transmits XON and XOFF without parity bits.</p> <p data-bbox="376 722 1319 775">Ignore The port expects a parity bit when the port receives a data frame. The port ignores the parity bit. The port uses even parity when it transmits XON and XOFF.</p> <p data-bbox="339 788 1043 817">Refer to the <i>Technical Reference</i> for more information about parity.</p>
Honor DSR (only available if configured for RS-232)	<p data-bbox="339 835 384 888">Off* On</p> <hr data-bbox="339 914 629 920"/> <p data-bbox="339 925 1319 1038">Honor DSR determines if the printer uses the Data Set Ready (DSR) signal. DSR is one of the handshaking signals for most serial interface cables. If Honor DSR is set to Off, data received by the serial interface is seen as valid data. If Honor DSR is set to On, only data received while the DSR signal is in high condition is treated as valid data.</p> <p data-bbox="339 1043 1319 1097">The serial interface uses DSR to distinguish data sent by the computer from data created by electrical noise in the serial cable. This electrical noise can cause stray characters to print.</p> <p data-bbox="339 1102 1001 1131">Set Honor DSR to On to prevent stray characters from printing.</p>
*Factory default	

Network Menu

Use the NETWORK MENU to change settings affecting jobs sent to the printer through the network port.

NETWORK MENU displays as an option, and appears as NETWORK OPTION 1. NETWORK OPTION 1 is only available if an optional print server is installed in your printer.

Network Menu

Menu Item	Values
PCL SmartSwitch	<p>Off On*</p> <hr/> <p>If PCL SmartSwitch is set to On, the printer examines the data on the network interface connection and selects PCL emulation if the data indicates that is the printer language.</p> <p>If both PCL SmartSwitch and PS SmartSwitch are set to Off, the printer uses the language specified in the Printer Language menu as the default. If only one SmartSwitch setting is set to Off, the printer uses the language that has its SmartSwitch set to On as the default.</p>
PS SmartSwitch	<p>Off On*</p> <hr/> <p>If PS SmartSwitch is set to On the printer examines the data on the network interface connection and selects PostScript 3 emulation if the data indicates that is the printer language.</p> <p>If both PCL SmartSwitch and PS SmartSwitch are set to Off, the printer uses the language specified in the Printer Language menu as the default. If only one SmartSwitch setting is set to Off, the printer uses the language that has its SmartSwitch setting set to On as the default.</p>
NPA Mode	<p>Off Auto*</p> <hr/> <p>NPA is a mode of bidirectional communication that follows the conventions defined in <i>Network Printing Alliance Protocol, A Printer/Host Control Specification Developed by the NPA</i>. NPA mode requires special processing of the print data.</p> <p>If NPA Mode is set to On, the data received must be in NPA format. If not, it is rejected as bad data. If NPA Mode is set to Off, the printer does not perform any NPA processing. If NPA Mode is set to Auto, the printer examines the data to determine the format and then processes it in either format.</p> <p>The NPA Mode setting in the NETWORK MENU applies only to the network interface connection.</p> <p>Note: Changing the NPA Mode setting automatically resets the printer.</p>
*Factory default	

Network Menu (continued)

Menu Item	Values
Network Buffer	<p>Auto* 3K to maximum size allowed</p> <hr/> <p>You can configure the size of the network input buffer to meet the requirements of your system. If the limited size of the network buffer is preventing you from continuing work in your software application each time you send a job to the printer, you may want to increase the buffer size.</p> <p>The maximum size available for modification depends on the amount of memory in your printer, the size of the other link buffers, and whether Resource Save is set to On or Off. To maximize the range for the network buffer size, you can disable or reduce the size of the parallel and USB buffers.</p> <p>Choose Auto to let the printer calculate the buffer size proportional to the total amount of available printer memory. In most cases, Auto is the recommended setting.</p> <p>Note: Changing the Network Buffer setting automatically resets the printer.</p>
Network 1 Setup	<p>Values for this menu item are supplied by the specific network card. Open the menu to see the available values.</p> <p>For more information, refer to the documentation that comes with your network option.</p>
*Factory default	

Infrared Menu

Use the INFRARED MENU to change settings affecting jobs sent to the printer through the infrared interface port.

If **Infrared Port** is set to **Disabled**, all other menu items in the INFRARED MENU are not available.

This menu is only available if the Tri-Port interface option card is installed in your printer.

Infrared Menu

Menu Item	Values
Infrared Port	Disabled* IR Option 1 <hr/> Select IR Option 1 to activate the infrared port on the Tri-Port interface option card. If you select Disabled , all of the other menu items in the INFRARED MENU are not available.
PCL SmartSwitch	Off On* <hr/> If PCL SmartSwitch is set to On , the printer examines the data on the infrared interface connection and selects PCL emulation if the data indicates that is the printer language. If both PCL SmartSwitch and PS SmartSwitch are set to Off , the printer uses the language specified in the Printer Language menu as the default. If only one SmartSwitch setting is set to Off , the printer uses the language that has its SmartSwitch setting set to On as the default.
PS SmartSwitch	Off On* <hr/> If PS SmartSwitch is set to On the printer examines the data on the network infrared connection and selects PostScript 3 emulation if the data indicates that is the printer language. If both PCL SmartSwitch and PS SmartSwitch are set to Off , the printer uses the language specified in the Printer Language menu as the default. If only one SmartSwitch setting is set to Off , the printer uses the language that has its SmartSwitch setting set to On as the default.
*Factory default	

Infrared Menu (continued)

Menu Item	Values
NPA Mode	<p>Off Auto*</p> <hr/> <p>NPA is a mode of bidirectional communication that follows the conventions defined in <i>Network Printing Alliance Protocol, A Printer/Host Control Specification Developed by the NPA</i>. NPA mode requires special processing of the print data.</p> <p>If NPA Mode is set to On, the data received must be in NPA format. If not, it is rejected as bad data. If NPA Mode is set to Off, the printer does not perform any NPA processing. If NPA Mode is set to Auto, the printer examines the data to determine the format and then processes it in either format.</p> <p>The NPA Mode setting in the INFRARED MENU applies only to the infrared interface connection.</p> <p>Note: Changing the NPA Mode setting automatically resets the printer.</p>
Infrared Buffer	<p>Disabled Auto* 5K to maximum size allowed</p> <hr/> <p>You can configure the size of the infrared input buffer to meet the requirements of your system. If the limited size of the input buffer is preventing you from continuing work in your software application each time you send a job to the printer, you may want to increase the buffer size.</p> <p>The maximum size available for modification depends on the amount of memory in your printer, the size of the other link buffers, and whether Resource Save is set to On or Off. To maximize the range for the infrared buffer size, you can disable or reduce the size of the parallel, serial, LocalTalk, and USB buffers.</p> <p>Choose Auto to let the printer calculate a buffer size proportional to the total amount of available printer memory. In most cases, Auto is the recommended setting.</p> <p>Note: Changing the Infrared Buffer setting automatically resets the printer.</p>
Window Size	<p>Auto* 1</p> <hr/> <p>The Window Size setting specifies the maximum number of infrared frames the printer can receive before it must send an acknowledgment to the host computer.</p> <p>Select Auto to let the printer automatically set the window size during a power on reset to maximize link performance.</p> <p>In most cases, Auto is the recommended setting. If you have trouble printing using the infrared port, changing the Window Size setting to 1 may resolve the problem.</p>
*Factory default	

Infrared Menu (continued)

Menu Item	Values
Transmit Delay	Auto* None 1...15 <hr/> The Transmit Delay setting defines the amount of time the printer must wait before transmitting meaningful infrared data to the host computer, as well as the amount of time the printer requests the host computer to wait before it transmits infrared data. Select Auto to let the printer automatically set the Transmit Delay value during a power on reset to maximize link performance. In most cases, Auto is the recommended setting. If you have trouble printing using the infrared port, selecting a high Transmit Delay setting, such as 15 , may resolve the problem.
Max Baud Rate	2400 9600 19200 38400 57600 115200 576000 1152000* 4000000 <hr/> The maximum baud rate possible for both the printer and the infrared adapter is automatically set during a power on reset. However, if your printer is situated in a bright or highly reflective environment, you may experience intermittent communication problems. If you do, select a lower baud rate for the infrared connection.
*Factory default	

LocalTalk Menu

Use the LOCALTALK MENU to change settings affecting jobs sent to the printer through the LocalTalk port.

If **LocalTalk Port** is set to **Disabled**, all other menu items in the LOCALTALK MENU are not available.

This menu is only available if the Tri-Port interface option card is installed in your printer.

LocalTalk Menu

Menu Item	Values
LocalTalk Port	Disabled* LTalk Option 1 <hr/> Select LTalk Option 1 to activate the LocalTalk port on the Tri-Port interface option card. If you select Disabled , all of the other menu items in the LOCALTALK MENU are not available.
PCL SmartSwitch	Off On* <hr/> If PCL SmartSwitch is set to On , the printer examines the data on the LocalTalk interface connection and selects PCL emulation if the data indicates that is the printer language. If both PCL SmartSwitch and PS SmartSwitch are set to Off , the printer uses the language specified in the Printer Language menu as the default. If only one SmartSwitch setting is set to Off , the printer uses the language that has its SmartSwitch setting set to On as the default.
PS SmartSwitch	Off On* <hr/> If PS SmartSwitch is set to On , the printer examines the data on the specified LocalTalk interface connection and selects PostScript 3 emulation if the data indicates that is the printer language. If both PCL SmartSwitch and PS SmartSwitch are set to Off , the printer uses the language specified in the Printer Language menu as the default. If only one SmartSwitch setting is set to Off , the printer uses the language that has its SmartSwitch setting set to On as the default.
*Factory default	

LocalTalk Menu (continued)

Menu Item	Values
NPA Mode	<p>Off Auto*</p> <hr/> <p>NPA is a mode of bidirectional communication that follows the conventions defined in <i>Network Printing Alliance Protocol, A Printer/Host Control Specification Developed by the NPA</i>. NPA mode requires special processing of the print data.</p> <p>If NPA Mode is set to On, the data received must be in NPA format. If not, it is rejected as bad data. If NPA Mode is set to Off, the printer does not perform any NPA processing. If NPA Mode is set to Auto, the printer examines the data to determine the format and then processes it in either format.</p> <p>The NPA Mode setting in the LOCALTALK MENU applies only to the LocalTalk interface connection.</p> <p>Note: Changing the NPA Mode setting automatically resets the printer.</p>
LocalTalk Buffer	<p>Disabled Auto* 6K to maximum size allowed</p> <hr/> <p>You can configure the size of the LocalTalk input buffer to meet the requirements of your system. If the limited size of the input buffer is preventing you from continuing work in your software application each time you send a job to the printer, you may want to increase the buffer size.</p> <p>The maximum size available for modification depends on the amount of memory in your printer, the size of the other link buffers, and whether Resource Save is set to On or Off. To maximize the range for the LocalTalk buffer size, you can disable or reduce the size of the parallel, serial, infrared, and USB buffers.</p> <p>Choose Auto to let the printer calculate a buffer size proportional to the total amount of available printer memory. In most cases, Auto is the recommended setting.</p> <p>Note: Changing the LocalTalk Buffer setting automatically resets the printer.</p>
NPA Hosts	<p>1...10 (2*)</p> <hr/> <p>Use this setting to specify the maximum number of NPA hosts that can register for NPA printer alerts. When the number of hosts registered for NPA alerts exceeds the quantity specified by NPA Hosts, any additional hosts attempting to register for alerts are ignored.</p> <p>Note: Changing the NPA Hosts setting automatically resets the printer.</p>
LocalTalk Name	<p>Lexmark Optra M410 or Lexmark Optra M412</p> <hr/> <p>This setting identifies the printer model name stored in printer memory. It cannot be modified through the operator panel.</p>
*Factory default	

LocalTalk Menu (continued)

Menu Item	Values
LocalTalk Addr	(LocalTalk Node Number) _____ This setting identifies the LocalTalk Node number assigned to the printer. It cannot be modified through the operator panel.
LocalTalk Zone	(Zone name provided by LocalTalk network) _____ This setting determines the LocalTalk Zone. It cannot be modified through the operator panel.
*Factory default	

USB Menu

Use the USB MENU to change settings affecting the Universal Serial Bus (USB) interface port. The USB MENU displays as a standard feature or as an option, and appears as one of the following:

- STANDARD USB
- USB OPTION 1

USB OPTION 1 is only available if a parallel/USB interface option card is installed on the printer system board. See “Using a USB Cable” on page 14 for information on how to attached a USB cable and “Parallel/USB Interface Option Card” on page 215 for installation information.

USB Menu

Menu Item	Values
PCL SmartSwitch	Off On* <hr/> <p>If PCL SmartSwitch is set to On, the printer examines the data on the USB interface connection and selects PCL emulation if the data indicates that is the printer language.</p> <p>If both PCL SmartSwitch and PS SmartSwitch are set to Off, the printer uses the language specified in the Printer Language menu as the default. If only one SmartSwitch setting is set to Off, the printer uses the language that has its SmartSwitch setting set to On as the default.</p>
PS SmartSwitch	Off On* <hr/> <p>If PS SmartSwitch is set to On, the printer examines the data on the specified USB interface connection and selects PostScript 3 emulation if the data indicates that is the printer language.</p> <p>If both PCL SmartSwitch and PS SmartSwitch are set to Off, the printer uses the language specified in the Printer Language menu as the default. If only one SmartSwitch setting is set to Off, the printer uses the language that has its SmartSwitch setting set to On as the default.</p>
*Factory default	

USB Menu (continued)

Menu Item	Values
NPA Mode	<p>On Off Auto*</p> <hr/> <p>NPA is a mode of bidirectional communication that follows the conventions defined in <i>Network Printing Alliance Protocol, A Printer/Host Control Specification Developed by the NPA</i>. NPA mode requires special processing of the print data.</p> <p>If NPA Mode is set to On, the data received must be in NPA format. If not, it is rejected as bad data. If NPA Mode is set to Off, the printer does not perform any NPA processing. If NPA Mode is set to Auto, the printer examines the data to determine the format and then processes it in either format.</p> <p>The NPA Mode setting in the USB MENU applies only to the USB interface connection.</p> <p>Note: Changing the NPA Mode setting automatically resets the printer.</p>
USB Buffer	<p>Disabled Auto* 3K to maximum size allowed</p> <hr/> <p>You can configure the size of the USB input buffer to meet the requirements of your system. If the limited size of the input buffer is preventing you from continuing work in your software application each time you send a job to the printer, you may want to increase the buffer size.</p> <p>The maximum size available for modification depends on the amount of memory in your printer, the size of the other link buffers, and whether Resource Save is set to On or Off. To maximize the range for the USB buffer size, you can disable or reduce the size of the parallel, serial, network, infrared, and LocalTalk buffers.</p> <p>Choose Auto to let the printer calculate a buffer size proportional to the total amount of available printer memory. In most cases, Auto is the recommended setting.</p> <p>Note: Changing the USB Buffer setting automatically resets the printer.</p>
*Factory default	

USB Menu (continued)

Menu Item	Values
Job Buffering	<p data-bbox="372 244 415 296">Off* On</p> <hr data-bbox="372 322 662 326"/> <p data-bbox="372 336 1300 388">This menu item only displays if you are using standard USB and have a hard disk option card installed.</p> <p data-bbox="372 401 1290 479">Job buffering lets you delay processing of a print job. The job is temporarily stored on a hard disk option before being printed, usually freeing the host computer while the job prints.</p> <p data-bbox="372 491 1319 626">The Job Buffering menu item only displays if the installed hard disk option is formatted and is <i>not</i> defective, Read/Write or Write protected, and if Job Buffer Size is <i>not</i> set to Disabled. See Job Buffer Size on page 77 for more information. 61 Defective Disk may display when the printer is turned on, or during disk format and write operations. See 61 Defective Disk on page 165 for more information.</p> <p data-bbox="372 638 1319 690">If Job Buffering is set to On, print jobs are buffered to the hard disk option. If Job Buffering is set to Off, print jobs are not buffered.</p> <p data-bbox="372 703 1148 725">Note: Changing the Job Buffering setting automatically resets the printer.</p>
*Factory default	

Fax Menu

Use the FAX MENU to change settings affecting fax data received by the printer through the serial interface port on the Tri-Port interface option card.

With the Tri-Port interface option card installed, the printer can receive and print fax data.

If **Fax Port** is set to **Disabled**, all other menu items in the FAX MENU are not available.

Ser Option 1 is only available if a Tri-Port interface option card is installed in your printer. See “Tri-Port Interface Option Card” on page 212 or “Fax” on page 197 for more information.

Fax Menu

Menu Item	Values
Fax Port	Disabled* Ser Option 1 <hr/> Select Ser Option 1 to activate the serial port on the Tri-Port interface option card and configure it to receive fax data. If you select Disabled , all of the other menu items in the FAX MENU are not available.
Fax Baud	1200 2400 4800 9600 19200* 38400 57600 115200 <hr/> This setting lets you select the rate at which fax data is being sent to or from your computer. Refer to the <i>Technical Reference</i> for information about the range of baud values.
Fax Data Bits	7 8* <hr/> This setting lets you select the number of fax data bits that are sent in each transmission frame. Refer to the <i>Technical Reference</i> for more information about data bits.
*Factory default	

Fax Menu (continued)

Menu Item	Values
Fax Parity	<p>Even Odd None* Ignore</p> <hr/> <p>The Fax Parity setting lets you select the parity for fax data frames.</p> <p>Even The port expects to receive data frames with an even number of logical 1's per byte. The port transmits XOFF and XON with even parity. If the port detects a parity error, it sends an inverted question mark to the printer instead of the character sent by the host system.</p> <p>Odd The port expects to receive data frames with an odd number of logical 1's per byte. The printer transmits XOFF and XON with odd parity. If the printer detects a parity error, it sends X'5F' to the printer instead of the character sent by the host system.</p> <p>None The port expects no parity bit when it receives data. The port transmits XON and XOFF without parity bits.</p> <p>Ignore The port expects a parity bit when it receives a data frame. The port ignores the parity bit and uses even parity when it transmits XON and XOFF.</p> <p>Refer to the <i>Technical Reference</i> for more information about parity.</p>
Fax Buffer	<p>Disabled Auto* 105K to max size allowed</p> <hr/> <p>You can configure the size of the fax input buffer to meet the requirements of your system. If the limited size of the input buffer is preventing you from receiving fax data, you may want to increase the fax buffer size.</p> <p>The maximum size depends on the amount of memory in your printer, the size of the other link buffers and whether the Resource Save setting is set to On or Off. To maximize the range for the fax buffer size, you can disable or reduce the size of the parallel, infrared, LocalTalk, and USB buffers.</p> <p>Choose Auto to let the printer calculate a buffer size proportional to the total amount of available printer memory. In most cases, Auto is the recommended setting.</p> <p>Note: Changing the Fax Buffer setting automatically resets the printer.</p>
*Factory default	

Fax Menu (continued)

Menu Item	Values
Fax Paper Size	<p>A4* (Country specific) A5 JIS B5 Letter* (Country specific) Legal Executive Universal</p> <hr/> <p>The Fax Paper Size setting lets you specify the size of print material used for printing fax data. Incoming faxes are automatically formatted to print on the paper size set in the Fax Paper Size menu item.</p> <p>The printer automatically prints from the paper source containing the correct paper size and paper type as specified in the Fax Paper Size and Fax Paper Type settings. If no paper source contains the correct paper size and paper type, you are prompted to change the print material in a selected source to match the Fax Paper Size and Fax Paper Type settings. See Fax Paper Type on page 105 for more information.</p>
*Factory default	

Fax Menu (continued)

Menu Item	Values
Fax Paper Type	<p data-bbox="329 244 492 621"> Plain Paper* Card Stock Transparency Labels Bond Letterhead Preprinted Colored Paper Custom Type 1 Custom Type 2 Custom Type 3 Custom Type 4 Custom Type 5 Custom Type 6 </p> <hr data-bbox="329 644 621 647"/> <p data-bbox="329 656 1333 829"> The Fax Paper Type setting lets you specify the type of print material used for printing fax data. The printer automatically prints from the paper source containing the correct paper size and paper type as specified in the Fax Paper Size and Fax Paper Type settings. If no paper source contains the correct paper size and paper type, you are prompted to change the print material in a selected source to match the Fax Paper Size and Fax Paper Type settings. See Fax Paper Size on page 104 for more information. </p> <p data-bbox="329 838 1333 920"> Custom Type 1 through 6 refers to special types of print materials. You can change the names through a utility, such as MarkVision. The user-defined name is truncated to 14 characters. For more information on setting the Custom Type names, see CUSTOM TYPES on page 49. </p>
*Factory default	

Config Menu

You only have access to the CONFIG MENU if you follow these steps:

- 1 Turn the printer power Off (O).**
- 2 Press and hold the Select and Return buttons and turn the printer power On (|).**
- 3 Release the buttons when Performing Self Test appears on the operator panel display.**

When the printer self test completes, the **CONFIG MENU** displays.

When you exit the CONFIG MENU, the printer restarts automatically and returns to the **Ready** state. See **Exit Config Menu** on page 107 for more information.

Config Menu

Menu Item	Values
Prt Quality Pgs	Press Select to print the quality test pages. The first page contains a combination of graphics and text which always prints in English. The second and third pages contain graphics only. Note: PAPER SIZE must be set to Letter, Legal, or A-4 to print quality test pages. See PAPER SIZE on page 45 for more information.
Panel Menus	Disable Enable* <hr/> For more information, see "Disabling the Operator Panel Menus" on page 41.
Buffered Jobs	Discard <hr/> Select Discard to delete all print jobs stored in the print buffer. The message Formatting Disk briefly appears while the buffered jobs are being discarded. See Formatting Disk on page 153 for more information.
*Factory default	

Config Menu (continued)

Menu Item	Values
Factory Defaults	<p>Restore All</p> <hr/> <p>If you select Restore All:</p> <ul style="list-style-type: none"> • All downloaded resources (fonts, macros, symbol sets) in printer memory (RAM) are deleted. (Resources residing in flash memory or on the hard disk option are unaffected.) • All menu settings are returned to the factory default values except: <ul style="list-style-type: none"> – Display Language (SETUP MENU) which is the operator panel display language. – All settings in the PARALLEL MENU, SERIAL MENU, NETWORK MENU, INFRARED MENU, LOCALTALK MENU, USB MENU, and FAX MENU. <p>The message Restoring Factory Defaults briefly appears while the printer restores the factory default settings. See Restoring Factory Defaults on page 157 for more information.</p>
NARROW MEDIA	<p>Plain Width Card Stock Width Trnsprncy Width Labels Width Bond Width Letterhead Width Preprinted Width Colored Width Envelope Width Custom 1 Width Custom 2 Width Custom 3 Width Custom 4 Width Custom 5 Width Custom 6 Width</p> <p>Each of the above menu items support the following values as a second menu:</p> <p style="padding-left: 20px;">Normal* Narrow</p> <hr/> <p>Set NARROW MEDIA to Narrow when using print material less than 172 mm (6.77 in.) in width, so the printer can adjust its speed, thus prolonging the life of the fuser.</p> <p>Custom x Width refers to special types of print materials. You can change the names through a utility, such as MarkVision. If a user-defined name is available, the name displays instead of Custom x Width, where x represents a number 1 through 6. The user-defined name is truncated to 16 characters.</p>
Exit Config Menu	<p>Press Select to exit the CONFIG MENU. The printer automatically restarts and returns to the Ready state.</p>
*Factory default	

Understanding Print and Hold Jobs

Note: The Print and Hold function requires a total of 8MB or more of memory. We recommend installing 16MB or more of memory and a hard disk option.

The Print and Hold function lets you delay the printing of a job, print it later, and ask for additional copies.

The types of Print and Hold jobs are:

- Confidential Job
- Repeat Print Job
- Reserve Print Job
- Verify Print Job

In the JOB MENU, there are two categories or menu items of Print and Hold jobs:

- CONFIDENTIAL JOB
- HELD JOBS

Repeat Print job, Reserve Print job, and Verify Print job are grouped into the category called Held Jobs.

You select the type of job you want from your software application or printer driver. To access your jobs once they are sent to print, you must use the operator panel or the remote operator panel in MarkVision to enter the **JOB MENU**.

Confidential Jobs

When you send a Confidential Job, the printer formats your job and holds the job in memory. The printer delays the printing of your job until you enter a PIN assigned to the job. You enter the number through the operator panel. See “Entering a Personal Identification Number (PIN)” on page 111 for more information.

For more information about Confidential Jobs, see **CONFIDENTIAL JOB** on page 60.

- To print all Confidential Jobs, see **Print All Jobs** on page 62.
- To print a specific Confidential Job, see **PRINT A JOB** on page 62.
- To print additional copies of a Confidential Job, see **PRINT COPIES** on page 64.

- To delete all Confidential Jobs, see **Delete All Jobs** on page 63.
- To delete a specific Confidential Job, see **DELETE A JOB** on page 63.

Held Jobs

Held Jobs refers any of the following types of jobs: Repeat Print job, Reserve Print job, and Verify Print job.

Repeat Print Job

When you create a Repeat Print job, the job formats and prints, but the printer stores the job in memory so you can print additional copies of the job at a later time. As long as the job remains stored in memory, you may print additional copies. Repeat Jobs are automatically deleted when the printer requires extra memory to process additional jobs or when the number of Repeat Jobs stored exceeds the value of the setting for **Print and Hold Repeat Job Limit**. For more information about this setting, refer to the *Technical Reference*.

Reserve Print Job

When you create a Reserve Print job, the job formats, but does not print. The printer stores the job in memory so you can print the job at a later time. All pages in the job are held in memory until you activate printing by using the operator panel to select **Print All Jobs** or **PRINT A JOB**. Reserve Print jobs are not deleted from memory when the job prints. To delete a Reserve Print job, you must request **DELETE A JOB** using the operator panel.

Verify Print Job

When you create a Verify Print job, the job formats, and one copy of the job prints. Additional requested copies are held in printer memory. You specify the number of copies you want when you send the job from the printer driver. This allows you to examine the first copy to see if it is satisfactory before you print the other copies.

If the job is unsatisfactory, you would not want the other copies to print. To delete the job, you must select the **DELETE A JOB** value, and select this job to delete it. See **DELETE A JOB** on page 68 for more information.

If the job is satisfactory, you can change the number of copies to print or print the number of copies already set in the printer driver.

To change the number of remaining copies to print:

- 1 Select PRINT COPIES.**
- 2 Select the specific job.**
- 3 At the Copies prompt, change the number of copies to print from the number set in the printer driver and press Select.**
- 4 Press Return until you exit the menus or press Go to exit the menus.** Once the printer exits the menus and returns to an online state, the remaining copies print.

Once all copies are printed, the job is deleted from printer memory. For more information, see **PRINT COPIES** on page 69.

To print the number of copies set in the printer driver:

- 1 Select PRINT A JOB.**
- 2 Select the specific job.** The remaining copies print.

Once all copies are printed, the job is deleted from printer memory. For more information, see **PRINT A JOB** on page 67.

Printing and Deleting Held Jobs

Once you have sent a Repeat Print job, a Reserve Print job, or a Verify Print job from the software application or the printer driver and have selected a value in the **HELD JOBS** menu item, the jobs are displayed on the operator panel in lists. You may choose to delete all, delete one or more individually, print all, print one or more individually, or print multiple copies of a job.

- To print all Held Jobs, see **Print All Jobs** on page 67.
- To print one or more Held Jobs by selecting them individually, see **PRINT A JOB** on page 67.
- To print additional copies of a Held Job, see **PRINT COPIES** on page 69.
- To delete all Held Jobs, see **Delete All Jobs** on page 68.
- To delete one or more Held Jobs by selecting them individually, see **DELETE A JOB** on page 68.

Entering a Personal Identification Number (PIN)

Once you send a Confidential Job from your software application or printer driver, it is processed and held in printer memory. A Personal Identification Number (PIN) is paired with the print job in printer memory.

Entry of the PIN using the operator panel is required to delete or print a Confidential Job.

When you want to access your Confidential Job held in printer memory, you:

- 1 Press Menu> to enter the menus and go to the JOB MENU.**

If **JOB MENU** is on the first line of the display, continue with step 2. If **JOB MENU** is on the second line, press **Select**.
- 2 Continue to press and release Menu> until you see CONFIDENTIAL JOB on the second line of the display.**

3 Press Select.

The following prompt appears on the display:

Enter PIN:

= _____

You are required to enter the four-digit PIN associated with your Confidential Job next to the equal sign (=). Each digit must be a number from 1 to 6.

At this point, the buttons on the operator panel cease to function as before, such as scrolling through the menus. You press the numbers on the operator panel like pressing numbers on a calculator. To simplify the operator panel, the illustration shows just the numbers and not the names of the operator panel buttons.

As you press each button to enter each digit of your PIN, an asterisk (*) appears on the display.

If you make a mistake entering your PIN, for instance, if you enter a number incorrectly, continue to press any of the buttons until the message **No Jobs Found. Retry?** displays. Press **Go** to refresh the operator panel and the **Enter PIN:** prompt displays again.

If you enter a PIN that does not match any Confidential Job in printer memory, the message **No Jobs Found. Retry?** displays. Press **Go** to refresh the operator panel and display the **Enter PIN:** prompt again or press **Stop** to cancel the entry of a PIN.

Note: If you enter the **Enter PIN** prompt in error or need to exit from this prompt, you must wait until the **No Jobs Found. Retry?** message displays and then press **Stop**.

Once you successfully enter the PIN, the printer checks the PIN with each stored PIN associated with each Confidential Job in printer memory. If the number matches, you are given access to the next level of the **CONFIDENTIAL JOB** menu item where you can select to print or delete jobs matching the PIN.

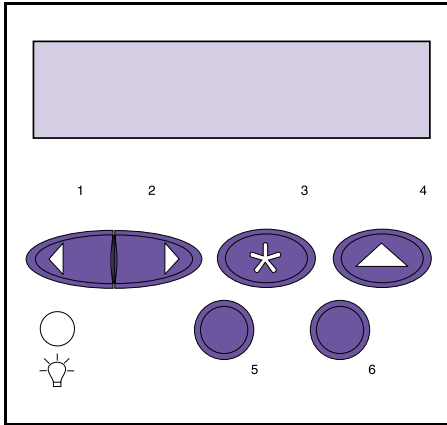

Print and Hold Formatting Errors

A lightning bolt symbol displays on the operator panel to indicate a formatting error occurred on at least one type of Print and Hold job. It looks like this:



Note: For documentation purposes, *Print and Hold jobs* refers to any of the following jobs: Confidential Job, Repeat Print Job, Reserve Print Job, and Verify Print Job.

When this type of error occurs, a portion of the processed job may still print, so the printer does not discard the entire job. Instead the lightning bolt displays to tell you that there is a formatting error on the particular job.

When any values are selected from either the **CONFIDENTIAL JOB** menu item or the **HELD JOBS** menu item, the symbol displays next to the value if at least one job experiences a formatting error as shown:

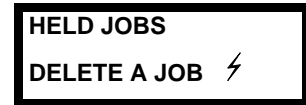
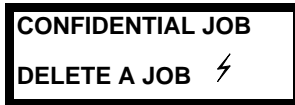
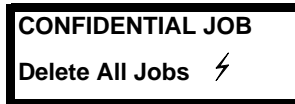
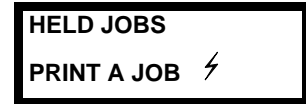
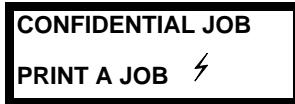

Once you select **PRINT A JOB**, **DELETE A JOB**, or **PRINT COPIES** values in the **CONFIDENTIAL JOB** menu item or the **HELD JOBS** menu item, the lightning bolt displays by the value if the currently displayed job experiences a formatting error. For example, if three jobs are sent to print and the second job experiences a formatting error, when you select **PRINT COPIES**, the operator panel displays as follows as you use the **Menu>** button to scroll to each job:

PRINT COPIES
Job #1

PRINT COPIES ⚡
Job #2

PRINT COPIES
Job #3

The lightning bolt only displays for the second job since it is the only job that encountered a formatting error.

4

Using Print Materials

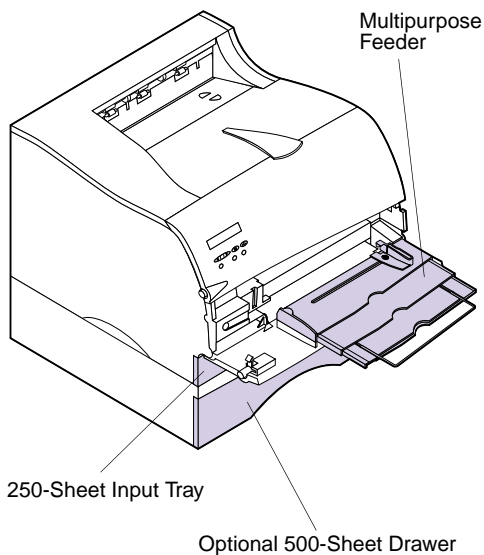

This chapter provides specifications and guidelines for each type of print material that can be used with your printer, as well as important information about the paper sources and the output bins.

Your printer has two standard paper sources, the 250-sheet input tray and the multipurpose feeder, and two output bins, providing high quality printing on a variety of print materials from different paper sources.

Load the print material you use for the majority of your print jobs in the 250-sheet input tray.

Reserve the multipurpose feeder for when you print on different sizes and types of print material, such as card stock, transparencies, postcards, note cards, and envelopes. You may also want to use the multipurpose feeder for single page print jobs on letterhead, or other special print material you do not keep in an input tray.

Note: You may purchase an optional 500-sheet drawer as a paper source. See “Optional 500-Sheet Drawer” on page 223 for installation information.

Paper Sources and Sizes

The following table details the types and quantities of media you can load in each of the paper sources. For more information about selecting specific print material for use with your printer, see “Print Material Guidelines” on page 118.

Note: For detailed information about print material characteristics, refer to the *Card Stock & Label Guide* on the CD that comes with your printer.

See “Paper and Envelope Dimensions” on page 117 for a list of the print material and envelope sizes your printer supports.

Paper Source Specifications

Source	Media	Sizes	Paper Weight ¹	Capacity ²
Tray 1 (250-sheet input tray)	Paper, labels, transparencies	A4, JIS B5, letter, legal, executive	60 to 90 g/m ² (16 to 24 lb)	250 sheets paper up to 100 labels ³ 50 transparencies
Tray 2 (optional 500-sheet drawer)	Paper only	A4, JIS B5, letter, legal, executive	60 to 90 g/m ² (16 to 24 lb)	500 sheets paper
Multipurpose feeder	Paper, envelopes, labels, transparencies, card stock ⁴	Minimum: 69.85 x 127 mm (2.75 x 5.0 in.) ⁵ Maximum: 215.9 x 356 mm (8.5 x 14 in.) Supports all sizes listed in the “Paper and Envelope Dimensions” table on page 117.	60 to 163 g/m ² (16 to 43 lb)	100 sheets paper 10 envelopes 30 labels 20 transparencies 10 sheets card stock

¹ This refers to paper only. For weights of other print materials, refer to the *Card Stock & Label Guide* for more information.

² For 20 lb print material, unless otherwise noted.

³ Refer to the *Card Stock & Label Guide* for more information.

⁴ 3 x 5 in. and 4 x 6 in. index cards must exit to the rear output bin.

⁵ Print material 152.4 mm (6 in.) or less in length must exit to the rear output bin.

The following table lists the paper and envelope sizes you can use with your printer.

Paper and Envelope Dimensions

Paper	Dimensions	Envelope	Dimensions
A4	210 x 297 mm (8.27 x 11.7 in.)	7 3/4 Envelope (Monarch)	98.4 x 190.5 mm (3.875 x 7.5 in.)
A5 (Multipurpose feeder only)	148 x 210 mm (5.83 x 8.27 in.)	9 Envelope	98.4 x 225.4 mm (3.875 x 8.875 in.)
JIS B5	182 x 257 mm (7.17 x 10.12 in.)	10 Envelope (Com-10)	104.8 x 241.3 mm (4.125 x 9.5 in.)
Letter	215.9 x 279.4 mm (8.5 x 11 in.)	DL Envelope	110 x 220 mm (4.33 x 8.66 in.)
Legal	215.9 x 356 mm (8.5 x 14 in.)	C5 Envelope	162 x 229 mm (6.38 x 9.01 in.)
Executive	184.2 x 266.7 mm (7.25 x 10.5 in.)	B5 Envelope	176 x 250 mm (6.93 x 9.84 in.)
Universal ¹ (Multipurpose feeder only)	215.9 x 356 mm (8.5 x 14 in.)	Other Envelope ²	229.11 x 356 mm (9.02 x 14 in.)
<p>¹ Select this value when using a non-standard size sheet of print material. The printer formats the page for the maximum size (8.5 x 14 in.). Set the actual size from your software application.</p> <p>² Select this value when using a non-standard size of envelope. The printer formats the envelope for the maximum size (9.02 x 14 in.). Set the actual size from your software application.</p>			

Print Material Guidelines

Note: For detailed information about print material characteristics, refer to the *Card Stock & Label Guide* on the CD that comes with your printer.

Selecting the appropriate print material (paper, transparencies, envelopes, labels, and card stock) for your printer helps you avoid printing problems.

The following sections contain guidelines for choosing the correct print material for your printer.

Paper

For the best print quality, use 75 g/m² (20 lb) xerographic, grain long paper. Try a sample of any paper you are considering using with the printer before buying large quantities.

When loading paper, note the recommended print side on the paper package, and load paper accordingly. See “Loading Print Material” on page 124 for detailed loading instructions.

The following papers are not recommended for use with your printer:

- Paper with a rough or heavily textured surface
- Coated papers, such as erasable bond
- Preprinted papers manufactured with chemicals that may contaminate the printer
- Multiple-part forms
- Synthetic papers
- Thermal papers
- Recycled paper having a weight less than 75 g/m² (20 lb)

Letterhead

Preprinted papers such as letterhead must be able to withstand temperatures up to 200°C (392°F) without melting or releasing hazardous emissions. Use inks that are not affected by the resin in toner or the silicone in the fuser. Inks that are oxidation-set or oil-based should meet these requirements; latex inks might not.

Transparencies

You can feed transparencies from the 250-sheet input tray or the multipurpose feeder. Try a sample of any transparencies you are considering using with the printer before buying large quantities.

Do not load transparencies in the optional 500-sheet drawer. To load transparencies in the 250-sheet input tray, see page 124. To load transparencies in the multipurpose feeder, see page 141.

Warning! When printing on transparencies, be sure to set the **PAPER TYPE to Transparency** from the printer driver, and from either the operator panel or from MarkVision to avoid damaging your printer.

When printing on transparencies:

- Use transparencies designed specifically for laser printers. Transparencies must be able to withstand temperatures of 175°C (347°F) without melting, discoloring or releasing hazardous emissions.
- To prevent print quality problems, avoid getting fingerprints on the transparencies.
- Before loading transparencies, fan the stack to prevent sheets from sticking together.

Envelopes

You can load up to 10 envelopes in the multipurpose feeder. Try a sample of any envelopes you are considering using with the printer before buying large quantities. See page 141 for loading instructions.

Note: When printing on envelopes, be sure to set the **PAPER SOURCE to MP Feeder or Manual Env**, set the **PAPER TYPE to Envelope**, and select the correct envelope size from the printer driver, and from either the operator panel or from MarkVision.

When printing on envelopes:

- Use envelopes made from 75 to 105 g/m² (20 to 28 lb) bond paper. For best performance and fewer paper jams, do *not* use envelopes that:
 - Have excessive curl.
 - Are stuck together.
 - Are damaged in any way.
 - Contain windows, holes, perforations, cutouts or embossing.
 - Use metal clasps, string ties, or metal folding bars.
 - Have postage stamps attached.
 - Have any exposed adhesive when the flap is in the sealed or closed position.

- Use envelopes that can withstand temperatures of 205°C (401°F) without sealing, excessive curling, wrinkling, or releasing hazardous emissions.
- Adjust the right paper guide to fit the width of the envelopes.
- Load envelopes with the flap side down and the short edge nearest the return address positioned to enter the printer first. See page 147 for an illustration for loading envelopes.
- If you are feeding self-sealing envelopes, open the rear output bin door so envelopes feed straight out the back of the printer. The rear output bin holds about 10 envelopes.

Labels

Your printer can print on many labels designed for use with laser printers. These labels are supplied in letter-size and A4-size sheets. Label adhesives, face sheet (printable stock), and topcoats must be able to withstand temperatures of 205°C (401°F) and pressure of 25 pounds per square inch (psi).

Try a sample of any labels you are considering using with the printer before purchasing a large quantity.

For detailed information on label printing, characteristics and design, refer to the *Card Stock & Label Guide* on the CD that comes with your printer.

Note: When printing on labels, be sure to set the **PAPER TYPE** to **Labels** from the printer driver, and from either the operator panel or from MarkVision.

When printing on labels:

- Do *not* load labels together with paper or transparencies in the same paper source.
- Do *not* use label sheets with a slick backing material.
- Do *not* print within 1 mm (0.040 in.) of the die cut.
- Use full label sheets. Partial sheets may cause labels to peel off during printing, resulting in a paper jam. Partial sheets will also contaminate your printer and your cartridge with adhesive, and could void your printer and cartridge warranties.

- Use labels that can withstand temperatures of 205°C (401°F) without sealing, excessive curling, wrinkling, or releasing hazardous emissions.
- Do *not* print within 1 mm (0.040 in.) of the edge of the label, of the perforations, or between die-cuts of the label.
- Do *not* use label sheets that have adhesive to the edge of the sheet. We recommend zone coating of the adhesive at least 1 mm (0.040 in.) away from edges. Adhesive material will contaminate your printer and could void your warranty.
- If zone coating of the adhesive is not possible, a 3 mm (0.125 in.) strip should be removed on the leading and driver edge, and a non-oozing adhesive should be used.
- Remove a 3 mm (0.125 in.) strip from the leading edge to prevent labels from peeling inside the printer.
- Portrait orientation is preferred, especially when printing bar codes.
- Do *not* use labels that have exposed adhesive.
- You may feed vinyl labels from the 250-sheet input tray and the multipurpose feeder.

After continuously printing approximately 10,000 pages of labels (or each time you replace the print cartridge), complete the following steps to maintain printer feeding reliability:

- 1 Print 5 sheets of paper.**
- 2 Wait approximately 5 seconds.**
- 3 Print 5 more sheets of paper.**

Card Stock Guidelines

Card stock is single ply, and has a large array of properties, such as the orientation of paper fibers and texture, that can significantly affect the print quality.

Try a sample of any card stock you are considering using with the printer before purchasing a large quantity.

See page 116 for information on the preferred weight of print materials.

Note: When printing on card stock, be sure to set the **PAPER TYPE** to **Card Stock** from the printer driver, and from either the operator panel or from MarkVision.

When printing on card stock:

- Use card stock that can withstand temperatures of 205°C (401°F) without sealing, excessive curling, wrinkling, or releasing hazardous emissions.
- Do *not* use preprinted card stock manufactured with chemicals that may contaminate the printer. Preprinting introduces semi-liquid and volatile components in the printer.
- Do *not* use card stock that is perforated or creased. It may cause paper jams.
- We recommend the use of grain short card stock.

After printing approximately 10,000 pages of card stock (or each time you replace the print cartridge), complete the following steps to maintain printer feeding reliability:

- 1 Print 5 sheets of paper.**
- 2 Wait approximately 5 seconds.**
- 3 Print 5 more sheets of paper.**

For detailed information on card stock printing, characteristics, and design, refer to the *Card Stock & Label Guide* on the CD.

Storing Print Material

Use the following guidelines for proper print material storage:

- For best results, store print material in an environment where the temperature is approximately 21°C (70°F) and the relative humidity is 40%.
- Store cartons of print material on a pallet or shelf, rather than directly on the floor.
- If you store individual packages of print material, make sure they rest on a flat surface so the edges do not buckle or curl.
- Do not place anything on top of the print material packages.

Loading Print Material

Proper print material loading helps prevent paper jams and helps make your printing trouble-free.

Do not remove input trays while a job is printing or while **Busy** displays on the operator panel. Doing so may cause a paper jam.

Before loading print material, know the recommended print side of the print material you are using. This information is usually indicated on the print material package.

Loading an Input Tray

Your printer has one standard 250-sheet input tray that holds five paper sizes: A4, B5, LTR (Letter), LGL (Legal), and EXE (Executive). The 250-sheet input tray also holds labels or transparencies.

You may purchase an optional 500-sheet drawer as a paper source. See “Optional 500-Sheet Drawer” on page 223 for installation information.

To load print material in an input tray:

1 Pull the input tray straight out of the printer.

If you are loading the 250-sheet input tray, pull the input tray straight out and remove it completely from the printer.

If you are loading the input tray for the optional 500-sheet drawer, pull the input tray straight out and remove it completely from the support unit.

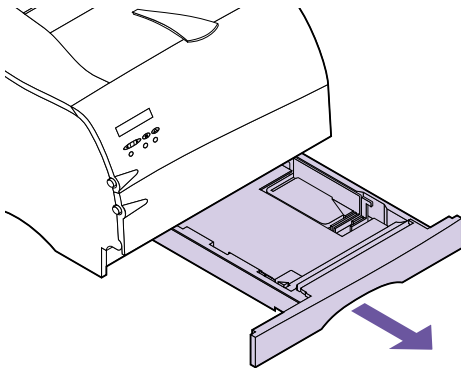

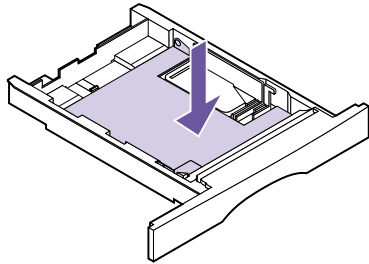

2 Press down on the metal plate until it locks into place.

The metal plate remains stationary on the inside bottom of the input tray.

3 Move the length guide to the correct position for the size print material you are loading.

- For the 250-sheet input tray, press down on the length guide tab with one hand, and with the other hand slide the length guide to the correct position for the size print material you are loading.

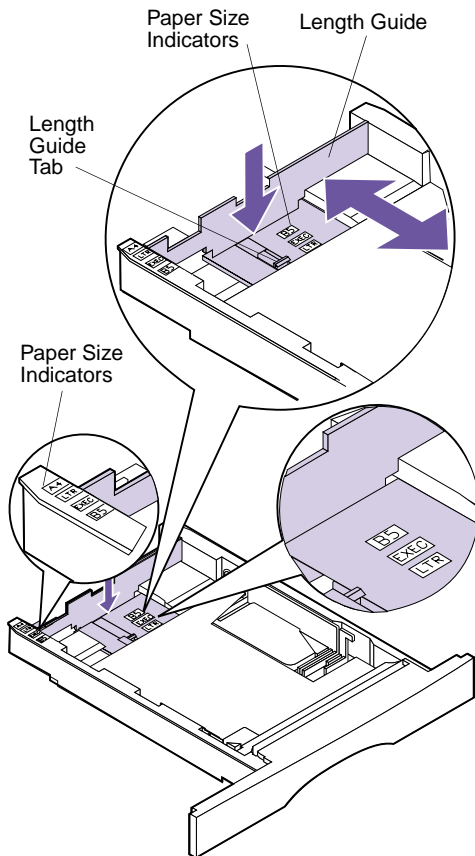

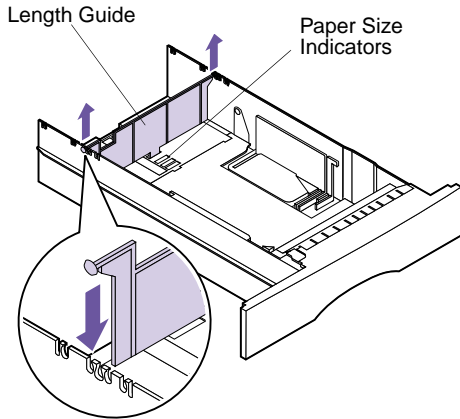

- For the 500-sheet input tray, lift the length guide straight up out of the input tray and replace it in the correct position.

Insert the tabs located on each end of the length guide into the slots on the side of the input tray.

Note: These examples show how to adjust for letter-size paper (LTR). The paper size indicators are paper size abbreviations used for placement of the length guide as shown.

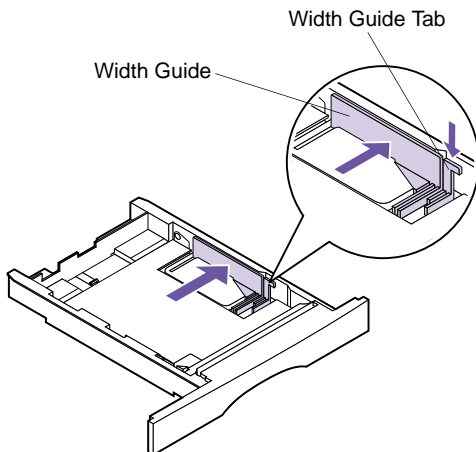

- 4** Press down on the width guide tab and slide the width guide to the far right side of the input tray as shown.

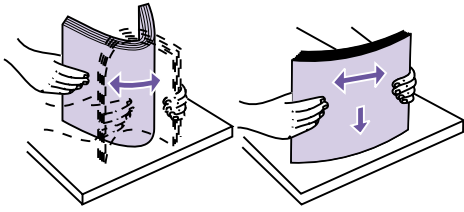

- 5 Flex the sheets back and forth to loosen them, then fan them.** Do not fold or crease the print material. Straighten the edges on a level surface.

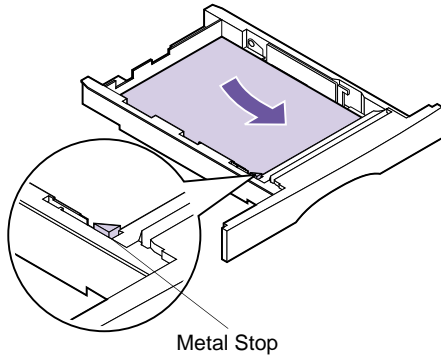

- 6 Place the print material against the left side of the input tray and insert it under the metal stop.**

Make sure the recommended print side is face down and the front edge is placed toward the front of the input tray.

For information on loading letterhead, see “Printing on Letterhead” on page 135.

Note: Make sure the print material fits easily under the metal stop and is not bent or wrinkled. Do not raise the metal stop or force print material under the metal stop.

- 7** Do not exceed the maximum stack height indicated by the line under the arrows.

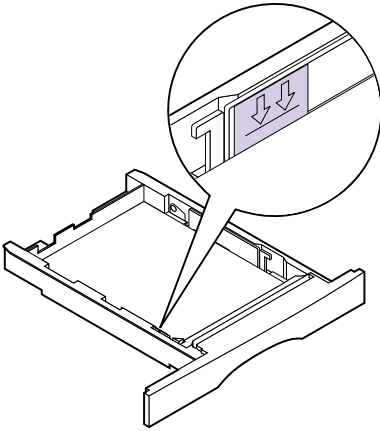

Note: Overfilling the input tray may cause paper jams.

- 8** Push on the right side of the width guide to move it to the left until it lightly touches the edge of the print material.

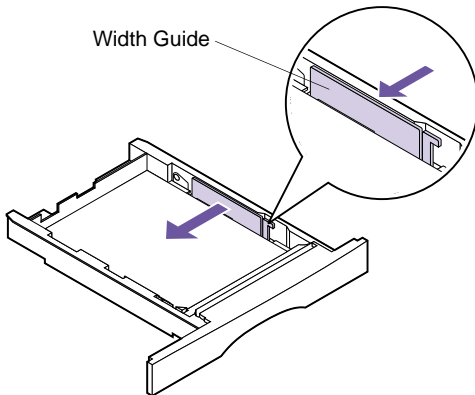

Note: Sliding the width guide too tight against the print material may cause misfeeds.

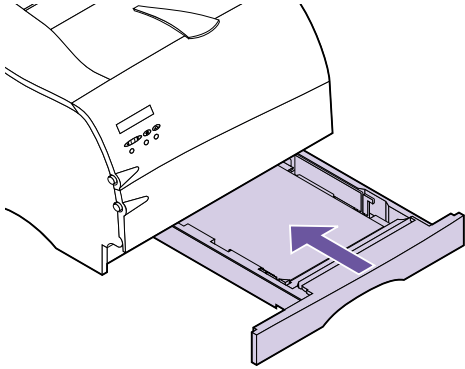

9 Insert the input tray.

Slide the input tray all the way into the printer until it *snaps* into place.

Slide the 500-sheet input tray all the way into the support unit.

If an error message displays, see “Understanding Printer Messages” on page 151.

10 Send your job to print.

For information on duplexing, see “Manual Duplex Printing” on page 136.

Loading the Multipurpose Feeder

Note: When printing from the multipurpose feeder, be sure to set the **PAPER SIZE** and **PAPER TYPE** for the **MP Feeder** menu item. Also select the paper size and type from your software application.

Your printer has one standard multipurpose feeder that holds several sizes and types of print material, such as paper, card stock, transparencies, postcards, note cards, and envelopes. You can load approximately 100 sheets of 75 g/m² (20 lb) paper at a time. You can also load approximately 10 envelopes or 20 transparencies at a time.

You may also want to use the multipurpose feeder for single page print jobs on letterhead or other special print material you do not keep in an input tray.

For information on the types of print material that you can use with the multipurpose feeder, see “Paper Sources and Sizes” on page 116. For more information about using the multipurpose feeder, see “Multipurpose Feeder” on page 139.

Complete the following instructions to load print material in the multipurpose feeder:

- 1 Open the multipurpose feeder door.** See “Opening the Multipurpose Feeder” on page 141 for more information.
- 2 Slide the paper width guide to the far right side of the multipurpose feeder.**

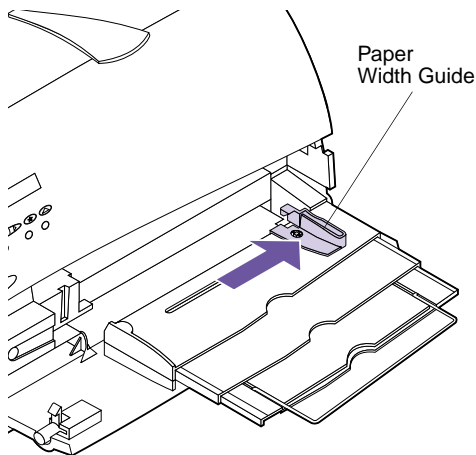

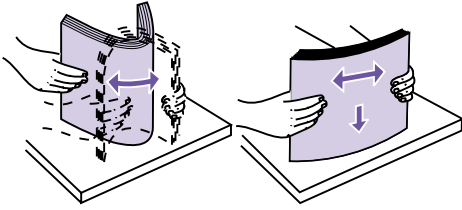

Note: Do not load different sizes or types of print material in the multipurpose feeder at the same time. Doing so may cause a paper jam.

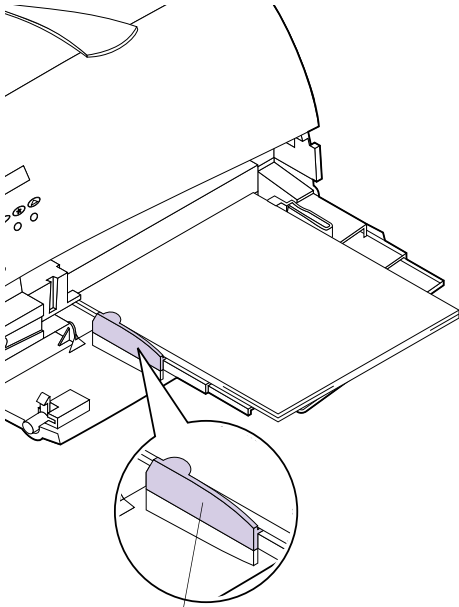

Stack Height Limiter

Note: Do not exceed the maximum stack height limiter located on the left side of the multipurpose feeder.

3 Flex the sheets back and forth to loosen them, then fan them. Do not fold or crease the print material. Straighten the edges on a level surface.

4 Locate the stack height limiter on the left side of the printer.

5 Place the print material against the left side of the multipurpose feeder with the recommended print side face up and the top edge going in first toward the printer.

- 6** Slide the print material into the multipurpose feeder as far as it will go. Do not force it. Forcing print material could cause a paper jam.

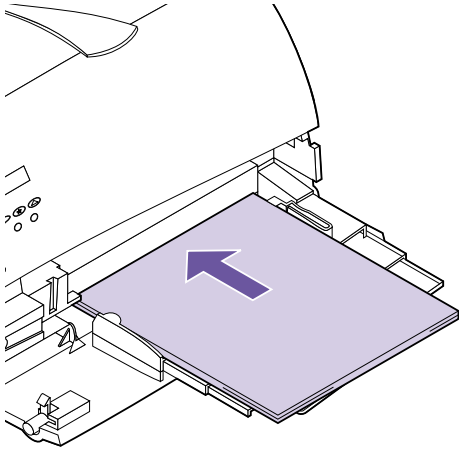

- 7** Slide the paper width guide to the left until it lightly touches the edge of the print material.

Make sure the print material fits loosely in the multipurpose feeder and is not bent or wrinkled. Do not overload the multipurpose feeder.

- 8** Send your job to print.

For information on duplexing, see “Manual Duplex Printing” on page 136.

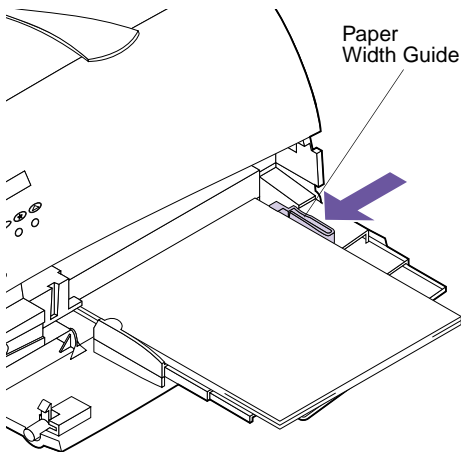

Using the Paper Exits (Output Bins)

Your printer has two standard paper exits. The following sections explain how to use the printer output bins.

Using the Standard Output Bin

The standard output bin holds 250 sheets of print material and is located on top of the printer. The printer automatically sends print jobs to the standard output bin.

The standard output bin collates print jobs face down.

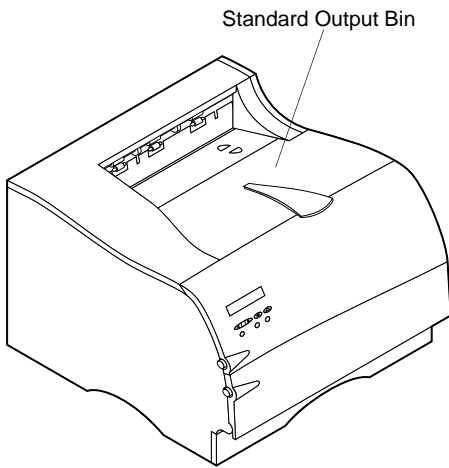

Using the Rear Output Bin

You may want to use the rear output bin when you print on different sizes and types of print material, such as paper, card stock, transparencies, postcards, note cards, and envelopes. The rear output bin holds 20 sheets of paper. For information on other types of print material, refer to the *Card Stock & Label Guide*.

Note: Print material that is 165.1 mm (6.5 in.) or less in length must exit to the rear output bin.

The printer automatically sends print jobs to the rear output bin when you open it. The rear output bin reverse collates print jobs face up.

1 Locate the rear output bin door as shown.

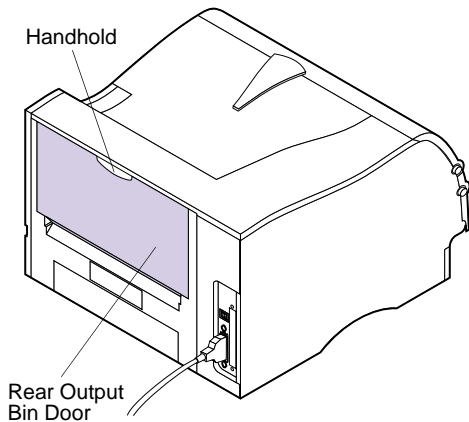

2 Pull the handhold to open the rear output bin.

3 Close the rear output bin door when you finish using it.

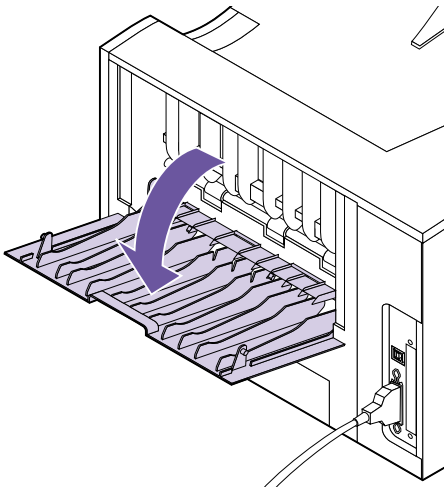

Printing on Letterhead

Check with the manufacturer or vendor to determine whether the preprinted letterhead you have chosen is acceptable for laser printers.

Page orientation is important when printing on letterhead. Use the following table for help when loading letterhead in the paper sources.

Orienting Letterhead

Tray	Print side	Top of page	
		Portrait	Landscape
Tray 1 (250-sheet input tray) Tray 2 (optional 500-sheet drawer)	Face down	Front of tray (nearest tray handle)	Left side of tray
Multipurpose feeder (including feeding individual sheets)	Face up	Rear of tray (enters the printer first)	Left side of tray

Tray Linking

If you are using the same size and type of print material in all paper sources (input trays and the multipurpose feeder) and the **PAPER MENU** settings for the sources are the same, the automatic tray linking feature is enabled. For example, if you have the same size and type print material loaded in the standard 250-sheet tray and the optional 500-sheet drawer, the printer will select print material from one tray when the other becomes empty.

If you load the same size print material in each tray, make sure the print material is all the same type. If you use different print material in the trays, each source with a different print material must have the **PAPER TYPE** set to a unique value to disable the automatic tray linking feature. See **PAPER TYPE** on page 47 for more information.

Manual Duplex Printing

Manual duplex printing lets you print on both sides of paper and card stock.

Manual duplexing does not damage your printer, but print quality and feed reliability may vary when printing on the other side of the page.

To print on both sides of paper and card stock (called *duplex printing* or *two-sided printing*), print the first side of the print material like any other print job. When printing on the other side of the page, set **PAPER WEIGHT** to **Heavy** in the **PAPER MENU** to achieve the best results.

Make sure the placement or orientation of the print material is correct.

Duplex Printing from the Multipurpose Feeder

When printing letterhead paper from the multipurpose feeder, load it with the design face up, so the top edge of the sheet with the logo enters the printer first.

To print the second side of the sheet, load the printed side face down with the top edge of the sheet facing toward the printer.

Duplex Printing from the Trays

When printing letterhead paper from the trays, load it with the design face down with the top edge of the sheet facing toward the front of the printer.

To print the second side of the sheet, load the printed side face up with the top edge of the sheet facing toward the front of the printer.

Avoiding Paper Jams

If you follow the tips outlined in “Print Material Guidelines” on page 118 and in “Loading Print Material” on page 124, you are well on your way to trouble-free printing. If jams do occur, however, follow the steps outlined in “Clearing Jams” on page 183. If jams occur frequently, make sure you are following these tips:

Note: Make sure the **PAPER TYPE**, **PAPER TEXTURE**, and **PAPER WEIGHT** settings in the **PAPER MENU** are correct.

- Use only recommended print materials. See “Print Material Guidelines” on page 118.
- If you need to load print material in a tray while a job is printing, press the **Stop** button and wait for the printer motors to idle before you remove the tray from the printer. After you reinstall the loaded tray, press **Go** to continue printing.
- Do not load wrinkled, creased, damp, or curled print material.
- Flex, fan, and straighten the print material before you load it. If jams do occur, try manually feeding the print material one sheet at a time.
- Do not overload the paper sources. Make sure the print material does not exceed the maximum height indicated on the stack height indicator.
- Do not use print material that you have cut or trimmed yourself.
- Do not mix print material sizes, weights, or types in the same paper source.
- Do not use coated print materials.
- Make sure the recommended print side is face down when loading all input trays and the recommended print side is face up when loading the multipurpose feeder.
- Keep print materials stored in an acceptable environment. See “Storing Print Material” on page 123.
- Do not remove input trays during a print job.

5

Multipurpose Feeder

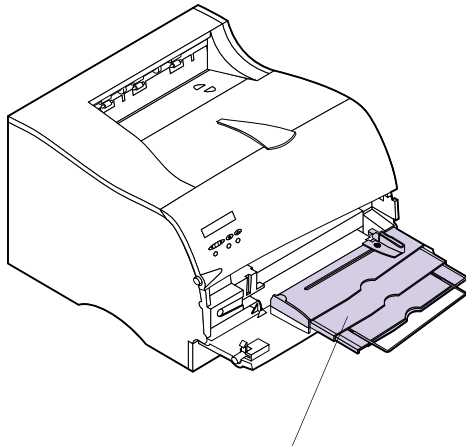

Multipurpose Feeder

The multipurpose feeder is located on the front of your printer. It can be closed when you are not using it, making the printer more compact.

You may want to use the multipurpose feeder when you print on different sizes and types of print material, such as paper, card stock, transparencies, postcards, note cards, and envelopes. You may also want to use the multipurpose feeder for single-page print jobs on letterhead, or other special print material you do not keep in a paper tray.

You can load approximately 100 sheets of 75 g/m² (20 lb) print material at a time. You can load approximately 10 envelopes or 20 transparencies at a time.

The maximum stack height for the loading of any print material is 10 mm (0.4 in.). Print material is loaded face up in the multipurpose feeder.

The multipurpose feeder accepts print material within the following dimensions:

	Minimum	Maximum
Width	69.85 mm (2.75 in.)	229.11 mm (9.02 in.)
Length	127 mm (5 in.)	355.6 mm (14 in.)

When printing from the multipurpose feeder, be sure to set the **PAPER SIZE** and **PAPER TYPE** for the **MP Feeder** menu item. Also, select the size and paper type from your software application for the print material you have loaded. See **PAPER SIZE** on page 45 and **PAPER TYPE** on page 47 for more information.

Multipurpose Feeder Guidelines

Follow these guidelines when using the multipurpose feeder:

- Load only one size and type of print material or envelopes at a time in the multipurpose feeder.
- To achieve the best possible print quality, use only high-quality print material that is designed for use in laser printers. See “Using Print Materials” on page 115 for guidelines on selecting types of print material.
- To prevent paper jams, do not add print material to the multipurpose feeder until it is empty.
- Do not close the multipurpose feeder while a job is printing or while **Busy** displays on the operator panel. Doing so may cause a paper jam.
- Load print material with the top edge going into the multipurpose feeder first.
- Do not place objects on the multipurpose feeder. Also, avoid pressing down or applying excessive force on it.

Opening the Multipurpose Feeder

To open the multipurpose feeder door:

- 1 Push the lower release latch on the front left side to release the multipurpose feeder door.**

The multipurpose feeder door is the same as the lower front door.

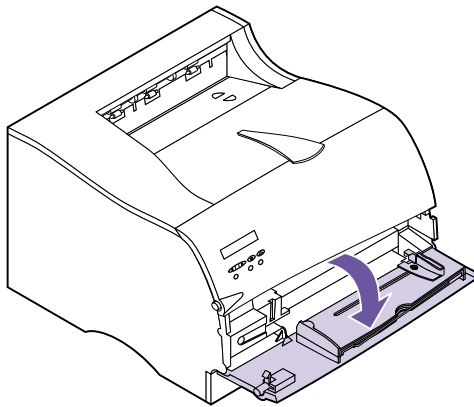
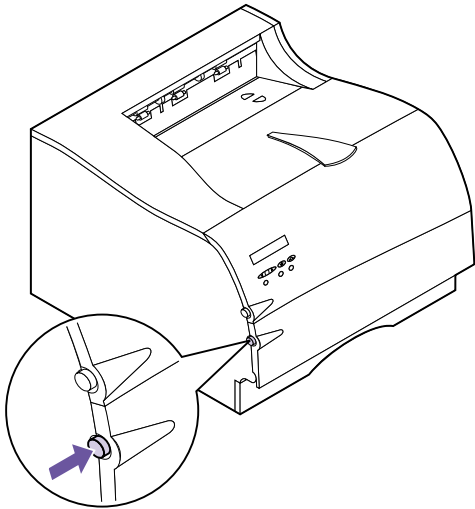

The multipurpose feeder door opens and stops in place.

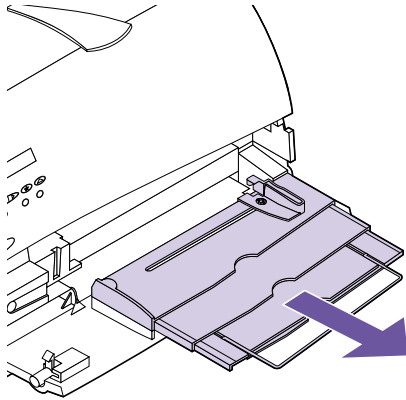

- 2** Locate the metal bar in the recessed area on the multipurpose feeder.
- 3** Pull the metal bar straight out to extend the multipurpose feeder.

Note: Extend the metal bar to its full-length position to hold longer print material.

Loading the Multipurpose Feeder

Proper loading prevents paper jams and ensures trouble-free printing. The following sections give detailed instructions for loading.

Note: Note the recommended print side label on the print material package and load print material accordingly.

Loading Print Material

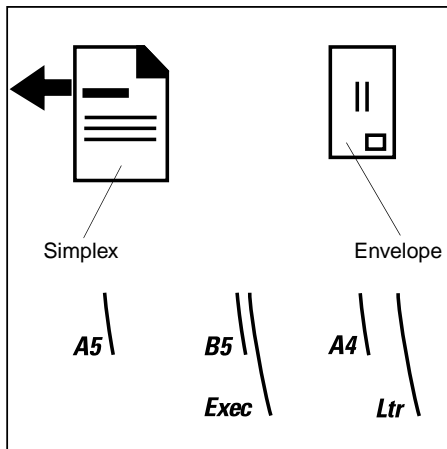

- 1 **Locate the icons on the multipurpose feeder surface.** These icons show the correct orientation for loading paper, as well as how to load letterhead and envelopes.

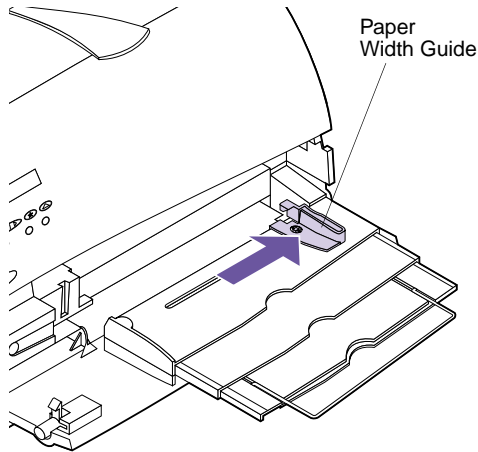

2 Slide the paper width guide to the far right side of the multipurpose feeder.

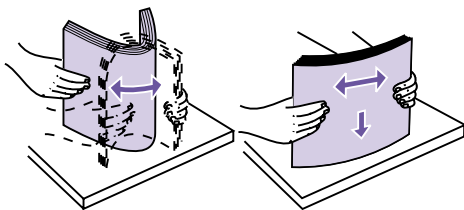

3 Prepare specific print material for loading:

- Flex sheets of paper back and forth to loosen them, and then fan them. Do not fold or crease the paper. Straighten the edges on a level surface.

- Hold transparencies by the edges and fan them to prevent feeding failures.

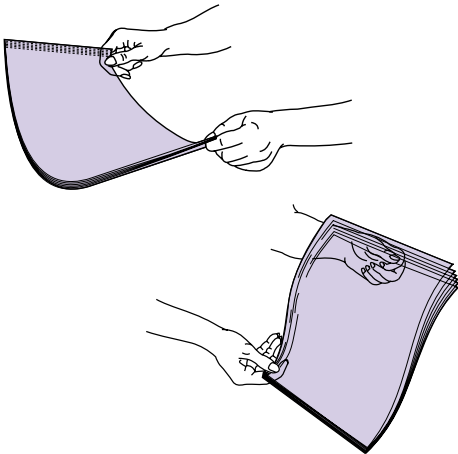

Note: Avoid touching the print side of the transparencies. Be careful not to scratch them.

- Fan envelopes back and forth to loosen them. Do not fold or crease the envelopes. Straighten the edges on a level surface.

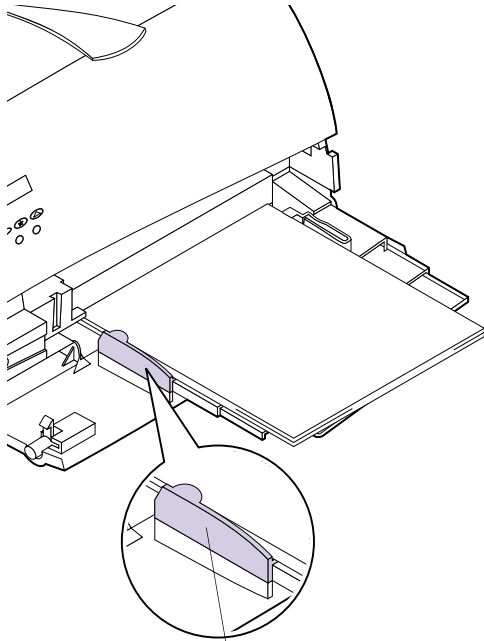
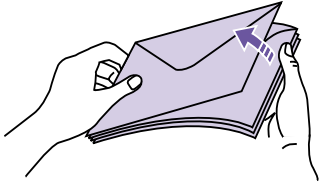

Stack Height Limiter

- 4** Locate the stack height limiter on the left side of the multipurpose feeder.
- 5** Place the print material against the left side of the multipurpose feeder. Do not mix different sizes and types of print material.

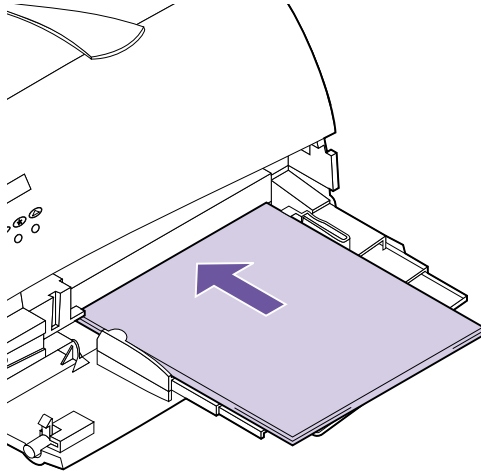

6 Load specific print material:

- Load paper with the recommended print side face up and the top edge going in first as shown.

Note: Do not exceed the maximum stack height limiter located on the left side of the multipurpose feeder. Overfilling the multipurpose feeder may cause paper jams.

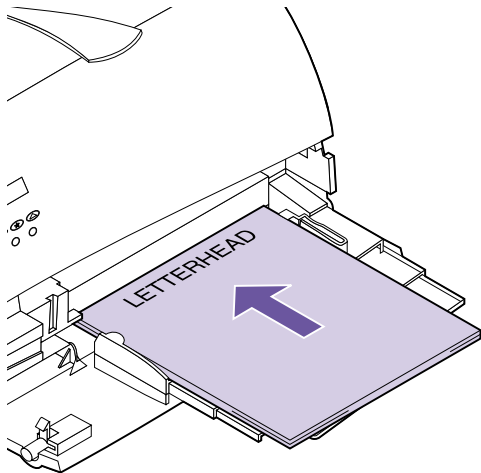

- Load letterhead with the design face up and the top edge going in first as shown.

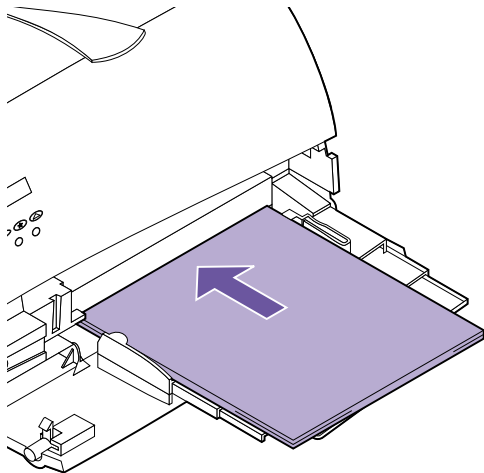

- Load transparencies with the recommended print side face up and the top edge going in first as shown.

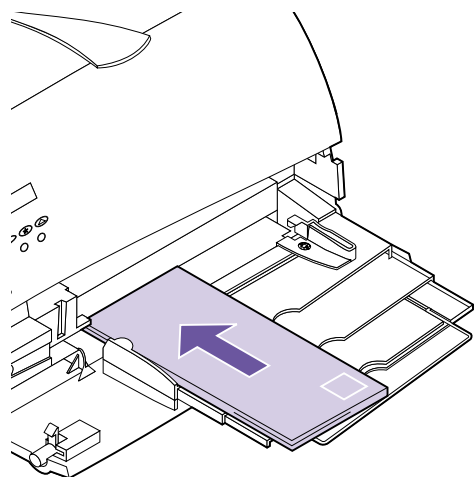

- Load envelopes with the flap side down and the stamp area end going in last as shown.

Do not feed stamped envelopes into the multipurpose feeder. The stamp is shown for placement only.

Note: For best results, self-sealing envelopes should exit to the rear output bin.

Warning! Never use envelopes with clasps, snaps, windows, coated linings, or self-stick adhesives. These envelopes may severely damage the printer.

- 7** Slide the print material into the multipurpose feeder as far as it will go. Do not force it. Forcing print material could cause a paper jam.

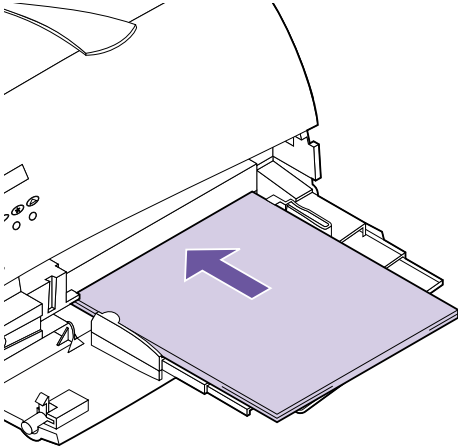

Note: If envelopes jam while printing, try reducing the number of envelopes you load.

- 8** Slide the paper width guide to the left until it lightly touches the edge of the print material.

Make sure the print material fits loosely in the multipurpose feeder and is not bent or wrinkled. Do not overload the multipurpose feeder.

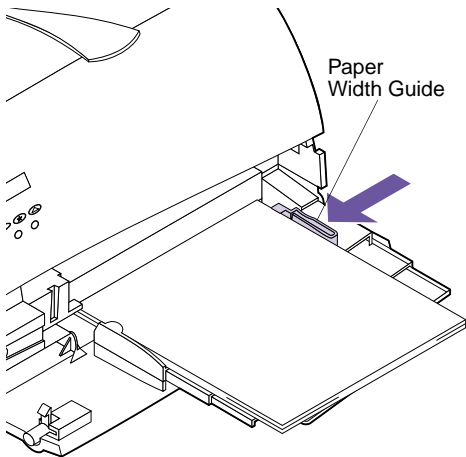

Using the Multipurpose Feeder

Note: Software settings may override operator panel settings.

After loading print material in the multipurpose feeder, select the paper source from your software application, and then select the paper size and type from both your software application and from the operator panel.

To set the operator panel:

- 1 Make sure the PAPER SIZE for the multipurpose feeder (MP Feeder Size) is set to the correct size for the print material you are loading.**
- 2 Make sure the PAPER TYPE for the multipurpose feeder (MP Feeder Type) is set to the correct value for the print material you are loading.**
- 3 Make sure the PAPER LENGTH for the PAPER TYPE in the multipurpose feeder is set to the correct value for the print material you are loading.**

Print material 152.4 mm (6 in.) or less in length must exit to the rear output bin. See “Using the Rear Output Bin” on page 134 for more information.

- 4 Press Go to return the printer to the Ready state.**

Closing the Multipurpose Feeder

When you finish printing with the multipurpose feeder:

1 Remove all print material.

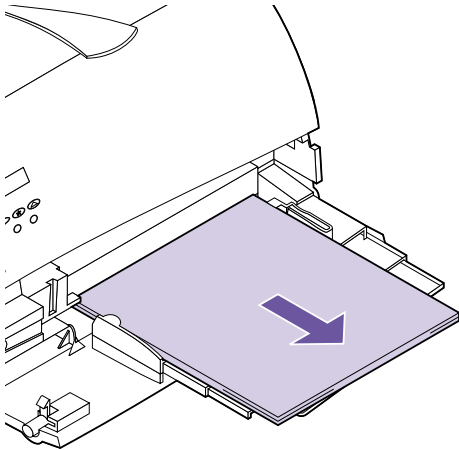

2 Push the metal bar straight back to collapse the multipurpose feeder to its short-length position.

3 Close the multipurpose feeder door.

4 Close the rear output bin if you were printing on print material 152.4 mm (6 in.) or less in length. See page 134 for more information.

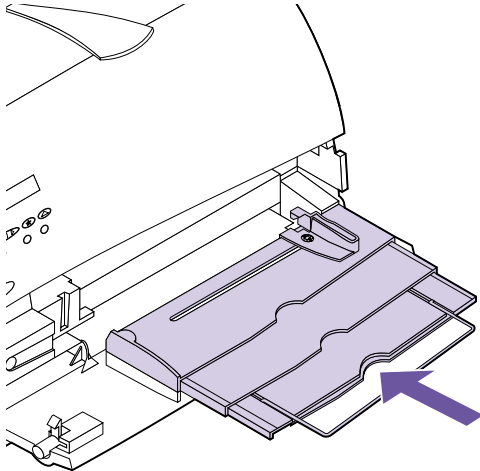

Understanding Printer Messages

6

This chapter describes the various messages that may appear on your operator panel display. *Status messages* give information about the current state of the printer. *Attendance messages* indicate printer errors that you must resolve. *Service messages* indicate printer failures that may require servicing.

Note: For documentation purposes, Print and Hold jobs refers to any of the following jobs: Confidential Job, Reserve Print Job, Repeat Print Job, and Verify Print Job.

Status Messages

The first line (line 1) on the display provides information on the current state or status of the printer, as shown in the tables beginning on page 152. However in some cases, a message is long enough that it requires both lines to display the entire message.

Usually the second line (line 2) on the display provides additional information about printer status. See “Warning Messages” on page 158 for more information.

Line 1 Messages

Status Message	Meaning and Actions Allowed While Message Displays
Activating Menu Changes	<p>The printer is reset to activate a printer setting change.</p> <p>No button actions are possible while this message displays.</p>
Busy <warning>	<p>The printer is busy receiving, processing, or printing data. The printer indicator light blinks while the printer is processing data.</p> <p>The display shows one of the following items on line 1 while the printer processes data:</p> <ul style="list-style-type: none"> • A PJI RDYMSG, if it is defined • A Network Printing Alliance (NPA) protocol job name, if one is defined • The printer language <p>Note: If you use a PJI RDYMSG command or an NPA protocol job name, a customized message may display instead of Busy.</p> <p>Note: The printer language appears on line 1 to the right of the Busy message.</p> <ul style="list-style-type: none"> • Press Stop to take the printer out of the Busy state. The Not Ready message displays. No more data is processed, but all print material in the printer paper path prints. Press Go to return to Busy and continue receiving, processing, or printing data. • Cancel the current job. Press Menu> or <Menu. The JOB MENU displays. Press Menu> or <Menu until Cancel Job appears on the second line of the operator panel display. Press Select. • Reset the printer. Press Menu> or <Menu. The JOB MENU displays. Press Menu> or <Menu until Reset Printer appears on the second line of the operator panel display. Press Select. • Print or delete Print and Hold jobs. Press Menu> or <Menu. The JOB MENU displays. Press Menu> or <Menu until CONFIDENTIAL JOB or HELD JOBS appears. Continue with the instructions for CONFIDENTIAL JOB on page 60 or HELD JOBS on page 65 to print all jobs, print a job, print copies, delete all jobs, or delete a job. <p>For more information, refer to the <i>Technical Reference</i>.</p> <p>Note: Resetting the printer deletes all current data from the print buffer, including all Print and Hold jobs. See Reset Printer on page 70 for more information.</p> <p>Warning messages are displayed on line 2 of the operator panel. See "Warning Messages" on page 158 for more information.</p>
Cancelling Job	<p>The printer is processing a request to cancel the current print job.</p>
Clearing Job Accounting Stat	<p>The printer is deleting all job statistics stored on the hard disk option.</p> <p>No button actions are possible while this message displays.</p>
Defragmenting DO NOT POWER OFF	<p>The printer is defragmenting the flash memory option to reclaim storage space occupied by deleted resources.</p> <p>No button actions are possible while this message displays.</p>

Status Message	Meaning and Actions Allowed While Message Displays
<p>Deleting Jobs</p> <p>Queuing and Deleting Jobs</p>	<p>The printer is deleting one or more Print and Hold jobs. This message displays if you selected Delete All Jobs or DELETE A JOB, and there are no other print jobs selected for printing.</p> <p>The printer is deleting one or more Print and Hold jobs and printing one or more Print and Hold jobs. This message displays if one or more print jobs are selected for deletion in the CONFIDENTIAL JOB and HELD JOBS menu items, and one or more print jobs are selected for printing.</p> <p>No button actions are possible while either of these messages displays.</p> <p>See Delete All Jobs on page 63 and on page 68 or DELETE A JOB on page 63 and on page 68 for more information.</p>
<p>Disabling Menus</p>	<p>This message briefly displays after the operator panel menus have been disabled. See “Disabling the Operator Panel Menus” on page 41 for more information.</p> <p>No button actions are possible while this message displays.</p>
<p>Enabling Menus</p>	<p>If the operator panel menus are disabled, this message briefly displays after they are enabled. See “Disabling the Operator Panel Menus” on page 41 for more information.</p> <p>No button actions are possible while this message displays.</p>
<p>Flushing Buffer</p>	<p>The printer is flushing corrupted print data and discarding the current print job.</p> <p>No button actions are possible while this message displays.</p>
<p>Formatting Disk</p>	<p>The hard disk option is formatting.</p> <p>This message also displays if you select the Discard value for the Buffered Jobs menu item in the CONFIG MENU.</p> <p>No button actions are possible while this message displays.</p> <p>Note: Do not power Off (O) the printer while this message displays.</p>
<p>Formatting Flash DO NOT POWER OFF</p>	<p>The flash memory option is formatting.</p> <p>No button actions are possible while this message displays.</p> <p>Note: Do not power Off (O) the printer while this message displays.</p>
<p>Invalid Network 1 Code</p>	<p>This message displays if the code in the optional internal print server (also called an internal network adapter or INA) has not been programmed or if the code is not valid. You can download network code while this message displays.</p> <p>When this message appears, the Ready and Busy messages do not display until valid code is programmed into the optional internal print server.</p> <p>No button actions are possible while this message displays.</p>
<p>Menus Disabled</p>	<p>The printer menus are disabled. This message displays when Menu> or <Menu is pressed.</p> <p>See “Disabling the Operator Panel Menus” on page 41 for more information.</p> <p>No button actions are possible while this message displays.</p>

Status Message	Meaning and Actions Allowed While Message Displays
Network Card Busy	<p>The optional internal print server is being reset. The Network 1 Setup menu item in the NETWORK MENU is not available while this message displays.</p> <p>No button actions are possible while this message displays.</p>
Not Ready	<p>The printer is in the Not Ready state, which means it is not ready to receive or process data.</p> <ul style="list-style-type: none"> • Press Go to take the printer out of the Not Ready state. • Cancel the current job. Press Menu> or <Menu. The JOB MENU displays. Press Menu> or <Menu until Cancel Job appears on the second line of the operator panel display. Press Select. • Reset the printer. Press Menu> or <Menu. The JOB MENU displays. Press Menu> or <Menu until Reset Printer appears on the second line of the operator panel display. Press Select. <p>Note: Resetting the printer deletes all current data from the print buffer, including all Print and Hold jobs. See Reset Printer on page 70 for more information.</p>
Performing Self Test	<p>The printer is running the normal series of start-up tests after it is powered On (I).</p> <p>When the tests are complete, the printer returns to the Ready state.</p> <p>No button actions are possible while this message display.</p>
Power Saver <warning>	<p>The printer is in Power Saver mode.</p> <ul style="list-style-type: none"> • Press Go to take the printer out of Power Saver mode. • Press Menu> or <Menu to enter the menus. • Press Stop to take the printer offline. The Not Ready message displays. No data is processed. Press Go to return the printer to Power Saver. <p>Warning messages are displayed on line 2 of the operator panel. See "Warning Messages" on page 158 for more information.</p>

Status Message	Meaning and Actions Allowed While Message Displays
<p>Printing Directory List</p> <p>Printing Font List</p> <p>Printing Job Accounting Stat</p> <p>Printing Menu Settings</p>	<p>The printer is processing or printing a directory of all files stored in the flash memory option or on the hard disk option.</p> <p>The printer is processing or printing a list of all available fonts for the selected printer language.</p> <p>The printer is processing or printing the Job Accounting Statistics.</p> <p>The printer is processing or printing the menu settings page. See “Printing the Menu Settings Page” on page 39 for more information.</p> <p>The message displays until the function completes and the page prints.</p> <ul style="list-style-type: none"> • Press Stop to take the printer offline. The Not Ready message displays. No more data is processed, but all print material in the printer paper path prints. Press Go to return to the previous message. • Cancel the current job. Press Menu> or <Menu. The JOB MENU displays. Press Menu> or <Menu until Cancel Job appears on the second line of the operator panel display. Press Select. • Reset the printer. Press Menu> or <Menu. The JOB MENU displays. Press Menu> or <Menu until Reset Printer appears on the second line of the operator panel display. Press Select. <p>Note: Resetting the printer deletes all current data from the print buffer, including all Print and Hold jobs. See Reset Printer on page 70 for more information.</p>
<p>Printing Quality Test Pages</p>	<p>The printer is formatting the Print Quality Test Pages once Prt Quality Pgs is selected in the CONFIG MENU. Once the pages start printing, the Busy message displays.</p> <p>No button actions are possible while this message displays.</p> <p>For more information about these pages, see Prt Quality Pgs on page 106.</p>
<p>Program Flash DO NOT POWER OFF</p>	<p>The printer is storing resources, fonts or macros, in the flash memory option. If information is written to the flash memory option and to the hard disk option at the same time, the Program Flash message displays.</p> <p>No button actions are possible while this message displays.</p> <p>Note: Do not power Off (O) the printer while this message displays.</p>
<p>Programming Disk DO NOT POWER OFF</p>	<p>The printer is storing resources, fonts or macros, on the hard disk option. If information is written to the flash memory option and to the hard disk option at the same time, the Program Flash message displays.</p> <p>No button actions are possible while this message displays.</p> <p>Note: Do not power Off (O) the printer while this message displays.</p>

Status Message	Meaning and Actions Allowed While Message Displays
<p>Queuing Jobs</p> <p>Queuing and Deleting Jobs</p>	<p>The printer is processing one or more Print and Hold jobs selected for printing. This message displays if you selected PRINT A JOB, Print All Jobs, or PRINT COPIES and no jobs are selected for deletion.</p> <p>The printer is processing one or more Print and Hold jobs selected for printing and deleting one or more Print and Hold jobs. This message displays if you selected one or more jobs to print using PRINT A JOB, Print All Jobs, or PRINT COPIES values in the CONFIDENTIAL JOB or HELD JOBS menu items, and one or more jobs are selected for deletion.</p> <p>No button actions are possible while either of these messages displays.</p> <p>See PRINT A JOB on page 62 and on page 67, Print All Jobs on page 62 and on page 67, or PRINT COPIES on page 64 and on page 69 for more information.</p>
<p>Ready <warning></p>	<p>The printer is ready to receive and process data.</p> <ul style="list-style-type: none"> • Press Menu> or <Menu to take the printer out of the Ready state and enter the menus. • Press Stop to take the printer offline. The Not Ready message displays. No data is processed. Press Go to return the printer to the Ready state. <p>Note: If you use the PJJ RDYMSG command, a customized message may display instead of Ready.</p> <p>Note: If Power Saver is set to On and is active, Power Saver displays instead of Ready. See Power Saver on page 154 for more information.</p> <p>For more information, refer to the <i>Technical Reference</i>.</p> <p>Warning messages are displayed on line 2 of the operator panel. See “Warning Messages” on page 158 for more information.</p>
<p>Ready Hex <warning></p>	<p>The printer is ready and Hex Trace mode is active. Hex Trace isolates the source of a print job problem. When Hex Trace is selected, all data sent to the printer prints in hexadecimal and character representation. Control codes print, but do <i>not</i> execute.</p> <ul style="list-style-type: none"> • Power Off (O) the printer to exit Hex Trace. • Press Stop to take the printer offline. The Not Ready message displays, and no data is processed. Press Go to return the printer to the Ready state. • Reset the printer. Press Menu> or <Menu. The JOB MENU displays. Press Menu> or <Menu until Reset Printer appears on the second line of the operator panel display. Press Select. <p>Note: Resetting the printer deletes all current data from the print buffer, including all Print and Hold jobs. See Reset Printer on page 70 for more information.</p> <p>Warning messages are displayed on line 2 of the operator panel. See “Warning Messages” on page 158 for more information.</p>

Status Message	Meaning and Actions Allowed While Message Displays
Res Reduced <warning>	<p>The resolution of the page is reduced from 600 dots per inch (dpi) to 300 dpi to prevent a 38 Memory Full error. Res Reduced displays for the duration of the current job. The printer indicator light blinks while the printer is processing data.</p> <ul style="list-style-type: none"> • Press Stop to take the printer out of the Res Reduced state. The Not Ready message displays. Press Go to return to Res Reduced. • Cancel the current job. Press Menu> or <Menu. The JOB MENU displays. Press Menu> or <Menu until Cancel Job appears on the second line of the operator panel display. Press Select. <p>Warning messages are displayed on line 2 of the operator panel. See "Warning Messages" on page 158 for more information.</p>
Resetting the Printer	<p>The printer is deleting any print jobs in process and restoring all printer settings to user defaults.</p> <p>No button actions are possible while this message displays.</p>
Restoring Factory Defaults	<p>The printer is restoring factory defaults. Factory defaults are restored by selecting Factory Defaults in the UTILITIES MENU or by selecting Factory Defaults in the CONFIG MENU.</p> <p>See page 57 or page 107 for details about which printer settings are affected.</p> <p>No button actions are possible while this message displays.</p>
Waiting <warning>	<p>Waiting displays when one of the following occurs:</p> <ul style="list-style-type: none"> • The printer has received a page of data to print, but is waiting for an End of Job command, Form Feed command, or for additional data. Waiting displays until the Print Timeout occurs or additional data is received. • When Collation is set to On, but the print job has not been canceled. Termination of the print job is required before page collated copies print. <p>Note: The printer language appears on line 1 to the right of the Waiting message.</p> <ul style="list-style-type: none"> • Press Go to print the contents of the buffer. • Press Stop to take the printer out of the Waiting state. The Not Ready message displays. Press Go to return to Waiting. • Cancel the current job. Press Menu> or <Menu. The JOB MENU displays. Press Menu> or <Menu until Cancel Job appears on the second line of the operator panel display. Press Select. • Reset the printer. Press Menu> or <Menu. The JOB MENU displays. Press Menu> or <Menu until Reset Printer appears on the second line of the operator panel display. Press Select. <p>Note: Resetting the printer deletes all current data from the print buffer, including all Print and Hold jobs. See Reset Printer on page 70 for more information.</p> <p>Warning messages are displayed on line 2 of the operator panel. See "Warning Messages" on page 158 for more information.</p>

Warning Messages

Warning messages give further information about printer status. The following is an example of a warning message displayed on the operator panel when the printer is in the Ready state:



In this example, **Tray 1 Missing** is the warning message.

The following table lists messages that appear on the second line of the operator panel display. If none of the following conditions exist, line 2 of the operator panel display is blank.

Status Message	Meaning
Fax 1	The printer is processing a fax through the optional interface.
Infrared 1	The optional infrared interface is the active communication link.
LocalTalk 1	The optional LocalTalk interface is the active communication link.
Network 1	The optional network interface is the active communication link.
Parallel	The standard parallel interface is the active communication link.
Parallel 1	The optional parallel interface is the active communication link.
Serial 1	The optional serial interface is the active communication link.
Tray 1 Missing	The 250-sheet input tray is missing. Tray 1 Missing is available only if the optional 500-sheet drawer is installed. See "Optional 500-Sheet Drawer" on page 223 for more information.
USB	The standard USB interface is the active communication link.
USB 1	The optional USB interface is the active communication link.

Attendance Messages

Attendance messages indicate printer errors that you must resolve before you can continue printing. The messages are listed in numerical then alphabetical order.

Note: For paper jam errors, the entire paper path must be cleared of print material. See “Clearing Jams” on page 183 for more information.

Attendance Message	Meaning and Required Action
34 Short Paper	<p>The printer determines the paper length is too short to print the formatted data. This occurs when the printer does not know the actual paper size loaded in tray. This message also displays if you select Universal as a Paper Size setting and use print material too short for the page format.</p> <ul style="list-style-type: none"> • Press Go to clear the message and continue printing. • Make sure the Paper Size setting in the PAPER MENU is correct for the size print material you are using. If the MP Feeder Size setting is set to Universal, make sure your print material is large enough. • Cancel the current job. Press Menu> or <Menu. The JOB MENU displays. Press Menu> or <Menu until Cancel Job appears on the second line of the operator panel display. Press Select. • Reset the printer. Press Menu> or <Menu. The JOB MENU displays. Press Menu> or <Menu until Reset Printer appears on the second line of the operator panel display. Press Select. <p>Note: Resetting the printer deletes all current data from the print buffer, including all Print and Hold jobs. See Reset Printer on page 70 for more information.</p>
35 Res Save Off Deficient Memory	<p>The printer lacks the memory needed to enable Resource Save. This message usually indicates that too much memory is allocated for one or more of the printer link buffers.</p> <p>To enable Resource Save after this message displays:</p> <ul style="list-style-type: none"> • Install additional memory, <i>or</i> • Set the link buffer back to Auto, and exit the menus to activate the link buffer changes. When Ready displays, enable Resource Save from the SETUP MENU. <p>Press Go to disable Resource Save and continue printing.</p>

Attendance Message	Meaning and Required Action
37 Insufficient Collation Area	<p>The printer memory used to store pages of data is too full to collate the rest of the print job.</p> <ul style="list-style-type: none"> • Press Go to clear the message, print the portion of the job already in memory, and begin collating the rest of the job. • Cancel the current job. Press Menu> or <Menu. The JOB MENU displays. Press Menu> or <Menu until Cancel Job appears on the second line of the operator panel display. Press Select. • Reset the printer. Press Menu> or <Menu. The JOB MENU displays. Press Menu> or <Menu until Reset Printer appears on the second line of the operator panel display. Press Select. <p>Note: Resetting the printer deletes all current data from the print buffer, including all Print and Hold jobs. See Reset Printer on page 70 for more information.</p>
37 Insufficient Defrag Memory	<p>The printer memory used to store undeleted flash resources is too full to perform the flash memory defragment operation.</p> <ul style="list-style-type: none"> • Press Go to clear the message. <p>To perform the defragment operation, you can:</p> <ul style="list-style-type: none"> • Delete fonts, macros, and other data in printer RAM. • Install additional printer memory.
37 Insufficient Memory Held Jobs may be lost. Go/Stop?	<p>The printer memory contains Print and Hold jobs, and is too full to continue processing the current job.</p> <p>Note: The messages, 37 Insufficient Memory and Held Jobs may be lost. Go/Stop?, display alternately on the operator panel until you do one of the following:</p> <ul style="list-style-type: none"> • Press Go to clear the messages and continue printing the current job. The printer frees memory by deleting all Print and Hold jobs. If the current job is a Print and Hold job, it is not deleted. • Press Stop to clear the messages and continue printing the job. However, some data may not print or may not print correctly. • Cancel the current job. Press Menu> or <Menu. The JOB MENU displays. Press Menu> or <Menu until Cancel Job appears on the second line of the operator panel display. Press Select. • Reset the printer. Press Menu> or <Menu. The JOB MENU displays. Press Menu> or <Menu until Reset Printer appears on the second line of the operator panel display. Press Select. <p>Note: Resetting the printer deletes all current data from the print buffer, including all Print and Hold jobs. See Reset Printer on page 70 for more information.</p>

Attendance Message	Meaning and Required Action
38 Memory Full	<p>The printer is processing data, but the memory used to store pages is full.</p> <ul style="list-style-type: none"> • Press Go to clear the message and continue printing the job. However, some data may not print or may not print correctly. • Cancel the current job. Press Menu> or <Menu. The JOB MENU displays. Press Menu> or <Menu until Cancel Job appears on the second line of the operator panel display. Press Select. • Reset the printer. Press Menu> or <Menu. The JOB MENU displays. Press Menu> or <Menu until Reset Printer appears on the second line of the operator panel display. Press Select. <p>Note: Resetting the printer deletes all current data from the print buffer, including all Print and Hold jobs. See Reset Printer on page 70 for more information.</p> <p>After resetting the printer, reduce the complexity of the print job and send it to print again. To simplify the print job:</p> <ul style="list-style-type: none"> • Reduce the amount of text or graphics on a page. • Reduce the print resolution. • Delete unnecessary downloaded fonts or macros. <p>Install additional printer memory to avoid future 38 Memory Full errors.</p>
39 Complex Page	<p>The page may not print correctly because the amount of text, graphics, or print information on the page is very complex.</p> <ul style="list-style-type: none"> • Set Page Protect in the SETUP MENU to On and send the print job again. • Press Go to clear the message and continue printing the job. However, some data may not print or may not print correctly. Try to simplify the print job. • Cancel the current job. Press Menu> or <Menu. The JOB MENU displays. Press Menu> or <Menu until Cancel Job appears on the second line of the operator panel display. Press Select. • Reset the printer. Press Menu> or <Menu. The JOB MENU displays. Press Menu> or <Menu until Reset Printer appears on the second line of the operator panel display. Press Select. <p>Note: Resetting the printer deletes all current data from the print buffer, including all Print and Hold jobs. See Reset Printer on page 70 for more information.</p>
51 Defective Flash	<p>The printer detects a defective flash memory option. This message appears when you power On (!) the printer, or during format and write to flash operations.</p> <p>Press Go to clear the message and continue printing. You must install a different flash memory option before you can perform any flash memory operations.</p>

Attendance Message	Meaning and Required Action
<p>52 Flash Full</p>	<p>There is not enough free space in the flash memory option to store the data that was sent.</p> <ul style="list-style-type: none"> • Press Go to clear the message and continue printing. Downloaded fonts and macros not previously stored in flash memory are deleted. • Cancel the current job. Press Menu> or <Menu. The JOB MENU displays. Press Menu> or <Menu until Cancel Job appears on the second line of the operator panel display. Press Select. • Reset the printer. Press Menu> or <Menu. The JOB MENU displays. Press Menu> or <Menu until Reset Printer appears on the second line of the operator panel display. Press Select. <p>Note: Resetting the printer deletes all current data from the print buffer, including all Print and Hold jobs. See Reset Printer on page 70 for more information.</p>
<p>53 Unformatted Flash</p>	<p>The printer detects an unformatted flash memory option. This message appears when you power On (I) the printer.</p> <p>You must format the flash memory option before you can perform any flash memory operations. To format the flash memory option, select Format Flash from the UTILITIES MENU.</p> <p>Press Go to clear the message and continue printing. If the error message remains, the flash memory option may be defective and need replacing.</p>

Attendance Message	Meaning and Required Action
<p>54 Serial Option 1 Error</p> <p>54 Std Par ENA Connection Lost</p> <p>54 Par 1 ENA Connection Lost</p> <p>54 Ser 1 Fax Connection Lost</p> <p>54 Network 1 Software Error</p>	<p>A serial interface error is detected (framing or parity) on the optional serial port. This error usually indicates the serial link has not been set up correctly. When the serial error displays, the reporting of other serial errors is suppressed until interface parameters are changed or the printer is reset.</p> <p>Displays only during the printer power-on cycle to indicate the connection to an external print server (also called an external network adapter or ENA) is lost.</p> <p>The serial port is configured to receive fax data, but the connection to the external modem has been lost. If the Fax Port menu item in the FAX MENU is <i>not</i> set to Disabled, the printer automatically assumes a modem is connected for fax processing. See "Fax Menu" on page 102 for more information.</p> <p>Check the interface to:</p> <ul style="list-style-type: none"> • Verify you are using the correct cable. • Make sure the serial interface parameters (protocol, baud, parity, data bits) are correct. <p>If one of these messages display:</p> <ul style="list-style-type: none"> • Press Go to clear the message and continue printing the job. However, some data may not print or may not print correctly. • Reset the printer. Press Menu> or <Menu. The JOB MENU displays. Press Menu> or <Menu until Reset Printer appears on the second line of the operator panel display. Press Select. <p>A network port is installed, but the software cannot establish communications with the port.</p> <ul style="list-style-type: none"> • Press Go to clear the message. The printer disables communications with the network. <p>Note: Resetting the printer deletes all current data from the print buffer, including all Print and Hold jobs. See Reset Printer on page 70 for more information.</p>

Attendance Message	Meaning and Required Action
55 Insufficient Fax Buffer	<p>The printer link buffer used to process data is too full to receive an incoming fax. This message usually displays when the printer is busy receiving, processing, or printing data from a host interface connection while fax data is being received through a serial interface port configured for fax processing.</p> <ul style="list-style-type: none"> • Press Go to clear the message and continue printing the job. However, some data may not print or may not print correctly. • Reset the printer. Press Menu> or <Menu. The JOB MENU displays. Press Menu> or <Menu until Reset Printer appears on the second line of the operator panel display. Press Select. <p>Note: Resetting the printer deletes all current data from the print buffer, including all Print and Hold jobs. See Reset Printer on page 70 for more information.</p> <p>After this message displays, the connection between the printer and the sending fax machine is broken. The printer will not accept additional fax data until sufficient fax buffer space is made available. However, any fax data stored in the fax buffer is printed. See "Fax Menu" on page 102 for more information.</p>
56 Serial Port 1 Disabled	<p>Data is sent to the printer across the serial port, but the serial port is disabled. When the serial error displays, the reporting of other serial errors is suppressed until the menus are entered or the printer is reset.</p> <p>If this message displays:</p> <ul style="list-style-type: none"> • Make sure the Serial Buffer menu item in the SERIAL MENU is <i>not</i> set to Disabled. • Press Go to clear the message. The printer discards any data received on the serial port. • Reset the printer. Press Menu> or <Menu. The JOB MENU displays. Press Menu> or <Menu until Reset Printer appears on the second line of the operator panel display. Press Select. <p>Note: Resetting the printer deletes all current data from the print buffer, including all Print and Hold jobs. See Reset Printer on page 70 for more information.</p>
56 Std Parallel Port Disabled 56 Parallel Port 1 Disabled	<p>Data is sent to the printer through the parallel port, but the parallel port is disabled. When the error displays, the reporting of other errors is suppressed until the menus are entered or the printer is reset.</p> <p>If one of these messages displays:</p> <ul style="list-style-type: none"> • Make sure the Parallel Buffer menu item in the PARALLEL MENU is <i>not</i> set to Disabled. • Press Go to clear the message. The printer discards any data received through the parallel port. • Reset the printer. Press Menu> or <Menu. The JOB MENU displays. Press Menu> or <Menu until Reset Printer appears on the second line of the operator panel display. Press Select. <p>Note: Resetting the printer deletes all current data from the print buffer, including all Print and Hold jobs. See Reset Printer on page 70 for more information.</p>

Attendance Message	Meaning and Required Action
58 Too Many Flash Options	<p>The printer detects more than one flash option installed. Your printer can only have one flash option installed.</p> <ul style="list-style-type: none"> • Press Go to clear the error. • Turn the printer power Off (O). Remove the extra option. Turn the printer power On (I). See "Removing Memory Options" on page 210 for more information.
61 Defective Disk	<p>The printer detects a defective hard disk option. This message appears when you power On (I) the printer, or during hard disk format or write operations.</p> <p>Press Go to clear the message and continue printing. You must install a different hard disk option before you can perform any hard disk operations.</p>
62 Disk Full	<p>There is not enough free space in the hard disk option to store the data that was sent.</p> <ul style="list-style-type: none"> • Press Go to clear the message and continue processing. Any information not previously stored in the hard disk option is deleted. • Reset the printer. Press Menu> or <Menu. The JOB MENU displays. Press Menu> or <Menu until Reset Printer appears on the second line of the operator panel display. Press Select. <p>Note: Resetting the printer deletes all current data from the print buffer, including all Print and Hold jobs. See Reset Printer on page 70 for more information.</p>
63 Unformatted Disk	<p>The printer detects an unformatted hard disk option. This message appears when you power On (I) the printer.</p> <p>You must format the hard disk option before you can perform any hard disk operations. To format the hard disk option, select Format Disk from the UTILITIES MENU.</p> <p>Press Go to clear the message and continue printing. If the error message remains, the hard disk option may be defective and need replacing. Hard disk operations are not allowed until the defective disk is replaced and the new one is formatted.</p>
70 - 79 messages	<p>Reserved for messages relating to the optional internal print server.</p> <p>For more information, refer to the online documentation that comes with your printer. Also, refer to the documentation that comes with the optional internal print server.</p>
200 Paper Jam Remove Cartridge	<p>The printer detects a paper jam. Open the upper front door, remove the print cartridge, and gently remove the jammed print material. Reinstall the print cartridge and close the upper front door. See "200 and 201 Paper Jam - Remove Cartridge" on page 184 for more information.</p> <p>Press Go to clear the message and continue printing. The printer prints a new copy of the page that jammed if Jam Recovery is set to On or Auto. However, the Auto setting does not guarantee the page will print.</p>
201 Paper Jam Remove Cartridge	<p>The printer detects a paper jam. Open the upper front door, remove the print cartridge, and gently remove the jammed print material. Reinstall the print cartridge and close the upper front door. See "200 and 201 Paper Jam - Remove Cartridge" on page 184 for more information.</p> <p>Press Go to clear the message and continue printing. The printer prints a new copy of the page that jammed if Jam Recovery is set to On or Auto. However, the Auto setting does not guarantee the page will print.</p>

Attendance Message	Meaning and Required Action
202 Paper Jam Open Rear Door	<p>The printer detects a paper jam behind the rear output bin door. Open the rear output bin door and gently remove the jammed print material. Close the rear output bin door. See “202 Paper Jam - Open Rear Door” on page 186 for more information.</p> <p>Press Go to clear the message and continue printing. The printer prints a new copy of the page that jammed if Jam Recovery is set to On or Auto. However, the Auto setting does not guarantee the page will print.</p> <p>Once the print job is complete, close the rear output bin door.</p>
203 Paper Jam Short Paper	<p>The printer detects a paper jam behind the rear output bin door. Open the rear output bin door and gently remove the jammed print material. Leave the rear output bin door open. Set PAPER LENGTH to Short from the operator panel. See “203 Paper Jam - Short Paper” on page 190 for more information.</p> <p>Press Go to clear the message and continue printing. The printer prints a new copy of the page that jammed if Jam Recovery is set to On or Auto. However, the Auto setting does not guarantee the page will print.</p> <p>Once the print job is complete, close the rear output bin door.</p>
250 Paper Jam Check MP Feeder	<p>The printer detects a paper jam in the multipurpose feeder. If the print material is visible from the front of the multipurpose feeder, pull it out gently. If only a small portion is visible, open the upper front door, remove the print cartridge, and remove the jammed print material. Reinstall the cartridge and close the upper front door. See “250 Paper Jam - Check MP Feeder” on page 192 for more information.</p> <p>Press Go to clear the message and continue printing. The printer prints a new copy of the page that jammed if Jam Recovery is set to On or Auto. However, the Auto setting does not guarantee the page will print.</p>
900-999 service messages	<p>These service messages indicate printer failures that may require service.</p> <p>When a service message occurs, the printer immediately stops printing. Turn the printer power Off (O), wait for about 10 seconds, and then turn the printer power On (I).</p> <p>If the service message recurs, call for service and report the message number and description of the problem.</p>

Attendance Message	Meaning and Required Action
<p>Change <input source> <Custom Type Name> <size> <type><size></p>	<p>The printer requests a different print material than what is loaded in the tray or set in the PAPER SIZE or PAPER TYPE menus.</p> <p>Line 1 displays the input source (<input source>), which is one of the following items:</p> <ul style="list-style-type: none"> • Tray 1 • Tray 2 • MP Feeder <p>Note: Tray 2 only displays if the optional 500-sheet drawer is installed.</p> <p>Line 2 displays one of the following items:</p> <ul style="list-style-type: none"> • <Custom Type Name>: A user-defined name for Custom Type 1 through 6. The name is truncated to fit on the operator panel display. Use the MarkVision utility to create Custom Type names. See “Introducing MarkVision” on page 25 for more information. • <size>: If the requested type matches the type currently in the paper source and the custom type name has not been defined by you, only the print material or envelope size (<size>) displays. The name is truncated to fit on the operator panel display. • <type><size>: The requested type (<type>) is a type other than a custom type. The requested size (<size>) of print material or envelope displays. The type and size names are truncated to fit on the operator panel display. <p>If you are using Tray 1 or Tray 2 when this message displays, you can:</p> <ul style="list-style-type: none"> • Load the requested size and type print material in the input source. Press Go to continue printing. • Press Select to clear the message and continue printing on the print material installed in the input source. • Cancel the current job. Press Menu> or <Menu. The JOB MENU displays. Press Menu> or <Menu until Cancel Job appears on the second line of the operator panel display. Press Select. • Reset the printer. Press Menu> or <Menu. The JOB MENU displays. Press Menu> or <Menu until Reset Printer appears on the second line of the operator panel display. Press Select. <p>If you are using the multipurpose feeder when this message displays, you can:</p> <ul style="list-style-type: none"> • Load the requested size and type print material in the multipurpose feeder. The printer will clear the message and automatically continue printing. • If the correct print material is already loaded in the multipurpose feeder, press Go. • Cancel the current job. Press Menu> or <Menu. The JOB MENU displays. Press Menu> or <Menu until Cancel Job appears on the second line of the operator panel display. Press Select. • Reset the printer. Press Menu> or <Menu. The JOB MENU displays. Press Menu> or <Menu until Reset Printer appears on the second line of the operator panel display. Press Select. <p>Note: Resetting the printer deletes all current data from the print buffer, including all Print and Hold jobs. See Reset Printer on page 70 for more information.</p>

Attendance Message	Meaning and Required Action
Check Tray 2 Connection	<p>The printer has lost communication with the optional 500-sheet drawer.</p> <p>Communication may be lost if the optional 500-sheet drawer was removed from the printer, for example, to clear a paper jam. The optional 500-sheet drawer may still be attached to the printer, but may not be fully connected or may be experiencing a hardware failure.</p> <p>Note: This message only displays if the optional 500-sheet drawer is installed.</p> <p>If this message displays:</p> <ul style="list-style-type: none"> • Reestablish communication by removing the optional 500-sheet drawer and reattaching it to the printer. See “Installing the Optional Drawer” on page 223 for more information. When the optional 500-sheet drawer is recognized by the printer, the message clears. • In case of a hardware failure, turn the printer power Off (O) and back On (I). If the error recurs, turn the printer power Off (O), remove the optional 500-sheet drawer, and call for service.
Close Door or Insert Cartridge	<p>The upper front door is open or the print cartridge is not installed.</p> <p>Close the door or install the print cartridge, then close the door.</p>
Delete All Jobs. Go/Stop?	<p>The printer requests confirmation to delete all Print and Hold jobs. This message displays if Delete All Jobs is selected from the CONFIDENTIAL JOB menu item or from the HELD JOBS menu item.</p> <ul style="list-style-type: none"> • Press Go to continue. The printer deletes all Print and Hold jobs. • Press Stop to cancel this operation. <p>See CONFIDENTIAL JOB on page 60 or HELD JOBS on page 65 for more information.</p>
Enter PIN: =____	<p>The printer requests you enter a four-digit Personal Identification Number (PIN) associated with your Confidential Job once you enter the CONFIDENTIAL JOB menu item on the operator panel. You use the operator panel buttons to enter the number.</p> <p>See “Entering a Personal Identification Number (PIN)” on page 111 for more information.</p>
Files will be Lost. Go/Stop?	<p>This message displays when you change the Job Buffer Size setting on the operator panel. The printer must reformat the hard disk option. The message asks for confirmation to continue and erase all files on the hard disk option.</p> <ul style="list-style-type: none"> • Press Go to continue. The hard disk option formats and the specified job buffer partition is created. The message Format Disk displays while the hard disk option formats. • Press Stop to cancel this operation.

Attendance Message	Meaning and Required Action
<p>Insert Tray 1</p>	<p>This message displays when the printer needs to select print material from Tray 1 (250-sheet input tray). The printer is requesting the 250-sheet input tray be inserted so it can continue printing. This may happen if you remove the 250-sheet input tray to fill it with print material while a job is printing.</p> <p>Note: This message only displays for Tray 1 if the optional 500-sheet drawer is installed. If the optional 500-sheet drawer is not installed and Tray 1 is removed from the printer after a job is sent to print, a Load <input source> message displays instead. See Load <input source> on page 170 for more information.</p> <p>To avoid this message, press Stop, wait for the job to stop printing, and then remove the 250-sheet input tray to fill it.</p> <p>When this message occurs:</p> <ul style="list-style-type: none"> • Insert Tray 1 to clear the message and continue printing the job. • Cancel the current job. Press Menu> or <Menu. The JOB MENU displays. Press Menu> or <Menu until Cancel Job appears on the second line of the operator panel display. Press Select. • Reset the printer. Press Menu> or <Menu. The JOB MENU displays. Press Menu> or <Menu until Reset Printer appears on the second line of the operator panel display. Press Select. <p>Note: Resetting the printer deletes all current data from the print buffer, including all Print and Hold jobs. See Reset Printer on page 70 for more information.</p>
<p>Install Tray 2 or Cancel Job</p>	<p>The printer has lost communication with the optional 500-sheet drawer support unit. The support unit is not properly attached to the printer when you have sent a job to print.</p> <p>When this message occurs:</p> <ul style="list-style-type: none"> • Reattach the printer to the optional 500-sheet drawer support unit to clear the message and continue printing the job. <ol style="list-style-type: none"> 1 Lift the printer by the handholds or ask someone to help you lift the printer. Make sure your fingers are not under the printer when you set it down. 2 Place the printer on top of the support unit. Make sure the edges of the printer and the support unit are aligned properly. • Cancel the current job. Press Menu> or <Menu. The JOB MENU displays. Press Menu> or <Menu until Cancel Job appears on the second line of the operator panel display. Press Select. • Reset the printer. Press Menu> or <Menu. The JOB MENU displays. Press Menu> or <Menu until Reset Printer appears on the second line of the operator panel display. Press Select. <p>Note: Resetting the printer deletes all current data from the print buffer, including all Print and Hold jobs. See Reset Printer on page 70 for more information.</p>

Attendance Message	Meaning and Required Action
<p>Load <input source> <Custom Type Name> <size> <type><size></p>	<p>The printer is trying to feed print material from an input source it detects is empty. Line 1 displays the input source (<input source>), which is one of the following items:</p> <ul style="list-style-type: none"> • Tray 1 • Tray 2 • MP Feeder <p>Note: Tray 2 only displays if the optional 500-sheet drawer is installed.</p> <p>Line 2 displays one of the following items:</p> <ul style="list-style-type: none"> • <Custom Type Name>: A user-defined name for custom type 1 through 6. The name is truncated to fit on the operator panel display. Use the MarkVision utility to create custom type names. See "Introducing MarkVision" on page 25 for more information. • <size>: If the requested type matches the type currently in the tray and the custom type name has not been defined by you, only the print material or envelope size displays. The name is truncated to fit on the operator panel display. • <type><size>: The requested type (<type>) is a type other than a custom type. The requested size <size> of print material or envelope displays. The type and size names are truncated to fit on the operator panel display. <p>If you are using Tray 1 or Tray 2 when this message displays, you can:</p> <ul style="list-style-type: none"> • Load the requested size and type print material in the input source. Press Go to continue printing. • Cancel the current job. Press Menu> or <Menu. The JOB MENU displays. Press Menu> or <Menu until Cancel Job appears on the second line of the operator panel display. Press Select. • Reset the printer. Press Menu> or <Menu. The JOB MENU displays. Press Menu> or <Menu until Reset Printer appears on the second line of the operator panel display. Press Select. <p>If you are using the multipurpose feeder when this message displays, you can:</p> <ul style="list-style-type: none"> • Load the requested size and type print material in the multipurpose feeder. The printer will clear the message and automatically continue printing. • If the correct print material is already loaded in the multipurpose feeder, press Go. • Cancel the current job. Press Menu> or <Menu. The JOB MENU displays. Press Menu> or <Menu until Cancel Job appears on the second line of the operator panel display. Press Select. • Reset the printer. Press Menu> or <Menu. The JOB MENU displays. Press Menu> or <Menu until Reset Printer appears on the second line of the operator panel display. Press Select. <p>Note: Resetting the printer deletes all current data from the print buffer, including all Print and Hold jobs. See Reset Printer on page 70 for more information.</p>

Attendance Message	Meaning and Required Action
<p>Load Manual <Custom Type Name> <size> <type><size></p>	<p>The printer requests print material to be manually fed from the multipurpose feeder. Line 2 displays one of the following items:</p> <ul style="list-style-type: none"> • <Custom Type Name>: A user-defined name for custom type 1 through 6. The name is truncated to fit on the operator panel display. Use the MarkVision utility to create custom type names. See "Introducing MarkVision" on page 25 for more information. • <size>: If the requested type matches the type currently in the tray and the custom type name has not been defined by you, only the print material or envelope size displays. The name is truncated to fit on the operator panel display. • <type><size>: The requested type (<type>) is a type other than a custom type. The requested size (<size>) of print material or envelope displays. The type and size names are truncated to fit on the operator panel display. <p>When this message displays you can:</p> <ul style="list-style-type: none"> • Load the requested size or type of print material in the multipurpose feeder. The printer automatically clears the message and continues printing. • Press Go if the correct size and type print material is loaded in the multipurpose feeder. • Press Select to clear the message and print on the print material installed in Tray 1 or the optional Tray 2. • Cancel the current job. Press Menu> or <Menu. The JOB MENU displays. Press Menu> or <Menu until Cancel Job appears on the second line of the operator panel display. Press Select. • Reset the printer. Press Menu> or <Menu. The JOB MENU displays. Press Menu> or <Menu until Reset Printer appears on the second line of the operator panel display. Press Select. <p>Note: Resetting the printer deletes all current data from the print buffer, including all Print and Hold jobs. See Reset Printer on page 70 for more information.</p>
<p>No Jobs Found. Retry?</p>	<p>The Personal Identification Number (PIN) you entered is not a PIN associated with any Confidential Job in printer memory.</p> <ul style="list-style-type: none"> • Press Go to enter another PIN. • Press Stop to exit the PIN entry prompt. <p>See "Entering a Personal Identification Number (PIN)" on page 111 for more information.</p>

Attendance Message	Meaning and Required Action
Open Rear Door	<p>The print material in the multipurpose feeder is 152.4 mm (6 in.) or less in length and the rear output bin door is not open.</p> <p>When this message displays you can:</p> <ul style="list-style-type: none"> • Open the rear output bin door to let the print material exit. • Cancel the current job. Press Menu> or <Menu. The JOB MENU displays. Press Menu> or <Menu until Cancel Job appears on the second line of the operator panel display. Press Select. • Reset the printer. Press Menu> or <Menu. The JOB MENU displays. Press Menu> or <Menu until Reset Printer appears on the second line of the operator panel display. Press Select. <p>Note: Resetting the printer deletes all current data from the print buffer, including all Print and Hold jobs. See Reset Printer on page 70 for more information.</p>
Operation Failed Jobs on Disk Operation Failed Faxes on Disk	<p>This message displays when the printer receives a request to format the hard disk option or modify the Job Buffer Size setting and Print and Hold jobs are currently stored on the hard disk option.</p> <p>This message displays when the printer receives a request to format the hard disk option or modify the Job Buffer Size setting and fax jobs are currently stored on the hard disk option.</p> <p>You cannot format the hard disk option or change the Job Buffer Size while the hard disk option contains Print and Hold jobs or fax jobs.</p> <ul style="list-style-type: none"> • Press Go to continue. The request is ignored.
Print Jobs on Disk? Go/Stop?	<p>This message displays when Print Job Buffering is enabled and the printer power is turned Off (O) while print jobs are spooled to the hard disk option. When the printer power is turned back On (I), it asks for confirmation to print the waiting jobs.</p> <ul style="list-style-type: none"> • Press Go to print the jobs. • Press Return or Stop to delete all spooled jobs from the hard disk option without printing them.

7

Solving Printer Problems

Sometimes printer problems are very easy to solve. When you have a problem, first make sure that:

Note: If an error message displays, see “Understanding Printer Messages” on page 151.

- The printer power cord is plugged into the printer and a properly grounded electrical outlet.
- The printer power switch is On (|).
- The electrical outlet is not turned off by any switch or breaker.
- Other electrical equipment plugged into the outlet is working.
- All options are properly installed.

If you have checked all of the above and still have a problem, turn the printer power Off (O), wait for about 10 seconds, and then turn the printer power On (|). This often fixes the problem.

The tables in this chapter define printing problems that may occur and what you can do to resolve them. If the suggested corrective action does not fix the problem, call your service representative.

Turn to the appropriate page for help with your printing problem:

Problem with...	See page...
Display	175
Print Quality	178
Printing	176
Network	181
Option	180
Other Problems and Questions	182

Display Problems

Problem	Action
<p>Menus Disabled status message appears on the display.</p>	<p>The operator panel menus are disabled. To enable the menus:</p> <ul style="list-style-type: none"> • Turn the printer power Off (O). • Press and hold Select and Return, and then turn the printer power On (I). • Release the buttons when Performing Self Test displays. <p>Once the printer finishes powering on, the CONFIG MENU displays.</p> <ul style="list-style-type: none"> • Press Menu> until Panel Menu displays on the second line. Press Select. • Press Menu> until Enable displays on the second line. Press Select. <p>The Saved message briefly appears and then, the Enabling Menus displays. The CONFIG MENU displays again with Panel Menu on the second line.</p> <ul style="list-style-type: none"> • Press Menu> until Exit Config Menu displays on the second line. Press Select. <p>Activating Menu Changes briefly appears, and then Performing Self Test briefly appears. The printer returns to the Ready state.</p> <p>If the operator panel menus are password protected, see your system administrator.</p>
<p>Display shows only diamonds or is blank.</p>	<ul style="list-style-type: none"> • Turn the printer power Off (O), wait about 10 seconds, and turn the printer power On (I). • The Performing Self Test message appears on the operator panel display. When the test is completed, the Ready message displays. <p>If the messages do not display, turn the printer power Off (O) and call Lexmark Customer Support Center.</p>
<p>Menu settings changed from the operator panel have no effect.</p>	<p>Settings in the software application, the printer driver, or the printer utilities are overriding the settings in the operator panel.</p> <ul style="list-style-type: none"> • Change the menu settings from the printer driver, the printer utilities, or the software application instead of the operator panel. • Disable the settings in the printer driver, the printer utilities, or the software application so you can change settings from the operator panel.

Printing Problems

Problem	Action
Job did not print or incorrect characters printed.	Make sure the Ready status message appears on the operator panel display before you send a job to print. Press Go to return the printer to the Ready status message.
	Make sure there is print material loaded in the printer. Press Go to return the printer to the Ready status message.
	Verify that the printer is using the correct printer language.
	<ul style="list-style-type: none"> • Verify that the correct printer driver is being used. • Make sure the parallel cable or USB cable is firmly plugged in at the back of the printer. • Check the cable connection. Make sure you are using the correct cable. If you use the parallel port, we recommend a IEEE 1284-compliant parallel cable such as Lexmark part number 1329605 (10 ft) or 1427498 (20 ft). If you use the USB port, we recommend the cable with Lexmark part number 12A2405 (2M). • If the printer is connected through a switch box, try a direct connection. • Verify that the correct paper size is selected through the operator panel, in the printer driver, or in the software application setting. • Make sure PCL SmartSwitch and PS SmartSwitch are set to On. • If a print spooler is used, verify that the spooler is not stalled. • If you print across a network or on a Macintosh, see “Network Printing Problems” on page 181.
	<p>Determine which host interface you are using. Print a menu settings page to verify that the current interface settings are correct. See “Printing the Menu Settings Page” on page 39 for more information.</p> <p>If you are using serial interface:</p> <ul style="list-style-type: none"> • Make sure Honor DSR is set to Off. • Check the protocol, baud, parity, and data bit settings. The settings on the printer and on the host computer should match.
You are connected to the USB port, but the printer will not print.	Make sure you are using Windows 98 or other USB-capable operating system supported by Lexmark.

Problem (continued)	Action (continued)
Print material misfeeds or multiple feeds occur.	<ul style="list-style-type: none"> • Make sure the print material you are using meets the specifications for your printer. See “Print Material Guidelines” on page 118 for more information. • Flex print material before loading it in any of the paper sources. • Make sure the print material is loaded correctly. • Make sure the paper width and length guides on the paper sources are adjusted correctly and are not too tight. • Do not overfill the paper sources. • Do not force print material into the multipurpose feeder when you load it; otherwise, it may skew or buckle. • Remove any curled print material from paper sources. • If there is a recommended print side for the print material, load the print material as described in “Print Material Guidelines” on page 118. • Load less print material in the input sources. • Turn the print material over or around and try printing again to see if feeding improves. • Do not mix print material types. • Do not mix reams of print material. • Remove the top and bottom sheets of a ream before loading the print material. • Load an input source only when it is empty.
You get unexpected page breaks.	Check the Print Timeout setting in the SETUP MENU . Increase the setting. See Print Timeout on page 74 for more information.
Job prints from the wrong input source or on the wrong print material.	Check the PAPER TYPE setting in the PAPER MENU on the operator panel and in the printer driver. See PAPER TYPE on page 47 for more information.
Print material does not stack neatly in an output bin.	<ul style="list-style-type: none"> • Turn the print material stack over in the tray or multipurpose feeder. • If the print material is exiting to the standard output bin, make sure the paper bail is installed correctly. See “Installing the Paper Bail” on page 11 for more information.

Print Quality Problems

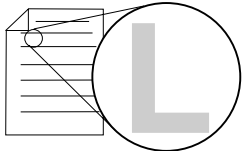
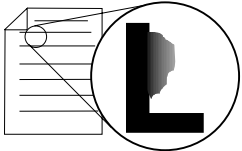
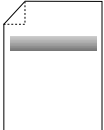
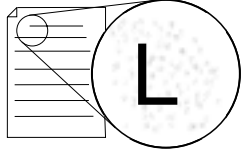
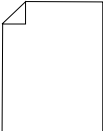
Problem	Action
<p>Print is too light.</p> 	<ul style="list-style-type: none"> • Check the toner supply. • Change the Toner Darkness setting in the QUALITY MENU. See Toner Darkness on page 71 for more information. • If you are printing on an uneven print surface, change the PAPER WEIGHT and PAPER TEXTURE settings in the PAPER MENU. See PAPER TYPE on page 47 for more information. • Verify that the correct print material is being used.
<p>Toner smears or print comes off the page.</p> 	<ul style="list-style-type: none"> • If you are printing on an uneven print surface, change the PAPER TEXTURE and PAPER WEIGHT settings in the PAPER MENU. See PAPER TEXTURE on page 50 and PAPER WEIGHT on page 51 for more information. • Verify that the print material is within the printer specifications. See “Using Print Materials” on page 115 for more information. • If the problem continues, call Lexmark Customer Support Center.
<p>Toner appears on the back of the printed page.</p> 	<p>Toner is on the transfer roll. To help prevent this, do not load print material that is smaller than the page size of the job to be printed.</p> <ul style="list-style-type: none"> • Open and close the printer upper front door to run the printer through its setup cycle and clean the transfer roll. • Replace the fuser cleaner. The fuser cleaner and replacement instructions are included in the box when you purchase a new print cartridge.
<p>Toner fog or background shading appears on the page.</p> 	<ul style="list-style-type: none"> • Check the print cartridge to make sure it is installed correctly. See “Installing the Print Cartridge” on page 5 for more information. • Change the print cartridge. See “Maintaining Your Printer” on page 193 for more information. • If the problem continues, change the charge roll. See “Ordering a Charge Roll Kit” on page 195 for more information.
<p>Entire page is white.</p> 	<ul style="list-style-type: none"> • Make sure the packaging material is removed from the print cartridge. See “Removing Print Cartridge Packaging” on page 2. • Check the print cartridge to be sure it is installed correctly. See “Installing the Print Cartridge” on page 5 for more information. • Check the toner supply.

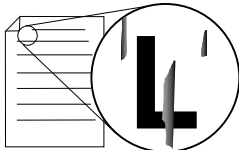
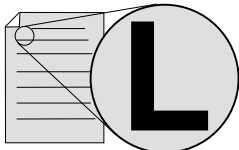
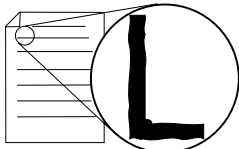
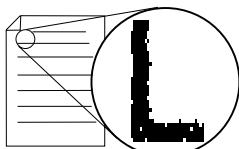
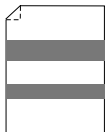
Problem (continued)	Action (continued)
<p>Streaks appear on the page.</p> 	<ul style="list-style-type: none"> • The toner may be low. Remove the cartridge. To utilize the remaining toner, shake the cartridge gently. Reinstall the same print cartridge. See “Installing the Print Cartridge” on page 5 for directions. • If you are using preprinted forms, make sure the ink can withstand temperatures of 200°C (392°F). • The printhead lens may need cleaning. See “Cleaning the Printhead Lens” on page 195 for directions.
<p>Printing is too dark.</p> 	<p>Change the Toner Darkness setting in the QUALITY MENU. See Toner Darkness on page 71 for more information.</p> <p>Note: Macintosh users should make sure the lines per inch (lpi) setting is not set too high in the software application.</p>
<p>Characters have jagged or uneven edges.</p> 	<ul style="list-style-type: none"> • Change the Print Resolution setting in the QUALITY MENU to 600 dpi. See Print Resolution on page 71 for more information. • Turn PQET in the QUALITY MENU to On. See PQET on page 72 for more information. • If you are using downloaded fonts, verify that the fonts are supported by the printer, the host computer, and the software application.
<p>Image quality is poor.</p> 	<p>Resolution was automatically reduced. Reduce the complexity of the print job or add additional printer memory. See Res Reduced on page 157 for more information.</p>
<p>Part of all of the page is printed in black.</p> 	<ul style="list-style-type: none"> • Check the print cartridge to see if it is installed correctly. See “Installing the Print Cartridge” on page 5 for more information. • If the charge roll has been replaced, verify that it has been installed correctly. Refer to the installation instructions that come with the charge roll kit. See “Ordering a Charge Roll Kit” on page 195 for more information.
<p>The job prints, but the left and top margins are incorrect.</p>	<ul style="list-style-type: none"> • Make sure the PAPER SIZE setting is set correctly in the PAPER MENU. See PAPER SIZE on page 45 for more information. • Make sure the margins are set correctly in the software application you are using. • Check the Print Area setting in the SETUP MENU. Set the value to Normal. See Print Area on page 76 for more information.

Option Problems

Problem	Action
Option does not operate correctly after it is installed or it quits working.	<ul style="list-style-type: none"> • Turn the printer power Off (O), wait for about 10 seconds, and turn the printer power On (I). If this does not fix the problem, unplug the printer, and check the connection between the option and printer. • Print the menu settings page and check to see if the option is listed in the Installed Options list. If the option is not listed, reinstall it. See “Verifying the Installation of Options” on page 229 for more information. • Make sure the option is selected in the software application you are using. <p>For Macintosh users: Make sure the printer is set up in CHOOSER.</p>
Option does not operate correctly after it is installed.	<p>Optional Drawer: Make sure the connection between the optional 500-sheet drawer and the printer is secure. See “Optional 500-Sheet Drawer” on page 223 for more information.</p> <p>Make sure the print material is loaded correctly. See “Loading Print Material” on page 124 for more information.</p>
	<p>Flash Memory Option: Check to make sure the flash memory option is securely connected to the printer system board. See “Understanding Memory Options” on page 206 for more information.</p>
	<p>Printer Memory Option: Check to make sure the printer memory option is securely connected to the printer system board. See “Understanding Memory Options” on page 206 for more information.</p>
	<p>Hard Disk Option: Check to make sure the hard disk option is securely connected to the printer system board. See “Hard Disk Option” on page 212 for more information.</p>
	<p>Hard Disk Adapter Card: Check to make sure the hard disk option is securely connected to the hard disk adapter card. Also check to make sure the hard disk adapter card is securely connected to the printer system board. See “Hard Disk Option” on page 212 for more information.</p>
	<p>Internal Print Server Option: Check to make sure the optional internal print server (also called an internal network adapter or INA) is securely connected to the printer system board. See “Internal Print Server (Internal Network Adapter or INA)” on page 211 for more information.</p> <p>The connection to the network is made through the network cable. Check that you have the correct cable, that it is securely connected, and that the network software is correctly set up. See the documentation that comes with your optional internal print server for more information.</p>
	<p>Tri-Port Interface Option: Check to make sure the Tri-Port Interface option card is securely connected to the printer system board. See “Tri-Port Interface Option Card” on page 212 for more information.</p> <p>For Macintosh users: Make sure the host computer is set to LocalTalk.</p> <p>If you are using a phone wire connection, a terminator plug must be used.</p>

Problem (continued)	Action (continued)
Option does not operate correctly after it is installed. (continued)	<p>Infrared Adapter: If infrared communication stops or does not occur, check the following:</p> <ul style="list-style-type: none"> • Communication distance: The distance between the two infrared ports should be 3 meters (10 ft.) or less. If communication does not occur between ports, move the ports closer together. • Make sure both ports are stable. Make sure the computer is on a level surface. • Make sure the angle of communication between the two infrared ports is within 15 degrees of either side of an imaginary line drawn between the two infrared ports. • Make sure there is no bright light, such as direct sunshine, interfering with communication. • Make sure no objects are placed between the two infrared ports. <p>Parallel/USB Interface Option: Check to make sure the parallel/USB interface option card is securely connected to the printer system board. See "Parallel/USB Interface Option Card" on page 215 for more information.</p>

Network Printing Problems

Problem	Action
Job did not print or incorrect characters printed.	<p>If you are using a Lexmark internal print server or external print server, verify that it is set up properly and the network cable is connected.</p> <p>Note: Refer to the documentation that comes with your print server for more information.</p> <p>For Novell users:</p> <ul style="list-style-type: none"> • Make sure the netware.drv file is dated October 24, 1994 or later. • Make sure the NT (no tabs) flag is included in the capture statement. <p>For Macintosh users:</p> <ul style="list-style-type: none"> • The printer may need an optional internal print server to allow Macintosh connection. • Verify that the printer is set up correctly in CHOOSER.

Other Problems and Questions

Problem	Action
How do I get updated printer drivers or utilities?	See "Introducing MarkVision" on page 25 for more information.
How do I attach a serial cable to the printer?	Your printer requires an optional adapter to allow serial attachment. The Tri-Port interface option card supports serial RS-232C/RS-422A. See "Tri-Port Interface Option Card" on page 212 for more information.
Where are the printer escape codes listed?	The CD that was shipped with your printer contains an Adobe Acrobat file with a complete list of Printer Command Language (PCL) escape codes.

8

Clearing Jams

By carefully selecting print materials and loading them properly, you should be able to avoid most paper jams. If paper jams do occur, complete the steps in the following sections. If paper jams occur frequently, make sure you see “Avoiding Paper Jams” on page 137.

To clear paper jam attendance messages, you must remove all jammed print material from the paper path.

Press **Go** to resume printing. If **Jam Recovery** is set to **On** or **Auto**, the printer prints a new copy of the page that jammed. However, the **Auto** setting does not guarantee the page will print.

Refer to the appropriate page for help with clearing paper jams.

If the following error message displays...	See page...
200 Paper Jam - Remove Print Cartridge	184
201 Paper Jam - Remove Print Cartridge	184
202 Paper Jam - Open Rear Door	186
203 Paper Jam - Short Paper	190
250 Paper Jam - Check MP Feeder	192

Possible Paper Jam Areas

The following illustration shows the path that print material travels through the printer. The path varies depending on the input source and exit selection (output bin). The jam areas are also shown.

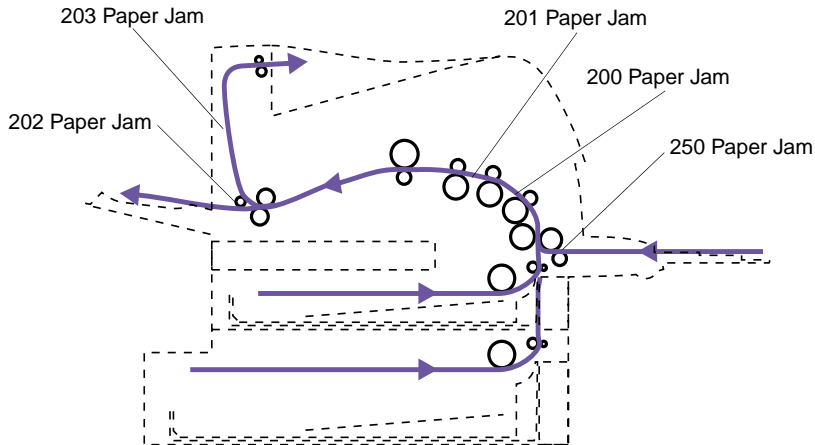

200 and 201 Paper Jam - Remove Cartridge

Print material is jammed in the area under the print cartridge. This requires removing the print cartridge from the printer. With a 201 attendance message, the jam is farther back in the printer, so you need to reach in farther to remove the jammed print material.

Note: To clear paper jam attendance messages, you must remove all jammed print material from the paper path.

- 1 Open the upper front door.**
- 2 Remove the print cartridge.**

See page 2 for instructions on removing the print cartridge.

Caution! The rear portion of the inside of the printer may be hot.

- 3 Notice that in some instances the ends of the print material are not visible.

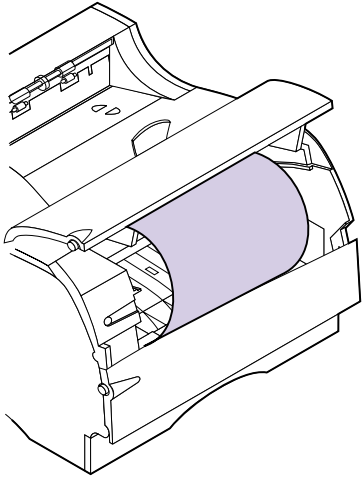

- 4 Gently pull the right side of the print material until the upper right corner is loose.
- 5 With both hands, pull the print material up to the right and then out.
- 6 Reinstall the print cartridge. (See page 5 for instructions on reinstalling the print cartridge.)
- 7 Close the upper front door.

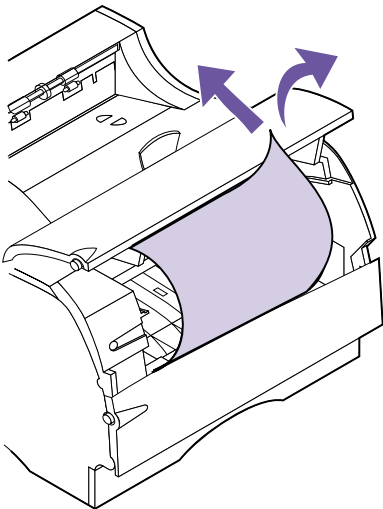

Note: If there is resistance to the print material, and it does not move immediately when you pull it, stop pulling and access the print material from the rear output bin door. See “202 Paper Jam - Open Rear Door” on page 186 for more information.

202 Paper Jam - Open Rear Door

Jams in the following areas cause a 202 attendance message. Jams in these areas require opening the printer rear output bin door and the upper front door:

- The print material jams before reaching the standard output bin. See “Before Reaching the Standard Output Bin” as follows.
- The print material jams after it starts into the standard output bin, but before it exits completely into the bin. See “Exiting to the Standard Output Bin” on page 189.

Note: To clear paper jam attendance messages, you must remove all jammed print material from the paper path.

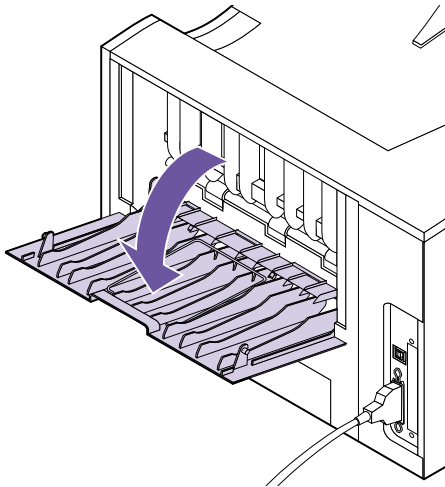

Before Reaching the Standard Output Bin

The print material jams before reaching the standard output bin.

- 1** Locate the handhold on the rear output bin door and pull it toward you.

The rear output bin door opens and drops back toward you. If you need help, see “Using the Rear Output Bin” on page 134.

2 Determine how to remove the jammed print material based on what part of the print material is visible.

- If the middle of the sheet of print material is visible, but not the ends, grasp the print material on both sides and gently pull it straight out toward you.

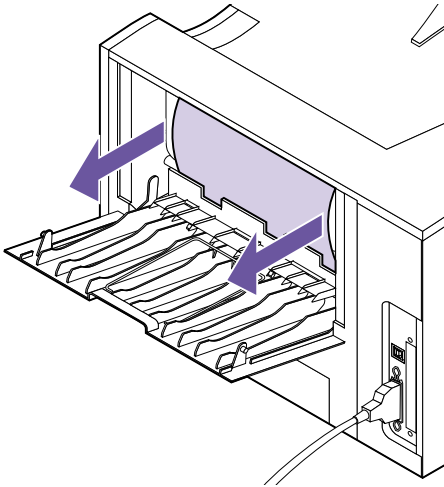

Note: If print material is still in the fuser area, open the upper front door to release the fuser rollers to free the print material.

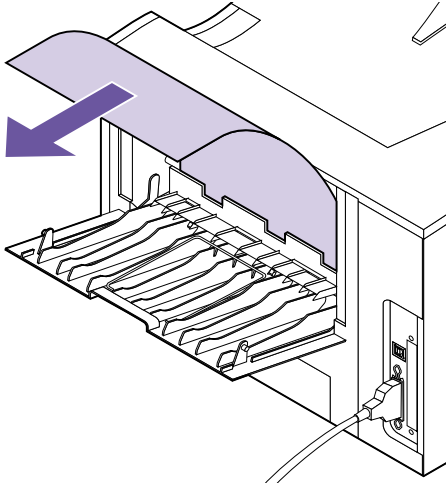

- If an end of the print material is visible, pull the print material straight out toward you.

Note: To avoid tearing, pull the jammed print material out gently and slowly.

3 Close the rear output bin door.

Note: To clear paper jam attendance messages, you must remove all jammed print material from the paper path.

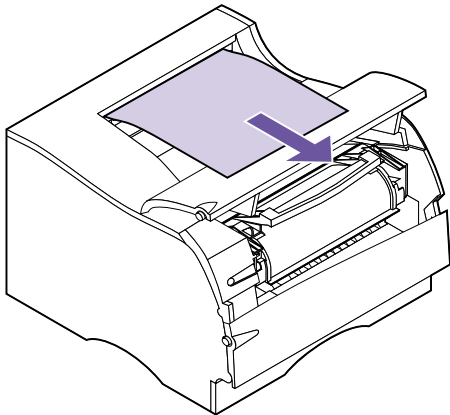
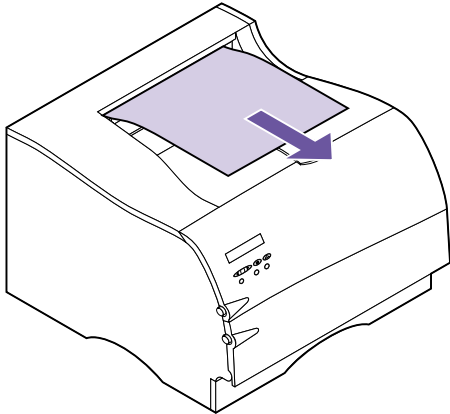

Note: To avoid tearing, pull the jammed print material out gently and slowly.

Exiting to the Standard Output Bin

Print material jams before it exits completely into the standard output bin.

- 1 Pull the print material straight out.** If there is resistance to the print material and it does not move immediately when you pull, stop pulling and continue with the next step.
- 2 Open the upper front door to release the fuser rollers.**
- 3 Pull the print material straight out.**

203 Paper Jam - Short Paper

A 203 attendance message indicates print material less than 152.4 mm (6 in.) in length has attempted to exit the standard output bin.

A jam in this area requires that the rear output bin door be opened.

Note: To clear paper jam attendance messages, you must remove all jammed print material from the paper path.

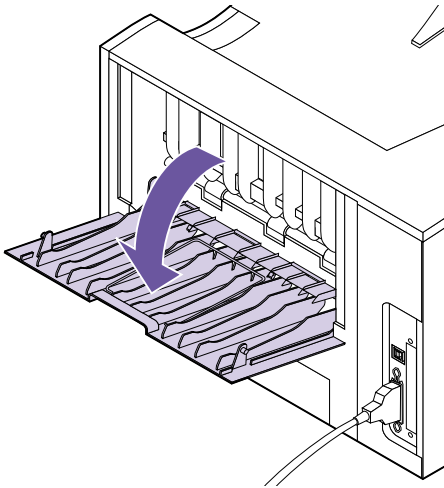

- 1** Locate the handhold on the rear output bin door and pull it toward you.

The rear output bin door opens and drops back toward you. If you need help, see “Using the Rear Output Bin” on page 134.

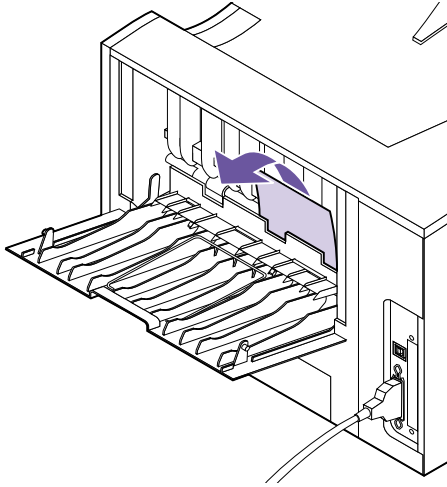

Note: If you cannot find the jammed print material inside the printer, check to see if the print job has exited the standard output bin.

2 Remove the print material.

If there is resistance to the print material and it does not move immediately when you pull, stop pulling. Remove the print cartridge, return to the back of the printer, and pull the print material out.

3 Leave the rear output bin door open to allow the job to finish printing.

4 Press Go to resume printing.

5 If you are going to print additional pages less than 152.4 mm (6 in.) in length, set Paper Length to Short.

250 Paper Jam - Check MP Feeder

The print material jams as it enters the printer from the multipurpose feeder.

Pull the jammed print material straight out of the multipurpose feeder toward you.

To avoid tearing, pull the jammed print material out gently and slowly.

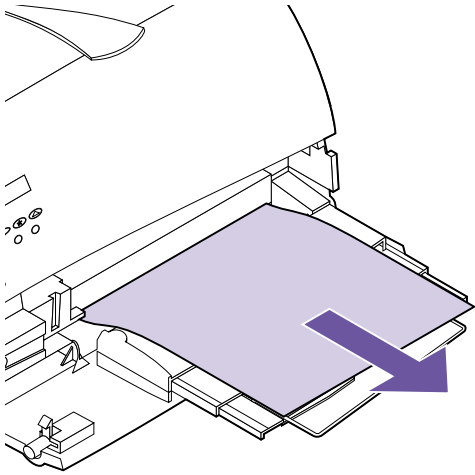

Note: To clear paper jam attendance messages, you must remove all jammed print material from the paper path.

9

Maintaining Your Printer

Note: If you are in the U.S. or Canada, call 1-800-438-2468 for information about Lexmark Authorized Supplies Dealers in your area. In other countries, contact the place where you bought your printer.

Periodically, you will need to replace the print cartridge and clean the printer to maintain optimum print quality.

If several people are using the printer, you may want to designate a key operator to do the setup and maintenance of your printer. Refer printing problems and maintenance tasks to this key operator.

Ordering a Print Cartridge

You need to have a new print cartridge available when the current one no longer prints satisfactorily. There are two recommended print cartridges specifically designed for your printer:

Printer Model	Part Number	Yield (Average)	Coverage
Optra M410 or M412	17G0152	5,000 pages	5%
Optra M410 or M412	17G0154	15,000 pages	5%

Storing the Print Cartridge

Store the print cartridge in the original packaging until you are ready to install it.

Do not store the print cartridge in:

- Temperatures greater than 40°C (104°F).
- An environment with extreme changes in humidity or temperature.
- Direct sunlight.
- Dusty places.
- A car for a long period of time.
- An environment where corrosive gases are present.
- An environment with salty air.

Replacing the Print Cartridge

Warning! Do *not* refill used print cartridges or purchase a refilled cartridge. The print cartridge warranty is voided by unauthorized refilling.

Complete the following steps to replace the print cartridge. Refer to the documentation that comes with the print cartridge for detailed installation information.

- 1 Remove the used print cartridge.**
- 2 Clean the printer.**
- 3 Install the new print cartridge.**
- 4 Replace the fuser cleaner.**

Use the installation instructions that come in the box with your new print cartridge to complete steps 2 through 4.

- 5 Follow the instructions on the new print cartridge box to recycle the used print cartridge.**

When you return a used print cartridge, you contribute to a worldwide recycling effort at no cost to you.

For best results, use Lexmark supplies with the printer.



Cleaning the Printhead Lens

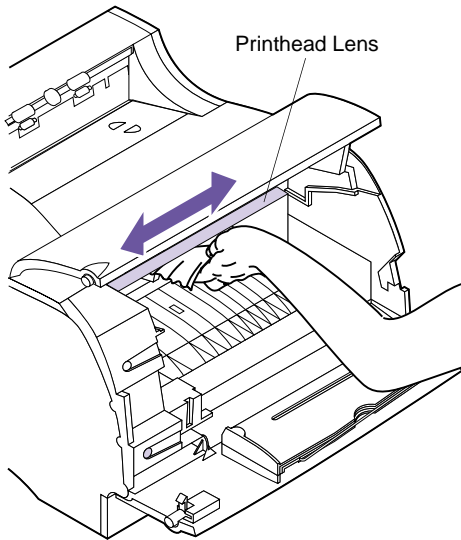

Complete the following steps to clean the printhead lens:

- 1** Turn the printer power Off (O).
- 2** Open the upper and lower front doors.
- 3** Remove the print cartridge.
- 4** Gently wipe the printhead lens with a clean, dry lint-free cloth.
- 5** Insert the print cartridge.
- 6** Close the upper and lower front doors.
- 7** Turn the printer power On (|).

Ordering a Charge Roll Kit

We recommend you order a new charge roll kit when toner fog or background shading appears on printed pages. See "Print Quality Problems" on page 178 for more information on toner fog and background shading.

Order Lexmark part number 4K00196. Installation instructions are included in the kit.

If you're in the U.S. or Canada, call 1-800-438-2468 for information about Lexmark Authorized Supplies Dealers in your area. In other countries, contact the place where you bought your printer.

10

Understanding the Fax Port

If your printer has a Tri-Port interface option card installed and the serial interface port is not in use, you can use your printer to receive and print fax data.

The serial interface port is only available if a Tri-Port interface option card is installed in your printer. See “Tri-Port Interface Option Card” on page 212 for more information.

When you want to use the fax serial port for another purpose, you must first follow the instructions for disabling the fax port on page 200. If you decide to reactivate the fax port, make sure you follow the instructions for setting up the fax port on page 198.

Note: Never attempt to configure your serial port for multiple uses with an A-B switch.

Choosing Hardware

To use your printer serial port to process fax data, you need an external, class 1 fax modem. You can use virtually any brand, as long as it is a class 1 fax modem.

Setting Up a Fax Port

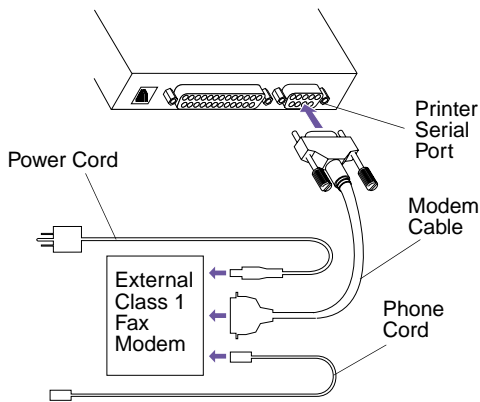

Note: It is very important to power on the modem *before* you power on the printer.

Note: See “Using the Operator Panel and Menus” on page 33 to identify the display and operator panel buttons if you need help.

To use your printer serial port to process fax data:

- 1** Turn the printer power Off (O) and unplug the printer power cord.
- 2** Turn the modem power Off and unplug the modem power cord.
- 3** Disconnect all cables from the back of the printer.
- 4** Connect the hardware. The end of the modem cable that connects to the serial port must be 25-pin.

The class 1 fax modem connects to the serial port of your printer. If you need additional help, refer to the class 1 fax modem documentation for details.

- 5** Reconnect all cables to the back of the printer.
- 6** Reconnect the power cords to the printer and the modem to properly grounded electrical outlets.
- 7** Turn the modem power On.
- 8** Turn the printer power On (|).
- 9** Once Ready displays, complete the following steps to configure the serial port for fax data:

- a** Press Menu> or <Menu to enter the menus.
- b** Press Menu> until FAX MENU appears on the first line of the display.
- c** Press Select.
Fax Port appears on the second line of the display.
- d** Press Select to choose Fax Port.

Note: If an error message appears, see “Understanding Printer Messages” on page 151.

e Press Menu> until Ser Option 1 appears on the second line of the display.

f Press Select to choose Ser Option 1.

g Fax Port appears on the second line. Press Go.

Activating Menu Changes appears and remains on the display until the serial port is reset.

See “Fax Menu” on page 102 for more information.

Resetting a Fax Port

If power to the modem is interrupted you must complete the following steps, *in order*, for your printer to process fax data:

- 1** Turn the printer power Off (O).
- 2** Turn the modem power On.
- 3** Turn the printer power On (|).

Disabling a Fax Port

To disable the fax port and restore the printer serial port settings:

- 1** When Ready displays on the top line of the operator panel display, press Menu> or <Menu to enter the menus.
- 2** Continue to press Menu> or <Menu until FAX MENU appears on the first line of the display.
- 3** Press Select.
Fax Port appears on the second line of the display.
- 4** Press Select to choose Fax Port.
- 5** Press Menu> until Disabled appears on the second line of the display.
Serial Option 1 displays on the second line of the display.
- 6** Press Select to disable the fax port.
- 7** Press Go.
Activating Menu Changes appears and remains on the display until the printer restores the serial port settings.
- 8** Turn the modem power Off.
- 9** Turn the printer power Off (O).
- 10** Disconnect all system components from the modem.
- 11** Disconnect the modem cable from the printer serial port.
- 12** Turn the printer power On (|).

See “Fax Menu” on page 102 for more information.

Note: If an error message appears, see “Understanding Printer Messages” on page 151.

11

Memory and Option Cards

Note: You need a small Philips screwdriver to complete the installation of some options.

You can customize your printer memory capacity and connectivity. This chapter provides instructions for installing and removing each option. To install each option, you must first access the printer system board. This can be done from the left side of the printer.

Accessing the Printer System Board

Complete the following steps before installing printer memory, a flash memory option, or an option card.

Caution! To avoid electrical shock hazards, make sure your computer power is Off (O) and unplug all computer equipment before connecting cables.

- 1 Turn the printer power Off (O) and unplug the printer power cord from the electrical outlet.**
- 2 Disconnect all cables from the back of the printer.**

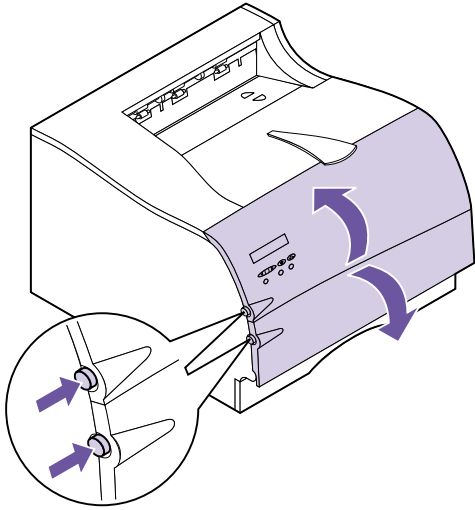

3 Push the upper release latch to release the upper front door.

4 Push the lower release latch to release the lower front door.

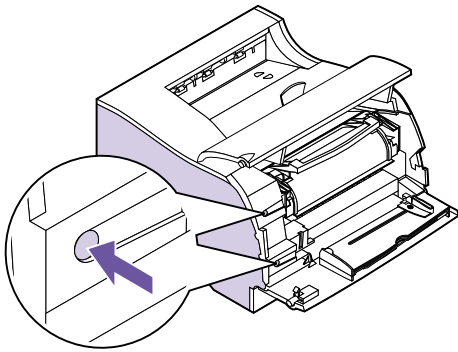

5 Press the latches located inside the front of the printer to release the side door.

6 Remove the side door and lay it aside.

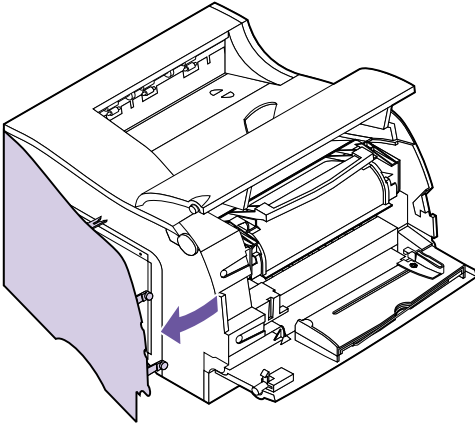

7 Loosen the six screws on the shield. Do not remove the screws.

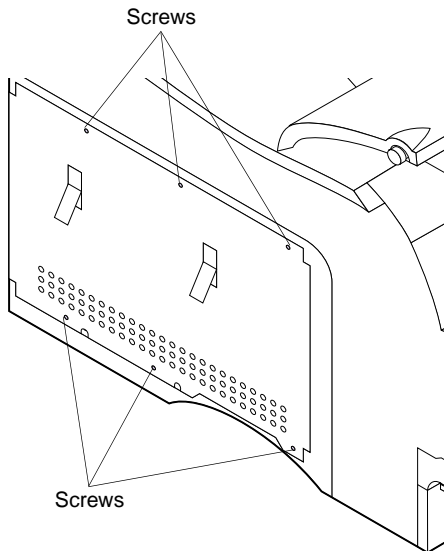

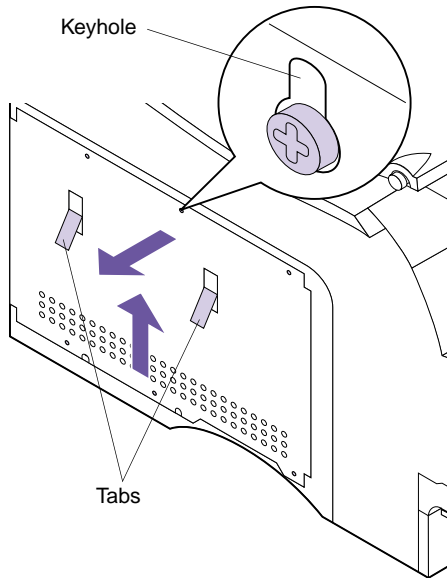

8 Use the tabs located on the side of the shield to slide the shield up until the top three screws fit into the three keyholes on the shield.

9 Hold the shield by the tabs and lift it off.

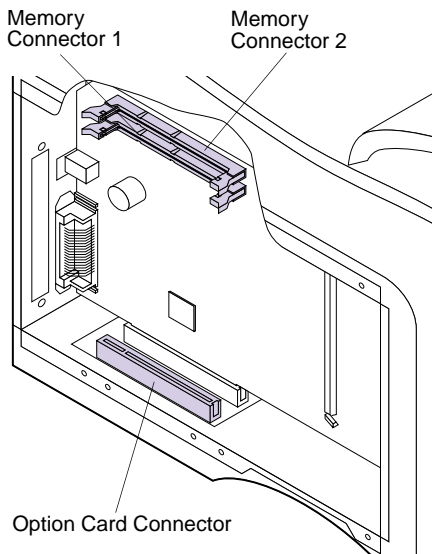

10 Locate the appropriate connector for the option you are installing.

Note: Both memory connector 1 and memory connector 2 are capable of accepting either a printer memory option or a flash memory option card.

11 See the appropriate section for instructions on installing the option.

- For a printer memory or flash memory option, see “Installing Memory Options” on page 207.
- For an optional internal print server (also called an internal network adapter or INA), see “Internal Print Server (Internal Network Adapter or INA)” on page 211.
- For a Tri-Port interface option card, see “Tri-Port Interface Option Card” on page 212.
- For a hard disk option, see “Hard Disk Option” on page 212.
- For a Parallel/USB interface option card, see “Parallel/USB Interface Option Card” on page 215.

Understanding Memory Options

Because the steps required to install a printer memory option and a flash memory option card are the same, they are grouped together in this section. Details about the two option cards follow.

Printer Memory

The printer memory option increases the printer sync dynamic random access memory (SDRAM). Additional printer memory allows the printer to print complex jobs and operate more efficiently.

Warning! Data stored in printer memory is lost when the printer is unplugged.

Your printer has 4MB of standard printer memory. You can purchase printer memory cards having 4MB, 8MB, 16MB, 32MB, and 64MB of memory. You can install up to two optional printer memory cards in your printer, for a total of up to 132MB of SDRAM.

Flash Memory

The flash memory option is useful for storing information such as downloaded fonts, macros, symbol sets, logos, and forms. Use your printer driver or the MarkVision utility to download resources to flash memory.

Note: Data stored in flash memory is retained when the printer is unplugged.

You can install one flash memory option in your printer. Flash memory options available are 2, 4, 8, and 16MB.

See page 212 for instructions on installing the hard disk option, which provides memory storage similar to the flash memory option.

Installing Memory Options

This section offers instructions for installing either a printer memory option or a flash memory option card. You may install any one of the following memory configurations on your printer system board:

- One printer memory option.
- One flash memory option.
- One printer memory option *and* one flash memory option.
- Two printer memory options.

Warning! Printer memory and flash memory option cards are easily damaged by static electricity. Touch something metal before you touch an option card.

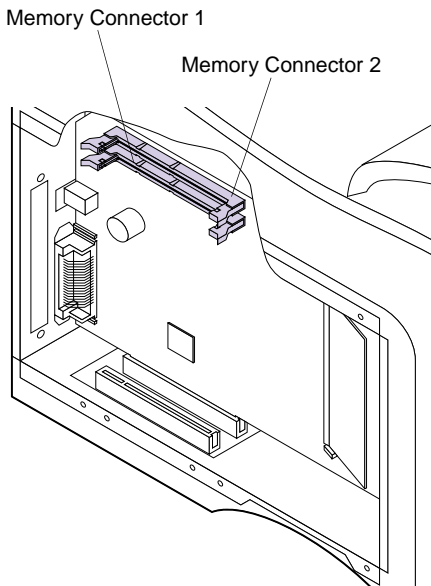

Before installing any option card, you must remove the printer system board cover.

1 Follow the steps in “Accessing the Printer System Board” on page 201.

2 Locate the two memory connectors on the system board.

Both memory connector 1 and memory connector 2 are capable of accepting either a printer memory option or a flash memory option card.

3 Follow the steps under “Removing Memory Options” on page 210 if you need to remove an option card before you install a new one. Otherwise, go to step 4.

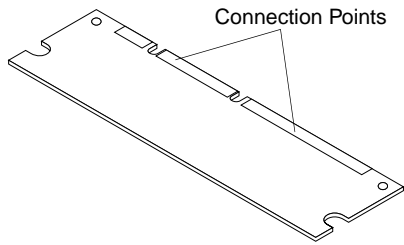

4 Unpack the new option card.

Avoid touching the connection points along the edge of the card. Save the packaging.

Warning! Printer memory option and flash memory option cards are easily damaged by static electricity. Touch something metal before you touch an option card.

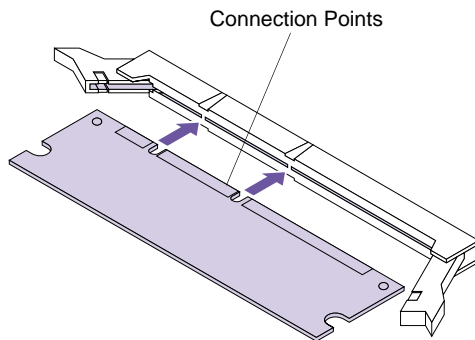

5 Hold the option card with the connection points pointing toward the system board as shown.

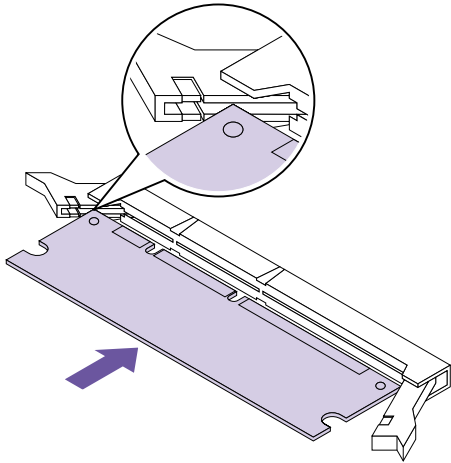

Note: This illustration is for the Optra M410. The connector for the Optra M412 is inverted. Invert the option card to insert it.

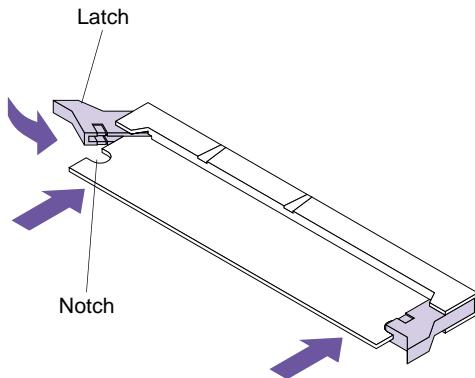

6 Insert the option card straight into the connector as shown.

Make sure the edges of the card fit into the slots located on each of the connector latches.

7 Push in on one side of the card and push in one of the latches until it snaps into place. Repeat for the other side of the card.

Make sure each latch fits over the notch located on either side of the option card.

8 Repeat steps 4 through 7 to install another memory option card in one of the memory connectors. Otherwise, go to step 9.

9 Continue with “Installing an Option Card” on page 216 if you have other option cards to install. Otherwise, go to “Closing the Printer System Board” on page 220.

Removing Memory Options

Warning! Printer memory option and flash memory option cards are easily damaged by static electricity. Touch something metal before you touch an option card.

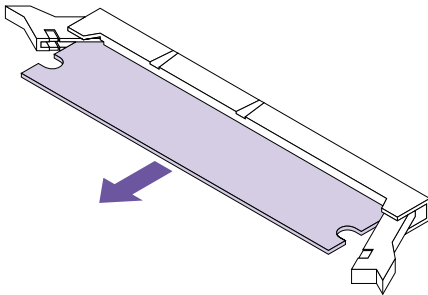
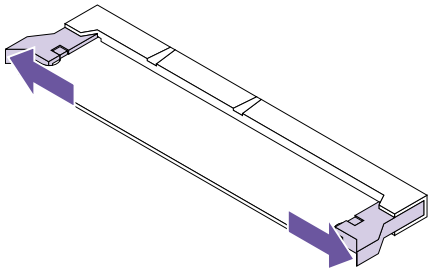

Before removing a memory option, follow the steps under “Accessing the Printer System Board” on page 201.

To remove a printer memory option or a flash memory option card:

- 1** Locate the option card that you want to remove.
- 2** Push the latches at each end of the memory connector away from the option card.
- 3** Pull the option card straight out of the memory connector.
- 4** Place the option card in its original packaging.
If you did not save the packaging, wrap the option card in paper and store it in a box.
- 5** Follow the steps under “Installing Memory Options” on page 207 if you need to install a new printer memory option or flash memory option card. Otherwise, go to step 6.
- 6** Continue with “Closing the Printer System Board” on page 220.

Understanding Option Cards

Note: Only one option card can be installed in your printer at a time.

Four kinds of option cards are available for your printer:

- Internal print server option card
- Tri-Port interface option card
- Hard disk option
- Parallel/USB interface option card

Refer to the documentation that is included with each option card for detailed information about that specific card.

The installation instructions are the same for each type of option card; therefore, they are grouped together. Installation instructions begin on page 216.

Internal Print Server (Internal Network Adapter or INA)

An optional internal print server lets you connect your printer to a local area network (LAN). You can install one print server in your printer. There are MarkNet™ cards available to support the following topologies:

- Ethernet (100BaseTX, 10BaseT, 10Base2)
- Token-Ring (DB9 or RJ45)

Internal print servers have a similar size and shape. Make sure the network port on the card corresponds to your network cable requirements. Refer to the documentation that came with the print server for more information.

Installing the Optional Internal Print Server

To install, complete the following two sections in order:

- “Accessing the Printer System Board” on page 201
- “Installing an Option Card” on page 216

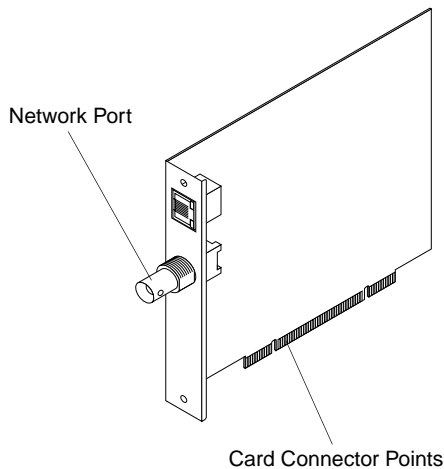

Tri-Port Interface Option Card

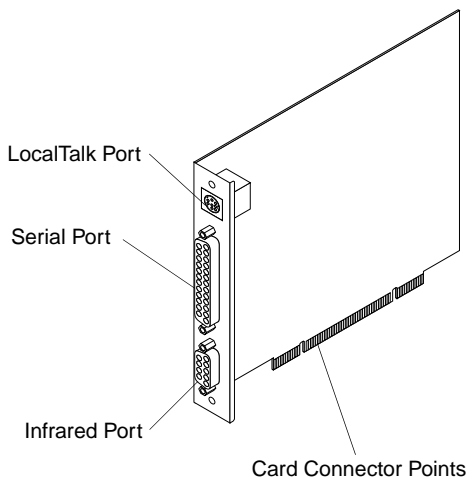

The Tri-Port interface option card lets you connect to:

- A LocalTalk network
- Serial interface (RS-232C or Serial RS-422A)
- An infrared adapter

For information about the LocalTalk network, see “LocalTalk Menu” on page 96.

For more information about serial interface, see “Serial Menu” on page 87.

An infrared adapter receives an infrared beam that allows you to print remotely to an IrDA-compatible computer. For more information, see “Infrared Menu” on page 93.

Installing the Tri-Port Interface Option Card

To install, complete the following two sections in order:

- “Accessing the Printer System Board” on page 201
- “Installing an Option Card” on page 216

Hard Disk Option

Note: Data stored on the hard disk option is kept in memory when the printer is turned off.

Like the flash memory option, the hard disk option is useful for storing information such as downloaded fonts, macros, and symbol sets.

You can also use the hard disk option to store incoming print jobs in a buffer until they print. Since hard disk memory provides permanent storage, job buffering to the hard disk prevents the loss of print job data if the printer loses power. It may also free your application faster for other work. Job buffering is only available for jobs transmitted across the standard parallel and USB interface.

You can purchase:

- A hard disk with an adapter card already installed.
- A hard disk that supports Optra Forms™ with an adapter card already installed. Refer to *Optra Forms* for more information.
- A hard disk adapter card for installing a separately purchased hard disk.

Complete the following instructions to attach the hard disk to the adapter card. If your disk is already attached to a card, go to “Accessing the Printer System Board” on page 201.

Attaching a Hard Disk to the Adapter Card

You can use the adapter card with any hard disk meeting the following criteria:

- 2.5-inch platter
- ATA-2 (IDE) interface
- Maximum thickness of 15 mm (.59 in.)

To attach the hard disk to the adapter card:

- 1** Align the connector pins on the end of the hard disk with the connector on the back of the adapter card.

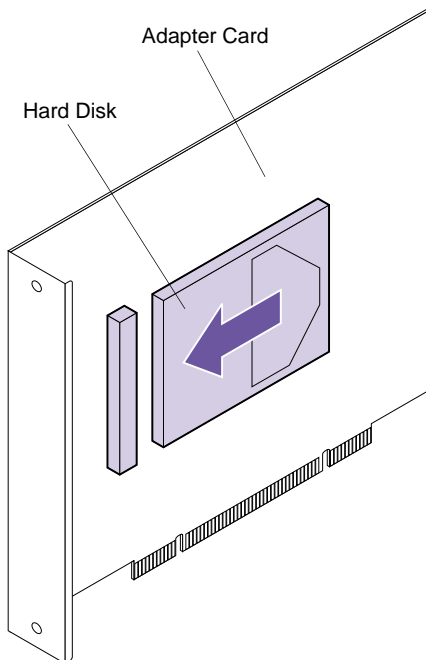

2 Push the hard disk securely into the connector.

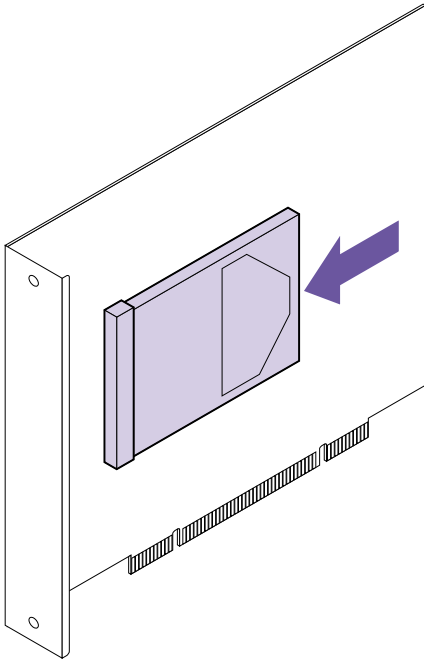

3 Turn the adapter card over and insert the four screws. Securely tighten each screw.

Installing the Hard Disk Option Card

To install, complete the following two sections in order:

- “Accessing the Printer System Board” on page 201
- “Installing an Option Card” on page 216

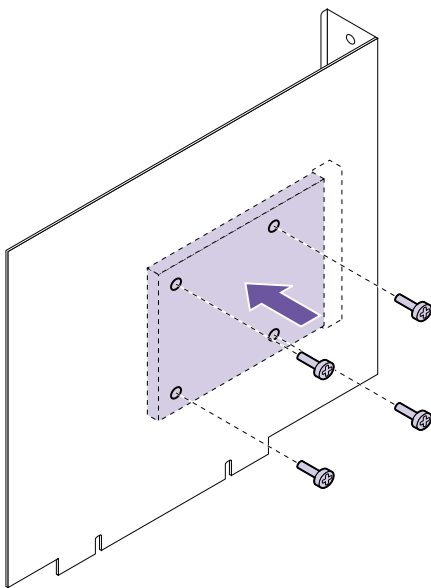

Parallel/USB Interface Option Card

The parallel/USB interface option card lets you connect your printer to a parallel interface. You can also use the USB (Universal Serial Bus) port to connect your printer to a computer. For more information about USB, see “USB Menu” on page 99.

Installing the Parallel/USB Interface Option Card

To install, complete the following two sections in order:

- “Accessing the Printer System Board” on page 201
- “Installing an Option Card” on page 216

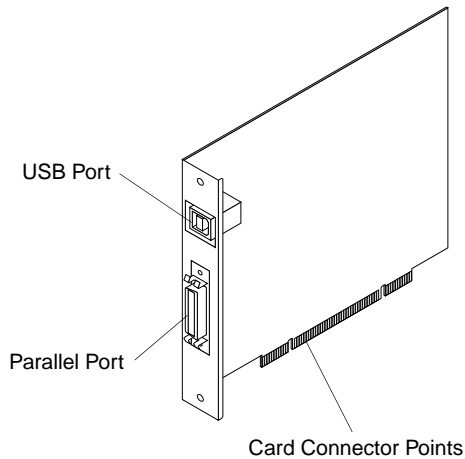

Installing an Option Card

Warning! The option card is easily damaged by static electricity. Touch something metal before you touch the card.

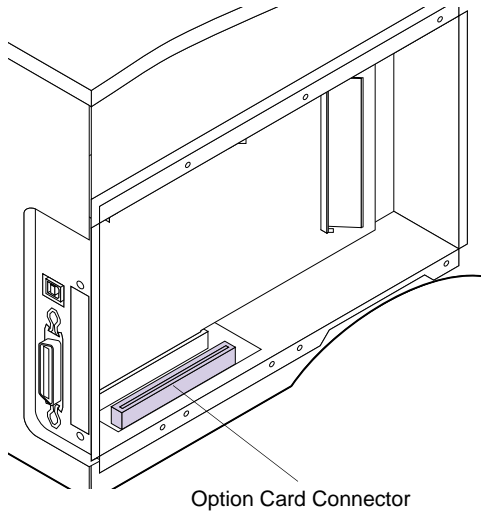

Before installing an option card, follow the steps under “Accessing the Printer System Board” on page 201.

To install a hard disk option card, optional internal print server, Tri-Port interface option card, or parallel/USB interface option card:

- 1** Locate the option card connector on the printer system board.
- 2** Follow the steps under “Removing an Option Card” on page 219 if you need to remove an option card before installing another one. Otherwise, go to step 3.

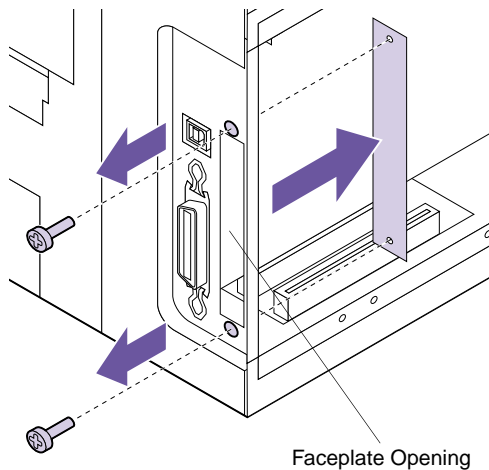

3 Remove the metal plate covering the connector slot.

a Locate the two screws on the back of the printer that attach the metal plate to the slot.

b Remove and save the two screws. Remove and discard the plate.

4 Unpack the option card.

Save the packing materials.

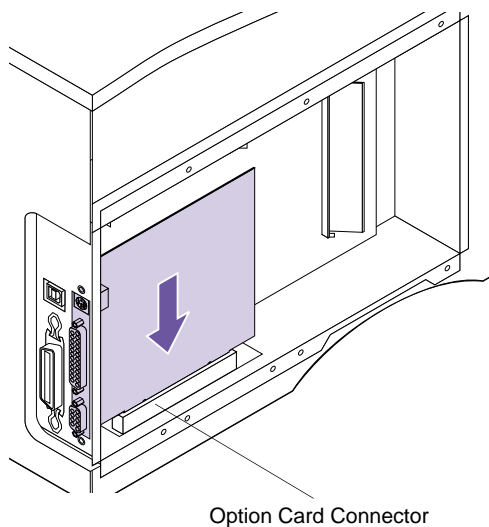

5 Align the connector on the option card with the connector on the system board.

The cable connectors on the side of the option card must fit through the opening in the faceplate.

6 Push the option card firmly into the option card connector on the system board.

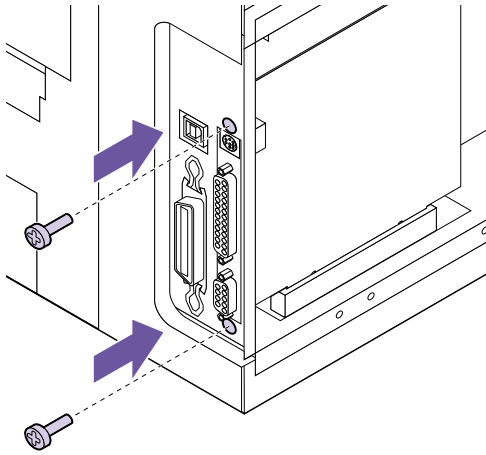

- 7** Insert the two screws saved from the metal plate (or the extra screws shipped with the option card) into the holes on either side of the connector slot.
- 8** Gently tighten the screws to secure the card to the system board.
- 9** Continue with “Closing the Printer System Board” on page 220.

Removing an Option Card

Warning! The option card is easily damaged by static electricity. Touch something metal before you touch the card.

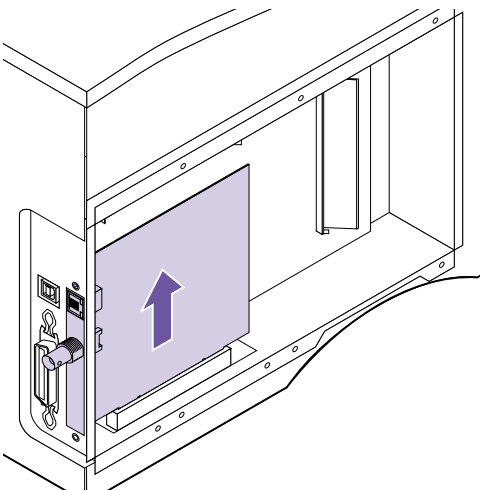
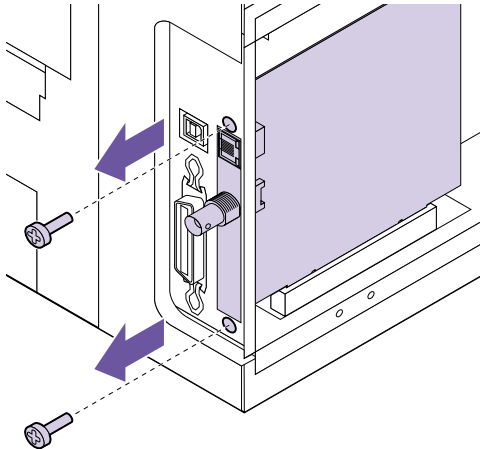

Before removing an option card, follow the steps under “Accessing the Printer System Board” on page 201.

To remove an option card:

- 1 Remove the two screws on either side of the connector slot located on the back of the printer.**
- 2 Pull the option card straight out of the system board connector.**
- 3 Place the option card in its original packaging.**
If you did not save the packaging, wrap the card in paper and store it in a box.
- 4 Follow the steps under “Installing an Option Card” on page 216 if you need to install an option card. Otherwise, go to step 5.**
- 5 Continue with “Closing the Printer System Board” on page 220.**

Closing the Printer System Board

After you have installed all of your options on the printer system board, reattach the shield and close the side door:

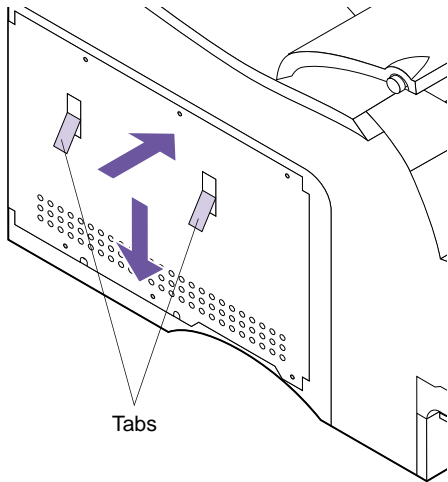

- 1** Grasp the shield by the tabs and align the three keyholes on the shield with the top three screws on the side of the printer.
- 2** Holding the shield by the tabs, slide it down.
- 3** Tighten all six screws.

- 4 Hold the side door slightly to the left of the printer and place the latches located on the back edge of the side door against the metal shield.

The edge of the metal shield fits into the latches. The top latch fits inside the back of the printer.

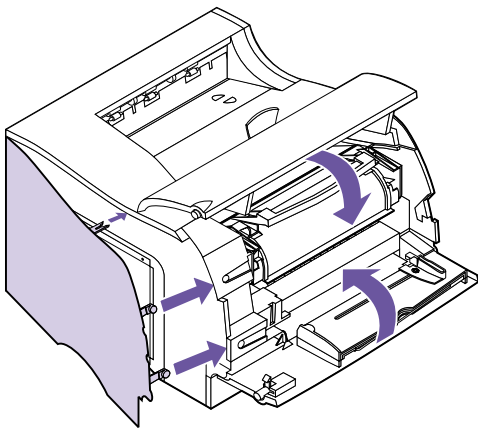
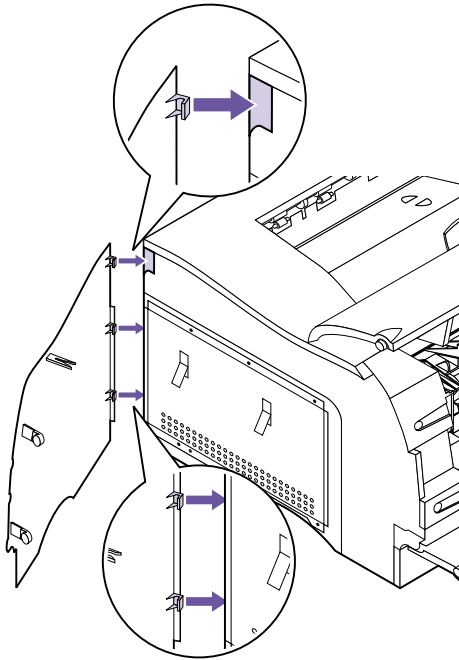

- 5 Close the side door, pressing on the side door latches to snap it into place.
- 6 Close the upper and lower front doors.
- 7 Reconnect all cables to the back of the printer.
- 8 Reconnect the printer power cord to the printer and a properly grounded electrical outlet.
- 9 Turn the printer power On (|).
- 10 Make sure the Ready message appears on the operator panel display.

If an error message appears, see “Understanding Printer Messages” on page 151.

Note: To verify options are installed properly, see “Verifying the Installation of Options” on page 229.

Optional 500-Sheet Drawer

12

Decide on a location to set the support unit. *The printer will be placed on top of it*, so allow enough space for easy paper access. The location must be sturdy and large enough to accommodate the printer and the optional 500-sheet drawer.

Installing the Optional Drawer

The optional drawer consists of a support unit and an input tray. To install the optional 500-sheet drawer:

- 1 Turn the printer power Off (O).**
- 2 Unplug the printer power cord.**
- 3 Disconnect all cables from the back of the printer.**
- 4 Remove the support unit from its packaging.**

Remove any packing tape.

Caution! To avoid electrical shock hazards, make sure your computer power is Off (O) and unplug all computer equipment before connecting cables.

5 Pull the input tray out of the support unit.

Remove any packing material and tape from the input tray.

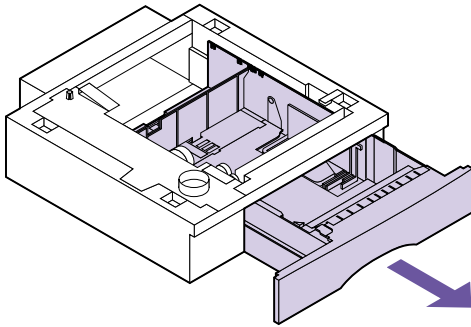

6 Grasp the support unit on each side at opposite corners and move it to the location being used.

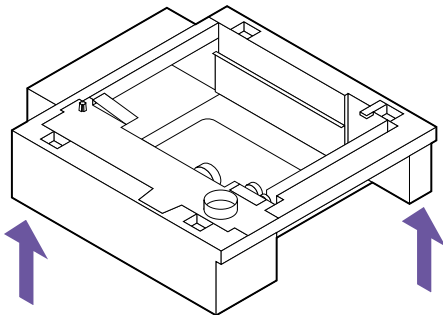

7 Notice the following parts located on the top surface of the optional support unit: the tab, the round hole, and the four square holes.

8 Lift the printer by the handholds or ask someone to help you lift the printer.

The bottom surface of the printer has matching holes or feet that accommodate the tab, round hole, and four square holes.

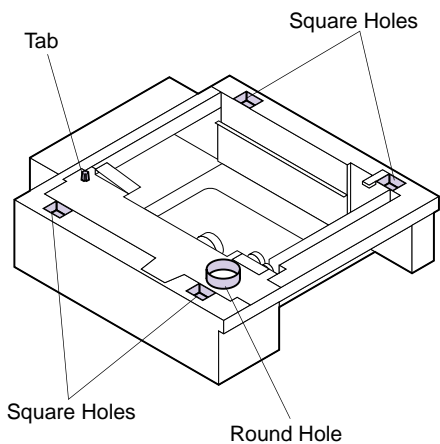

Caution! Make sure your fingers are not under the printer when you set it down.

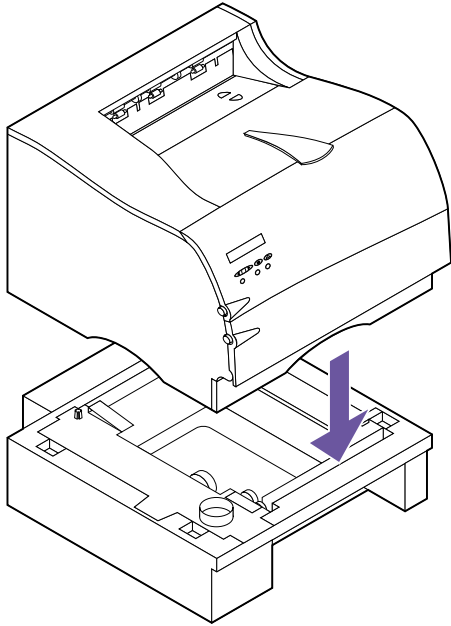

Note: Verify that the optional drawer is installed properly. See “Verifying the Installation of Options” on page 229.

9 Place the printer on top of the support unit.

Make sure the edges of the printer and the support unit are aligned properly.

10 Load print material in the input tray.

See “Loading Print Material” on page 124 for more information.

11 Install the input tray in the support unit.

12 Reconnect all cables to the back of the printer.

13 Plug the printer power cord into a properly grounded electrical outlet.

14 Turn the printer power On (|).

15 When Ready displays, press Menu> to enter the menus.

16 Set the PAPER SIZE, PAPER TYPE, and PAPER LENGTH menu settings for this paper source.

See **PAPER SIZE** on page 45, **PAPER TYPE** on page 47, and **PAPER LENGTH** on page 52 for more information.

17 Press Go to return to the Ready state.

If an error message appears, see “Understanding Printer Messages” on page 151.

13

Infrared Adapter

You can use an infrared adapter to print remotely to an IrDA-compatible computer equipped with an infrared port.

The Tri-Port interface option card, which includes an infrared port, lets you connect the infrared adapter to your printer. For more information, see “Tri-Port Interface Option Card” on page 212. If you need to install the Tri-Port interface option card, see “Installing an Option Card” on page 216.

After you install the Tri-Port interface option card, complete the following steps to connect the infrared adapter to your printer.

Connecting the Cable and Using the Infrared Adapter

To connect the infrared adapter to your printer:

- 1 Unplug the printer power cord.**
- 2 Locate the infrared port on the back of your printer.**

The infrared port is attached to the Tri-Port interface option card installed in your printer.

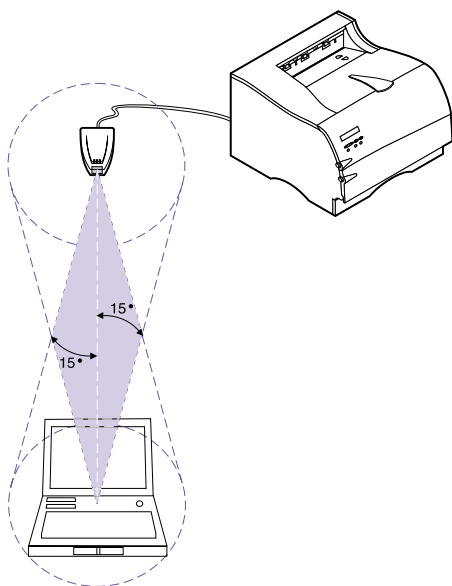
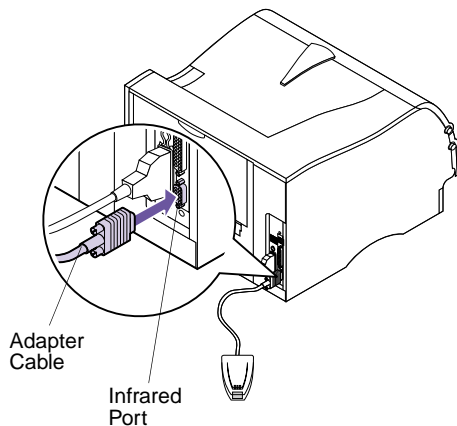

3 Plug the adapter cable into the infrared port.

4 Reconnect the printer power cord to a properly grounded electrical outlet.

If any light on the infrared adapter comes on when the printer is plugged in, the adapter is connected to the port correctly.

5 Aim the computer infrared port at the infrared port on the front of the Tri-Port interface option card.

Refer to the documentation that came with your computer for information about your computer infrared port.

6 Draw an imaginary line between the two infrared ports. Aim the infrared port on your computer within 15 degrees of either side of this line, as shown.

7 Send a job to print.

If the job does not print correctly, see **Infrared Adapter** on page 181.

14

Verifying the Installation of Options

You can verify that printer options are properly installed by printing a menu settings page.

A menu settings page lists:

- All printer settings in the operator panel menus and their default values.
- All installed features and options, such as the optional 500-sheet drawer, internal print server (also called an internal network adapter or INA), flash memory option, printer memory option, and hard disk option.
- Amount of available printer memory.
- Other printer settings.

Printing the Menu Settings Page

Before printing the menu settings page, make sure the selected paper source holds letter-, legal-, or A4-size paper, the **PAPER SIZE** setting is set to the correct size, and the **PAPER TYPE** setting for the paper source is **Plain Paper**.

To print a menu settings page:

- 1 Make sure the printer power is On (|) and the Ready status message appears on the display.**

If you need help, see “Using the Operator Panel” on page 34 to identify the display and operator panel buttons.

- 2 Press Menu> or <Menu to enter the menus.**
- 3 Continue to press and release Menu> or <Menu until you see UTILITIES MENU.**
- 4 Press Select.**
- 5 Press Menu> until Print Menus appears on the second line of the display.**
- 6 Press Select.**

The message **Printing Menu Settings** appears and remains on the operator panel display until the page prints. The printer returns to the **Ready** state after the menu settings page prints.

If an error message appears, see “Understanding Printer Messages” on page 151.

- 7 Check to see if the option you installed is listed.**

All installed options are listed on the menu settings page under Installed Features.

If an installed option does not appear on the page, it is not installed correctly or aligned properly. Turn the printer power Off (O), unplug the printer power cord, reinstall the option, and print the menu settings page again.

A

Understanding Fonts

This appendix contains basic information about fonts, their characteristics, and the specific fonts available in PCL 6 and PostScript 3 emulations.

Typefaces and Fonts

A *font* is a set of characters and symbols created with a distinct design. The distinct design is called a *typeface*. The typefaces you select add personality to a document. Well-chosen typefaces make a document easier to read.

The printer has numerous resident fonts in PCL 6 and PostScript 3 emulations. See “Resident Fonts” on page 235 for a listing of all resident fonts.

Weight and Style

Typefaces are often available in different weights and styles. These variations modify the original typeface so you can, for example, emphasize important words in text or highlight book titles. The different weights and styles are designed to complement the original typeface.

Weight refers to the thickness of the lines that form the characters. Thicker lines result in darker characters. Some words commonly used to describe the weight of a typeface are bold, medium, light, black and heavy.

Style refers to other typeface modifications, such as tilt or character width. Italic and oblique are styles where the characters are tilted. Narrow, condensed and extended are three common styles that modify the character widths.

Some fonts combine several weight and style modifications; for example, Helvetica Narrow Bold Italic. A group of several weight and style variations of a single typeface is called a *typeface family*. Most typeface families have four variations: regular, italic, bold, and bold italic. Some families have more variations, as the following illustration for the Helvetica typeface family shows:

Helvetica	ABCDEFGHIJKLMNOPQRSTUVWXYZ
<i>Helvetica-Italic</i>	<i>ABCDEFGHIJKLMNOPQRSTUVWXYZ</i>
Helvetica-Bold	ABCDEFGHIJKLMNOPQRSTUVWXYZ
<i>Helvetica-BoldItalic</i>	<i>ABCDEFGHIJKLMNOPQRSTUVWXYZ</i>
Helvetica-Narrow	ABCDEFGHIJKLMNOPQRSTUVWXYZ
<i>Helvetica-Narrow Italic</i>	<i>ABCDEFGHIJKLMNOPQRSTUVWXYZ</i>
Helvetica-Narrow Bold	ABCDEFGHIJKLMNOPQRSTUVWXYZ
<i>Helvetica-Narrow-BoldItalic</i>	<i>ABCDEFGHIJKLMNOPQRSTUVWXYZ</i>

Pitch and Point Size

The size of a font is specified as either a pitch or point size, depending on whether the font is fixed space or proportional.

In fixed space fonts, each character has the same width. *Pitch* is used to specify the size of fixed space fonts. It is a measure of the number of characters that will print in one horizontal inch of type. For example, all 10-pitch fonts print 10 characters per inch (cpi) and all 12-pitch fonts print 12 cpi:

Courier	10 Pitch	1234567890
Courier-Bold	10 Pitch	1234567890
Courier	12 Pitch	123456789012
Courier-Bold	12 Pitch	123456789012

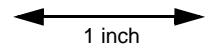

In *proportional* (or *typographic*) fonts, every character can have a different width. Since proportional fonts have characters with different widths, the font size is specified in point size, not pitch. *Point size* refers to the height of the characters in the font. A *point* is defined as 1/72 inch. The characters in a font printed at 24 point will be twice as large as the characters in the same font printed at 12 point. The following illustration shows samples of a font printed in different point sizes:

48 point 36 point

24 point 18 point 12 point 10 point

The point size of a font is defined as the distance from the top of the tallest character in the font to the bottom of the lowest character in the font. Due to the definition of point size, different fonts printed at the same point size may appear quite different in size. This is because there are other font parameters that affect how the font looks. However, the point size of a font is an excellent specification of the relative size of a font. The following examples illustrate two very different proportional fonts at 14 point:

ITC Avant Garde
abcdefghABCDEFGH

ITC Zapf Chancery
abcdefghABCDEFGH

Bitmapped and Scalable Fonts

The printer uses both bitmapped and scalable fonts.

Bitmapped fonts are stored in printer memory as pre-defined patterns of bits that represent a typeface at a specific size, style and resolution. An example of a character from a bitmapped font is shown at left.

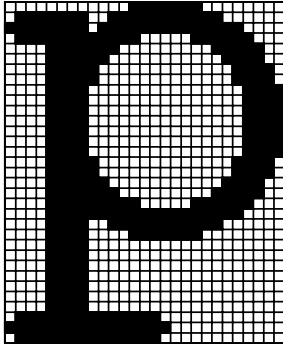

Bitmapped fonts are available in different type styles and point sizes as downloadable fonts. Contact your point of purchase for more information about downloadable fonts.

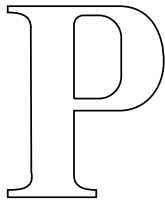

Scalable fonts are stored as computer programs that define the outlines of the characters in the font. Each time you print characters from a scalable font, the printer creates a bitmap of the characters at the point size you choose and saves it temporarily in printer memory. These temporary bitmapped fonts are deleted when you turn off or reset the printer. Scalable fonts provide the flexibility of printing in many different point sizes.



Your printer uses different scalable font formats for downloading fonts to the printer. PCL 6 emulation uses *IntelliFont* and *TrueType* scalable fonts. PostScript 3 emulation uses *Type 1* and *TrueType* scalable fonts. There are thousands of different scalable fonts available in these different font formats from numerous font suppliers.

If you plan to use many downloadable bitmapped or scalable fonts or if you plan to use many different sizes of scalable fonts, you may need to purchase additional memory for your printer. See page 206 for more information.

Resident Fonts

Your printer is equipped with resident fonts stored permanently in printer memory. Different fonts are available in PCL 6 and PostScript 3 emulations. Some of the most popular typefaces, like Courier and Times New Roman, are available for all printer languages.

The following tables list all the fonts resident in your printer. See page 242 for instructions on how to print samples of the fonts. You can select the resident fonts from your software application, or from the operator panel if you are using PCL 6 emulation.

Resident Scalable Fonts

PCL 6 Emulation	PostScript 3 Emulation
Albertus Medium	AlbertusMT
	AlbertusMT-Italic
	AlbertusMT-Light
Albertus Extra Bold	
Antique Olive	AntiqueOlive-Roman
Antique Olive Italic	AntiqueOlive-Italic
Antique Olive Bold	AntiqueOlive-Bold
	AntiqueOlive-Compact
Arial	ArialMT
Arial Italic	Arial-ItalicMT
Arial Bold	Arial-BoldMT
Arial Bold Italic	Arial-BoldItalicMT
ITC Avant Garde Book	AvantGarde-Book
ITC Avant Garde Book Oblique	AvantGarde-BookOblique
ITC Avant Garde Demi	AvantGarde-Demi
ITC Avant Garde Demi Oblique	AvantGarde-DemiOblique
ITC Bookman Light	Bookman-Light
ITC Bookman Light Italic	Bookman-LightItalic
ITC Bookman Demi	Bookman-Demi
ITC Bookman Demi Italic	Bookman-DemiItalic
Clarendon Condensed Bold	

Resident Scalable Fonts (continued)

PCL 6 Emulation	PostScript 3 Emulation
Coronet	Coronet-Regular
CourierPS	Courier
CourierPS Oblique	Courier-Oblique
CourierPS Bold	Courier-Bold
CourierPS Bold Italic	Courier-BoldOblique
CG Omega	
CG Omega Bold	
CG Omega Italic	
CG Omega Bold Italic	
Garamond Antiqua	Garamond-Antiqua
Garamond Halbfett	Garamond-Halbfett
Garamond Kursiv	Garamond-Kursiv
Garamond Kursiv Halbfett	Garamond-KursivHalbfett
Helvetica Light	Helvetica-Light
Helvetica Light Oblique	Helvetica-LightOblique
Helvetica Black	Helvetica-Black
Helvetica Black Oblique	Helvetica-BlackOblique
Helvetica	Helvetica
Helvetica Italic	Helvetica-Oblique
Helvetica Bold	Helvetica-Bold
Helvetica Bold Italic	Helvetica-BoldOblique
Helvetica Narrow	Helvetica-Narrow
Helvetica Narrow Italic	Helvetica-Narrow-Oblique
Helvetica Narrow Bold	Helvetica-Narrow-Bold
Helvetica Narrow Bold Italic	Helvetica-Narrow-BoldOblique
CG Times	Intl-CG-Times
CG Times Italic	Intl-CG-Times-Italic
CG Times Bold	Intl-CG-Times-Bold
CG Times Bold Italic	Intl-CG-Times-BoldItalic

Resident Scalable Fonts (continued)

PCL 6 Emulation	PostScript 3 Emulation
Univers Medium	Intl-Univers-Medium
Univers Medium Italic	Intl-Univers-MediumItalic
Univers Bold	Intl-Univers-Bold
Univers Bold Italic	Intl-Univers-BoldItalic
Courier	Intl-Courier
Courier Italic	Intl-Courier-Oblique
Courier Bold	Intl-Courier-Bold
Courier Bold Italic	Intl-Courier-BoldOblique
Letter Gothic	LetterGothic
Letter Gothic Italic	LetterGothic-Slanted
Letter Gothic Bold	LetterGothic-Bold
	LetterGothic-BoldSlanted
Marigold	Marigold
Century Schoolbook Roman	NewCenturySchlbk-Roman
Century Schoolbook Italic	NewCenturySchlbk-Italic
Century Schoolbook Bold	NewCenturySchlbk-Bold
Century Schoolbook Bold Italic	NewCenturySchlbk-BoldItalic
	Optima
	Optima-Bold
	Optima-BoldItalic
	Optima-Italic
Palatino Roman	Palatino-Roman
Palatino Italic	Palatino-Italic
Palatino Bold	Palatino-Bold
Palatino Bold Italic	Palatino-BoldItalic
SymbolPS	Symbol
Symbol	
Times Roman	Times-Roman
Times Italic	Times-Italic

Resident Scalable Fonts (continued)

PCL 6 Emulation	PostScript 3 Emulation
Times Bold	Times-Bold
Times Bold Italic	Times-BoldItalic
Times New Roman	TimesNewRomanPSMT
Times New Roman Italic	TimesNewRomanPS-ItalicMT
Times New Roman Bold	TimesNewRomanPS-BoldMT
Times New Roman Bold Italic	TimesNewRomanPS-BoldItalicMT
	Univers
	Univers-Oblique
	Univers-Bold
	Univers-BoldOblique
Univers Condensed Medium	Univers-Condensed
Univers Condensed Medium Italic	Univers-CondensedOblique
Univers Condensed Bold	Univers-CondensedBold
Univers Condensed Bold Italic	Univers-CondensedBoldOblique
Wingdings	Wingdings-Regular
ITC Zapf Chancery Medium Italic	ZapfChancery-MediumItalic
ITC Zapf Dingbats	ZapfDingbats

Resident Bitmapped Fonts

PCL 6 Emulation	PostScript 3 Emulation
Line Printer 16	
POSTNET Barcode	

Symbol Sets

A *symbol set* is the collection of alphabetic and numeric characters, punctuation, and special characters available in the font you select. Symbol sets support the requirements for different languages or specific applications, such as math symbols used for scientific text.

In PCL 6 emulation, a symbol set also defines which character will print for each key on the keyboard (or more specifically, for each *code point*). Some applications require different characters at some code points. To support multiple applications and languages, your printer has 83 symbol sets for the resident PCL 6 emulation fonts.

Symbol Sets for PCL 6 Emulation

Not all font names support all of the symbol sets listed. Refer to the *Technical Reference* to determine which symbols sets are supported by each font name.

- ABICOMP Brazil/Portugal
- ABICOMP International
- DeskTop
- Legal
- MC Text
- Microsoft Publishing
- Russian-GOST
- Ukrainian
- PCL ITC Zapf Dingbats
- PS ITC Zapf Dingbats
- PS Math
- PS Text
- Pi Font
- Symbol
- Wingdings
- POSTNET Barcode
- ISO : German
- ISO : Spanish
- ISO 2: IRV (Int'l Ref Version)
- ISO 4: United Kingdom
- ISO 6: ASCII
- ISO 10: Swedish
- ISO 11: Swedish for Names
- ISO 14: JIS ASCII
- ISO 15: Italian
- ISO 16: Portuguese
- ISO 17: Spanish
- ISO 21: German
- ISO 25: French
- ISO 57: Chinese
- ISO 60: Norwegian version 1
- ISO 61: Norwegian version 2

ISO 69: French
ISO 84: Portuguese
ISO 85: Spanish
ISO 8859-1 Latin 1 (ECMA-94)
ISO 8859-2 Latin 2
ISO 8859-5 Latin/Cyrillic
ISO 8859-7 Latin/Greek
ISO 8859-9 Latin 5
ISO 8859-10 Latin 6
ISO 8859-15 Latin 9
PC-8 Bulgarian
PC-8 Danish/Norwegian (437N)
PC-8 Greek Alternate (437G)
PC-8 Turkish (437T)
PC-8 Latin/Greek
PC-8 PC Nova
PC-8 Polish Mazovia
PC-8 Code Page 437
PC-775 Baltic (PC-8 Latin 6)
PC-850 Multilingual
PC-851 Greece
PC-852 Latin 2
PC-853 Latin 3 (Turkish)
PC-855 Cyrillic
PC-857 Latin 5 (Turkish)
PC-858 Multilingual Euro
PC-860 Portugal
PC-861 Iceland
PC-863 Canadian French
PC-865 Nordic
PC-866 Cyrillic
PC-869 Greece
PC-911 Katakana
PC-1004 OS/2
Math-8
Greek-8
Turkish-8
Roman-8
Roman-9
Roman Extension
Ventura ITC Zapf Dingbats
Ventura International
Ventura Math
Ventura US
Windows 3.0 Latin 1
Windows 98 Cyrillic
Windows 98 Greek
Windows 98 Latin 1
Windows 98 Latin 2
Windows 98 Latin 5
Windows 98 Latin 6 (Baltic)

Downloadable Fonts

You can download scalable fonts in PostScript 3 emulation and either scalable or bitmapped fonts in PCL 6 emulation. Fonts can be downloaded to printer memory or to a flash memory option or hard disk option. Fonts downloaded to flash memory or hard disk remain in memory even after the printer language changes, the printer resets, or the printer is turned off.

The MarkVision utility includes a remote management function that lets you manipulate the font files you have downloaded to flash memory or hard disk. See page 25 for more information about MarkVision.

Printing a Font Sample List

To print samples of all the fonts currently available for your printer:

- 1** Make sure the printer power is On (|) and the Ready status message appears on the display.
- 2** Press Menu> or <Menu to enter the menus.
- 3** Continue to press and release Menu> until you see UTILITIES MENU.
- 4** Press Select.
- 5** Press Menu> until Print Fonts appears.
- 6** Press Select.
- 7** Press Menu> or <Menu until either PCL Fonts or PS Fonts appears on the second line of the display.
 - Select **PCL Fonts** to print a listing of the fonts available to the PCL emulator.
 - Select **PS Fonts** to print a listing of the fonts available to the PostScript 3 emulator.
- 8** Press Select.

The message **Printing Font List** appears and remains on the operator panel display until the page prints. The printer returns to the **Ready** state after the font sample list prints.

B

Notices

Electronic Emissions Notices

Electronic emission information for your printer varies, depending on whether or not you have an optional network adapter installed.

Warning

With a network adapter installed, this is a Class A product. In a domestic environment, this product may cause radio interference, in which case the user may be required to take adequate measures.

Without a Network Adapter Installed

Federal Communications Commission (FCC) Compliance Information Statement

The Lexmark Optra M410 and M412 laser printers, Type 4045, have been tested and found to comply with the limits for a Class B digital device, pursuant to Part 15 of the FCC Rules. Operation is subject to the following two conditions: (1) this device may not cause harmful interference, and (2) this device must accept any interference received, including interference that may cause undesired operation.

The FCC Class B limits are designed to provide reasonable protection against harmful interference in a residential installation. This equipment generates, uses and can radiate radio frequency energy and, if not installed and used in accordance with the instructions, may cause harmful interference to radio communications. However, there is no guarantee that interference will not occur in a particular installation. If this equipment does cause harmful interference to radio or television reception, which can be determined by turning the equipment off and on, the user is encouraged to try to correct the interference by one or more of the following measures:

- Reorient or relocate the receiving antenna.
- Increase the separation between the equipment and receiver.
- Connect the equipment into an outlet on a circuit different from that to which the receiver is connected.
- Consult your point of purchase or service representative for additional suggestions.

The manufacturer is not responsible for any radio or television interference caused by using other than recommended cables or by unauthorized changes or modifications to this equipment. Unauthorized changes or modifications could void the user's authority to operate this equipment.

To assure compliance with FCC regulations on electromagnetic interference for a Class B computing device, use a properly shielded and grounded cable such as Lexmark part number 1329605 for parallel and 12A2405 for USB. Use of a substitute cable not properly shielded and grounded may result in a violation of FCC regulations.

Any questions regarding this compliance information statement should be directed to:

Director of Lab Operations
Lexmark International, Inc.
740 West New Circle Road
Lexington, KY 40550
(606) 232-3000

Industry Canada Compliance Statement

This Class B digital apparatus meets all requirements of the Canadian Interference-Causing Equipment Regulations.

Avis de conformité aux normes d'Industrie Canada

Cet appareil numérique de la classe B respecte toutes les exigences du Règlement sur le matériel brouilleur du Canada.

European Community (EC) Directives Conformity

This product is in conformity with the protection requirements of EC Council directives 89/336/EEC and 73/23/EEC on the approximation and harmonization of the laws of the Member States relating to electromagnetic compatibility and safety of electrical equipment designed for use within certain voltage limits.

A declaration of conformity with the requirements of the Directive has been signed by the Director of Manufacturing and Technical Support, Lexmark International, S.A., Boigny, France.

This product satisfies the Class B limits of EN 55022 and safety requirements of EN 60950.

With a Network Adapter Installed

Federal Communications Commission (FCC) Compliance Information Statement

The Lexmark Optra M410n and M412n laser printers, Type 4045, have been tested and found to comply with the limits for a Class A digital device, pursuant to Part 15 of the FCC Rules. Operation is subject to the following two conditions: (1) this device may not cause harmful interference, and (2) this device must accept any interference received, including interference that may cause undesired operation.

The FCC Class A limits are designed to provide reasonable protection against harmful interference when the equipment is operated in a commercial environment. This equipment generates, uses, and can radiate radio frequency energy and, if not installed and used in accordance with the instruction manual, may cause harmful interference to radio communications. Operation of this equipment in a residential area is likely to cause harmful interference in which case the user will be required to correct the interference at his own expense.

The manufacturer is not responsible for any radio or television interference caused by using other than recommended cables or by unauthorized changes or modifications to this equipment. Unauthorized changes or modifications could void the user's authority to operate this equipment.

Note: To assure compliance with FCC regulations on electromagnetic interference for a Class A computing device, use a properly shielded and grounded cable such as Lexmark part number 1329605 for parallel and 12A2405 for USB. Use of a substitute cable not properly shielded and grounded may result in a violation of FCC regulations.

Industry Canada Compliance Statement

This Class A digital apparatus meets all requirements of the Canadian Interference-Causing Equipment Regulations.

Avis de conformité aux normes d'Industrie Canada

Cet appareil numérique de la classe A respecte toutes les exigences du Règlement sur le matériel brouilleur du Canada.

European Community (EC) Directives Conformity

This product is in conformity with the protection requirements of EC Council directives 89/336/EEC and 73/23/EEC on the approximation and harmonization of the laws of the Member States relating to electromagnetic compatibility and safety of electrical equipment designed for use within certain voltage limits.

A declaration of conformity with the requirements of the Directive has been signed by the Director of Manufacturing and Technical Support, Lexmark International, S.A., Boigny, France.

This product satisfies the Class A limits of EN 55022 and safety requirements of EN 60950.

**The United Kingdom
Telecommunications Act
1984**

This apparatus is approved under the approval number NS/G/1234/J/100003 for the indirect connections to the public telecommunications systems in the United Kingdom.

**German Acoustics
Statement**

The following measurements were made in accordance with ISO 7779 and reported in conformance with ISO 9296.

Acoustics

1-Meter Average Sound Pressure, dBA	Optra M410	Optra M412
Printing	48 dBA	50 dBA
Idling	30 dBA	30 dBA

Energy Star



The EPA ENERGY STAR Computers program is a partnership effort with computer manufacturers to promote the introduction of energy-efficient products and to reduce air pollution caused by power generation.

Companies participating in this program introduce personal computers, printers, monitors, or fax machines that power down when they are not being used. This feature will cut the energy used by up to 50 percent. Lexmark is proud to be a participant in this program.

As an Energy Star Partner, Lexmark International, Inc. has determined that this product meets the Energy Star guidelines for energy efficiency.

Laser Notices

The following laser notice labels may be affixed to this printer as shown:

Laser Advisory Label

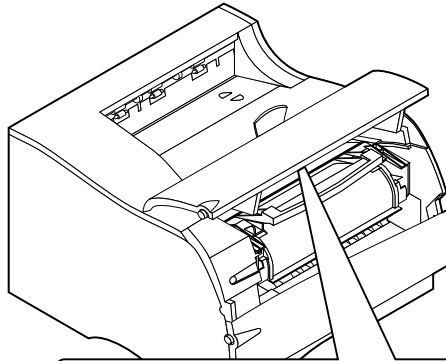

CAUTION -	Invisibile laser radiation when open and markoff defensed. Avoid exposure to beam.
ATTENTION -	Radiation laser invisible si le device n'est ouvert et non bloquée. Evitez l'exposition au rayon.
VORSICHT -	Unsichtbare Laserstrahlung wenn drucker offen und sperre gelöst. Nicht dem strahl aussetzen.
VOORZICHT -	Onzichtbare laserstraling wanneer de printer open is en niet vergrendeld. Vermijdt blootstelling aan straal.
ATTENZIONE -	Radiazione laser invisibile quando il dispositivo è aperto e non bloccato. Evitare l'esposizione diretta.
AVISO -	Radiacão laser invisível quando a tampa está aberta e o dispositivo não está bloqueado. Evite a exposição à luz radiação.
CUIDADO -	Radiație laser invizibilă cândva a aparaturii este deschisă și aparaturii este deblocată.
VARO!	Avantessa ja suojauslaitteet on irrotettava oltiin alittuna näkymättömien laser säteilylle. Älä käsitä säteilyä.
VARO!	Avantessa ja suojauslaitteet on irrotettava oltiin alittuna näkymättömien laser säteilylle. Älä käsitä säteilyä.
VARO!	Avantessa ja suojauslaitteet on irrotettava oltiin alittuna näkymättömien laser säteilylle. Älä käsitä säteilyä.
ADVARSEL -	Ungsynlig laserstråling når de er åbnet og sikkerhedsudrustningen er ude af funktion. Undgå udsættelse for stråling.
ADVARSEL -	Ungsynlig laserstråling når de er åbnet og sikkerhedsudrustningen er ude af funktion. Undgå udsættelse for stråling.
ADVARSEL -	Ungsynlig laserstråling når de er åbnet og sikkerhedsudrustningen er ude af funktion. Undgå udsættelse for stråling.
ATENCIÓN -	Radiación laser invisible a la zona de funcionamiento. No se conecte. Evite la exposición.
注意 -	開機時蓋を開くとレーザー放射線が放射される。レーザー放射線に直接曝露しないでください。
注意 -	開機時蓋を開くとレーザー放射線が放射される。レーザー放射線に直接曝露しないでください。
주의 -	개방 시 레이저 방사선이 방출됩니다. 레이저 빛에 노출되지 않도록 하십시오.

Class 1 Laser Statement Label

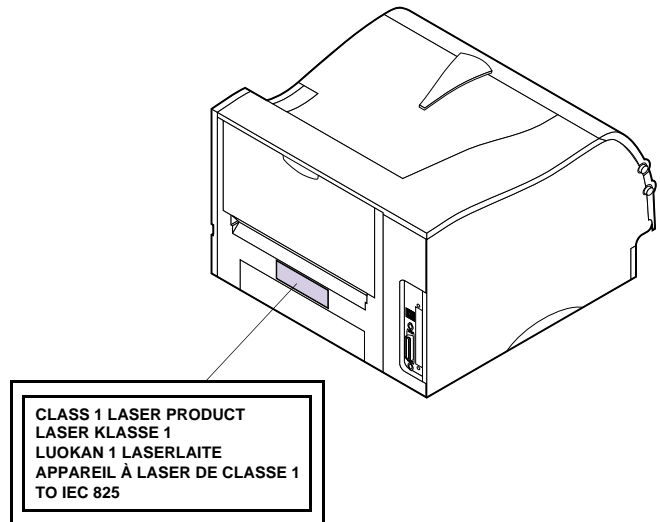

Laser Notice

The printer is certified in the U.S. to conform to the requirements of DHHS 21 CFR Subchapter J for Class I (1) laser products, and elsewhere is certified as a Class I laser product conforming to the requirements of IEC 60825-1.

Class I laser products are not considered to be hazardous. The printer contains internally a Class IIb (3b) laser that is nominally a 5 milliwatt aluminum gallium arsenide laser operating in the wavelength region of 770-795 nanometers. The laser system and printer are designed so there is never any human access to laser radiation above a Class I level during normal operation, user maintenance, or prescribed service condition.

Laser

Der Drucker erfüllt gemäß amtlicher Bestätigung der USA die Anforderungen der Bestimmung DHHS (Department of Health and Human Services) 21 CFR Teil J für Laserprodukte der Klasse I (1). In anderen Ländern gilt der Drucker als Laserprodukt der Klasse I, der die Anforderungen der IEC (International Electrotechnical Commission) 60825-1 gemäß amtlicher Bestätigung erfüllt.

Laserprodukte der Klasse I gelten als unschädlich. Der Drucker ist intern mit einem Laser der Klasse IIb (3b) ausgestattet. Hierbei handelt es sich nominell um einen 5-Milliwatt-Aluminium-Galliumarsenidlaser, der in einem Wellenlängenbereich von 770 bis 795 Nanometern arbeitet. Das Lasersystem und der Drucker sind so konzipiert, daß im Normalbetrieb, bei der Wartung durch den Benutzer oder bei ordnungsgemäßer Wartung durch den Kundendienst Laserbestrahlung, die die Klasse I übersteigen würde, Menschen keinesfalls erreicht.

Avis relatif à l'utilisation de laser

Pour les Etats-Unis : cette imprimante est certifiée conforme aux provisions DHHS 21 CFR alinéa J concernant les produits laser de Classe I (1). Pour les autres pays : cette imprimante répond aux normes IEC 60825-1 relatives aux produits laser de Classe I.

Les produits laser de Classe I sont considérés comme des produits non dangereux. L'imprimante contient un laser interne de classe IIIb (3b) ; il s'agit d'un laser semi-conducteur à arsénure de gallium de 5 mw en aluminium utilisant la plage de la longueur d'ondes située entre 770 et 795 nanomètres. L'imprimante et son système laser sont conçus pour impossible, dans des conditions normales d'utilisation, d'entretien par l'utilisateur ou de révision, l'exposition à des rayonnements laser supérieurs à des rayonnements de Classe I.

Avvertenze sui prodotti laser

Questa stampante è certificata negli Stati Uniti per essere conforme ai requisiti del DHHS 21 CFR Sottocapitolo J per i prodotti laser di classe 1 ed è certificata negli altri Paesi come prodotto laser di classe 1 conforme ai requisiti della norma CEI 60825-1.

I prodotti laser di classe non sono considerati pericolosi. La stampante contiene al suo interno un laser di Classe IIIb (3b) che è un laser all'arsenito gallio a 5 milliwatt di alluminio funzionante nell'intervallo di lunghezza d'onda di 770-795 nanometri. Il sistema laser e la stampante sono stati progettati in modo tale che le persone a contatto con la stampante, durante il normale funzionamento, le operazioni di servizio o quelle di assistenza tecnica, non ricevano radiazioni laser superiori al livello della classe 1.

Avisos sobre el láser

Se certifica que, en los EE.UU., esta impresora cumple los requisitos para los productos láser de Clase I (1) establecidos en el subcapítulo J de la norma CFR 21 del DHHS (Departamento de Sanidad y Servicios) y, en los demás países, reúne todas las condiciones expuestas en la norma IEC 60825-1 para productos láser de Clase I (1).

Los productos láser de Clase I no se consideran peligrosos. La impresora contiene en su interior un láser de la clase IIIb (3b) que se trata de un láser de arseniuro de galio con 5 milivatios de aluminio que funciona en el intervalo de longitud de onda entre 770 y 795 nanómetros. El sistema láser y la impresora están diseñados de forma que ninguna persona pueda verse afectada por ningún tipo de radiación láser superior al nivel de la Clase I durante su uso normal, el mantenimiento realizado por el usuario o cualquier otra situación de servicio técnico.

Declaração sobre laser

A impressora está certificada nos E.U.A. em conformidade com os requisitos da regulamentação DHHS 21 CFR Subcapítulo J para a Classe I (1) de produtos laser. Em outros locais, está certificada como um produto laser da Classe I, em conformidade com os requisitos da norma IEC 60825-1.

Os produtos laser da Classe I não são considerados perigosos. A impressora contém no seu interior um laser Classe IIIb (3b) que é nominalmente um laser de 5 miliwatts de alumínio de arseneto de gálio a operar na região de comprimento de onda de 770-795 nanómetros. O sistema e a impressora laser foram concebidos de forma a nunca existir qualquer possibilidade de acesso humano a radiação laser superior a um nível de Classe I durante a operação normal, a manutenção feita pelo utilizador ou condições de assistência prescritas.

Laserinformatie

De printer voldoet aan de eisen die gesteld worden aan een laserprodukt van klasse I. Voor de Verenigde Staten zijn deze eisen vastgelegd in DHHS 21 CFR Subchapter J, voor andere landen in IEC 60825-1.

Laserprodukten van klasse I worden niet als ongevaarlijk aangemerkt. De printer bevat een interne 5 aluminium milliwatt gallium arsenide laser van Klasse IIIb (3b) die werkt in de golflengte 770-795 nanometer. Het lasergeedeelte en de printer zijn zo ontworpen dat bij normaal gebruik, bij onderhoud of reparatie conform de voorschriften, nooit blootstelling mogelijk is aan laserstraling boven een niveau zoals voorgeschreven is voor klasse 1.

Lasermeddelelse

Printeren er godkendt som et Klasse I-laserprodukt, i overensstemmelse med kravene i IEC 60825-1.

Klasse I-laserprodukter betragtes ikke som farlige. Printeren indeholder en Class IIIB (3b)-laser, der nominelt er en 5 aluminium milliwatt gallium arsenid-laser, som arbejder i et bølgelængdeområde af 770-795 nanometer. Lasersystemet og printeren er udformet således, at mennesker aldrig udsættes for en laserstråling over Klasse I-niveau ved normal drift, brugervedligeholdelse eller obligatoriske servicebetjninger.

Huomautus laserlaitteesta

Tämä kirjoitin on Yhdysvalloissa luokan I (1) laserlaitteiden DHHS 21 CFR Subchapter J -määrityksen mukainen ja muualla luokan I laserlaitteiden IEC 60825-1 -määrityksen mukainen.

Luokan I laserlaitteiden ei katsota olevan vaarallisia käyttäjälle. Tulostin sisältää luokan IIIB (3b) alumiinigalliumarsenidilaserin, joka toimii 5 milliwatin nimellisteholla ja 770 - 795 nanometrin aallonpituusalueella. Laserjärjestelmä ja kirjoitin on suunniteltu siten, että käyttäjä ei altistu luokan I määräyksiä voimakkaammalle säteilylle kirjoittimen normaalin toiminnan, käyttäjän tekemien huoltotoimien tai muiden huoltotoimien yhteydessä.

LUOKAN I LASERLAITE

VAROITUS! Laitteen käyttäminen muulla kuin tässä käyttöohjeessa mainitulla tavalla saattaa altistaa käyttäjän turvallisuusluokan I ylittävälle näkyvämmälle lasersäteilylle.

KLASS 1 LASER APPARAT

WARNING! Om apparaten används på annat sätt än i denna bruksanvisning specificerats, kan användaren utsättas för osynlig laserstrålning, som överskrider gränsen för laserklass 1.

Laser-notis

Denna skrivare är i USA certifierad att motsvara kraven i DHHS 21 CFR, underparagraf J för laserprodukter av Klass I (1). I andra länder uppfyller skrivaren kraven för laserprodukter av Klass I enligt kraven i IEC 60825-1.

Laserprodukter i Klass I anses ej hälsovådliga. Skrivaren innehåller en inbyggd 5 milliwatts galliumarsenidlaser av klass IIIB (3b), som arbetar med våglängder i intervallet 770-795 nanometer. Lasersystemet och skrivaren är utformade så att det aldrig finns risk för att någon person utsätts för laserstrålning över Klass I-nivå vid normal användning, underhåll som utförs av användaren eller annan föreskriven serviceåtgärd.

Laser-melding

Skriveren er godkjent i USA etter kravene i DHHS 21 CFR, underkapittel J, for klasse I (1) laserprodukter, og er i andre land godkjent som et Klasse I-laserprodukt i samsvar med kravene i IEC 60825-1.

Klasse I-laserprodukter er ikke å betrakte som farlige. Skriveren har en innebygd laser i klasse IIIB (3b) som nominelt er en 5 milliwatts galliumaluminiumarsenidlaser som opererer med bølgelengder i området 770-795 nanometer. Lasersystemet og skriveren er utformet slik at personer aldri utsettes for laserstråling ut over klasse I-nivå under vanlig bruk, vedlikehold som utføres av brukeren, eller foreskrevne serviceoperasjoner.

Avís sobre el làser

Segons ha estat certificat als Estats Units, aquesta impressora compleix els requisits de DHHS 21 CFR, apartat J, pels productes làser de classe I (1), i segons ha estat certificat en altres llocs, és un producte làser de classe I que compleix els requisits d'IEC 60825-1.

Els productes làser de classe I no es consideren perillosos. La impressora conté internament un làser de la classe IIIb (3b) que nominalment es tracta d'un làser d'arsenur de gal·li amb 5 milivats d'alumini que funciona a l'interval de longitud d'ona entre 770 i 795 nanòmetres. El sistema làser i la impressora han sigut concebut de manera que mai hi hagi exposició a la radiació làser per sobre d'un nivell de classe I durant una operació normal, durant les tasques de manteniment d'usuari ni durant els serveis que satisfacin les condicions prescrites.

Chinese Laser Notice

注意:

本打印机被美国认证合乎 DHHS 21 CFR Subchapter J 对分类 I (1) 激光产品的标准, 而在其他地区则被认证合乎 IEC 60825-1 的标准。

一般认为分类 I 激光产品不具有危险性, 本打印机内部含有分类 IIIb (3b) 的激光, 在操作过程中会产生 5 毫瓦含镓铝砷的微量激光, 其波长范围在 770-795 nm 之间。本激光系统及打印机的设计, 在一般操作、使用者维护或规定内的维修情况下, 不会使人体接触分类 I 以上等级的辐射。



Safety Information

Safety Information

- If your product is NOT marked with this symbol , it MUST be connected to an electrical outlet that is properly grounded.
- The power cord must be connected to an electrical outlet that is near the product and easily accessible.
- Refer service or repairs, other than those described in the operating instructions, to a professional service person.
- This product is designed, tested and approved to meet strict global safety standards with the use of specific Lexmark components. The safety features of some parts may not always be obvious. Lexmark is not responsible for the use of other replacement parts.
- Your product uses a laser, exercise **CAUTION: Use of controls or adjustments or performance of procedures other than those specified herein may result in hazardous radiation exposure.**
- Your product uses a printing process that heats the print media, and the heat may cause the media to release emissions. You must understand the section in your operating instructions that discusses the guidelines for selecting print media to avoid the possibility of harmful emissions.

Consignes de sécurité

- Si le symbole  n'apparaît PAS sur votre produit, ce dernier DOIT être branché sur une prise de courant mise à la terre.
- Le câble d'alimentation doit être connecté à une prise de courant placée près du produit et facilement accessible.
- L'entretien et les réparations autres que ceux décrits dans les instructions d'emploi doivent être effectués par le personnel de maintenance qualifié.
- Ce produit a été conçu, testé et approuvé pour respecter les normes strictes de sécurité globale lors de l'utilisation de composants Lexmark spécifiques. Les caractéristiques de sécurité de certains éléments ne sont pas toujours évidentes. Lexmark ne peut être tenu responsable de l'utilisation d'autres pièces de rechange.
- Le produit utilise un laser :
ATTENTION : Les commandes, les réglages et l'exécution de toute autre procédure que celle indiquée dans le présent document peuvent entraîner des risques de radiations.
- Le produit utilise un système d'impression qui chauffe le support d'impression duquel peuvent alors se dégager des émissions. Vous devez consulter les directives générales dans la section appropriée des instructions d'emploi pour savoir comment empêcher que ces émissions ne se produisent.

Norme di sicurezza

- Se il prodotto NON è contrassegnato con questo simbolo  DEVE essere collegato lo stesso ad una presa elettrica con messa a terra.
- Il cavo di alimentazione deve essere collegato ad una presa elettrica posta nelle vicinanze del prodotto e facilmente raggiungibile.
- Per la manutenzione o le riparazioni, escluse quelle descritte nelle istruzioni operative, consultare il personale di assistenza autorizzato.
- Il prodotto è stato progettato, testato e approvato in conformità a severi standard di sicurezza e per l'utilizzo con componenti Lexmark specifici. Le caratteristiche di sicurezza di alcune parti non sempre sono di immediata comprensione. Lexmark non è responsabile per l'utilizzo di parti di ricambio di altri produttori.
- Poiché il prodotto in questione utilizza il laser, considerare il seguente avvertimento:
ATTENZIONE: L'uso di dispositivi di controllo o di regolazione, o l'esecuzione di procedure non incluse tra quelle descritte in questa documentazione, può provocare una pericolosa esposizione alle radiazioni.
- Il prodotto in questione utilizza un processo di stampa che riscalda i supporti di stampa; il calore generato può determinare l'emissione di sostanze dannose da parte dei supporti. Leggere attentamente la sezione riportata nelle istruzioni riguardante le operazioni di selezione dei supporti di stampa in modo da evitare la possibilità di emissioni dannose.

Sicherheitshinweise

- Falls der Drucker nicht mit diesem Symbol  markiert ist, muß er an eine ordnungsgemäß geerdete Steckdose angeschlossen werden.
- Das Netzkabel muß an eine Steckdose angeschlossen werden, die sich in der Nähe des Geräts befindet und leicht zugänglich ist.
- Wartungsarbeiten und Reparaturen, mit Ausnahme der in der Betriebsanleitung näher beschriebenen, sollten Fachleuten überlassen werden.
- Dieses Produkt und die zugehörigen Komponenten wurden entworfen und getestet, um beim Einsatz die weltweit gültigen Sicherheitsanforderungen zu erfüllen. Die sicherheitsrelevanten Funktionen der Bauteile und Optionen sind nicht immer offensichtlich. Sofern Teile eingesetzt werden, die nicht von Lexmark sind, wird von Lexmark keinerlei Verantwortung oder Haftung für dieses Produkt übernommen.
- Dieses Produkt verwendet einen Laser. Wenden Sie daher besondere **VORSICHT an: Die Verwendung von Kontrollen bzw. die Regulierung von Vorgängen mit Ausnahme derjenigen, die in dieser Betriebsanleitung behandelt werden, kann Sie gefährlicher Bestrahlung aussetzen.**
- Dieses Produkt verwendet ein Druckverfahren, bei dem das Druckmedium erhitzt wird. Diese Erwärmung kann zu einer Freigabe von Emissionen des Druckmediums führen. Es ist daher wichtig, daß Sie in der Betriebsanleitung den Abschnitt, der sich mit der Auswahl geeigneter Druckmedien befaßt, sorgfältig durchlesen und die dort aufgeführten Richtlinien befolgen, um der Gefahr schädlicher Emissionen vorzubeugen.

Pautas de Seguridad

- Si su producto NO tiene este símbolo, , es IMPRESCINDIBLE conectarlo a una toma de corriente eléctrica con toma de tierra correcta.
- El cable de alimentación deberá conectarse a una toma de corriente situada cerca del producto y de fácil acceso.
- Cualquier servicio o reparación deberá realizarse por parte del personal cualificado, a menos que se trate de las averías descritas en las instrucciones de utilización.
- Este producto se ha diseñado, verificado y aprobado para cumplir los más estrictos estándares de seguridad global usando los componentes específicos de Lexmark. Puede que las características de seguridad de algunas piezas no sean siempre evidentes. Lexmark no se hace responsable del uso de otras piezas de recambio.
- El producto utiliza un láser. Actúe con **PRECAUCION: El uso de los controles o ajustes o el llevar a cabo procedimientos distintos a los especificados aquí puede causar niveles de radiación peligrosos.**
- Durante el proceso de impresión que utiliza este producto se calienta el medio de impresión, y el calor puede provocar que el medio emita gases. Para evitar emisiones peligrosas, el usuario deberá comprender y seguir lo expuesto en la sección de las instrucciones de utilización donde se describen las directrices para seleccionar el medio de impresión.

Veiligheidsvoorschriften

- Zorg ervoor dat uw produkt is aangesloten op een geaard stopcontact als het produkt NIET is gemarkeerd met het symbool .
- Het netsnoer moet worden aangesloten op een gemakkelijk bereikbaar stopcontact in de buurt van het produkt.
- Neem contact op met een professionele onderhoudstechnicus voor onderhoud en reparaties die niet in de bij het produkt geleverde instructies beschreven worden.
- Dit product is ontworpen, getest en goedgekeurd om te voldoen aan strenge internationale veiligheidsvoorschriften. De veiligheidsvoorzieningen van bepaalde onderdelen zullen niet altijd duidelijk zichtbaar zijn. Lexmark is niet verantwoordelijk voor het gebruik van andere vervangende onderdelen.
- Uw produkt maakt gebruik van een laser, wees **VOORZICHTIG: Instellen van het controlepaneel of, aanpassingen of uitvoering van procedures op andere wijze dan hier is gespecificeerd kunnen leiden tot blootstelling aan gevaarlijke straling.**
- Uw produkt gebruikt een afdrukproces waarbij het afdrukmateriaal verhit raakt. Hierdoor kan straling vrijkomen. Lees het gedeelte in de bij het produkt geleverde instructies, waarin richtlijnen voor de keuze van afdrukmateriaal worden beschreven, zorgvuldig door, zodat u mogelijke schadelijke straling kunt voorkomen.

Sikkerhedsoplysninger

- Hvis dit produkt IKKE er markeret med dette symbol , SKAL det sluttes til en stikkontakt med jordforbindelse.
- Ledningen skal sluttes til en stikkontakt, der er tæt på produktet og som er let tilgængelig.
- Service og reparationer, som ikke er beskrevet i brugsanvisningen, skal udføres af en kvalificeret tekniker.
- Dette produkt er udviklet, testet og godkendt i overensstemmelse med Lexmarks verdensomspændende standarder for sikkerhed. Delenes sikkerhedsfunktioner kan være skjulte. Lexmark påtager sig intet ansvar for brugen af uoriginale reservedele.
- Dit produkt bruger en laser og du skal være **FORSIGTIG: Brug af styremekanismer, indstillinger eller fremgangsmåder, som ikke er beskrevet her, kan resultere i farlig radioaktiv bestråling.**
- Produktet benytter en udskrivningsproces, der opvarmer skrivemediet og denne varme kan føre til at udskriftmedier afgiver dampe. Det er vigtigt at du forstår den del af brugsanvisningen, der omhandler valg af udskriftsmedium, så du kan undgå farlige dampe.

Sikkerhetsinformasjon

- Hvis produktet ditt ikke er merket med dette symbolet, , må det bare kobles til en stikkontakt som er jordet.
- Ledningen må være koblet til en stikkontakt nær produktet. Stikkontakten må være lett tilgjengelig.
- La bare kvalifisert personale ta seg av service og reparasjon som ikke er direkte beskrevet i bruksanvisningen.
- Dette produktet er utviklet, testet og godkjent i overensstemmelse med strenge verdensomspennende sikkerhetsstandarder for bestemte Lexmark-deler. Delenes sikkerhetsfunksjoner kan være skjulte. Lexmark er ikke ansvarlig for bruk av uoriginale reservedeler.
- Produktet ditt bruker en laser.
ADVARSEL: Bruk av styremekanismer, innstillinger eller fremgangsmåter som ikke er beskrevet her, kan resultere i farlig utstråling.
- Produktet ditt bruker en utskriftsprosess som varmer opp skrivemediet, og varmen kan føre til utslipp. Forsikre deg om at du forstår den delen av bruksanvisningen som omhandler valg av utskriftsmedium, slik at du kan unngå farlige utslipp.

Säkerhetsanvisningar

- Om produkten INTE är märkt med denna symbol , MÅSTE den anslutas till ett jordat vägguttag.
- Nätkabeln måste anslutas till ett lättåtkomligt vägguttag i närheten av maskinen.
- Låt endast utbildad servicepersonal utföra sådan service och sådana reparationer som inte beskrivs i handledningen.
- Denna produkt är utformad, testad och godkänd för att uppfylla internationella säkerhetsbestämmelser när den används tillsammans med andra Lexmark-produkter. Säkerhetsegenskaperna för vissa delar är inte helt uppenbara. Lexmark fransäger sig ansvaret om delar av ett annat fabrikat används.
- Var försiktig - maskinen använder laser.
WARNING! Det finns risk att du utsätter dig för hälsovadlig strålning om du använder andra reglage eller justeringar, eller om du utför andra procedurer än de som beskrivs här.
- Maskinen använder en utskriftsmetod som upphettar utskriftsmaterialet. Het-tan kan i vissa fall leda till att materialet avger partiklar. Undvik skadliga partiklar genom att noga läsa det avsnitt i handledningen som beskriver hur man väljer utskriftsmaterial.

Informació de Seguretat

- Si el vostre producte NO està marcat amb el símbol  , S'HAURÀ de connectar a una presa elèctrica de terra.
- El cable de potència s'haurà de connectar a una presa de corrent propera al producte i fàcilment accessible.
- Si heu de fer una reparació que no figuri entre les descrites a les instruccions de funcionament, confieu-la a un professional.
- Aquest producte està dissenyat, comprovat i aprovat per tal d'acomplir les estrictes normes de seguretat globals amb la utilització de components específics de Lexmark. Les característiques de seguretat d'algunes peces pot ser que no sempre siguin òbvies. Lexmark no es responsabilitza de l'ús d'altres peces de recanvi.
- El vostre producte funciona amb un làser. Procediu amb **PRECAUCIÓ: La utilització de controls, els ajustaments o la realització de procediments distints dels especificats aquí poden donar lloc a una exposició a radiacions perillosa.**
- El vostre producte fa servir un procediment d'impressió que escalfa el mitjà d'impressió, i la calor pot fer que aquest mitjà alliberi emissions. Llegiu atentament l'apartat de les instruccions de funcionament on s'exposen les directrius de selecció del mitjà d'emissió per tal d'evitar la possibilitat d'emissions nocives.

Turvaohjeet

- Jos tuotteessa ei ole tätä tunnusta,  , sen saa kytkeä vain maadoitettuun pistorasiaan.
- Tuotteen verkkojohto on kytkettävä sitä lähellä olevaan pistorasiaan. Varmista, että kulku pistorasian luo on esteetön.
- Muut kuin käyttöohjeissa mainitut huolto- tai korjaustoimet on jätettävä huoltoedustajalle.
- Tämä tuote on testattu ja hyväksytty. Se täyttää korkeat maailmanlaajuiset turvallisuusvaatimukset, kun siinä käytetään tiettyjä Lexmarkin valmistusosia. Joidenkin osien turvallisuusominaisuudet eivät aina ole itsestään selviä. Lexmark ei vastaa muiden kuin alkuperäisten osien käytöstä.
- Laite sisältää lasertuotteen.
Varoitus: Muiden kuin tässä mainittujen säätöjen tai toimien teko voi saattaa käyttäjän alttiiksi vaaralliselle säteilylle.
- Tulostusmateriaali kuumenee tulostusprosessin aikana. Lämmön vaikutuksesta materiaalista saattaa irrota haitallisia aineita. Voit välttää haitalliset päästöt noudattamalla käyttöohjeissa annettuja tulostusmateriaalin valintaohteja.

Informações de Segurança

- Se o produto NÃO estiver marcado com este símbolo, , é necessário ligá-lo a uma tomada com ligação à terra.
- O cabo deve ser ligado a uma tomada localizada perto do produto e facilmente acessível.
- Para todos os serviços ou reparações não referidos nas instruções de operação, deve contactar um técnico dos serviços de assistência.
- Este produto foi concebido, testado e aprovado para satisfazer os padrões globais de segurança na utilização de componentes específicos da Lexmark. As funções de segurança de alguns dos componentes podem não ser sempre óbvias. A Lexmark não é responsável pela utilização de outros componentes de substituição.
- O produto utiliza raios laser, tome **CUIDADO: O uso de controlos, ajustamentos ou a execução de procedimentos diferentes dos especificados podem ocasionar exposição perigosa a radiações.**
- O produto utiliza um processo de impressão que aquece os materiais de impressão. Devido ao aquecimento, estes podem libertar emissões radioactivas. É necessário compreender as instruções de operação relativas à escolha dos materiais de impressão a fim de evitar emissões perigosas.

Informações de Segurança

- Se o produto NÃO estiver marcado com este símbolo, , ele DEVE SER conectado a uma tomada elétrica com ligação à terra.
- O cabo de alimentação deve ser conectado a uma tomada elétrica localizada perto do produto e de fácil acesso.
- Para todos os serviços ou reparações não descritos nas instruções de operação, entre em contato com um técnico dos serviços de assistência.
- Este produto está projetado, testado e aprovado para satisfazer os padrões globais de segurança para uso de componentes específicos da Lexmark. Os recursos de segurança de alguns componentes podem não ser sempre óbvios. A Lexmark não é responsável pelo uso de outros componentes de substituição.
- O produto usa raios laser, tome **CUIDADO: O uso de controlos, ajustes ou a execução de procedimentos diferentes dos especificados podem resultar em exposição perigosa a radiações.**
- O produto usa um processo de impressão que aquece o meio de impressão. Devido ao aquecimento, o meio pode liberar emissões. É necessário que você entenda as instruções de operação sobre a escolha do meio de impressão, para evitar emissões perigosas.

Информация по технике безопасности

- Если приобретенное Вами изделие НЕ имеет маркировки , то его НЕОБХОДИМО подключать к надежно заземленной розетке.
- Кабель питания следует подключать к легкодоступной электрической розетке, расположенной вблизи от места установки изделия.
- Операции по обслуживанию и ремонту, за исключением описанных в настоящем Руководстве, должны выполняться специально обученным персоналом.
- Данное изделие спроектировано, испытано и прошло аттестацию на соответствии жестким глобальным стандартам безопасности в расчете на использование определенных частей производства фирмы Lexmark. Влияние отдельных деталей на безопасность не всегда очевидно. Фирма Lexmark не несет ответственности за использование запасных частей, отличных от рекомендованных.
- Если в изделии используется лазер:
ОСТОРОЖНО! Регулировка или выполнение любых других операций, кроме указанных в настоящем документе, могут привести к опасному воздействию излучения.
- При печати на приобретенном Вами изделии происходит нагрев бумаги, что может привести к выделению из нее паров. Чтобы избежать воздействия вредных веществ, изучите раздел руководства по эксплуатации, в котором обсуждается вопрос выбора бумаги.

Przepisy bezpieczeństwa

Jeżeli produkt NIE jest oznaczony symbolem , może być podłączony TYLKO do prawidłowo uziemionego gniazda elektrycznego.

Kabel zasilający musi być podłączony do łatwo dostępnego gniazda elektrycznego, znajdującego się w pobliżu urządzenia.

Wszelkie naprawy i czynności serwisowe, oprócz opisanych w instrukcji obsługi, powinny być wykonywane przez autoryzowany serwis.

Produkt został zaprojektowany z wykorzystaniem określonych podzespołów firmy Lexmark i zatwierdzony jako spełniający światowe standardy bezpieczeństwa. Pozostałe podzespoły mogą nie spełniać tych warunków. Firma Lexmark nie ponosi odpowiedzialności za skutki używania innych części zamiennych.

Produkt wykorzystuje laser:

UWAGA: Regulowanie, ustawianie i wykonywanie czynności innych niż tu określone, może narazić na ryzyko szkodliwego napromieniowania.

Proces drukowania związany jest z podgrzewaniem nośnika, co może spowodować emisję związków chemicznych. Aby zmniejszyć ryzyko emisji szkodliwych substancji, należy zapoznać się ze wskazówkami dotyczącymi wyboru nośnika, zawartymi w odpowiednim rozdziale instrukcji użytkownika.

Güvenlik Bilgisi

- Ürünüzde  simgesi YOKSA, ürün doğru biçimde topraklanmış bir elektrik prizine TAKILMALIDIR.
- Güç kablosu, ürünün yakınında ve kolay ulaşılabilir bir elektrik prizine takılmalıdır.
- İşletim yönergelerinde açıklananlar dışında servis veya onarım için yetkili servis personeline başvurun.
- Bu ürün, özel Lexmark bileşenlerinin kullanımı konusundaki genel güvenlik standartlarına uyacak biçimde tasarlanmış, denenmiş ve onaylanmıştır. Bazı parçaların güvenlik özellikleri her zaman kesin olmaz. Lexmark, başka yedek parçaların kullanımından sorumluluk taşımaz.
- Ürününüz lazer kullanmaktadır,
DİKKAT: Burada belirtilenler dışında denetimler veya ayarlamalar veya yordam uygulamaları yaptığınız takdirde, beklenmedik radyasyon yayılımına yol açabilirsiniz.
- Ürününüz, üzerine baskı yaptığınız malzemeyi ısıtan bir yazdırma süreci kullanmaktadır ve ısı, üzerine baskı yaptığınız malzemenin emisyonu bırakmasına neden olababilir. İşletim yönergelerinizde, zararlı emisyon olanağını engellemek üzere üzerine baskı yapılacak malzemeyi seçme konusundaki ana hatları içeren bölümü dikkatli biçimde okuyunuz.

安全信息

- 如果您的产品没有  符号，所接的电源插座必须要有适当的接地处理。
- 电源线所连接的电源插座与产品的距离不可太远，并且要符合使用方便的原则。
- 有关维护或修理方面的细节，除了参考操作说明书以外，还可以与专业服务人员联系。
- 本产品使用特定的 Lexmark 元件，并按照严格的世界安全标准来设计、测试及验证。有些零件的安全功能特征可能不一定很明显，对于更换其他厂家零件所造成的不良后果，Lexmark 概不负责。
- 本产品使用了激光装置：
请注意：使用本文件未曾提到的控制、调整或操作方式，可能会产生带有危险性的辐射。
- 本产品打印过程中会使打印介质的温度上升，而温度上升可能会导致打印介质产生释放物，请阅读并理解操作说明书中有关正确选择打印介质的章节，以避免产生有害释放物。



Warranty

Statement of Limited Warranty

Lexmark International, Inc., Lexington, KY

This warranty applies to the United States and Canada. For customers outside the U.S. and Canada, refer to the country-specific warranty information that came with your printer.

Lexmark Optra M410 and M412 Laser Printers

This Statement of Limited Warranty applies to this product if it was originally purchased for your use, and not for resale, from Lexmark or a Lexmark remarketer, referred to in this statement as "Remarketer."

Warranty

Lexmark warrants that this product:

- Is manufactured from new parts, or new and serviceable used parts, which perform like new parts,
- Is free from defects in material and workmanship,
- Conforms to Lexmark's official published specifications, and
- Is in good working order.

If this product does not function as warranted during the warranty period, contact a Remarketer or Lexmark for repair without charge.

If this product is a feature or option, this statement applies only when that feature or option is used with the product for which it was designed. To obtain warranty service, you may be required to present the feature or option with the product.

If you transfer this product to another user, warranty service under the terms of this statement is available to that user for the remainder of the warranty period. You should transfer proof of original purchase and this statement to that user.

Warranty Service

The warranty period is 12 months and starts on the date of original purchase as shown on the purchase receipt.

To obtain warranty service you may be required to present proof of original purchase. Warranty service will be provided at your location, at a Remarketer or a Lexmark designated location. You may be required to deliver your product to the Remarketer or Lexmark, or ship it prepaid and suitably packaged to a Lexmark designated location. You are responsible for loss of, or damage to, a product in transit to the Remarketer or the designated location, at a Lexmark designated location.

- at your location.
- at a Remarketer or a Lexmark designated location. You may be required to deliver your product to the Remarketer or Lexmark, or ship it prepaid and suitably packaged to a Lexmark designated location. You are responsible for loss of, or damage to, a product in transit to the Remarketer or the designated location.
- at a Lexmark designated location.

When warranty service involves the exchange of a product or part, the item replaced becomes the property of the Remarketer or Lexmark. The replacement may be a new or repaired item. The replacement item assumes the remaining warranty period of the original product.

Replacement is not available to you if the product you present for exchange is defaced, altered, in need of a repair not included in warranty service, or damaged beyond repair. Also, such product must be free of any legal obligation or restrictions that prevent its exchange.

Before you present this product for warranty service, remove all programs, data, and removable storage media.

For further explanation of your warranty alternatives and the nearest Lexmark authorized servicer in your area, please contact Lexmark at 1-800-LEXMARK (1-800-539-6275), or on the World Wide Web at <http://www.lexmark.com>.

Free remote technical support is provided for this product throughout its warranty period. Lexmark offers a variety of extended warranty programs that include an extension of technical support. For products no longer covered by a Lexmark warranty, technical support may only be available for a fee.

Extent of Warranty

We do not warrant uninterrupted or error-free operation of a product.

Warranty service does not include repair of failures caused by:

- modification or attachments
- accidents or misuse
- unsuitable physical or operating environment
- maintenance by anyone other than Lexmark or a Lexmark authorized servicer
- operation of a product beyond the limit of its duty cycle
- failure to have installed a maintenance kit as specified (if applicable)
- use of printing media outside of Lexmark specifications
- use of other than Lexmark supplies (such as toner cartridges, inkjet cartridges, and ribbons)
- use of other than Lexmark product or component

ALL EXPRESS AND IMPLIED WARRANTIES, INCLUDING THE IMPLIED WARRANTIES OF MERCHANTABILITY AND FITNESS FOR A PARTICULAR PURPOSE, ARE LIMITED IN DURATION TO THE WARRANTY PERIOD. NO WARRANTIES, EXPRESS OR IMPLIED, WILL APPLY AFTER THIS PERIOD.

Limitation of Liability

Your sole remedy under this Statement of Limited Warranty is set forth in this section. For any claim concerning performance or nonperformance of Lexmark or a Remarketer for this product under this Statement of Limited Warranty, you may recover actual damages up to the limit set forth in the following paragraph.

Lexmark's liability for actual damages from any cause whatsoever will be limited to the greater of 1) \$5,000 or 2) the amount you paid for the product that caused the damages. This limitation of liability will not apply to claims by you for bodily injury or damage to real property or tangible personal property for which Lexmark is legally liable. In no event will Lexmark be liable for any lost profits, lost savings, incidental damage, or other economic consequential damages. This is true even if you advise Lexmark or a Remarketer of the possibility of such damages. Lexmark is not liable for any claim by you based on a third party claim.

This limitation of remedies also applies to any developer of materials supplied to Lexmark. Lexmark's and the developer's limitations of remedies are not cumulative. Such developer is an intended beneficiary of this limitation.

Additional Rights

Some states do not allow limitations on how long an implied warranty lasts, or do not allow the exclusion or limitation of incidental or consequential damages. If such laws apply, the limitations or exclusions contained in this statement may not apply to you.

This warranty gives you specific legal rights. You may also have other rights which vary from state to state.

Glossary

Numerics

7 3/4 Envelope. See *Monarch*.

9 Envelope. An envelope measuring 98.4 x 225.4 mm (3.875 x 8.875 in.).

10 Envelope. See *Com-10*.

500-sheet optional drawer. An optional input tray and drawer you can purchase for the printer to increase input capacity.

1200 Image Quality. A print resolution setting that lets the printer to vary the size of each printed pixel, thereby producing a continuous tone effect. This setting improves the print quality of graphic fills, images, and halftones.

A **A4.** Print material measuring 210 x 297 mm (8.27 x 11.7 in.).

A5. Print material measuring 148 x 210 mm (5.83 x 8.27 in.).

all points addressable (APA). In computer graphics, the ability to address and display, or not display, each picture element (pel) on a display surface.

APA. See *all points addressable*.

application. See *software application*.

attendance message. An operator panel message that describes a printer problem. Operator intervention is required before the printer can continue processing.

automated fax system. A Lexmark system for providing customers with quick product information, technical tips, and printer driver information.

automatic interface. A printer function that determines the active interface: parallel, serial, network, infrared, LocalTalk, or USB.

B **B5.** (1) Envelope measuring 176 x 250 mm (6.93 x 9.84 in.).
(2) Print material measuring 182 x 257 mm
(7.17 x 10.12 in.).

baud. The rate, in bits per second (bps), at which data is transferred to or from the computer through the serial interface.

bidirectional communication. Two-way communication between the printer and a computer, using Network Printing Alliance Protocol (NPAP 1.0 standard).

bin. See *output bin*.

bitmapped font. Predefined pattern of bits that represent a typeface at a specific size, style, and resolution.

bits per second (bps). A measurement of the speed of data transferred through a serial interface.

bps. See *bits per second*.

buffer. A portion of memory used to temporarily store data.

Busy. A printer state in which the printer is processing data or printing pages.

byte. A group of eight binary digits processed as a unit. Typically used to represent an alphanumeric character.

C **C5.** Envelope measuring 162 x 229 mm (6.38 x 9.01 in.).

card stock. Heavy, single-ply print material frequently used for reports or book covers.

Centronics parallel interface. A standard for connecting printers and other peripheral devices to a computer. It defines the plug, socket and electrical signals that are used for controlling the transmission of data.

characters per inch (cpi). The number of characters that can be printed in one inch.

Com-10. Also called a 10 Envelope. An envelope measuring 104.8 x 241.3 mm (4.125 x 9.5 in.).

configuration. (1) The arrangement of a computer system, printer, or network. (2) The devices and programs that make up a system, subsystem, or network.

corona wire. A thin wire in the printer that electrically charges the print material to attract toner from the photoconductor.

curl. Curvature at the edge of a sheet of print material.

D **Data Set Ready (DSR).** A “handshaking” signal contained in a serial interface indicating the device is ready to exchange information.

data stream. Print data and printer control information that flows from the host system (computer) to the printer without interruption.

Data Terminal Ready (DTR). A “handshaking” signal contained in a serial interface indicating the device is ready to exchange information.

default. An attribute, value, or setting that is assumed when none is explicitly specified.

disk. See *hard disk option*.

display. See *operator panel display*.

DL. Envelope measuring 110 x 220 mm (4.33 x 8.66 in.).

download. To transfer information, such as fonts, from a diskette or other device to your computer or printer for temporary or permanent storage.

dpi. Dots per inch. See *resolution*.

DRAM. See *dynamic random access memory*.

driver. See *printer driver*.

DSR. See *Data Set Ready*.

DTR. See *Data Terminal Ready*.

duplex. To print on both sides of a sheet of print material.

dynamic random access memory (DRAM). Memory that allows rapid storage and retrieval of data. DRAM contents are erased when electrical power is turned off.

E emulation. Imitation of a printer processing language. For example, PCL 6 emulation imitates the Hewlett-Packard LaserJet printer language.

ENA. External network adapter. See *external print server*.

error message. See *attendance message*.

Ethernet. A network with a bus topology that utilizes carrier sense multiple access with collision detection (CSMA/CD). An Ethernet network may be installed using any of three cabling systems:

- Ethernet 10Base2 (using RG-58 coax)
- Ethernet 10BaseT (using telephone twisted pair cable)
- Ethernet 100BaseTX

executive. Print material measuring 184.2 x 266.7 mm (7.25 x 10.5 in.).

external network adapter (ENA). See *external print server*.

external print server. Also called an external network adapter (ENA). A LAN device that attaches externally to the printer and lets you connect various printers to your network, thereby freeing dedicated PC print servers for use as LAN workstations.

F **factory default.** Printer setting defined when the printer is manufactured.

Fastbytes protocol. A parallel printer protocol that enables the printer to receive information at faster than normal transmission rates.

fixed-pitch font. A font that prints each character in a fixed amount of horizontal space, regardless of the width of the character. These fonts are identified by the number of characters that print in 1 inch of horizontal line space, such as 10 pitch or 12 pitch.

flash memory. Optional memory you can install in the printer to provide non-volatile storage for downloaded fonts, symbol sets, or macros.

font. A family or set of characters that have common visual characteristics, such as size, weight, and style; for example, Arial Bold.

fuser. The part of the printer that uses heat and pressure to make toner adhere to the print material.

G **grain.** The alignment of the paper fibers in a sheet of print material. For example, in grain long paper, the fibers run the length of the page.

g/m². Grams per square meter. Metric measurement for print material weight.

H **handshaking.** The exchange of predetermined signals when a connection is established.

hard disk option. An optional device you can install in the printer to provide non-volatile storage for downloaded fonts, symbol sets, or macros.

hex trace. A diagnostic printer mode that lets you print the uninterpreted printer data stream so you can see a hexadecimal and character representation of a print job.

Honor INIT. A printer setting that allows the printer to be reset by an initialization signal sent from the computer.

I **images.** Visual data typically scanned from original sources external to the PC, such as photographs or video frames.

INA. Internal network adapter. See *internal print server*.

infrared adapter. An external device that uses a low-power infrared beam to allow a computer to exchange data with a printer without a physical connection between the two.

input source. A printer tray or the multipurpose feeder. An input source holds print material for printing.

Integrated Network Option. See *print server*.

interface. The connection between the computer and the printer.

internal network adapter (INA). See *internal print server*.

internal print server. Also called an internal network adapter (INA). An optional card you can install in the printer to connect it to a local area network (LAN).

J **job accounting.** A printer feature that lets you store statistical information about most recent printer jobs on a hard disk option installed in the printer.

job buffering. A printer feature that lets you spool print jobs to a hard disk option installed in the printer.

K **KB.** Kilobyte; 1024 bytes.

L **LAN.** See *local area network*.

landscape orientation. Printed page orientation in which the width of the page is greater than the height.

LCD. See *liquid crystal display*.

leading edge. The edge of the printed page that exits the printer first.

legal. Print material measuring 215.9 x 356 mm (8.5 x 14 in.).

letter. Print material measuring 215.9 x 279.4 mm (8.5 x 11 in.).

lines per page (lpp). The number of lines of text that can be printed on one page.

link. The connection between the computer system or local area network and the printer.

liquid crystal display (LCD). The display technology that shows operator panel messages and menu selections.

local area network (LAN). A computer network located on a user's premises within a limited geographical area.

long-edge binding. A printer setting that arranges the orientation and layout of a duplexed page to be bound along the long side of the page.

LPTx. A representation of one of the logical parallel ports (for example, LPT1) on a personal computer.

M

macro. A collection of commands grouped together and temporarily or permanently stored in printer memory.

manual feed. A process of feeding print material (paper, envelope, label, transparency, card stock) into the multipurpose feeder on the printer one sheet at a time.

MarkNet S. Family of multi-protocol Lexmark internal print servers. Ethernet and Token-Ring versions are available.

MarkNet XLe. Family of multi-protocol Lexmark external print servers. Ethernet, Token-Ring, and LocalTalk versions are available.

MarkVision. A printer utility that provides continuous printer status and lets you configure multiple printers from a single setup file.

MB. Megabyte; 1,048,576 bytes.

media. See *print material*.

menu. A list of choices that control printer operation, printer features, and the appearance of the printed page.

menu item. See *setting*.

Monarch. Also called a 7 3/4 Envelope. An envelope measuring 98.4 x 190.5 mm (3.875 x 7.5 in.).

monospaced font. A font in which the space for each character does not vary, regardless of the width of the character.

multipurpose feeder. A print material input source on the front of the printer that lets you load a small stack of paper, envelopes, transparencies, labels, and odd-size print material. You can also use the multipurpose feeder to manually feed print material into the printer one sheet at a time.

N **network.** A group of computers, printers, and other hardware devices connected to each other to share information.

network adapter. See *print server*.

non-volatile random access memory (NVRAM). Memory that allows rapid storing and retrieving of data. NVRAM contents are preserved when electrical power is turned off.

Not Ready. A printer state in which the printer does not accept data from the computer. This state is initiated either by operator intervention or a printer error.

O **operating system.** The basic software which provides the low-level functions needed to operate your computer, such as booting up.

Operation ReSource. A Lexmark process established to recycle toner cartridges and print units.

operator panel. The buttons and liquid crystal display (LCD) on the printer that are used to change printer settings and display printer status.

operator panel display. The liquid crystal display on the operator panel that shows printer menus and messages.

operator panel overlay. An adhesive label with translated names for the operator panel display buttons and numbers in one language. A package of overlays is supplied for you to select the label with the language you need.

orientation. A page description defining whether the printed text runs along the short edge (portrait) or the long edge (landscape) of the page.

Other Envelope. Value to select for all envelopes that are not a standard size; defaults to 229.11 x 356 mm (9.02 x 14 in.). Set the actual size of the envelope from your software application.

output bin. A print material exit area. The default is the standard output bin, located on top of the printer. A rear output bin, located on the back of the printer, is also available.

overlay. Background text or graphics that appear consistent in each file that uses the overlay.

P **pages per minute (ppm).** The number of typical pages of text that can be printed in one minute.

paper. See *print material*.

paper guides. The length guide and the width guide located in an input tray that define proper placement of print material. Failing to properly adjust these guides may result in paper jams.

paper type. A printer setting that defines the type of print material (plain paper, card stock, transparency, label, bond, letterhead, preprinted, colored paper, envelope, or custom) loaded in a specified input source.

parallel interface. A bidirectional interface for exchanging data between the computer and the printer.

parallel/USB interface option card. An optional card that connects your printer to a parallel interface and a Universal Serial Bus (USB).

pel. Picture element. The smallest addressable unit that can be effectively reproduced by the printer.

photoconductor. An element of the print unit that works like film in a camera. As the photoconductor drum rotates, it uses positive and negative charges to alternately attract the toner necessary to define the image produced by the laser and transfer the image to the page. Fingerprints or scratches on the photoconductor prevent proper toner transfer and may result in reduced print quality.

pitch. A unit of measure that determines the number of characters that can be printed in 1 horizontal inch. For example, a 10-pitch font prints 10 characters per inch (dpi).

point. A unit of measure that determines the height of a printed character (1 point = 1/72 in.).

point size. The height of the characters in a font.

portrait orientation. Printed page orientation in which the height of the page is greater than the width.

power saver. A printer setting that reduces power usage when the printer is idle. When the **Power Saver** message displays, the printer is ready to receive print jobs.

ppm. See *pages per minute*.

PQET. See *Print Quality Enhancement Technology*.

precharger wire. A wire inside the print unit that electrically charges the photoconductor during the printing process.

Print and Hold job. A print job sent from your software application, stored in printer memory, and accessed at a later time from the **CONFIDENTIAL JOB** menu item or the **HELD JOBS** menu item. A Print and Hold job lets you delay the printing of a job, print it later, ask for additional copies, verify one copy before printing more, and access confidential print jobs by using a Personal Identification Number (PIN).

print cartridge. The replaceable unit inside the printer that contains the photoconductor and toner supply.

print material. Any material you print on, such as paper, card stock, envelopes, labels, and transparencies.

Print Quality Enhancement Technology (PQET). A printer feature that improves the quality of text by smoothing the edges of characters and lines.

print server. A device that lets you connect the printer to a local area network (LAN).

printer driver. A program that translates software application language to printer language so data can be transferred.

printer language. A set of defined commands (such as PCL or PostScript) to which the printer responds.

printer memory. See *dynamic random access memory (DRAM)* or *random access memory (RAM)*.

proportionally spaced font. A font that varies the width of the character to allow uniform spacing around characters.

protocol. A set of rules governing the communication and data transfer between two or more devices.

R **RAM.** See *random access memory*.

random access memory (RAM). Memory that allows rapid storage and retrieval of data. RAM contents are erased when electrical power is turned off.

Ready. A printer state in which the printer can receive, process, and print data.

resolution. A measure of the sharpness of a printed image, expressed in the number of dots per inch (dpi).

S **scalable font.** A font whose characters are stored only as outlines so it is easy to change (or scale) the size of the characters (measured in points).

screen font. A downloadable font that appears the same on the computer screen as it does on a printed page.

serial interface. A way of communicating between computer and printer by transmitting data one bit at a time.

server. A device that allows the sharing of resources, such as printers, on a network.

service message. An operator panel display message that indicates the printer needs service.

setting. Values you choose from printer menus or software applications that control printer operation and the appearance of the printed page.

setup utility. A program provided with the printer that installs printer drivers, tests printer setup, and completes the setup of printer options.

short-edge binding. A printer setting that arranges the orientation and layout of a duplexed page to be bound along the short side of the page.

simplex. See *single-sided printing*.

single-sided printing. Printing on only one side of a sheet of print material (simplex printing).

SmartSwitch. A printer function that automatically switches the printer language to match that of the current print job.

software application. Any program loaded on your computer used to perform a specific task, such as word processing or data compiling.

Standard protocol. A parallel printer protocol where the printer receives information sent from the computer at a normal transmission rate.

status message. A operator panel display message that provides information on the state of the printer.

symbol set. A unique set of alphanumeric characters and symbols that the printer uses to print the requested font. Different symbol sets offer the diverse characters required for different languages or symbol-intense applications.

system board. The printer main circuit board.

T **timeout.** A time interval allotted for certain operations.

Token-Ring. A type of network communication that conforms to IEEE 802.5 standard. The name is derived from its physical ring configuration and the passing of a token from print server to print server.

toner. The material that adheres to the print material to create a printed page.

toner cartridge. See *print cartridge*.

tray linking. A means of increasing input source capacity by feeding print material from one input source until it is empty and then automatically feeding print material from another input source.

Tri-Port interface option card. An optional card you can install inside the printer to add support for LocalTalk, serial, and infrared interfaces.

TrueType fonts. Fonts that use a single font outline for both screen display and printing. You can use TrueType fonts in Windows applications and scale them to any height. They print exactly as they appear on the screen.

type size. A measurement in pitch or points of a graphic character in a font.

type style. The form or shape of the characters in a font.

typeface. The style that defines a group of characters and symbols.

typographic fonts. Fonts whose characters are spaced proportionally on the page according to character width.

U **Universal.** Value to select for all print material excluding envelopes loaded in the multipurpose feeder that is not a standard size; defaults to 215.9 x 356 mm (8.5 x 14 in.). Set the actual size of the page from your software application.

Universal Serial Bus (USB). An industry accepted serial bus for external devices. It replaces all the different types of serial and parallel ports with one standardized plug.

USB. See *Universal Serial Bus*.

user default. Printer setting selected by a user that remains in effect until a new user default is chosen.

V **value.** One of the settings available for a menu item.

W **watermark.** See *overlay*.

weight. The thickness of the typeface line or the thickness of print material.

Index

Numerics

- 250-sheet input tray
 - loading 124
 - removing 124
- 500-sheet drawer
 - installing 223
 - 500-sheet input tray 225
 - printer on top of 225
 - support unit 224
 - support unit parts 224
- 500-sheet input tray
 - loading 124
 - removing 124
- 900-999 service messages 166
- 1200 Image Quality 71

A

- A4 Width (PCL Emul Menu) 81
- acoustics 246
- Advanced Status (Parallel Menu) 86
- Alarm Control (Setup Menu) 77
- alarm, printer 77
- attendance messages 37, 159
 - 34 Short Paper 159
 - 35 Res Save Off Deficient Memory 159
 - 37 Insufficient Collation Area 160
 - 37 Insufficient Defrag Memory 160
 - 37 Insufficient Memory 160
- attendance messages (continued)
 - 38 Memory Full 161
 - 39 Complex Page 161
 - 51 Defective Flash 161
 - 52 Flash Full 162
 - 53 Unformatted Flash 162
 - 54 Network 1 Software Error 163
 - 54 Par 1 ENA Connection Lost 163
 - 54 Ser 1 Fax Connection Lost 163
 - 54 Serial Option 1 Error 163
 - 54 Std Par ENA Connection Lost 163
 - 55 Insufficient Fax Buffer 164
 - 56 Parallel Port 1 Disabled 164
 - 56 Serial Port 1 Disabled 164
 - 56 Std Parallel Port Disabled 164
 - 58 Too Many Flash Options 165
 - 61 Defective Disk 165
 - 62 Disk Full 165
 - 63 Unformatted Disk 165
 - 70 - 79 messages 165
 - 200 Paper Jam Remove Cartridge 165
 - 201 Paper Jam Remove Cartridge 165
 - 202 Paper Jam Open Rear Door 166
 - 203 Paper Jam Short Paper 166
 - 250 Paper Jam Check MP Feeder 166
 - Change <input source> 167
 - Check Tray 2 Connection 168
 - Close Door or Insert Cartridge 168
 - Delete All Jobs. Go/Stop? 168
 - Enter PIN 168
 - Files will be Lost. Go/Stop? 168

- attendance messages (continued)
 - Held Jobs may be lost. Go/Stop? 160
 - Insert Tray 1 169
 - Install Tray 2 or Cancel Job 169
 - Load <input source> 170
 - Load Manual 171
 - No Jobs Found. Retry? 171
 - Open Rear Door 172
 - Operation Failed Faxes on Disk 172
 - Operation Failed Jobs on Disk 172
 - Print Jobs on Disk? Go/Stop? 172
- Auto Continue (Setup Menu) 75
- Auto CR after LF (PCL Emul Menu) 82
- Auto LF after CR (PCL Emul Menu) 82
- automatic tray linking 48, 135

B

- background shading 178
- Baud (Serial Menu) 89
- beeping 77
- bitmapped fonts, definition 234
- black partial page 179
- blank operator panel display 175
- Blank Pages (Finishing Menu) 53
- Buffered Jobs (Config Menu) 106
- Busy, printer state 152
- buttons, operator panel 35

C

- cable
 - parallel, attaching 12
 - power, attaching 20
 - USB, attaching
 - Macintosh 18
 - Windows 2000 14
 - Windows 98 15
- Cancel Job (Job Menu) 60
- canceling print job 60
- Card Stock & Label Guide* x, 116, 118, 120
- card stock guidelines 122

- CD
 - contents x, 24
 - MarkVision 25, 26
 - online documentation x, 24
- changing printer settings
 - operator panel 40
 - software application 33
- characters
 - incorrect 181
 - jagged 179
- charge roll kit, ordering 195
- cleaning printhead lens 195
- closing
 - multipurpose feeder 150
 - rear output bin door 134
 - upper front door 6
- Collation (Finishing Menu) 53
- Confidential Job 60, 108
- CONFIDENTIAL JOB (Job Menu) 60
- confidential jobs
 - delete 60, 63
 - print 60, 62
 - print copies 60, 64
- Config Menu
 - Buffered Jobs 106
 - Exit Config Menu 107
 - Factory Defaults 107
 - NARROW MEDIA 107
 - Panel Menus 106
 - Prt Quality Pgs 106
- Configure MP (Paper Menu) 49
- configuring
 - fax input buffer size 103
 - infrared input buffer size 94
 - LocalTalk input buffer size 97
 - network input buffer size 92
 - parallel input buffer size 85
 - serial input buffer size 88
 - USB input buffer size 100
- conventions used in book ix
- Copies (Finishing Menu) 53
- CUSTOM TYPES (Paper Menu) 49

D

- Data Bits (Serial Menu) 89
- default settings
 - factory 38, 57
 - user 38, 40
- Defragment Flash (Utilities Menu) 58
- dimensions
 - envelope 117
 - paper 117
- disabling
 - fax 200
 - operator panel menus 41
- disk
 - See *hard disk option*
- Display Language (Setup Menu) 76
- display problems
 - blank 175
 - diamonds 175
 - menu settings, no effect 175
 - Menus Disabled 175
- Download Target (Setup Menu) 74
- downloading fonts 241
- drivers, installing 24

E

- electronic emissions notices 243
- enabling operator panel menus 41
- energy conservation 73, 246
- Energy Star 246
- entering menus 35
- envelopes
 - guidelines 119
 - loading 145, 147
 - sizes supported 117
- Exit Config Menu (Config Menu) 107

F

- factory default settings
 - definition 38

- factory default settings (continued)
 - restoring 57, 107
- Factory Defaults
 - Config Menu 107
 - Utilities Menu 57
- fax
 - choosing hardware 197
 - disabling 200
 - installing 198
 - port 197
 - receiving 198
 - resetting 199
 - setup 198
- Fax Baud (Fax Menu) 102
- Fax Buffer (Fax Menu) 103
- Fax Data Bits (Fax Menu) 102
- fax input buffer size, configuring 103
- Fax Menu
 - Fax Baud 102
 - Fax Buffer 103
 - Fax Data Bits 102
 - Fax Paper Size 104
 - Fax Paper Type 105
 - Fax Parity 103
 - Fax Port 102
- Fax Paper Size (Fax Menu) 104
- Fax Paper Type (Fax Menu) 105
- Fax Parity (Fax Menu) 103
- Fax Port (Fax Menu) 102
- Finishing Menu
 - Blank Pages 53
 - Collation 53
 - Copies 53
 - Multipage Border 56
 - Multipage Order 55
 - Multipage Print 54
 - Multipage View 56
 - Separator Sheets 54
 - Separator Source 54
- flash memory option
 - available options 206
 - defragmenting 58
 - formatting 58
 - installing 207
 - printing directory of contents 57

- flash memory option (continued)
 - removing 210
 - setting as download target 74
- Font Name (PCL Emul Menu) 79
- Font Priority (PostScript Menu) 83
- font samples, printing 57, 242
- Font Source (PCL Emul Menu) 79
- fonts
 - bitmapped 234
 - description 231
 - downloadable 241
 - downloading 241
 - pitch 80, 232
 - point size 79, 232
 - printing sample list 57, 242
 - resident 235
 - scalable 234
 - symbol sets, PCL 6 emulation 239
 - weight and style 231
- Format Disk (Utilities Menu) 58
- Format Flash (Utilities Menu) 58

G

- German acoustics statement 246
- glossary 269
- Go button 35
- guidelines
 - avoiding jams 137
 - card stock 122
 - envelopes 119
 - labels 120
 - letterhead 118
 - multipurpose feeder 140
 - online documentation x
 - paper 118
 - printing letterhead 135
 - storing print material 123
 - transparencies 119

H

- hard disk option
 - available options 213
 - formatting 58
 - installing 216
 - job buffering 212
 - printing directory of contents 57
 - removing 219
 - setting as download target 74
- Held Jobs 65
- held jobs 109
 - delete 65, 68
 - print 65, 67
 - print copies 65, 69
- HELD JOBS (Job Menu) 65
- Hex Trace (Utilities Menu) 59
- Honor DSR (Serial Menu) 90
- Honor Init (Parallel Menu) 86

I

- image quality, poor 179
- indicators
 - light, operator panel 34
 - stack height 9, 128
- information, online documents
 - Card Stock & Label Guide* x
 - Technical Reference* x
- infrared
 - adapter 227
 - connecting to printer 227
 - solving problems 181
 - port 227
 - connecting adapter cable 228
- Infrared Buffer (Infrared Menu) 94
- infrared input buffer size, configuring 94
- Infrared Menu
 - Infrared Buffer 94
 - Infrared Port 93
 - Max Baud Rate 95
 - NPA Mode 94
 - PCL SmartSwitch 93

- Infrared Menu (continued)
 - PS SmartSwitch 93
 - Transmit Delay 95
 - Window Size 94
- Infrared Port (Infrared Menu) 93
- input source, wrong 177
- input tray
 - See *tray*
- installing
 - 500-sheet drawer 223
 - best location 223
 - printer on top of 225
 - 500-sheet input tray 225
 - fax 198
 - flash memory option 207
 - hard disk option 216
 - internal print server 216
 - memory option 207
 - operator panel overlay 22
 - option card 216
 - paper bail 11
 - parallel/USB interface option card 216
 - print cartridge 5
 - printer memory option 207
 - printer side cover 220
 - Tri-Port interface option card 216
- Intellifont fonts 234
- internal network adapter
 - See *internal print server*
- internal print server 211
 - installing 216
 - removing 219
- internal print server settings page, printing 57

J

- jagged
 - characters 179
 - edges 72
- Jam Recovery (Setup Menu) 75
- jams, paper
 - See *paper jams*
- Job Accounting (Setup Menu) 78
- Job Acct Limit (Setup Menu) 78

- Job Acct Stat (Utilities Menu) 59
- Job Buffer Size (Setup Menu) 77
- Job Buffering
 - Parallel Menu 85
 - USB Menu 101
- job buffering
 - allocating memory 77
 - parallel port 85
 - USB port 101
- Job Menu
 - Cancel Job 60
 - CONFIDENTIAL JOB 60
 - HELD JOBS 65
 - Print Buffer 70
 - Reset Printer 70
- job not printing 181
- job offset, preventing 11, 177
- job statistics
 - deleting 59
 - printing 59, 78
 - setting maximum number of jobs 78
 - storing on disk 78

L

- labels, guidelines 120
- landscape orientation 80
- language, changing operator panel display 23, 76
- laser notices 247
- LCD
 - See *liquid crystal display*
- length guide, adjusting
 - 250-sheet input tray 7, 125
 - 500-sheet input tray 126
- letterhead
 - guidelines 118
 - loading 146
 - page orientation 135
 - printing 135
- Lines per Page (PCL Emul Menu) 81
- linking trays 135
- liquid crystal display (LCD) 34

- loading
 - envelopes 145, 147
 - letterhead 146
 - multipurpose feeder 130, 143
 - paper 6, 144, 146
 - transparencies 144, 147
 - tray 1 6, 124
 - tray 2 124
- LocalTalk Addr (LocalTalk Menu) 98
- LocalTalk Buffer (LocalTalk Menu) 97
- LocalTalk input buffer size, configuring 97
- LocalTalk Menu
 - LocalTalk Addr 98
 - LocalTalk Buffer 97
 - LocalTalk Name 97
 - LocalTalk Port 96
 - LocalTalk Zone 98
 - NPA Hosts 97
 - NPA Mode 97
 - PCL SmartSwitch 96
 - PS SmartSwitch 96
- LocalTalk Name (LocalTalk Menu) 97
- LocalTalk network 212
- LocalTalk Port (LocalTalk Menu) 96
- LocalTalk Zone (LocalTalk Menu) 98

M

- Macintosh
 - MarkVision 25
- manual duplex printing 136
 - from multipurpose feeder 136
 - from trays 136
- margins, incorrect 179
- MarkTrack 28
- MarkVision
 - changing settings 33
 - online documentation x
 - operating systems supported 25
- MarkVision for Intranets 26
- Max Baud Rate (Infrared Menu) 95
- media guidelines
 - card stock 122
 - envelopes 119

- media guidelines (continued)
 - labels 120
 - letterhead 118
 - paper 118
 - transparencies 119
- media specifications 116
- memory
 - flash memory option 206
 - installing 207
 - printer memory option 206
 - removing 210
- Menu buttons 35
- menu settings page, printing 21, 39, 57, 230
- menus
 - changing settings 40
 - Config 106
 - disabling 41
 - enabling 41
 - entering 35
 - Fax 102
 - Finishing 53
 - Infrared 93
 - Job 59
 - LocalTalk 96
 - Network 91
 - operator panel 38
 - overview 43
 - Paper 44
 - Parallel 84
 - PCL Emul 79
 - PostScript 83
 - Quality 71
 - selecting
 - menu items 36
 - numerical values 35
 - Serial 87
 - settings
 - changing 40
 - printing 21, 39, 57, 230
 - Setup 73
 - USB 99
 - Utilities 57
- messages
 - attendance 37, 159
 - service 37, 166

- messages (continued)
 - status 37, 151
 - warning 37, 158
- Multipage Border (Finishing Menu) 56
- Multipage Order (Finishing Menu) 55
- Multipage Print (Finishing Menu) 54
- Multipage View (Finishing Menu) 56
- multiple page feeds 177
- multipurpose feeder
 - capacity 139
 - closing 150
 - configuring 49
 - feeding one-page jobs 44, 46, 48, 49, 139
 - guidelines 140
 - loading
 - envelopes 145, 147
 - letterhead 146
 - paper 144, 146
 - print material 143
 - transparencies 144, 147
 - media specifications 116
 - opening 141
 - operator panel settings 149

N

- NARROW MEDIA (Config Menu) 107
- Network 1 Setup (Network Menu) 92
- network adapter
 - See *internal print server*
- Network Buffer (Network Menu) 92
- network input buffer size, configuring 92
- Network Menu
 - Network 1 Setup 92
 - Network Buffer 92
 - NPA Mode 91
 - PCL SmartSwitch 91
 - PS SmartSwitch 91
- network printing problems
 - incorrect characters 181
 - job not printing 181
- Not Ready, printer state 154
- NPA Hosts (LocalTalk Menu) 97

- NPA Mode
 - Infrared Menu 94
 - LocalTalk Menu 97
 - Network Menu 91
 - Parallel Menu 85
 - Serial Menu 87
 - USB Menu 100
- numbers, operator panel 36
- numerical values, selecting 35
- n-up print jobs 54

O

- online documentation x, 24
- opening
 - lower front door 141
 - multipurpose feeder door 141
 - rear output bin door 134, 190
 - upper front door 2
- Operation Resource 194
- operator panel
 - attaching overlay 22
 - buttons 34, 35
 - changing display language 23, 76
 - disabling menus 41
 - enabling menus 41
 - LCD 34
 - menu settings
 - changing 40
 - printing 21, 39, 57, 230
 - menus 38, 43
 - messages
 - attendance 37
 - service 37
 - status 37
 - numbers 36
 - printer indicator light 34
 - problems
 - blank 175
 - diamonds 175
 - menu settings, no effect 175
 - Menus Disabled 175
 - operator panel overlay, attaching 22

- option card
 - installing 216
 - removing 219
- option problems
 - operating incorrectly 180, 181
 - quits working 180
- options
 - flash memory 206
 - hard disk 212
 - internal print server 211
 - parallel/USB interface card 215
 - printer memory 206
 - Tri-Port interface option card 212
 - infrared port 227
 - verifying 229
- Optra Forms 30
- ordering supplies
 - charge roll kit 195
 - print cartridge 193
- Orientation (PCL Emul Menu) 80
- OS/2 Warp
 - MarkVision 25
- output bin
 - standard 133
- overlay, operator panel 22

P

- page breaks, unexpected 177
- Page Protect (Setup Menu) 76
- Panel Menus (Config Menu) 106
- paper
 - guidelines x, 118
 - jams
 - avoiding 137
 - recovery 75
 - letterhead 118
 - loading 144, 146
 - selecting
 - length 52
 - size 45
 - texture 50
 - type 47
 - weight 51

- paper (continued)
 - sizes supported 116, 117
 - sources 115, 116
 - storing 123
 - weights 116
- paper bail, installing 11
- paper guide
 - length 125
 - width 126, 144
- paper jams
 - 200 Paper Jam Remove Cartridge 184
 - 201 Paper Jam Remove Cartridge 184
 - 202 Paper Jam Open Rear Door 186
 - 203 Paper Jam Short Paper 190
 - 250 Paper Jam Check MP Feeder 192
 - avoiding 137
 - filling tray 9
 - using metal stop 9
 - recovery 75
 - reprinting jammed pages 75
- PAPER LENGTH (Paper Menu) 52
- Paper Menu
 - Configure MP 49
 - CUSTOM TYPES 49
 - PAPER LENGTH 52
 - PAPER SIZE 45
 - Paper Source 44
 - PAPER TEXTURE 50
 - PAPER TYPE 47
 - PAPER WEIGHT 51
 - Substitute Size 49
- paper path 184
- PAPER SIZE (Paper Menu) 45
- paper size indicators
 - 250-sheet input tray 7
 - 500-sheet input tray 126
 - standard input tray 7
- Paper Source (Paper Menu) 44
- paper sources 115, 116
 - capacity 116
 - loading 124
 - media specifications 116
 - multipurpose feeder 130, 141
 - selecting 44
 - tray 1 6, 124

- paper sources (continued)
 - tray 2 124
- PAPER TEXTURE (Paper Menu) 50
- PAPER TYPE (Paper Menu) 47
- PAPER WEIGHT (Paper Menu) 51
- Parallel Buffer (Parallel Menu) 85
- parallel cable
 - attaching 12
 - part number 12, 176
- parallel input buffer size, configuring 85
- Parallel Menu
 - Advanced Status 86
 - Honor Init 86
 - Job Buffering 85
 - NPA Mode 85
 - Parallel Buffer 85
 - Parallel Mode 1 86
 - Parallel Mode 2 86
 - PCL SmartSwitch 84
 - Protocol 86
 - PS SmartSwitch 84
- Parallel Mode 1 (Parallel Menu) 86
- Parallel Mode 2 (Parallel Menu) 86
- parallel/USB interface option card
 - installing 216
 - removing 219
- Parity (Serial Menu) 90
- part number
 - parallel cable 12, 176
 - print cartridge 193
 - USB cable 176
- partial page, black 179
- password protection, hard disk option 77
- PCL Emul Menu
 - A4 Width 81
 - Auto CR after LF 82
 - Auto LF after CR 82
 - Font Name 79
 - Font Source 79
 - Lines per Page 81
 - Orientation 80
 - Pitch 80
 - Point Size 79
 - Symbol Set 80
 - TRAY RENUMBER 82
- PCL emulation
 - command listing x
 - printer language selection 73
 - resident fonts 235
- PCL SmartSwitch
 - Infrared Menu 93
 - LocalTalk Menu 96
 - Network Menu 91
 - Parallel Menu 84
 - Serial Menu 87
 - USB Menu 99
- personal identification number (PIN) 34, 35, 36
 - entering 111
- PictureGrade (Quality Menu) 72
- PIN
 - See *personal identification number*
- pitch 80
- Pitch (PCL Emul Menu) 80, 232
- point size 79
- Point Size (PCL Emul Menu) 79, 232
- portrait orientation 80
- PostScript 3 emulation
 - printer language selection 73
 - resident fonts 235
- PostScript Menu
 - Font Priority 83
 - Print PS Error 83
- power cable, attaching 20
- Power Saver (Setup Menu) 73
- Power Saver, printer state 154
- PQET (Quality Menu) 72
- print
 - too dark 179
 - too light 178
- Print and Hold jobs 108, 151
 - Confidential Job 108
 - CONFIDENTIAL JOB (Job Menu) 60
 - formatting errors 113
 - HELD JOBS (Job Menu)
 - Repeat Print job 65, 109
 - Reserve Print job 65, 109
 - Verify Print job 66, 110
 - memory requirement 108
- Print Area (Setup Menu) 76
- Print Buffer (Job Menu) 70

- print cartridge
 - installing 5
 - ordering 193
 - part numbers 193
 - removing 2
 - replacing 194
 - storage 194
 - unpacking 2
- Print Directory (Utilities Menu) 57
- Print Fonts (Utilities Menu) 57
- print job, canceling 60
- print material
 - dimensions, multipurpose feeder 139
 - guidelines
 - avoiding jams 137
 - card stock 122
 - envelopes 119
 - labels 120
 - letterhead 118
 - printing 135
 - multipurpose feeder 140
 - online documentation x
 - paper 118
 - storing print material 123
 - transparencies 119
 - loading 124
 - envelopes 145, 147
 - letterhead 146
 - multipurpose feeder 130, 143
 - paper 144, 146
 - transparencies 144, 147
 - tray 1 6, 124
 - tray 2 124
 - selecting
 - length 52
 - size 45
 - texture 50
 - type 47
 - weight 51
 - sizes supported
 - envelopes 117
 - paper 117
 - type, incorrect 177
- Print Menus (Utilities Menu) 57
- Print Net1 Setup (Utilities Menu) 57
- Print PS Error (PostScript Menu) 83
- print quality problems
 - background shading 178
 - incorrect left and top margins 179
 - jagged
 - characters 179
 - edges 72
 - partial page, black 179
 - poor image quality 179
 - print rubs off page 178
 - print too dark 179
 - print too light 178
 - streaks 179
 - toner fog 178
 - toner on back of page 178
 - toner smears 178
 - uneven edges 179
 - white page 178
- Print Resolution (Quality Menu) 71
- print server 205, 211
 - online documentation x
- Print Timeout (Setup Menu) 74
- printable area 76
- printer
 - alarm 77
 - attendance messages
 - See *attendance messages*
 - commands x
 - connecting 12
 - dimensions 2
 - drivers 24
 - indicator light 34
 - maintenance 193
 - menus 43
 - operator panel 34
 - plugging in 20
 - powering on 20
 - problems 173
 - Ready state 156
 - resetting 70
 - service messages
 - See *service messages*
 - side cover, installing 220
 - status 25, 34

- printer (continued)
 - status messages
 - See *status messages*
 - taking offline 35, 36
 - unpacking 1
 - warning messages
 - See *warning messages*
- Printer Language (Setup Menu) 73
- printer memory option 206
 - installing 207
 - removing 210
- printer messages
 - attendance
 - See *attendance messages*
 - service
 - See *service messages*
 - status
 - See *status messages*
 - warning messages
 - See *warning messages*
- printer settings
 - current default 39
 - operator panel 40
 - software application 33
- printer setup
 - clearance dimensions 1
 - installing print cartridge 5
 - items 1
 - loading standard input tray 6
 - removing packaging 2
 - unpacking 1
 - utility 24
- printer states
 - Busy 152
 - Not Ready 154
 - Power Saver 154
 - Ready 156
 - Ready Hex 156
 - Waiting 157
- printhead lens, cleaning 195
- printing
 - contents
 - flash memory option 57
 - hard disk option 57
 - font sample list 57, 242
- printing (continued)
 - internal print server settings page 57
 - job statistics 59, 78
 - letterhead 135
 - manual duplex 136
 - from multipurpose feeder 136
 - from trays 136
 - menu settings page 21, 39, 57, 230
 - items listed 57, 229
 - n-up jobs 54
 - on two sides 136
 - from multipurpose feeder 136
 - from trays 136
 - quality test pages 106
- printing problems
 - See *problem solving*
- problem solving
 - adjusting light/dark print 71
 - attaching serial cable 182
 - avoiding jams 137
 - filling tray 9
 - using metal stop 9
 - blank pages 53
 - canceling print job 60
 - checklist 173
 - clearing operator panel error messages 35
 - collating pages 53
 - deleted data 70
 - disabling menus 41
 - display
 - blank 175
 - diamonds 175
 - menu settings, no effect 175
 - Menus Disabled 175
 - enabling menus 41
 - fax, resetting 199
 - Hex Trace mode 59
 - lost data
 - flash memory option 58
 - hard disk option 58
 - multipurpose feeder 140
 - network printing problems
 - incorrect characters 181
 - job not printing 181
 - obtaining updated drivers and utilities 182

- problem solving (continued)
 - operator panel
 - blank 175
 - diamonds 175
 - menu settings, no effect 175
 - Menus Disabled 175
 - options
 - operating incorrectly 180, 181
 - quits working 180
 - paper jams
 - avoiding 137
 - clearing 183
 - 200 and 201, Remove Cartridge 184
 - 202, Open Rear Door 186
 - 203, Short Paper 190
 - 250, Check MP Feeder 192
 - print quality
 - background shading 178
 - incorrect left and top margins 179
 - jagged
 - characters 179
 - edges 72
 - partial page, black 179
 - poor image quality 179
 - print rubs off page 178
 - print too dark 179
 - print too light 178
 - streaks 179
 - toner fog 178
 - toner on back of page 178
 - toner smears 178
 - uneven edges 179
 - white page 178
 - printed characters, jagged or uneven edges 72
 - printer
 - beeping 77
 - escape codes 182
 - messages 151
 - problems 173
 - settings 33
 - stops 75
 - printing PostScript errors 83
 - printing problems
 - incorrect characters 176
 - incorrect print material type 177
- problem solving (continued)
 - printing problems (continued)
 - job not printing 176
 - job offset 177
 - misfeeds 177
 - multiple feeds 177
 - unexpected page breaks 177
 - USB port 176
 - wrong input source 177
 - reprinting jammed pages 75
 - restoring factory default settings 57, 107
 - stopping printer 36
 - tray linking 48
 - using correct print material 115
 - using separator sheets 54
 - wrong displayed language 76
 - wrong orientation 80
- Protocol (Parallel Menu) 86
- Prt Quality Pgs (Config Menu) 106
- PS SmartSwitch
 - Infrared Menu 93
 - LocalTalk Menu 96
 - Network Menu 91
 - Parallel Menu 84
 - Serial Menu 87
 - USB Menu 99

Q

- Quality Menu
 - PictureGrade 72
 - PQET 72
 - Print Resolution 71
 - Toner Darkness 71
- quality test pages, printing 106

R

- Ready Hex, printer state 156
- Ready, printer state 156
- rear output bin 134

- removing
 - flash memory option 210
 - hard disk option 219
 - internal print server 219
 - option card 219
 - parallel/USB interface option card 219
 - print cartridge 2
 - printer memory option 210
 - side cover 201
 - Tri-Port interface option card 219
- renumbering trays 82
- Repeat Print job 109
- replacing print cartridge 194
- Reserve Print job 109
- Reset Printer (Job Menu) 70
- resetting
 - fax 199
 - printer 70
- resident fonts 235
- resolution
 - changing 71
 - printer 71
- Resource Save (Setup Menu) 73
- restoring factory default settings 57, 107
- Return button 36
- Robust XON (Serial Menu) 88
- RS-232/RS-422 (Serial Menu) 88
- RS-422 Polarity (Serial Menu) 88

S

- safety information 253
- scalable fonts
 - definition 234
 - resident 235
- Select button 36
- selecting
 - menu items 36
 - numerical values 35
- Separator Sheets (Finishing Menu) 54
- Separator Source (Finishing Menu) 54
- Serial Buffer (Serial Menu) 88
- serial input buffer size, configuring 88
- serial interface 212
- Serial Menu
 - Baud 89
 - Data Bits 89
 - Honor DSR 90
 - NPA Mode 87
 - Parity 90
 - PCL SmartSwitch 87
 - PS SmartSwitch 87
 - Robust XON 88
 - RS-232/RS-422 88
 - RS-422 Polarity 88
 - Serial Buffer 88
 - Serial Protocol 88
- Serial Protocol (Serial Menu) 88
- service messages 37
 - 900-999 166
- settings
 - changing operator panel 40
 - changing software application 33
 - printing current default 39
- Setup Menu
 - Alarm Control 77
 - Auto Continue 75
 - Display Language 76
 - Download Target 74
 - Jam Recovery 75
 - Job Accounting 78
 - Job Acct Limit 78
 - Job Buffer Size 77
 - Page Protect 76
 - Power Saver 73
 - Print Area 76
 - Print Timeout 74
 - Printer Language 73
 - Resource Save 73
 - Wait Timeout 74
- side cover
 - reinstalling 220
 - removing 201
- SNMP 28
- software distribution 29
- software installation 29
- Solaris Ready printers 31

- sources of information, online documents
 - Card Stock & Label Guide* x
 - Technical Reference* x
- stack height indicator 9, 128
- stack height limiter 131, 145, 146
- standard output bin 133
- statistics
 - See *job statistics*
- status messages 37, 151
 - Activating Menu Changes 152
 - Busy 152
 - Cancelling Job 152
 - Clearing Job Accounting Stat 152
 - Defragmenting 152
 - Deleting Jobs 153
 - Disabling Menus 153
 - Enabling Menus 153
 - Flushing Buffer 153
 - Formatting Disk 153
 - Formatting Flash 153
 - Invalid Network 1 Code 153
 - line 1 messages 152
 - Menus Disabled 153
 - Network Card Busy 154
 - Not Ready 154
 - Performing Self Test 154
 - Power Saver 154
 - Printing Directory List 155
 - Printing Font List 155
 - Printing Job Accounting Stat 155
 - Printing Menu Settings 155
 - Printing Quality Test Pages 155
 - Program Flash 155
 - Programming Disk 155
 - Queuing and Deleting Jobs 153, 156
 - Queuing Jobs 156
 - Ready 156
 - Ready Hex 156
 - Res Reduced 157
 - Resetting the Printer 157
 - Restoring Factory Defaults 157
 - Waiting 157
 - warning messages 158
- status, printer
 - MarkVision 25

- Stop button 36
- storing
 - print cartridge 194
 - print material 123
- streaks on page 179
- Substitute Size (Paper Menu) 49
- Sun 27
- supplies
 - charge roll kit, ordering 195
 - print cartridge
 - installing 5
 - ordering 193
 - replacing 194
 - storing 194
- support unit
 - installing 224
 - installing 500-sheet input tray 225
- Symbol Set (PCL Emul Menu) 80
- symbol sets, definition 239
- system board
 - accessing 201
 - closing 220

T

- taking printer offline 35, 36
- TCP/IP 29
- Technical Reference* x
- timeouts
 - Print Timeout 74
 - Wait Timeout 74
- toner
 - fog 178
 - on back of page 178
 - smearing 178
- toner cartridge
 - See *print cartridge*
- Toner Darkness (Quality Menu) 71
- trademarks xi
- Transmit Delay (Infrared Menu) 95
- transparencies
 - guidelines 119
 - loading 144, 147

- tray
 - capacity 116
 - linking 48, 135
 - loading tray 1 124
 - loading tray 2 124
 - media specifications 116
 - paper size indicators 7
 - renumbering 82
- TRAY RENUMBER (PCL Emul Menu) 82
- Tri-Port interface option card 212
 - installing 216
 - removing 219
- TrueType fonts 234
- typeface, description 231

U

- uneven edges 72, 179
- UNIX 27
- unpacking
 - print cartridge 2
 - printer 1
- USB Buffer (USB Menu) 100
- USB cable
 - attaching
 - Macintosh 18
 - Windows 2000 14
 - Windows 98 15
 - part number 176
- USB input buffer size, configuring 100
- USB Menu
 - Job Buffering 101
 - NPA Mode 100
 - PCL SmartSwitch 99
 - PS SmartSwitch 99
 - USB Buffer 100
- user default settings
 - changing 40
 - definition 38
 - printing current settings 39
- utilities
 - installing 24
 - MarkVision 25, 26

- Utilities Menu
 - Defragment Flash 58
 - Factory Defaults 57
 - Format Disk 58
 - Format Flash 58
 - Hex Trace 59
 - Job Acct Stat 59
 - Print Directory 57
 - Print Fonts 57
 - Print Menus 57
 - Print Net1 Setup 57

V

- Verify Print job 110
- verifying options 229

W

- Wait Timeout (Setup Menu) 74
- Waiting, printer state 157
- warning messages 158
 - Fax 1 158
 - Infrared 1 158
 - LocalTalk 1 158
 - Network 1 158
 - Parallel 158
 - Parallel 1 158
 - Serial 1 158
 - Tray 1 Missing 158
 - USB 158
 - USB 1 158
- warranty 265
- white page 178
- width guide, adjusting
 - input trays 8, 10, 126, 128
 - multipurpose feeder 130, 132, 144
- Window Size (Infrared Menu) 94
- Windows
 - MarkVision support 25

Free Manuals Download Website

<http://myh66.com>

<http://usermanuals.us>

<http://www.somanuals.com>

<http://www.4manuals.cc>

<http://www.manual-lib.com>

<http://www.404manual.com>

<http://www.luxmanual.com>

<http://aubethermostatmanual.com>

Golf course search by state

<http://golfingnear.com>

Email search by domain

<http://emailbydomain.com>

Auto manuals search

<http://auto.somanuals.com>

TV manuals search

<http://tv.somanuals.com>