

# User Manual - Hipulse

Installation & Maintenance of Hipulse 130kVA Single phase 110V, Single & 1 + N System





*Dear Customer,*

*Please accept our thanks for giving us the privilege to serve you by choosing a Liebert make 'UPS'.*

*If this is your first Liebert UPS, we hope it is the beginning of a long relationship which delivers value to your organisation. If you already own and use a Liebert product, we are doubly honoured by your decision of continuing this relationship.*

*It is our constant endeavor to partner you for the growth and success of your business. This philosophy is reflected in our Mission statement "**To deliver value through Air & Power Quality solutions to achieve customer delight**". Please do give us feedback to help us realize our Mission.*

*Emerson Network Power (India) Private Limited*



Rev. No.	Revision details	Date

## IMPORTANT

This manual contains information concerning the installation, operation and maintenance of the Hipulse Uninterruptible Power System (UPS) for the single module and one plus one Systems.

*All relevant parts of the manual should be read prior to commencing installation.*

The UPS must be commissioned by an engineer approved by the manufacturer (or his agent) before being put into service. Failure to observe this condition will invalidate any implied warranty.

*The Hipulse UPS has been designed for Commercial / Industrial use only.*

*The Hipulse has not been designed for direct use in any life support application.*

If you encounter any problem with the procedures contained in this manual you should seek immediate assistance from Emerson Network Power (India) Pvt. Ltd. Sales Office from whom the equipment was purchased. Alternatively contact the Emerson Network Power (India) Pvt. Ltd Customer Service & Support department at the address shown below:

EMERSON NETWORK POWER (INDIA) PRIVATE LIMITED  
Plot No. C-20, Road No. 19  
Wagle Industrial Estate  
Thane - 400 604, INDIA

Phone : (00 91 22) 25807000  
25828405

Fax : (00 91 22) 25800829  
25828358

Emerson Network Power (India) Private Limited pursues a policy of continual product development and reserves the right to change the equipment without notice.

*@ Copyright 1999 by Emerson Network Power  
Unauthorized reproduction prohibited  
All rights reserved*





## REGISTERED HEAD OFFICE

### Emerson Network Power (India) Private Limited

PLOT NO. C-20, ROAD NO. 19  
WAGLE INDUSTRIAL ESTATE  
THANE – 400 604 MAHARASHTRA, INDIA

TELEPHONE: (00 91 22) 25807000/ 25828405 / 25802388

FAX: (00 91 22) 25800829 / 25828358

#### \*\*\* WEST ZONE \*\*\*

Mumbai	
Address:	B-414, 424, Bhaveshwar Arcade, (opp. Shreyas cinema), LBS Road, Ghatkopar, Mumbai 400 086
Tel:	91-22-2500 2318, 2500 2294, 2500 2437
Fax:	91-22-2500 2415
Pune	
Address:	B/6, Shree Dwarka Co-op. Soc., Hare Krishna Mandir Path, Model Colony, Off. University Road, Pune 411 016
Tel:	91-20-2567 0709, 2567 6975
Fax:	91-20-400 4020
Baroda	
Address:	39 / 2, Arunodaya Soc., Alkapuri, Baroda 390 005
Tel:	91-265-231 4296 / 2330 383
Fax:	91-265-2343937
Nagpur	
Address:	203, Ganga Apts, 13, Giripeth, Nagpur 400 010
Tel:	91-712-540 423
Fax:	91-712-540 423

#### \*\*\* SOUTH ZONE \*\*\*

Bangalore	
Address:	No. 412, Jindal Center, 2nd Flr, 100 Fleet Road, Koramangalam, Opp. Sukhsagar Hotel, Bangalore - 95
Tel:	91-80-51135670 / 5770 / 5870
Fax:	91-80-2558 8546
Chennai	
Address:	OMS Court, No. 1, Nathamuni Street, T., Nagar, Chennai 600 017
Tel:	91-44-2815 1063, 2815 2596, 712 4863, 713 4884, 713 4883
Fax:	91-44-2815 1442
Kochin	
Address:	"Nedumparambil", No. 1419/36, Kattakara Road, Kaloore, Kochin 682 017
Tel:	91-484-2341 985/86
Fax:	91-484-2341 986
Secunderabad	
Address:	1-1-40/1, 2nd floor, Vasavi Towers, S. D. Road, Secunderabad - 500 003
Tel:	91-40-27806774 / 5/ 6
Fax:	91-40-2780 6777





\*\*\* EAST ZONE \*\*\*

<b>Kolkatta</b>	
Address:	Jindal Towers, 21/1A/3, Darga Road, Kolkata - 700 017
Tel:	91-33-2289 0493 / 033 2289 0490
Fax:	91-33-2289 0492
<b>Bhubaneshwar</b>	
Address:	69, Satya Nagar, Bhubaneshwar 751 007
Tel:	91-674-2520 778
Fax:	91-674-2520 778
<b>Jamshedpur</b>	
Address:	Kashi Kunji, Road No. 2, Ground Floor, Contractors Areas, Bistupur, Jamshedpur 831 001
Tel:	91-657-2227 678
Fax:	91-657-2227 678

\*\*\* NORTH ZONE \*\*\*

<b>New Delhi</b>	
Address:	18/14, WEA, Pusa Lane, Karol Bagh; New Delhi 110 005
Tel:	91-11-2582 4206 / 2582 4208 / 2582 4214 / 18
Fax:	91-11-2575 7601
<b>Chandigarh</b>	
Address:	SCO No. 272, Sector 32 -C & D, 1st Floor, Above Punjab and Sind Bank, Chandigarh.
Tel:	0172-5077531
Fax:	0172-5016531
<b>Lucknow</b>	
Address:	213, 2nd Floor, Saran Chambers-II, 5, Park Road, Lucknow - 226 001 (U.P)
Tel:	91-522-2237174
Fax:	91-522-2239877
<b>Guwahati</b>	
Address :	C/o. Ashok Bhasin, South Sarania, Ashram Road, (Near GMC Tax Office), Ulubari, Guwahati - 781 007.
Tel:	91-361-2453270
Fax:	91-361-2453270

(Updated: December 1, 2004)



## *Safety Procedure*

### **WARNING**

*In a domestic environment, this product may cause radio interference in which case the user may be required to take additional measures.*

### **WARNING**

***HIGH EARTH LEAKAGE CURRENT: EARTH CONNECTIONS IS ESSENTIAL BEFORE CONNECTING THE INPUT SUPPLY.***

*This equipment must be earthed in accordance with local electrical codes.*

### **WARNING**

***THIS UPS DOES NOT INCORPORATE AUTOMATIC BACKFEED PROTECTION. A WARNING LABEL MUST BE FITTED TO ALL EXTERNAL PRIMARY POWER ISOLATIONS STATING.***

***INSULATE THE UNINTERRUPTIBLE POWER SYSTEM BEFORE WORKING ON THIS CIRCUIT.***



### GENERAL

*As with other types of high power equipment, dangerous voltages are present within the UPS and battery enclosure. The risk of contact with these is minimised as the live component parts are housed behind a hinged, lockable door. Further internal safety screens make the equipment protected to IP20 standards.*

*No risk exists to any personnel when operating the equipment in the normal manner, following the recommended operating procedures.*

*All equipment maintenance and servicing procedures involve internal access and should be carried out only by trained personnel.*

### BATTERIES

*Battery manufacturers supply details of the necessary precautions to be observed when working on, or in the vicinity of a large bank of battery cells. These precautions should be followed implicitly at all times.*

*Particular attention should be paid to the recommendations concerning local environmental conditions and the provision of protective clothing, first-aid and fire fighting facilities*

### TEST EQUIPMENT

*When the battery is under charge, it is earth-referenced about its mid-point –e.g. if the battery is being charged at 460V the battery extremities will be at +230V and – 230V with respect to neutral (earth). When using mains-powered test equipment such as oscilloscopes in the UPS voltage area, always use a differential mode of operation to disconnect the oscilloscope frame earth.*

### PERSONNEL

*When working inside the UPS (trained personnel only) it is recommended that protection be worn to prevent eye damage, should an electric wire be struck by mishandling or severe electrical fault.*

*Some of the power components are very heavy. If their removal is necessary, ensure that sufficient manpower is available; otherwise use adequate mechanical handling equipment.*

*When working in the general area of the UPS where high voltages are present, a second person should be standing-by to assist and summon help in case of accident.*



I N D E X

<b>1</b>	<b>General Introduction</b> .....	<b>1</b>
<b>1.1</b>	<b>Introduction</b>	<b>1</b>
<b>1.2</b>	<b>Design Concept</b>	<b>1</b>
1.2.1	Hipulse Module Design	1
1.2.2	Bypass Supplies	2
1.2.3	System control Philosophy	3
1.2.4	ECOMODE (for single UPS)	4
1.2.5	UPS Power Switch Configuration	5
1.2.6	Battery circuit breaker	5
1.2.7	Battery temperature compensation	5
1.2.8	System Expansion	5
<b>2</b>	<b>Installation Procedure</b> .....	<b>7</b>
<b>2.1</b>	<b>Introduction</b>	<b>7</b>
<b>2.2</b>	<b>Environmental Considerations</b>	<b>8</b>
2.2.1	UPS location	8
2.2.2	Battery Location	8
<b>2.3</b>	<b>Mechanical Considerations</b>	<b>9</b>
2.3.1	System composition	9
2.3.2	Moving the cabinets	9
2.3.3	Clearances	9
2.3.4	Fixing Magnetic Components	9
2.3.5	Cable entry	9
<b>2.4</b>	<b>Preliminary Checks</b>	<b>10</b>
<b>2.5</b>	<b>Installation Drawings</b>	<b>10</b>
<b>3</b>	<b>Installation (Electrical)</b> .....	<b>13</b>
<b>3.1</b>	<b>Power Cabling</b>	<b>13</b>
3.1.1	System Configuration	13
3.1.2	Cable rating	14
3.1.3	General Notes	14
3.1.4	Cable connections	14
3.1.5	Safety earth	14
3.1.6	Protective Devices	15
3.1.7	Cabling procedure	16
<b>3.2</b>	<b>Control cables</b>	<b>19</b>
3.2.1	Battery Control	19
3.2.2	Auxiliary Terminal Block X3 and X4 at UPS	20
3.2.3	Emergency Stop	21
3.2.4	Back feed Protection	21
<b>4</b>	<b>Operator Control and Display</b> .....	<b>23</b>
<b>4.1</b>	<b>Introduction</b>	<b>23</b>
4.1.1	Operator Control Panel	24
4.1.2	The Menu Options	27





<b>5</b>	<b><i>Operating Instructions</i></b> .....	<b>31</b>
5.1	Introduction	31
5.1.1	General Notes	31
5.1.2	Power switches	31
<b>5.2</b>	<b>Procedure for UPS Startup: without interrupting power to the load</b>	<b>32</b>
<b>5.3</b>	<b>Procedure for UPS Startup: without power initially supplied to the load</b>	<b>34</b>
<b>5.4</b>	<b>Procedure for Switching the UPS into Maintenance Bypass condition from Normal Operation</b>	<b>36</b>
<b>5.5</b>	<b>Procedure for Switching the UPS ON from a Maintenance Power condition</b>	<b>38</b>
<b>5.6</b>	<b>Procedure for completely Powering down the UPS</b>	<b>38</b>
<b>5.7</b>	<b>Procedure for carrying out at Reset after a recognized controlled transfer to Bypass or EPO action</b>	<b>39</b>
<b>5.8</b>	<b>Adding a single module to an existing system</b>	<b>40</b>
<b>5.9</b>	<b>Procedure to completely switch ON/ OFF the UPS at the UPS Display control panel</b>	<b>41</b>
<b>5.10</b>	<b>Procedure to switch ON/ OFF the Inverter at UPS Display control panel</b>	<b>43</b>
<b>5.11</b>	<b>Setting the Battery test</b>	<b>44</b>
<b>5.12</b>	<b>Language selection</b>	<b>45</b>
<b>5.13</b>	<b>Changing the current Date and Time</b>	<b>45</b>
<b>6</b>	<b><i>Battery Installation</i></b> .....	<b>47</b>
<b>6.1</b>	<b>Introduction</b>	<b>47</b>
<b>6.2</b>	<b>Safety</b>	<b>47</b>
<b>6.3</b>	<b>UPS Batteries</b>	<b>48</b>
<b>6.4</b>	<b>Installation Design Considerations</b>	<b>49</b>
<b>6.5</b>	<b>Battery Installation and Maintenance</b>	<b>49</b>
6.5.1	Temperature Considerations	49
6.5.2	Battery Population	49
<b>6.6</b>	<b>Battery Protection</b>	<b>50</b>
<b>6.7</b>	<b>Battery Cabinet and Racks</b>	<b>50</b>
6.7.1	Introduction	50
6.7.2	Specification	50
6.7.3	Battery racks	50
<b>6.8</b>	<b>Battery Installation</b>	<b>52</b>
<b>6.9</b>	<b>Battery Circuit Breaker Boxes</b>	<b>52</b>
<b>6.10</b>	<b>Battery Temperature Board</b>	<b>54</b>



<b>7</b>	<b><i>Display Panel Interpretation</i></b> .....	<b>55</b>
<b>7.1</b>	<b>LED Interpretation</b>	<b>55</b>
<b>7.2</b>	<b>Display Panel Messages</b>	<b>57</b>
<b>8</b>	<b><i>1 + N System</i></b> .....	<b>63</b>
<b>8.1</b>	<b>General</b>	<b>63</b>
<b>8.2</b>	<b>Installation Procedure</b>	<b>65</b>
8.2.1	Preliminary Checks	65
8.2.2	Protective Devices	65
8.2.3	Power Cables	65
8.2.4	Control Cables	65
8.2.5	Battery Control	66
8.2.6	Emergency Stop	66
<b>8.3</b>	<b>Operating Instructions</b>	<b>67</b>
8.3.1	System Start-up and Shutdown procedures (separate batteries)	67
<b>8.4</b>	<b>Display Panel Message Interpretation in '1+N' System</b>	<b>70</b>
<b>9</b>	<b><i>Specification</i></b> .....	<b>71</b>
<b>9.1</b>	<b>Conformity and Standard</b>	<b>71</b>
<b>9.2</b>	<b>UPS Environmental</b>	<b>71</b>
<b>9.3</b>	<b>UPS Mechanical Characteristics</b>	<b>71</b>
<b>9.4</b>	<b>UPS Electrical Characteristics</b>	<b>72</b>
<b>9.5</b>	<b>UPS Electrical Characteristics (DC Intermediate circuit)</b>	<b>73</b>
<b>9.6</b>	<b>UPS Electrical Characteristics (Inverter Output)</b>	<b>74</b>
<b>9.7</b>	<b>UPS Electrical Characteristics (Bypass Input Mains)</b>	<b>75</b>
<b>10.</b>	<b><i>ANNEXURE</i></b> .....	<b>77</b>
<b>10.1</b>	<b>Remote Alarm Monitor</b>	<b>79</b>
10.1.1	Ram Connections	79
<b>10.2</b>	<b>Input Transformer Cubicle</b>	<b>81</b>
10.2.1	Introduction	81
10.2.2	Termination	81
10.2.3	Indication and Metering	81
10.2.4	Protection	81
<b>10.3</b>	<b>Bypass Isolation Cubicle</b>	<b>82</b>
10.3.1	Introduction	82
10.3.2	Termination	82
10.3.3	Indication and Metering	82
10.3.4	Protection	82

--- X --- X --- X --- X ---  
--- X --- X --- X ---  
--- X --- X ---



# General Description

## 1.1 Introduction

The Hipulse Uninterruptible Power Supply (UPS) System is connected between a critical load, such as a computer, and its three phase mains power supply. Being designed to furnish a well regulated 1 phase output power supply under all rated load and input supply conditions, the system offers the user the following advantages:

*Increased power quality:*

The UPS has its own internal voltage and frequency regulators which ensure that its output is maintained within close tolerances independent of voltage and frequency variations on the mains power lines.

*Increased noise rejection:*

By rectifying the input a.c. power to d.c. power, and then converting it back to a.c., any electrical noise present on the input mains supply line is effectively isolated from the UPS output, therefore the critical load sees only clean power.

*Power blackout protection:*

If the mains power fails, the UPS continues to power the critical load from its battery source, leaving the load immune from power disturbances.

## 1.2 Design Concept

### 1.2.1 Hipulse Module Design

This section describes an individual module's operating principles. The UPS basically operates as an a.c. - d.c. - a.c. converter (see figure 1 -1 ). This first conversion stage (from a.c. to d.c.) uses a 3 phase, fully-controlled SCR bridge rectifier to convert the incoming mains supply into a regulated d.c. busbar.

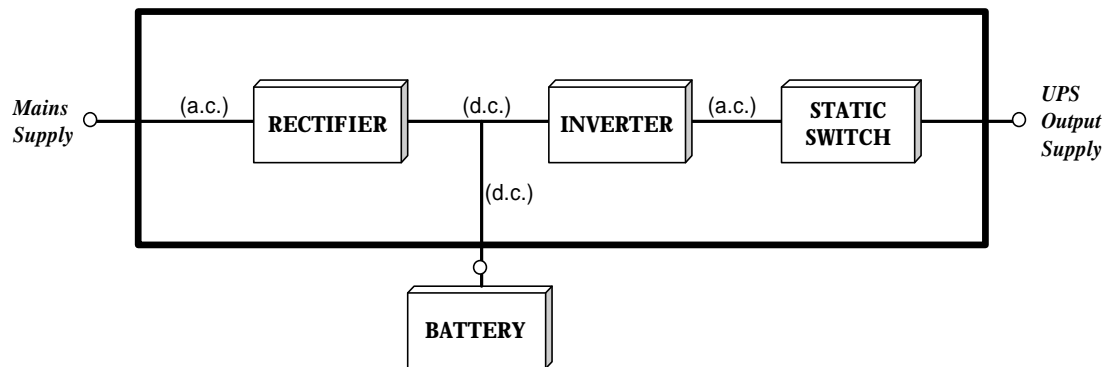

Fig 1-1 : Single Module block diagram

The d.c. busbar produced by the rectifier provides both battery charging power - being equipped with a temperature compensated battery charging system, to prolong battery life - and power to the inverter section - which utilizes the latest IGBT switching pulse width modulation (PWM) design - and provides the second conversion phase, i.e. reconverting the d.c. busbar voltage back into an a.c. voltage waveform.

During normal operation both the rectifier and inverter sections are active and provide regulated load power whilst simultaneously float charging the battery. In the event of a mains power failure, the rectifier becomes inoperative and the inverter is powered solely from the battery. Critical load power is maintained under these conditions until battery is fully discharged, where upon the UPS shuts down. The end of battery discharge is assumed when the battery voltage falls below a preset value (i.e. 330 / 340V d.c. for a 400 V a.c. system).

The period for which the load can be maintained following a mains power failure is known as the 'System's Autonomy Time' and is dependent upon both the battery A/Hr capacity and the applied percentage load.

### 1.2.2 Bypass Supplies

The circuit block annotated 'Static Switch' in figure 1-2 contains an electronically controlled switching circuit which enables the critical load to be connected either to the inverter output or to a bypass power source via the 'static bypass line'. During normal system operation the load is connected to the inverter and the 'inverter -side' of the Static Switch is closed; but in the event of a UPS overload, or inverter failure, it is automatically transferred to the static bypass supply line.

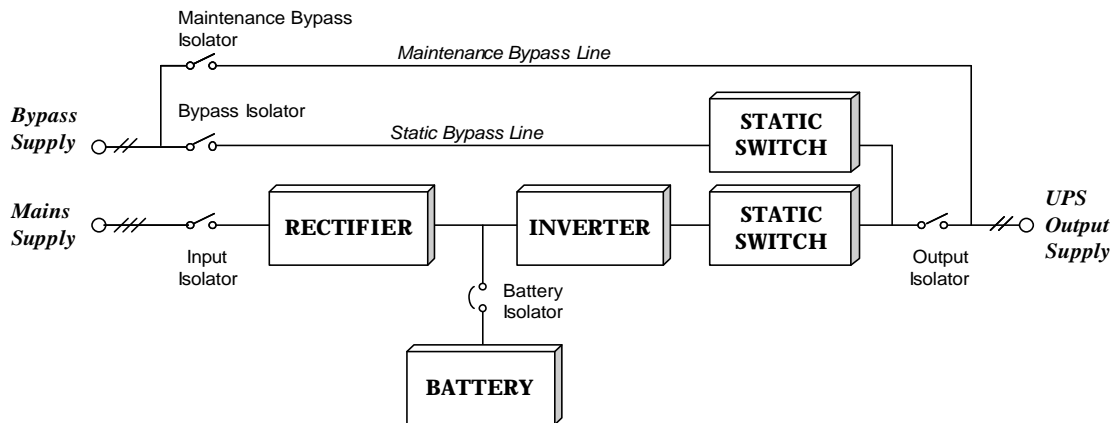

Fig 1-2 : UPS Power switches configuration

To provide a clean (no-break) load transfer between the inverter output and static bypass line, the static switch activates connecting the load to the bypass supplies. To achieve this, the inverter output and bypass supply must be fully synchronized during normal operating conditions. This is achieved through the inverter control electronics which make the inverter frequency track that of the static bypass supply provided that the bypass remains within an acceptable frequency window. The synchronizing window is pre-selected to 2% of nominal frequency, giving an acceptable frequency window  $\pm 1$  Hz.

A manually controlled, 'Maintenance Bypass' supply is also incorporated into the UPS design. Its purpose is to enable the critical load to be powered from the mains (bypass) supply while the UPS is shut down for routine maintenance.

*Note: The load equipment is not protected from normal supply aberrations when operating on Bypass side or in the maintenance bypass mode*

### 1.2.3 System Control Philosophy

#### **Normal Operation**

During normal operation, i.e. when the UPS input supply is present and within specification, both the rectifier and inverter sections are active and the static switch is turned on to connect the inverter output to the critical load busbars. The battery circuit breaker is also closed and the battery is therefore permanently float charged at the d.c. busbar voltage level.

#### *(1+N Parallel UPS System)*

**Note:** As the unit outputs are connected in parallel, the System checks that the inverter control circuits are perfectly synchronised with one another and with the Bypass Mains in terms of both frequency and phase and that they have the same output voltages. Current supplied to the load is automatically divided among UPSs. A warning message appears while synchronisation is in progress.

A module's static switch cannot close until these conditions are satisfied.

#### **Mains Failure**

If the power mains has a failure or is out of tolerance the rectifier will go off automatically, while the Inverter will continue to operate on power from the battery for a period of time which depends on the load and the capacity of the battery. If the mains supply has not returned within this time, the Inverter will go off automatically and an alarm message will appear on the UPS operator control panel display.

Critical load will not be interrupted in the event of a drop or return of the AC power mains.

#### **Return of power mains**

When the mains return within the required tolerance, the Rectifier will start up again automatically and gradually (power walk in), supplying power to the Inverter and recharging the battery at the same time. There will be no interruption of the critical load.

#### **Off-Battery**

If the battery system only is taken out of service for maintenance, it is disconnected from the rectifier/ charger and inverters by means of (an) external disconnect breaker(s). The UPS shall continue to function and meet all of the specified steady-state performance criteria, except for the power outage back-up time capability.

#### **UPS Module fault**

In the event of an Inverter fault, the Static Transfer Switch will automatically transfer the load onto the Bypass Mains with no interruption. In such an event, request qualified technical assistance.

#### *(1+N Parallel UPS System)*

In the event of a fault in a unit, the unit's Static Transfer Switch will automatically exclude the unit from the system. If the system is still capable of providing the required load, the remaining units will continue to supply the load with no interruption. When the units still present in the system are no longer capable of fulfilling power requirements, the load will automatically be transferred onto the MSS Bypass Mains. The load will be transferred with no interruption if the Inverters are synchronised with the network; if this is not the case, there will be an interruption lasting about 20 milliseconds.

### **Overload**

In the event of an overload at the Inverter output which lasts longer than the typical time/ current (refer to Chapter 9 - Specifications), the Inverter will shut down and the Static Transfer Switch will automatically transfer the load onto the MSS Bypass Mains with no interruption. If the overload falls within the typical time/ current that has been specified, the load will be returned to the inverters when the power drops to a level which can be supported by the number of active units in the system (parallel 1 +N).

In the event of a short circuit in the output, the load will normally be transferred onto the MSS Bypass Mains, which will cause the Inverter to shut down; this switch is determined above all by the features of the protective devices in use in the system. In either case, an alarm message will appear on the UPS operator control panel display.

#### *(1+N Parallel UPS System)*

The control logic system constantly monitors load requirements and controls the power supplied by the UPS modules. In the event that an overload condition is sustained for greater than a preset time, the load will transfer to the mains bypass supply, when the number of active modules are unable to satisfy load requirements. The load returns to the inverter supply if the power is reduced to a value that can be sustained by the number of active modules in the system.

### **Maintenance Bypass**

A second bypass circuit contained in the UPS cabinet, identified as the 'Maintenance Bypass' line is included to enable a 'raw' mains supply to be made available to the load while facilitating a safe working environment for carrying out scheduled UPS system maintenance or troubleshooting. The circuit is manually selected by the Maintenance Bypass Isolator which can be padlocked in the OFF position.

#### **WARNING**

The internal maintenance bypass must not be used when the UPS system is comprised of more than two UPS modules in parallel.

#### **CAUTION**

If an automatic circuit breaker device is not present in the input distribution panel, there remains a dangerously high voltage at the output busbars of the UPS module that is switched off

#### 1.2.4 ECOMODE

In this operating mode the System prefers to put the load on the Bypass Mains, with the Inverter on stand-by. The load is switched over to the Inverter when the mains goes outside of standard frequency and voltage values (or the values as modified using the operator panel when starting up the system). The ECOMODE configuration requires a different setup in the default menu configuration, which may be prepared in the factory before shipment or during installation by personnel trained in the use of the System.

**Note:** *In order to operate in ECOMODE, UPSs must be provided with compatible software versions:*

The 'UPS Logic' card must be *release 9.0* or later (the S/W release of the cards may be read on the front panel display, referring to Section 4.1.2 - Operating Instructions).

Operating Instructions in ECOMODE are the same as those described in Chapter 5, except that the load is normally on the Bypass mains, the Load LED is normally on Inverter (5), and corresponding alarm message will be replaced with Load on Mains (6).



**WARNING**

In ECOMODE the load is not protected against mains distortion.

1.2.5 UPS Power Switch Configuration

Figure 1-2 illustrates the Hipulse UPS module in what is known as the "Split Bypass" configuration. In the Split Bypass configuration, the static bypass line is connected by a separate power switch to a dedicated 'bypass' power source which also feeds the maintenance bypass line. Where a separate power source is not available the Bypass (Q2) and Rectifier input supply connections would be linked together.

With the exception of maintenance bypass isolator, all the isolators shown must be closed during normal UPS operation.

1.2.6 Battery circuit breaker

The battery should be connected to the d.c. busbar through a circuit breaker fitted inside the battery cabinet or located adjacent to batteries where a battery cabinet is not used. This circuit breaker is closed manually, but it contains an undervoltage release coil which enables it to be tripped from the UPS control electronics following certain detected faults. It also has a magnetic trip facility for overload protection.

1.2.7 Battery temperature compensation

Hipulse UPS System offers a battery temperature compensation circuit. As the temperature inside the battery cabinet area rises, the d.c. busbar voltage reduces in order to sustain the battery at its optimum charge voltage. This must be used in conjunction with the battery sensor board.

1.2.8 System Expansion

If necessary, a single -module system can be expanded to cater for an increased load requirement by adding additional modules - upto a maximum of six UPS modules can be connected in parallel. System expansion requires change in the SETUP of the display panel.

***Note:** System expansion should be carried out only by trained service personal. The individual modules connected to the system must be of the same power rating*



## CHAPTER 2

# Installation Procedure

### 2.1 Introduction

#### WARNING

Do not apply electrical power to the UPS equipment before the arrival of the commissioning engineer.

---

#### WARNING

The UPS equipment should be installed by a qualified engineer in accordance with the information contained in this chapter and all equipment not referred to this manual is shipped with the details its own mechanical and electrical installation.

---

#### WARNING - Battery Hazards

- Special care should be taken when working with the batteries associated with this equipment. When connected together, the battery terminal voltage will exceed 400V DC, and is potential lethal.
  - Eye protection should be worn to prevent injury from accidental electrical arcs.
  - Remove rings, watches and all metal objects.
  - Only use tools with insulated handles.
  - Wear rubber gloves.
  - If a battery leaks electrolyte, or is otherwise physically damaged, it must be replaced, stored in container resistant to sulfuric acid and disposed of in accordance with local regulations.
  - If electrolyte comes into contact with the skin, the affected area should be washed immediately with water.
- 

#### NOTE

The UPS System can be connected to an IT (isolated neutral) power system

---

This section describes the UPS system's environmental requirements and mechanical considerations that must be taken into account when planning the positioning and cabling of the UPS equipment.

*Because every site has its peculiarities, it is not the aim of this chapter to provide step-by-step installation instructions, but to act as a guide as to the general procedures and practices that should be observed by the installing engineer.*

## 2.2 Environmental considerations

### 2.2.1 UPS location

The UPS module should be located in a cool, dry, clean-air environment with adequate ventilation to keep the ambient temperature within the specified operating range (see Chapter 9 - Specifications).

All models in the 'Hipulse' UPS range are cooled with the aid of internal fans. Cooling air enters the module through ventilation grills located at various parts of the cabinet and exhausted through grills located on the back of UPS. When the cabinet is located on a raised floor, and bottom cable entry is used, additional cooling air also enters the UPS via the floor void. If necessary, a system of extractor fans should be installed to aid cooling air-flow, and a suitable air filtration system used where the UPS is to operate in a dirty environment.

***Note 1:** When batteries are cabinet-mounted adjacent to the UPS module, it is the battery which dictates the designed maximum ambient temperature, not the UPS.*

***Note 2:** Power losses from the System which may be used in an air conditioning system are intended for operation using the Inverter, as in the ECOMODE configuration they would be undersized.*

### 2.2.2 Battery location

Temperature is a major factor in determining the battery life and capacity. Battery manufacturers quote figures for an operating temperature of 20°C. Operating above this temperature will reduce the battery life, operation below this temperature will reduce the battery capacity. On a normal installation the battery temperature is maintained between 15°C and 25°C. Batteries should be mounted in an environment where the temperature is consistent and even over the whole battery. Keep batteries away from main heat sources or main air inlets etc.

The batteries can be mounted in purpose-built battery cabinet, which is positioned adjacent to the UPS module. Pedestals are required for the battery cabinets when they are located on raised floors, in the same way as for the UPS cabinets. If the batteries are rack-mounted, or otherwise located remote to the main UPS cabinet, a battery circuit breaker must be mounted as close as possible to the batteries themselves, and connected using the most direct route possible. A customized remote battery circuit breaker box, containing the circuit breaker and its necessary control board, is also available as a standard option.

## 2.3 Mechanical Considerations

### 2.3.1 System composition

A UPS system can comprise a number of equipment cabinets, depending on the individual system design requirements - e.g. UPS cabinet, Battery cabinet. In general, all the cabinets used in a particular installation are of the same height and designed to be positioned side-by-side to form an aesthetically appealing equipment unit.

### 2.3.2 Moving the cabinets

#### **WARNING**

Ensure that any lifting equipment that used in moving the UPS cabinet has sufficient lifting capacity.

Ensure that the UPS weight is within the designated surface weight loading (Kg/sq.cm.) of any handling equipment. See the UPS specification for weight details.

The UPS cabinets can be moved by fork lift or crane. For operations with fork lift, it is necessary to remove both the front, rear (or side) grille panels located on the base of the cabinet. To enable the cabinet to be lifted by a crane, removable lifting bars, are fitted to the top of the cabinet.

In the eventuality that the equipment cannot be moved by fork lift or crane, then rollers should be used.

### 2.3.3 Clearances

As Hipulse has no ventilation grills at either the sides or the rear, no clearances are required. Back -access is not an essential requirement for maintenance; however, where space permits, a clearance of approximately 1000mm will ease access to magnetic component parts. This will also ensure proper exhaust from rear. Clearance around the front of the equipment should be sufficient to enable free passage of personnel with the doors fully opened.

### 2.3.4 Fixing magnetic components

After the equipment is in place, remove the transportation restraints that hold the output transformer in place.

### 2.3.5 Cable entry

Cables can enter for 'Hipulse' UPS and battery cabinet either from below or through either side. Side entry is made possible by removing blanking pieces fitted in the side panel to reveal the cable entry holes. This cable entry method allows the equipment to be positioned on a solid floor without the need for cable trenching and allows cables to pass from one module to the other when positioned side-by-side.

**Note:** When selecting the power cables for side entry to a module located on a solid floor, consideration must be given to the minimum permissible bending radius of the proposed cables to ensure that they can be fashioned to reach the UPS connection busbars.

## 2.4 Preliminary Checks

Before you install the UPS hardware you should carry out the following preliminary checks:

1. Verify that the UPS room satisfies the environmental conditions stipulated in the equipment specification, paying particular attention to the ambient temperature and air exchange system.
2. Remove any packaging debris, then visually examine the UPS and battery equipment for transit damage, both internally and externally. Report any such damage to the shipper immediately.

## 2.5 Installation Drawings

The following diagrams illustrate the key mechanical characteristics of the various UPS system cabinets

Fig 2-1: Overall General Arrangement for 130 kVA Single Phase 110V UPS with 6 Pulse rectifier Single Module and '1+N'

Fig 2-2: Cable entry and Foundation details for 130 kVA Single Phase 110V UPS with 6 Pulse rectifier Single Module and '1+N'.

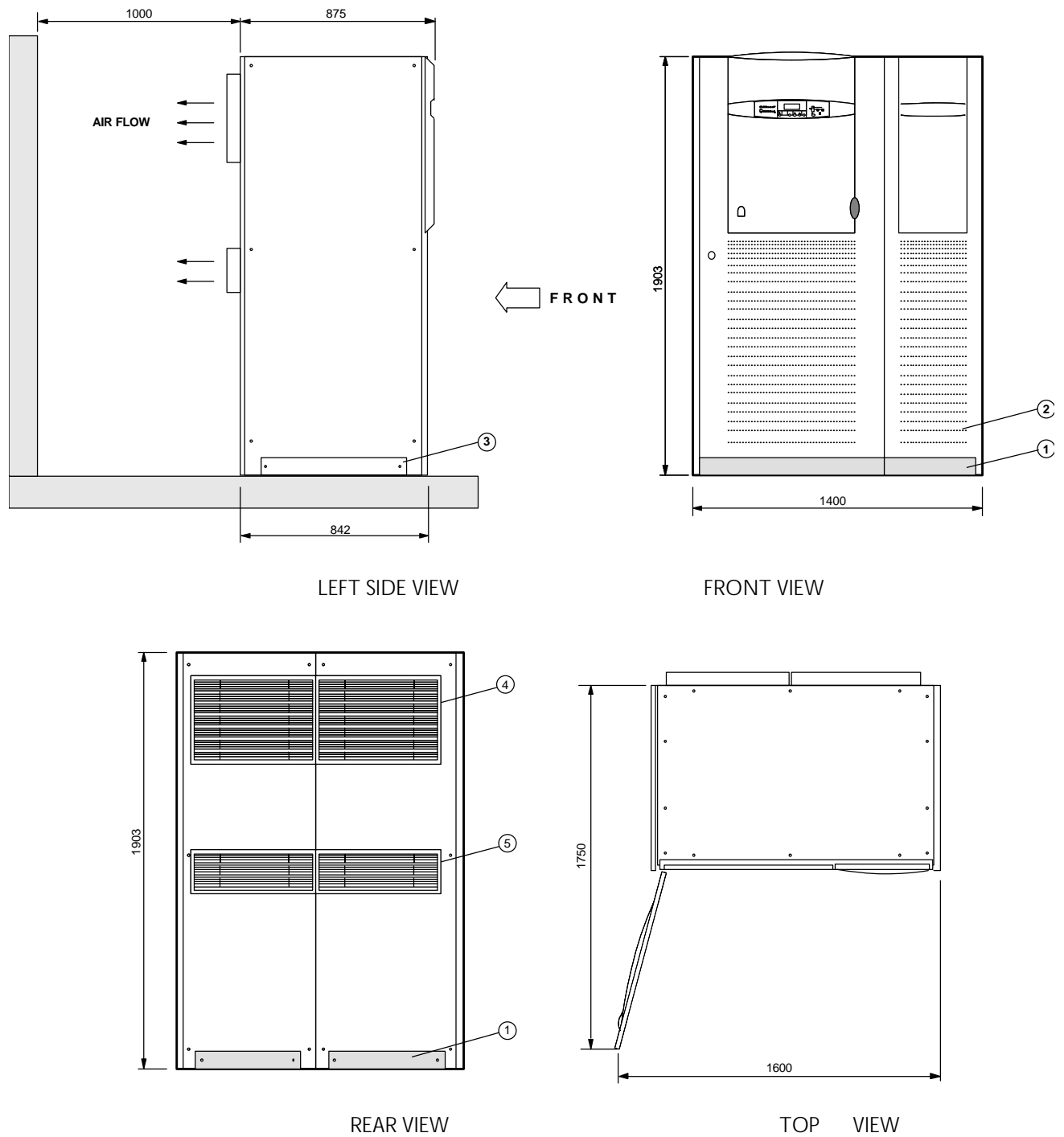

Note - All dimensions are in mm

1. Removable grill for lifting with fork-lift truck
2. Air inlet grill
3. Removable grill – if using side cable entry
4. Cooling fan assembly for Rectifier & Inverter
5. Cooling fan assembly for Transformers

Fig 2-1: Overall General Arrangement for 130kVA Single Phase UPS

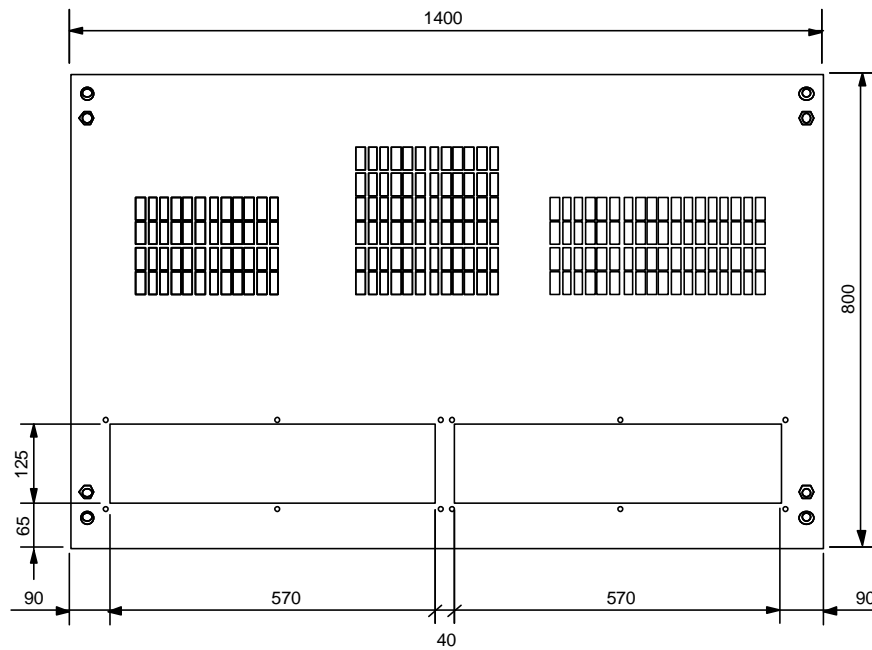

A. CABLE ENTRY DETAILS

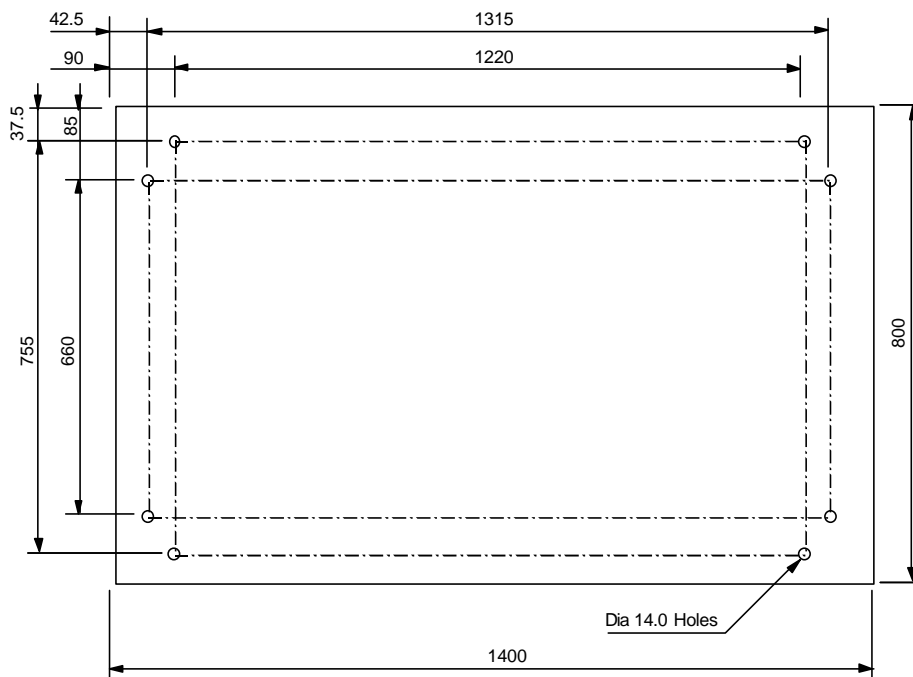

FOUNDATION DETAILS

Note: All dimensions are in mm

Fig 2-2 : Cable entry and Foundation details for 130 kVA Single Phase UPS



## Installation (Electrical)

The UPS requires both "Power" and "Control" cabling once it has been mechanically installed. All Control cables, whether screened or not, should be run separate from the Power cables in metal conduits or metal ducts which are electrically bonded to the metalwork of the cabinets to which they are connected.

### 3.1 Power Cabling

#### WARNING

Before cabling-up the UPS, ensure that you are aware of the location and operation of the external isolators that connect the UPS input/bypass supply to the mains distribution panel.

Check that these supplies are electrically isolated, and post any necessary warning signs to prevent their inadvertent operation.

---

For cable entry, refer to section 2.3.5

#### 3.1.1 System Configuration

The power cables of the system must be sized with respect to the following description:

##### ***Module input cables***

The module input cables must be sized for the maximum input current, including the maximum battery recharge current, given in the table 3-1, with respect to the module rating and the input a.c. voltage.

##### ***Module Bypass and Output cables***

The Bypass and Output cables must be sized for the nominal output current, given in the table 3.1, with respect to the module rating and the output a.c. voltage.

##### ***Battery cables***

Each UPS module has its own battery, which is connected using two cables, one positive and one negative. The battery cables must be sized for the battery discharge current at the end-of-discharge voltage, as given in the table 3-1, with respect to the module rating.

### 3.1.2 Cable rating

UPS Rating (kVA)	NOMINAL CURRENT (Amps)								
	3 Phase Input Mains with full battery re-charge (less 5% for 12 pulse)			1 Phase Output at full load			Battery at minimum Battery Voltage		
	380V	400V	415V	110V	115V	120V	380V	400V	415V
30	63	60	58	272	260	250	83	80	77.5
40	84	80	77	364	349	334	110	106	103
50	105	100	96	454	434	416	137	133	129
60	126	119	115	545	521	500	164	159	155
80	165	157	151	727	695	666	219	213	206
120	245	233	223	1090	1043	1000	329	319	310
130	259	247	238	1181	1130	1083	357	346	336
150	300	285	275	1363	1304	1250	412	399	387

Table 3-1 UPS Module cabinet power cable rating

### 3.1.3 General Notes

The following are guidelines only and superseded by local regulations and codes of practice where applicable:

1. The neutral conductor should be sized same as the output/ bypass current.
2. The earth conductor should be sized for carrying fault current for atleast 3 to 5 seconds or as guided by local electrical rules.
3. Consideration should be given to the use of paralleled smaller cables for heavy currents, as this can ease installation considerably.
4. When sizing battery cables, a maximum volt drop of 3V d.c. is permissible at the current ratings given in Table 3-1.

### 3.1.4 Cable Connections

The rectifier input, bypass, output and battery power cables (all require lug type terminations) and are connected to busbars situated below the power isolator switches - as shown in figure 3.1 for 80kVA and fig 3.2 for 120 /160/ 200kVA.

A terminal block X3 is used for connecting the control cables to the battery circuit breaker and a second terminal block X4 is used for the external emergency stop facility, external OFF inverter, ext. Bypass, etc. these are female spade type connections (Fast-on 6.3 x 0.8) and are described later in Section 3.2

### 3.1.5 Safety earth

The safety earth busbar is located between the Bypass and Output power supply connections as shown in the figure 3.1. The safety earth cable must be connected to the earth busbar and bonded to each cabinet in the system.

All cabinets and cable trunking should be earthed in accordance with local regulations.

**WARNING**

Failure to follow adequate earthing procedures can result in electric shock hazard to personnel, or the risk of fire, should an earth fault occur.

3.1.6 Protective devices

For safety reasons, it is necessary to install, external to the UPS, circuit breaking protective devices in the input a.c. supply and towards the battery. Given that every installation has its own characteristics, this chapter provides general useful information engineers, with knowledge of operating practices, of regulatory standards, and of the equipment to be installed.

Rectifier and bypass inputs:

Protection against excessive over currents and short circuits

These inputs must be protected, installing suitable protective devices at the distribution panel of the incoming main supply, considering that the protection should discriminate with overload capacity of the system (see Chapter 9: Specification - Electrical Characteristics).

**Split Bypass :**

In the case of a split bypass being used, separate protective devices should be installed in the incoming mains distribution panel.

The protective devices must be selected for the nominal input current, with respect to the UPS rating and the input a.c. supply voltage as given in table 3-1.

**Protection against earth faults (RCD devices):**

In the event of a differential (RCD) device being installed upstream of the input supply, one must take into account transient and steady state earth leakage currents that are produced during start-up of the UPS.

The presence of an RFI suppression filter inside the UPS, determines a residual earth current greater than 3.5mA and less than 1000mA.

Residual current circuit breakers (RCCB) must be sensitive to d.c. unidirectional pulse (class A) in the network and insensitive to transient current pulses.

They are identified by the symbols respectively.

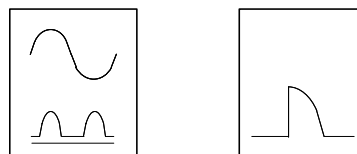

These isolators must have an average sensitivity, possible adjustable between 0.3 and 1A.

It is recommended that the selectivity with every differential switch be verified both upstream of the input distribution board and downstream (towards the load).

**Parallel 1+N:**

Use of differential circuit breakers on UPS unit inputs in a configuration with separate inputs and one battery for each unit requires installation of a common device only on the System Bypass Mains.

Use of differential circuit breakers on UPS unit inputs sharing a common battery requires installation of device common to all the input lines. If inputs are configured for separate mains, a common device will also be required for all System bypass mains.

**UPS Battery:**

The UPS Battery is protected by means of a control circuit that operates the tripping mechanism of an automatic circuit breaking device (having a variable trip setting). The tripping mechanism using an undervoltage release coil that operates on a present minimum voltage level.

The circuit breaker is essential for maintenance of the battery and is normally located near to the battery installation. The characteristics and operation of the automatic circuit breaker are given in Chapter 6.

**Output of the System:**

In the eventuality that an external distribution panel is used for load distribution, the selection of protective device must provide discrimination with those that are used at the input to the UPS module.

**3.1.7 Cabling procedure**

Once the equipment has been finally positioned and secured, connect the power cables as described in the following procedure.

Study the connection diagram in the figures below.

1. Verify that the UPS equipment is totally isolated from its external power source and all the UPS power isolators are open. Check that these supplies are electrically isolated, and post any necessary warning signs to prevent their inadvertent operation.
2. Open the door(s) to the UPS cabinet and remove the lower protective cover to gain access to the connections bars.
3. Connect the safety earth and any necessary bonding earth cables to the copper earth bus busbar located on the floor of the equipment below the power connections.

**Note:** *The earthing and neutral bonding arrangement must be in accordance with local and national codes practice*

**Input Connections:**

4. Connect the a.c. input supply cables to the input busbars (U1-V1-W1 terminals) and the bypass a.c. supply cables to the bypass busbars (U3 - N3 terminals) and tighten the connections.

ENSURE CORRECT PHASE ROTATION

**Output System Connections:**

5. Connect the system output cables between the output busbars (U2 - N2 terminals) and the critical load and tighten the connections.

**WARNING**

If the load equipment will not be ready to accept power on the arrival of the commissioning engineer then ensure that the system output cables are safely isolated at their ends.

6. Connect the Battery cables between the UPS terminals (+/ -) and its associated battery circuit breaker. Connect screened auxiliary cables from each battery circuit breaker control board to the auxiliary terminal block (X3) of UPS of their metal frame of the Battery breaker mounted in input transformer cubicle or Battery circuit breaker box (if used).

As a safety precaution remove the battery fuse in the module until the arrival of commissioning engineer.

OBSERVE THE BATTERY CABLE POLARITY

**WARNING**

Do not close the battery circuit breaker before the equipment has been commissioned.

***Input-module Parallel Connections:***

7. 1+N Parallel UPS System: Inside the module there is an Parallel Connectors Board mounted on the left hand side. Connect one end of the interconnecting ribbon cables to interface connector (X1) of the first UPS module and the other end to connector (X2) of the second module, and so to the next module until a closed loop is formed. (see fig 8-2).

***Auxiliary Connections:***

8. Connect the auxiliary cables of any external interface/ signals to the respective connections of the output auxiliary terminal block (X4).

9. Refit the lower protective cover.

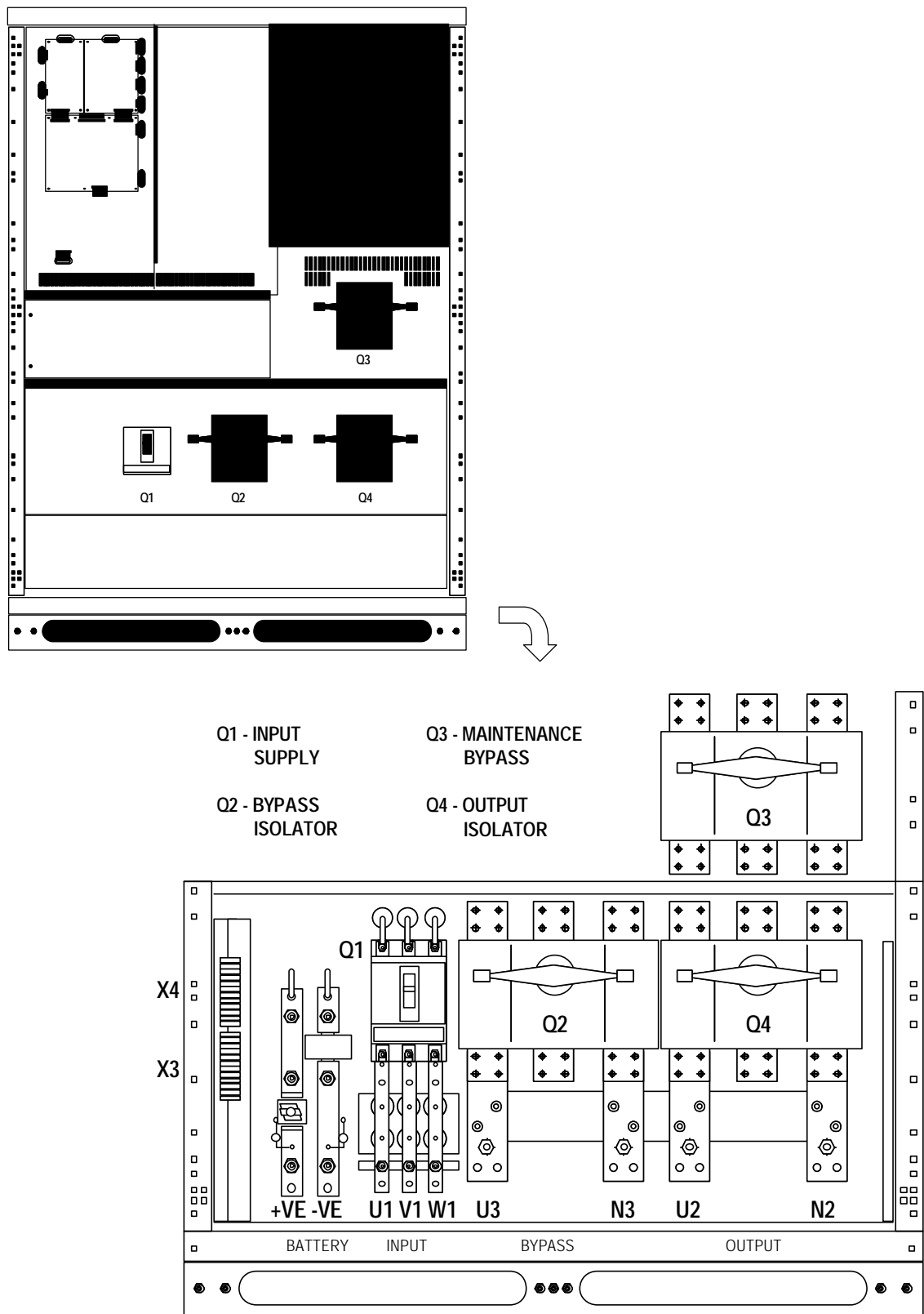

Fig 3-1 : Cable connections for 130 kVA 1Ph UPS

## 3.2 Control cables

### 3.2.1 Battery Control

The battery circuit breaker is controlled by the Battery Circuit Breaker Controller Board which is located within the Input Transformer Cubicle - or adjacent to the Battery Circuit Breaker when the batteries are rack-mounted. This board controls the circuit breaker's undervolts release coil and also provides a path for the circuit breaker auxiliary contacts to signal the circuit breaker status back to the UPS control logic. All the connections between the controller board and the UPS module are made via the Auxiliary Terminal Block which is located in the base of the UPS cabinet.

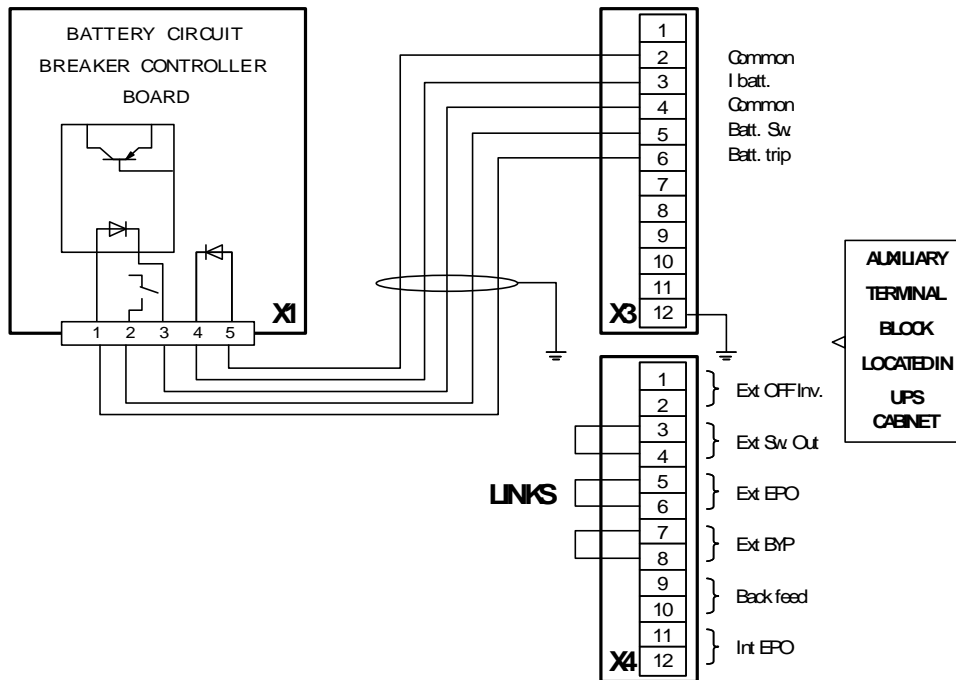

Fig 3-2 : Auxiliary Terminal Block detail

Connect the battery circuit breaker control and temperature compensation cables between the UPS auxiliary terminal block and battery circuit breaker controller board as shown in figure 3-3. These cable must be shielded, shield should be connected at protective earth of Input transformer cubicle or battery breaker, not of UPS.

#### CAUTION

If battery temperature compensation is not used the system must be de-activated by commissioning engineer.

### 3.2.2 Auxiliary Terminal Block X3 and X4 at UPS

X3 terminal reference	Reference label	Description
2	Common	Temperature sensor common (0V)
3	T Batt.	Temperature sensor signal
4	Common	Common (0V)
5	Batt. Sw.	Battery circuit breaker trip control
6	Bat Trp	Battery circuit breaker trip control

**Note:** *The auxiliary cables of the battery must be screened and double insulated. The screen is connected to the earth of the battery cabinet or supporting rack. Use multiple-core shielded cables with a section of 0.5 to 1mm<sup>2</sup> Connect the cables with the Fast-on 6.3 x 0.8 mm terminals (female)*

X4 terminal reference	Reference label	Description
1-2	Ext. OFF Inv	Remotely provides control for switching off the inverter. Normally open contact.
3-4	Ext. Sw. Out	Indication to be provided at the UPS to note the opening of an external module output isolator. Normally closed contact. If unused, leave the standard connectors in place.
5-6	Ext. EPO	Remotely provides control for switching off the UPS using a remote emergency button. Normally closed contact. If unused, leave the standard connectors in place.
7-8	Ext. BYP	Indication to be provided at the UPS to note the opening of an external maintenance bypass switch. Normally closed contact. If unused, leave the standard connectors in place.
9-10	Back Feed	Signal form the UPS to indicate a return flow of energy in the bypass mais. Normally open contact.
11-12	Int. EPO	Availability of a contact for switching off the UPS in the same way as the internal emergency off button. Normally closed contact.

**Note:** *All auxiliary cables of terminal block X4 must be double insulated. The cross-sectional area of the auxiliary cables is from 0.5 to 1 mm<sup>2</sup> Connect the cables with the Fast-on 6.3 x 0.8 mm terminals (female) Maximum contact rating on auxiliary terminals: 50 Vdc @ 1 Amp.*



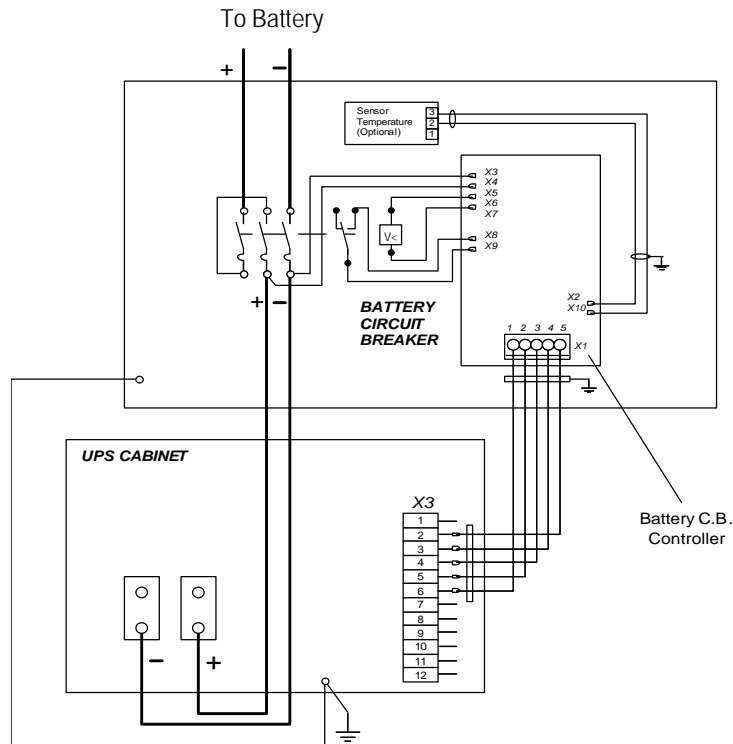

Fig 3-3: Battery Connection

### 3.2.3 Emergency Stop

If an external Emergency Stop facility is required it is connected to terminals 5 & 6 of the Auxiliary Terminal Block (X4) and connect the 'normally closed' remote stop switch between these two terminals using shielded cable. If this facility is not used then terminals 5 & 6 must be linked-out as shown in Figure 3-3.

**Note:** The Emergency Stop action within the UPS shuts down the rectifier, inverter and static bypass and trips the battery circuit breaker. It does not however internally disconnect the input mains supply. If required, this additional action can be facilitated by feeding the UPS input via a circuit breaker which can be tripped by a second contact of the Emergency Stop switch.

**Note:** Terminals 11 and 12 of the Auxiliary Terminal Block (X4) are connected to a normally closed contact of the UPS Display Panel Emergency Stop button and go open circuit when the button is pressed. This output can be used as part of a wider Emergency Stop system to initiate an external action (such as tripping an external supply breaker)

### 3.2.4 Back Feed Protection

Using an auxiliary terminal (pins 9-10 of connector X4) the UPS provides a normally open contact to be used for opening of an external circuit protection device, to protect the operator against back feed of energy resulting from a short-circuit fault of the Bypass line SCRs. This auxiliary contact can be used, for example, in series with an external low voltage source, in order to supply the trip coil of an automatic circuit breaking device, located upstream of the UPS Bypass mains input. In the vent of energy being backfeed the auxiliary circuit will activate closing the normally open contact and as a result opening of the external circuit-breaking device; the UPS is disconnected from the Bypass mains supply. The electrical characteristics of the auxiliary contact are 50V (a.c. or d.c.) @ 1 Amp.



# Operator Control and Display Panel

## 4.1 Introduction

On the front of the UPS there is a display and control panel, from which it is possible to easily verify the status of the UPS included all the measured parameters and alarms of the UPS and Battery. The operator control panel is divided into three functional areas:

'Mimic LED display' and Inverter Control switch,  
'Operator Panel' and 'LCD display',  
'Bargraph section'.

As can be seen the left section consists of LEDs which indicate the operational and alarm status of the system by turning ON or OFF or by flashing ON/ OFF.

The middle section of the operator control and display panel consists of a LCD (Liquid Crystal Display) and its associated switches.

The following functional area (right section) shows the various UPS load and Battery charging conditions.

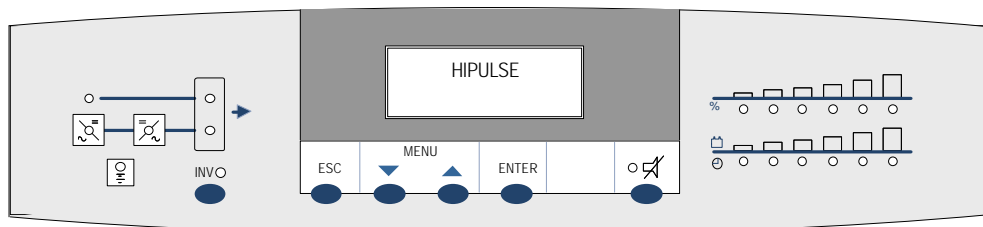

Fig 4-1: UPS Operator Control / Display Panel

#### 4.1.1 Operator control panel

The control and display panel LED indications are illustrated in figure 4-2 and described in the following text:

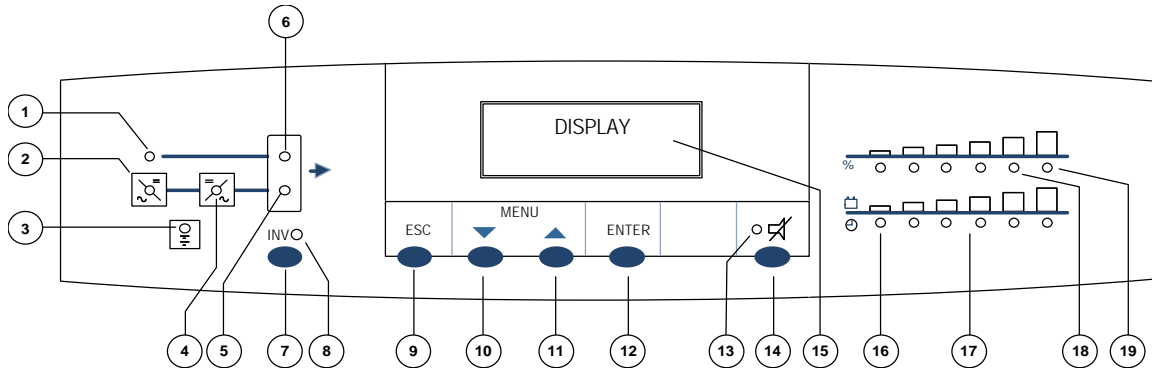

Fig 4-2: Single module operator control panel

#### **Mimic indications**

Six LED's mounted on a single line diagram represents the various UPS power paths and show the current UPS operation status:

##### 1. Bypass supply healthy

This led illuminates when the bypass a.c. input power switch is closed and the input supply is within of set value nominal voltage (default  $\pm 10\%$ )

2. Input supply healthy and Rectifier is operative.

3. Battery voltage healthy (i.e. between 'under - voltage cut-off' and 'over - voltage trip' levels).

4. Inverter output healthy.

##### 5. Load on Inverter status

This led illuminates when the output power switch is closed and the load is connected to the inverter.

##### 6. Load on Bypass status.

This led illuminates when the output power switch is closed and the load is connected to the bypass a.c. supply via the static switch.

#### **Inverter control switch**

7. Inverter ON (Only for UPS above 80kVA rating) - Manual inverter selection switch.

8. Inverter LED - inverter status indicator contained within the switch icon.

The Inverter LED (yellow) indicates when the Inverter is switched OFF.

### **Menu Control switches**

Four push button switches ESCape[9], DOWN [10], UP [11], ENTER [12], are located below the LCD display and are used to navigate a menu-driven UPS operating and control system.

*Note: In addition to entering the day-to-day operating functions, the menu system is also used to set-up various UPS operating parameters during commissioning. A system of password protection is therefore used to limit the control functions accessible to the operator, whilst allowing full access to maintenance personnel. A full description of the available menus is provided in the appropriate User and Commissioning manuals.*

*Note: From the Display panel menu it is possible to select one of the following languages: English, French, Italian, Spanish, German, Dutch. The sequence is Default window > FUNCTION > ENTER PASSWORD > PANEL SETUP > LANGUAGE*

9. ESC Pressing the ESCAPE cancels the most recent actions;  
i.e. when selecting options it returns the previous window to the LCD.  
when setting parameters, it exits the window without saving the new settings.
10. MENU ∨ The DOWN push button moves a cursor down the LCD over the options offered on certain windows, and changes the highlighted parameter values in others.
11. MENU ∧ The UP push button moves a cursor up the LCD over the options offered on certain windows, and move a rectangular cursor to the next digit on the right when changing parameter values in others;
- 12 ENTER Pressing ENTER, when selecting options, displays the next window;  
The next window is determined by the option which has been selected in the present window. When selecting new parameters its saves the new parameters.
- 13 Warning indicator - The red LED with the Alarm Silence switch illuminates when a WARNING alarm is displayed on the LCD message screen, and is normally accompanied by an audible alarm.
14. Alarm Silence Switch - Pressing the Alarm Silence switch cancels the audible alarm but leaves the warning message display until the inappropriate condition is rectified.

### **Operator Panel and LCD Display**

#### 15. LCD Display

The LCD display is capable of showing four rows of 20 characters: the top row displays the UPS warning and alarm messages and the lower row indicate the selected metered parameters.

During normal operation the top line of the LCD panel shows the general UPS Status (e.g. NORMAL OPERATION) and the bottom line will indicate the current time and date - this is known as the 'Default Screen'. Pressing the ESCape button [9] changes the displayed information to indicate the Communication Port status (if connected) and the version of the software fitted to the UPS control boards.

Pressing the ENTER button [12] from the Default Screen gives the operator access to the 'Measurements' menu which facilitates access to the following measurements:

*Output Parameters*

- Output Voltage (L-N)
- Output Current (L-N current displayed in Amperes or as a % Load)
- Output Power (displayed in kW or kVA)
- Output Frequency (of inverter and bypass mains)

*Input Parameters*

- Input Voltage (L-N for Bypass input)

*Battery Parameters*

- Battery Voltage
- Battery Current
- Battery Charge (in %)

*Temperature*

- Temperature (°C) at critical points

**Bargraph Selection**

This following functional area shows the various UPS load and battery charging conditions.

**16. Load Battery**

The amber led situated at the beginning of the % Autonomy bargraph illuminates when the battery voltage has discharged to 1.8V /cell and indicates that the battery is approaching its low voltage cut-off point and the UPS will shortly shutdown.

**17. % Battery state Autonomy time bargraph**

When the battery is being charged (normal) the six leds illuminate progressively to indicate the state of battery charge as a percentage of a charge. When the battery is discharging (battery on-load) the bargraph function changes to provide an indication of the remaining battery autonomy time, each step indicate approximately 2 minutes. With a fully charged battery all five LEDs are illuminated indicating greater than 10 minutes remaining, as the autonomy falls below this time the LEDs will extinguish in steps starting from the right-hand end.

**18. % Load bargraph**

The six leds illuminate progressively to indicate the applied load as a percentage of the rated maximum current increasing in 20% steps to 100% of full load when all five are illuminated.

**19. Overload**

The amber LED situated at the end of the % Load bargraph illuminates if the applied load exceeds 100% of modules rated output current. This indication will be accompanied by an audible alarm a alarm message.

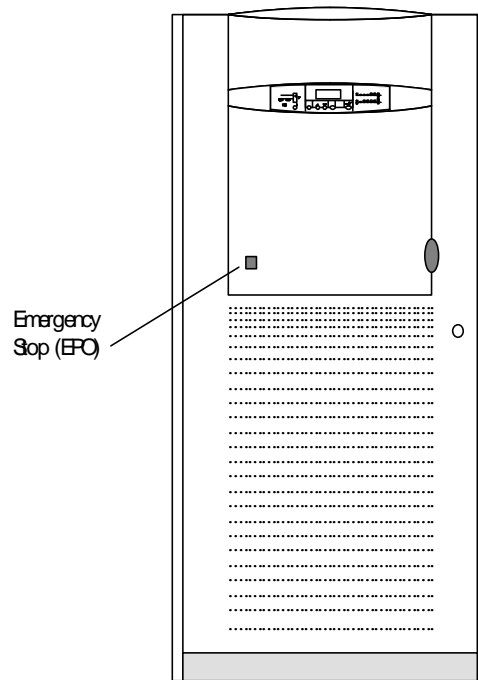

Fig 4 - 3: EPO on UPS module

20. Emergency Stop - housed beneath a safety cover to prevent inadvertent operation.

When the emergency stop switch is pressed it disables the static switch block entirely (so removing load power). It also disables the rectifier and inverter, and trips the battery circuit breaker. Under normal circumstances it does not remove UPS input power since this applied through a manually controlled external isolator; however, if the UPS input supply is connected via a circuit breaker having an electrical trip facility, another section of emergency power off can be used to drive the external circuit breaker's trip.

#### 4.1.2 The Menu Options

A map of the routes to the options offered by the menu is provided in figure below. Options include windows which show status information and windows which permit data to be entered, or parameters for equipment control to be set. The menu map shows that the route pass from the main menu through different intermediate windows to reach the option targeted. The diagram shows each of the windows in the format in which it appears on the LCD screen. The initializing, default & main menu windows are described below.

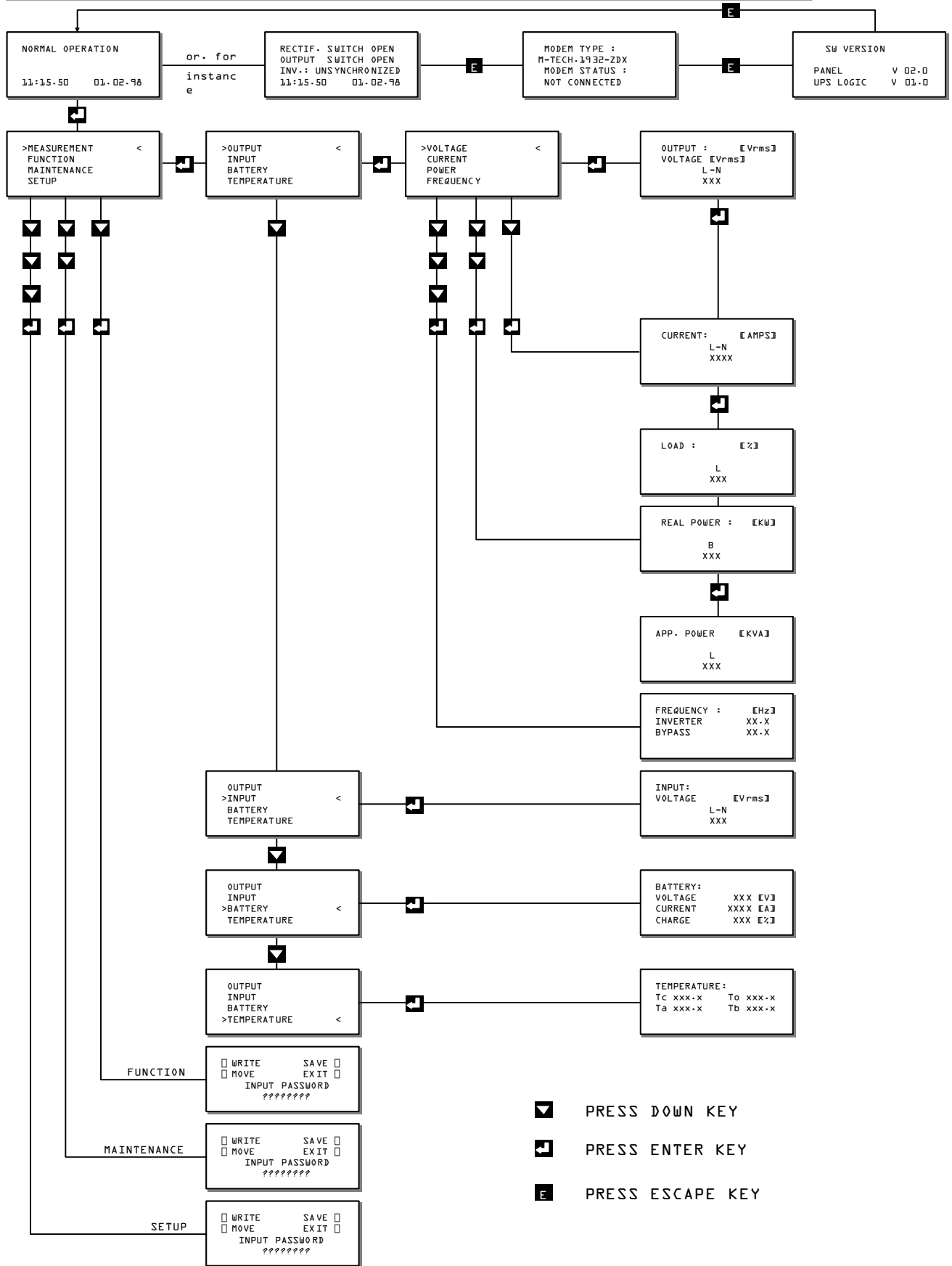

Fig 4 - 4: Map of screen display available to operator



### LCD Display Panel Messages

```
EMERSON NETWORK POWER
3PH-1PH
UPS
```

```
RECTIF. SWITCH OPEN
BATTERY SWITCH OPEN
OUTPUT SWITCH OPEN
hh.mm.ss dd.mm.yy
```

```
NORMAL OPERATION

hh.mm.ss dd.mm.yy
```

```
MODEM TYPE
M-TECH.1932-ZDX
MODEM STATUS
NOT CONNECTED
```

```
>MEASUREMENT <
FUNCTION
MAINTENANCE
SETUP
```

#### **Initializing Window**

After first connecting power to the UPS and closing the bypass A.C. input power switch, the INITIALIZATION message will appear on the LCD screen. It persists for about five seconds while the control firmware is loaded and the unit performs a self-test. It is followed by a window showing various messages with the time and date on the bottom line.

When the power switches and battery circuit breaker have been closed and the inverter has stabilized the window will change to the default window.

#### **Default Window**

The message shown below, will be seen on the default window whenever the UPS is operating normally.

The top lines display the UPS operational status and indicates alarm conditions when they occur; and line four normally shows the time and date.

#### **Info Window**

From Default Window, pressing the ESC key, information about the modem programmed in memory and its connection are shown on display.

Pressing again the ESC key, software release are shown, both on UPS board and on Panel board; this feature is useful upgrading SW for next versions and to know exactly features of present release.

Pressing again ESC key it goes back to Default Window.

#### **Main Menu Window**

The main menu is selected from the Default Window by pressing the ENTER key:

The four windows accessed from the Main Menu offer further options, which are described in the relevant chapters of this manual.

The MEASUREMENT option gives access to windows which show the present values of parameters such as input & output voltages and current, load, etc. These parameters are useful when determining the state of UPS or the cause of alarms, and are described in more detail below.

The FUNCTION, MAINTENANCE and SETUP options all require a password which is set by the commissioning engineer. This manual does not provide servicing instructions and the options accessed from these windows are therefore not shown on the menu map in figure 4-4. Only trained service engineers should be authorized with a password.

In any case FUNCTION, MAINTENANCE and SETUP options can be read but is not possible to change them without password.

***Option Selection Mode***

If a window from which options can be selected is displayed, a pair of indicator arrows appear at the extremities of the line.

The UP/ DOWN push buttons move these up and down the screen over the options. When the arrows point at a chosen option, press ENTER to display the next window. Press ESC to return the previous window to the screen.

***Alarm / Warning Messages***

The Alarm and Warning messages are shown on the three upper lines of the display. The ALARM indicator (red) and audible warning accompany all Alarm messages.

There is a default selection for every message and corresponding mode of red indicator (OFF, ON, FLASHING) and buzzer sound (OFF, ON INTERMITTENT, SINGLE SOUND)

The default mode can be changed according to particular needs of the plant, a PC and communication program are needed.

The Alarm and Warning messages are detailed in Chapter 7- Display Panel Interpretations of this manual.

## CHAPTER 5

# Operating Instructions

### 5.1 Introduction

The UPS can be considered to be in one of three operating conditions:

#### *Normal operation*

All relevant power switches and circuit breakers closed, the load is powered by the UPS.

#### *Shutdown*

All power switches and circuit breakers open - no load power.

#### *On Static Bypass*

The load power is supplied through the mains static bypass line. This may be considered as an intermediate operating condition being utilized for the purpose of load transfers between inverter and maintenance bypass or supply under abnormal operating conditions.

#### *ECOMODE*

All the relevant power supply switches and the battery switch are off, and the load is fed by the Bypass Mains through the UPS Static Transfer Switch, while the Inverter remains on stand-by.

This chapter contains instructions which enable you to switch between the three above conditions, to carry out a RESET after a fault transfer and how to switch OFF the inverter.

#### 5.1.1 General notes

**Note1:** *All the user controls and indicators mentioned in these procedures are identified in chapter 1. Some of diagrams are repeated here to assist in understanding the procedures.*

**Note2:** *The audible alarm may annunciate at various points in these procedures. It can be cancelled at any time by pressing the 'Alarm Reset' push-button.*

**Note3:** *The Hipulse UPS System incorporates an optional automatic boost charge facility which can be used in systems containing conventional flooded lead-acid batteries. If this type of battery is used in your installation you may notice that the battery charger voltage may be greater than its nominal (432V d.c. for 380V a.c., 446V d.c. for 400V a.c. and 459V d.c. for 415V a.c. system) when the mains supply returns from a prolonged outage. This is the normal response of the boost charge facility; the charger voltage should return to normal after a few hours.*

#### 5.1.2 Power Switches

The UPS can be separated by means of power switches, mounted inside the cabinet and accessible after opening the front door, which has a key.

The location of the UPS power switches is shown in Figure 5-1. The UPS module power switches are:

- Q1 - Input MCCB: connects the UPS with the mains supply.
- Q2 - Bypass Isolator: connects the UPS with the bypass supply.
- Q3 - Maintenance Bypass Isolator (Padlocked) permits supply of the load directly by the bypass line for maintenance of the UPS module.  
*The internal maintenance bypass must not be used when the UPS system is comprised of **more than two UPS** modules in parallel.*
- Q4 - Output Isolator: connects the output of the UPS to the load.

**Note:** *The battery interrupter is not expected inside of the UPS and should be installed in the proximity of the respective battery bank.*

## 5.2 Procedure for UPS Start-up: without interrupting power to the load

This procedure will describe how to start the UPS and the how to transfer the load from the external maintenance bypass to the UPS inverter. It is assumed that the installation is complete, the system has been commissioned by authorized personnel and the external power isolators are closed. Refer to Fig 5-1 for corresponding isolators Q1 to Q4, and Fig 5-2 Operator Control Panel for various LEDs and Display indications.

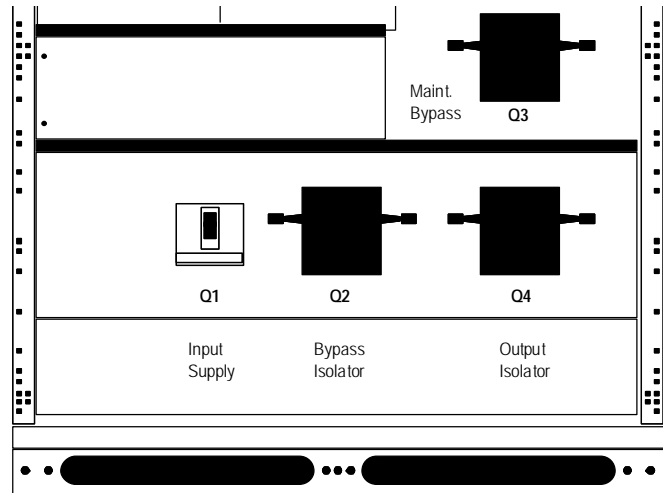

Fig 5 - 1: Location of Power Isolators

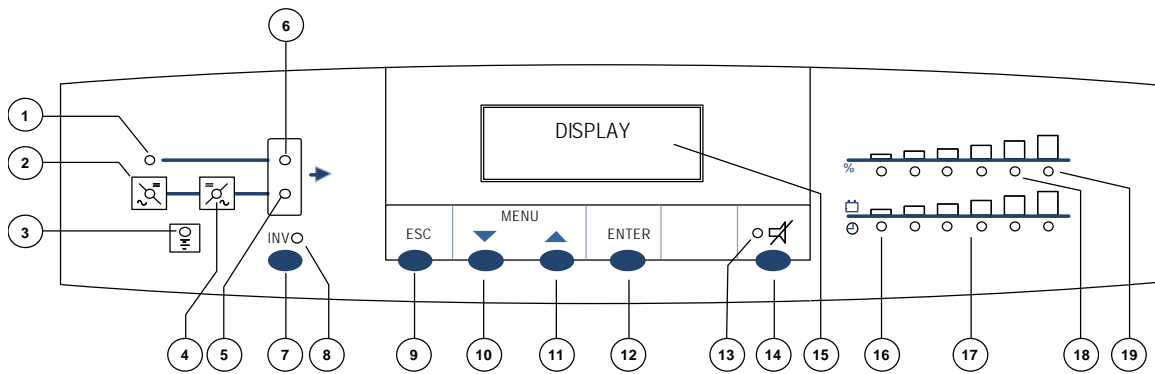

Fig 5 - 2: Operator Control Panel

ENSURE CORRECT PHASE ROTATION

1. Close Q3 Maintenance Bypass switch and external switch (inside Maintenance Bypass) to load.
2. Close the output power switch Q4 and the Bypass power switch Q2.

EMERSON NETWORK POWER  
 3PH-1PH  
 UPS

**Initializing Window:**  
 After first connecting power to the UPS and closing the isolator, this message will appear on the LCD screen. It persists for about five seconds while the control firmware is loaded by a screen showing various messages with the time and date on the bottom line.

The Module Mimic indicators Bypass supply healthy (1) and after 20 seconds Load on Bypass (6) will flash and red led (13) will illuminate.

```
RECTIF. SWITCH OPEN
BATTERY C.B. OPEN
MANUAL BYPASS CLOSED
hh.mm.ss      dd.mm.yy
```

```
LOAD ON BYPASS
MANUAL BYPASS CLOSED
INV. OFF
hh.mm.ss      dd.mm.yy
```

```
LOAD ON BYPASS
INV.: OFF
hh.mm.ss      dd.mm.yy
```

```
NORMAL OPERATION
hh.mm.ss      dd.mm.yy
```

```
NORMAL OPERATION
(ECOMODE)
hh.mm.ss      dd.mm.yy
```

The Display window will show the present status of the UPS

3. Close the Rectifier input power switch Q1.

**Note:**

*In ECOMODE the message 'LOAD ON BYPASS' will not appear.*

4. Wait for 20 seconds then close the battery circuit breaker. This is located inside the battery cabinet (if used) or is otherwise located adjacent to the battery racks.

The Module Mimic indicator (3) Battery unavailable should extinguish. Several LED's on the Battery state of charge bargraph will illuminate showing the battery state of charge.

The rectifier will 'walk-in' and stabilize at float the voltage.

5. Open the Maintenance Bypass power switch Q3 and fit lock.

The Module mimic indicator Load on bypass (6) will flash amber.

The Display window will show the present status of the UPS.

6. After 5 seconds the Module Mimic LED's will change so that the Load on inverter (5) will light steady green and the Load on Bypass (6) will extinguish.

*Note: In ECOMODE the Load on Mains led (6) stays on while the Load on inverter led (5) is off.*

The message shown below, will be seen on the Default screen whenever the UPS is operating normally.

***The UPS is operating normally with its Inverter supplying the load***

ECOMODE: The following message will appear in the default screen whenever the UPS is operating on ECOMODE. The load is supplied by the Bypass Mains.

***The UPS is operating in ECOMODE with the Bypass Mains supplying the load.***

### 5.3 Procedure for UPS Startup without power initially supplied to the load

This procedure should be followed when turning on the UPS from fully powered down condition i.e. where the load is not being initially supplied at all. It is assumed that the installation is complete, the system has been commissioned by authorized personnel and the external power isolators are closed. Refer to Fig 5-1 & 5-2 for corresponding isolators Q1 to Q4, and Operator control Panel respectively.

1. Open the UPS doors to gain access to the main power switches.

2. Close the Rectifier Power Switch (Q1).  
The Module Mimic LED's will indicate input supply a.c. present (2 -steady green) and after approximately 20 seconds the Inverter output healthy (4- steady green) and Battery unavailable (3) will light and also red led (13) will illuminate.

The Display screen will show the following:

```
EMERSON NETWORK POWER
3PH-1PH
UPS
```

```
BYPASS SWITCH OPEN
BATTERY C.B. OPEN
OUTPUT SWITCH OPEN
hh.mm.ss dd.mm.yy
```

#### **Initializing Window:**

After first connecting power to the UPS and closing the Q1 isolator, this message will appear on the LCD screen. It persists for about five seconds while the control firmware is loaded. It is followed by a screen showing various messages with the time and date on the bottom line.

*Note: If input power is present but the display remains blank, then the Micro Controller is not working, please contact your dealer for advice.*

#### **WARNING**

The following action will apply power to load the equipment - Ensure that it is safe do so

3. Close the UPS output power switch Q4.  
The Module Mimic LED's will change so that the Load on Inverter (5 - steady green) and Battery unavailable (3) will light and also red led (13) will illuminate.

*Note: In ECOMODE the Load on Inverter led (5) is off.*

This display window will show:

```
BATTERY C.B. OPEN
BYPASS SWITCH OPEN
hh.mm.ss dd.mm.yy
```

```
BATTERY C.B. OPEN
hh.mm.ss dd.mm.yy
```

4. Close the Bypass input power switch Q2.  
Bypass input led (1-steady green) will light, after 20 seconds the inverter synchronises with the mains bypass.

5. Before closing the battery circuit breaker check the d.c. busbar voltage. From the above window press the ENTER key:

The Main Menu Window will display:

```
>MEASUREMENT      <
  FUNCTION
  MAINTENANCE
  SETUP
```

Select MEASUREMENT and press ENTER key.

```
  OUTPUT
  INPUT
>BATTERY           <
  TEMPERATURE
```

Select BATTERY and d.c. busbar voltage will be displayed:

```
BATTERY
VOLTAGE      446 [V]
CURRENT      001 [A]
CHARGE       000 [%]
```

If the voltage indicated is satisfactory (432V d.c. for 380V a.c. system, 446VV d.c. for 400V a.c. system and 459V d.c. for a 415V a.c. system) press the Escape key repeatedly until the display returns to the original window.

6. Manually close the battery circuit breaker. This is located inside the battery cabinet (if used) or is otherwise located adjacent to the battery racks.

The Module Mimic indicator (3) Battery unavailable should extinguish. Several LED's on the Battery state of charge bargraph (17) will illuminate showing the battery state of charge

When the battery circuit breaker has been closed and the inverter has stabilized the screen will change to the default window.

**Default window:**

The message shown below, will be seen on the default screen whenever the UPS is operating normally:

```
NORMAL OPERATION

hh.mm.ss      dd.mm.yy
```

The top lines display the UPS operational status and indicates alarm conditions when they occur; and line four normally shows the time and date.

***The UPS is operating normally with its Inverter supplying the load.***

**ECOMODE:**

The following message will appear in the default screen whenever the UPS is operating in ECOMODE. The load is supplied through Bypass Mains.

```
NORMAL OPERATION
(ECOMODE)

hh.mm.ss      dd.mm.yy
```

***The UPS is operating in ECOMODE with the Bypass Mains supplying the load.***

## 5.4 Procedure for Switching the UPS into a Maintenance Bypass condition from normal operation

The first part of this procedure details how to select the Inverter OFF and power the load from the bypass mains via the Static Switch. This procedure should be followed to transfer the load from the UPS inverter output to the maintenance bypass system. This may be required during UPS maintenance procedures.

### NORMAL OPERATION:

Follow the procedure below to transfer the load from the output to the Maintenance Bypass of UPS.

### ECOMODE:

Follow the procedure below to transfer the load from the output Maintenance Bypass of the UPS.

### CAUTION

The following window allows the operator to select the UPS inverter ON or OFF

Before making this operation, read messages on display to be sure that bypass supply is regular and the inverter is synchronous with it, not to risk a short interruption in powering the load.

IF YOU ARE NOT SURE OF WHAT YOU ARE DOING  
- THEN DO NOT DO IT

```
WARNING! STOP
INVERTER REQUESTED
ENTER TO CONTINUE ↵
ESC TO CANCEL
```

1. Press the INV switch on the left side of the operator control panel.

2. Confirm this operation as instructed at the display:

Press ENTER for 1 second to confirm INV OFF  
Press ESC for 1 second.

3. If ENTER is pressed:

The Module Mimic indicator Load on Inverter (5) will extinguish and the Load on Bypass indicator (6) will flash amber, and also the red led (13) will flash and normally will be accompanied by an audible alarm.

Pressing the Alarm Silence Switch cancels the audible alarm but leaves the warning message displayed until the appropriate condition is rectified.

4a) NORMAL OPERATION:

The UPS inverter will not shut down and the load will transfer to the Bypass supply. The Module Mimic indicator Load on Bypass (6) will flash amber and the Load on Inverter (5) indicator will extinguish.

*Your load is now powered via the Static Bypass system.*

4b) ECOMODE:



At this point the UPS inverter stops but the load continues to be supplied by the bypass mains. The Load on Mains indicator light (6) on the unit's synoptic panel flashes yellow, and the Load on Inverter indicator light (5) goes off.

***Your load is now powered via the Static Bypass system***

5. Unfasten the lock, release the internal safety bar and close the maintenance bypass power switch Q3. Open the Rectifier input power switch Q1, the Output power switch Q4, the bypass power switch Q2 and the Battery circuit breaker. This is located inside the battery cabinet (if used) or is otherwise located adjacent to the battery racks. The unit will power down but the load will continue to be supplied by the manual bypass.

**WARNING**

Wait 5 minutes for the internal D.C. busbar capacitors to discharge.

**WARNING**

The following points will be live within the UPS:

- Bypass a.c. input supply terminals.
- Maintenance Bypass power switch.
- Static Bypass power switch.
- UPS output terminals.

Input and Output terminals remain protected by a metallic cover.

***Your load is now powered from the maintenance bypass system and the UPS is completely shut down.***

## 5.5 Procedure for Switching the UPS ON from a Maintenance Power condition.

Follow the procedure for 'UPS startup: without interrupting power to the load' referring to the paragraph 5.2, start from point number 2.

## 5.6 Procedure for completely powering down the UPS

This procedure should be followed to completely power down the UPS and LOAD. All power switches, isolators and circuit breakers will be opened and there will be no load power.

### CAUTION

The following procedure will switch off all power to the load equipment.

1. Open the Battery circuit breaker and the Rectifier input power switch Q1.

The Module Mimic indicator Load on Inverter (5) will extinguish and the Load on Bypass indicator (6) will flash amber. The Battery not available indicator (3) will light amber and the battery bargraph LED's will all extinguish.

The display window will show messages reflecting the actions taken (i.e. Load on Bypass; Battery Breaker open; Rect. Switch open; etc).

*Note: In ECOMODE the message 'LOAD ON BYPASS' will not appear.*

2. Open the Output power switch Q4 and the bypass power switch Q2.

All operator LED indications and messages will extinguish as the mains driven internal power supplies decay.

3. To completely isolate the UPS from the a.c. supplies, the main external power input isolator (both isolators, where separate supplies are provided for rectifier and bypass) should be opened.

*On the primary input distribution panel, which is often located distant from the UPS area, a label should be posted advising service personnel that the UPS circuit is under maintenance.*

```
LOAD ON BYPASS
BATTERY C.B. OPEN
RECTIF. SWITCH OPEN
hh.mm.ss      dd.mm.yy
```

**WARNING**

Wait 5 minutes for the internal D.C. busbar capacitors to discharge.

*The UPS is now completely powered down.*

**IMPORTANT**

The Maintenance Bypass Power switch may be operated at any time when the UPS is powered down to connect the load to the maintenance bypass supply if required.

The load equipment is not protected from normal supply aberrations when operating in the maintenance bypass mode.

### 5.7 Procedure for carrying out a RESET after a recognized controlled transfer to bypass or EPO action.

When the necessary action to correct the problem has been taken, this procedure should be followed to restore the UPS back to its normal operating condition following a controlled transfer to bypass or when the Remote Emergency Power Off has been activated.

A recognized controlled transfer to bypass is activated by the following problems: Inverter Overtemperature, Cut-off Overload, Battery Over voltage, when configured for manual return from bypass operation (only for system test).

```
EMERGENCY STOP
LOAD ON BYPASS
INV: UNSYNCHRONISED
hh.mm.ss dd.mm.yy
```

Press the ENTER key.

*Note: In ECOMODE the message 'LOAD ON BYPASS' will not appear.*

```
MEASUREMENT
>FUNCTION <
MAINTENANCE
SETUP
```

Select FUNCTION and press ENTER key.

```
↑WRITE SAVE ↓
↓MOVE EXIT ESC
ENTER PASSWORD
00000000
```

When the PASSWORD has been completed press ENTER key.

```
BATTERY TEST
GENERATOR
PANEL SETUP
>NEXT PAGE      <
```

Select NEXT PAGE and press ENTER key.

```
PROTOCOLS
ON/OFF UPS CONTROLS
RELOAD UPS DATA
>RESET BUFFERS  <
```

Press the ENTER key.

```
RESET ALARM HISTORY
RESET EVENT HISTORY
RECTIFIER OFF
>RESET ALARMS   <
```

Select RESET ALARMS and press ENTER key.

Return the Display window to normal by repeatedly pressing the ESCAPE key back through the various windows until the default screen is displayed.

These operations resets the logic circuitry to enable the rectifier, inverter and static switch to operate normally.

*Note:* When the remote EPO switch has been activated it is necessary to manually close the battery circuit breaker.

#### CAUTION

When the EPO system incorporates a trip facility of the external input a.c. power supply circuit breaker, the RESET switch would have no affect on it. First close the external input a.c. supply circuit breaker, the UPS can be started in the normal manner, as the logic circuits will automatically reset on return of the power supplies.

## 5.8 Adding a single module to an existing system

This procedure should be carried out only by trained service personal.

## 5.9 Procedure to completely switch ON/ OFF the UPS at the UPS Display Control Panel :

```
MEASUREMENT
>FUNCTION      <
MAINTENANCE
SETUP
```

```
↑WRITE      SAVE  ↓
↓MOVE      EXIT ESC
ENTER PASSWORD
      00000000
```

```
BATTERY TEST
GENERATOR
PANEL SETUP
>NEXT PAGE      <
```

```
MODEM CONNECTION
>ON/OFF UPS CONTROL <
RELOAD UPS DATA
RESET BUFFERS
```

```
>INVERTER OFF      <
BYPASS             ON
RECTIFIER          ON
RECTIFIER          MAN
```

```
↑ROTATE      START  ↓
              EXIT  ESC
INVERTER          ON
```

1. From the Default window, press the ENTER key: the Main Menu window will display:

2. Select FUNCTION and press ENTER key:

Before being allowed into the FUNCTION windows you are requested to enter a password. This is achieved by pressing the UP arrow key repeatedly until the first digit displays the character required, you then press the DOWN arrow key once to move on to the second digit. This action is repeated for all eight digits. When the PASSWORD has been completed press the ENTER key.

### CAUTION

This operation gives the operator access to modify UPS's operating mode, it is advised that only trained qualified personnel should attempt to do that.

3. You have now access to all function windows.

Press the DOWN arrow key until the cursors have selected NEXT PAGE – press the enter key.

4. Press the DOWN arrow key until the cursors have selected ON/OFF UPS CONTROL.

Press the enter key.

### CAUTION

The following window allows the operator to select the UPS inverter ON or OFF, select the rectifier ON or OFF, select the rectifier to manual or float voltage and a switch OFF the line (bypass) voltage to the load.

IF YOU ARE NOT SURE WHAT YOU ARE DOING,  
THEN DO NOT DO IT.

NORMAL OPERATION:

5a. Ensure INVERTER is selected by the cursors and press the ENTER key.

The OFF selection will be highlighted, using the UP arrow key, rotate between the selections offered (in this case it will be ON or OFF) select ON. Press the ENTER key to execute your order.

After approximately 20 seconds, the Module Mimic will change so that the Load on Inverter (5) will light steady green and the Load on Bypass (6) will extinguish.

6a. Return the Display window to normal by repeatedly pressing ESCAPE key back through the various windows until the default screen is displayed.

***The UPS is operating normally with its Inverter supplying the load.***

```
>INVERTER OFF      <
  BYPASS           0N
  RECTIFIER        0N
  RECTIFIER        MAN
```

```
↑ROTATE   START  ↓
           EXIT  ESC
  INVERTER           0N
```

ECOMODE:

5b. Ensure BYPASS is selected by the cursor and press the ENTER key:

The OFF selection will be highlighted, using the UP arrow key, rotate between the selection offered (in this case it will be On or OFF) Select ON. Press the ENTER key to execute your order.

The Module Mimic LED's will change: Load on Mains (6) will come on and Load on Inverter (5) will go out.

6b. Return the Display window to normal by repeatedly pressing ESCAPE key back through the various windows until the default screen is displayed.

***The UPS is operating in ECOMODE with Bypass Mains supplying the load.***

## 5.10 Procedure to switch ON/OFF the inverter at UPS display control panel

### CAUTION

This operation gives the operator access to modify UPS's operating mode, it is advised that only trained qualified personnel should attempt to do that.

```
NORMAL OPERATION  
  
hh.mm.ss    dd.mm.yy
```

The display window will show the present status of the UPS for normal operation.

```
NORMAL OPERATION  
(ECOMODE)  
  
hh.mm.ss    dd.mm.yy
```

The display window will show the following screen for the UPS running in ECOMODE.

```
WARNING! STOP  
INVERTER REQUESTED  
ENTER TO CONTINUE ↵  
ESC TO CANCEL
```

1.Press the INV switch on the left side of the operator control panel.

2.Confirm this operation as instructed at the display:

Press ENTER for 1 second to confirm INV OFF  
Press ESCAPE for 1 second to exit.

```
INV OFF VIA DISPLAY  
LOAD ON BYPASS  
  
hh.mm.ss    dd.mm.yy
```

3.If ENTER is pressed:

The Module Mimic indicator Load on Inverter (5) will extinguish and the load on bypass indicator (6) will flash amber, and also the red led (13) will light and normally will be accompanied by audible alarm. Pressing the Alarm Silence Switch cancels the audible alarm. Pressing the Alarm Silence Switch cancels the audible, but leaves the warning message displayed until the appropriate condition is rectified.

*Note: In ECOMODE the message 'LOAD ON BYPASS' will not appear.*

4.Press the INV switch on the operator control panel to start up the INVERTER.

```
NORMAL OPERATION  
  
hh.mm.ss    dd.mm.yy
```

NORMAL OPERATION

After 20 second the Module Mimic LEDS will change so that the local or the inverter (5) will light steady green and the load on bypass (6) will extinguish.

Return to the normal window.

```
NORMAL OPERATION  
(ECOMODE)  
  
hh.mm.ss    dd.mm.yy
```

ECOMODE:

The load on Mimic led (6) stays on while the load on inverter led (5) will illuminate.

ECOMODE: The following message will appear in the default screen whenever the UPS is operating in ECOMODE. The load is supplied by the bypass mains.

## 5.11 Setting the Battery Test

A software-controlled battery facility can be initiated from the Operator control Panel on an 'immediate' or 'periodic' basis. This test turns off the rectifier and runs the inverter (and load) from the battery from the predetermined period. If the battery voltage falls below an preset minimum level prior to the termination of the test period a 'BATTERY TEST FAILED' alarm is annunciated and the rectifier is immediately turned on to prevent the load from transferring to bypass – and recharge the battery. These instructions given below initiates an immediate battery test.

For the following test to be 'meaningful' as part of the UPS commissioning procedure, the batteries should be fully charges prior to the test being carried out. The UPS rectifier section must be therefore allowed to be operated with the battery connected for several hours to provide the battery with an adequate initial charge.

### CAUTION

Do not continue with this procedure if the battery is not yet charged.

1. From the default window press the ENTER key: the Main Menu window will display.
2. Select FUNCTION and press ENTER key.
3. When the password has been completed press the ENTER key.
4. Select the BATTERY TEST and press ENTER key.
5. Verify that the parameters entered in the battery test set up menu are appropriate. If not then enter the correct set up parameters (FUNCTION → BATTERY TEST → SET UP)
6. Press ESC key to return to the *battery test menu screen*.
7. Using the 'UP' menu button, select 'YES' (Y), then press enter to initiate an immediate battery test.
8. Step back to default screen, by continuously pressing the ESC button and verify that the message: BATTERY UNDER TEST is displayed. The green LED battery bargraph will indicate the remaining battery time.  
*Note: If the UPS is allowed to run in this condition the battery bargraph LED's will progressively turn off the indicating the remaining autonomy time.*
9. The battery will be tested for the selected 'DURATION' time after which the UPS will revert to normal operation.  
*Note: If the battery fails the test, the rectifier will immediately return to the float mode and the 'BATTERY: TEST FAILED' alarm will be displayed on the default screen.*



## 5.12 Language Selection :

If required, select the appropriate language using the following procedure.

```
MEASUREMENT
>FUNCTION      <
MAINTENANCE
SETUP
```

From 'Default' window, press ENTER key.

Select the FUNCTION and press the enter key.

```
↑WRITE      SAVE  ↓
↓MOVE      EXIT  ESC
ENTER PASSWORD
00000000
```

A password must be entered to gain a further access to next menu. The initial default password of '00000000' need not be changed at this point of time. Press the enter key.

```
BATTERY TEST
GENERATOR
>PANEL SETUP  <
NEXT PAGE
```

Select PANEL SET UP and press enter key.

```
>LANGUAGE    ENG  <
TYPE 0000    MASTER
GROUP ↓      UPS ↓
PASSWORD 00000000
```

Select LANGUAGE and press the ENTER key.

Use the UP push button to rotate through the available options and select the required default language. The options are: English, Italian, German, French , Dutch & Spanish.

Press ENTER to accept and store the language selection, then step back to the default window by repeatedly pressing ESC as required; the current alarms should now be stored in the selected language.

**Note:** Ensure the data entered during the following procedures are recorded in the appropriate commissioning documentation.

## 5.13 Changing the current Date and Time

1. From DEFAULT WINDOW, pressing ENTER key, select MAINTENANCE >> ENTER>> PASSWORD>> ENTER>> select and enter the line showing the time and date.
2. Position the cursor on the row on which the date-time is displayed, and press ENTER.
3. Using the 'UP' and 'DOWN' menu buttons, enter the current time and date information.
4. Press ENTER to save the settings, then press ESC twice to return to the DEFAULT WINDOW.



# Battery Installation

## 6.1 Introduction

The UPS battery consists of battery blocks connected in series to provide a nominal d.c. input voltage for the UPS inverter. The required 'Autonomy time' (the time that battery can maintain supply to the load in the event of a mains failure) is limited by the ampere hour size of the individual battery blocks and in some cases it could mean several strings are connected in parallel.

Usually, with UPS installations in the power range covered by the 'Hipulse' equipment, the batteries are contained in a purpose built battery cabinet which sits alongside the main UPS and the Battery Circuit Breaker Controller Board (for all sizes).

The battery cabinet can be installed in one of the following forms:

*Complete installation comprising the battery cabinet, batteries and the circuit breaker.*

*Battery cabinets and battery circuit breaker - with no batteries.*

*Battery cabinet only - with no batteries or circuit breaker.*

It is possible to install batteries of various types and capacity in the cabinet to obtain the required autonomy characteristics.

It must be possible to disconnect the battery from the UPS module when undertaking maintenance or service procedures. This is facilitated by means of a suitably rated circuit breaker which must be located as close as possible to the battery terminals, and the power and control cables connected to the UPS using the most direct route possible. The circuit breaker can be switched off manually ON or OFF, but should also contain an under voltage release mechanism (to be energized by the UPS control electronics) and a magnetic trip facility for overload protection which is used in conjunction with battery circuit breaker controller module.

If multiple sets of batteries connected in parallel are used to increase battery autonomy, the extension must be fitted with a sectioning device to permit work to be performed on one set of batteries while the others remain in service.

For external battery assembly, a customized Battery Circuit Breaker (the features of which depend on the sizes of the UPS) including a Battery Circuit Controller Board (the same for all sizes) can be provided. This box is designed to be either wall mounted or assembled on a frame, and is connected between the UPS and the battery. Refer to section 6.9 for more information.

A common battery circuit breaker is available for systems incorporating two parallel UPS with a common battery. It comprises two switches, which may be used to section one UPS while the other remains active. Refer to section 8.3 for more information.

## 6.2 Safety

Special care should be taken while working on batteries associated with Hi-pulse UPS system equipment. When all the cells are connected together, the battery terminal voltage will exceed 400 V DC and is potentially lethal. A primary safety consideration is to physically isolate the battery installation from all but appropriately qualified maintenance personnel, which is best achieved by locating in a key locatable cabinet or a purpose designed, dedicated battery room.

The following general battery safety precautions and WARNINGS should be observed all the time.

#### CAUTION

- A battery can present risk of electric shock or burn from high short circuit currents.
- When connected in a string the voltage could be 460 V d.c. this voltage is potentially lethal always observe high voltage precautions.
- Only qualified personnel should install or service batteries.
- Eye protection should be worn to prevent from accidental electrical arcs.
- Only use tools with insulated handles.
- Wear rubber gloves and a rubber apron when handling batteries.
- If a battery leaks electrolyte, or is otherwise physically damaged, it should be placed in a container resistant to sulphuric acid and disposed of in accordance with legal regulations.
- If electrolyte comes into contact with the skin the affected area should be washed with plenty of clean water immediately.
- Batteries must be always disposed of according to local environmental laws.

### 6.3 UPS Batteries

It is common practice in UPS installations to use valve-regulated cells. The term 'valve regulated' is used currently in place of either 'sealed' or maintenance free both of which have been used in the past.

Valve regulated cells are not 'sealed' and will vent, particularly on overcharge. The amount of gas given off is less than for a flooded cell but when considering the design of the battery installation allowances must be made for adequate ventilation and heating of the cells. Boost charging must not be applied to valve regulated cells, as this will cause them to overcharge and subsequently vent.

Similarly, valve regulated cells cannot be regarded as 'maintenance free' as they must be kept clean and their connections checked periodically for tightness and lack of corrosion. It is not possible to check the cells' specific gravity directly but the battery can be checked by the 'CS PG battery service programme', which can give an indication of faulty cell degradation within the battery.

Batteries are fully charged before delivery, however, storage and transportation times mean that, inevitably, some charge is lost by the time the battery is commissioned. All the cells forming the battery should be brought to the same state of charge and recharged within 6 months of the factory charge.

It is especially important that the battery is fully charged before attempting a witness test of the autonomy time. This may require several days to complete; therefore, any witness test concerning the batteries should take place only after the battery has been on uninterrupted float charge for at least one week.

Cell performance typically improves after a few weeks in service or after two or three discharge / recharge cycles.

## 6.4 Installation design considerations

**Note:** Full safety instructions concerning the use and maintenance of UPS batteries are provided in the appropriate battery manufacturers' manuals. The battery safety information contained in this section relates to the key considerations, which must be taken into account during the installation design process and might affect the design outcome depending on localized conditions.

## 6.5 Battery installation and maintenance

### 6.5.1 Temperature considerations

Battery performance depends on the ambient battery temperature. Capacity and autonomy are quoted for a new battery operating at 20° C. Battery capacity is increased by 1% for every 1° C increase in temperature up to 25° C. If a battery is used at a temperature above 25° C, its life is reduced; consequently, its capacity and UPS autonomy time will reduce more rapidly over a period of time. Operating below 20° C will reduce the battery capacity by approximately 1% -1.5% per 1° C. For example if a battery discharge test is attempted during the middle of winter when the ambient temperature is 5° C the battery capacity will be only 77.5% of its design value and will not satisfy its specified autonomy time.

Ambient temperature, ventilation, spacing, float voltage and ripple current all affect the battery temperature. Uneven temperature distribution through the battery string will cause the voltage distribution to be uneven which can also lead to problems- it is therefore very important to maintain an even temperature across the whole battery chain. 'Valve regulated' cells are very sensitive to temperature and should be operated at a temperature between 15° C and 25° C. To help sustain this operating temperature range the battery is normally float charged at 2.25V/cell. When batteries are cabinet mounted adjacent to the UPS module, it is the battery which dictates the designed maximum ambient temperature, not the UPS.- i.e. in the case of 'valve regulated' cells the ambient regulated cells the ambient room temperature should be kept between 15°C and 25°C, and not between 0°C and 40°C (which is the specified main equipment operating temperature range) Temperature excursions are permissible for short periods of time provided the ambient temperature does not exceed 25°C.

### 6.5.2 Battery population

The nominal DC bus voltage, and therefore battery float voltage, is set according to the module's rated input/output voltage and usually set top 432Vdc (380Vac) 446 Vdc (440Vac) or 459Vdc (415Vac). Given that the desired cell float voltage is 2.25V, this means that a different number of cells are required in each case. (See Table 6-1).

Parameter	380V	400V	415V
Number of cells used (Standard)	192	198	204
End-of-discharge voltage	320	330	340
Float voltage	432	446	459

Table 6-1 – Battery population

## 6.6 Battery protection

The battery is connected to the UPS through a circuit breaker which is manually closed and electronically tripped via the UPS control circuitry. If the cells are cabinet mounted this circuit breaker is fitted within the cabinet, however, if they are rack mounted (or located remote from the main UPS cabinet) then the battery circuit breaker must be mounted as near as possible to the batteries themselves, and the power and control cables connected to the UPS using the most direct route possible. The UPS electronic circuitry will trip the circuit breaker if any of the following conditions occur:-

1. If the d.c. busbar drops below 330Vd.c. (this would normally occur during a mains failure when the battery autonomy time has been exceeded).
2. If there is a rectifier problem and the d.c. bus rises above (2.45 V/cell exceeded on the battery).
3. If the emergency stop is operated.

To achieve the required autonomy time, it may be necessary to parallel the battery strings. In which case, the battery circuit breaker should be placed downstream of all parallel battery strings.

*Note: All equipment servicing procedures should be carried out by trained personnel only.*

## 6.7 Battery Racks

### 6.7.1 Introduction

These are custom build fabricated racks for keeping the batteries. These are similar in construction to Battery cabinets except for the external covers. There are no covers and batteries are allowed to cool naturally.

### 6.7.2 Fitting the Batteries

1. In general, a minimum space of 10 mm must be left on all vertical sides of the battery block to permit free air movement around cells.
2. Clearance should be allowed between the top of the cells and the underside of the shelf above (this is necessary for monitoring and servicing cells).
3. When installing the batteries, please always work from the bottom shelf upwards to prevent raining the center of gravity.

### 6.7.3 Connecting the Battery

1. All the cabinets/ racks must be earthed and bonded together.
2. When the cabinet/ rack is installed on a raised floor, the battery power cables and circuit breaker control cables can be routed to the UPS cabinet via the floor of the cabinets. If the cabinets are located adjacent to each other located on a solid floor these cables can be passed between the cabinets via the lifting apertures located in the lower sides of the cabinets
3. In general, it is recommended that the inter-connecting cables are fitted to the batteries within their particular level before fitting the inter-level connecting cables, followed finally by the cables to the circuit breakers.
4. An insulating shroud should be fitted cables, followed finally by the cables to the circuit-breaker.
5. When connecting the cables between the battery extremities to the circuit breaker always connect the circuit breaker end of the cable first .

The battery cabinet also indicates the power and auxiliary connection cables (3 meters in length) between the cabinet and the UPS. Refer to section 3.3.1 to identify connections.

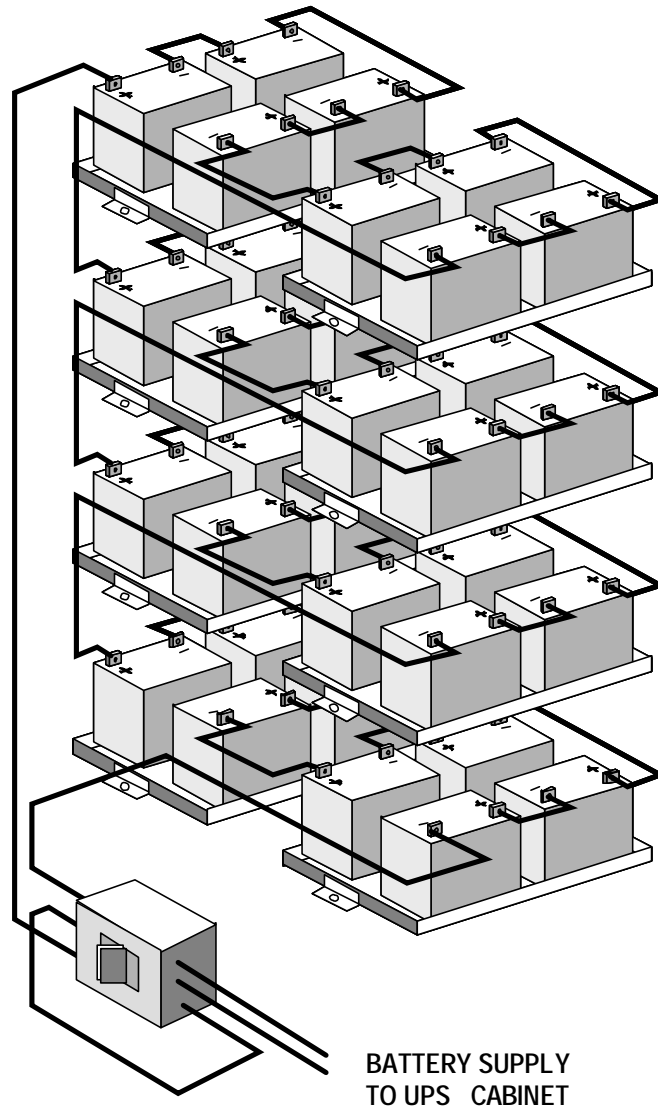

Figure 6-1: A typical arrangement of Batteries in a Battery Rack

## 6.8 Battery Installation

Whatever the type of mounting system selected, following conditions should be noted:

### **Layout of the cells:**

Whatever battery mounting system is used, the batteries should be laid out in such a manner as to make simultaneous contact with two exposed live parts having a potential greater than 150V impossible. Where this is not possible, insulated terminal shields must be installed and insulated cable must be used for connection.

### **Service platform:**

The service platform (or duckboard) must be slip-proof, insulated from the floor and be at least one meter wide.

### **Connections:**

All connections must be as short as possible.

### **Battery Protection Circuit Breaker:**

A battery circuit breaker is generally installed in an enclosure of the wall close to the battery installation. The connection of the circuit breaker box available for the Hipulse is described in the following paragraph.

## 6.9 Battery circuit breaker:

The Battery circuit breaker is fitted inside the Input Transformer cubical along with its control board and is used to connect the battery to the UPS in installations where the batteries are not contained in the standard battery cabinet.

Usually the breaker is fitted as close as possible to the batteries. Figure 6-3 shows details of the power and control cable connections between the circuit breaker or battery cabinet and the UPS itself. Two methods of connecting the three pole battery circuit breaker are illustrated in figure 6-2. Method A shows the spare pole being used to divide the battery bank in half, thereby reducing the battery total voltage to half when the circuit breaker is open during servicing etc. Method B connects the spare pole in series with the positive connection, thereby providing two sets of contacts in the positive line as an added safety precaution.

When installing the battery cabinet remove the battery fuse in the UPS before making the battery circuit breaker power connections.

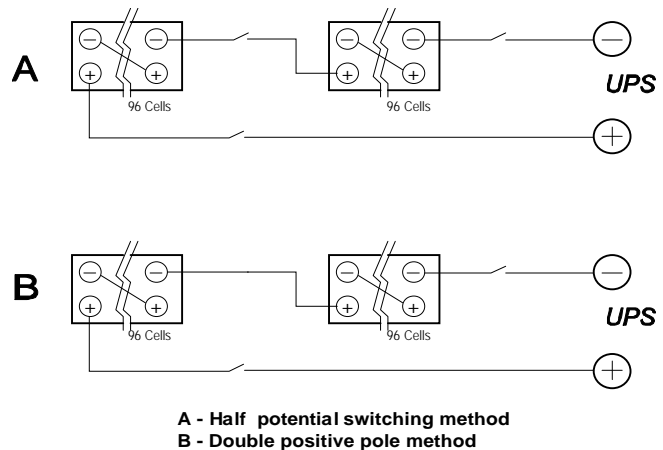

Figure 6-2: Battery C/B layout of switching poles



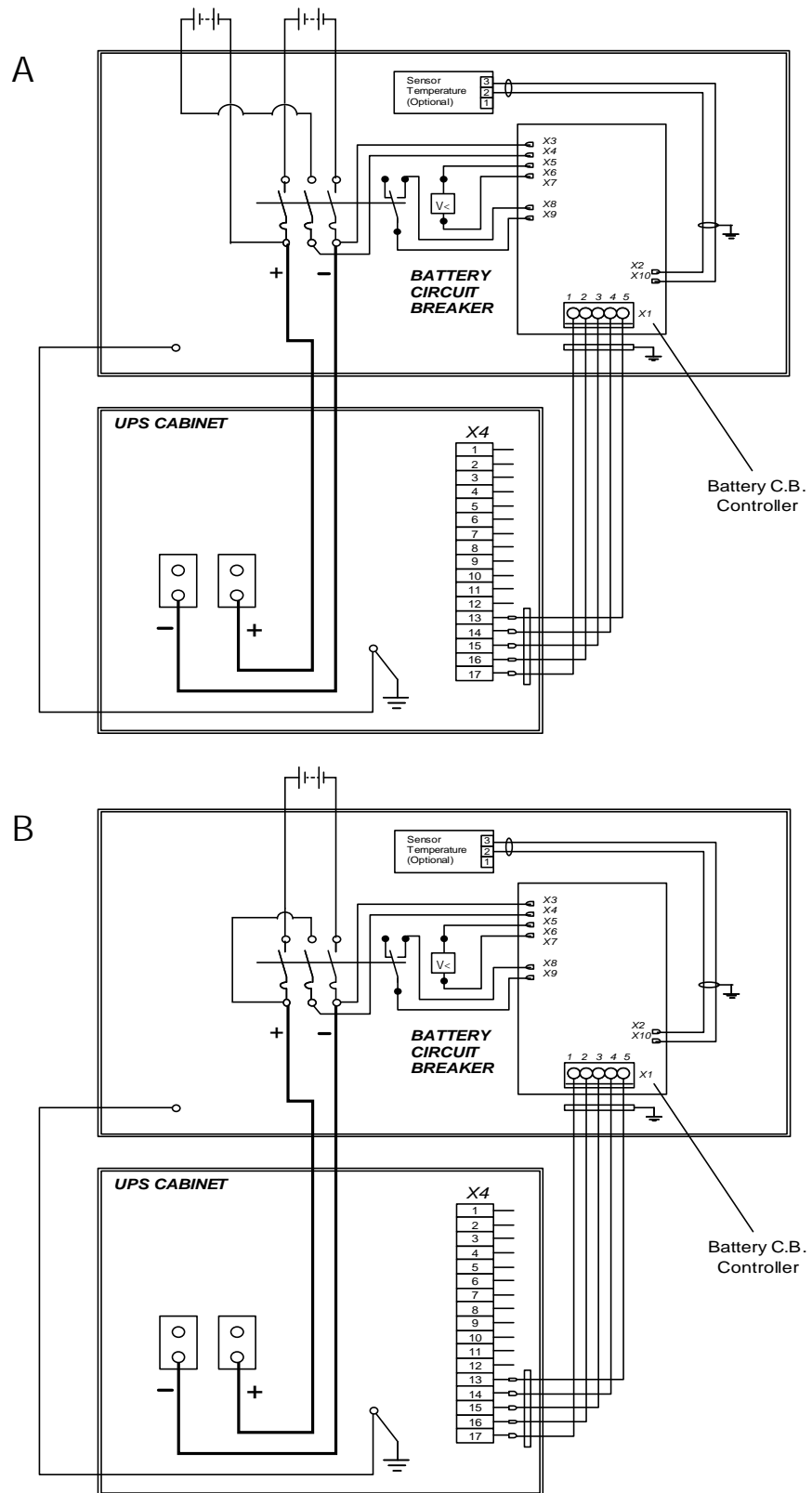

Figure 6-3: Battery Control and Power Connections  
A – Half potential switching method  
B – Double positive pole method

## 6.10 Battery temperature Board

A battery / sensor card supplied separately from the battery circuit breaker is connected with the UPS logic through the battery circuit breaker card.

With this feature fitted, the nominal float voltage supplied to the battery is adjusted so as to be inversely proportional to the ambient battery cabinet /room temperature. This prevents the battery being over charged at high ambient.

# Display Panel Interpretation

## 7.1 LED Interpretation:

The LED item number refers to details shown in the figure 7.1 below.

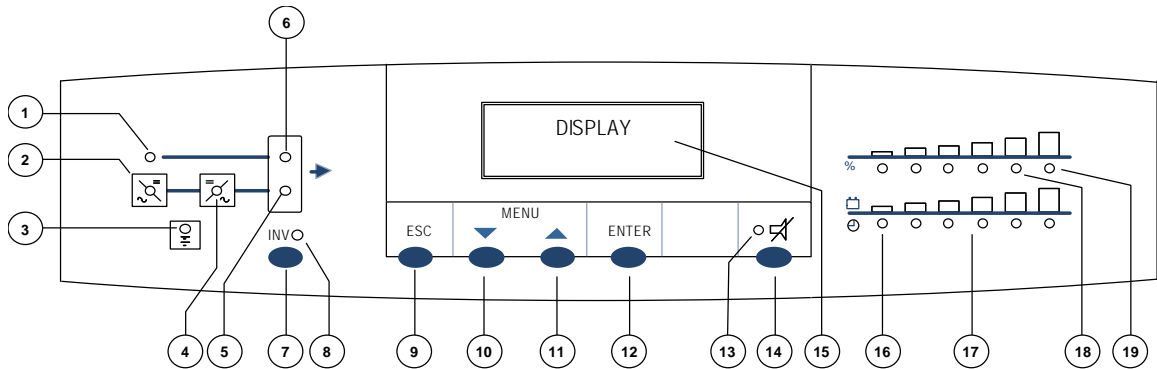

Fig 7-1: Single module operator control panel

LED NO.	NORMAL STATE	INTERPRETATION – ACTION
1.	ON	<p>If this green led is OFF, it signifies a problem with the Bypass input a.c.</p> <p>Check the following –</p> <ol style="list-style-type: none"> <li>1. Bypass input power switch Q2 is closed.</li> <li>2. Input Supply voltage is within 10% of nominal</li> <li>3. Power supply fuses are OK – on the a.c. Power supply board will extinguish if either fuse is ruptured.</li> </ol> <p>If the above checks prove unsatisfactory then seek qualified assistance.</p>
2.	ON	<p>If this led is OFF, a problem exists in the Input power supply or in a part of the rectifier. An alarm message is visible at the display.</p> <p>Check the following –</p> <ol style="list-style-type: none"> <li>1. The rectifier input isolator (Q1) is closed.</li> <li>2. The input voltage is within the limits of normal operation.</li> <li>3. The phase sequence of the mains input is correct.</li> <li>4. Verify that condition leading to an emergency stop has not happened, in which case a Reset must be carried out.</li> </ol> <p>If these checks do not give a positive result, request qualified assistance.</p>
3.	OFF	<p>If this yellow led is ON it signifies that the battery is not available. This could be due to the battery circuit breaker being open or that the d.c. busbar voltage is below the figures stated in the item(2) specified above.</p> <p>The battery circuit breaker will open automatically if the d.c. voltage falls below these levels.</p> <p>Check the following –</p> <ol style="list-style-type: none"> <li>1. Check that the conditions for led(2) are satisfied.</li> <li>2. DC busbar voltage – if not above 320V, then carry out checks as for led(2) – mains rectifier failure above. If d.c. busbar voltage is above 320V but you are unable to close the battery circuit breaker then seek qualified assistance.</li> <li>3. Battery circuit breaker is closed.</li> </ol> <p>If the above checks prove unsatisfactory, then seek qualified assistance.</p>
4.	ON	<p>If this green led is OFF, it signifies that the inverter is not producing its correct output voltage.</p> <p>Check the following –</p>

		<ol style="list-style-type: none"> <li>1. If [OVERTEMPERATURE] or [OVERLOAD] alarm messages are active then (after allowing the UPS to cool / checking that the load current on the Bypass line is not excessive) use the procedure to carry out the reset (see Chapter 5 – Operating Instructions).</li> <li>2. Check that the conditions for led(2) are satisfied.</li> <li>3. Check that the Inverter led(8) - yellow – is OFF, otherwise follow Inverter switch ON procedure.</li> <li>4. Check that no conditions exist which will prevent switching the INV ON (e.g. PC command).</li> <li>5. Verify that condition leading to an emergency stop has not happened, in which case a Reset must be carried out.</li> </ol>
5.	ON	If this green led is OFF, then it signifies that the load has been transferred to the Static bypass supply. If this is an automatic change over it will be accompanied by a fault warning on the display panel. Take the appropriate actions for the display indication (see Display alarm message table 7-2).
6.	OFF	This led is mutually exclusive to led(5). If this amber led is ON, the load has been transferred to the Bypass mains supply. Verify the cause by following the alarm indications at the LCD display panel. If the above checks prove unsatisfactory then seek qualified assistance.
13.	OFF	This red led will flash ON and OFF and indicates that the UPS has detected fault, it will be accompanied by a message on the display panel, take the required actions for the display panel message (see Display alarm message table 7-2). This will be accompanied by an audible warning. Pressing the Alarm silence switch (14) stops the audible alarm, but leaves the warning message displayed until the appropriate condition is rectified.
16.	OFF	If this yellow led is ON it signifies that the battery voltage is low and that the end of battery discharge is near. This will be accompanied by audible warning.
17.	N/A	This is a bargraph indicating the battery charge state and would normally have four or five of the leds ON. When the unit runs on battery, this bargraph changes to give an indication of the time remaining on the battery.
18.	N/A	This is a bargraph indicating the % of the total load that is being applied to the system.
19.	OFF	If this yellow led is ON it signifies that the applied load has exceeded the maximum. It will be accompanied by all five load bargraph leds being ON (item 18), the Alarm warning indication flashing RED (item 13) and an OVERLOAD messages on the visual display. This will be accompanied by an audible warning. <b>Reduce the load immediately.</b>

## 7.2 Display Panel Messages

The message displayed on Hipulse can be categorized into types:-

(a) ALARM messages - these are messages which needed urgent attention and warn of a UPS shutdown or imminent shutdown the load would normally transfer to the bypass supply if it is available. All alarm messages are accompanied by an audible warning.

(b) WARNING messages - these are the messages generated to warn or confirm to the operator of action taken (i.e. if the rectifier a.c. input supply power switch was opened the Warning message would read RECTIF. SWITCH OPEN).

The following table lists the various messages displayed on the operator panel together with a description of their interpretation.

Sr. No.	Display Message Alarm	Interpretation
1.	EMERGENCY STOP	This alarm indicates that the UPS was shut down by means of the local or remote (if fitted) Emergency Power Off push button (EPO) which is normally due to operation action – investigate the cause for pressing the button. If this button was not pressed then check the continuity of the circuit to the Remote switch, Customer connections, Auxiliary terminal block X4; pin 5 and 6; normally closed.
2.	INV. OFF	The INV. OFF alarm is active whenever the inverter is not producing its correct output voltage, either because it has been switched OFF or due to an internal fault, it will normally be accompanied by one or more of the other inverter fault conditions.
3.	INV: OVERVOLTAGE INV: UNDERVOLTAGE OUTPUT: NO VOLTAGE OUTPUT: WAVEFORM ERR	Most of the inverter fault messages are self explanatory, however the WAVEFORM ERR informs the operator that the output voltage peak has flattened caused by an internal inverter problem and therefore the output will be out of limits.
4.	INV. OVERTEMPER.	Over temperature is sensed by a normally-closed thermostat (90°C operating) fitted to each inverter heat sink. If an over temperature condition arises, the audible alarm will accompany this message; the inverter stops and load transfers to Bypass after 3 minutes.
5.	OVERTEMP. SHUTDOWN	This message informs the operator that the inverter has been switched OFF and that the load has been transferred to Bypass due to an Inverter over temperature.
6.	OVERLOAD PRESENT	The inverter overload has an inverse load/ time characteristic – i.e. it will accept 125% overload for 10 minutes and 150% overload for 60 seconds. If this characteristic is exceeded the load transfers to the bypass supply, the inverter stops and the overload alarm annunciates. The [OVERLOAD PRESENT] alarm will announce as soon as the load exceeds 100% of the UPS rating, and the load will transfer to Bypass some time later, depending on the degree of

overload present.

---

7.	OVERLOAD SHUTDOWN	This message informs the operator that the load has been transferred to bypass due to an inverter overload.
8.	OUTPUT SWITCH OPEN	This is a status alarm. The output switch must be selected 'CLOSED' at all times except when operating on the Maintenance bypass supply.
9.	BYPASS SWITCH OPEN	This is a status alarm. The bypass input switch must be closed all the times.
10.	BATTERY C.B. OPEN	This is a status indication only. Note that if the UPS is operating with the Battery circuit breaker open, and the mains power fails, then the UPS output will also fail together with load power, since the inverter has no battery backup.
11.	BATTERY: FUSE FAIL	This problem should be rectified as soon as possible. If the mains power fails then the UPS output will also fail together with load power, since there is no battery backup.
12.	BATTERY: TEST FAILED	The system has carried out a test of the battery. If this alarm is not accompanied by a [BATTERY C.B. OPEN] or [BATTERY: FUSE FAIL] message then a full check of the Battery bank is required.
13.	DC BUS: UNDERVOLTAGE	When the inverter is operating on the battery this message is displayed on the condition when battery voltage has fallen below a preset value. If the input a.c. power cannot be restored, you should shut down your loads.

---

---

14.	BATTERY: E.O.D.	Battery discharge has continued beyond a preset value. The inverter will shut down, the system will attempt a transfer to bypass. If Bypass is not available, any load connected to the UPS will be without power.
15.	RECT. OFF	The RECT. OFF alarm is active whenever the battery charger (rectifier) is not producing its correct output voltage. This can be caused by an operator selection to OFF, an Input supply failure, an open rectifier a.c. input power switch or an internal fault which may be accompanied by one of the fault conditions.
16.	RECT. SWITCH OPEN RECT. CURRENT LIMIT BATTERY: FUSE FAIL DC BUS: FAST OVERVOL	Most of the rectifier fault messages are self explanatory however, the DC BUS: FAST OVERVOLTAGE message informs the operator the d.c. busbar voltage is too high.
17.	BYP. ABSENT BYP. OVERVOLTAGE BYP. UNDERVOLTAGE BYP. FREQUENCY ERROR	INPUT FAILURE: input a.c. supply failed or out of specified acceptable range. Do not switch OFF the inverter while this indication is active or the load will lose its power.
18.	BYP. SCR FAILURE	One or more of the static switch SCR's has developed a fault. The bypass would not support the load in the event of a UPS failure, immediate action is required. Seek qualified assistance.
19.	BYP. PHASE ROT. ERROR	This message informs the operator that the input power lines have been cross-connected and the phases sequence is incorrect.
20.	MANUAL BYPASS CLOSED	This is a status warning that the load is being powered through the maintenance bypass line and is unprotected from mains supply aberrations.
21.	INV. UNSYNCHRONIZED	This warns that the inverter is not synchronized with the bypass supply, which is normally due to a problem with the bypass supply being outside an acceptable frequency window. Do not switch OFF the inverter when this alarm is active or the load will experience a 200 millisecond power break.

---

---

22.	BATTERY ON LOAD	This is a status warning that the battery is discharging. It normally accompanies a [BYP: ABSENT] or [RECT: OFF] message.
23.	AUTONOMY XXXX min	The micro monitors the battery percentage capacity while on charge and the battery time remaining while on discharge. It calculates the time remaining as function of the discharge current against the programmed ampere-hour capacity of the battery. It will update the time remaining as the load is change.
24.	BATTERY UNDER TEST	This message informs the operator that the system is carrying out a periodic battery test.
25.	BOOST TIME EXPIRED	This message is only applicable to systems which include the boost charge option, boost time charge elapsed set value, battery should be controlled by service personnel.
26.	LOAD ON BYPASS	This is a status warning that the load is being powered through the static bypass line and is unprotected from mains supply aberrations. This action is either selected by the operator or a fault condition, check for other fault messages.
27.	RECT: OFF RECT: OFF VIA DISPLAY	This is a status message confirming that the rectifier has been selected off by the operator from either the front panel display or an external PC or by a switch on UPS microprocessor PCB.
28.	BYP: OFF BYP: OFF VIA DISPLAY	This is a status message confirming that the bypass has been inhibited by the operator from either an external PC or by a switch on UPS microprocessor PCB.
29.	INV: OFF INV: OFF VIA DISPLAY	This is a status message confirming that the inverter has been selected off by the operator from either the front panel display or an external PC or by a switch on UPS micro controller PCB.

---



---

30.	BYP: XFER COUNT BLOCK	This message informs the operator that the load has been transferred to the bypass more than eight times in one minute. After eight transfers the load will remain on bypass. This message could be initiated by a load causing the UPS to overload, it requires investigation.
-----	-----------------------	---

---

31.	BATTERY: GROUND FALUT	This message informs the operator that the battery is not longer isolated from ground and there is danger of electrocution.
-----	-----------------------	---

---

32.	BACKFEED FAULT	This message informs the operator that the failure of the bypass static devices has resulted in voltage being fed back to the bypass supply input.
-----	----------------	--

---

In addition to the above message there are a number of software alarms (i.e. BAD EEPROM, BACK-UP, BATTERY LOW etc.) that will require attention from a qualified service engineer.



# 1 + N System

## 8.1 General

The system can comprise of up to 6 UPS modules of the same power rating and connected in parallel without the need for a centralized mains static bypass. Instead the bypass static switches of each UPS share the load when the system transfers to the main bypass supply.

From a 'power' viewpoint, each module is internally identical to the single module configuration. A 1+N parallel system requires inverter and bypass supplies, inter-module control signals to manage current sharing, synchronizing and bypass switching between the module. In the figure 8-1, this is shown as the 'inter-module control bus', which is facilitated through the use of multi-way ribbon cables connected between the units of the system.

When three or more modules are to be connected in parallel it is recommended that inductance should be inserted in the static bypass line. This can be installed internal to the UPS as an option.

For each module it is necessary to program the display panel with the correct rating and to identify that the internal static switch is being used.

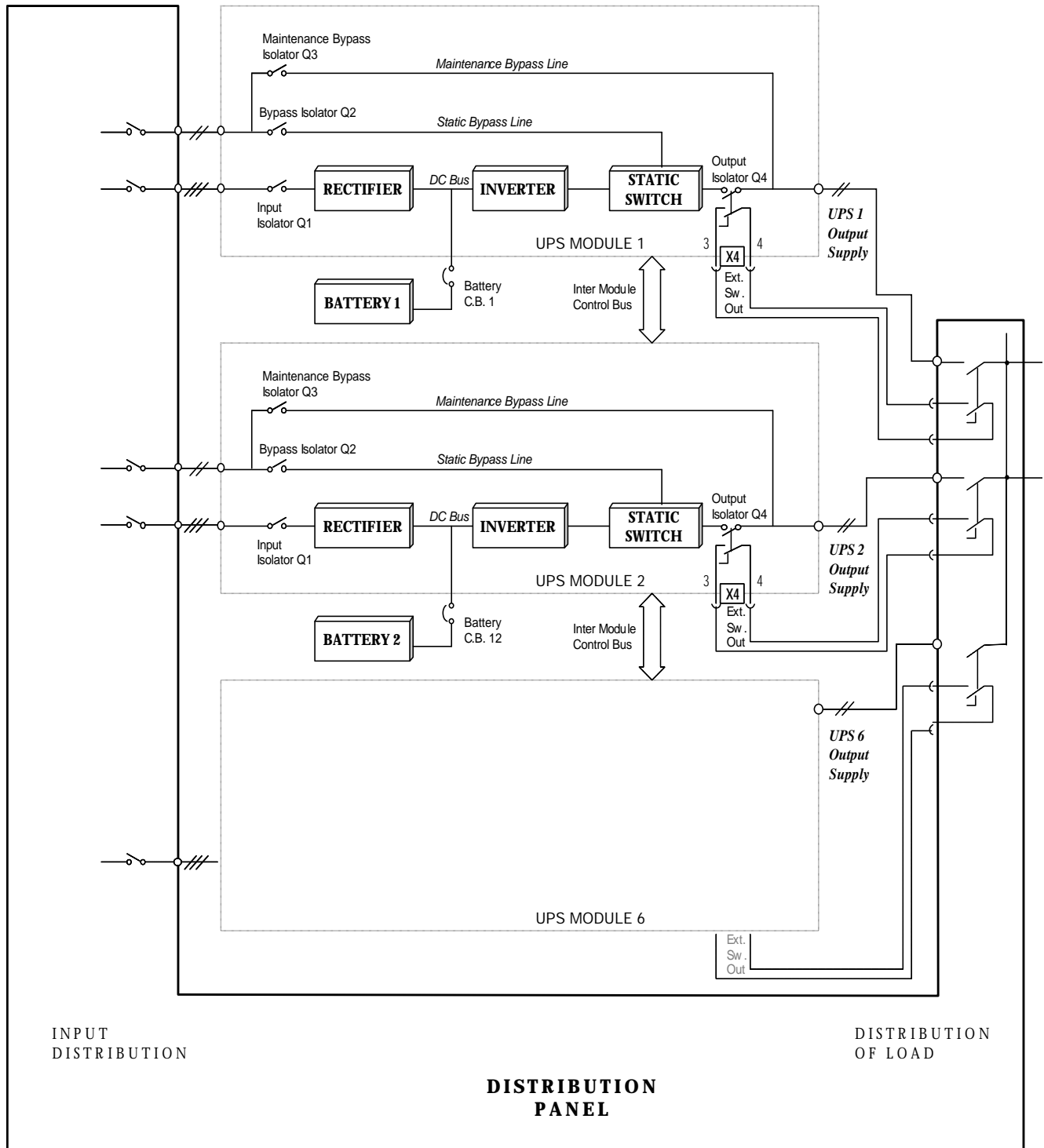

Fig 8-1: '1+N' System block diagram with Separate Batteries

## 8.2 Installation procedure

### 8.2.1 Preliminary Checks

Be sure that a parallel kit is present and fitted in each of the modules, and that the modules are of the same rating and with the same software and hardware release (see section 4.1.2 - Info window)

#### WARNING

Fitting of the parallel kits and board setting required to convert from Single Module to 1+N must be made by qualified and trained personnel. This operation involves also setting of system with separate batteries or common batteries.

### 8.2.2 Protective Devices

Refer to the instructions supplied in Chapter 3 - Electrical Installation - Section 3.1.6.

### 8.2.3 Power Cables

Input Bypass and Rectifier, outputs of module as described in Chapter 3.

### 8.2.4 Control Cables

#### **Inter-module control**

Modules are connected as shown in figure 8-3 using connected the other via Parallel Connector Board with shielded 34-way cables.

These cables are connected between the 'N' modules to pass control signals which govern module synchronization, load sharing, battery charge current sharing (in a common battery installation), load transfer operation and other general control and alarm functions. These signals are necessary to ensure correct system operation, and built-in redundancy allows the system to function if ever one of the 'N' cables becomes disconnected.

Cables entry is as identified in the mechanical drawings in Chapter 2.

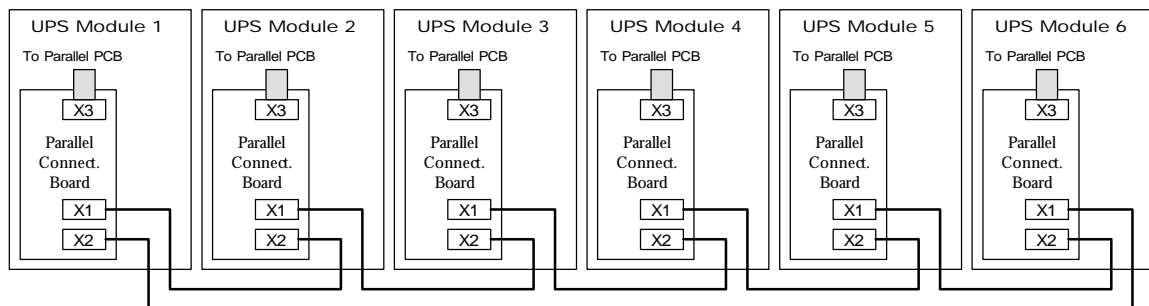

Fig 8-2: Connection of '1+N' system parallel single bus cables

### 8.2.5 Battery Control

The system is designed to operate with separate battery configuration. Installation procedure is same as for single module.

### 8.2.6 Emergency Stop

The external emergency stop facility is identical to that described for the single modules installation - that an individual Emergency Stop button is provided for each module.

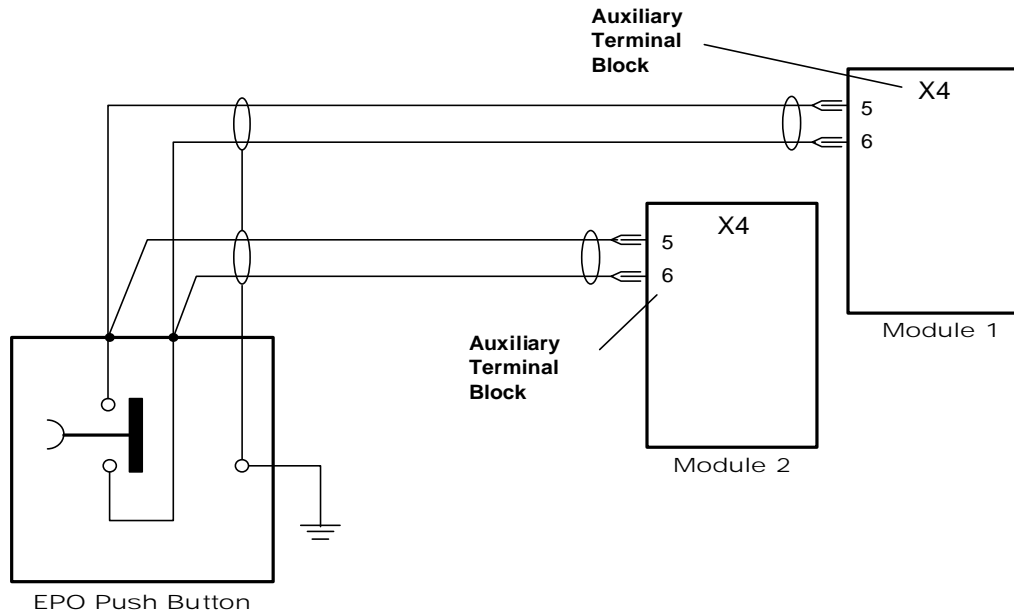

Fig 8-3: Connection of EPO Push Button

## 8.3 Operating Instruction

Starting and stopping the '1+N' system is the same as a single module, however the module's response depends on whether it is configured on the menu of the Operator Control Panel.

### 8.3.1 System Start-up and shutdown procedures (Separate Batteries)

#### WARNING

If differential circuit breakers are used on UPS unit inputs, use a common device only on the system's bypass mains. At the instant of electrical connection, the current may not be split instantaneously and this may cause the residual current circuit-breakers to trip separately.

These operations must be performed one at a time, progressing to the next step only after having completed the previous step on both UPS modules.

#### 8.3.1.1 System Start-up

This procedure should be followed when tuning on the UPS from a fully powered down condition - i.e. where the load is not being initially supplied at all. It is assumed that the installation is complete, the system has been commissioned by authorized personnel and the external power isolators are closed.

1. Open the UPS door(s) to gain access to the main power switches.

#### WARNING

The following action will apply power to the load equipment, ensure it is safe to do.

2. Close the Bypass power switch Q2  
The Module Mimic LED's will indicate Bypass supply healthy (1-steady green) and the Load on bypass (6 - flashing amber).  
The display screen will show the following:

```
EMERSON NETWORK POWER
3PH-1PH
UPS
```

```
RECTIF. SWITCH OPEN
BATTERY C.B. OPEN
MANUAL BYPASS CLOSED
hh.mm.ss dd.mm.yy
```

#### **Initializing Window:**

After first connecting power to the UPS and closing the Q2 isolator, this message will appear on the LCD screen. It persists for about five seconds while the control firmware is loaded. It is followed by a screen showing various messages with the time and date on the bottom line.

*Note: If input power is present but the display remains blank, then the Micro controller is not working, please contact your dealer for advice.*

```
BATTERY C.B. OPEN  
  
hh.mm.ss    dd.mm.yy
```

```
>MEASUREMENT    <  
FUNCTION  
MAINTENANCE  
SETUP
```

```
OUTPUT  
INPUT  
>BATTERY        <  
TEMPERATURE
```

```
BATTERY  
VOLTAGE        446 [V]  
CURRENT        001 [A]  
CHARGE         000 [%]
```

```
NORMAL OPERATION  
  
hh.mm.ss    dd.mm.yy
```

3. Close the Rectifier input power switch Q1 and UPS output power switch Q4.

After approximately 20 seconds the Module Mimic led's will change so that the Load on inverter will light (5-steady green) and the Load on bypass (6) will extinguish. The display window will show:

4. Before closing the battery circuit breaker check the d.c. bus-bar voltage. From the above window press the ENTER key. The Main menu will display:

Select MEASUREMENT and press ENTER key

Select BATTERY and the d.c. busbar voltage will be displayed.

If the voltage indicated is satisfactory (432V d.c. for 380V a.c. system, 446V d.c. for 400V a.c. system, and 459V d.c. for a 415V a.c. system ) press the escape key repeatedly until the display returns to the original window.

5. Manually close the battery circuit breaker.

The Module Mimic indicator (3) Battery unavailable should extinguish. Several led's on the Battery state of charge bargraph (17) will illuminate showing battery state of charge.

When the battery circuit breaker has been closed and the inverter has stabilized the screen will change to the default window.

**Default window:**

The message shown below, will be seen on the default screen whenever the UPS is operating normally.

The top lines display the UPS operational status and indicates alarm conditions when they occur; and the bottom line shows the time and day.

```
The UPS is operating normally with its inverter  
supplying the load.
```

Follow the foregoing procedure for the other UPS.

For a system configured in the "1+N system", the 'N' UPS modules will simultaneously change from "load on bypass" to "load on inverter" provided that a sufficient number of modules are running, and on-line, to satisfy the power load requirements.



### 8.3.1.2 Switching the system to maintenance bypass from normal operation

#### WARNING

The internal maintenance bypass must not be used when the UPS system is comprised of more than two UPS modules in parallel.

Follow the procedure for the single UPS by referring to Chapter 5 – Operating Instructions: Paragraph 5.4. For a system configured in the “1+N system”, the changeover from “load on inverter ” to “load on bypass” will occur only when the operation described in point 3 has been completed on both UPS modules.

### 8.3.1.3 Switching the system ON from a maintenance power down condition.

Follow the procedure for single UPS, referring to Chapter 5 – Operating Instructions: Paragraph 5.2 .

### 8.3.1.4 Switching OFF and isolating one UPS while the other remains in service.

1. In sequence, open the UPS isolators Q4 (output), Q1 (rectifier input), Q2 (bypass input).
2. Open the circuit-breaker inside the battery cabinet.

To completely isolate the UPS, open the a.c. power supply circuit-breaker (both circuit breakers if separate supplies are provided for the rectifier and the bypass supply) and the output circuit breaker on the power distribution switchboard.

If individual UPS output isolation circuit-breaker (and its auxiliary contacts) are not installed on the power distribution switchboard, remember that voltage supplied by the others UPS which remains in service still will be present on the output terminals of the shutdown UPS.

#### WARNING

If individual UPS output isolation circuit-breaker are not installed on the power distribution switchboard, remember that voltage supplied by the others UPS remains in service will still be present on the output terminals of the shutdown UPS.

**Warning : Wait 5 minutes for the internal d.c. busbar capacitors to discharge.**

### 8.3.1.5 Switching ON a UPS that was previously switched OFF and isolated from the system.

1. Close the circuit-breakers relative to the shutdown UPS that were previously opened on the power distribution switchboard.
2. Close the switches Q1 (rectifier input) and Q2 (bypass input) of the UPS.
3. Select the MEASUREMENT function from the display on the main menu, then press ENTER and select BATTERY. Press ENTER and check that the voltage level has reached the rated value (432V or 446 or 459 in accordance with no. of battery blocks).
4. Close the battery circuit-breaker.
5. Close the UPS switch Q4 (output), wait about 20 seconds and check the message NORMAL OPERATION appearing on the display operator panel.

### 8.3.1.6 Complete system shutdown

Follow the procedure described in Chapter 5 - Operating Instruction : paragraph 5.6 by working on several UPS modules.

### 8.3.1.7 Complete system reset

Follow the procedure described in Chapter 5 - Operating Instruction : paragraph 5.7 by working on several UPS modules.

## 8.4 Display Panel message interpretation in '1+N' System

The alarms are the same as for the single module, as given in the previous paragraph, with the additional alarms:

CODE	DISPLAY ALARM MESSAGE	INTERPRETATION
44	INV: PARALLEL ERROR	The parallel board has detected a wrong sharing of the load and has blocked its inverter. Seek qualified assistance.
46	NR: INVERTERS NOT OK.	The number of active inverters is below the preset capacity value.

# Specification

This specification describe requirements for an Uninterruptible Power System (UPS).

## 9.1 Conformity and Standard

The UPS has been designed to conform the following standards: IEC, EN

## 9.2 UPS Environmental

The UPS shall be able to operate under the following environmental conditions without damage or degradation in electrical operating characteristics:

Environmental Characteristics	Units	
Rated Power	kVA	130
Operating Temperature	°C	0 to 45 °C
Relative Humidity	%	= 90% at 31 °C, Saliferrous, Humid
Altitude of operation	m	= 1000m above sea level
Storage/ transport temperature	°C	-25 to 70 °C

## 9.3 UPS Mechanical Characteristics

Mechanical Characteristics	Units	130 kVA 6 pulse
Height	mm	1900
Width	mm	1400
Depth	mm	925
Ventilation	-	By internal intake fans
Cable entry	-	Bottom
Protection	IP	41

## 9.4 UPS Electrical Characteristics

<b>RECTIFIER INPUT MAINS</b>		
<b>I/P Ratings</b>	<b>Units</b>	<b>130 kVA 6 pulse</b>
Rated power	kVA	130
Rated Mains Voltage ①	Vac	380 – 400 – 415 V
Supply		Three phase without neutral
Input voltage tolerance ②	%	±10
Frequency	Hz	50 or 60
Input frequency tol.	%	± 5
Rated input power ③	kVA	143
Rated input current ③	A	206.4
Maximum input power ④	kVA	178
Maximum input current ④	A	257
Duration of progressive power walk-in ⑤	sec	2 to 10

① = 380V or 415V set changing taps on auxiliary supply transformer

② = With mains at –15% and suggested battery elements the UPS maintains the output rated voltage at rated load but cannot guarantee float charge to battery; the battery does not discharge.

③ = EN 50091-3 (1.4.39): UPS, rated load, input rated voltage 400V, no current to battery

④ = EN 50091-3 (1.4.40): UPS, rated load or overload, input rated voltage 400V, battery on boost charge with maximum allowed current.

⑤ = Set with jumper on Rectifier control board.

## 9.5 UPS Electrical Characteristics (DC Intermediate Circuit)

D. C. INTERMEDIATE CIRCUIT		
<b>Rated Power</b>	<b>kVA</b>	<b>130</b>
Voltage range for Inverter operation	Vdc	340 – 480
Recommended number of - Lead-acid cells ①-②	Nos.	190 (380 Vac) <b>198 (400 Vac)</b> 204 (415 Vac)
- Ni-Cd cells ①-②		320 (454.4 Vac)
Recommended float charge voltage 2.25 V/cell (Lead Acid) ①	Vdc	432 (380 Vac) <b>446 (400 Vac)</b> 459 (415 Vac)
1.42 V/cell (Ni-Cd) ①		454.4 Vac
Recommended boost charge voltage 2.40 V/cell (Lead Acid) ①	Vdc	460 (380 Vac) <b>475 (400 Vac)</b> 490 (415 Vac)
1.55 V/cell (Ni-Cd) ①		480 Vac
Recommended end of discharge voltage 1.67 V/cell (Lead Acid) ①	Vdc	320 (380 Vac) <b>330 (400 Vac)</b> 340 (415 Vac)
1.1 V/cell (Ni-Cd) ①		340 Vac
Recommended test voltage for Lead Acid ①	Vdc	365 (380 Vac) <b>376 (400 Vac)</b> 388 (415 Vac)
for Ni-Cd ①		384 Vac
Battery boost charge cycle ③	-	Characteristics to DIN 41772I-U, boost to floating charge switching, with current measuring criterion plus control of charging time.
Maximum boost charge duration ③	min	0-999
Boost-float threshold current ③	A	0-99
Ripple voltage superimposed ④	%	≤2

**Note:**

- ① = (According to rated voltage)
- ② = Factory set for rated 400V, different cells number and voltage per cell may be set by software and / or trimmers on Rectifier control board.
- ③ = Set by software
- ④ = Battery disconnected, RMS percentage value referred to DC voltage.

## 9.6 UPS Electrical Characteristics (Inverter Output)

INVERTER OUTPUT		
<b>Rated Power</b>	<b>kVA</b>	<b>130</b>
Rated mains voltage ①	Vac	380 - 400 - 415 Three phase with neutral
Frequency ②	Hz	50 to 60
Rated Power at $\cos\phi = 0.8$	KVA	130
Rated Power at $\cos\phi = 1$	KW	104
Overload	%	150% FOR 60 sec 125% for 10 min 110% for 1 hr
Maximum non linear load allowed ③	-	100% Pn
Voltage stability, steady state test ④	%	$\pm 1.5$
Voltage stability, transient test ⑤	%	$\pm 5$
Maximum rate of change of frequency ⑥	Hz /sec	0.1

**Note:**

- ① = Factory set 400V – 380V or 415V voltages with software setting
- ② = Factory set at 50Hz ; 60Hz with software setting.
- ③ = EN50091-3 (1.4.58) crest factor 3.
- ④ = EN50091-3 (4.3.4).
- ⑤ = EN50091-3 (4.3.7) also for 0-100% load transient, restore time 20ms to  $\pm 1\%$ .
- ⑥ = Factory set at 0.1Hz/ sec; upto 2 Hz/sec with software setting.

## 9.7 UPS Electrical Characteristics (Bypass Input Mains)

BYPASS INPUT MAINS		
<b>Rated Power</b>	<b>kVA</b>	<b>130</b>
Rated mains voltage ①	Vac	380 - 400 - 415
Supply		Three phase with neutral
Rated Current: 110 Vac	A	1182
Bypass voltage tolerance ②	%	± 10
Delay time to recognize bypass voltage returned to window	sec	10
Inverter output voltage window	%	± 10
Frequency ③	Hz	50 or 60
Input frequency tolerance ④	%	± 2
Maximum frequency slew rate	Hz /sec	0.1
Current rating of neutral cable		1.5 x In
Protection, bypass line		To avoid series fuses, the bypass line should be protected using an external device should be sized to discriminate with the load protection.
Overload	%	150% for 60 sec 125% for 10 min 110% for 1 hr

**Note:**

① = Factory set 400V – 380V or 415V set changing taps on auxiliary supply transformer and with software setting

② = Other values 0-15% with software setting.

③ = Factory set at 50Hz ; 60Hz with software setting.

④ = Other values 1-9% with software setting.





# ANNEXURE



### 10.1 Remote Alarm Monitor

The Remote Alarm Monitor (RAM) Board can be used in conjunction with the AS400 Alarms Interface Board to display the UPS alarm and status information at a remote station to 100 meters from the UPS.

The RAM, which can be mounted either horizontally or vertically contains a mains-driven power supply for alarm LED annunciation and displays the following warnings:

Panel	Colour	Normal state	Interpretation
Inverter ON	Green	ON	Normal operating condition indicating that the load is being supplied by the inverter. This is not an 'alarm' indicator.
Utility failure	Red	OFF	When lit, it indicates that the input bypass is out of tolerance or missing.
Battery low	Red	OFF	When lit, it indicates that the battery voltage is below minimum or that the battery circuit breaker is open.
Bypass ON	Red	OFF	When lit, it indicates that the load is being fed from the bypass supply, possibly due to a UPS failure.
Maintenance	Red	OFF	When lit, it indicates that the UPS has been selected to operate on the maintenance bypass and load is unprotected.
Alarm	Red	OFF	This is a 'common alarm' and is lit when any of the red leds described above are lit

Table A

An audible warning accompanies any of the above alarm conditions. This is, however, subject to a short time delay when activated in conjunction with the 'Utility Failure' and 'Bypass ON' alarms, to prevent the warning being activated by transient conditions. Pressing the 'reset' push-button cancels the audible warning but the alarm indications remain until the conditions is rectified.

#### 10.1.1 RAM Connections

##### Power Supply

The RAM contains a single-phase 220-240 V AC mains-driven power supply. Power is applied through a standard three-pin mains connector located in the RAM back panel (plug provided) -use 3-core 0.5 mm cable (minimum). The supply is rated at approximately 4 Watts and fused at 1 A.

It is advised that the power supply is taken from the UPS output, otherwise in the event of a mains failure the RAM may be inoperative.

##### Alarm connections

A 9 pin D-type connector with solder points is provided with the RAM. This connector fits into the 9 pin socket on the back of the RAM and should be cabled to the Interface Board # 10020112003 fitted to the UPS, using 9 core, 0.22 mm. (minimum) shielded cable as shown. The maximum recommended distance is 100 meters.

**Note:** Operation of the RAM indicators, is achieved by feeding a voltage across the module Alarm Board relay contacts. No other connections should be made across the relay contacts used.

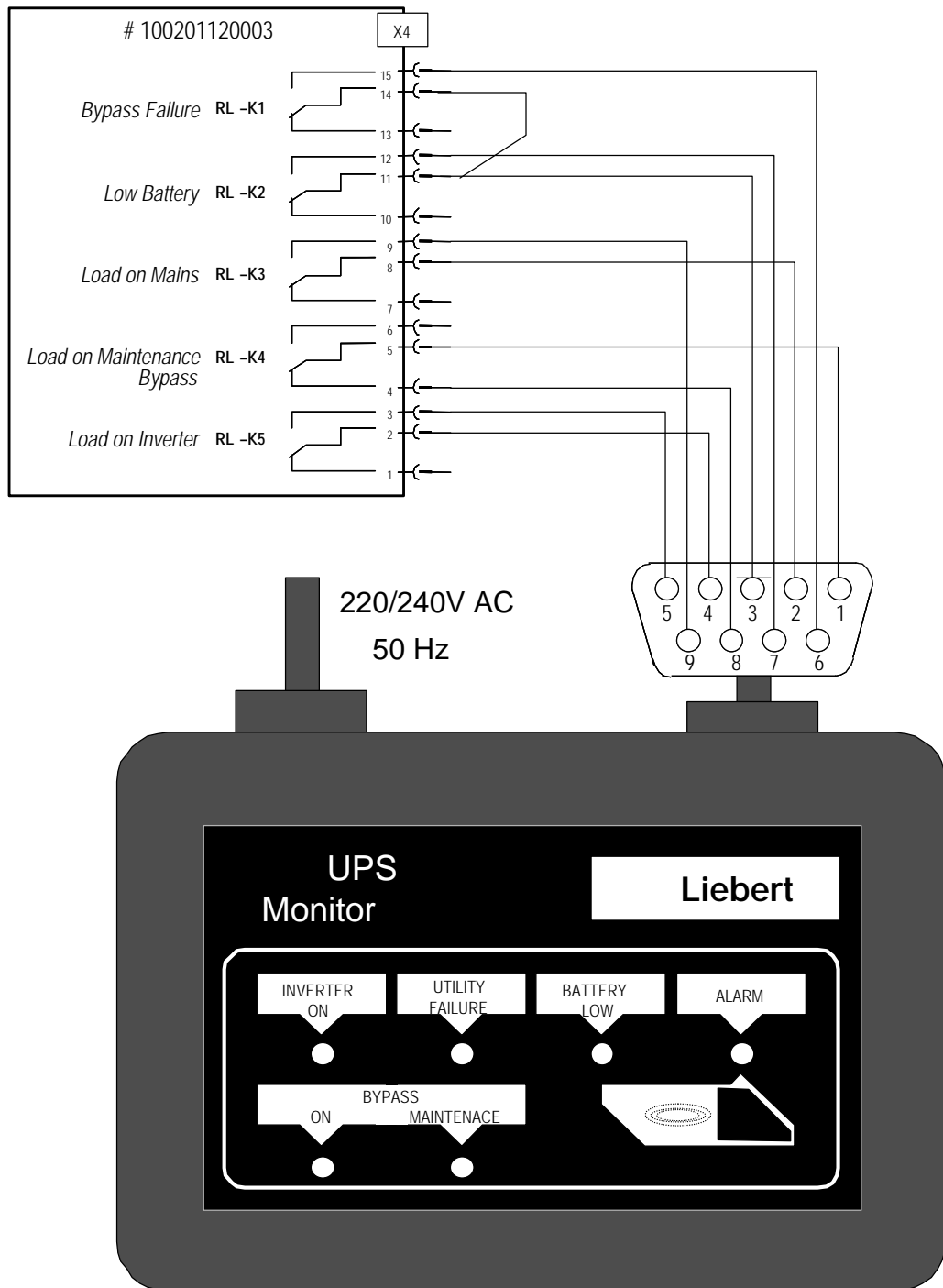

Figure 10.1: Remote Alarm Monitor connection details

## 10.2 INPUT TRANSFORMER CUBICLE

### 10.2.1 Introduction

The Input Transformer Cubicle is placed in the Input supply path of the UPS. It consists of Star - Star OR Delta - Star transformer of rated capacity to provide Isolation from the Input Distribution supply to the UPS input. The Cubicle also consists of Battery Breaker with its Battery Trip PCB of the respective UPS.

### 10.2.2 Termination

The Incoming Supply from the Customers distribution is fed as input to the Input Transformer Cubicle. The incoming supply 3ph,4wire is fed to RI,SI,TI,NI terminals.

The Battery Breaker input from the UPS is fed to +R1, -R1. The output of the Transformer cubicle is available on the RU,SU,TU,NU terminals, the Battery Breaker output is fed to BATTERIES through terminals +B, -B terminals.

### 10.2.3 Indication & Metering

LED's are used to monitor availability of Input voltage before the Isolation Transformer and after the Transformer which are seen on the Mimic Panel.

Incoming L-L voltage and Phase current is measured using Voltmeter & Current meter which are seen on the Mimic Panel, A selector switch S1 is used to select RY, YB, BR Voltage and R,Y,B Phase currents.

### 10.2.4 Protection

Incoming 3 pole MCCB is used as Protective Device before the Isolation transformer, Control fuses are used for protection of Voltmeter and Fans. Cubicle Battery path MCCB is used as Protective Device in Battery path.

Utility socket is provided for single phase supply.

## 10.3 BYPASS ISOLATION CUBICLE

### 10.3.1 Introduction

Bypass Isolation Cubicle is placed in the Bypass input path of the UPS. It consist of VEE Connected -Transformer of rated capacity to provide 3 phase to 1 phase transformation .

### 10.3.2 Termination

The Incoming Supply from the Customers distribution is fed as input to the Bypass Isolation Cubicle. The incoming supply 3ph,4wire is fed to RI ,SI,TI,NI terminals .

The output of the cubicle is available on the RU, NU terminals . which is fed 1 phase Bypass Supply to the UPS Panel.

### 10.3.3 Indication & Metering

LED's are used to monitor availability of Input voltage before the Vee Connected Transformer and after it ,which are seen on the Mimic Panel

Output voltage and Phase current is measured using Voltmeter & Current meter which are seen on the Mimic Panel .

### 10.3.4 Protection

Incoming 3 pole MCCB is used as Protective Device before the Vee Connected transformer ,Control fuses are used for protection of Voltmeter.

Utility socket is provide for single phase supply.

## Free Manuals Download Website

<http://myh66.com>

<http://usermanuals.us>

<http://www.somanuals.com>

<http://www.4manuals.cc>

<http://www.manual-lib.com>

<http://www.404manual.com>

<http://www.luxmanual.com>

<http://aubethermostatmanual.com>

Golf course search by state

<http://golfingnear.com>

Email search by domain

<http://emailbydomain.com>

Auto manuals search

<http://auto.somanuals.com>

TV manuals search

<http://tv.somanuals.com>