

# Liebert NX UPS

User Manual—10-30kVA, 400V, 50/60Hz





---

## TABLE OF CONTENTS

<b>1.0</b>	<b>SINGLE MODULE UPS INSTALLATION</b>	<b>3</b>
1.1	Introduction	3
1.2	Preliminary Checks	3
1.3	Location	4
1.3.1	UPS Room	4
1.3.2	External Battery Room	4
1.3.3	Storage	4
1.4	Positioning	5
1.4.1	System Cabinets	5
1.4.2	10 to 30kVA UPS	5
1.4.3	Moving the Cabinets	5
1.4.4	Clearances	6
1.4.5	Access	6
1.4.6	Final Positioning	6
1.4.7	Floor Anchoring	6
1.4.8	Cable Entry	6
1.5	External Protective Devices	6
1.5.1	Rectifier and Bypass Input	6
1.5.2	External Battery	7
1.5.3	UPS Output	7
1.6	Power Cables	8
1.6.1	Cable Termination	9
1.7	Control Cables and Communication	11
1.7.1	Monitor Board Features	11
1.8	Dry Contacts	12
1.8.1	Input Dry Contacts	12
1.8.2	Maintenance Bypass Cabinet Interface	12
1.8.3	External Circuit-Breaker Interface	13
1.8.4	Output Dry Contacts	14
1.8.5	Emergency Power Off Input	15
1.8.6	External Bypass Switch Interlock	16
1.8.7	Battery Start Facility	16
<b>2.0</b>	<b>BATTERY INSTALLATION</b>	<b>17</b>
2.1	Introduction	17
2.2	Safety	18
2.3	Battery Cabinet	19
2.3.1	Introduction	19
2.3.2	Temperature Considerations	19
2.3.3	Dimensions	19
2.3.4	Weight	19
2.3.5	Circuit Isolator Features	19
2.3.6	Battery Temperature Sensor (Optional)	20
2.3.7	Moving the Battery Cabinets	20
2.3.8	Cable Entry	20
2.3.9	General Arrangement Drawings	21

2.4	Battery Power Cables . . . . .	24
2.4.1	Connection Principles . . . . .	24
2.4.2	Fitting the Batteries . . . . .	25
2.4.3	Connecting the Battery . . . . .	25
2.4.4	Battery Room Design . . . . .	25
2.5	Battery Control . . . . .	25
<b>3.0</b>	<b>UPS MULTI-MODULE INSTALLATION . . . . .</b>	<b>26</b>
3.1	General . . . . .	26
3.2	Paralleled UPS Modules . . . . .	27
3.2.1	Cabinet Installation . . . . .	27
3.2.2	External Protective Devices . . . . .	28
3.2.3	Power Cables . . . . .	28
3.2.4	Control Cables . . . . .	29
3.3	Hot-Standby UPS Modules . . . . .	29
3.3.1	Cabinet Installation . . . . .	29
3.3.2	External Protective Devices . . . . .	29
3.3.3	Power Cables . . . . .	30
3.4	Dual Bus System . . . . .	31
3.4.1	Cabinet Installation . . . . .	31
3.4.2	External Protective Devices . . . . .	31
3.4.3	Power Cables . . . . .	31
3.4.4	Control Wires . . . . .	32
3.4.5	Extended Dual Bus Synchronization Option (DBS Interface Box) . . . . .	32
<b>4.0</b>	<b>INSTALLATION DRAWINGS . . . . .</b>	<b>33</b>
<b>5.0</b>	<b>OPERATION . . . . .</b>	<b>39</b>
5.1	Introduction . . . . .	39
5.1.1	Split-Bypass Input . . . . .	39
5.1.2	Static Transfer Switch . . . . .	40
5.1.3	Battery Temperature Compensation . . . . .	40
5.1.4	Redundant Control Power Supply Board . . . . .	41
5.1.5	Socket Outlet . . . . .	41
5.2	Multi Module UPS—1+N . . . . .	41
5.2.1	Features of NX Multi-Module UPS Configurations . . . . .	42
5.2.2	Requirements for Paralleling of UPS Modules . . . . .	42
5.3	Modes of Operation . . . . .	42
5.3.1	Normal Mode . . . . .	42
5.3.2	Battery Mode (Stored Energy Mode) . . . . .	42
5.3.3	Auto-Restart Mode . . . . .	42
5.3.4	Bypass Mode . . . . .	43
5.3.5	Maintenance Mode (Manual Bypass) . . . . .	43
5.3.6	ECO Mode (Single UPS Only) . . . . .	43
5.3.7	Parallel Redundancy Mode (System Expansion) . . . . .	43
5.3.8	Hot-Standby Mode . . . . .	43
5.3.9	Frequency Converter Mode . . . . .	43
5.4	Battery Management—Set During Commissioning . . . . .	44
5.4.1	Normal Function . . . . .	44
5.4.2	Advanced Functions (Software Settings Performed by the Commissioning Engineer) . . . . .	44

5.5	Battery Protection (settings by commissioning engineer) . . . . .	44
<b>6.0</b>	<b>OPERATING PROCEDURES . . . . .</b>	<b>45</b>
6.1	Introduction . . . . .	45
6.1.1	Power Switches . . . . .	45
6.2	UPS Startup . . . . .	46
6.2.1	Start-Up Procedure . . . . .	46
6.2.2	Verify Switching Between Operation Modes . . . . .	47
6.3	Switching the UPS from Normal to Maintenance Bypass . . . . .	48
6.4	Powering Down the UPS . . . . .	48
6.5	Powering Down the UPS and Maintaining Power to Load . . . . .	49
6.6	Emergency Shutdown With EPO . . . . .	50
6.7	Auto Restart . . . . .	50
6.8	Reset After Shutdown for Emergency Stop (EPO Action) or Other Conditions . . . . .	50
6.9	Language Selection . . . . .	51
6.10	Changing the Current Date and Time . . . . .	51
6.11	Command Password . . . . .	51
6.12	Isolating One Module in a Multi-Module System . . . . .	52
6.13	Inserting One Module into a Multi-Module System . . . . .	53
<b>7.0</b>	<b>OPERATOR CONTROL PANEL AND DISPLAY . . . . .</b>	<b>54</b>
7.1	Introduction . . . . .	54
7.1.1	Mimic Power Flow . . . . .	55
7.1.2	Audible Alarm (Buzzer) . . . . .	55
7.1.3	Direct Access Push Buttons (Keys) . . . . .	56
7.1.4	LCD Monitor and Menu keys . . . . .	56
7.1.5	Detailed Description of Menu Items . . . . .	58
7.2	All Status and Event Messages Displayed on the UPS Front Panel . . . . .	60
7.3	Prompt (Pop-Up) Windows . . . . .	64
7.4	Dynamic Energy Flow Chart and UPS Help Screen . . . . .	64
7.5	Default Screen Saver . . . . .	65
<b>8.0</b>	<b>OPTIONS—FOR ASSEMBLY INSIDE THE UPS CABINET . . . . .</b>	<b>66</b>
8.1	Protection . . . . .	66
8.1.1	Battery Ground Fault Detection . . . . .	66
8.1.2	Redundant Fan for Power Module . . . . .	67
8.1.3	OC Web Card - SNMP/HTTP Network Interface Card . . . . .	68
8.1.4	Relay Card . . . . .	69
8.1.5	Multiport-4 Card . . . . .	69
8.2	OC485 Web Card – Modbus, Jbus, IGM Net . . . . .	71
8.2.1	Remote Alarm Monitor . . . . .	71
8.2.2	Dust Filter for 10-30kVA . . . . .	72
<b>9.0</b>	<b>TECHNICAL SPECIFICATIONS . . . . .</b>	<b>73</b>
9.1	Conformity and Standards . . . . .	73

---

## FIGURES

Figure i	Model number nomenclature . . . . .	vi
Figure 1	Residual current circuit breakers (RCCB) symbols . . . . .	7
Figure 2	Auxiliary terminal block detail monitoring board (U2) . . . . .	11
Figure 3	Input dry contacts . . . . .	12
Figure 4	Jumper connection for BCB interface . . . . .	13
Figure 5	Output dry contacts and EPO wiring . . . . .	14
Figure 6	Battery start for UPS . . . . .	16
Figure 7	Single temperature sensor and monitor board-U2 . . . . .	20
Figure 8	Battery cabinet bottom cable entry location . . . . .	21
Figure 9	Battery cabinet with fuse or optional circuit breaker locations . . . . .	22
Figure 10	Battery cabinet internal layout . . . . .	23
Figure 11	Battery cabinet, bottom entry . . . . .	24
Figure 12	Battery room design . . . . .	25
Figure 13	Emergency power off connections . . . . .	26
Figure 14	Typical 1+N system block diagram with common input supply, with separate batteries and optional output / bypass distribution panel . . . . .	27
Figure 15	Dry contacts, multiple UPS modules with distribution panel . . . . .	28
Figure 16	Connection of 1+N system parallel control cables. . . . .	29
Figure 17	Hot standby configuration . . . . .	30
Figure 18	Typical dual bus system configuration with static transfer switch and Load Bus Synch . . . . .	31
Figure 19	Connections of a typical dual bus system utilising Load Bus Synch . . . . .	32
Figure 20	Electrical connections . . . . .	33
Figure 21	General arrangement—10-30kVA UPS module . . . . .	34
Figure 22	10-30kVA NX front view with doors open . . . . .	35
Figure 23	Location of parallel logic board M3 . . . . .	36
Figure 24	Internal battery layout and connecting—GP12120 F2 (12AH/12V) . . . . .	37
Figure 25	Internal battery layout and connecting—LC-R127R2PG1 (7.2AH/12V) . . . . .	37
Figure 26	Internal battery layout . . . . .	38
Figure 27	Single unit block diagram with split-bypass input . . . . .	39
Figure 28	Multiple battery temperature sensors . . . . .	40
Figure 29	1+N multi-module UPS with external maintenance bypass switch . . . . .	41
Figure 30	Example of configuration for single UPS with external maintenance bypass cabinet. . . . .	49
Figure 31	UPS control and display panel . . . . .	54
Figure 32	Graphic LCD monitor windows and keypad . . . . .	56
Figure 33	Menu tree . . . . .	57
Figure 34	Help screen . . . . .	64
Figure 35	Default screen . . . . .	65
Figure 36	Battery ground fault detection set connections. . . . .	66
Figure 37	Redundant power module fan set. . . . .	67
Figure 38	Communication bays and cable location . . . . .	67
Figure 39	OC Web Card data summary window . . . . .	68
Figure 40	OC Web Card battery data summary . . . . .	68
Figure 41	SiteNet MultiPort4 Intellislot pin configuration. . . . .	70
Figure 42	OC485 Web card . . . . .	71
Figure 43	Dust filter replacement. . . . .	72

---

## TABLES

Table 1	Maximum steady state AC and DC currents. . . . .	8
Table 2	Distance from floor to connection point on the equipment. . . . .	8
Table 3	Input dry contacts at X3. . . . .	12
Table 4	Maintenance bypass cabinet interface. . . . .	12
Table 5	External circuit-breaker interface . . . . .	13
Table 6	Output dry contact relays. . . . .	14
Table 7	EPO input contact relays . . . . .	15
Table 8	Dimensions and weight. . . . .	19
Table 9	UPS operating modes . . . . .	45
Table 10	Rotary switch configurations. . . . .	45
Table 11	UPS control and display panel components . . . . .	54
Table 12	Rectifier indicator—1 . . . . .	55
Table 13	Battery indicator—2 . . . . .	55
Table 14	Bypass indicator—3 . . . . .	55
Table 15	Inverter indicator—4 . . . . .	55
Table 16	Load indicator—5 . . . . .	55
Table 17	Status (Alarm) indicator—6 . . . . .	55
Table 18	Audible alarm key. . . . .	55
Table 19	Menu key Icons and their meaning . . . . .	56
Table 20	UPS system window . . . . .	58
Table 21	Descriptions of UPS menus and data window items . . . . .	58
Table 22	UPS messages . . . . .	60
Table 23	Prompt windows, meanings . . . . .	64
Table 24	Dry contact fault alarm signal is available for remote monitoring . . . . .	66
Table 25	Relay Card pin configuration . . . . .	69
Table 26	Relay card jumpers . . . . .	69
Table 27	SiteNet MultiPort4 Intellislot pin assignment . . . . .	70
Table 28	NX communication options. . . . .	71
Table 29	Compliance with European, international standards. . . . .	73
Table 30	Environmental characteristics . . . . .	73
Table 31	Overall efficiency, heat losses and air exchange . . . . .	73
Table 32	Mechanical characteristics . . . . .	74
Table 33	Rectifier AC input (mains) . . . . .	74
Table 34	Battery. . . . .	75
Table 35	Inverter output to critical load. . . . .	75
Table 36	Bypass mains input. . . . .	76

Figure i Model number nomenclature

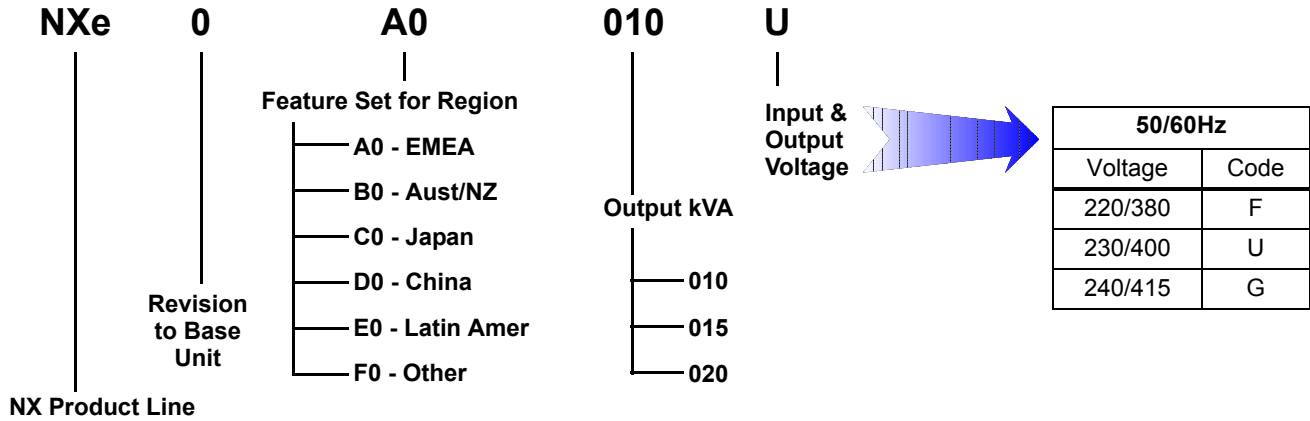

UPS Single Module
Liebert NXe UPS module ratings: 10, 15, 20, 30kVA (with internal battery)
<b>Example:</b> NXE0A0010U = 10kVA module for Europe and Middle East, 400V/230V output

Options	Model Identification	Note
Battery cabinet	NXE0NBCS	
Battery Ground Fault detection kit	NXA0UFXBGF	
Battery temperature probe (for external battery)	NXA0UFXBTS	
Maintenance bypass cabinet (separate bypass input)	NXE0NMBX	Specify total system kVA
Fan Redundancy kit	NXE0UFXRF	Specify UPS kVA rating
Seismic Anchor kit	NXA0UFXSAN	
Dual bus control cable 05-10-15 metres	NXA0UFXD	Specify length in metres
Parallel control cable kit 05-10-15 metres	NXA0UFXP	
Relay Card (On Bat, Bat Low, On Byp, Sum, UPS Fail) MultiPort4 (4 sets On Bat, bat Low) Web browser/TCP/IP/SNMP Card Jbus/Modbus Card	RELAYCARD-INT MULTIPOINT 4 OCWEB-LB OC485CARD	These are Intellislot plug-in cards (3 slots available).
RAM - Remote Alarm Monitor	NXA0CFXRAM	Requires RELAYCARD-INT
Modem card	NXA0CFXMOD	
Extended LBS box	NXA0UFXLBS	
Air Filter	NXA0UFXARF	One filter
Dual Bus Extension Kit 50-150 Meters	NXXXXMLBSKIT	(XXX: 050 or 150) - Specify length in meters. Used for extension in length or dual bus arrangement between Nx and non-Nx sources'
Individual Battery Monitoring	BDS 40 or BDS 256	Specify number of blocks. Consult Emerson Network Power representatives for complete configuration



---

## SAFETY PRECAUTIONS

This manual contains information concerning the installation and operation of this Emerson Network Power Liebert NX™ Uninterruptible Power System (UPS).

This manual should be read before commencing installation.

The UPS must be commissioned and serviced by an engineer approved by the manufacturer (or agent).

Failure to do so could result in personnel safety risk, equipment malfunction and invalidation of warranty.

The Liebert NX has been designed for Commercial/Industrial use only, and is not recommended for use in life support applications.

This is a low emission CLASS A Uninterruptible Power System (UPS) product. In a residential environment, this product may nevertheless cause radio interference, in which case, the user may be required to take additional measures.

### Conformity and Standards

This equipment complies with CE directives 73/23 & 93/68 (LV Safety) and 89/336 (EMC), with Australia and New Zealand EMC Framework (C-Tick) and with the following product standards for Uninterruptible Power System (UPS).

- EN / IEC / AS 62040-1-1—General and safety requirements for use in operator access area
- EN / IEC / AS 62040-2—EMC requirements; Class A compliant
- EN / IEC / AS 62040-3—Performance requirements and test methods

For more details, see **9.0 - Technical Specifications**

Continued compliance requires installation in accordance with these instructions and the use of manufacturer approved accessories only.



### WARNING

High Leakage Current

EARTH CONNECTION IS ESSENTIAL BEFORE CONNECTING THE INPUT SUPPLY.

Earth leakage current exceeds 3.5 mA and is less than 860 mA.

Transient and steady-state earth leakage currents, which may occur when starting the equipment, should be taken into account when selecting instantaneous RCCB or RCD devices.

Residual Current Circuit Breakers (RCCBs) must be selected sensitive to DC unidirectional pulses (class A) and insensitive to transient current pulses.

Note also that the earth leakage currents of the load will be carried by this RCCB or RCD.

This equipment must be earthed in accordance with the local electrical code of practice.



### WARNING

Back-Feed Protection Notice

This UPS is fitted with a voltage-free contact closure signal for use with an external automatic disconnect device (supplied by others) to protect against back-feeding voltage into the bypass input. If this signal is not used by the installer, a label must be added at the external bypass input disconnect device to warn service personnel that the circuit is connected to a UPS.

The text to use is the following or equivalent:

***ISOLATE THE UNINTERRUPTIBLE POWER SYSTEM BEFORE WORKING ON THIS CIRCUIT.***

---

## User-Serviceable Parts

All equipment maintenance and servicing procedures involving internal access requires the use of a tool and should be carried out only by trained personnel. There are no user-serviceable parts behind covers requiring a tool for removal.

This UPS is fully compliant with safety regulations for equipment located in an operator accessible area. Hazardous voltage is present within the UPS and battery enclosure but out of reach of non-service personnel. Contact with hazardous voltage is minimized by housing live parts behind safety panels that require a tool for their removal. No risk exists to any personnel when operating the equipment in the normal manner, following the recommended operating procedures.

## Battery Voltage Exceeds 400VDC

All physical battery maintenance and servicing requires the use of a tool or a key and should be carried out only by trained personnel.



## WARNING

Special care should be taken when working with the batteries associated with this equipment. When connected together, the battery terminal voltage will exceed 400VDC and is potentially lethal.

Battery manufacturers supply details of the necessary precautions to be observed when working on, or in the vicinity of, a large bank of battery cells. These precautions should be followed implicitly at all times.

Attention should be paid to the recommendations concerning local environmental conditions and the provision of protective clothing, first aid and fire-fighting facilities.

## 1.0 SINGLE MODULE UPS INSTALLATION

---

### 1.1 Introduction

This following section describes the requirements that must be taken into account when planning the positioning and cabling of the Liebert NX uninterruptible power supply and related equipment.

This chapter is a guide as to general procedures and practices that should be observed by the installing engineer. The particular conditions of each site will determine the applicability of such procedures.



### WARNING

#### Professional Installation Required

Do not apply electrical power to the UPS equipment before being authorised to do so by the commissioning engineer.

The UPS equipment shall be installed by a qualified electrical tradesperson in accordance with the information contained in this manual. All equipment not referred to this manual is shipped with details of its own mechanical and electrical installation.



#### NOTE

*Three-phase, 4-wire input supply required.*

*The standard Liebert NX UPS is suitable for connection to 3-phase, 4-wire (+ Earth) TN, TT and IT AC power distribution systems (IEC60364-3). Optional 3-wire to 4-wire conversion transformers are available. If it is used in IT AC power distribution systems, a 4-pole circuit breaker must be used on the input and refer to the relative IT Systems' standard*



### WARNING

#### Battery Hazards

Special care should be taken when working with the batteries associated with this equipment. When connected together, the battery terminal voltage will exceed 400VDC and is hazardous.

Eye protection should be worn to prevent injury from accidental electrical arcs.

Remove rings, watches and all other metal objects.

Use only tools with insulated handles.

Wear rubber gloves.

If a battery leaks electrolyte or is otherwise physically damaged, it must be replaced, stored in a container resistant to sulfuric acid and disposed of in accordance with local regulations.

If electrolyte comes into contact with the skin, the affected area should be washed immediately with water.

### 1.2 Preliminary Checks

Before installing the UPS, please carry out the following preliminary checks:

1. Visually examine the UPS and battery equipment for transit damage, both internally and externally. Report any damage to the shipper immediately.
2. Verify that the correct equipment is being installed. The equipment supplied has an identification tag on the back of the main door reporting: the type, size and main calibration parameters of the UPS.

## 1.3 Location

### 1.3.1 UPS Room

The UPS and its internal battery is intended for indoor installation and should be located in an environment with clean air and with adequate ventilation to keep the ambient temperature within the specified operating range (see **Table 30**).

All models in the Liebert NX UPS range are air-cooled with the aid of internal fans. Cold air enters through ventilation grilles at the front of the cabinet and hot air is released through the grilles at the back. Do not cover the ventilation openings.

If necessary to avoid room temperature build-up, install a system of room extractor fans. Optional air filters are available if the UPS is to operate in a dusty environment.

The UPS heat dissipation detailed in **Table 31** can be used as a guide for air conditioning sizing, depending on the selected mode of operation:

- Normal Mode (VFI SS 111 Double Conversion UPS)
- ECO Mode (VFD SS 311 Stand By UPS)

If in doubt use Normal Mode figures.



#### NOTE

*The UPS is suitable for mounting on concrete or other non-combustible surface only.*

### 1.3.2 External Battery Room

Batteries should be mounted in an environment where the temperature is consistent and even over the whole battery. Temperature is a major factor in determining the battery life and capacity. Typical battery manufacturer performance data are quoted for an operating temperature between 20 and 25°C (68 and 77°F). Operating above this range will reduce the battery life while operation below this range will reduce the battery capacity. In a normal installation the battery temperature is maintained between 15°C and 25°C (59 and 77°F). Keep batteries away from main heat sources or main air inlets etc.

Where the batteries are located externally to the main UPS cabinet, a battery protection device (e.g., fuses or circuit breakers) must be mounted as close as possible to the batteries themselves, and connected using the most direct route possible.

### 1.3.3 Storage

Should the equipment not be installed immediately, it must be stored in a room for protection against excessive humidity and or heat sources (see **Table 30**).



#### CAUTION

An unused battery must be recharged periodically per battery manufacturer recommendation. Temporarily connecting the UPS to a suitable AC supply mains and activating it for the time required for recharging the batteries can achieve this.

## 1.4 Positioning

The cabinet is mounted on four castor-wheels for ease of positioning and for short distance movement. Jacking feet are provided to prevent the UPS from moving once it has been wheeled to its final position.

For optimal design life, the place chosen must offer:

- Easy connection
- Enough space to easily work on the UPS
- Sufficient air exchange of enough to dispel heat produced by UPS
- Protection against atmospheric agents
- Protection against excessive humidity and very high heat sources
- Protection against dust
- Compliance with the current fire prevention requirements
- Operating environment temperature between 20°C and 25°C (68 and 77°F). The batteries are at maximum efficiency in this temperature range (see **Table 30**).

The UPS cabinet is constructed around a steel chassis with removable panels. The top and side panels are secured to the chassis by screws.

Access to the power terminals, auxiliary terminals blocks and power switches is from the front. Operational status and alarm information is provided through the front door operator control panel. Models 30kVA and below house both the power components and an internal battery. Cooling air enters the front of the NX and is exhausted out the rear.

### 1.4.1 System Cabinets

A UPS may comprise a number of cabinets, depending on the design requirements (e.g., UPS cabinet, external battery cabinet, external bypass cabinet). In general, all the Liebert cabinets used in a particular installation are of the same height and designed to be positioned side-by-side to form a matching array.

Refer to **4.0 - Installation Drawings** for assistance on positioning the cabinets described below.

### 1.4.2 10 to 30kVA UPS

The UPS consist of a single cabinet, which uses typically forty (40) 12V battery blocks, fitted internally and connected in series to provide a nominal battery voltage. The UPS may be shipped without the batteries fitted.

An extended battery option is available. This comprises a separate cabinet containing additional batteries that can be connected to the UPS to increase its battery run time.

### 1.4.3 Moving the Cabinets



## WARNING

Ensure that any equipment used to move the UPS cabinet has sufficient lifting capacity.

The UPS is fitted with casters. Take care to prevent the NX from moving when unbolting the unit from its shipping pallet. Ensure that adequate personnel and lifting aids are available when removing the shipping pallet.

Ensure that the UPS weight is within the designated surface weight loading of any handling equipment. See **Table 32**.

UPS and optional cabinets (battery cabinets, top cable entry cabinets, etc.) can be handled by means of a forklift or similar equipment.

The UPS cabinet also can be moved short distances by its casters.



## NOTE

*Care must be taken when maneuvering units fitted with batteries. Keep such moves to a minimum.*

#### 1.4.4 Clearances

The Liebert NX has no ventilation grilles at either side of the UPS. To enable routine tightening of power terminations within the UPS, in addition to meeting any local regulations, Liebert recommends providing adequate clearance in the front of the equipment for unimpeded passage of personnel with the doors fully opened. It is important to leave of 150mm (5.9") clearance behind the UPS to permit adequate circulation of air coming out of the unit.

#### 1.4.5 Access

The component layout of the UPS supports front and top access while servicing, diagnosing and repairing the UPS, thus reducing the space requirement for side and rear access.

#### 1.4.6 Final Positioning

The UPS cabinets are fitted with casters on the base to allow ease of movement and positioning.



### WARNING

Casters are strong enough for movement across even surfaces only. Caster failure could occur if they are subjected to shock loading.

When the equipment has been finally positioned, ensure the adjustable feet are set so that the UPS will remain stationary and stable.

#### 1.4.7 Floor Anchoring

Diagrams in **4.0 - Installation Drawings** show the location of the holes in the base plate through which the equipment may be bolted to the floor. If the equipment is to be installed on a raised floor it should be mounted on a pedestal suitably designed to accept the equipment point loading. Refer to the base view **Figure 21** to design this pedestal.

#### 1.4.8 Cable Entry

Cables can enter the Liebert NX UPS and battery cabinet from below. Cable entry is made possible by removing a blanking piece fitted at the bottom of equipment to reveal the cable entry hole.

### 1.5 External Protective Devices

Circuit breakers or other protective devices must be installed in the AC supply, external to the UPS. This chapter provides guidelines for qualified installers who must have knowledge of local wiring practices pertaining to the equipment to be installed.

#### 1.5.1 Rectifier and Bypass Input

Overcurrent protection must be installed at the distribution panel of the incoming main supply. The protection must discriminate with the power cables current capacity and with the overload capacity of the system (see **Table 35**). As a guideline, a thermomagnetic circuit breaker, with an IEC 60947-2 trip curve C (normal) for 125% of the current listed in **Table 1** is suitable.

**Split-Bypass**—If a split-bypass is used, install separate protective devices for the rectifier and for the bypass in the incoming mains distribution panel.



#### NOTE

*Rectifier and bypass input sources must be referenced to the same neutral potential.*



#### NOTE

*For IT power systems, four-pole protective devices must be used, external to the UPS, both upstream of the input distribution panel and downstream (toward the load).*

### Earth Leakage (RCD):

Any residual current detector (RCD) installed upstream of the UPS input supply must be:

- sensitive to DC unidirectional pulses (Class A)
- insensitive to transient current pulses, and
- must have an average sensitivity, adjustable between 0.3 and 1A.

**Figure 1 Residual current circuit breakers (RCCB) symbols**

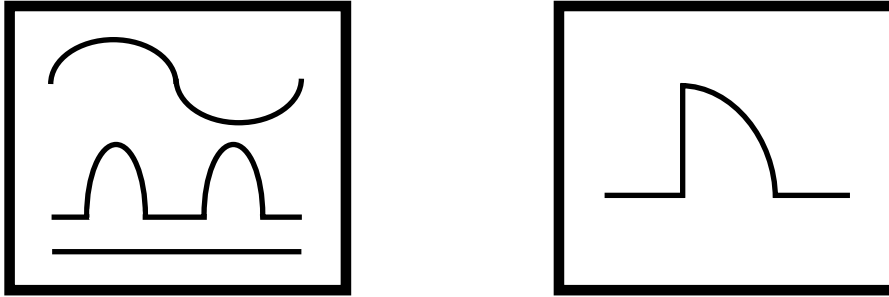

To avoid false alarms, earth leakage monitoring devices when used in systems with split-bypass input or when used in paralleled UPS configurations, must be located upstream of the common neutral sinking point. Alternatively, the device must monitor the combined four-wire rectifier and split-bypass input currents.

The residual earth current introduced by the RFI suppression filter inside the UPS is greater than 3.5mA and less than 860mA. Liebert recommends verifying the selectivity with all other differential devices both upstream of the input distribution board and downstream (toward the load).

### 1.5.2 External Battery

The UPS and its associated batteries are protected against overcurrents through a DC compatible disconnect device.

### 1.5.3 UPS Output

Any external distribution board used for load distribution shall be fitted with protective devices that discriminate with those used at the bypass input to the UPS and with the UPS overload characteristics (see **Table 35**).

## 1.6 Power Cables

The cable design must comply with the voltages and currents provided in this section, follow local wiring practices and take into consideration the environmental conditions (temperature and physical support media).

For cable entry terminal, refer to **Figure 22**.



### WARNING

Before starting the UPS, ensure that you are aware of the location and operation of the external isolators that connect the ups input/bypass supply to the mains distribution panel. Check that these supplies are electrically isolated and post any necessary warning signs to prevent their inadvertent operation.



### WARNING

Failure to follow adequate earthing procedures may result in electromagnetic interference or in hazards involving electric shock and fire.

**Table 1 Maximum steady state AC and DC currents**

UPS Rating (kVA)	Nominal Current, Amps							Busbar Stud Size			
	Input Mains Current <sup>1,2</sup> With Full Battery Recharge 3ph + N			Output Current <sup>2</sup> at Full Load 3ph + N			Battery at End of Discharge	Input/Output/ Bypass Cables		External battery Cables (Bolts)	Torque Load (Nm)
	380V	400V	415V	380V	400V	415V		Bolt	Hole Dia. (mm)		
10	22	21	20	15	14	13	22	M6	6	M6	5
15	33	32	31	22	21	20	33				
20	44	43	42	30	29	28	44				
30	63	62	61	45	44	42	66				

1. Input mains current listed for common rectifier and bypass AC input. For split input the rectifier current is 94% of the currents listed.
2. Non-linear loads (switch mode power supplies) affect the design of the output and bypass neutral cables. The current circulating in the neutral cable may exceed the nominal phase current. A typical value is 1.5 In.
3. Protective earth cable: Connect each cabinet to the main ground system must follow the most direct route possible. The earth conductor shall be sized in accordance with the AC supply fault rating, cable lengths and type of protection. Typical cross sectional areas are 2.5mm<sup>2</sup> (10kVA), 6mm<sup>2</sup> (15kVA), 10mm<sup>2</sup> (20kVA), 16mm<sup>2</sup> (30kVA), as per AS / IEC 60950-1
4. When sizing battery cables, a maximum volt drop of 4 VDC is permissible at the current ratings given in **Table 1**. The load equipment is generally connected to a distribution board containing individually protected busbars rather than connected directly to the UPS output. The output cables from paralleled units to the parallel distribution bus should be of same length so as to optimise the sharing of current. Do not form coils, so as to minimise the formation of electromagnetic interference.
5. For terminal location – refer to **4.0 - Installation Drawings**)

**Table 2 Distance from floor to connection point on the equipment**

UPS	Minimum Distance mm (in.)
Rectifier A.C. Input supply	284 (11-1/5)
Bypass A.C. Input supply	284 (11-1/5)
UPS Output A.C.	369 (14-1/2)
Battery Power	369 (14-1/2)
Auxiliary cables: Monitor board (U2)	1104 (43-1/2)



### 1.6.1 Cable Termination



#### **NOTE**

*The operations described in this section must be performed by authorised electricians or qualified technical personnel. If you have any difficulties, do not hesitate to contact our Customer Service and Support Department. See the back page of this manual for contact information.*

Once the equipment has been finally positioned and secured, connect the power cables as described in the following procedure.

Refer to the appropriate cable connection drawing in **4.0 - Installation Drawings**.

1. Verify that the UPS equipment is isolated from its external power source and all the UPS power isolators are open. Check that these supplies are electrically isolated and post any necessary warning signs to prevent their inadvertent operation.
2. Open the door to the UPS cabinet and remove the front protective cover to gain access to the connections bars.
3. Connect the safety earth and any necessary bonding earth cables to the copper earth busbar located on the floor of the equipment below the power connections. All cabinets in the UPS must be connected to the user's ground connection.



#### **NOTE**

*The earthing and neutral bonding arrangement must be in accordance with local and national codes of practice.*

Identify and make power connections for incoming cables according to one of the two procedures below, depending on the type of installation.

#### **Common Input Connections**

4. For common bypass and rectifier inputs, connect the **AC input supply** cables between the mains distribution panel and the UPS **input** (mA-mB-mC-N terminals) and tighten the connections to 5Nm (M6 Bolt). **Ensure correct phase rotation.**

#### **Split-Bypass Connections**

5. If a split-bypass configuration is used, connect the AC input supply cables to the rectifier input busbars (mA-mB-mC-N terminals) and the AC bypass supply cables to the bypass input (bA-bB-bC-N terminals) and tighten the connections to 5 Nm (M6 Bolt). **Ensure correct phase rotation.**



#### **NOTE**

*For split-bypass operation, ensure that the linking busbars between bypass and rectifier input are removed.*

*The AC input and the AC bypass supplies must be referenced to the same neutral point.*

#### **Frequency Converter Mode**

If a frequency converter configuration is used, connect the AC input supply cables to the rectifier input busbars (U1-V1-W1-N terminals) to 5Nm for M6 bolts, to 13Nm for M8 bolts or to 26Nm (M10 bolt). **Ensure correct phase rotation and tighten the connections.** There will not be any AC bypass supply cables to the bypass input (U3-V3-W3-N terminals).



#### **NOTE**

*For frequency converter operation, ensure that the linking busbars between bypass and rectifier input are removed.*

### Output System Connections

6. Connect the system **output cables** between the **UPS output** (oA-oB-oC-N terminals) and the **critical load** and tighten the connections to 5 Nm (M6 Bolt). **Ensure correct phase rotation.**



## WARNING

If the load equipment will not be ready to accept power on the arrival of the commissioning engineer, ensure that the system output cables are safely isolated at their ends.

### Internal UPS Battery Connection

7. The battery consists of a series string connection of 5 x 8 (or 10) x 12V 6-cell battery blocks.
  - a. Ensure that the 8 (or 10) battery blocks in each tier (tray) are interconnected.
  - b. Connect the positive, neutral and negative cables to the UPS terminals.
  - c. Plug in the cables between the tiers.
  - d. Ensure correct polarity battery string series connections (i.e., intertier and interblock connections are from positive to negative terminals).



## WARNING

### Hazardous Battery Terminal Voltage 480VDC

Ensure correct polarity of string end connections to the UPS terminals, i.e., positive to positive, negative to negative and neutral to neutral, but leave these UPS terminal cables disconnected until connection is authorised by the commissioning engineer.

Ensure correct polarity of string end connections to the battery circuit breaker and from the battery circuit breaker to the UPS terminals, i.e., positive to positive and negative to negative, but disconnect one or more battery cell links in each tier.

Do not reconnect these links and do not close the battery circuit breaker before authorised by the commissioning engineer.

8. Refit all protective covers removed for cable installation.

## 1.7 Control Cables and Communication

### 1.7.1 Monitor Board Features

Based on your site's specific needs, the UPS may require auxiliary connections to manage the battery system (external battery circuit breaker, battery temperature sensor), communicate with a personal computer or provide alarm signaling to external devices or for Remote Emergency Power Off (REPO). The monitor board, arranged for this purpose, is located on the rear of the operator access door. The main features are:

- Input and Output dry contacts signal (one pair of contacts of relay)
- Emergency Power Off control (EPO)
- Environmental parameter input interface
- User communication (for data setting and user background monitor)
- Intellislot™ interface
- Modem interface
- Temperature detect interface

Figure 2 Auxiliary terminal block detail monitoring board (U2)

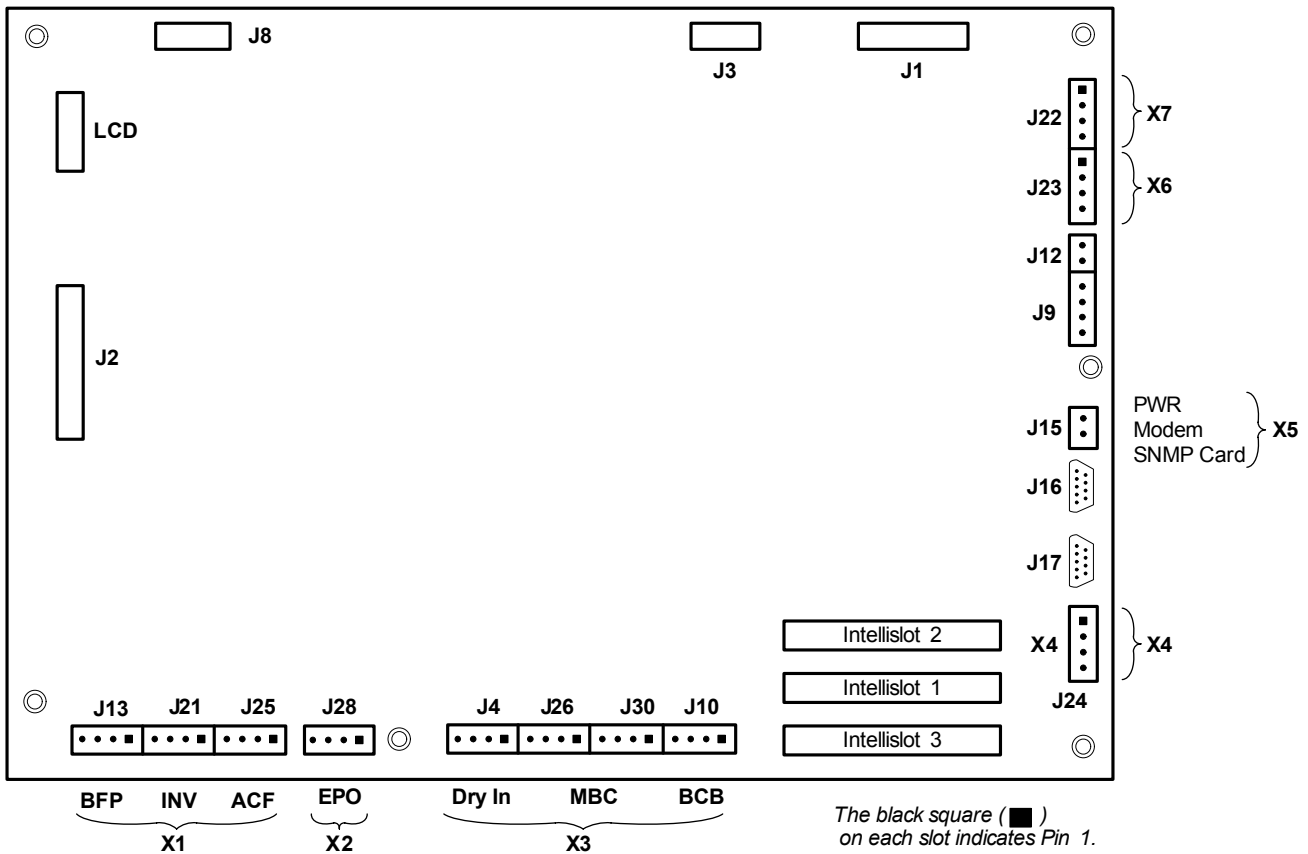

## 1.8 Dry Contacts

The UPS provides input dry contacts and output dry contacts.

### 1.8.1 Input Dry Contacts

There are several input dry contacts at the X3 slot.

Figure 3 Input dry contacts

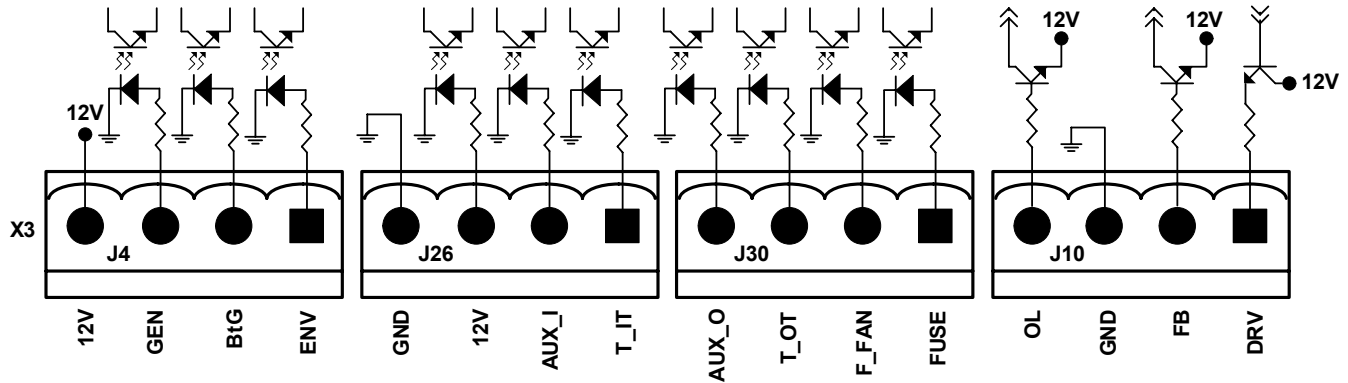

### X3 Ancillary Control and Alarms

#### X3 IN DRY: Environmental, Battery Ground Fault and Generator Contacts

The UPS accepts external signalling from voltage-free (dry) contacts connected to finger-proof, push-in terminal X3 IN DRY. Subject to prior software programming, the signalling is accepted by the UPS when connection between the relevant terminal and the +12V terminal is altered. Cables connected to X3 IN DRY must be segregated from power circuits (for screening purposes), double insulated and of a typical 0.5 to 1mm<sup>2</sup> cross-section area for maximum runs between 25 and 50 meters (82-164 ft), respectively.

Table 3 Input dry contacts at X3

Position	Name	Description
J4.1	ENV <sup>3</sup>	Battery Room Alarm (NC)
J4.2	BtG	Battery Ground Fault Detection (NC)
J4.3	GEN <sup>1,2</sup>	On Generator (NO)
J4.4	+12V	+12V Power

1 - Must be configured by configuration software before becoming active.

2 - When activated, the charger current can be limited, via software, to a percentage of the full charger current (0-100%).

3 - Activating this feature turns the battery charger off.

### 1.8.2 Maintenance Bypass Cabinet Interface

J26 and J30 are the MBC interface.

Table 4 Maintenance bypass cabinet interface

Position	Name	Description
J26.1	T_IT <sup>1</sup>	Input transformer overtemperature (NC)
J26.2	AUX_I	Reserved
J26.3	+12V	+12V Power
J26.4	GND	Power Ground
J30.1	FUSE	Reserved
J30.2	F_FAN	Fan Fail Alarm (NC)
J30.3	T_OT <sup>1</sup>	Output Transformer Overtemperature (NC)
J30.4	AUX_O	Reserved

<sup>1</sup> - Must be configured by software before becoming active



#### NOTE

All auxiliary cables of terminal must be double-insulated. Wire should be 0.5-1.5mm<sup>2</sup> (16-20AWG) stranded for maximum runs between 25 and 50 meters (82-164ft.) respectively.

### 1.8.3 External Circuit-Breaker Interface

J10 is the interface to any external battery circuit breaker (BCB).

**Table 5 External circuit-breaker interface**

Position	Name	Description
J10.1	DRV	BCB Driver Signal - (reserved)
J10.2	FB	BCB Contact State -(reserved)
J10.3	GND	Power Ground
J10.4	OL	BCB On-Line - Input - This pin will become active when BCB interface is connected. (N.O.)



**NOTE**

*All auxiliary cables of terminal must be double-insulated. Wire should be 0.5-1.5mm<sup>2</sup> (16-20AWG) stranded for maximum runs between 25 and 50 meters (82-164ft.) respectively.*

**Figure 4 Jumper connection for BCB interface**

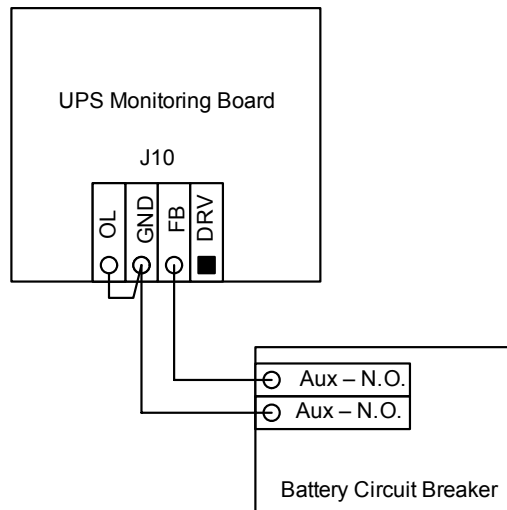

### 1.8.4 Output Dry Contacts

There are three output dry contact relays at the X1 slot (see **Figure 5** and **Table 6**)

**Figure 5** Output dry contacts and EPO wiring

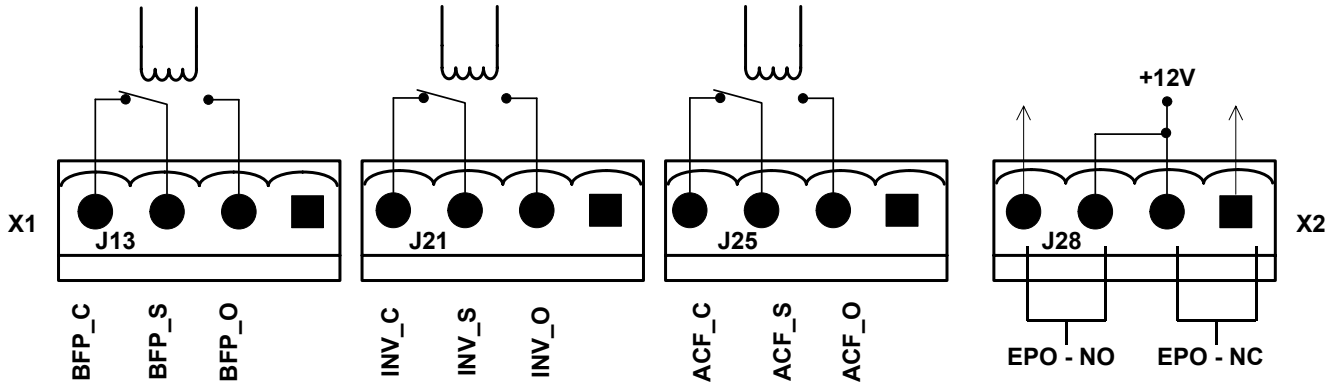

**Table 6** Output dry contact relays

Position	Name	Description
J13.2	BFP_O	Bypass feedback protection relay; normally open; closed when bypass SCR is shorted
J13.3	BFP_S	Bypass feedback protection relay center
J13.4	BFP_C	Bypass feedback protection relay; normally closed; open when bypass SCR is shorted
J21.2	INV_O	Inverter mode relay; normally open; closed when UPS is in inverter mode
J21.3	INV_S	Inverter mode relay center
J21.4	INV_C	Inverter mode relay; normally closed. Opened when UPS is in inverter mode
J25.2	ACF_O	Main input fault relay; normally open. Closed when main input is in fault
J25.3	ACF_S	Main input fault relay center
J25.4	ACF_C	Main input fault relay; normally closed. Open when main input is in fault



**NOTE**

All auxiliary cables of terminal must be double-insulated. Wire should be 0.5-1.5mm<sup>2</sup> (16-20AWG) stranded for maximum runs between 25 and 50 meters (82-164ft.) respectively.

### 1.8.5 Emergency Power Off Input

The UPS has an Emergency Power Off (EPO) function that operates by a button on the control panel or by a remote contact provided by the user. The EPO button is under a hinged, clear plastic shield.

The X2 slot, shown in **Figure 5**, is the remote EPO input interface. The EPO has an NO/NC contact point that becomes active when shorting terminals X2: 3 and 4 or open terminal connection X2: 2 and 1

If an external emergency stop facility is required, it is connected terminals X2: 1&2 or X2: 3&4 of the auxiliary terminal block (X2). It also is connected to the normally open or normally closed remote stop switch between these two terminals using shielded cable (see **Figure 5** and **Table 7**). If this function is not used, terminals X2: 3&4 must be opened and X2: 1&2 must be closed.

**Table 7 EPO input contact relays**

Position	Name	Description
J28.1	EPO_NC	EPO activated when opened to J28.2
J28.2	EPO_NC	EPO activated when opened to J28.1
J28.3	EPO_NO	EPO activated when shorted to J28.4
J28.4	EPO_NO	EPO activated when shorted to J28.3



**NOTE**

*The emergency stop action within the UPS shuts down the rectifier, inverter and static bypass. It does not internally disconnect the input power supply. To disconnect ALL power to the UPS, open the upstream feeder breaker(s) when the remote EPO is activated.*



**NOTE**

*Normally closed EPO – X2: 1,2, these terminals are supplied factory-linked on the monitor board and must remain installed if using NC contacts.*



**NOTE**

*All auxiliary cables of terminal must be double-insulated. Wire should be 0.5-1.5mm<sup>2</sup> (16-20AWG) stranded for maximum runs between 25 and 50 meters (82-164ft.) respectively.*

### X5: Auxiliary DC Power Output

Auxiliary DC power for modem or external SNMP card. The voltage is between 9V to 12V. The maximum current is 500mA.

### X6: Analog Input Interface

Two analog signal channels with an input range is from 0 to +12V. The precision of detection is ±3%.

- X6 pin 1: Not used
- X6 pin 2: +12V
- X6 pin 3: ENV-T – environment temperature detection
- X6 pin 4: GND

### X7: External Battery Temperature Detector Interface

Interface for TMP12Z temperature detector, normally connected to an external battery cabinet (see **Figure 7**).

Pin reference:

- X7 pin 1: Not used
- X7 pin 2: +12V (Power supply for Temperature Monitoring Probe)
- X7 pin 3: BAT-T (Battery Temperature signal)
- X7 pin 4: GND

### Serial Ports RS232-1 and RS232-2

RS232-1 provides serial data and is intended for direct use with Liebert MultiLink monitoring and server shutdown software.

RS232-2 provides serial data and is intended for use by authorized commissioning and service personnel.

These serial ports are shared with the optional Web browser, SNMP, ModBus and relay cards. Refer to **Table 28** regarding compatibility of simultaneous use.

### Intellislot Web Browser, SNMP, ModBus and Relay Cards Interface

There are three interface slots available for optional Web browser, SNMP, ModBus and Relay cards as illustrated in **8.0 - Options—For Assembly Inside the UPS Cabinet**.

## 1.8.6 External Bypass Switch Interlock

**EXT-Maint X3-1&2** on UPS Parallel Board M3 (leave open if no external bypass switch is used)

Provides external maintenance bypass interlock protection for the UPS. Short circuit means external bypass closed.

**EXT-Out (X3-3&4)** on UPS Parallel Board (leave shorted if no external output switch is used). Provides external output interlock protection for paralleled UPS modules. Short circuit means external output switch closed.



#### NOTE

*UPS Parallel Board M3 is located behind protective covers accessible after opening the UPS front door – removal of this barrier requires the use of a tool and is restricted to service personnel.*



#### NOTE

*Jumper JP1 (located next to X3) needs to be removed for X3:3&4 to work properly.*

## 1.8.7 Battery Start Facility

1. Rotate the switch to Normal Mode.
2. Verify that the batteries are connected.
3. Press Battery Start Button.

The LCD begins to show startup screens. The rectifier indicator flashes green while the rectifier is starting up. It stops flashing and becomes solid green about 30 seconds after the rectifier enters the normal operation state.

4. After UPS has initialized, press Inverter On

**Figure 6 Battery start for UPS**

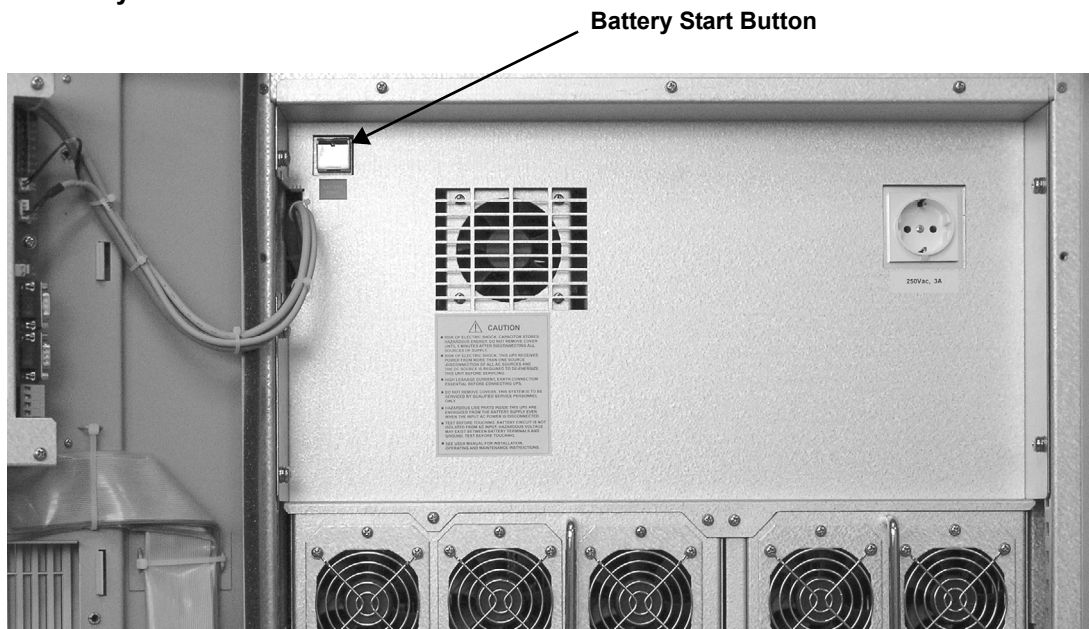



## 2.0 BATTERY INSTALLATION

---

### 2.1 Introduction

The UPS battery bank consists of battery blocks connected in series to provide a D.C. string voltage as required by the UPS converter. The 'AUTONOMY TIME' (the time during which the battery can maintain supply to the load in the event of a mains failure) is limited by the ampere-hour capacity of the battery blocks and in some cases this results in several strings being connected in parallel.

The NX usually has internal batteries, but longer run time is available by using an external battery cabinet.

The battery cabinet will be supplied in one of the following forms:

1. Complete installation, comprising the battery cabinet, batteries and protective device.
2. Battery cabinets and protective device only—batteries supplied by others



#### **NOTE**

*10kVA to 30kVA UPS models contain an internal battery compartment that can accommodate up to 44 blocks of batteries for 12Ah/12V; 80 blocks of batteries for 7.2Ah/12V*

The battery bank may be disconnected from the UPS for maintenance or service.

## 2.2 Safety

Special care should be taken when working with the batteries associated with the Liebert NX UPS system. When all the cells are connected together, the battery terminal voltage is potentially hazardous. The battery installation must be segregated from all but appropriately qualified maintenance personnel by locating the cells in a key-lockable cabinet or in a purpose-designed, dedicated battery room. When the batteries require maintenance, these precautions must be taken:

- The rotary switch must be turned to Maint. position.
- The input circuit breaker (CB1) must be opened.
- The ANDERSON connector must be disconnected..



### NOTE

*The fuse on the battery EMI board (UHA241A2-10kVA, UHK241A2-15/20kVA, UHS242A2-30kVA) is 600VDC/30A, High Speed Fuse.*



### NOTE

*Full safety instructions concerning the use and maintenance of UPS batteries are provided in the appropriate battery manufacturers manuals. The battery safety information contained in this section relates to key considerations that must be taken into account during the installation design process and might affect the design outcome depending on localised conditions.*



## WARNING

### Hazardous battery voltage present behind covers

No user-serviceable parts are located behind covers that require a tool for their removal. Only qualified service personnel are authorised to remove such covers.

When using internal batteries in 10 to 30kVA units, the batteries are always connected through power fuses to the UPS and to the segregated terminal bars available for connection to an external battery.

Isolate any internal battery connections before attempting to access the segregated terminal bars available for connection to an external battery.

The following general battery safety precautions and warnings should be observed at all times:

- A battery can present risk of electric shock or burn from high- short-circuit currents.
- The full nominal string voltage, when the battery blocks are interconnected, is 480VDC, which is hazardous
- Only qualified personnel should install or service batteries.
- Eye protection should be worn to prevent injury from electrical arcs.
- Remove rings, watches, necklaces, bracelets and all other metal objects.
- Use only tools with insulated handles.
- Wear rubber gloves and a rubber apron when handling batteries.
- If a battery leaks electrolyte or is otherwise damaged, it should be placed in a container resistant to sulfuric acid and disposed of in accordance with local regulations.
- If electrolyte comes into contact with the skin the affected area should be washed immediately with plenty of clean water.
- Batteries must always be disposed of according to local environmental laws.
- When replacing batteries, use the same number and type that were originally fitted.
- Disconnect charging source before connecting or disconnecting battery terminals.
- Determine whether the battery is inadvertently grounded. If it is inadvertently grounded, remove the source of the ground. Contact with any part of a grounded battery can result in electrical shock.

## 2.3 Battery Cabinet

### 2.3.1 Introduction

This cabinet can also be used in conjunction additional cabinets, to provide the necessary accommodation required by the larger cells associated with system's having a long autonomy time.

Where two (or more) cabinets are used they are positioned alongside each other and secured and bonded together. If the cabinet(s) is located immediately adjacent to the main UPS equipment the two units are bolted together.

### 2.3.2 Temperature Considerations

Valve-regulated, lead acid battery cells are sensitive to ambient temperature and should be operated between 15°C and 25°C (59-77°F). Battery capacity is increased by 1% for every 1°C (2°F) increase in temperature up to 25°C (77°F). Battery life is reduced at temperatures above 25°C (77°F).

When batteries are mounted in the same room as the UPS unit, it is the battery that dictates the designed maximum ambient temperature, not the UPS. — i.e. in the case of valve-regulated cells, the ambient room temperature should be kept between 15°C and 25°C (59-77°F), and **not** between 0°C and 40°C (32-104°F) (which is the specified main equipment operating temperature range). Temperature deviations are permissible for short periods, provided the average temperature does not exceed 25°C (77°F).

### 2.3.3 Dimensions

The external dimensions are shown in **Table 8**. These are the same height and depth as the UPS module and provide a matching appearance when bolted together. All cabinets are fitted with doors, which must be fully opened in order to fit or remove the batteries. The door swing must therefore be taken into consideration when planning the positioning of the cabinets.

### 2.3.4 Weight

The unladen weight is shown below in **Table 8**. When designing the battery installation the weight of the batteries and cables must be added to the unladen weight. This is particularly important when placing the NX on a raised floor.

**Table 8 Dimensions and weight**

Model	Optional Circuit Breaker Amperes	Maximum Discharge Current (at EOD)	External Cabinet WxDxH mm (in)	Cabinet Weight Without Batteries kg (lb)
Battery Cabinet	50A	10kVA 22A 15kVA 33A 20kVA 44A	820x700x1400 (32-1/4x27-5/8x55)	170 (375)
	80A	30kVA 66A		

### 2.3.5 Circuit Isolator Features

The UPS is fitted with Anderson connectors and fuses for connection and disconnection of internal batteries. External battery banks require battery fuses or circuit breaker (with optional status contacts). Refer to **1.8.3 - External Circuit-Breaker Interface** for details.

### 2.3.6 Battery Temperature Sensor (Optional)

The optional external battery temperature sensor kit contains one probe and one temperature transport board as illustrated in **Figure 7**. It is connected to the UPS Monitor Board.

**Figure 7** Single temperature sensor and monitor board-U2

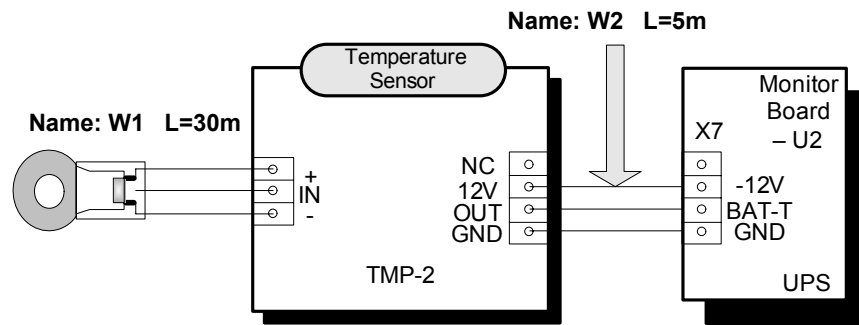

Cable W2 is packed with the temperature sensor.

### 2.3.7 Moving the Battery Cabinets



## WARNING

Ensure any lifting equipment used in moving the cabinet has sufficient lifting capacity.

Ensure that the weight is within the designated surface weight loading of any handling equipment. See **Table 8** for weight details.

Battery cabinets can be handled by means of a fork lift or similar equipment.



## NOTE

*Care must be taken when maneuvering units fitted with batteries. Keep such moves to a minimum.*

*When the equipment has been finally positioned ensure the adjustable feet are set so that the battery cabinet will remain stationary and stable.*

Seismic anchors option is available for anchoring the unit to a concrete floor.

### 2.3.8 Cable Entry

Cables enter the battery cabinet from the bottom. Cable entry is made possible by removing a blanking piece fitted at the bottom to reveal the cable entry hole.

### 2.3.9 General Arrangement Drawings

Refer to **Figures 8 and 10** for general arrangement of battery cabinet models.

**Figure 8 Battery cabinet bottom cable entry location**

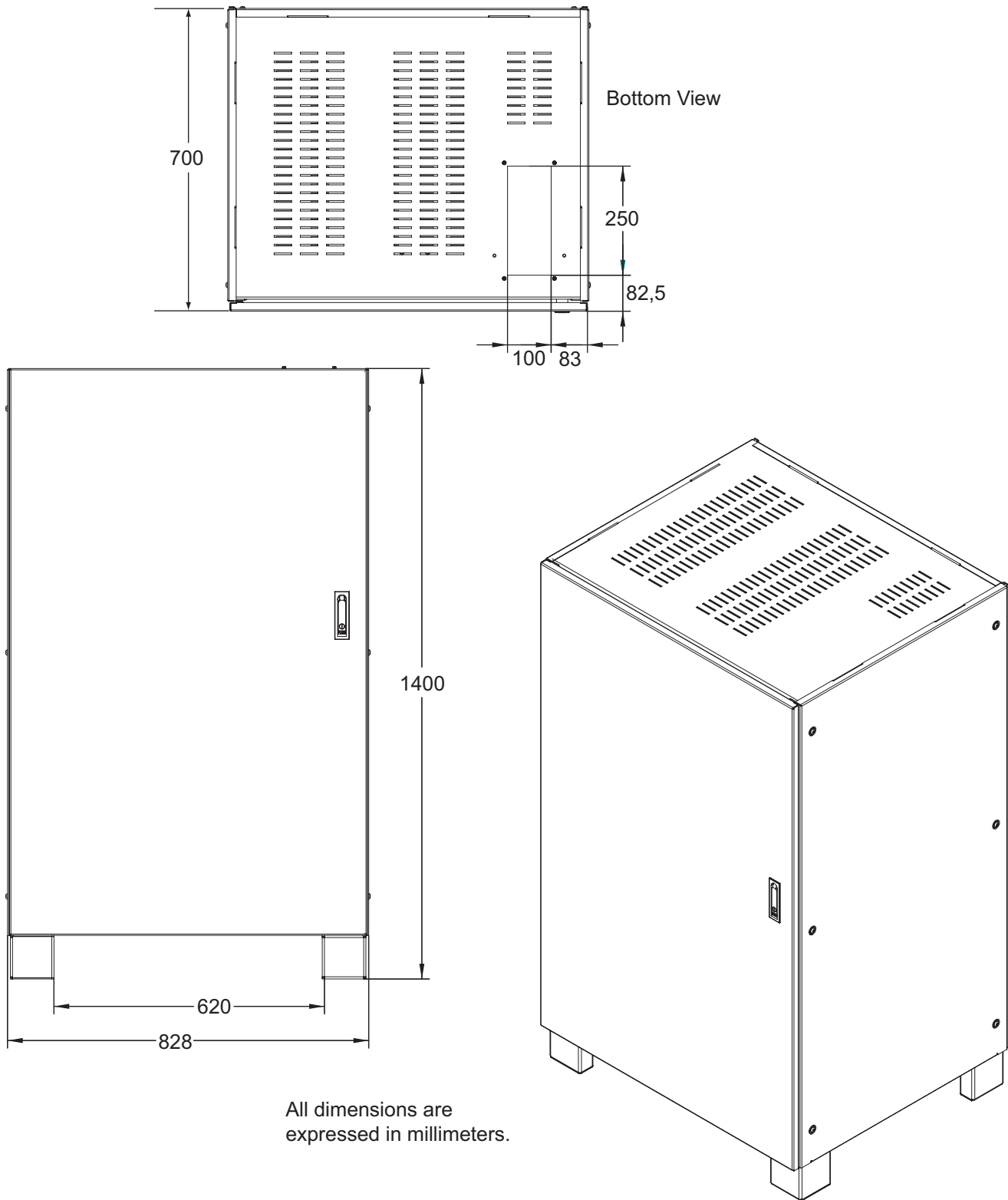

All dimensions are expressed in millimeters.

Figure 9 Battery cabinet with fuse or optional circuit breaker locations

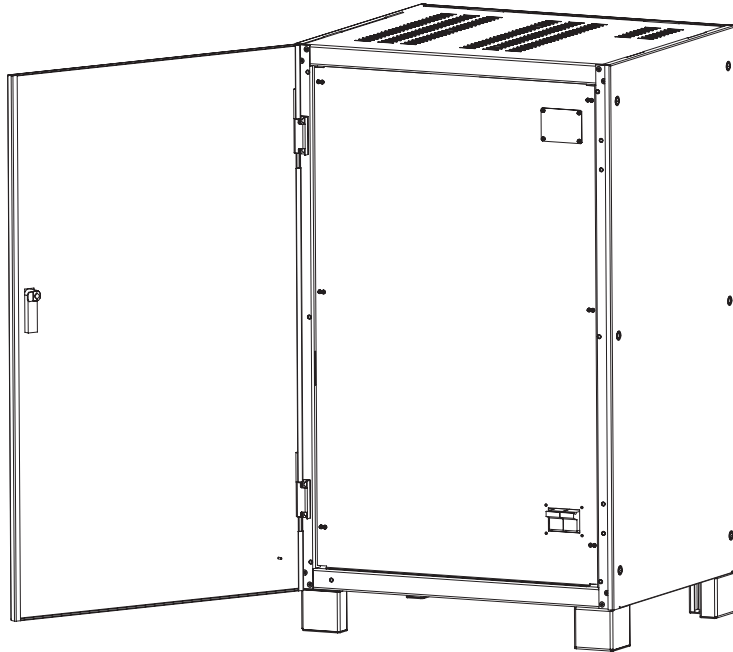

Bottom cable entry

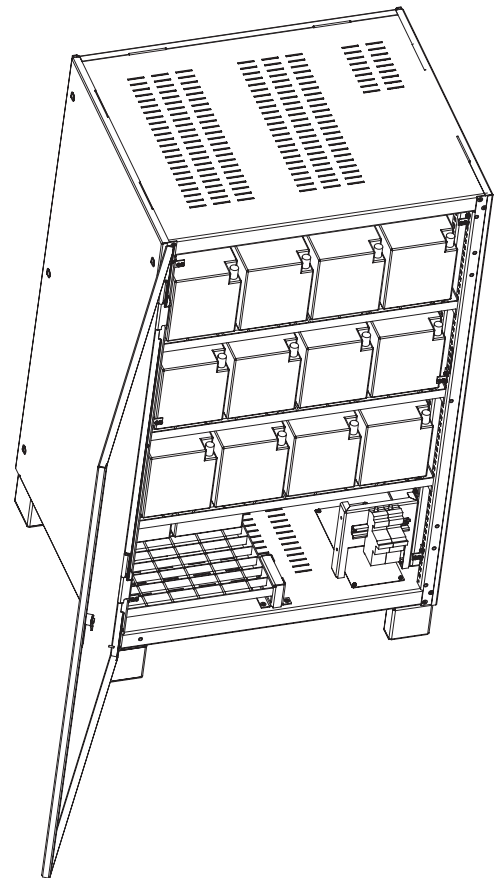
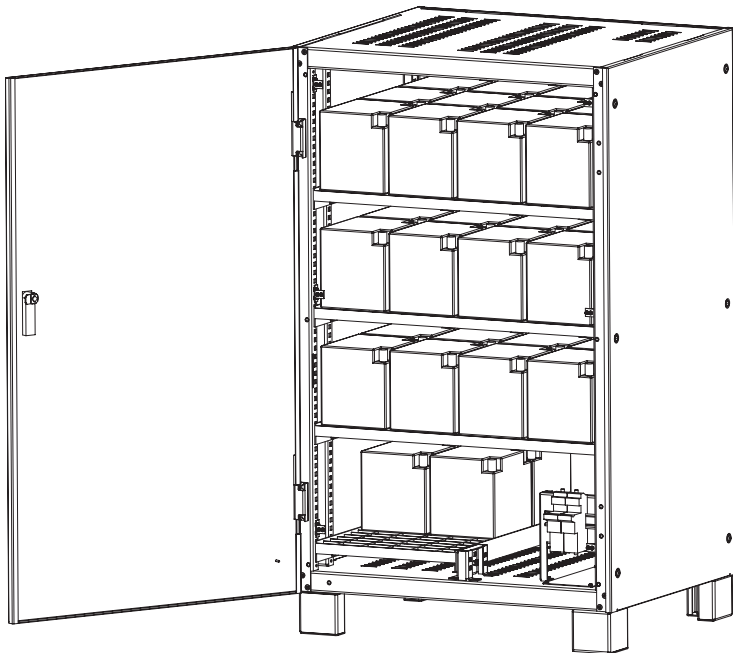
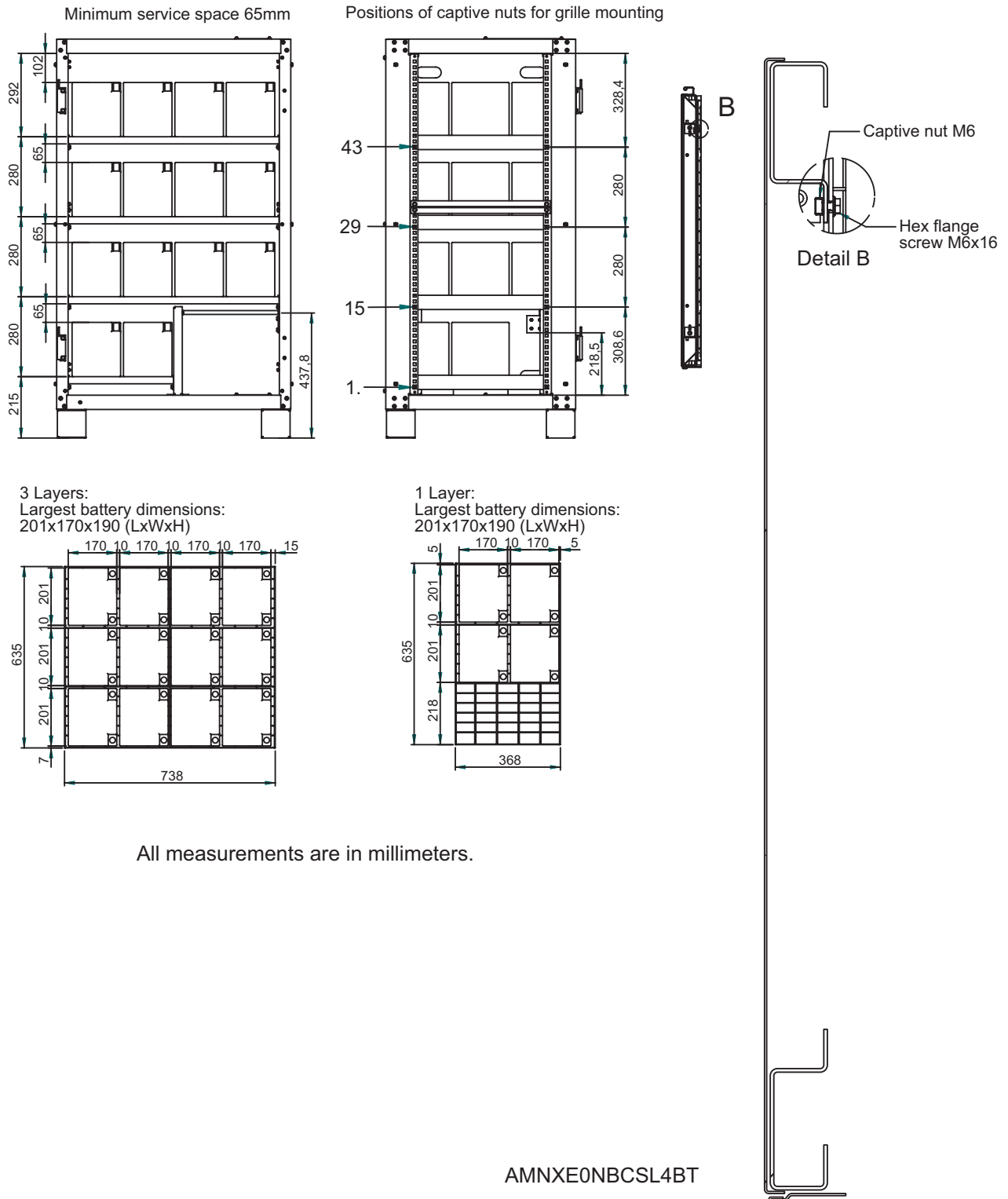
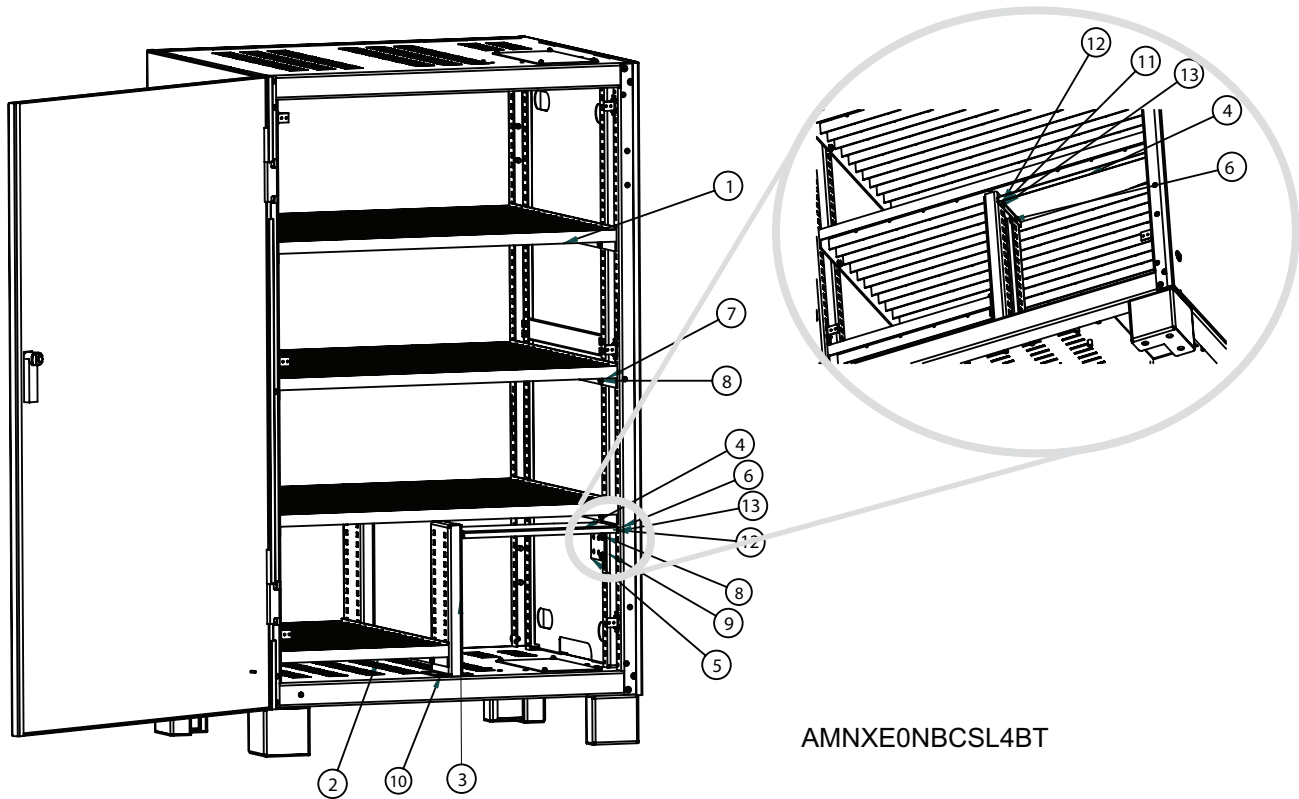

Figure 10 Battery cabinet internal layout



All measurements are in millimeters.

Figure 11 Battery cabinet, bottom entry



AMNXE0NBCSL4BT

Item #	Item Name
1	Grille steel
2	Grille steel
3	Middle pillar
4	Cover module BC Small NXe
5	Ground bus
6	Captive nut M4
7	Captive nut M6
8	Screw flange M6x16
9	Nut flange M6
10	Screw M6x16 countersink
11	Spring washer M4
12	Flat washer M4
13	Screw mushroom head cross M4x12

## 2.4 Battery Power Cables

### 2.4.1 Connection Principles

The following notes, in conjunction with the diagrams, illustrate the broad principles to be followed when fitting and connecting the majority of battery installations.



### 2.4.2 Fitting the Batteries

1. In general, at least 10mm (3/8") must be left unobstructed on all vertical sides of the battery blocks to permit free air movement around the cells.
2. Clearance should be allowed between the top of the cells and the underside of the shelf above (this is necessary for monitoring and servicing the cells).
3. When installing the batteries on racks always work from the bottom shelf upwards to prevent raising the centre of gravity.

### 2.4.3 Connecting the Battery

1. When the battery cabinet is installed on a raised floor the battery power cables and optional circuit breaker control cables can be routed to the UPS cabinet via the floor of the cabinet. If the UPS and battery cabinet are located adjacent to each other and located on a solid floor these cables can be passed between the cabinets via the lifting apertures located in the lower sides of the cabinets.
2. In general it is recommended that the inter-connecting cables be fitted to the batteries within their particular level before fitting the inter-level connecting cables, followed finally by the cables to the circuit breaker.
3. An insulating shroud should be fitted to each terminal after its connection has been made.
4. When connecting the cables between the battery string ends to the optional circuit breaker always connect the circuit breaker end of the cable first.

### 2.4.4 Battery Room Design

Whatever the type of mounting system selected, the following conditions should be noted:

- Cell Layout—1  
Whichever battery mounting system is used, the batteries should be arranged to prevent the possibility of simultaneous contact with two exposed live parts having a potential greater than 150V. Where this is not possible, insulated terminal shields must be installed and insulated cables must be used for connections.
- Service Platform—2  
The service platform (or duckboard) must be slip-proof, insulated from the floor and at least one metre (39 in.) wide.
- Connections—3  
All connections must be as short as possible.
- Battery Protection Fuses/Circuit Breaker—4  
The battery circuit breaker is generally installed at the front of the battery room. See **2.5 - Battery Control** for details on connecting the circuit breaker box available for the Liebert NX.

Figure 12 Battery room design

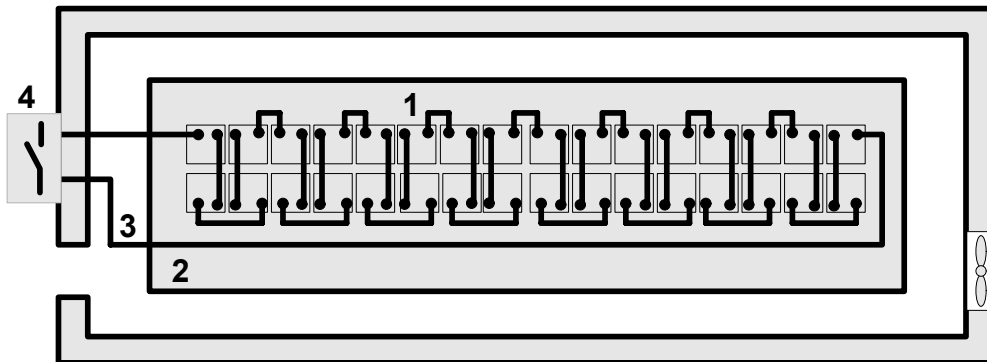

### 2.5 Battery Control

Battery temperature sensor cables are connected between UPS auxiliary terminal block X3 BCB, the Battery Temperature sensor and the battery as shown in **Figure 7**.

Cables connected to X3 BCB must contain a protective earth wire or a shield, be segregated from power circuits, double insulated and of a typical 0.5 to 1mm<sup>2</sup> cross section area for maximum runs between 25 and 50 meters respectively. The shield should be connected to the protective earth of the battery cabinet or battery breaker, not at the UPS

### 3.0 UPS MULTI-MODULE INSTALLATION

#### 3.1 General

The installation of a multi-module UPS configuration must follow the installation procedure for a single UPS module with the additional requirements detailed in this chapter.

In addition to the local EPO push button on the front panel of the UPS module (that stops operation of that module), the UPS supports also a remote emergency stop to permit simultaneous multi-module shutdown.



**NOTES**

1. The remote emergency power off switch must be voltage-free and Normally Open or Normally Closed.
2. The open voltage supplied is 12VDC, < 20mA
3. This external emergency stop may be supplied with a second set of contacts that can be used to trip incoming mains or bypass supply circuit breakers supplied by others and fitted with remote trip units.
4. Normally Closed EPO - X2: 1&2, these terminals are supplied factory-linked on the monitor board.

**Figure 13 Emergency power off connections**

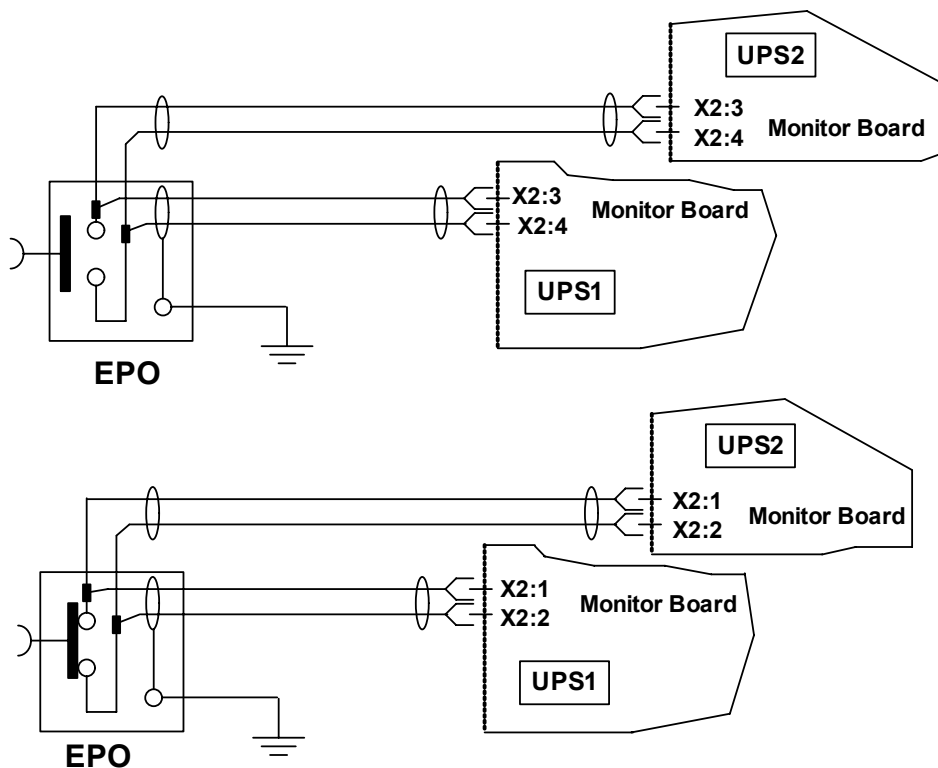

### 3.2 Paralleled UPS Modules

The basic installation procedure of a parallel system comprising two or more UPS modules is the same as that of single module system. The following sections only introduce the installation procedures specific to the parallel system.

#### 3.2.1 Cabinet Installation

Place the UPS modules side by side and interconnect as shown in **Figure 14**. The distribution panel (external bypass cabinet) is optional but recommended for ease of maintenance and system testing.

**Figure 14** Typical 1+N system block diagram with common input supply, with separate batteries and optional output / bypass distribution panel

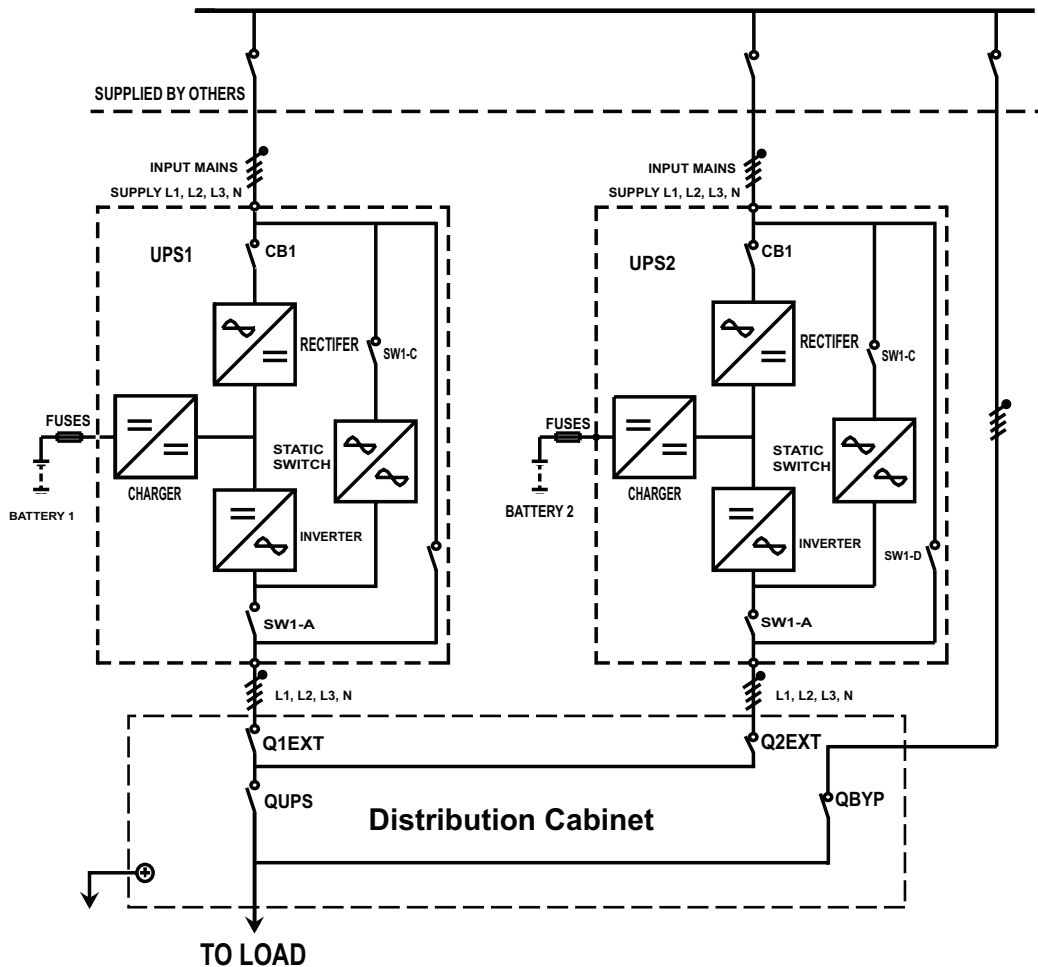
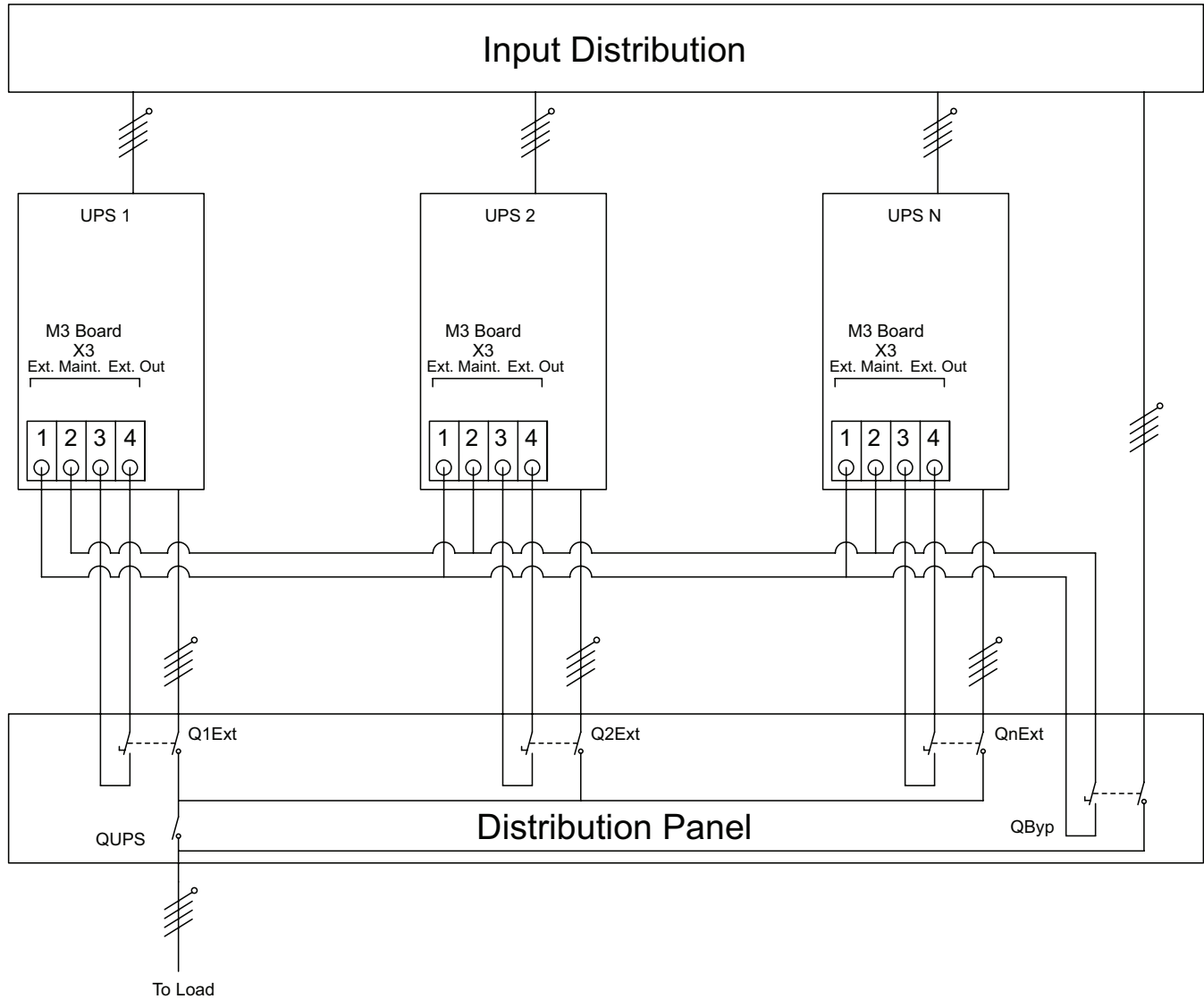

Figure 15 Dry contacts, multiple UPS modules with distribution panel



### 3.2.2 External Protective Devices

Refer to the instructions in **1.0 - Single Module UPS Installation**.

### 3.2.3 Power Cables

The wiring of power cables is similar to that of single module system. The Bypass and the Main input sources must be referenced to the same neutral potential and input earth leakage monitoring devices, if installed, must be located upstream of the common neutral sinking point. Refer to the instructions in **1.0 - Single Module UPS Installation**.



**NOTE**

*The length and specification of power cables including the bypass input cables and UPS output cables should be the same. This facilitates load sharing when operating in bypass mode.*

### 3.2.4 Control Cables

#### Intermodule Control

Shielded and double insulated control cables available in lengths of 5, 10 and 15 meters must be interconnected in a ring configuration between UPS modules as shown below. The parallel control board is mounted on the top, behind protective cover of each UPS module (refer to **Figure 23**). The ring configuration ensures high reliability of the control. Refer to **Figure 16**.

**Figure 16 Connection of 1+N system parallel control cables**

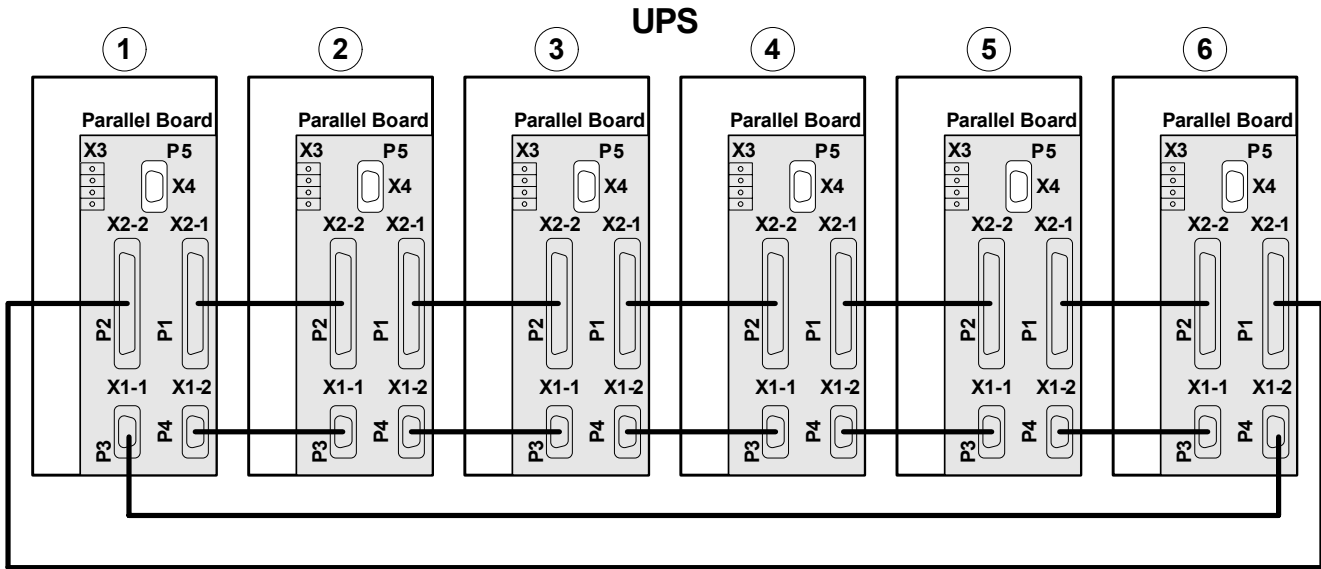

### 3.3 Hot-Standby UPS Modules

#### 3.3.1 Cabinet Installation

Place the UPS modules side by side and interconnect as shown below.

The hot standby mode comprises two series connected UPS modules of the same rating. One module is designated as the hot standby master (downstream), and the other module is designated as the hot standby slave (upstream). Their roles are determined by power connection and configuration software. In normal operation, both slave and master operate in normal mode and the output from one upstream (slave) UPS feeds the bypass input to the other (downstream/master) UPS. The output of the downstream (master) UPS is connected to the critical load and is always synchronised to the output of the upstream (slave) UPS. If the inverter of the UPS connected to the load fails, the inverter of the upstream (slave) UPS supplies the load through the downstream (master) UPS bypass circuit. The system can be programmed to cycle the downstream (master) UPS between normal mode and bypass mode so that both ups are equally exercised.



#### NOTE

*If it is a hot-standby system, the master (downstream) must be turned on first.*

#### 3.3.2 External Protective Devices

Refer to the instructions in **1.0 - Single Module UPS Installation**.

### 3.3.3 Power Cables

The wiring of power cables is similar to that of single module system except that the output of the upstream UPS is fed into the bypass input of the downstream UPS, and the load is fed by the downstream UPS through its inverter or bypass. The bypass and the main input sources must be referenced to the same neutral potential and input earth leakage monitoring devices, if installed, must be located upstream of the common neutral sinking point. Refer to the instructions in **1.0 - Single Module UPS Installation**.

No control wires other than those specified for the single module configuration are required.

**Figure 17 Hot standby configuration**

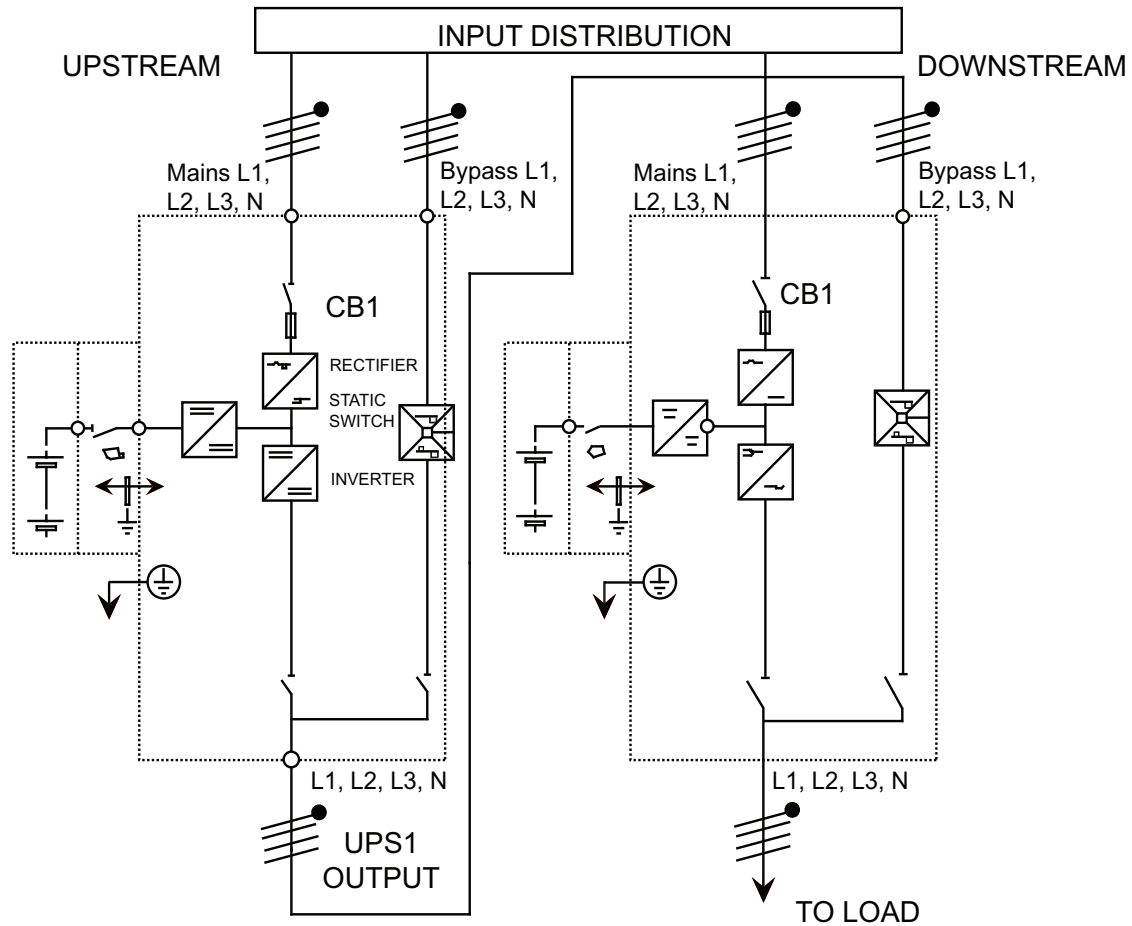

### 3.4 Dual Bus System

#### 3.4.1 Cabinet Installation

The Dual Bus System consists of two independent UPS configurations each consisting of one or more UPS modules. Dual Bus Systems are high availability configurations suitable for loads with multiple input terminals. For single input loads an optional Static Transfer Switch may be added and the standard Load Bus Synchroniser activated. Depending on the configuration, follow the appropriate installation instructions for each system.

Place the UPS modules side by side and interconnect as shown below.

The objective of the Dual-bus Synchronizer (DBS) is to keep the output of two independent UPS systems (or parallel systems) in synchronization. One system is designated as the master; the other is designated as the slave. The operating modes covered comprise master and or slave operating inverter or bypass mode.

**Figure 18 Typical dual bus system configuration with static transfer switch and Load Bus Synch**

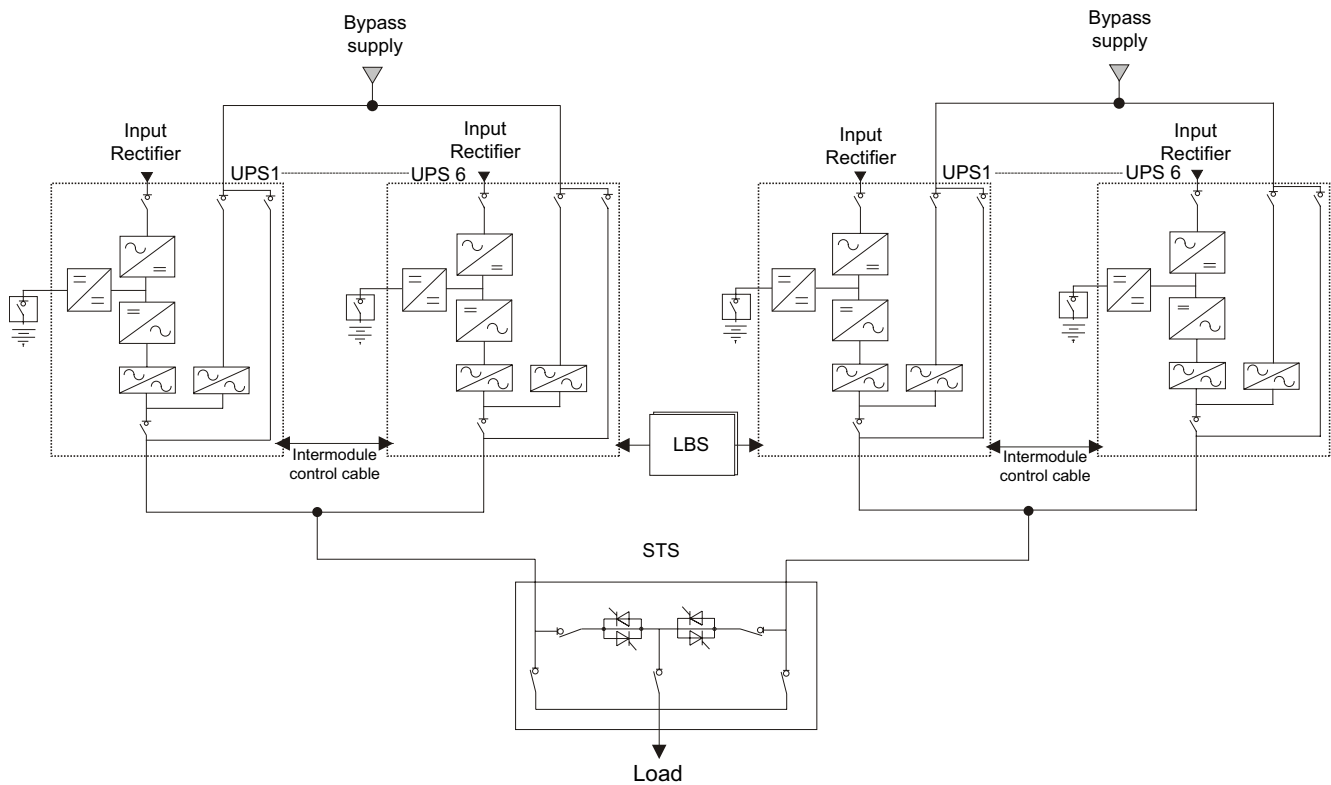

#### 3.4.2 External Protective Devices

Refer to the instructions supplied in **1.0 - Single Module UPS Installation**.

#### 3.4.3 Power Cables

The wiring of power cables is similar to that of single module system. The Bypass and the Main input sources must be referenced to the same neutral potential and input earth leakage monitoring devices, if installed, must be located upstream of the common neutral sinking point. Refer to the instructions in **1.0 - Single Module UPS Installation**

### 3.4.4 Control Wires

For Liebert NX to NX dual bus configuration, interconnect the optional DBS cable between any DBS ports of two parallel systems as illustrated in **Figure 19**.

**Figure 19** Connections of a typical dual bus system utilising Load Bus Synch

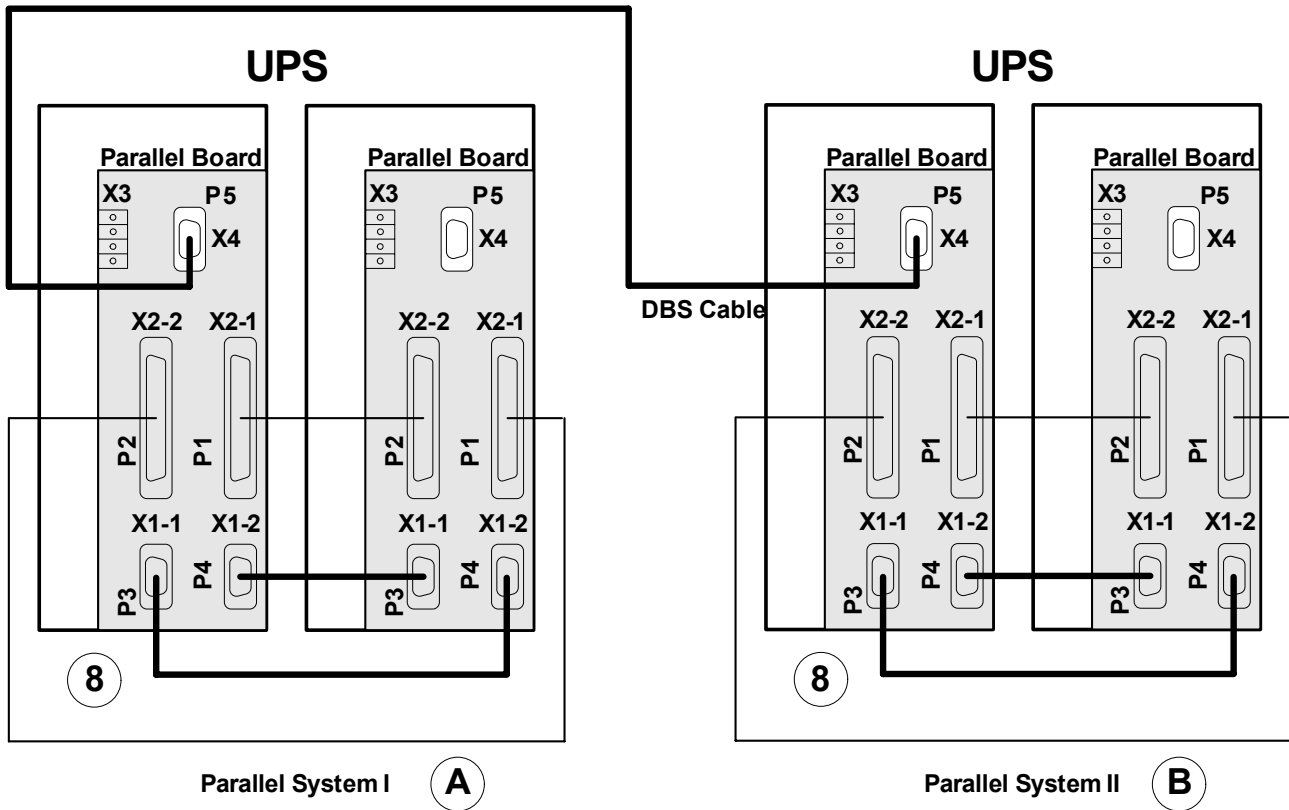

**NOTE**

*Example shown with ring control cables ("8") for DSB applied to two 1+1 paralleled systems.*

### 3.4.5 Extended Dual Bus Synchronization Option (DBS Interface Box)

For Liebert NX to non- NX (whether another Liebert UPS range or not) dual bus configuration, one DBS interface box shall be mounted on the non- Liebert NX UPS. In this situation, the other UPS system is always treated as a master and the following conditions are covered:

- Master and slave are both on inverter
- Master on bypass, slave on inverter



**NOTE**

*Extended DBS interface box is also used for extending DBS cable length up to 150 meters (490ft) for DBS configuration between two groups of NX UPS systems.*



## 4.0 INSTALLATION DRAWINGS

Figure 20 Electrical connections

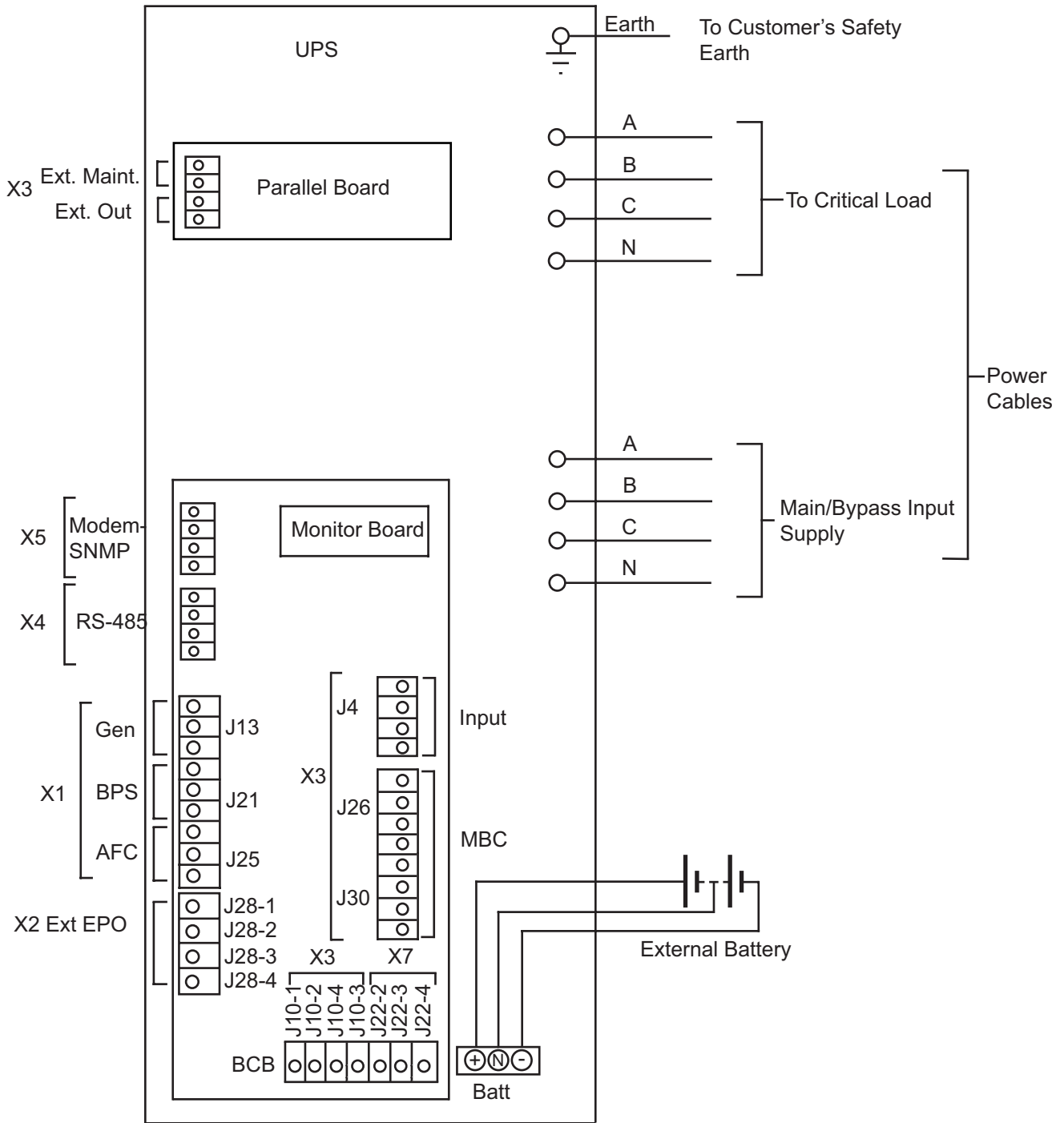
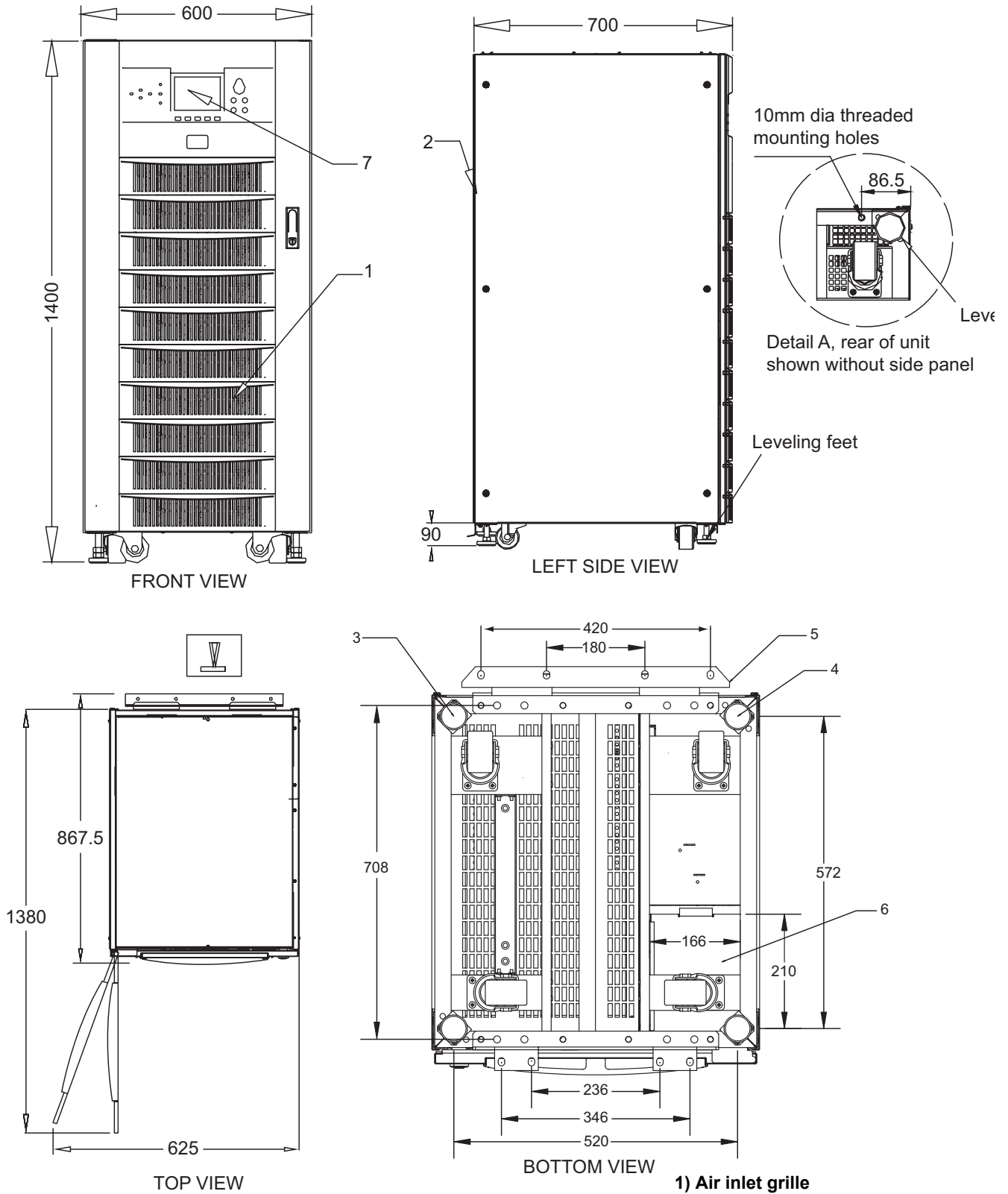

Figure 21 General arrangement—10-30kVA UPS module



All dimensions are in mm.

- 1) Air inlet grille
- 2) Air outlet grille
- 3) Adjustable fixing feet
- 4) Castors for maneuvering
- 5) Seismic anchors (option)
- 6) Cable entry
- 7) Operator control and display panel

Figure 22 10-30kVA NX front view with doors open

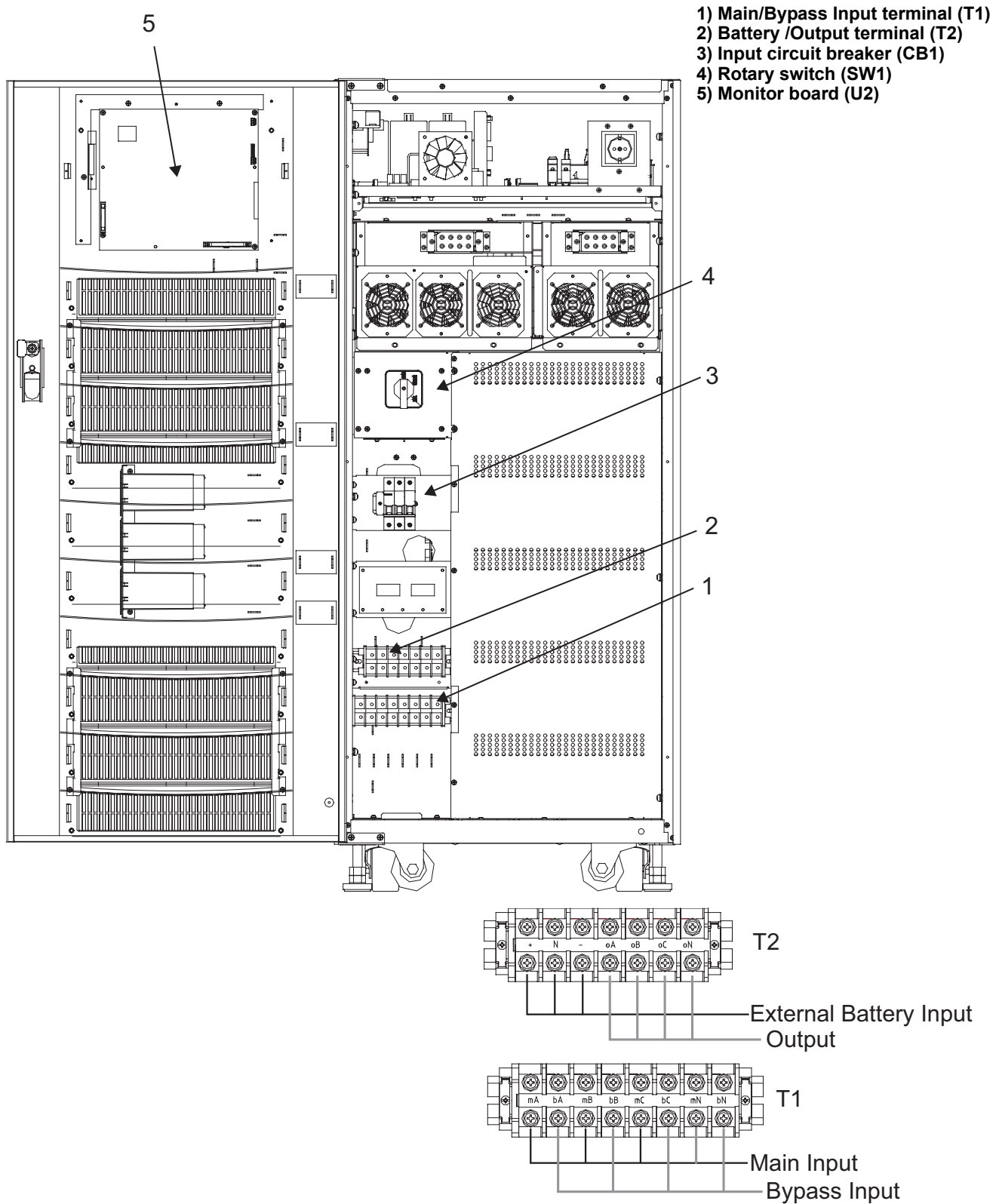
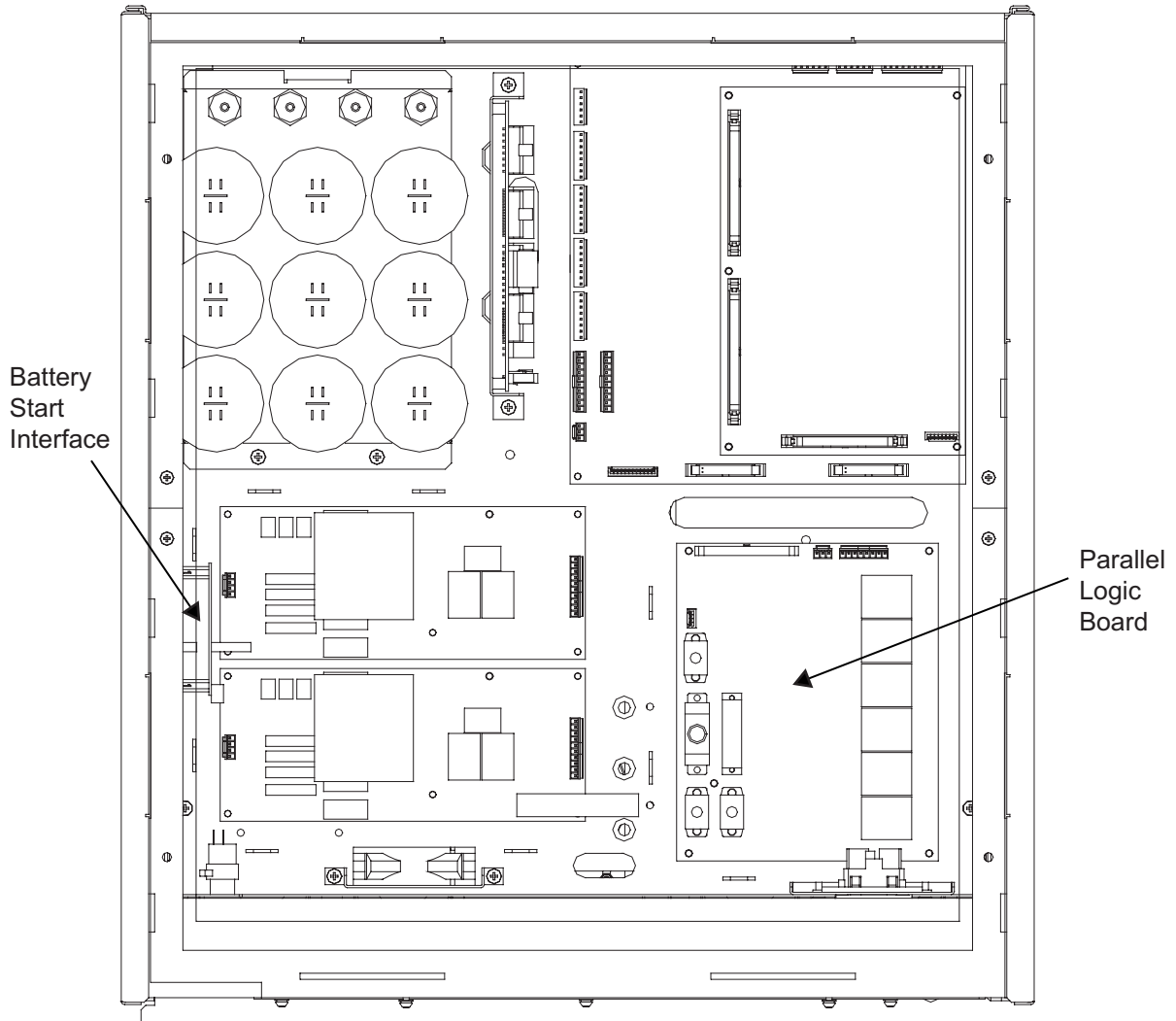

Figure 23 Location of parallel logic board M3



NXe 10-30kVA Top View

Figure 24 Internal battery layout and connecting—GP12120 F2 (12AH/12V)

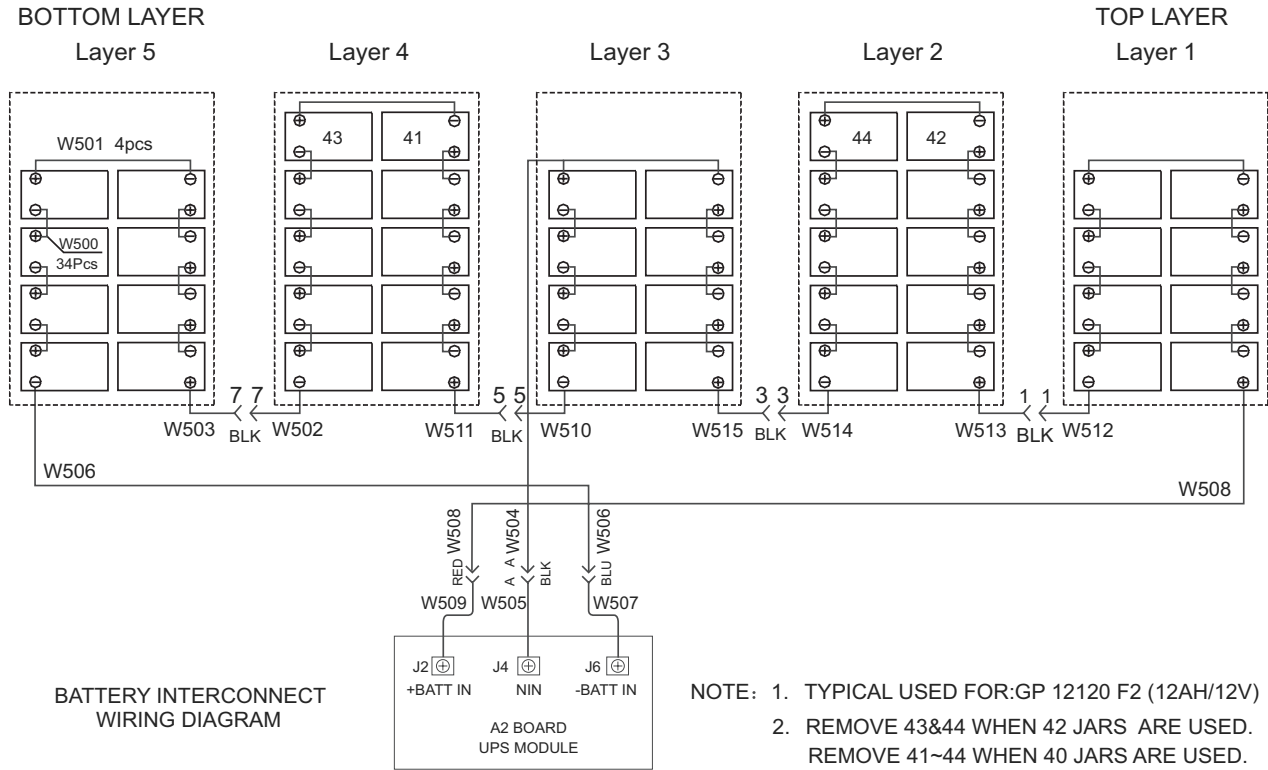

Figure 25 Internal battery layout and connecting—LC-R127R2PG1 (7.2AH/12V)

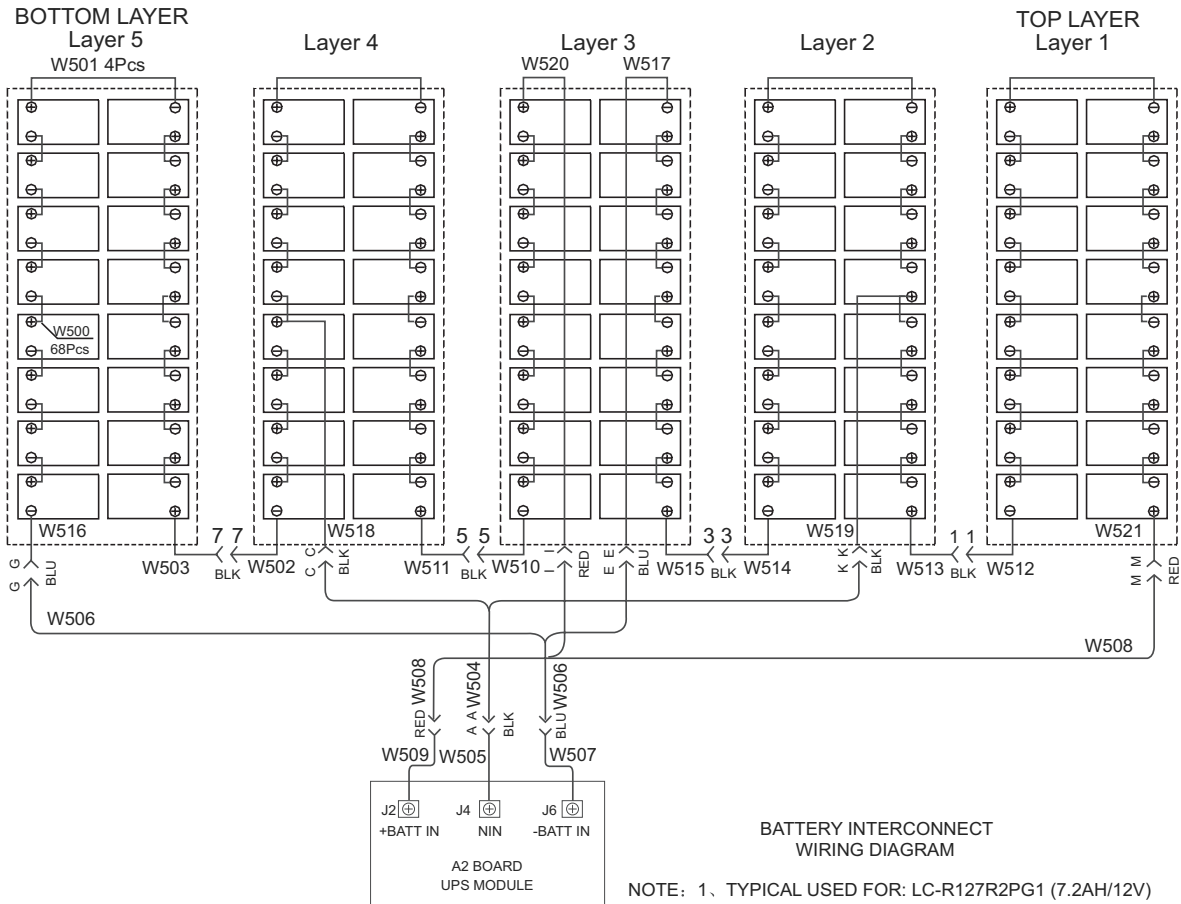
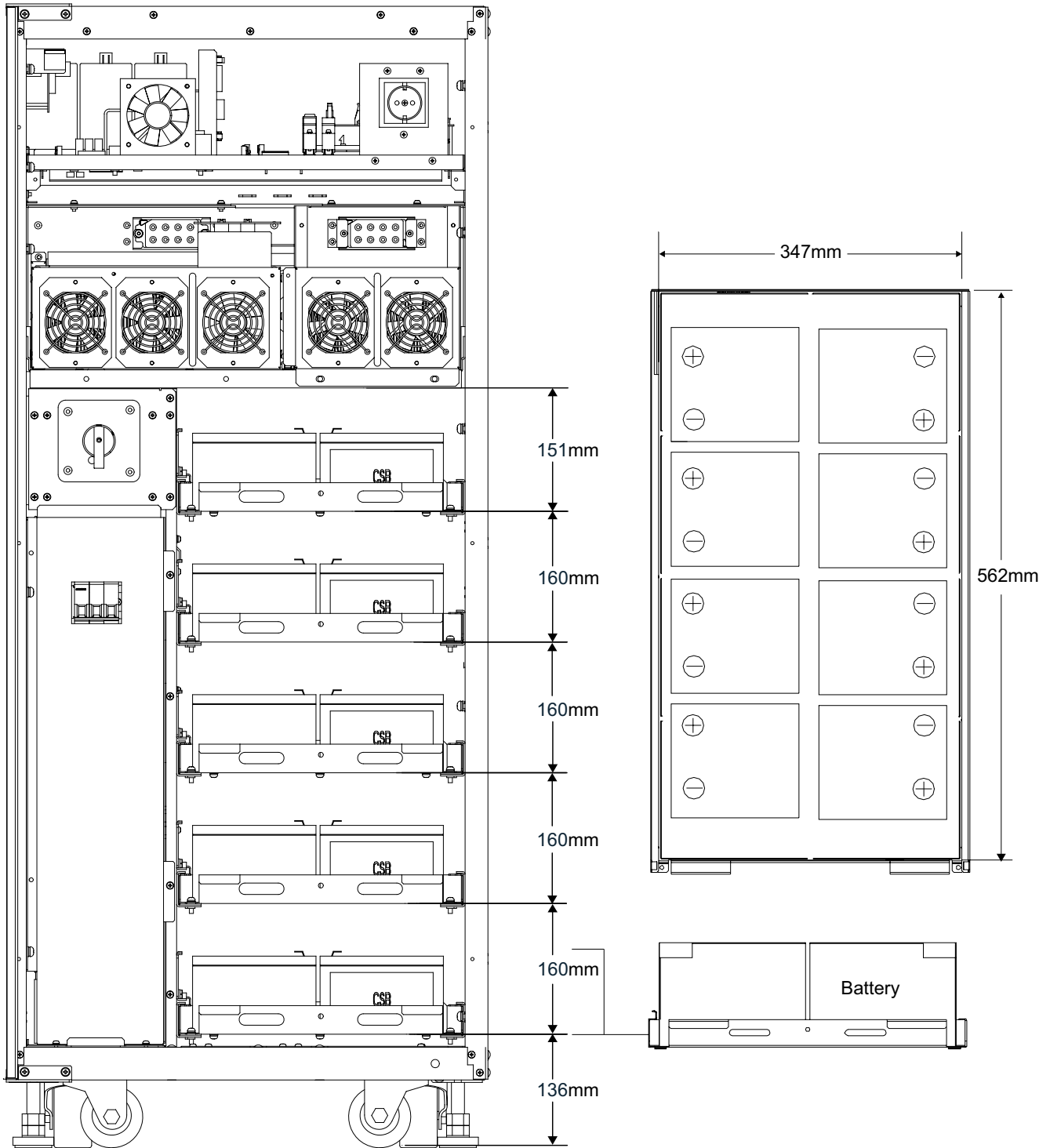

Figure 26 Internal battery layout



## 5.0 OPERATION



### WARNING

Hazardous Mains and / or Battery Voltage present behind covers.

No user-serviceable parts are located behind covers that require a tool for their removal. Only qualified service personnel are authorised to remove such covers.

### 5.1 Introduction

Liebert's NX™ Uninterruptible Power System system provides continuous, high-quality AC power to your business-critical equipment, such as telecommunications and data processing equipment. The NX UPS supplies power that is free of the disturbances and variations in voltage and frequency common to utility power, which is subject to brownouts, blackouts, surges and sags.

The NX utilizes the latest in high frequency, double-conversion pulse width modulation (PWM) technology and fully digital controls to enhance its reliability and increase the ease of use.

The standard NX consists of the UPS and internal batteries in a compact, single cabinet.

As shown in **Figure 27**, the AC utility source is input at CB1 and the rectifier converts the AC utility into DC power. The inverter converts that DC power from the utility—or DC power from the batteries—into AC power for the load. The batteries power the load through the inverter in the event of a power failure. The utility source can also power the load through the static bypass.

If maintenance or repair of the UPS is necessary, the load can be switched without interruption in service to the maintenance bypass.

**Figure 27** Single unit block diagram with split-bypass input

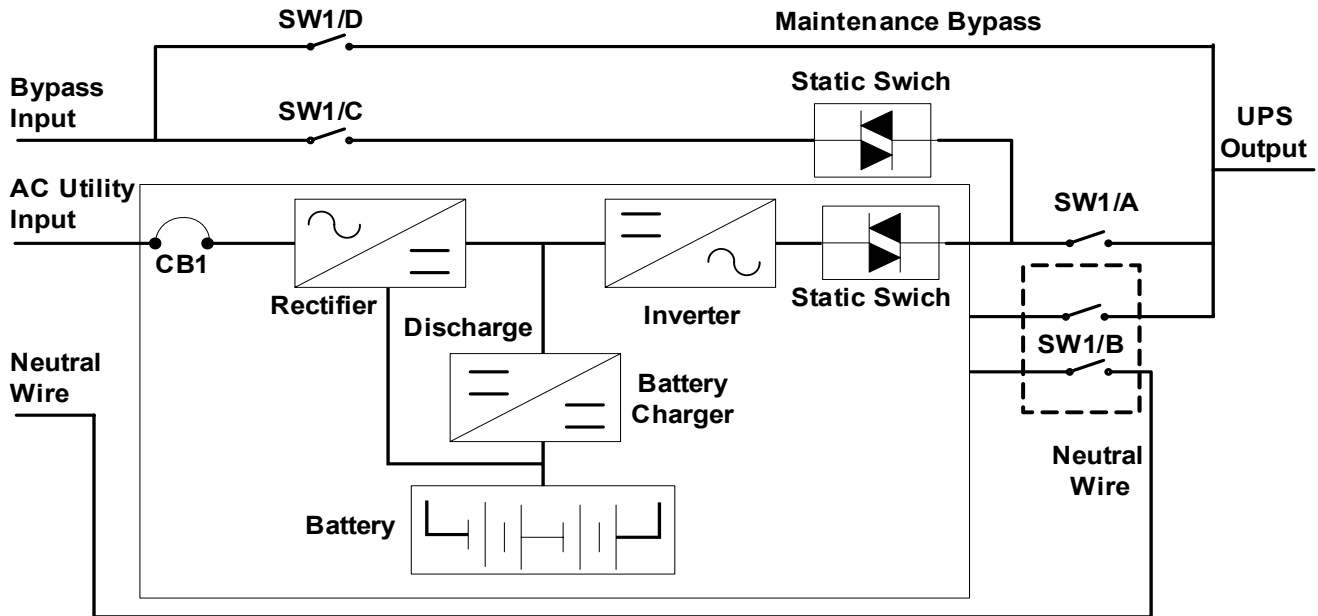

#### 5.1.1 Split-Bypass Input

**Figure 27** illustrates the Liebert NX UPS in what is known as the *split-bypass* configuration wherein a separate power switch to a dedicated bypass power source that also feeds the maintenance bypass line connects the static bypass line. Where a separate power source is not available, the bypass and rectifier input supply connections are linked.

### 5.1.2 Static Transfer Switch

The circuit blocks labeled *Static Switch* in **Figure 27** contain electronically controlled switching circuits that enable the critical load to be connected to either the inverter output or to a bypass power source via the static bypass line. During normal system operation the load is connected to the inverter; but in the event of a UPS overload or inverter failure, the load is automatically transferred to the static bypass line.

To provide a clean (no-break) load transfer between the inverter output and static bypass line, the static switch activates, connecting the load to bypass. To achieve this, the inverter output and bypass supply must be fully synchronized during normal operating conditions. This is achieved through the inverter control electronics, which make the inverter frequency track that of the static bypass supply, provided that the bypass remains within an acceptable frequency window.

A manually controlled, maintenance bypass supply is incorporated into the UPS design. It enables the critical load to be powered from the utility (bypass) supply while the UPS is shut down for routine maintenance.



**NOTE**

*When the UPS is operating in bypass mode or on maintenance bypass, the connected equipment is not protected from power failures or surges and sags.*

### 5.1.3 Battery Temperature Compensation

For 10-30kVA UPS with internal batteries, a standard temperature probe is installed to measure the internal battery temperature to optimize battery management. The measured temperature can be displayed from the UPS front panel.

For UPS with external batteries, an optional battery temperature interface equally optimises the external battery management by connecting up to four external temperature sensors from the battery cabinet(s) to a control unit inside the UPS.

**Figure 28 Multiple battery temperature sensors**

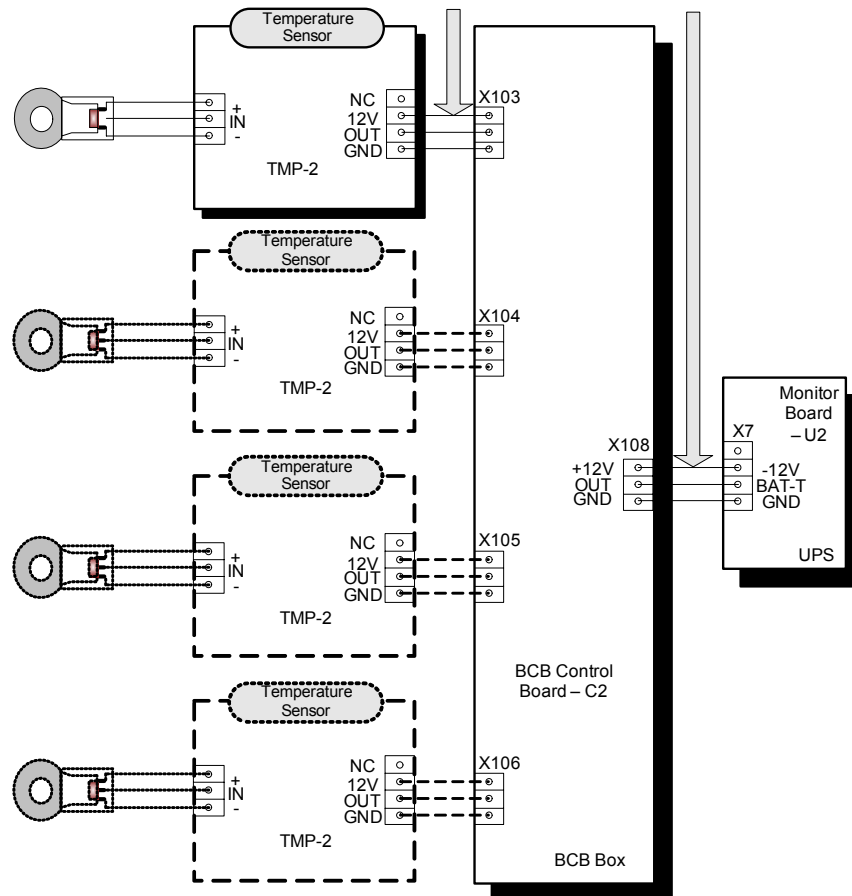



### 5.1.4 Redundant Control Power Supply Board

The UPS is equipped with two identical and fully redundant control power supply boards. Each of them takes inputs from the AC and DC sources. When one of the sources or even if one of the control power boards fails, the UPS system can still operate normally. This feature further enhances the reliability of the system.

### 5.1.5 Socket Outlet

One single-phase Shuko-type universal outlet of 3A current handling capability provides nominal UPS output voltage of up to 3A current capacity for the ease of testing, commissioning & servicing of the UPS.

## 5.2 Multi Module UPS—1+N

Multi-module UPS are formed by several “single unit” UPS modules to constitute “1+N” system where groups of one or more, up to six, single units operate together for the purpose of providing additional power or reliability or both. The load is equally shared between any paralleled UPS.

Figure 29 1+N multi-module UPS with external maintenance bypass switch

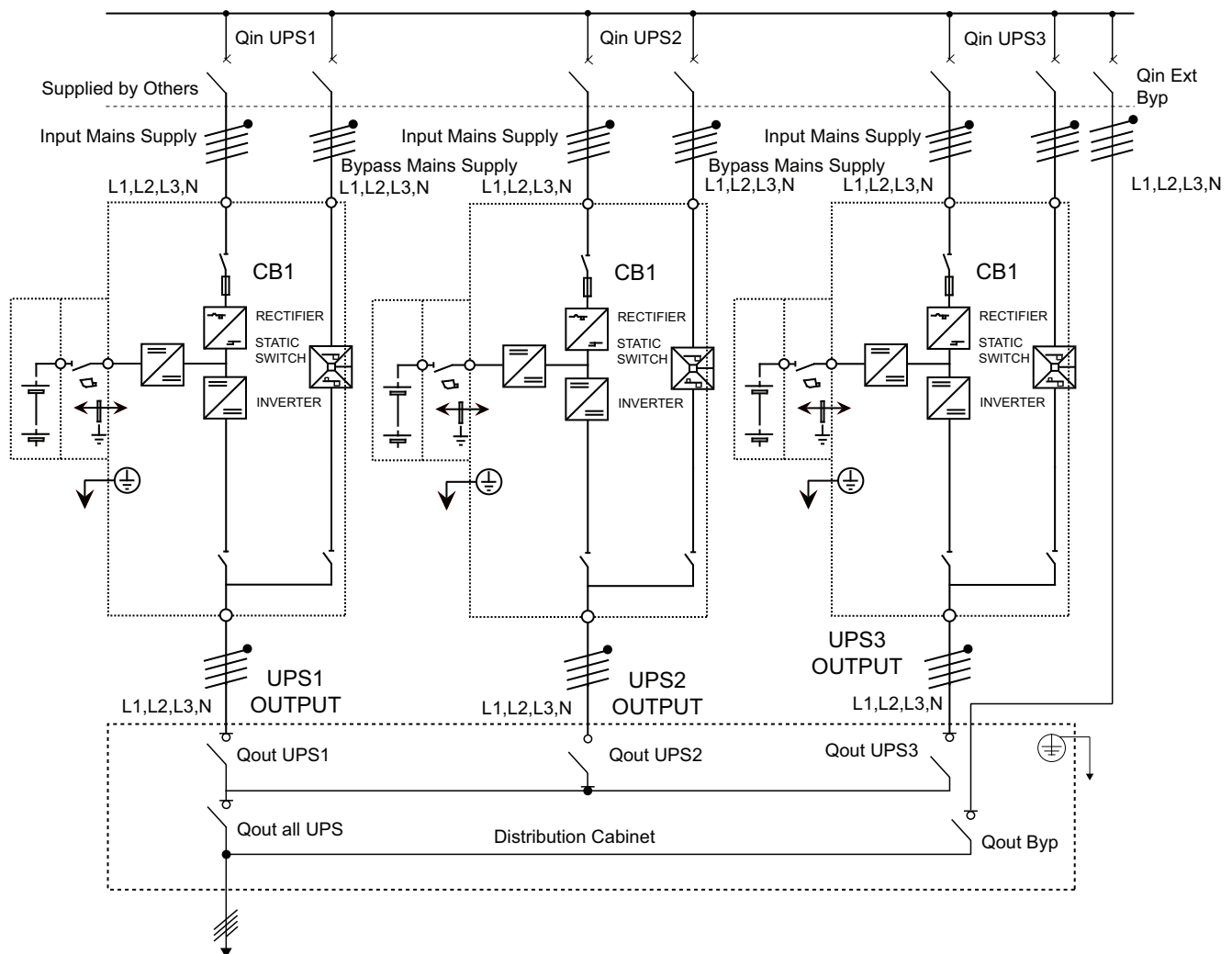

Further, single unit or 1+N groups may be configured as “distributed redundant” systems with independent outputs that nevertheless are synchronised through a Load Bus Synchroniser (LBS) so that critical loads can be seamlessly transferred from one system to another. See 5.3 - Modes of Operation for more information.

### 5.2.1 Features of NX Multi-Module UPS Configurations

1. The hardware and firmware of single module UPS units is completely compatible with the requirements of a multi-module system. Multi-module configuration is achieved merely through settings in configuration software.
2. Parallel control cables are connected in a ring, providing both performance and redundancy. Dual-bus control cables are connected between any two UPS modules of each bus. The intelligent paralleling logic provides the user with maximum flexibility. For example, shutting down or starting up UPS modules in a parallel system can be done in any sequence. Transfers between Normal and Bypass modes of operation are synchronised and self-recovering e.g. following overloads and their clearance.
3. The total load of the multi-module system can be queried from each module's LCD display.

### 5.2.2 Requirements for Paralleling of UPS Modules

A group of paralleled modules behave as if it were one large UPS with the advantage of presenting higher reliability. In order to assure that all modules are equally utilised and to comply with relevant wiring rules, the following requirements apply:

1. All UPS modules must be of the same rating and must be connected to the same bypass source.
2. The bypass and the main input sources must be referenced to the same neutral potential.
3. Any RCD, Residual Current monitoring device, if installed, must be of an appropriate setting and located upstream of the common neutral bonding point. Alternatively, the device must monitor the combined 4-wire rectifier and split-bypass input currents of the system. Refer to the **High Leakage Current Warning on page 1**.
4. The outputs of all UPS modules must be connected to a common output bus.



#### NOTE

*Optional isolation transformers are available for applications where sources do not share the same neutral reference or where the neutral is not available.*

## 5.3 Modes of Operation

The NX UPS is an on-line, double-conversion, reverse-transfer UPS that permits operation in these modes:

- Normal Mode
- Battery Mode (Stored Energy Mode)
- Auto-Restart Mode
- Bypass Mode
- Maintenance Mode (Manual Bypass)
- ECO Mode
- Parallel Redundancy Mode
- Hot-Standby Mode
- Frequency Converter Mode

### 5.3.1 Normal Mode

The UPS inverter continuously supplies the critical AC load. The rectifier/charger derives power from the AC mains input source and supplies DC power to the inverter while simultaneously FLOAT or BOOST charging its associated backup battery.

### 5.3.2 Battery Mode (Stored Energy Mode)

Upon failure of the AC mains input power; the inverter, which obtains power from the battery, supplies the critical AC load. There is no interruption in power to the critical load upon failure or restoration of the AC mains input power after which the "Normal Mode" operation will continue without the necessity of user intervention.

### 5.3.3 Auto-Restart Mode

The battery may become exhausted following an extended AC mains failure. The inverter shuts down when the battery reaches the End Of Discharge voltage (EOD). The UPS may be programmed to "Auto Recovery after EOD" after a delay time. This mode and any delay time are programmed by the commissioning engineer.

### 5.3.4 Bypass Mode

If the inverter overload capacity is exceeded, or if the inverter becomes unavailable for any reason, the static transfer switch will perform a transfer of the load from the inverter to the bypass source, with no interruption in power to the critical AC load. Should the inverter be asynchronous with the bypass, the static switch will perform a transfer of the load from the inverter to the bypass with interruption in power to critical AC load. This is to avoid paralleling of unsynchronised AC sources. This interruption is programmable but typically set to be less than 3/4 of an electrical cycle, e.g., less than 15ms (50Hz) or less than 12.5ms (60Hz).

### 5.3.5 Maintenance Mode (Manual Bypass)

A manual bypass switch is available to ensure continuity of supply to the critical load when the UPS becomes unavailable e.g. during a maintenance procedure. This manual bypass switch is fitted in all UPS modules and rated for full load of one module.

### 5.3.6 ECO Mode (Single UPS Only)

IF ECO mode is selected, the double-conversion UPS operation is inhibited at most times for the purpose of saving energy. In this mode of operation, not unlike UPS of line-interactive or stand-by technology, the bypass is the preferred source and only when the voltage and / or frequency of the bypass supply are beyond pre-defined and adjustable limits the critical AC load is transferred to the inverter. This transfer takes place with an interruption of less than 3/4 of an electrical cycle, e.g., less than 15ms (50Hz) or less than 12.5ms (60Hz).

### 5.3.7 Parallel Redundancy Mode (System Expansion)

For higher capacity or higher reliability or both, the outputs of up to six UPS modules can be programmed for directly paralleling while a built-in parallel controller in each UPS ensures automatic load sharing.

### 5.3.8 Hot-Standby Mode

This is an alternative 1+1 redundancy application that ensures higher availability or better usage control or both. Two UPS are connected in Hot Stand By mode as follows: UPS 1 connects to the critical load, and UPS 2 connects to the bypass of UPS 1. The remaining AC inputs are connected to the incoming AC mains supply. UPS 1 synchronises to the output of the UPS 2 ensuring uninterrupted load transfer from UPS 1 to UPS 2 or vice versa. This ensures that any specified load is supplied by a UPS while still providing a bypass path to cater for overloads. Further, the system can also be programmed to reverse UPS1 between Normal and Bypass Modes so that each UPS is equally utilised. This interval is programmable from 1 to 4,320 hours (180 days).

### 5.3.9 Frequency Converter Mode

The NX UPS can be programmed into frequency converter mode for either 50Hz or 60Hz stable output frequency. The input frequency may vary from 40Hz to 70Hz. In this mode the static bypass operation is disabled, and the battery becomes optional depending on any requirement to operate in battery mode (stored energy mode).

## 5.4 Battery Management—Set During Commissioning

### 5.4.1 Normal Function

- **Constant charging current**—Current can be set up to limit charging power.
- **Constant boost voltage boost** (if applicable)—Voltage of boost charging can be set as required by the type of battery.  
For Valve Regulated Lead Acid (VRLA) batteries, maximum boost charge voltage should not exceed 2.4V / cell.
- **Float Charge**—Voltage of float charging can be set as required by the type of battery.  
For VRLA, float charge voltage should be between 2.2V to 2.3V.
- **Float Charge Temperature Compensation** (optional)—A coefficient of temperature compensation can be as required by the type of battery.
- **End of discharge protection (EOD)**—If the battery voltage is lower than the EOD, the battery converter will shut down and the battery is isolated to avoid further battery discharge. EOD is settable from 1.6V to 1.75V per cell (VRLA) or 0.9 to 1.1 V per cell (NiCd).
- **Battery Low Warning Time**—Settable between 3 and 60 minutes. The default is 5 minutes.

### 5.4.2 Advanced Functions (Software Settings Performed by the Commissioning Engineer)

#### Battery Self-Test and Self-Service

At periodic intervals 20% of the rated capacity of the battery will be discharged automatically. The minimum amount of load must exceed 20% of the nominal rating of the UPS module. If the load is less than 20%, auto-discharge cannot be executed. The periodic interval can be set from 30 to 360 days. The periodic testing can also be inhibited.

- **Conditions**—Battery float charge for at least 5 hours, load 20~100% of rated UPS capacity
- **Trigger**—Manually through through the command of Battery Maintenance Test in the LCD panel or automatically
- **Battery Self-Test Interval**—30-360 days (default setting is 60 days)

## 5.5 Battery Protection (settings by commissioning engineer)

### Battery Undervoltage Pre-warning

The battery undervoltage pre-warning occurs before the end of discharge. After this pre-warning, the battery should have the capacity for 3 remaining minutes discharging with full load. The time is user configured from 3 to 60 minutes.

### Battery End of Discharging (EOD) Protection

If the battery voltage is lower than the EOD, the battery converter will be shut down. EOD is settable from 1.6V to 1.75V per VRLA cell (or 1.0 to 1.1V per NiCd cell).

### Battery Isolator Open Warning

If the battery isolator is open, this warning will occur.

The external battery to the UPS through an external battery isolator, which is manually closed and electronically tripped via the UPS control circuits.

## 6.0 OPERATING PROCEDURES



### WARNING

Hazardous mains and / or battery voltage present behind covers.

No user-serviceable parts are located behind covers that require a tool for their removal. Only qualified service personnel are authorised to remove such covers.

### 6.1 Introduction

The NX can operate in any of four modes, as shown in **Table 9**. This section provides instructions on switching between modes, resetting the UPS, switching the inverter On and Off and performing other operations.

**Table 9** UPS operating modes

Operating Mode	Rotary Switch Position	Description
Normal Operation	NORMAL	The UPS is powering the load.
On Static Bypass	BYPASS or NORMAL	The load power is supplied through the static bypass line. This may be considered as a temporary mode during load transfers between inverter and maintenance bypass or supply under abnormal operating conditions.
On Test	TEST	No load power is supplied by the UPS. The load is connected to utility power via the Maintenance Bypass Supply line. NOTE: The load is not protected against disturbances in AC input power in this mode.
On Maintenance Bypass	MAINT	The UPS is shut down but the load is connected to utility power via the Maintenance Bypass Supply line. NOTE: The load is not protected against disturbances in AC input power in this mode.



#### NOTE

1. The user controls and indicators mentioned in these procedures are identified in **7.0 - Operator Control Panel and Display**.
2. The audible alarm may sound at various points during these procedures. It can be canceled at any time by pressing the **SILENCE ON/OFF** push button.



#### NOTE

This unit refers to some modes and conditions that are set or adjusted using proprietary service software. To take advantage of all the available features for the NX, the unit must be commissioned by a Liebert factory-trained service engineer.

#### 6.1.1 Power Switches

The UPS unit power switches are CB1 and SW1.

- CB1-Input Current Breaker. Connects the utility supply to the UPS input.
- SW1 - Rotary switch. Has four positions—NORMAL, BYPASS, TEST and MAINT—that correspond to different positions of the SW1-A/B/C/D.

The positions of the rotary switch (SW1) are:

- SW1-A—Output Isolator. Connects the output of the UPS to the load.
- SW1-B—Neutral Isolator. Connects neutral to the UPS.
- SW1-C—Bypass Isolator. Connects the UPS with the bypass supply.
- SW1-D—Maintenance Bypass Isolator. Permits supply of the load directly by the bypass line for maintenance of the UPS unit.

The functions of the rotary switch are shown in **Table 10**.

**Table 10** Rotary switch configurations

Rotary Switch Position	OUTPUT (SW1-A)	BYPASS (SW1-C)	MAINT (SW1-D)	NEUTRAL (SW1-B)
NORMAL	✓	✓		✓
BYPASS	✓	✓		✓
TEST		✓	✓	✓
MAINT			✓	

## 6.2 UPS Startup

The NX must be fully installed and commissioned before startup, and external power isolators must be closed. Once those general conditions are met, the UPS may be started.

### 6.2.1 Start-Up Procedure

To start the UPS from a fully powered-down condition:

1. Open the UPS door to gain access to the main power switches.

#### **WARNING**

During this procedure the output terminals will become live.

If any load equipment is connected to the UPS output terminals, please check with the load user and ascertain whether it is safe to apply power to the load. If the load is not ready to receive power, then ensure that it is safely isolated from the UPS output terminals.

#### **CAUTION**

Do not operate the rotary switch too fast. Always wait at least 30 seconds when rotating the switch from one position to another

2. Close CB1.
3. Turn the rotary switch to TEST.

The bypass static SCR (M2) closes automatically and the LCD begins to show start-up screens. The rectifier indicator flashes green while the rectifier is starting up. It stops flashing and becomes solid green about 30 seconds after the rectifier enters the normal operation state. After initialization, the bypass static switch closes.

Because output switch SW1-A is still open, the UPS channels power through Maintenance Bypass Supply line (SW1-D). The bypass indicator extinguishes, provided that the bypass is normal.

The UPS mimic display indicators will be:

Indicator	State
Rectifier indicator	Off
Battery indicator	Off
Bypass indicator	Off
Inverter indicator	Off
Load indicator	Off
Status indicator	Off

#### **WARNING**

Do NOT turn the rotary switch until the rectifier indicator stops flashing green.

4. Turn the rotary switch to BYPASS.

Indicator	State
Rectifier indicator	Green
Battery indicator	Off
Bypass indicator	Green
Inverter indicator	Off
Load indicator	Green
Status indicator	Amber

The maintenance switch SW1-D opens and output switch SW1-A closes. The UPS powers from static bypass instead of from maintenance bypass. The bypass and load indicators turn on. The design of the rotary switch ensures uninterrupted output.

5. Turn the rotary switch to NORMAL, then press the INVERTER ON control button for 2 seconds. The inverter will start and the inverter indicator will flash green. After the inverter is ready, the UPS transfers from bypass to inverter, the bypass indicator turns off and the inverter and load indicators turn on.

The UPS is operating normally. The UPS mimic display indicators will:

Indicator	State
Rectifier indicator	Green
Battery indicator	Off
Bypass indicator	Off
Inverter indicator	Green
Output indicator	Green
Status indicator	Green

### 6.2.2 Verify Switching Between Operation Modes

Switch from normal mode to battery mode

- Open CB1 to enter battery mode. This breaks the utility connection to the NX.  
To return to normal mode, wait a few seconds and close CB1. The rectifier will restart automatically after 10 seconds and resume feeding power to the inverter.

Switch from Normal Mode to Bypass Mode

- Press INVERTER OFF button to switch to bypass mode.



**NOTE**

*In bypass mode, the load is being powered by the utility and is not receiving conditioned power through the inverter.*

Switch from Bypass Mode to Normal Mode

- Turn the rotary switch to NORMAL.
- In bypass mode, press the INVERTER ON button. When the inverter is ready, the UPS will switch to normal mode.

### 6.3 Switching the UPS from Normal to Maintenance Bypass

Follow the procedure below to transfer the load from the inverter output to the Maintenance Bypass line of the UPS.



#### CAUTION

Before performing this operation, read the messages on the LCD to be sure that bypass supply is regular and the inverter is synchronous with it. If those conditions are not present, there is a risk of a short interruption in powering the load.

This procedure assumes that UPS is operating normally.

1. Press the INVERTER OFF button on the right side of the operator control panel for longer than 2 seconds.

The Inverter indicator will turn off and the status indicator (6) will turn amber and an audible alarm will sound. The load will transfer to static bypass and the inverter will shut off.



#### NOTE

*Pressing the Alarm Silence Switch cancels the audible alarm, but leaves the warning message displayed until the appropriate condition is rectified.*

2. Open the UPS door to gain access to the main power switches, SW1 and CB1.
3. Turn the rotary switch to BYPASS position. The UPS Bypass Static Switch still supply power to load.
4. Turn the rotary switch to TEST. The load is now on maintenance bypass.
5. Turn the rotary switch to MAINT.
6. Open rectifier switch CB1. All operator indicators and messages will turn off as the utility driven internal power supplies decay. The unit will power down, but the load will continue to be supplied by the manual maintenance bypass.



#### WARNING

Wait 5 minutes for the internal DC busbar capacitors to discharge before attempting to remove the internal protective barriers.



#### WARNING

Even with the UPS rotary switch in maintenance bypass position portions of the unit are still energized. Service is to be performed by qualified personnel only.



#### CAUTION

The load equipment is not protected from normal supply aberrations when operating in the maintenance bypass mode.

### 6.4 Powering Down the UPS

To power down the UPS completely, follow the procedures in **6.3 - Switching the UPS from Normal to Maintenance Bypass**.

To completely isolate the UPS from the AC supplies, the main external power input isolator (both isolators, where separate supplies are provided for rectifier and bypass) should be opened (see **Figure 30**).



#### WARNING

To prevent injury to personnel, lockout or tagout the service supplies.



## 6.5 Powering Down the UPS and Maintaining Power to Load



**NOTE**

*An external Maintenance Bypass Cabinet must be installed before attempting to perform the following procedure*

If the UPS needs to be shut down completely while maintaining power to the load, follow these steps:

1. Perform **Steps 1 through 5 in 6.3 - Switching the UPS from Normal to Maintenance Bypass.**
2. Close the external maintenance bypass rotary switch to Maint position.



**WARNING**

On the primary input distribution panel, which is often located distant from the UPS area, a label should be posted advising service personnel that the UPS circuit is under maintenance.



**WARNING**

Wait 5 minutes for the internal DC busbar capacitors to discharge.

The UPS is now completely powered down.



**NOTE**

*The maintenance bypass power switch may be operated at any time while the UPS is powered down to connect the load to the maintenance bypass supply if required*

The procedure can be performed only after the installation has been completed (which includes the maintenance bypass cabinet), after the system has been placed in operation by authorized personnel. See **Figure 30** for more information.

**Figure 30 Example of configuration for single UPS with external maintenance bypass cabinet.**

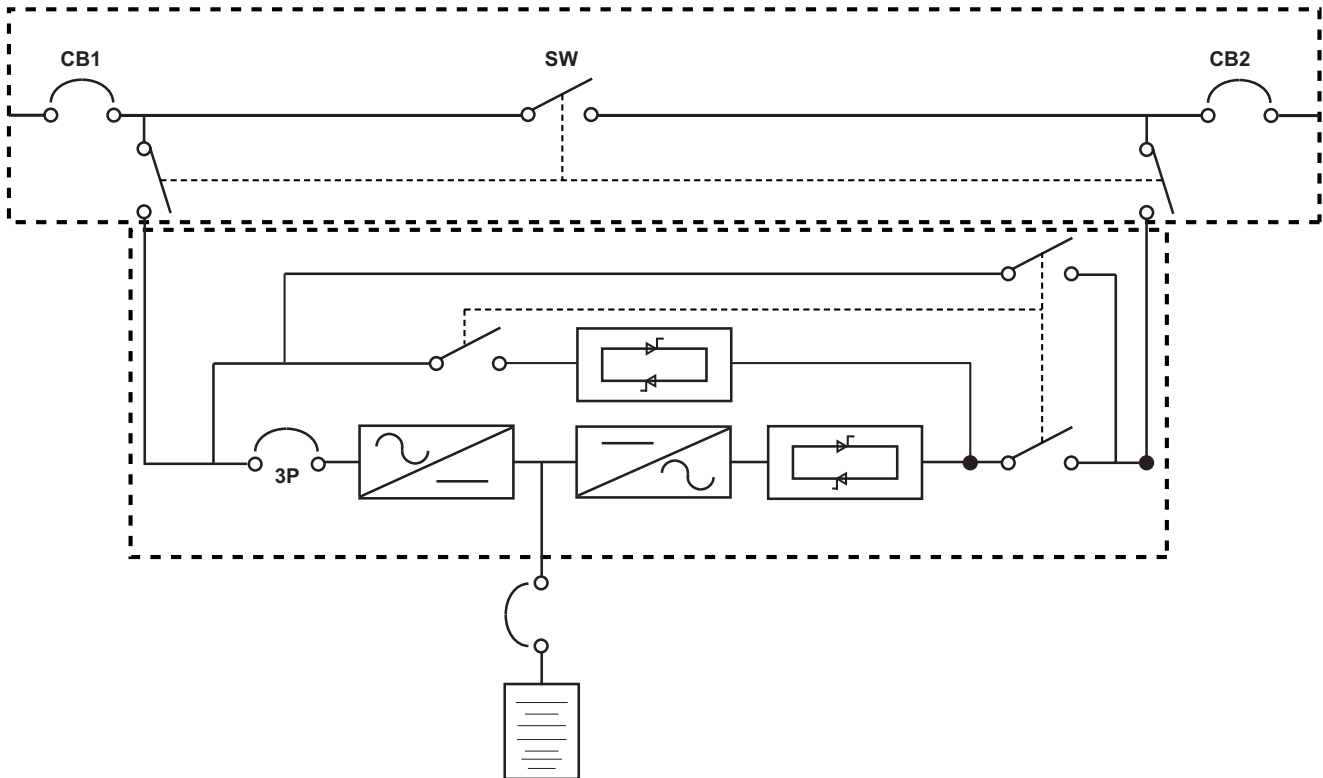

## 6.6 Emergency Shutdown With EPO

This circuit has been designed to switch off the UPS in emergency conditions (i.e., fire, flood, etc.). The system will turn off the rectifier, inverter and stop powering the load immediately (including the inverter and bypass), and the battery stops charging or discharging.

If the input utility is present, the UPS's controls will remain active; however, the output will be turned off. To remove all power from the UPS, the external feeder breaker should be opened.

## 6.7 Auto Restart

When the main and bypass sources fail, the UPS draws power from the battery system to supply the load until the batteries are depleted. When the UPS reaches its end of discharge (EOD) threshold, it will shut down.

The UPS will automatically restart and enable output power:

- After utility power is restored
- If "Auto Recovery after EOD Enabling" is enabled
- After the "Auto Recovery after EOD Delay Time" expires (the default delay is 10 minutes).

If the "Auto Recovery after EOD Enabling" feature is disabled, the user may restart the system manually by pressing "Fault Clear" button.

## 6.8 Reset After Shutdown for Emergency Stop (EPO Action) or Other Conditions

Once all appropriate measures have been taken to correct the problem indicated by the alarm message appearing on the operator control panel display, carry out this procedure to restore the UPS to regular operation following an EPO action or for the following reasons: Inverter Overtemperature, Cut-off Overload, Battery Overvoltage, excessive switching (BYP: XFER COUNT BLOCK), etc.

When the user confirms that the fault is cleared:

1. Press the FAULT CLEAR button to let the system exit the Emergency Off state.
2. Press the INVERTER ON button on the right side of the operator control panel for longer than 2 seconds.



### NOTE

*The rectifier will start again, and the bypass will begin to power the load (for units with internal battery contactor installed, the battery contactor will close). The Rectifier indicator flashes while the rectifier is starting up. When the rectifier enters the normal operation state (about 30 seconds), the rectifier indicator turns green.*



### NOTE

*The rectifier will be turned On automatically when the overtemperature fault disappears at 5 minutes after the disappearance of overtemperature signals.*

After the EPO button is pressed, if the input utility is removed, the UPS will shut down completely. When input utility is returned, if the rotary switch (SW1) is in either Bypass or in Normal position, the UPS will start up on Bypass. There will be power at the output terminals of the UPS.



## WARNING

If the rotary switch is in the Maint. position and input utility is present, there will be power at the output terminals of the UPS.

## 6.9 Language Selection

The LCD menus and data display are available in 12 languages: Chinese, Dutch, English, French, German, Italian, Japanese, Polish, Portuguese, Russian, Spanish and Swedish. To select a different language than the one being displayed:

1. From the main menu, press the F1 (shift) key to move the cursor to the menu at the top of the screen.
2. Press F2 and F3 (left and right arrows) as needed to select the Language menu.
3. Press F1 (shift) to move the cursor to the data and settings area of the LCD.
4. Use F2 and F3 (up and down) to select the required language.
5. Press the F4 (enter) key to accept the language selection.
6. Return to the main menu by repeatedly pressing F1 (ESC) as needed; all text on the LCD will now be displayed in the selected language.

## 6.10 Changing the Current Date and Time

To change the system date and time:

1. From the main menu, press the F1 (shift) key to move the cursor to the menu at the top of the screen.
2. Press F2 and F3 (left and right arrows) as needed to select the Settings menu.
3. Press F1 (shift) to move the cursor to the data and settings area of the LCD.
4. Use F2 and F3 (up and down) to select the Date & Time option, then press F4 (enter).
5. Position the cursor on the row in which the date and time are displayed, then press F4 (enter).
6. Using the F2 and F3 (up and down) keys, enter the current time and date information.
7. Press F4 (enter) to save the settings, then press F1 (ESC) to return to the main menu.

## 6.11 Command Password

Password protection is used to limit the control functions accessible to the operator. The default password is *12345*. This password provides access to UPS and battery test functions.

## 6.12 Isolating One Module in a Multi-Module System



### NOTE

*The Multi-Module system must have at least one UPS module redundant in the system and have an external output breaker installed with interlocking cables connected to the UPS module. The inverter firmware in each UPS in the system must be I140 or greater.*

1. With all UPS modules in the system in Normal mode, open the external output isolator.



### NOTE

*Opening the external output isolator under these conditions puts the UPS module into Standby mode. This is indicated by a flashing inverter LED and the message “Check UPS output.”*

*An “Inverter asynchronous” alarm is also normal. The remaining UPS modules will remain on line and “Parallel comm fail” will annunciate.*

2. Press the UPS EPO to isolate the batteries.
3. Open the UPS door to gain access to the main power switches SW1 and CB1.
4. Turn the rotary switch (SW1) to the Bypass position then continue to rotate to Test.



### NOTE

*With the UPS external output breaker open and auxiliary switches closed the UPS control will enable the UPS switch to be rotated through “Bypass” without initiating the remaining on line UPS modules to transfer to Bypass.*

5. Open rectifier input breaker CB1.



## WARNING

Hazardous Battery Voltage

No operator serviceable parts are located behind covers that require a tool for their removal.

Only qualified service personnel are authorised to remove such covers.

The UPS battery and connecting terminals remains energized at hazardous voltage levels at all times. The battery is located behind protective covers that require a tool for their removal: inside the UPS cabinet, inside a free-standing battery cabinet or on open racks inside a dedicated battery room that may be locked.

## 6.13 Inserting One Module into a Multi-Module System

This procedure is indicated to reintegrate a UPS module that has been previously isolated from other modules of a group of paralleled UPS modules. It is assumed that the installation is complete, the system has been commissioned by authorized personnel and the **external power isolators are open**.



### WARNING

Mains voltage will be applied to UPS output terminals.

No operator serviceable parts are located behind covers that require a tool for their removal.

Only qualified service personnel are authorised to remove such covers.

1. Open the UPS door to gain access to the main power switches.
2. Rotate the switch to Test position. The LCD display becomes active.
3. Close the Input breaker CB1  
The Rectifier indicator flashes on the UPS mimic panel during the startup of rectifier and becomes steady green once the rectifier reaches normal operation state after about 30s.
4. Close external battery circuit breaker QF1 (where an external battery is used). This breaker is located inside the battery cabinet (if used) or is otherwise adjacent to the battery racks
5. Following battery availability being detected by the UPS, the red battery indicator extinguishes moments after when the battery charger starts operation.
6. Rotate switch to Bypass position
7. Turn the rotary switch to NORMAL.
8. Close external output power isolators.
9. Press the INVERTER ON control button for 2 seconds.  
The inverter will startup and the inverter indicator will flash while it synchronizes to the load voltage and frequency. After the inverter is ready, the UPS connects to the load, the inverter indicator becomes steady green and the output indicator becomes green.
10. Check that no "Warning" message is displayed in the top right corner of the LCD Monitor and the status of the indicators as follows:

# LED	LED Function	Status
1	Rectifier indicator	green
2	Battery indicator	off
3	Bypass indicator	off
4	Inverter indicator	green
5	Output indicator	green
6	Alarm indicator	off

The UPS is now operating in NORMAL mode.

## 7.0 OPERATOR CONTROL PANEL AND DISPLAY

### 7.1 Introduction

The operator control panel and display is located on the front door of the UPS. The panel is the access point for operator control and monitoring of all measured parameters, UPS and battery status and of event and alarm logs.

**Figure 31 UPS control and display panel**

The operator control panel is divided into three functional areas

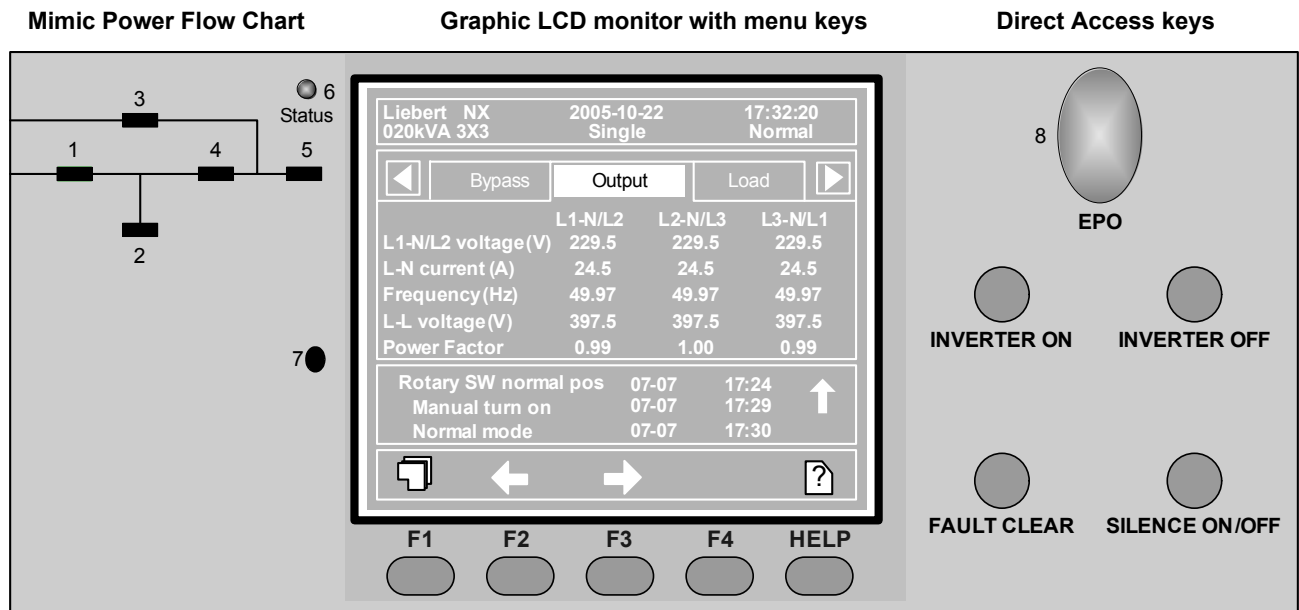

**Table 11 UPS control and display panel components**

Component #	Function
1	Rectifier (Input AC to DC)
2	Battery (DC Back-up)
3	Bypass Input
4	Inverter (DC to AC)
5	Load (AC Output)
6	UPS Status and Alarm indicator
7	Audible Alarm (Buzzer)_
8	Emergency Power Off Button cover

Button	Function
EPO	Emergency Power Off button
Inverter ON	Inverter start button
Inverter OFF	Inverter shutdown button
Fault Clear	Reset button
Silence On/Off	Audible Alarm Mute
—	—
F1-F4, Help	LCD Menu keys
—	—

### 7.1.1 Mimic Power Flow

The LEDs mounted on the mimic flow chart represent the various power paths and current UPS operational status.

**Table 12 Rectifier indicator—1**

<b>Green</b>	Rectifier in Normal Operation
<b>Flashing Green</b>	Input AC Normal, but rectifier not operating
<b>Red</b>	Rectifier Failed
<b>Off</b>	Rectifier Not operating, Input AC Not Available or out of normal range

**Table 13 Battery indicator—2**

<b>Green</b>	Battery Normal, but discharging and powering the load
<b>Flashing Green</b>	Battery End of Discharge pre-warning
<b>Red</b>	Battery abnormal (Failed, Absent or Polarity Reversed) or Battery Converter abnormal (Failed, overcurrent, overtemperature)
<b>Off</b>	Battery and Converter Normal, Battery charging.

**Table 14 Bypass indicator—3**

<b>Green</b>	Load on Bypass power
<b>Red</b>	Bypass not available, out of normal range or Static bypass switch fault.
<b>Off</b>	Bypass Normal, load not on bypass

**Table 15 Inverter indicator—4**

<b>Green</b>	Inverter Normal and powering the load
<b>Flashing Green</b>	Inverter ON, starting up, synchronising, or standing by (ECO mode)
<b>Red</b>	Inverter failed
<b>Off</b>	Inverter not operating

**Table 16 Load indicator—5**

<b>Green</b>	UPS output ON and Normal
<b>Red</b>	UPS output ON and Overloaded
<b>Off</b>	UPS output OFF.

**Table 17 Status (Alarm) indicator—6**

<b>Green</b>	Normal Operation
<b>Yellow</b>	UPS Warning e.g. AC Input Failure
<b>Red</b>	UPS fault e.g. Fuse or Hardware failure

### 7.1.2 Audible Alarm (Buzzer)

UPS activity is accompanied by the following sounds

**Table 18 Audible alarm key**

<b>Single beep</b>	Direct Access key acknowledgement
<b>One beep per second</b>	UPS Warning e.g. AC Input Failure
<b>Continuous beep</b>	Fault e.g. Fuse or Hardware failure

### 7.1.3 Direct Access Push Buttons (Keys)

<b>Emergency Power Off (EPO)</b>	Disconnects Power to the Load. Disables rectifier, inverter, static bypass and battery operation.
<b>Inverter ON</b>	Enables Inverter Operation
<b>Inverter OFF</b>	Disables Inverter Operation
<b>Fault clear</b>	Resets blocked UPS functions (subject to any fault being cleared)
<b>Silence ON/OFF</b>	Toggle type buzzer mute. Any new fault re-enables the buzzer.

Press and hold Direct Access key briefly until acknowledged by a single beep.



### 7.1.4 LCD Monitor and Menu keys

The user-friendly and menu-driven 320 x 240 dot graphic LCD monitor displays real time data and at the same time stores 512 historical records that can retrieve for reference and diagnosis.

The user can perform commands or easily browse through the input, output, load and battery parameters. For quick reference, the UPS status and any warnings are always highlighted without the need of navigating through the menu. The versions of converter firmware, inverter firmware and internal monitor firmware can also be displayed on the LCD.

Menu keys F1 to F4 are used to navigate within the graphic LCD monitor windows.

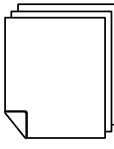
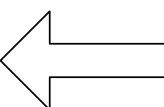
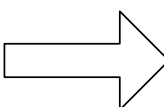
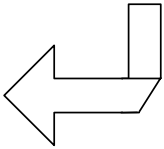
**Table 19 Menu key Icons and their meaning**

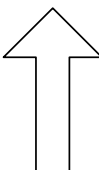
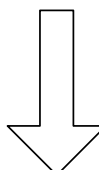
Key	F1	F2	F3	F4	Help
Window Type 1	 Next Data Window	 LEFT	 RIGHT	 ENTER	 HELP
Window Type 2	<b>ESC</b> Escape	 UP	 DOWN		

**Figure 32 Graphic LCD monitor windows and keypad**

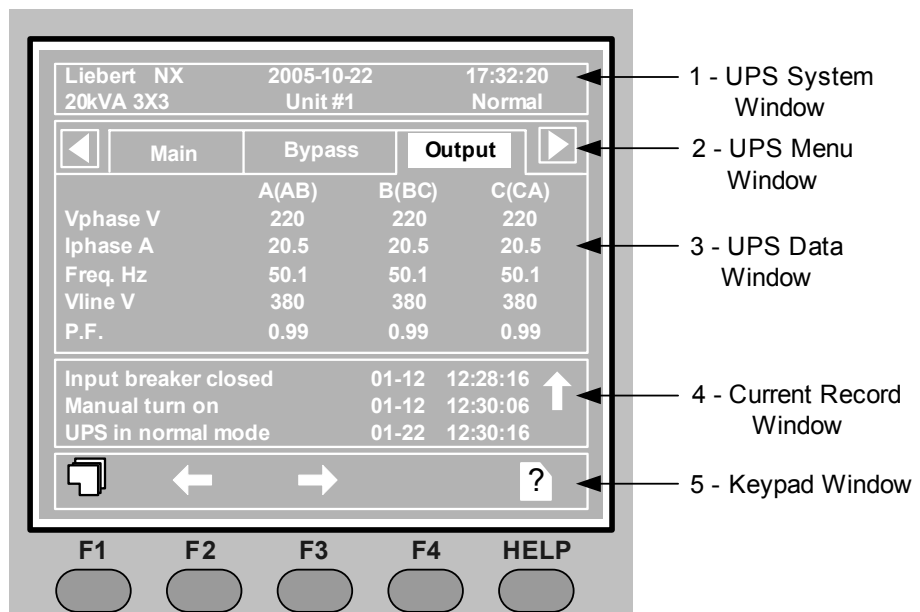



The function of keys F1 to F4 is shown by a self-explanatory icon as appropriate for the particular window. As shown in **Figure 32** above, pressing F1 moves the cursor (resting in “OUTPUT”) from the *UPS Menu Window (2)* to *current record window (4)* where it would first rest in “Input breaker closed”. In a similar manner, pressing F2 would move the cursor from the Output data window to the Bypass data window.

The summary menu tree is shown below. Refer to **7.2 - All Status and Event Messages Displayed on the UPS Front Panel** for a detailed description of each menu item.

**Figure 33 Menu tree**

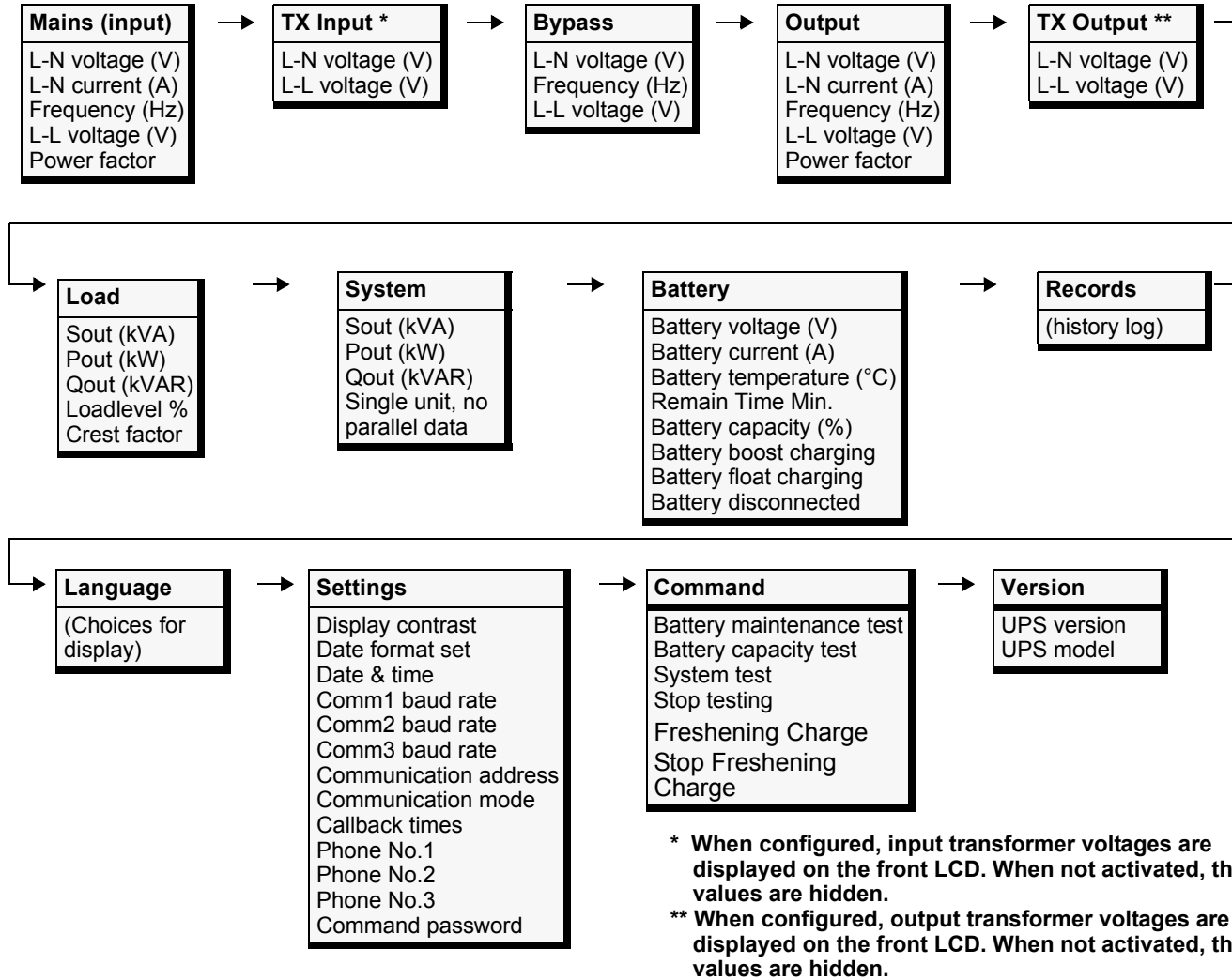

### 7.1.5 Detailed Description of Menu Items

The description that follows refers to the graphic LCD monitor window shown on **Figure 32**.

UPS System Window: This fixed-pane window displays current time and date and identifies the UPS, its configuration and its status.

**Table 20 UPS system window**

Description	Explanation
Liebert NX	UPS family name
2005-10-22	YYYY-MM-DD (see Settings menu for other date formats)
12:30:36	Current Time (24 hr HH:MM:SS format)
30kVA-3x3	30kVA = UPS rated output, 3 x 3 = 3-phase input and output
(Configuration) Single, ECO, Master, Slave or Unit # 1	Single = single double-conversion unit ECO = single stand-by unit with double-conversion fall-back Master = master in a 1+1 Hot Stand By system Slave = slave in a 1+1 Hot Stand By system Unit # 1 = of max 6 double-conversion units in a parallel system
(Status) Normal, Warning or Fault	Normal = UPS operating Normal Warning = System attention required, e.g. AC Input Failure Fault = UPS Fuse or Hardware Failure

#### Menu and Data Window

Use the horizontal arrow keys to navigate between any of the selectable menu and data windows.

**Table 21 Descriptions of UPS menus and data window items**

Menu Type	Item Type	Explanation
Mains (input)	L-N voltage (V)	Phase voltage
	L-N current (A)	Phase current
	Frequency (Hz)	Input frequency
	L-L voltage (v)	Line-line voltage
	Power factor	Power factor
TX Input	L-N voltage (V)	Phase voltage
	L-L voltage (V)	Line-line voltage
Bypass	L-N voltage (V)	Phase voltage
	Frequency (Hz)	Bypass frequency
	L-L voltage (A)	Line-line voltage
Output	L-N voltage (V)	Phase voltage
	L-N current (A)	Phase current
	Frequency (Hz)	Input frequency
	L-L voltage (V)	Line-line voltage
	Power factor	Power factor
TX Output	L-N voltage (V)	Phase voltage
	L-L voltage (V)	Line-line voltage
Load	Sout (kVA)	Sout: Apparent power
	Pout (kW)	Pout: Active power
	Qout (kVAR)	Qout: Reactive power
	Loadlevel %	The percent of the UPS rating load
	Crest factor	Output current Crest Factor

**Table 21 Descriptions of UPS menus and data window items (continued)**

Menu Type	Item Type	Explanation
System	Sout (kVA)	Sout: Apparent power
	Pout (kW)	Pout: Active power
	Qout (kVAR)	Qout: Reactive power
	Single unit, no parallel data	When configured as a single unit, UPS has only native load, no system load.
Battery	Battery voltage (V)	Battery bus voltage
	Battery current (A)	Battery bus current
	Battery temperature (°C)	Internal battery temperature °C
	Remain Time Min.	Battery run time remaining
	Battery boost charging	Battery is boost charging
	Battery float charging	Battery is float charging
	Battery disconnected	Battery is not connected
Records	(history log)	Displays all records in the history log
Language	(choices for text displayed)	User may select any of 12 languages for LCD text.
Settings	Display contrast	Adjust the LCD display contrast
	Date format set	Choose the format for date display: M/D/Y, D/M/Y, M/D/Y, Y/M/D
	Date & time	Set the date and time
	Comm1 baud rate	Communication baud rate setting for Intellislot 1
	Comm2 baud rate	Communication baud rate setting for Intellislot 2
	Comm3 baud rate	Communication baud rate setting for Intellislot 3
	Communication address	This setting is applicable to RS485 communication mode
	Communication mode	Communication Mode Setting
	Callback times	When Intellislot 1 Communication mode is Modem, this parameter sets the number of times a number is redialed to send an alarm notification.
	Phone No.1	When Intellislot 1 Communication mode is Modem, this is the first phone number to be dialed (to send an alarm notification).
	Phone No.2	When Intellislot 1 Communication mode is Modem, this is the second phone number to be dialed (to send an alarm notification).
	Phone No.3	When Intellislot 1 Communication mode is Modem, this is the third phone number to be dialed (to send an alarm notification).
	Command password	User can modify the command password.
Command (start/stop battery & system tests)	Battery maintenance test	This test performs a partial discharge of the battery to obtain a rough estimate of the battery capacity. Load must be between 20% and 100%.
	Battery capacity test	This test performs a full discharge of the battery to obtain a precise measure of the battery capacity. Load must be between 20% and 100%.
	System test	This is a self-test of the UPS. When the user activates this function, a pop-up window appears about 5 seconds later to show the results.
	Stop testing	Manually stops a battery maintenance test, battery capacity test or system test.
	Freshening Charge	This command will allow a temporary Equalize charge for the batteries. This charge is configurable for 1 to 36 hours
	Stop Freshening Charge	Manually stop a Freshening Charge
Version	UPS version	Provides UPS firmware version numbers for the inverter, rectifier and software display board.
	UPS model	Provides UPS model information—for example, 400V-50Hz.

### Current Record Window

Keeps a log the events that resulted in the current mode of operation. Ignores transient conditions that have been resolved.

Use “page” (F1) and up / down arrow to read the events.

For a complete history log, refer to the Records tab of the Menu and Data Window.

Refer to **Table 22** for a complete list of supported status messages.

## 7.2 All Status and Event Messages Displayed on the UPS Front Panel

This is the complete list of UPS events and status messages supported for display in either the Record window (Historic data) or in the Current window (Prevailing data) as described in **7.1.4 - LCD Monitor and Menu keys**.

**Table 22 UPS messages**

Message	Description / Suggested Action (if any)
Inverter Comm. Fail	Internal RS485 communication failure between monitor and inverter
Rectifier Comm. Fail	Internal RS485 communication failure between monitor and rectifier
Parallel Comm. Fail	The CAN communication between different UPSs within a parallel system fails. 1. Check if there are some UPSs not powered on in the parallel system. If so, power on these UPSs and check if the alarm disappears. 2. Press Fault Clear push button.
Battery Overtemp.	The Battery temperature is over limit. Check the battery temperature and ventilation
Ambient Overtemp.	The Ambient temperature is over limit. Check the ventilation of UPS room.
Battery Fault	Battery detected faulty ( <b>Reserved</b> )
Replace Battery	Battery test failed, Battery should be replaced.
Battery Low Pre-warning	Before the end of discharge, battery undervoltage pre-warning should occur. After this pre-warning, battery should have the capacity for 3 minutes discharging with full load. The time is user-configured from 3 to 60 minutes. Shut down the load in time.
Battery End of Discharge	Inverter turned off due to low battery voltage. Check the utility failure and try to recover it.
Mains Volt. Abnormal	Mains Voltage exceeds the upper or lower limit and results in rectifier shutdown. Check the input line-to-neutral voltage amplitude of rectifier.
Mains Undervoltage	Mains Voltage is undervoltage with derated load. Check the input line-to-line voltage amplitude of rectifier
Mains Freq. Abnormal	Mains frequency is out of limit range and results in rectifier shutdown. Check the rectifier's input voltage frequency
Rectifier Fault	Rectifier detected faulty. Rectifier shuts down. Battery discharges.
Rectifier Overtemp.	The temperature of heat sink is too high to keep the rectifier running. The UPS can recover automatically. Check the environment and ventilation.
Batt. Contactor Fail	Battery contactor or circuit breaker not responding to control signals.
Batt. Charger Fault	The voltage of the battery charger is too high.
Control Power 1 Fail	UPS operates but Redundant Control Power is not available.
Mains Phase Reversed	AC Input phase sequence is reversed.
Rectifier Overcurrent	Rectifier is overloaded.
Soft Start Fail	Rectifier could not start due to low DC bus voltage
Bypass Unable to Trace	This alarm is triggered by an inverter software routine when the amplitude or frequency of bypass voltage is beyond the normal range. The amplitude threshold is fixed for positive and negative 10% rating. This alarm automatically resets once the bypass voltage goes normal. 1. First verify that the bypass voltage and frequency displayed on the panel is within the selected range. Note here the rated voltage and frequency are specified by “Output voltage level” and “Output frequency level” respectively. 2. If the displayed voltage is believed to be abnormal, then verify the bypass voltage and frequency presented to the UPS. Check the external supply if it is found to be faulty.

Table 22 UPS messages (continued)

Message	Description / Suggested Action (if any)
Bypass Abnormal	<p>This alarm is triggered by an inverter software routine when the amplitude or frequency of bypass voltage exceeds the limit. This alarm automatically resets once the bypass voltage goes normal. First check if there are some relevant alarms such as "Bypass disconnect open", "Bypass phase reverse" and "Mains neutral lost". If they appear, solve them first.</p> <ol style="list-style-type: none"> <li>1. Then verify that the bypass voltage and frequency displayed on the panel is within the bypass limit. Note here the rated voltage and frequency are specified by "Output voltage level" and "Output frequency level" respectively.</li> <li>2. If the displayed voltage is believed to be abnormal, then verify the bypass voltage and frequency presented to the UPS. Check the external bypass supply if it is found to be faulty. If the utility is likely to trigger this alarm frequently, the bypass limit can be changed a little larger through the configuration software according to the customer's agreement.</li> </ol>
Inverter Asynchronous	<p>This alarm is triggered by an inverter software routine when the inverter and bypass waveforms are misaligned by more than 6 degrees in phase. This alarm resets automatically once the condition is no longer true.</p> <ol style="list-style-type: none"> <li>1. First check if the alarm "Bypass unable to trace" or "Bypass abnormal" occurs. If so, solve it first.</li> <li>2. Verify the waveform of the bypass voltage. If it is too distorted, ask the customer to verify and seek any possible measurements.</li> </ol>
Inverter Fault	Inverter output voltage beyond limits. Load transfers to bypass.
Inverter Overtemp.	<p>The temperature of the inverter heat sink is too high to keep inverter running. This alarm is triggered by the signal from a temperature monitoring thermostat on the inverter bridge heat sink. The UPS will recover automatically after a 5 minute delay from the disappearance of the overtemperature signal. If the overtemperature condition is true, then check for and verify:</p> <ol style="list-style-type: none"> <li>1. high ambient air temperature.</li> <li>2. blocked cooling airway.</li> <li>3. any fan failure.</li> <li>4. prolonged inverter overload</li> </ol>
Fan Fault	At least one of the cooling fans has failed
Inverter STS Fail	At least one of the static switches of inverter side is open or short circuit. This fault is locked until power off.
Bypass STS Fail	At least one of the static switches of bypass side is open or short circuit. This fault is locked until power off
Operation Invalid	This record is registered following an incorrect operation:
Output Fuse Fail	At least one of the inverter output fuses is blown. Inverter shuts down. Load transfers to bypass.
Control Power 2 Fail	UPS operates but Redundant Control Power is not available.
Unit Over load	<p>The UPS is confirmed to be overload when the load arises above 105% nominal rating. The alarm automatically resets once the overload condition is removed.</p> <ol style="list-style-type: none"> <li>1. Confirm that the alarm is true by checking the load percent indicated on the LCD panel to determine which phase is being overloaded.</li> <li>2. If the alarm is true, measure the actual output current to verify that the indications are valid. Disconnect unnecessary load and ensure the safety. In a parallel system, a severe load sharing error can also leads to the alarm.</li> </ol>
System Over load	<p>The UPS parallel system is confirmed to overload when the total load arises above 105% nominal rating for the set basic number of UPSs. The alarm automatically resets once the overload condition is removed.</p> <ol style="list-style-type: none"> <li>1. Confirm that the alarm is true by checking the system load percent indicated on the LCD panel to determine which phase is being overloaded.</li> <li>2. If the alarm is true, measure the actual output current to verify that the indications are valid. Disconnect unnecessary load and ensure the safety. In a parallel system, a severe load sharing error can also leads to the alarm.</li> </ol>

Table 22 UPS messages (continued)

Message	Description / Suggested Action (if any)
Unit Over load Timeout	The UPS is confirmed to overload and the overload times out. Note 1: the highest loaded phase will indicate overload timing-out first. Note 2: When the timer is active then alarm "unit overload" should also be active as the load is above nominal. Note 3: When the timer has expired, the inverter Static Switch is opened and the load transferred to bypass. The inverter shutdown and will restart after 10 seconds. Note 4: If the load decreases lower than 95% after 5 minutes, the system will transfer back to inverter mode. Confirm that the alarm is genuine by checking the load percent indicated on the LCD. If an overload is indicated then check the load, and investigate any additional load connected prior to the alarm (if applicable).
By. Abnormal Shutdown	Both bypass and inverter voltages unavailable. Load interruption
Inverter Over Current	Inverter Pulse Width Modulation module overloaded.
Bypass Phase Reversed	The phase sequence direction of bypass voltage is reversed. Normally, the phase of phase B lags 120 degrees behind phase A, and the phase of phase C lags 120 degrees behind phase B. Verify that the phase rotation of the bypass supply presented to the UPS is correct, and rectify it if it is found to be in error
Load Impact Transfer	A transfer to bypass occurred due to a large step load. The UPS should recover automatically. Turn on connected equipment in sequential order to reduce the step loading of the inverter.
Transfer Time-out	The load is on bypass power due to excessive number of transfers that occurred within the last hour. The UPS will recover automatically and will transfer the load back to inverter power within an hour.
Load Sharing Fault	UPS modules within a parallel system are not sharing the load current equally.
DC Bus Abnormal	DC input voltage to inverter beyond limits. Inverter shuts down. Load transfers to bypass.
System Transfer	The whole paralleled UPS system transferred to bypass at the same time. This message will appear on the UPS which passive transfer to bypass
Parallel Board Fault	Malfunction of the paralleling control circuits of this UPS module. Can cause "System Transfer" to bypass.
DC Bus Over Voltage	Rectifier, inverter and battery converter were shutdown because DC bus voltage is too high. Check whether there is a fault in rectifier side. If no, then check whether overload occurs. Restart the inverter after resetting the fault
Parallel Connect Fault	The parallel cables are not connected correctly in a parallel system. Reset the fault by pressing the "fault clear" button, then restart the inverter by pressing the "inverter on" button.
Bypass Over Current	Bypass current is over limit above 135% rating. The UPS just alarms and does nothing.
LBS Active	Load Bus Synchronisation is active. The UPS is acting as an LBS master or slave in a dual bus configuration.
Setting Save Error	History records not saved. <b>(Reserved)</b>
Mains Neutral Lost	AC Input mains reference neutral not detected.
Protocol version clash	Firmware incompatibility between Monitor Board and Digital Signal Processor Board.
Battery ground fault	Battery leakage to ground detected (option)
Inv. Turned On Manually	Manual Turn On via front panel
Inv. Turned Off Manually	Manual Turn Off via front panel
EPO	Emergency Power Off direct access key pressed or external command received
Transfer Confirm	Prompt to press "enter" key to acknowledge that an interrupted load transfer to bypass will happen.
Transfer Cancel	Prompt to press "ESC" key to avoid that an interrupted load transfer to bypass will happen.
Unit Off Confirm	Prompt to press "enter" key to acknowledge that the UPS will be disconnected from other paralleled UPS modules.
System Off Confirm	Prompt to press "enter" key to acknowledge that the all paralleled UPS will be disconnected from the load.

**Table 22 UPS messages (continued)**

Message	Description / Suggested Action (if any)
Fault Reset	Fault clear direct access key pressed
Alarm Silence	Silence On/Off direct access key pressed
Turn On Fail	Inverter failed to turn on when Inverter On direct access key was pressed. This may be as a result of Invalid Operation (Maintenance bypass on) or DC bus or rectifier not ready.
Alarm Reset	Fault clear or Silence On/Off direct access key pressed
Bypass Mode	Load supplied from AC input bypass supply.
Normal Mode	Load supplied from Inverter output through double conversion of the AC mains input supply.
Battery Mode	Load supplied from Inverter output through double conversion of the Battery supply.
Source share mode	Load supplied from Inverter output through shared double conversion of the AC mains input supply and of the Battery supply.
UPS Shutdown	UPS Shutdown, output power-down
Check UPS Output	Inverter off during normal startup (diagnostics information only)
Generator Connected	Generator active signal received. Source share mode may be activated pending UPS settings.
BCB open	Battery Circuit Breaker status (open)
BCB closed	Battery Circuit Breaker status (closed)
Battery Float Charging	Battery status (Float charge mode)
Battery Boost Charging	Battery status (Boost charge mode)
Battery Discharging	Battery status (discharge mode)
Battery Period Testing	Automatic periodic battery maintenance discharge test (20% capacity discharge)
Batt. Capacity Testing	User initiated battery capacity discharge test (100% capacity discharge)
Batt. Maint. Testing	User initiated maintenance discharge test (20% capacity discharge)
UPS System Testing	User initiated UPS self test
Inverter in Setting	Inverter starting up and synchronising
Rectifier in Setting	Rectifier starting up and synchronising
MBP-T cabinet Fan Fault	Maintenance bypass cabinet fans fault.
Ext Input TX Overtemp	External Input Isolation Transformer Over Temperature
Ext Output TX Overtemp	External Output Isolation Transformer Over Temperature
Battery Room Alarm	Environment in Battery Room Needs Attention
Rotary Sw. Test Pos.	Rotary switch is in test position.
Rotary Sw. Normal Pos.	Rotary switch is in normal position.
Rotary Sw. Bypass Pos.	Rotary switch is in bypass position.
Rotary Sw. Maint. Pos.	Rotary switch is in maintenance position.
Battery Contactor Open	Battery Contactor Open
Battery Contactor Close	Battery Contactor Closed
Battery Reverse	Connect the battery again and check the wiring of batteries
No Battery	Check the battery and the wiring of batteries
Auto start	After UPS was shutdown at EOD, inverter auto starts when utility restore
Rec. Flash Update	Rectifier firmware is being update
Inv. Flash Update	Inverter firmware is being update
Monitor Flash Update	Monitor firmware is being update
Input contactor fault	Input contactor is in fault
Contactor P.S. 1 fault	Contactor Power Supply board 1 Fault
Contactor P.S. 2 fault	Contactor Power Supply board 2 Fault
LBS abnormal	LBS is abnormal
DSP firmware error	The inverter firmware does not match with the rectifier firmware.

### 7.3 Prompt (Pop-Up) Windows

The prompt window is displayed during the operation of the system to alert the user to certain conditions and / or to require user confirmation of a command.

**Table 23 Prompt windows, meanings**

Prompt	Meaning
Transfer with interrupt, please confirm or cancel	Inverter and Bypass supplies are not synchronised and any load transfer between the supplies will cause a brief load interruption.
The load is too high to be transferred with interrupt	The total load must be less than the capacity of one unit to allow a parallel system to perform an interrupted transfer from bypass to inverter.
This Operation Leads to Output Shutdown, Confirm or Cancel	No alternative supply is available and any Inverter Off operation will cause the load to be de-energised.
This operation leads to inverter overload, confirm or cancel	The turn-off this inverter will lead to the overload of remaining inverter(s) in a parallel system.
Turn on more UPS to carry current load	The number of paralleled inverters already turned on is insufficient to carry the existing load.
Battery will be depleted, confirm	Battery Capacity test discharges the battery 100%
System self test finished - everything is ok.	No action required
System self test finished - Please check the current warnings.	Check "Current Records" window
Enter control password	Required for Battery or UPS test (default = 12345)
Battery Self Test aborted, condition not met	Battery self-test condition is not enough. User should check whether battery state is boost charging and whether load level is greater than 20 percent.
Battery Refresh Charge aborted, condition not met	Boost charging condition is not enough, such as (No battery, charger has failed, etc.).

### 7.4 Dynamic Energy Flow Chart and UPS Help Screen

This screen displays a mimic diagram of the UPS that includes energy flow and status of isolation and transfer switches. Press the "Help" key to activate this screen. Press again to toggle between this screen and the main screen.

**Figure 34 Help screen**

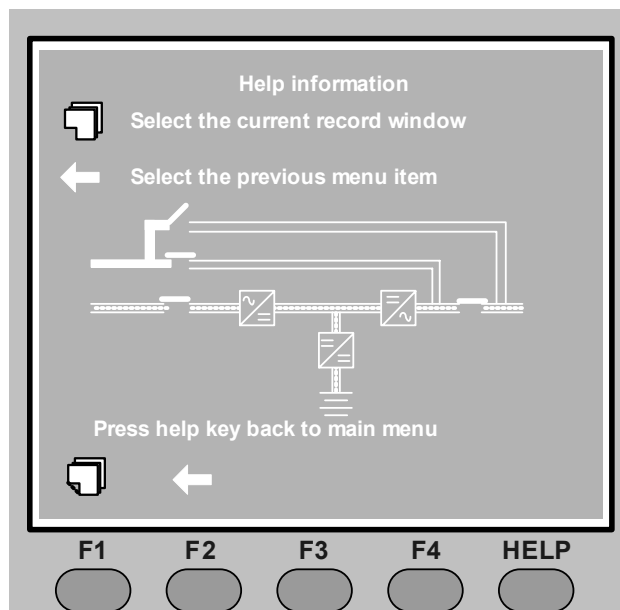



## 7.5 Default Screen Saver

This default screen is displayed following at least 2 minutes of operation with no new alarm. After another delay, the backlight turns off. Press any key (F1-F4 or Help) to reactivate the screen.

Figure 35 Default screen

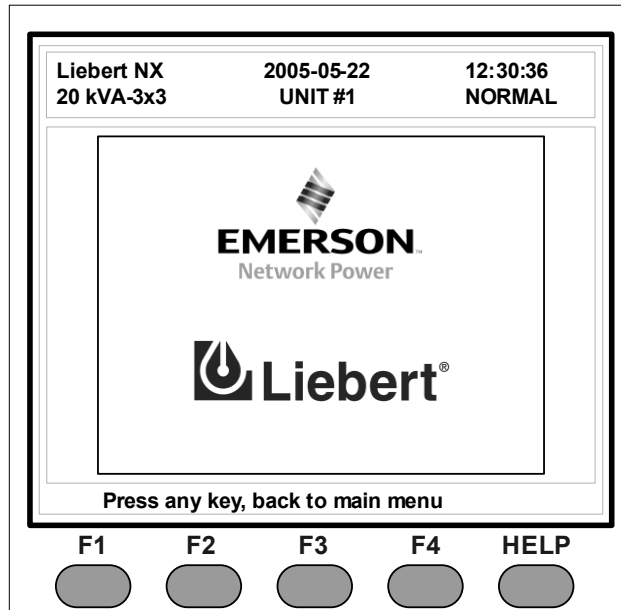

## 8.0 OPTIONS—FOR ASSEMBLY INSIDE THE UPS CABINET

Several items of optional equipment are available for connection to the Liebert NX UPS. These are described in this section of the manual and should be fitted prior to installation.

### 8.1 Protection

#### 8.1.1 Battery Ground Fault Detection

In addition to any residual current device mounted externally and upstream the UPS or when optional isolation transformers are fitted to the UPS, an optional residual battery current device can be fitted to detect leakage current from the battery into the PE (Protective Earth) Residual current range monitored: 30~3000mA.

Power supply voltage for the set: AC230V (L-N);

When a battery ground fault is detected, an alarm will appear on the UPS display panel.

An additional Dry contact fault Alarm signal is available for remote monitoring:

**Table 24 Dry contact fault alarm signal is available for remote monitoring**

Terminal	Name	Definition
21	Common	Battery Ground Fault Detection – can be programmed as Alarm or Pre-Alarm
22	NC	
24	NO	

The Battery ground fault detection set contains one CT (current transformer) and one DC sensitive residual current monitor. The connection of this set for UPS is illustrated as follows.

**Figure 36 Battery ground fault detection set connections**

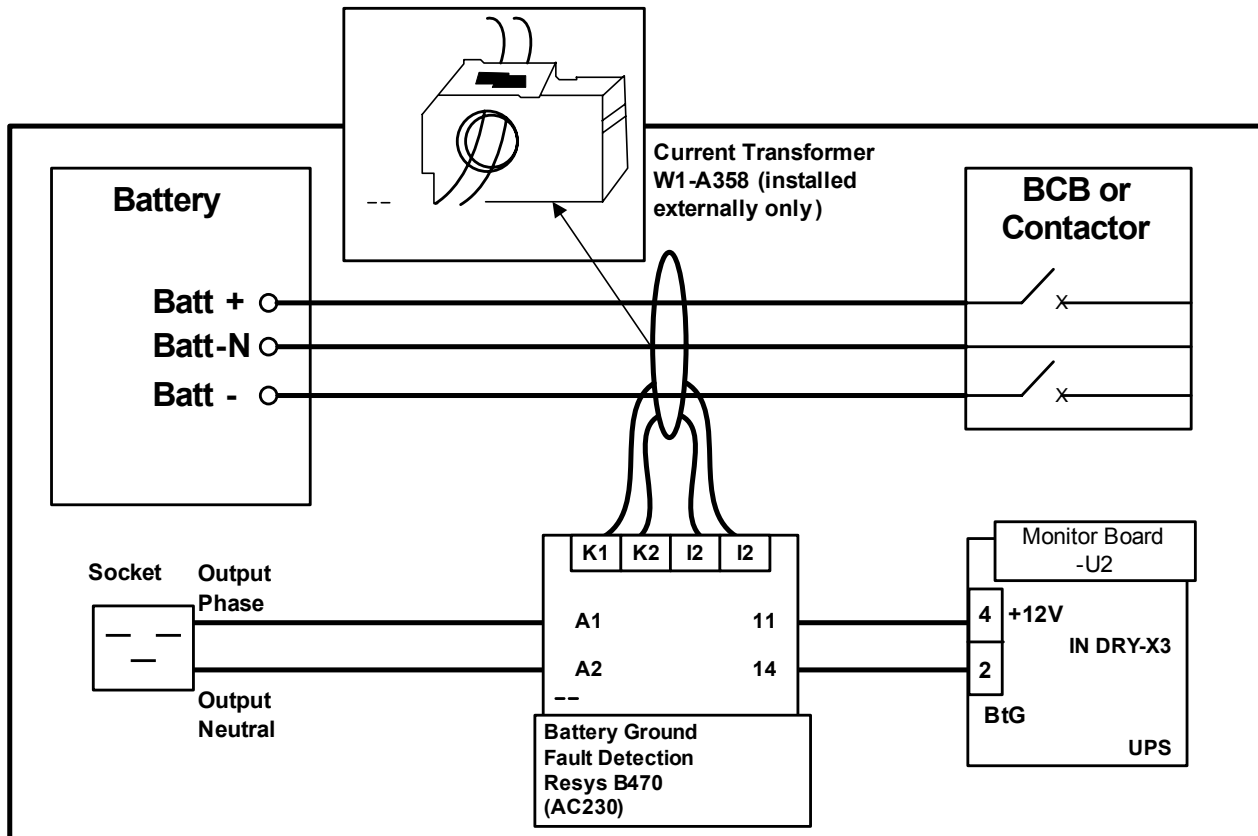

### 8.1.2 Redundant Fan for Power Module

In addition, to ensure sufficient cooling power at various operation modes with 100% rated load, a redundant power module fan set can be supplied, thus ensuring continuity of UPS operation even with the failure of some fans. No extra footprint is required.

Figure 37 Redundant power module fan set

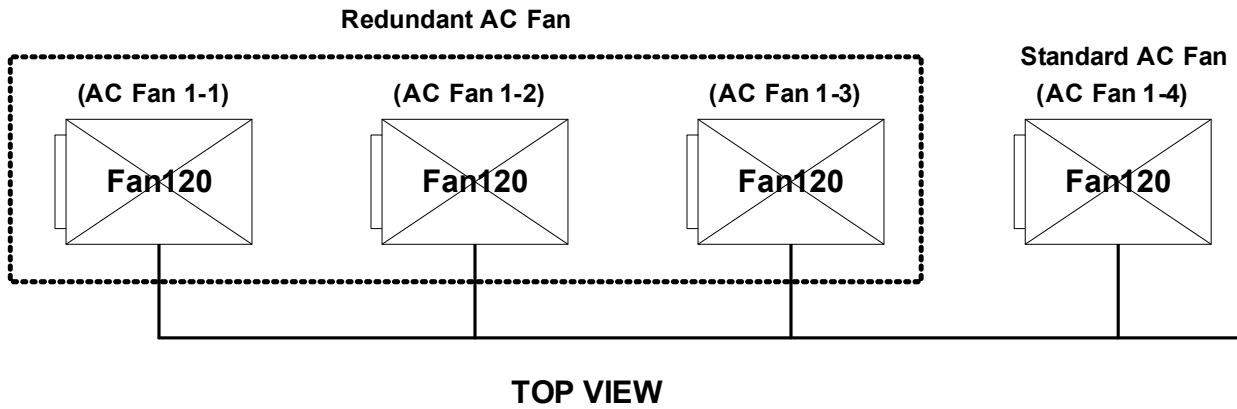

Figure 38 Communication bays and cable location

Location	Preferred Device This Location
RS-232-1 DB-9 (COM Port 1)	Serial MultiLink Software (Port Setting 2400 Baud)
RS-232-2 DB-9 (COM Port 2)	Service Access Software (Port Setting 9600 Baud)

Location	Preferred Device This Location
Top Bay	Relay Card (no port setting required)
Mid Bay	Multiport4 (no port setting required)
Bottom Bay	OCWeb LB / OC485 (port setting 2400 Baud)

**Top**  
**Mid**  
**Bottom**

**Suggested routing of customer-supplied communication cables**

**Notes:**

- a) All Intellislot cards are supported in any bay.
- b) Port sharing is:
  - PERMITTED between RS232-x DB9 devices and Relay / Multiport4 Intellislot cards (i.e., Serial Multilink software will work from RS232-1 DB9 also when relay card is inserted in the top bay.
  - NOT PERMITTED between RS-232-x D-B9 devices and OCWeb / OC485 cards (i.e., Serial MultiLink software will not work from RS232-1 DB-9 when OCWeb card is inserted in the top bay.

**Gland plate for cable exit**

### 8.1.3 OC Web Card - SNMP/HTTP Network Interface Card

This network interface card provides all real-time data and status information as SNMPv1 traps for connection to a 10/100-baseT Ethernet network and in addition the same card will also transmit the same status information and all measured parameters for display via a Web browser.

This card is supported in the top, middle and bottom Intellislot bays.

Figure 39 OC Web Card data summary window

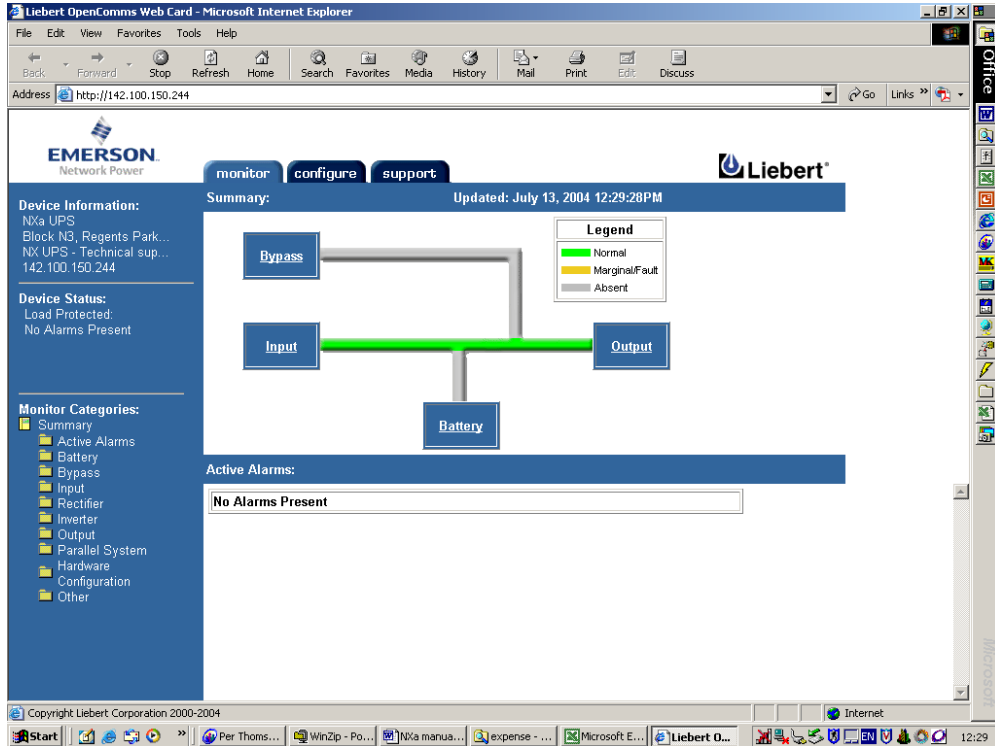
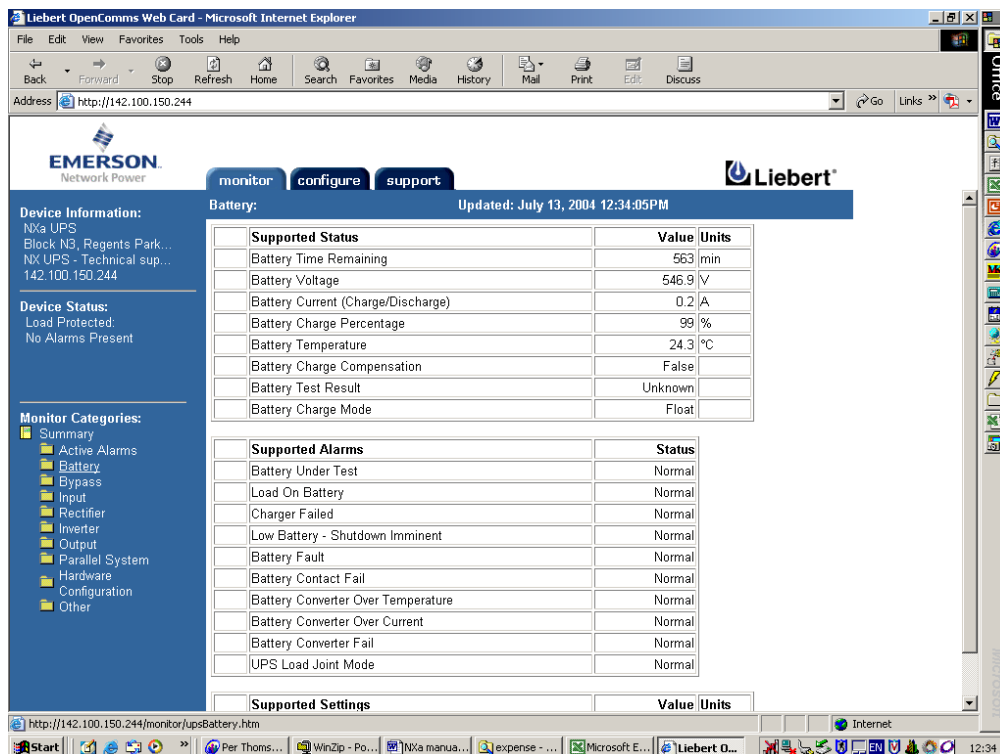

Figure 40 OC Web Card battery data summary



### 8.1.4 Relay Card

The Relay card provides voltage-free contact closures for remote monitoring of alarm conditions.

Delivering On Battery, On Bypass, Low Battery, Summary Alarm, UPS Fault and On UPS signals, the easy-to-install card integrates with AS/400 computers (additional cable required) and other relay contact monitoring systems.

The Relay card is rated for 24 VAC/VDC at 1A and supported in any of the three NX Intellislot bays.

**Table 25 Relay Card pin configuration**

Pin	Function	Operation
1	UPS Fault	Closed if no UPS failure
2-3	Not Used	
4	UPS Fault	Closed if UPS fails
5	Summary Alarm**	Closed if SUMMARY ALARM** occurs
6	Summary Alarm**	Closed if no alarm conditions are present
7	Any Mode Shutdown return	Not Supported– use External EPO terminal
8	Not Used	
9	Common - Low Battery	
10	Low Battery	Closed if battery is OK
11	Low Battery	Closed if LOW BATTERY point occurs.
12-13	Not Used	
14	UPS Any Mode Shutdown	Not supported– use External EPO terminal
15	On UPS	Closed if ON UPS (inverter) power
16	On Battery	Closed if ON BATTERY power (Utility failure)
17	Common - UPS Fault, Summary Alarm, On UPS, On Battery, On Bypass	
18	On Battery	Closed if not ON Battery power (Utility OK)
19 ÷ 23	Not Used	
24	On Bypass	Closed if ON BYPASS
25	Not Used	

\*\*A *Summary Alarm* occurs when any of the following conditions exist:

- Utility power is out of the acceptable range (voltage and/or frequency)
- UPS is in BYPASS MODE (load not on Inverter power)
- UPS Battery is LOW
- UPS fault has occurred

**Table 26 Relay card jumpers**

#	Connection	Description
JP01	Pin 9 to Pin 17	Allows all relay COMMONS to be tied together.
JP02	Pin 7 to Pin 17	Irrelevant for NX - (Interconnects all relay COMMONS and the (not supported) ANY MODE SHUTDOWN Return.

### 8.1.5 Multiport-4 Card

The Multiport-4 card provides 4 sets of voltage-free contact closures for remote monitoring of alarm conditions UPS operation On Battery and battery low condition. A typical application is to allow a maximum of four computer systems to simultaneously monitor the status (e.g., utility power failure / low battery) of a single UPS.

This card is supported in any of the three NX Intellislot bays.

Figure 41 SiteNet MultiPort4 Intellislot pin configuration

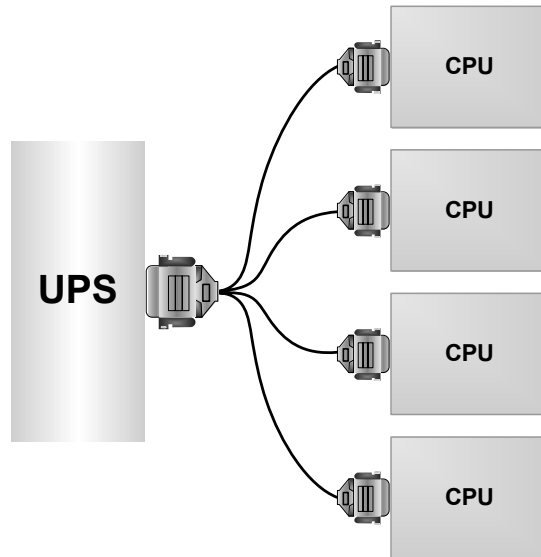

Table 27 SiteNet MultiPort4 Intellislot pin assignment

Pin	Assignment Description
1	Low Battery
2	Not Used
3	Not Used
4	Not Used
5	Not Used
6	Not Used
7	Low Battery Common
8	Utility Fail Common
9	Utility Fail

## 8.2 OC485 Web Card – Modbus, Jbus, IGM Net

The OpenComms 485 Card facilitates SiteScan Web or Building Management Systems monitoring. The RS232 port is used for connection to a personal computer for setting up.

The RS-485 port supports IGM Net and Modbus/JBus protocols and maps the operation of the UPS including status, alarms and data (voltages, currents, frequency, power, power factor, temperatures etc.)

Figure 42 OC485 Web card



Table 28 NX communication options

Physical description of port	Labeled ID Name of Port	On the UPS LCD screen, under Settings, controlled by:	Monitoring Devices supported	Baud rate	Comments
Top Intellislot	Intellislot 2 (On Monitor Board)	Comm 1	Multiport 4	any	
			Relaycard-int	any	
			OCWEB-LB	2400	Not simultaneous with Multilink in RS232-1
			Modbus/Jbus	2400	
Middle Intellislot	Intellislot 1 (On Monitor Board)	Comm 2	Multiport 4	any	
			Relaycard-int	any	
			OCWEB-LB	2400	Not simultaneous with Multilink in RS232-2
			Modbus/Jbus	2400	
Bottom Intellislot	Intellislot 3 (On Monitor Board)	Comm 3	Multiport 4	any	
			Relaycard-int	any	
			OCWEB-LB	2400	
			Modbus/Jbus	2400	
Top DB9 port	RS232-1	Comm 1	Multilink Serial	9600	Not simultaneous with Web card in top Intellislot.
Bottom DB9 port	RS232-2	Comm 2	Service Software (Reserved)	9600	Not simultaneous with Web card in middle Intellislot.

### 8.2.1 Remote Alarm Monitor

Status and alarm conditions are available on an optional remote alarm monitor (RAM) panel that is driven by volt-free alarm status contacts from an optional relay alarm board.

## 8.2.2 Dust Filter for 10-30kVA

Installing the two dust filters in the Liebert NX requires only a Phillips screwdriver. Each filter is held in place by a bracket on either side of each filter. To install each filter:

1. Open the UPS door and locate the filters (on the back side of the front door; see **Figure 43**).
2. Remove one bracket and loosen the screw on the second bracket. The second bracket need not be removed (see **Figure 43**).
3. Remove the dust filter to be replaced.
4. Insert the clean filter.
5. Reinstall the bracket, tightening the screw securely.
6. Tighten the screw on the second bracket.

**Figure 43** Dust filter replacement

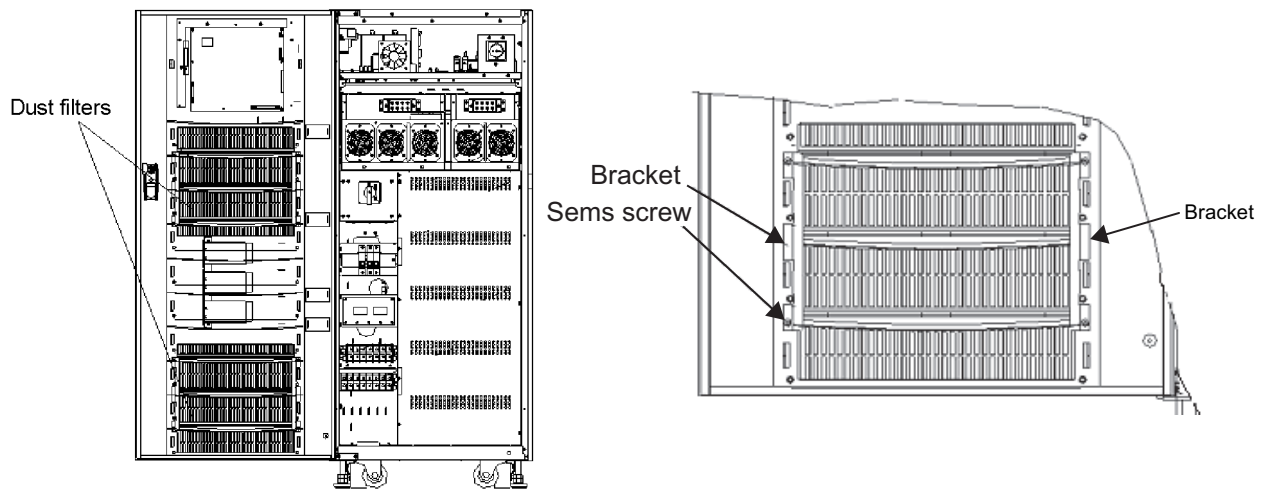



## 9.0 TECHNICAL SPECIFICATIONS

### 9.1 Conformity and Standards

The UPS has been designed to conform to the following European and international standards:

**Table 29 Compliance with European, international standards**

Description	Normative reference
General and safety requirements for UPS used in operator access areas	EN 50091-1-1 / IEC 62040-1-1 / AS 62040-1-1
Electromagnetic compatibility (EMC) requirements for UPS	EN 50091-2 / IEC 62040-2 / AS 62040-2 (Class A)
Method of specifying the performance and test requirements of UPS	EN 50091-3 / IEC 62040-3 / AS 62040-3 (VFI SS 111)

The product standards in **Table 29** incorporate relevant compliance clauses with generic IEC and EN standards for safety (IEC/EN/AS60950), electromagnetic emission and immunity (IEC/EN/AS61000 series) and construction (IEC/EN/AS60146 series and 60529).

**Table 30 Environmental characteristics**

Rated power, kVA	Unit of Measurement	10	15	20	30
Acoustic Noise Level at 1 Meter (39 in)	dBa	51.0	51.5	51.6	56
Altitude of Operation	m (ft)	≤1000m (3280 ft) above sea level de-rate power by 1% per 100m(328 ft) between 1000 and 2000 m (3280 and 6560 ft)			
Relative Humidity	-	0 to 95% non condensing			
Operating Temperature	°C (°F)	0 to 40 (32-104°) Battery life is halved for every 10° (18°) increase above 20° (68°)			
Storage-Transport Temperature for UPS	°C (°F)	-20 to 70 (-4 to 158)			
Recommended Battery Storage Temperature	°C (°F)	-20 to 30 (-4 to 86)°F (20°C [68°F] for optimum battery storage)			

**Table 31 Overall efficiency, heat losses and air exchange**

Rated Power, kVA	Unit of Measurement	10	15	20	30
Normal Mode (dual conversion)	%	90.4	91.2	91.3	91.9
ECO Mode	%	93.2	94.2	94.7	96.6
<b>Inverter Efficiency (DC/AC) (battery at nominal voltage 480VDC and full-rated linear load)</b>					
Rated Power,	kVA	10	15	20	30
Battery Mode	%	91.3	91.7	92.0	92.5
<b>Heat Loss &amp; Air Exchange (Ventilation)</b>					
Rated Power	kVA	10	15	20	30
Normal Mode	kW	1.6	1.8	2.2	2.6
ECO Mode	kW	1.3	1.4	1.4	1.5
No Load	kW	1.3	1.3	1.3	1.3
Maximum Forced Air Cooling (front intake, back exhaust)	L/sec (m <sup>3</sup> /hr)	119 (428)	239 (860)		

Input and output voltage 400VAC, battery charged, full rated linear load

**Table 32 Mechanical characteristics**

Rated Power, kVA	Unit of Measurement	10	15	20	30
Dimensions, WxDxH	mm (in)	600x700x1400 (23-9/16x27-5/8x55)			
<b>Mass</b>					
Mass without batteries	kg (lb)	180 (397)	204 (450)	204 (450)	210 (463)
Finish	N/A	Pantone 877 (Silver grey) equivalent Becker Silver epoxy polyester powder 041-37-2			
Protection Degree, IEC (60529)	N/A	IP20 (finger-proof with front doors open or closed)			

**Table 33 Rectifier AC input (mains)**

Rated Power, kVA	Unit of Measurement	10	15	20	30
Rated AC Input Voltage <sup>1</sup>	VAC	380/400/415 (3-phase and sharing neutral with the bypass input)			
Input Voltage Tolerance <sup>2</sup>	VAC	305V to 477V 304V to 208V (output derated below 70%)			
Frequency <sup>2</sup>	Hz	50/60Hz (tolerance 40Hz to 70Hz)			
Power Factor	kW/kVA, full load (half load)	0.99 (0.98)			
Input Power	kVA rated <sup>3</sup> (maximum <sup>4</sup> )	8.9 (11.7)	13.3 (18.9)	17.8 (23.3)	26.6 (35.0)
Input Current	A rated <sup>3</sup> (maximum <sup>4</sup> )	12.9 (16.9)	19.3 (27.4)	25.8 (33.8)	38.6 (50.7)
Harmonic Current Distortion	THDI % FL	3	3	3	3
Duration of Progressive Power Walk-In	sec	10 seconds to reach full rated current (selectable 5 through 30 seconds in 5-second intervals)			

1. Rectifier operates at any of the rated supply voltages and frequencies without further adjustment.
2. At 305V input mains the UPS maintains the specified output voltage at rated load without discharging a previously charged battery
3. IEC 62040-3 / EN 50091-3: at rated load and input voltage 400V, battery charged
4. IEC 62040-3 / EN 50091-3: at rated load and input voltage 400V, battery charging at maximum rated power.

**Table 34 Battery**

Intermediate DC Circuit					
Rated Power, kVA	Unit of Measurement	10	15	20	30
<b>Battery Bus Voltage</b>	VDC	Nominal: 480V (VRLA Float charge is 540V) Range: 400V - 616V			
<b>Number of Lead-Acid Cells</b>					
Nominal		240 = [40 x 6-cell (12V) blocks]			
Maximum		264 = [44 x 6-cell (12V) blocks]			
<b>Float Voltage</b>	V/cell (VRLA)	2.25 V/cell (selectable from 2.2 – 2.3V/cell) Constant current and constant voltage (IU) charge mode			
<b>Temperature Compensation</b>	mV/°C/cl	- 3.0 (selectable 0 to – 5.0 around 25°C or 30°C. or inhibit)			
<b>Ripple Voltage</b>	% V float	≤1			
<b>Ripple Current</b>	% C <sub>10</sub>	≤5			
<b>Boost Voltage</b>	V/cell (VRLA)	2.35 V/cell (selectable from 2.30-2.40V/cell) Constant current and constant voltage (IU) charge mode			
<b>Boost Control</b>		- float-boost current trigger 0.050 C <sub>10</sub> (selectable 0.030-0.070) - boost-float current trigger 0.010 C <sub>10</sub> (selectable 0.005-0.025) with 24 hr safety timeout (selectable 8-30 hr) - boost mode inhibit also selectable			
<b>End Of Discharge</b>	V/cell (VRLA)	1.63 V/cell (selectable from 1.60~1.75 V/cell) Auto Inverse EOD voltage x discharge current mode (The end of discharge voltage increases at low discharge currents).			
<b>Battery Charge</b>	V/cell	2.4 V/cell (selectable from 2.3-2.4V/cell) Constant current and constant voltage (IU) charge mode Programmable auto trigger or inhibit of boost mode			
<b>Battery Charging Power* max current (adjustable) 1</b>	kW	2.5	5	5	7.5
	A	3.75	7.5	7.5	12

\* At low input voltage the UPS recharge capability increases with load decrease (up to the maximum capacity indicated)

1. Max currents listed are for EOD voltage of 1.67 V/cell for 240 cells.

**Table 35 Inverter output to critical load**

Rated Power, kVA (kW)	Unit of Measurement	10 (8)	15 (12)	20 (16)	30 (24)
<b>Rated AC Voltage</b> <sup>1</sup>	VAC	380/400/415 V (three-phase, four-wire with neutral referenced to the bypass neutral)			
<b>Frequency</b> <sup>2</sup>	Hz	50 / 60			
<b>Overload</b>	% Rated	110% for 60 min 125% for 10 min 150% for 1 min >150% for 200 msec			
<b>Fault Current</b>	% Rated	340% current limitation for 200 msec			
<b>Non linear load capability</b> <sup>3</sup>	% Rated	100%			
<b>Neutral current capability</b>	% Rated	170%			
<b>Steady state voltage stability</b>	%	±1 (balanced load), ±2 (100% unbalanced load),			
<b>Transient voltage response</b> <sup>4</sup>	%	± 5			
<b>Total Harmonic Voltage Distortion (THDV)</b>	%	< 1 (linear load), < 4 (non linear load <sup>3</sup> )			
<b>Synchronisation - Window</b>		Rated frequency ± 2Hz (selectable ± 0.5 to ± 3Hz)			
<b>Slew Rate (Max change rate of synch frequency)</b>	Hz sec	1 Hz/sec selectable 0.1 to 3Hz/s (single UPS) 0.2Hz/sec (paralleled UPS)			
<b>Inverter Voltage Tolerance</b>	%V (AC)	±5			

1. Factory set to 400V – 380 or 415V selectable by commissioning engineer.

2. Factory set to 50Hz; 60 Hz selectable by commissioning engineer. Frequency converter operation also selectable.

3. EN 50091-3 (1.4.58) crest factor 3:1

4. IEC 62040-3 / EN 50091-3 also for 0-100-0% load transient. Transient recovery time: return to within 5% of steady state output voltage within half a cycle.

**Table 36 Bypass mains input**

Rated power, kVA	Unit of Measurement	10	15	20	30
Rated AC Voltage <sup>1</sup>	VAC	380/400/415 V three-phase four-wire, sharing neutral with the rectifier input and providing neutral reference to the output			
<b>Rated Current</b>					
380V	A	15	23	30	45
400V	A	15	22	29	43
415V	A	14	21	28	42
Overload Capacity	%	135% long term 170% 10 min 1000% 100 ms			
Upstream Protection, Bypass Line (by others)	N/A	Thermomagnetic circuit breaker, rated up to 125% of nominal output current. IEC 60947-2 curve C.			
Current Rating of Neutral Cable	A	1.7 x In			
Frequency <sup>2</sup>	Hz	50 / 60			
Transfer Time (between bypass and inverter)	ms	Synchronous transfer: ≤1ms Asynchronous transfer (default): 15 ms (50 Hz), 13.3 ms (60 Hz) or 40, 60, 80, 100 ms, selectable			
Bypass Voltage Tolerance	% VAC	Upper limit: +10, +15 or +20, default +15 Lower limit -10, -20, -30 or -40, default: -20 (delay time to accept steady bypass voltage: 10 sec)			
Bypass Frequency Tolerance	%	± 2.5 ± 5 ± 10 or ± 20 default ±10			
Synchronisation - Window	Hz	Rated frequency ±2Hz (selectable ± 0.5 to ±3Hz)			

1. Factory set to 400V – 380 or 415V selectable by commissioning engineer.

2. Factory set to 50Hz; 60 Hz selectable by commissioning engineer. Bypass condition ignored when UPS set as frequency converter.

## NOTES





# Ensuring The High Availability Of Mission-Critical Data And Applications.

Emerson Network Power, the global leader in enabling business-critical continuity, ensures network resiliency and adaptability through a family of technologies—including Liebert power and cooling technologies—that protect and support business-critical systems. Liebert solutions employ an adaptive architecture that responds to changes in criticality, density and capacity. Enterprises benefit from greater IT system availability, operational flexibility and reduced capital equipment and operating costs.

## Technical Support / Service Web Site

[www.liebert.com](http://www.liebert.com)

### Monitoring

800-222-5877

[monitoring@liebert.com](mailto:monitoring@liebert.com)

Outside the US: 614-841-6755

### Single-Phase UPS

800-222-5877

[upstech@liebert.com](mailto:upstech@liebert.com)

Outside the US: 614-841-6755

### Three-Phase UPS

800-543-2378

[powertech@liebert.com](mailto:powertech@liebert.com)

### Environmental Systems

800-543-2778

Outside the United States

614-888-0246

### Locations

#### United States

1050 Dearborn Drive

P.O. Box 29186

Columbus, OH 43229

#### Europe

Via Leonardo Da Vinci 8

Zona Industriale Tognana

35028 Piove Di Sacco (PD) Italy

+39 049 9719 111

Fax: +39 049 5841 257

#### Asia

7/F, Dah Sing Financial Centre

108 Gloucester Road, Wanchai

Hong Kong

852 2572220

Fax: 852 28029250

While every precaution has been taken to ensure the accuracy and completeness of this literature, Liebert Corporation assumes no responsibility and disclaims all liability for damages resulting from use of this information or for any errors or omissions.

© 2006 Liebert Corporation

All rights reserved throughout the world. Specifications subject to change without notice.

® Liebert and the Liebert logo are registered trademarks of Liebert Corporation. All names referred to are trademarks or registered trademarks of their respective owners.

SL-25410\_REV2\_08-06

## Emerson Network Power.

The global leader in enabling Business-Critical Continuity™.

■ AC Power Systems ■ Embedded Computing

■ Connectivity ■ Embedded Power

■ DC Power Systems ■ Integrated Cabinet Solutions

■ Outside Plant

■ Power Switching & Control

■ Precision Cooling

## EmersonNetworkPower.com

■ Services

■ Site Monitoring

■ Surge Protection

Business-Critical Continuity, Emerson Network Power and the Emerson Network Power logo are trademarks and service marks of Emerson Electric Co.

©2006 Emerson Electric Co.



## Free Manuals Download Website

<http://myh66.com>

<http://usermanuals.us>

<http://www.somanuals.com>

<http://www.4manuals.cc>

<http://www.manual-lib.com>

<http://www.404manual.com>

<http://www.luxmanual.com>

<http://aubethermostatmanual.com>

Golf course search by state

<http://golfingnear.com>

Email search by domain

<http://emailbydomain.com>

Auto manuals search

<http://auto.somanuals.com>

TV manuals search

<http://tv.somanuals.com>