

# User and Installation Instructions

for fridge-freezer combination

GB

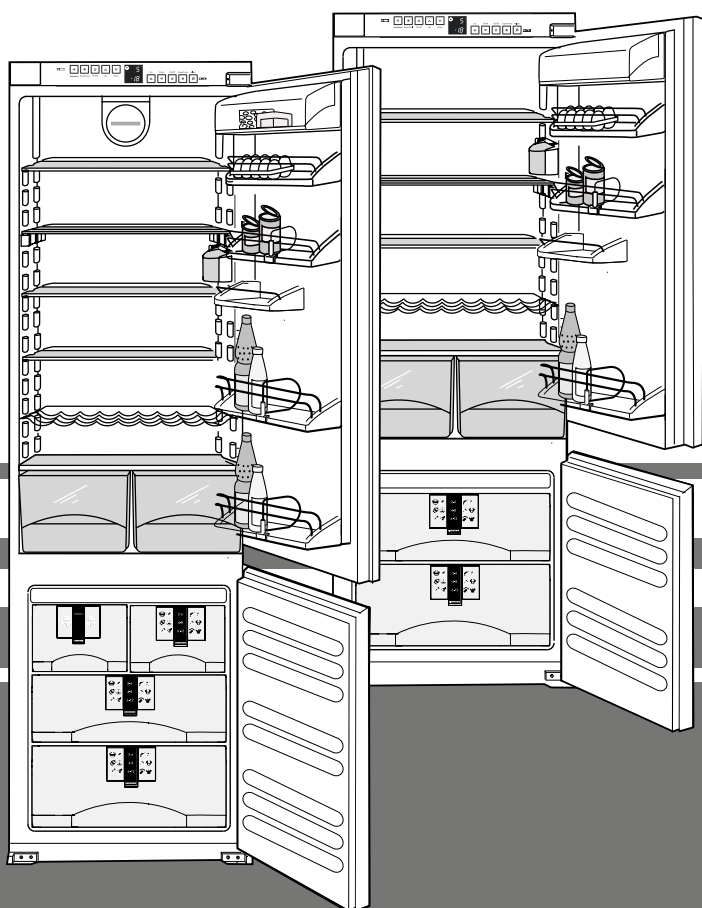

**7082 532-00**

IC/ICN...6 0507

# The appliance at a glance

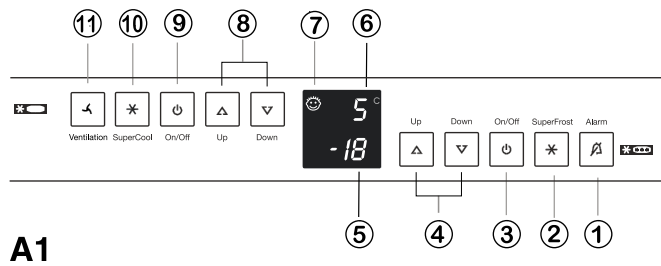

**A1**

## Operating and control panel, Figure A1

### Freezer section

- ① Alarm off button for audible warning signal
- ② SuperFrost button with light emitting diode (LED) display, when lit = it is switched on
- ③ Appliance main on/off switch
- ④ Temperature setting buttons: left hand button = warmer, right-hand button = colder, recommended setting: -18 °C
- ⑤ Temperature and settings display

### Fridge section

- ⑥ Temperature and settings display
- ⑦ Child lock (display for fridge and freezer sections)
- ⑧ Temperature setting buttons: left hand button = warmer, right-hand button = colder, recommended setting: 5 °C
- ⑨ Fridge off button
- ⑩ SuperCool button with LED display, when lit = function is switched on
- Ⓜ Fan button

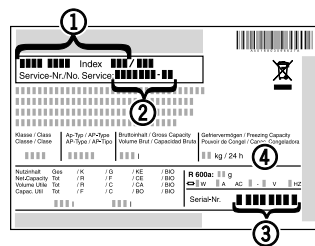

## Type plate, Fig. A3

- ① Appliance designation
- ② Service number
- ③ Serial no.
- ④ Freezing capacity in kg/24 hours

**A2**

## Overview of the appliance and options, Fig. A

### Fridge section, approx. 5 °C

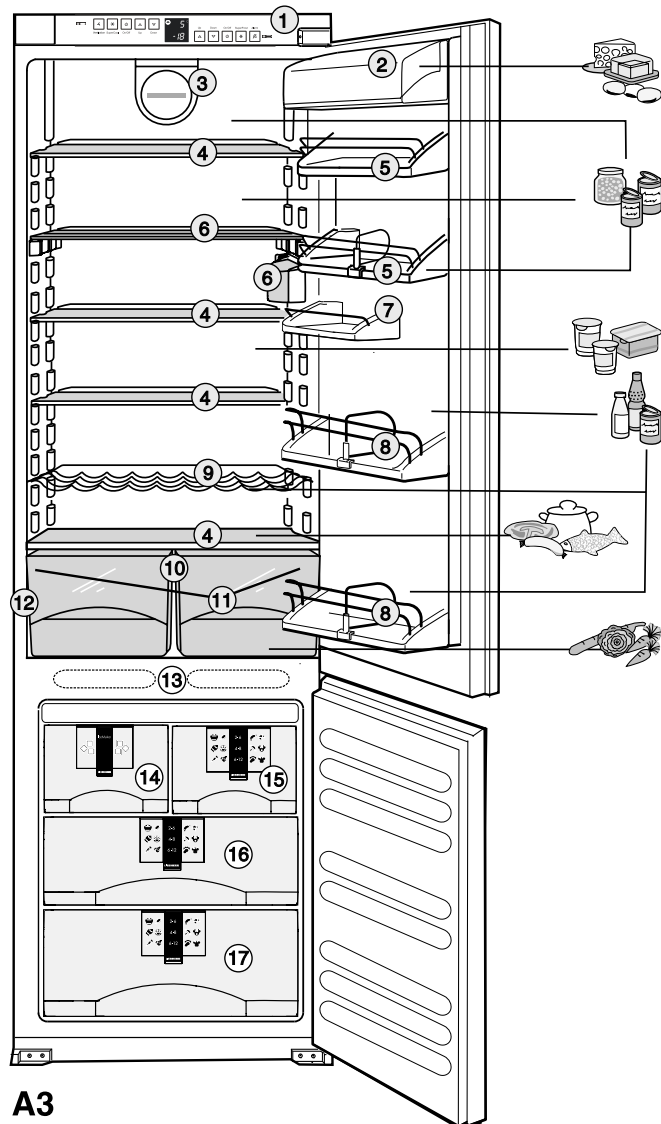

### Freezer section, approx. -18 °C

- ① Operating and control panel
- ② Butter and cheese compartment
- ③ Fan
- ④ adjustable storage surface
- ⑤ Preserves rack
- ⑥ LED lighting\*
- ⑦ Egg shelf\*
- ⑧ Tall bottle and drinks shelf
- ⑨ Bottle rack
- ⑩ Vegetable drawers
- ⑪ Defrost water drain
- ⑫ Type plate

### Freezer section, approx. -18 °C

- ⑬ Cold accumulator\*
- ⑭ Ice cube maker\*
- ⑮ Drawers with information system\*
- ⑯ VarioSpace with drawer enlarger\*, Freezer tray, cold accumulator (on NoFrost appliances)\*
- ⑰ Drawers with information system\*

**A3**

Keep these user instructions in a safe place and, if appropriate, hand them to the next owner of the appliance. The instructions apply to several models, so may vary slightly.

## Contents

The appliance at a glance .....	14
Conditions .....	15
Safety information and warnings .....	15
Information concerning disposal .....	15
Technical safety .....	15
Safety in use .....	15
Installation and ventilation information .....	16
Energy saving information .....	16
Connection .....	16
Putting into operation and controls.....	16
Switching the appliance on and off .....	16
Setting the temperature .....	16
Temperature display .....	16
Alarm - audible signal .....	17
Ventilation .....	17
SuperCool .....	17
Power failure/"FrostControl" display .....	17
Additional functions .....	17
Net@Home .....	17
Fridge section .....	18
Organising food storage.....	18
Information about keeping food cool.....	18
Changing the layout.....	18
Freezer section .....	18
SuperFrost.....	18
Freezing with SuperFrost .....	18
Freezing and storage information.....	18
The Information System*.....	19
The freezer tray.....	19
The cold accumulators* .....	19
VarioSpace*.....	19
Defrosting, cleaning.....	20
Information about defrosting .....	20
Cleaning .....	20
Faults - problems? .....	20
Customer services and type plate.....	21
Installation instructions .....	21
Installation information.....	21
Replacing the door stop.....	22
Fixing and assembly .....	23
Fitting the kitchen unit door.....	24

## Conditions

- The appliance is intended for use to cool, freeze and store food, and to make ice. It is designed for household use. No guarantee is given that the appliance will work perfectly if it is used for any other purpose.
- Depending on its climate class, the appliance is designed for operation within certain ambient temperature limits. These upper and lower limits must not be exceeded! The climate class for your appliance is printed on the type plate. It means:

Climate class	for ambient temperatures from
SN	+10 °C up to +32 °C
N	+16 °C up to +32 °C
ST	+18 °C up to +38 °C
T	+18 °C up to +43 °C

- The coolant circuit has been tested for seal.
- When installed, the appliance complies with all relevant regulations and the 73/23/EEC and 89/336/EEC Directives.

## Safety information and warnings

### Information concerning disposal



Your fridge/freezer is packed in recyclable packaging.

- Corrugated cardboard/cardboard
- Moulded polystyrene foam
- Polyethylene film
- Polypropylene straps

- **Do not allow children to play with packaging materials - the film can be a suffocation hazard!**
- Take the packaging materials to a public amenity site.

**The old appliance:** This still contains valuable materials and should be sent to a special facility, separate from unsorted municipal waste.



- Make sure that the old appliance cannot be used. Remove the plug, cut through the connection cable, and make sure the lock cannot engage, so that children cannot get locked inside.
- When transporting the used appliance make sure that the coolant circuit cannot be damaged.
- Please see the type plate for information about the coolant.
- The old appliance must be disposed of in a proper manner in accordance with local regulations and legislation.

### Technical safety



- To avoid personal injury and material damage the appliance must be transported only in a packed condition, with two people to carry it.
- The coolant, R 600a, is environmentally friendly, but it is flammable.
- Do not damage the coolant pipes. Coolant emerging in a spray can cause injuries to eyes, or can ignite.
- In the event that coolant should escape, remove any naked flames or sources of ignition in the vicinity of the leak, remove the plug, and ventilate the room well.
- If the appliance is damaged, contact your supplier immediately - before plugging it in.
- To ensure safe operation, the appliance should be assembled and connected only in accordance with the user instructions.
- In the event of a fault, disconnect the appliance from the mains: pull out the plug (do not tug on the cable) or trip/unscrew the fuse.
- **Only customer services should carry out any repairs or interventions on the appliance. A breach of this instruction could cause considerable danger to the user.** The same applies when replacing the mains connection cable.

### Safety in use



- Do not use the appliance to store explosive materials or aerosol cans with flammable propellants, such as butane, propane, pentane etc. The electrical components could cause any gas emerging from these to ignite. You can recognise aerosol cans of this type from the list of contents printed on them, or from the flame symbol.
- Always store high-percentage alcoholic drinks in a sealed container, and standing up.
- Do not use a naked flame or other source of ignition to look inside the appliance.
- Do not use any electrical appliances (such as steam cleaners, heaters, etc.) inside the appliance.
- Do not use the base, the drawers, or the doors etc as a step or to act as a support.

GB

- This appliance is not suitable for people (including children) with physical, sensory or mental problems, or for people who do not have sufficient experience and knowledge, unless they are instructed in using the appliance, or are supervised initially by a person who is responsible for their safety. Children must be supervised, to ensure that they do not play with the appliance.
- Avoid continuous skin contact with cold surfaces or with cool and frozen food. This can cause pain, numbness and freezing. If you are likely to have extended skin contact, take precautions, such as wearing gloves.
- Do not consume edible ice, particularly water ice and ice cubes, immediately after you have taken them out of the freezer. The very low temperatures can cause "burning".
- Do not consume food that has been stored for too long, since this can cause food poisoning.

### Installation and ventilation information

- When erecting/installing the appliance, make sure that the coolant pipes are not damaged.
- **Do not move the ventilation cross-sections. Always make sure that air can circulate around the appliance for ventilation purposes!**
- To comply with the EN 378 standard the position in which you erect your appliance must indicate a volume of 1 m<sup>3</sup> for each 8g of R600a coolant<sup>3</sup> so that in the event of a leak from the coolant circuit a flammable gas/air mixture cannot arise inside the room where the appliance is positioned. Please see the type plate inside the appliance for information regarding the quantity of coolant.
- Please also see the appendix of the installation instructions.
- Once the appliance is installed: Remove all the transport safety devices,
  - Remove all sticky tape or spacers\* from the shelves and adjust them to the heights you require.
  - Remove all protective film: from the decorative strips and the fronts of the drawers.

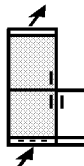

### Connection

#### Electric current (alternating current) and voltage

The information on the type plate must conform with the location. The type plate is located inside the appliance on the left, fig.A.



- **The appliance must be connected using a properly installed shock-proof plug.**
- The plug must be fused with a 10A or higher fuse, and must be located outside the rear of the appliance, and must be easy to access.
- The appliance **must not**
  - be connected to stand-alone inverters,
  - be operating in conjunction with so-called energy-saving plugs. This can damage the electronics,
  - be connected via an extension lead and with other appliances - there is a danger of overheating.
- When removing the mains cable from the side of the appliance, remove the **cable retainer** otherwise there could be vibratory noise!

### Energy saving information

- Make sure the appliance is in a well ventilated position.
- Open the appliance doors for as short a time as possible.
- Arrange the food in an organised way. Do not exceed stated storage periods.
- Store all food well packed and covered, this avoids frost from forming.
- Allow hot food to cool down to room temperature before placing inside the appliance.
- Allow frozen food to defrost inside the fridge.
- In the event of a fault, keep the door closed. This delays the cold loss. The quality of the frozen food will keep for longer.

## Putting into operation and controls

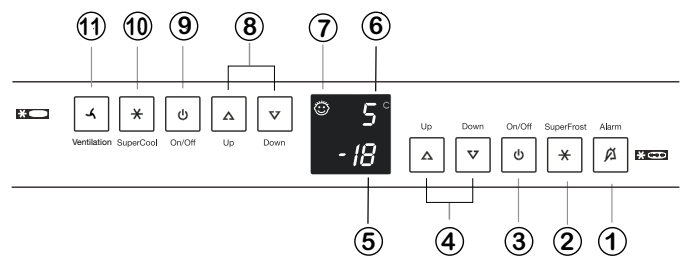

We recommend that you clean the appliance before putting it into operation, please see the section on "Cleaning" for further information.

The appliance should have been operating for about 2 hours before you stock it with frozen food. Only place frozen food in the freezer once the temperature has reached at least -18°C.

### Switching on and off

The entire appliance is always switched on at the main on/off switch ③, both the freezer and the fridge sections.

- **Switching on:** Press the on/off switch ③ so that the temperature displays light up/flash.
  - **Refrigerator section:** The inside light comes on when the door is open.
  - **Freezer section:** While the appliance is being put into operation, and it is still warm, the freezer section display indicates **dashes** until the temperature goes below 0°C.
- **Switching off:** Hold the main on/off switch ③ for about a second, so that the temperature display turns dark.
- If you only wish to switch off the **fridge/BioFresh** section (the freezer stays switched on, useful if going on holiday for example) then press the **on/off switch ⑨ so that the temperature display on the fridge ⑥ and the interior light goes off. The temperature display on the freezer ⑤ must remain lit.**

### Setting the temperature

The appliance is set as standard for normal operation; in the fridge section we recommend +5°C, and for the freezer -18°C.

**Reducing the temperature/colder:** Press the relevant **Down**-button, on the left for the fridge: ⑧, on the right for the freezer: ④.

**Increase temperature/warmer:** Press the relevant **Up**-button.

- While you are making the adjustment the **set value** display flashes.
- The first time you press the temperature setting button, the current **most recent setting value (= nominal value)** appears on the display.
- If you press again briefly, the set value changes in 1°C steps, and if you hold it down, will continue to change.
- About 5 seconds after the final touch of the button, the electronics automatically change the setting, and the **actual** freezer or fridge temperature (= **actual value**) is displayed.

The temperature can be adjusted in the

- **fridge section:** from 11 °C to 2 °C, in the
- **freezer section:** from -16 °C to -26 °C.

It depends on where the appliance is located as to whether the lowest temperature will be reached, in high ambient temperatures, it may not be possible to achieve the lowest temperature.

### Temperature display

In normal operation:

- the **average temperature inside the fridge is ⑥** and
- the **warmest temperature of frozen food ⑤** is displayed.

**The display flashes, if you**

- change the temperature setting, or
- if the temperature rises by several degrees, indicating a loss of cooling capacity, for example warm air can temporarily raise the temperature when you open the door to store fresh "warm"

food, or to remove or sort out frozen items. Once you have finished placing items in the fridge, or sorting out the items, the electronics automatically adjust the temperature to the most recent setting. A short-term increase in temperature will not affect the frozen food.

- If the display is showing “F 0” to “F 5” the appliance has a fault. Please contact your customer services, and inform them about the indication. This will make it possible to provide fast and accurate service.

### Alarm - audible signal

The audible warning signal will help you to protect your stored frozen food, and to save energy.

- **The audible signal can be shut off** by pressing the alarm off button ①,
  - automatically once it reaches a temperature sufficient for storing the food safely, or
  - when the door is closed.

### Door alarm (for fridge section and freezer section)

- This always sounds if the door is kept open for longer than 60 seconds. The warning signal switch off function is effective while the door is open. Once the door is closed, the alarm function automatically resets itself.

### Temperature alarm (for freezer section)

- This always sounds if the freezer temperature is not cold enough (it depends on the temperature setting).
- **The temperature display flashes at the same time.**

This can happen when

- warm, fresh food has been put into the freezer,
- too much warm air gets in while you are sorting out the freezer or removing items.

The temperature display **continues to flash** until the alarm situation has ended. It then switches from flashing to continuous light. The audible signal is then automatically reset **ready for operation**.

### Fan ①

For cooling by circulated air. If necessary you can use the fan switch if you have large amounts of food to cool down quickly, and you want a relatively even temperature throughout the fridge compartment on all the shelves. An intensive circulation of air will stop different areas of temperature from forming. All the food is cooled evenly. We recommend using the fan when the room temperature is hot (from approximately 30°C) or when the air humidity is high, for example on hot summer days.

Note: To save energy, the fan automatically switches off when the door is opened. Power consumption rises when the fan is switched on.

### SuperCool

You can use the SuperCool button to switch the refrigerator to its maximum cooling power.

We particularly recommend that when freezing **large** quantities of food, drinks, freshly baked cakes or meals, they should be frozen as quickly as possible.

- **Switching on:** Briefly press the SuperCool button ① so that it lights.

The cooling temperature goes down to the lowest value.

**Note:** “SuperCool” uses slightly more energy. However after about 6 hours, the electronics system **automatically** switches back to normal power-saving operation.

If necessary you can also switch on the “SuperCool” function earlier.

- **Switching off:** press again briefly, until the button light goes out.

### Power failure/“FrostControl” display

If a “nA”, symbol appears in the display, this means that:

The freezing temperature **has** risen too **high** due to a power failure, or a power cut during the last few hours or days.



- If, while the nA-symbol is showing, you press the alarm off button ① the **warmest** temperature that occurred during the power cut is displayed.

Depending on how warm the temperature became, even to the point of defrosting, you should check the quality of the food, and decide how to deal with it!

- This “warmest temperature” displays for approximately one minute. After that the electronics system displays the current actual freezing temperature. If you repeatedly press the alarm off button, you can delete the “warmest temperature” display. When the power cut ends, the appliance continues to operate at the most recent temperature setting.

### Additional functions

You can use the setting mode to set the **child lock**, and change **the brilliance of the displays\***

#### Activating the setting mode:

- Press the SuperFrost button for about 5 seconds - the SuperFrost button flashes - the display indicates **c** for child lock.

**Note:** The value you are about to alter is flashing.

- Press the Up/Down button to select the function you want:

**c** = child lock,  
**h** = brilliance or

- Now briefly press the SuperFrost button to select/confirm the function:

- For **c = child lock** press

the Up/Down button **c1 = child lock to switch on**

**c0 = child lock to switch off** and confirm with the SuperFrost button.

When the symbol ⑦ is lit, the child lock is active.

- For **h = brilliance** select the

Up/Down button **h1 = minimum** to

**h5 = maximum** brilliance select and confirm with the SuperFrost button.



#### Quitting the setting mode:

- Press the On/Off button to quit the setting mode; the electronics setting switches after a period of 2 minutes.
- Normal regulated operation is active again.

## Net@Home

Depending on the model and the options, the appliance can also be equipped with an additional connection for a retrofitted Net@Home module. You can connect either a TeleSafe module or a House-bus Module. You can obtain these modules from your dealer.

For technical warranty reasons, the module must be fitted only by customer services.

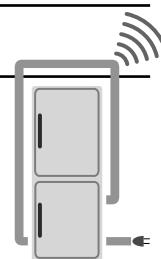

You will find further information at our Internet site [www.liebherr.com](http://www.liebherr.com)

## Fridge section

### Organising food storage

The warmest part of the fridge is the top at the front and in the door

### Information about keeping food cool

- Store food in such a way that the air can circulate freely, i.e. do not pack too tightly. Do **not** cover the ventilation grilles\* on the rear wall - this is important for the cooling capacity!
- Always keep food that can give off or take on slight smells or tastes, such as liquids, in airtight containers, or keep them covered.

### Changing the layout

- You can adjust the **preserves rack**\* and remove all the door racks for cleaning. Push up the rack, pull forwards to remove, and reinstall in reverse order.

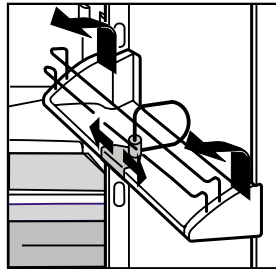

- By shifting the **bottle and preserves rack** you can secure bottles from tipping out when you open and close the door, to do this make sure you always use the plastic retainer! You can move the retainer for cleaning: pull the lower edge of the retainer forwards, and disengage it from the rack.

- You can adjust the **shelves/glass plates**\* to suit the height of the food containers.
  - Lift up the glass tray pull out the recesses above the tray and push back in a higher or lower position.
  - An end stop prevents the glass plates\* from being pulled out inadvertently.

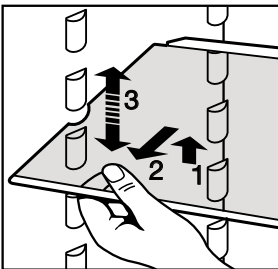

- Use the front surface of the fridge base only for short term food storage **for example if you are moving things around, or sorting out the fridge. This makes it easier to handle. However do not** allow items to stand, otherwise they will be pushed back, or tip over when the door is closed.

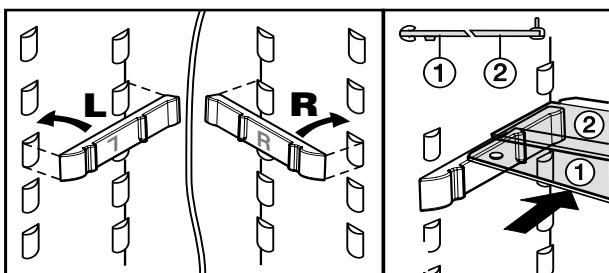

- The **half glass plates** provide space for tall containers: Insert the rails supplied onto the shelf notches at the desired height on the left and right, checking that the right (R) and left (L) sides are appropriately inserted! Slide in the glass plates ① / ② . The glass plate ② with the stopper edge must be at the back!

## Freezer section

### SuperFrost

**Fresh** food must be deep frozen as quickly as possible and frozen food already in storage must have a "cold reserve". This allows the SuperFrost device to work. It is the best way of maintaining the nutrition, appearance and taste of frozen food.

- Only the maximum number of kilograms of fresh food as stated on the type plate under "freezing capacity ...kg/24h" should be frozen in a 24 hour period, Fig. **A3**, item ④ . This maximum amount for freezing depends on the model and climate class.

### Freezing with SuperFrost

- Briefly press the SuperFrost button ② so that the LED lights up. The freezing temperature is reduced, and the appliance is operating at the maximum freezing capacity.
- If the amount you are freezing is fairly small, wait for approximately 6 hours. This is usually enough. If you are freezing the **maximum** quantity, see the type plate under freezing capacity, you should wait for approximately 24 hours.
- Then place the fresh food inside, preferably in the upper drawers.
- SuperFrost switches off **automatically**. Depending on the quantity stored, as required, at the earliest after 30 hours, and maximum after 60 hours. Freezing is finished when the **SuperFrost LED has gone out** - the appliance is now operating in normal energy-saving mode.

**Note:** Do **not** switch on SuperFrost:

- if you are storing items that are already frozen,
- if you are storing up to 2 kg of fresh food every day.

### Freezing and storage information

- **The following are suitable for freezing:** Meat, game, poultry, fresh fish, vegetables, fruit, dairy products, bread, cakes, prepared meals.
- **The following are not suitable:** lettuce, radishes, grapes, whole apples and pears, fatty meat.
- **Suitable packing items are** standard freezer bags, re-usable plastic, metal and aluminium containers.
- Do not allow food about to be frozen to touch already frozen items. Make sure the packs are dry to prevent them from freezing together.
- Always write the date and contents on the packs, and do not store for longer than the recommended storage period in order to maintain the quality.
- Always pack food that you are freezing yourself into portions to suit your household. Do not exceed the following quantities in each pack, to ensure that the contents will freeze quickly to the core:
  - Fruit, vegetables, up to 1 kg,
  - Meat, up to 2.5 kg.
- After washing, blanch portions of **vegetables** (2-3 minutes in boiling water, remove and plunge into cold water to cool. If you use a steamer or microwave to blanch, please follow the instructions for the appliance concerned).
- Do not salt or season fresh food and blanched vegetables before freezing. Other foods should be only slightly salted and seasoned. The strength of the taste of some seasonings can change.
- Do not freeze drinks bottles and cans containing carbon dioxide. They might explode. If you wish to cool drinks very quickly, always remove them from the freezer within one hour at the latest!

- **For storage:** Each drawer or storage shelf can be loaded with **max. 25 kg** of frozen food.
- Always store the same type of food together, this means you do not need to keep the door open for an unnecessarily long time, and saves energy.
- Do not exceed stated storage periods.
- **To defrost** only remove the amount you need for now. You should use defrosted food to make a meal as quickly as possible.  
You can defrost the frozen food:
  - in the oven/fan oven
  - in the microwave
  - at room temperature
  - in the fridge, the coldness of the item is used to keep the food cool.

### The Information System\*

Prepared meals		2-6		Sausage
Ice cream				Bread
Fish		4-8		Mushrooms
Pork				Game
Vegetables		6-12		Poultry
Fruit				Beef/veal

Frozen food should be consumed within the recommended storage periods.

The figures between the symbols shows the storage period in months for each of several types of frozen food.

The storage periods shown here are guidelines for freshly frozen food. It depends on the quality of the food and how it has been handled prior to freezing as to whether the upper or lower limit should apply. For fatty food, the lower value must always apply.

### The freezer tray\*

allows you to freeze berries, herbs, vegetables and other small items separately. It stops them from freezing together. The item keeps its shape to a great degree, and it is then easier to divide them into portions.

- Spread the frozen food loosely onto the freezer tray
- Allow the items to freeze through for 10 to 12 hours, then put them into a freezer bag or container, and store in a drawer.
- To defrost, spread them out again alongside one another.

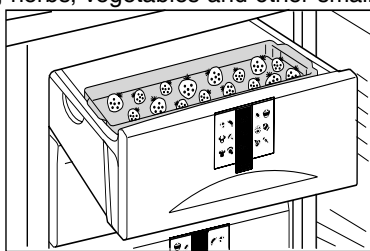

### The cold accumulators\*

In the event of a power failure these prevent the temperature from rising too quickly - the quality of the food is better retained.

You can freeze and store the cold accumulators either on the freezer tray or in the freezer compartment lid\*.

#### ● Inserting the cold accumulators:

Remove the topmost drawer. Insert the cold accumulators into the top rear of the freezer section roof and engage in a forward direction.

#### ● Removing the cold accumulators:

Remove the upper drawer. Grasp the cold accumulator at the side and push downwards.

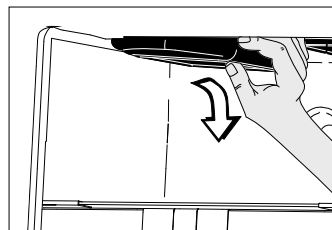
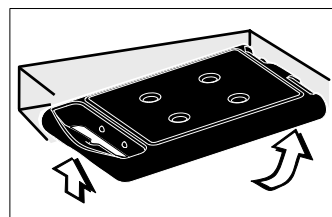

GB

### VarioSpace\*

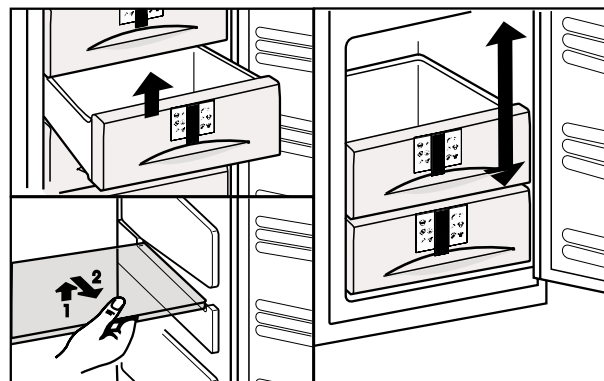

- If you remove one of the drawers and the shelf, you can gain 2 drawers' worth of space for larger items. For example you can store poultry, large joints of meat and game without having to split them, so you can keep the joint "whole". You can store cakes and packs of ice.
- **Take a drawer out as far as the stop** and lift forwards and upwards.
- **Lift up the storage surface**, forwards and upwards .
- To replace, proceed in reverse order: proceed in reverse order simply push in the shelf as far as the stop.
- **Appliances with NoFrost\*:** Always leave the bottom drawer inside the appliance.
- Do **not** cover the vents on the rear wall when you take out the upper drawer; this is important for the appliance to function properly

## Defrosting, cleaning

### Information about defrosting

The NoFrost system\* automatically defrosts the appliance.

The moisture created drops down to the evaporator, where it is periodically defrosted and evaporated.

The automatic defrost function ensures that the freezer compartment is always frost-free, and you save time and work because there is no need to manually defrost the appliance.



### Freezer compartment

Appliances without a NoFrost system can form a layer of frost and ice after extended periods of use, depending on how often the door is opened, and the amount of "warm" food placed inside. This is completely normal. However a thick layer of ice will increase power consumption. For this reason you should defrost the appliance regularly: Do not use an electric heater or steam cleaner, defrost spray, open flames or metal objects to remove the ice. You can cause injury to yourself and damage the appliance!

One day before you are going to defrost the freezer, switch it to "SuperFrost", to ensure that the food obtains a "cold boost".

To defrost: Remove the plug or press the freezer on/off switch, so that the temperature display goes out. If the display does not go out, the child lock is on.

Leave the drawers and the freezer door open while you are defrosting. Soak up any defrost water with a sponge or cloth.

### Cleaning

● **Before cleaning you should, in principle, put the appliance out of operation. Remove the mains plug or remove the fuses or trip the fuse switch.**

● Manually wash the inside and the components with luke warm water, and a little washing-up liquid. Do not use a steam cleaner - you can injure yourself and damage the appliance!

● We recommend using a soft cloth and an all-purpose detergent with a neutral pH value.

- Do not use abrasive scourers, do not use undiluted detergent and never use cleaning agents or chemical solutions containing sand, chloride or acid.

● Make sure that the cleaning water does not get into the drain, ventilation grille or the electric parts. Rub the appliance dry.

- Do not damage or remove the type plate inside the appliance - it is important for customer services.

● The butter box\* can be washed in the dishwasher, the shelves, glass shelf and other components must be hand-washed.

● Remove the shelves as shown in the illustration:

- Lift the glass shelf, pull out the recesses above the supports, lower to one side, and remove at an incline.

- Always insert the shelf surfaces with the stopper edge to the rear and pointing upwards, otherwise food may freeze to the back wall.

● If you **want to remove** the top door rack (butter and cheese compartment), always lift it out together with its lid\*! Then carefully push one side of the rack outwards, until the lid pin is disengaged and the lid can be removed to one side.

- You can dismantle the racks and door racks for cleaning - you can pull the strips and side components away from the glass tray.

- Remove the protective film from all the decorative strips, fig.

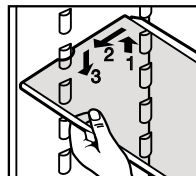
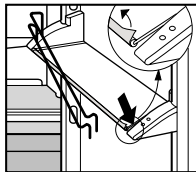

● You should regularly clean the **drain opening** on the rear wall behind the vegetable drawer. **If necessary clean it out with a soft thin object, such as a cotton bud or similar.**

● Then reconnect the appliance, or switch it back on.

If the appliance **is going to be out of use for an extended period of time** empty it of all its contents, remove the plug, and clean it as described above and leave the appliance door open to prevent odours from forming..

## Faults - problems?

If a fault should occur while it is in operation, please check whether the fault might have been caused by an operating error, because should this be the case, then you will be charged for the cost of any repairs during the guarantee period.

You can fix the following faults yourself by checking for the likely cause:

**fault** - possible cause and remedy  
**The appliance is not working, the display is not lit**

- Has the appliance been switched on properly?
- Is the plug inserted correctly in the wall socket?
- Is the fuse in the plug working correctly?

**The interior light does not go on**

- Has the refrigerator section been switched on?
- Has the door been open for longer than 15 minutes??
- The bulb is faulty.

### Mains voltage



**Caution!** To prevent injury and material damage, any repairs and replacements to the interior LED lights must be carried out only by customer services.



**Careful - class 1M laser beam. If the cover is open, do not look directly inside with an optical instrument. The noise is too loud**

- Is the appliance firmly positioned on the floor, are nearby kitchen units or objects vibrating as a result?  
Make sure that bottles and containers are not touching.

- It is normal for: **trickling**, bubbling or splashing sounds to occur; these are from the coolant flowing through the coolant circuit.

A slight **clicking will occur**, this always happen when the fridge motor switches itself on and off automatically.

**A humming noise from the motor.** This is a little louder for a very short time when the unit switches on. When SuperFrost is switched on, when food has been recently stored or if the door is open for a long period, the cooling capacity automatically increases. A deep humming noise is caused by **the noise of air flowing** through the fan.

**The alarm has sounded, the temperature is not low enough**

- Is it possible that you have stored too much fresh food **without** switching on SuperFrost? (see section on "SuperFrost")
- Is the door properly shut?
- Is there sufficient ventilation?  
Ensure that the vents are not blocked.
- Is the ambient temperature too high? (see section on "Conditions")



- Have you opened the appliance too frequently and for too long?
- Wait to see if the appliance goes back to the required temperature by itself.

#### **nH** appears on the display

- A power failure or power cut has occurred, proceed as explained in the section entitled "Power cut/FrostControl display"

#### The compressor runs for a long time

- This is completely normal and necessary on energy-saving models. The speed regulated\* compressor switches to a lower speed when it requires a lower cooling capacity. Although this means that the running time increases, to almost permanent, in fact it is saving energy.

## Customer services and type plate



If none of the above causes is present, and you cannot fix the faulty yourself, or if the temperature display is showing "F0" to "F5" this means that: there is a fault. You should contact your nearest customer services point (see directory enclosed). Tell them of the fault message **on your display** and also the

### Appliance designation ①

### Index ② ,

### Serial no.. ③

of the type plate. This will make it possible to provide fast and accurate service. The type plate is located inside the appliance to the left.

Keep the appliance closed until customer services can come to avoid any further loss of cold.

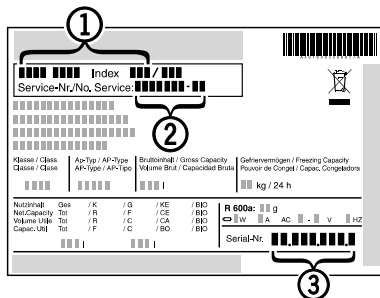

## Installation information

- The appliance can also be installed in a **fitted kitchen**. If this is the case you first need to fit the kitchen unit door and the niche in which the appliance will be positioned. These are no longer required, because the fitted unit door is fitted to the door of the appliance.

GB

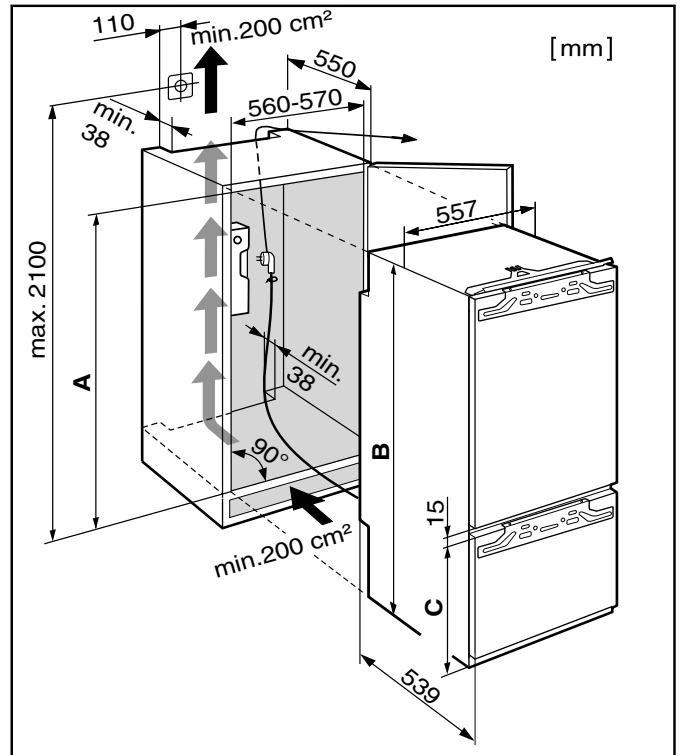

- Check the dimensions:

	A	B	C
ICN 30	1772-1778	1769,5	695
IC 29	1574-1590	1574,5	549

- Use a spirit level to ensure that the niche cupboard is level. If necessary, even it out by using base cauls. The base and walls of the kitchen unit must be at right angles to one another.
- The fridge/freezer must be installed only inside solid kitchen fittings.
- It is essential that the ventilation cross-sections are maintained:
  - The ventilation shaft at the rear of the unit must be at least 38 mm deep.
  - A minimum of 200 cm<sup>2</sup> is necessary for the ventilation cross-sections at the base of the unit and the surrounding unit. In general the following applies: the larger the ventilation cross section, the more energy the appliance will be able to save.

### Before starting the installation:

- Remove the mains cable holder from the back of the appliance.
- Use a cord to lay the mains cable.

You will also need the following tool for the installation: cordless Torx screwdriver ®15, 20, 25, hexagon spanner 13.

## Replacing the door stop

If necessary you can change the door stop, please see further instructions from "installation information" onwards

- To make it easy to fit, push the appliance three-quarters of the way into the niche. Open the door.

- Dismantle the closing damper :

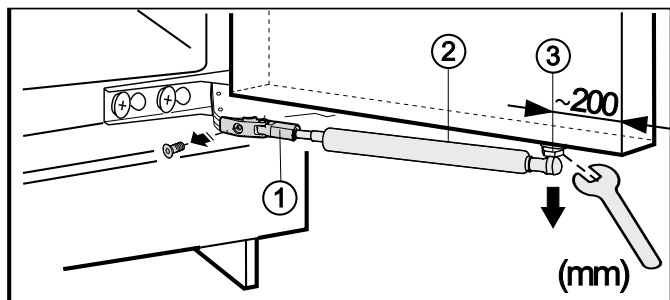

**Caution** when dismantled the closing damper retracts!

- Unscrew the holder ①
- Unscrew the ball pins ③ , **together** with the closing damper ② , from the door, and place to one side.

**Caution:** Do **not** pull the closing damper from the ball pins. It could become damaged



- Pull the cover components ⑤ , ⑥ , ⑦ and ⑧ forwards and upwards with the aid of a slotted screwdriver.
- Simply loosen the fastening screws ⑨ on the body of the appliance at the top and bottom .
- Push the doors outwards and take them off their hinges.

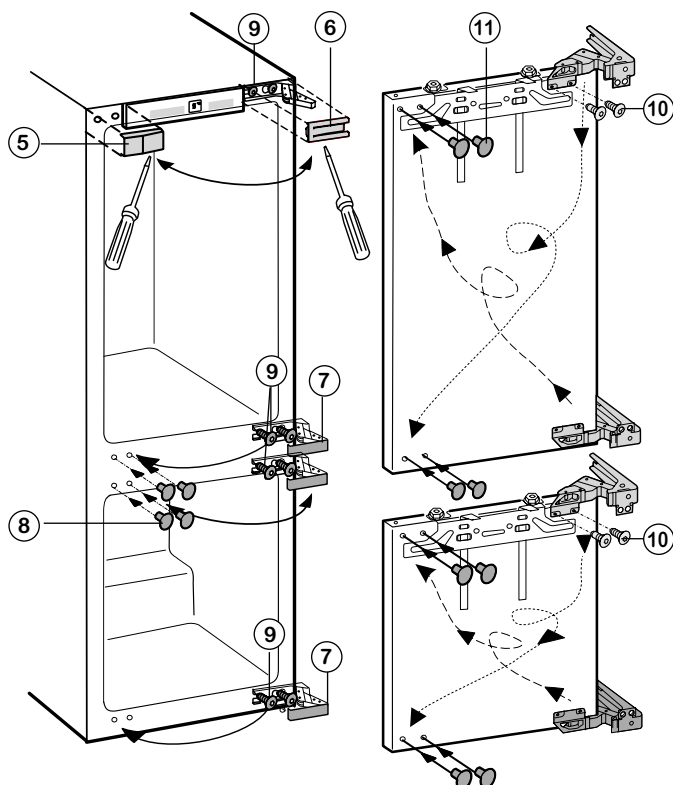

- Set the fastening screws ⑨ on the opposite side, and screw in briefly.
- Screw out the door fastening screws ⑩ and place the hinges diagonally.

**Caution** Do **not** allow the hinges to fold inwards - an injury could be caused!



- Use a cordless screwdriver - to fasten the screws. The screws ⑩ are self-piercing.
- Use the plugs to seal ⑪ the former fastening holes.
- Fit the doors of the appliance onto the prefitted screws ⑨ and fasten the screws.

Refit the closing damper ②\* :

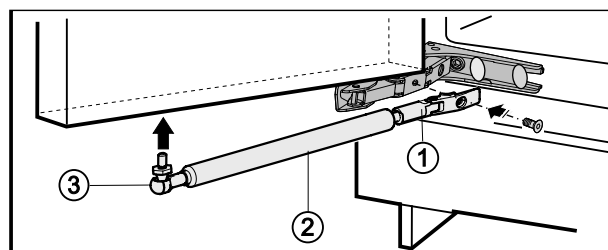

- Screw ① the holder back on
- Screw the ball pins ③ **together** with the closing damper ② into the new fastener holes.
- Refit all the cover components .

## Overview of all the components required for installation, and their position on the appliance

## Fixing and assembly

GB

⑩ 8x 	⑳ 1x 		
㉓ 2x 	㉗ 1x 	㉒ 1x 	
㉔ 2x 	㉙ 1x 		
㉘ Torx® 25 2x M5 x 22 	㉚ Torx® 15 24x 4 x 14 	㉛ Torx® 15 10x 4 x 19 	1x 
㉜ 2x 	㉞ 4x 	㉝ 4x Torx® 20 	㉟ 4x 
㉟ 2x 	㉞ 19 mm 1x SW 5 	㉟ 1x 	7 10 
㉜ 2x 	㉝ 2x Torx® 20 	㉚ 4x Torx® 15 	㉟ 2x 
★	2x	4x 4x 	2x 

All the fastening elements are supplied with the appliance.

- Fit the shim ⑩ at the centre of the appliance: Push into the rack and hook into the key holes.
- Screw the angle bracket ㉜ using the hexagonal screw ㉝ into the predrilled holes on the appliance door.
- Push the appliance three quarters of the way into the niche.
- Pay attention to the thickness of the unit wall:

**If the unit walls are 16 mm thick** = the niche should be 568 mm wide:

- Glue the cover strip ㉒ on the grip side and flush with the side wall of the appliance: Remove the protective film and the rubber gasket; if necessary cut the rubber gasket to suit the height of the niche.
- Clip spacers ㉓ to each of the upper and ㉔ lower hinges.
- Push the appliance into the niche until the spacers touch the back of the unit.

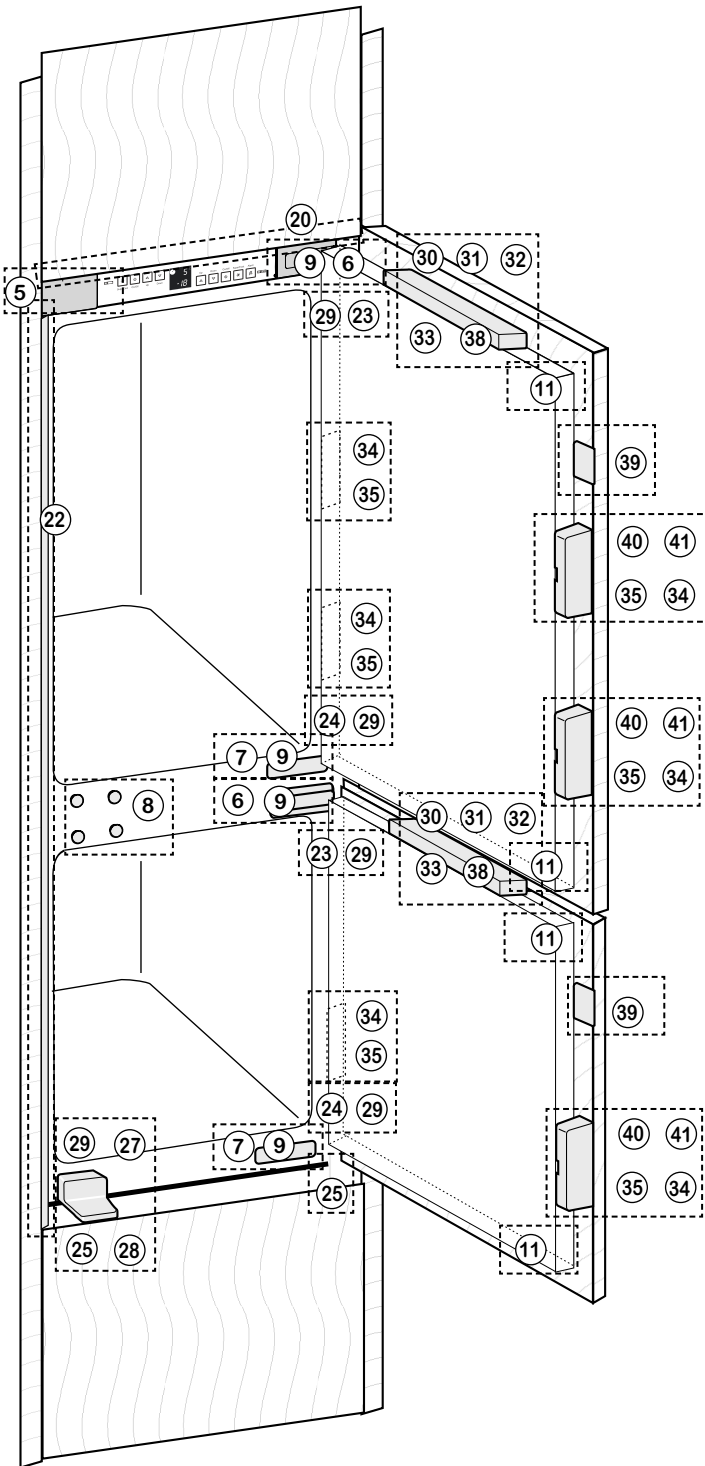
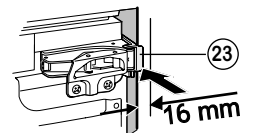
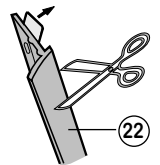
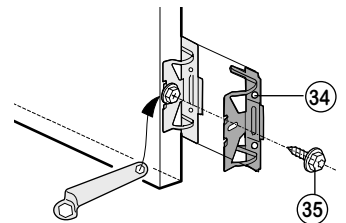
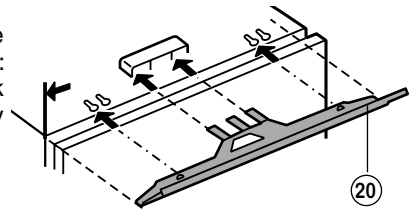

**If the unit walls are 19 mm thick= the niche should be 562 mm wide:**

- Push the appliance into the niche until the front edges of the hinges are flush with the side walls of the unit, on units with door stopper components (burls, sealing lips etc.) please pay attention to the dimensions of these! Allow the hinges to protrude by the amount of their dimension. Push the appliance against the unit wall, hinge-side facing.

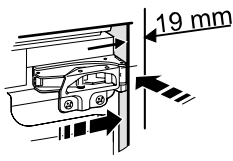

- Use the adjusting feet (25) to align the appliance, using the wrench supplied (26) so that it is positioned upright. Make sure the body of the appliance is parallel with the front edges of the sides of the unit.
- Screw the plastic bracket (27) using M5 screws (28) on the handle side of the appliance.
- Align the bottom of the plastic bracket (27) flush with the front edge of the floor of the unit. If there are door stopper elements (burls, sealing lips etc.) take account of the dimensions of these and align them to be parallel with the front edge of the hinge.

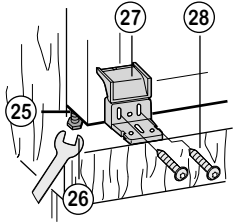

- Screw the appliance into the niche .
- Use long chipboard screws to screw through the (29) hinge lugs at the top and the bottom.
- Use a long screw (29) to prefit the central slotted hole on the plastic bracket (27) . Fold back the cover on the plastic bracket, and close the door of the appliance.

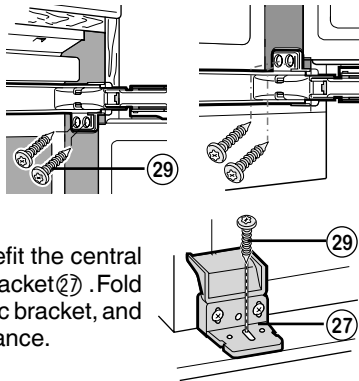

**Fitting the kitchen unit door**

**Note: You need the assembly devices (30) for both doors. You therefore need to fit the unit doors one after another.**

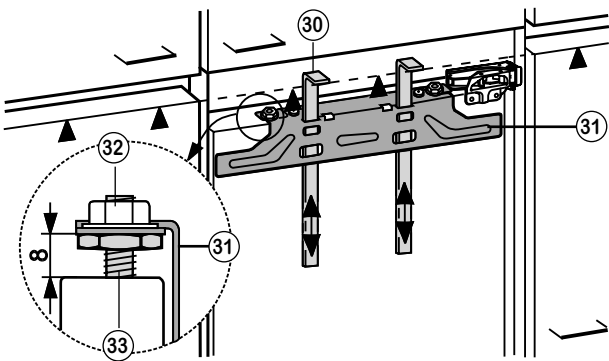

- Check the presetting of 8 mm (distance between appliance door and lower edge of traverse).
- Push the assembly devices (30) to the height of the unit door, lower edge of the stop ▲ on the assembly device = upper edge of the door to be fitted.

- Fit the fastener traverse (31) to the unit door:
- To do this screw off the traverse above the lock nuts (32) .
- Use the assembly devices (30) to suspend the traverse onto the inside of the unit door align it to the centre (draw a short centre line onto the unit door, bring the tip of the arrow on to it, the distances to the outer edge must be the same to the right and to the left).

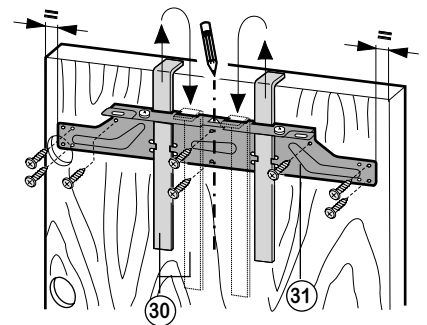

- Fasten the fastening traverse (31) in the centre:
- use at least 6 screws for chipboard doors,
- use 4 screws at the edges on cassette doors.
- Pull the assembly devices (30) upwards and push them, at an angle, into the receiving apertures.

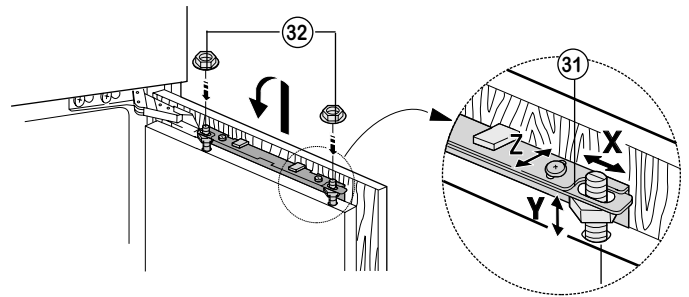

- Hinge the unit door onto the appliance door/adjusting pins (33) , loosely screw on the lock nuts (32) onto the adjusting bolts. Close the door.
- Check the distance of the door against the surrounding unit doors.
- Align the unit door to be flush with the surrounding unit doors: Even the sides X by pushing, and the height Y and lateral inclination, using the adjusting bolts (33) - with a screw driver.
- Tighten the lock nuts (32) .

- Screw the appliance door (34) onto the unit door with the fixing bracket (41):
- Make sure the two metal edges are flush, symbol //. Then predrill the fastening holes (if necessary use a bradawl to punch holes) and screw firmly.

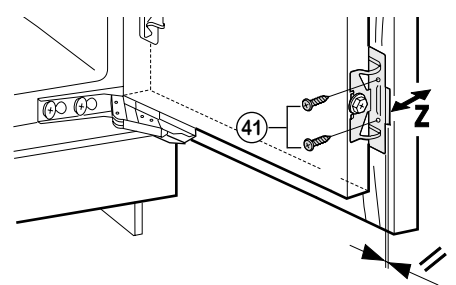

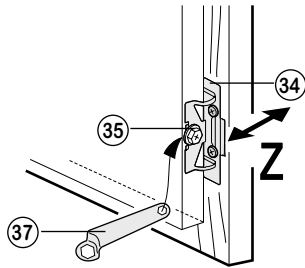
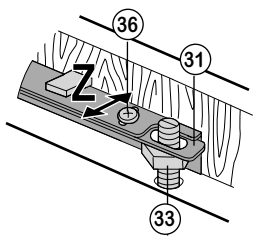

- Align the depth of the unit door **Z** :
  - top: loosen screws 36
  - at the bottom: loosen the hexagonal screws 35 with the ring spanner supplied 37 and adjust the door.
- Allow an air gap of approximately 2 mm between the unit door and the body of the unit. Do not allow any burrs or sealing lips to touch - this is important for correct function!

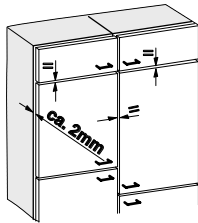

- For large unit doors, fit a third pair of fastener brackets 34. To do this use the predrilled holes in the handle area of the appliance door.

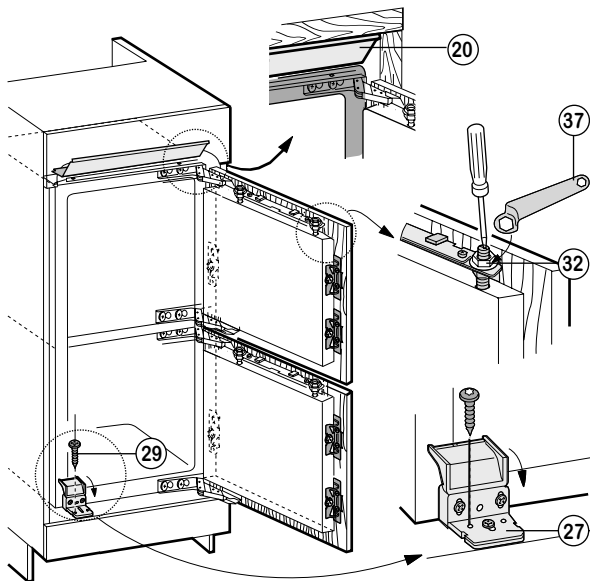
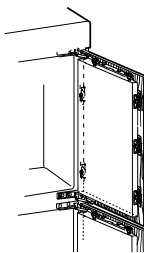

- Check that the doors are correctly seated and adjust if necessary. Tighten all screws.
  - Tighten the lock nuts 32 with the ring spanner 37 hold the adjusting bolts 33 with a screwdriver as you do so.
- If necessary, adjust the shim 20 by pushing it parallel to the floor of the unit. It must not protrude.
- Fix the appliance underneath with the plastic bracket 27 using a second screw 29 to fasten it into the round hole.

- Fit all the covers:
  - Position the upper covers 38 and engage them.
  - Position the side covers 39 as far as the stop, then press the cover until it engages with an audible click.
  - Push the cover 40 at the side, using a screw driver, to pull the cover forward so that it engages correctly.

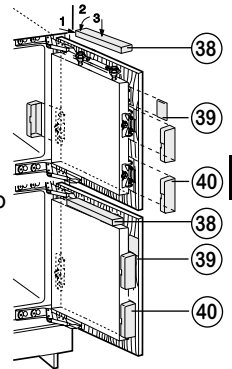

- You can now adjust the end stop spring on the doors. Make the setting as required with the allen key 5 supplied:
  - turn clockwise = stronger spring force,
  - turn counter-clockwise = weaker spring force (condition in which supplied).

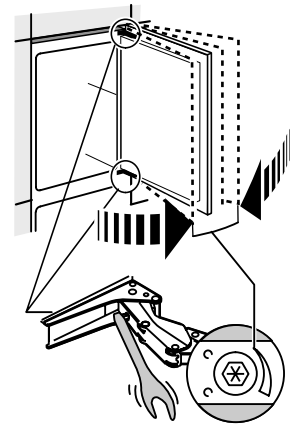

- Place the rest of the covers on the hinges

The manufacturer is constantly developing and enhancing all types and models. Please therefore understand that we reserve the right to make changes to the shape, options and technology used.

LIEBHERR Hausgeräte  
Ochsenhausen GmbH  
Memmingerstrasse 77-79  
D-88416 Ochsenhausen

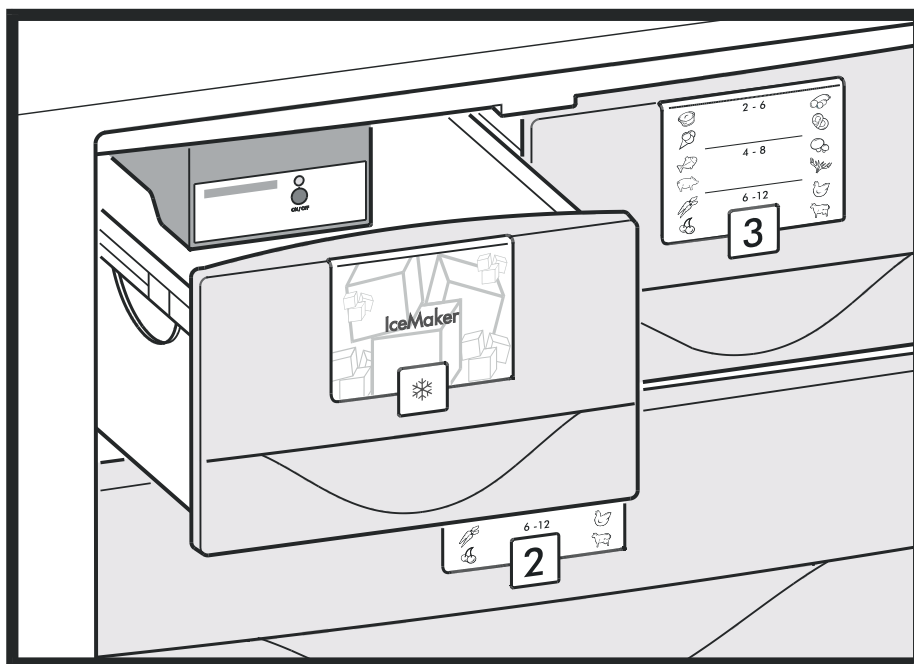

The ice maker is fitted in the freezer compartment of the combined refrigerator-freezer. It must be connected to the **mains water supply** to work. The descriptions below only relate to the ice maker and the water connection to a solenoid valve. All the instructions and details for the appliance as a whole are set out in the enclosed operating instructions for the combined refrigerator-freezer.

The floor on which the appliance stands should be horizontal and level. To compensate for any unevenness, adjust the height of the feet with the open-ended wrench supplied. **The combined refrigerator-freezer must stand level.**

### Safety instructions and warnings

- Do not make the water connection whilst the combined refrigerator-freezer is connected to the electricity supply.
- **The connection to the mains water supply may only be made by a trained plumber.**
- **The water quality must comply with the drinking water directives of the country in which the appliance is used.**
- The ice maker is designed exclusively to make ice cubes in quantities required by a household and may only be operated with water suitable for this purpose.
- All repairs and work on the ice maker may only be carried out by customer service personnel or other trained personnel.
- **The first three batches of ice must not be consumed or used. This applies both to using the appliance for the first time and also to using it after it has not been used for a lengthy period of time. This ensures that the water supply is purged.**
- **The manufacturer cannot accept liability for damage caused by a faulty connection to the mains water supply.**

### Instructions for trained personnel

#### Position of the water connection

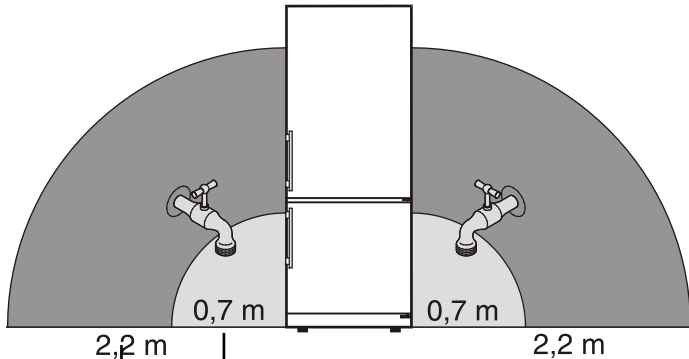

Position of the water connection if a 1.5 m hose is used. This hose is supplied with the appliance as standard.

Position of the water connection if a 3 m hose is used. This hose is available from our customer service department.

### Instructions for trained personnel

#### Connection to the water supply

Please read the first three points of the safety instructions and warnings before connecting the appliance to the mains water supply.

The **water pressure** must be between **1,5 and 6 bar**. The water supply to the appliance must be through a cold water pipe that can withstand the operating pressure and complies with the hygiene regulations. For this, use the stainless steel hose supplied (length 1.5 m).

**An extension hose of either 1.5 m or 3 m is available from the customer service department which must be assembled by a technician.**

A shut-off valve must be installed between the hose line and the house mains supply so that the water supply can be stopped if necessary.

Connect the straight section of the supplied stainless steel hose to the shut-off valve. There is a screen and seal in the connector.

Connect the angled section of the stainless steel hose to the solenoid valve. The water connection to the appliance is via the solenoid valve on the rear of the appliance. The connection dimension is R 3/4.

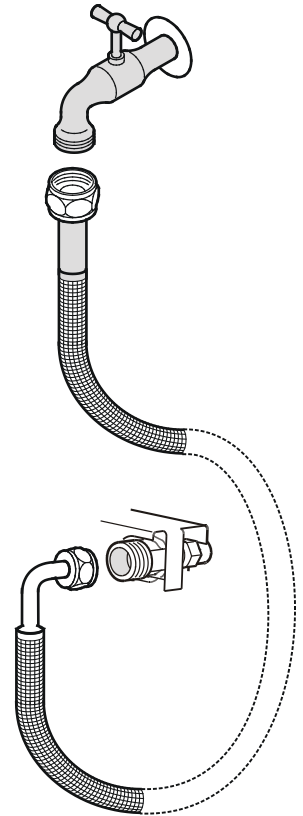

**Before the appliance is used for the first time the system must be bled of any air by a competent person (i.e. Plumber)**

1. Open the shut-off valve for the water supply and check the entire water system for leaks.
2. Insert the mains plug for the combined refrigerator-freezer into the socket.
3. Move the combined refrigerator-freezer into its intended final position. **Ensure that the water supply pipe is not damaged or kinked as you do this.**



**All equipment and devices used to supply the water to the appliance must comply with the current regulations of the country concerned.**



## To start the ice maker

The ice maker will only work if the combined refrigerator-freezer is connected to the electricity supply. It will only make ice cubes if the freezer compartment is operating.

The ice maker is in the top left drawer in the freezer compartment of the combined refrigerator-freezer. You can identify this drawer by its labelling "Ice maker".

### To switch on

- Pull out the drawer.
- Press the "ON/OFF" button so that the control lamp comes on.
- Close the drawer.

**Note:** The ice maker can only make ice cubes if the drawer is completely closed.

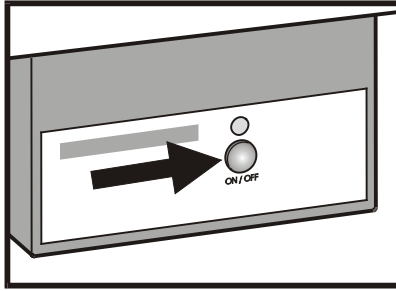

### To switch off

If you do not need any ice cubes the ice maker can be switched off independently of the freezer compartment.

- Press the "ON/OFF" button for approx. 1 second so that the control lamp goes out.

**Note:** If the ice maker is switched off, the empty drawer can also be used to freeze and store food.

## To make ice cubes

After you start the ice maker for the first time it may take up to 24 hours before the first ice cubes are ready.

**Please note that the first three batches of ice must not be consumed or used.**

The production capacity depends on the temperature inside the freezer compartment. The lower the temperature, the more ice can be produced over a period of time.

The ice cubes fall out of the ice maker into the drawer. When the ice reaches a certain level in the drawer, the appliance stops producing ice automatically.

If you require a large quantity of ice you can swap the drawer to the right with the complete "Ice maker" drawer. When you close the drawer the ice maker will immediately start production.

## Cleaning the ice-cube tray

The ice-cube tray can be cleaned. Use the following method.

- **The IceMaker must be switched on.**
- Remove any ice cubes from the drawer.
- Hold the "ON/OFF" button for 10 seconds (after 1 second the IceMaker will switch off - the LED will go out).
- After you have held the "ON/OFF" button for 10 seconds the LED will start to flash for 60 seconds.
- Insert the drawer during these 60 seconds. Then the ice-cube tray will move into an angled position.
- Remove the drawer - the ice-cube tray can now be cleaned. The best way of doing this is with warm water and a little washing-up liquid.
- Press the "ON/OFF" button and close the drawer. The IceMaker will then immediately restart with its production of ice cubes.

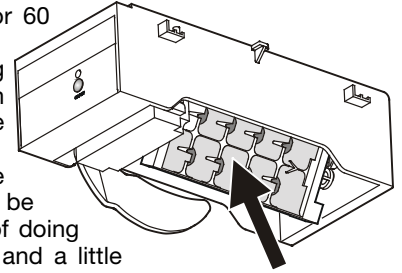

This procedure should also be completed if you switch off the IceMaker. This ensures that no water or ice will be left in the ice-cube tray.

## Malfunction

If a malfunction occurs during operation, check whether it is due to an operating error.

**You may be able to rectify the following faults yourself:**

- **The ice maker cannot be switched on**
  - Is the combined refrigerator-freezer connected to the mains electricity supply?
- **The ice maker is not making any ice**
  - Is the ice maker switched on?
  - Is the water supply line open?
  - Is the "Ice maker" drawer closed properly?

If you are unable to rectify the fault yourself or if the control lamp above the "ON/OFF" button flashes, contact our customer service department. Refer to the section headed "Troubleshooting" in the operating instructions for the combined refrigerator-freezer for details of the type plate data you will be required to quote.

## Free Manuals Download Website

<http://myh66.com>

<http://usermanuals.us>

<http://www.somanuals.com>

<http://www.4manuals.cc>

<http://www.manual-lib.com>

<http://www.404manual.com>

<http://www.luxmanual.com>

<http://aubethermostatmanual.com>

Golf course search by state

<http://golfingnear.com>

Email search by domain

<http://emailbydomain.com>

Auto manuals search

<http://auto.somanuals.com>

TV manuals search

<http://tv.somanuals.com>