

Classic Series Cross-Trainer Model CL5XH

ASSEMBLY INSTRUCTIONS



LifeFitness

Congratulations...

and welcome to the world of

LifeFitness

The following Parts List and the step-by-step assembly procedures have been assembled to make the set-up of the Cross-Trainer as quick and easy as possible.

Please take special note of the following important points prior to choosing a location and beginning assembly of the Cross-Trainer.

IMPORTANT SAFETY INSTRUCTIONS!

- **DO NOT** LOCATE THE CROSS-TRAINER OUTDOORS, NEAR SWIMMING POOLS, OR IN AREAS OF HIGH HUMIDITY.
 - **DO NOT** OPERATE YOUR CROSS-TRAINER IF IT HAS BEEN DROPPED, DAMAGED, OR EVEN PARTIALLY IMMERSSED IN WATER. IF THIS OCCURS, CONTACT LIFE FITNESS CUSTOMER SUPPORT SERVICES AT THE NUMBER IN THE OPERATION MANUAL.
 - **DO NOT** LOCATE THE CROSS-TRAINER ANY CLOSER THAN 30 INCHES (76 CM) TO A TELEVISION SET.
 - **DO NOT** LOCATE ADDITIONAL CROSS-TRAINERS ANY CLOSER THAN 42 INCHES (107 CM) FROM CENTER TO CENTER TO AVOID INTERFERENCE (CROSS TALK) BETWEEN HEART RATE MONITORS.
 - **DO** KEEP THE AREA AROUND YOUR CROSS-TRAINER CLEAR OF ANY OBSTRUCTIONS, INCLUDING WALLS AND FURNITURE. ENSURE THAT THERE IS AT LEAST A 12 INCH (30 CM) CLEARANCE IN FRONT OF THE CROSS-TRAINER.
 - **DO** VERIFY THE CONTENTS OF THE DELIVERY CARTON AGAINST THE ACCOMPANYING PARTS LIST PRIOR TO SETTING THE CARTONS AND SHIPPING MATERIAL ASIDE. IF ANY PARTS ARE MISSING, CONTACT LIFE FITNESS CUSTOMER SUPPORT SERVICES AT THE NUMBER LISTED IN THE OPERATION MANUAL. SAVE THE SHIPPING CARTONS IN CASE OF RETURN.
 - **DO** READ THE ENTIRE OPERATION MANUAL PRIOR TO ATTEMPTING TO OPERATE THIS MACHINE AS THIS IS ESSENTIAL FOR PROPER USE.
-

CONSIGNES DE SECURITE IMPORTANTES!

- **NE** PLACEZ PAS L'APPAREIL À L'EXTÉRIEUR, PRÈS D'UNE PISCINE OU DANS UN ENDROIT TRÈS HUMIDE.
- **NE** FAITES PAS FONCTIONNER L'APPAREIL S'IL EST TOMBÉ, S'IL A ÉTÉ ENDOMMAGÉ OU S'IL A ÉTÉ PARTIELLEMENT PLONGÉ DANS L'EAU. SI CELA S'EST PRODUIT, CONTACTEZ LE SERVICE APRÈS-VENTE DE LIFE FITNESS AU NUMÉRO FOURNI DANS LE MANUEL D'UTILISATION.
- **NE** PLACEZ PAS L'APPAREIL À MOINS DE 76 CM D'UN POSTE DE TÉLÉVISION.
- **NE** PLACEZ PAS D'AUTRES APPAREILS DU MÊME TYPE À PROXIMITÉ. UN ESPACE D'AU MOINS 107 CM DOIT ÊTRE OBSERVÉ ENTRE LES PARTIES CENTRALES DE DEUX APPAREILS AFIN D'ÉVITER LES INTERFÉRENCES ENTRE LES CONTRÔLEURS DE RYTHME CARDIAQUE.
- **MAINTENEZ** LA ZONE AUTOUR DE L'APPAREIL LIBRE DE TOUTE OBSTRUCTION, Y COMPRIS MURS ET MEUBLES. VEILLEZ À LAISSER UN DÉGAGEMENT D'AU MOINS 30 CM DEVANT L'APPAREIL.
- **VÉRIFIEZ** SI L'EMBALLAGE CONTIENT TOUTES LES PIÈCES DE LA LISTE JOINTE AVANT DE LE METTRE DE CÔTÉ. SI DES PIÈCES SONT ABSENTES, CONTACTEZ LE SERVICE APRÈS-VENTE DE LIFE FITNESS AU NUMÉRO INDIQUÉ DANS LE MANUEL D'UTILISATION. CONSERVEZ L'EMBALLAGE AU CAS OÙ VOUS DEVRIEZ RENVoyer L'APPAREIL.
- **LISEZ** LE MANUEL DE L'UTILISATEUR TOUT ENTIER AVANT D'ESSAYER DE FAIRE FONCTIONNER CET APPAREIL. CECI EST INDISPENSABLE À SON UTILISATION CORRECTE.

TOOLS REQUIRED FOR ASSEMBLY...

Magnetic #2 Bit Phillips Screwdriver, T-45 Hex Key Wrench, 16mm Open End Wrench

PARTS DESCRIPTION

| | | | | | |
|----|--|---------|----|--|---------|
| 1 | Torx Socket Head Screw M8 – 1.25 x 19 0017-00101-1791 | Qty: 16 | 2 | Phillips Pan Head Screw M4 – 0.70 x 19 0017-00101-1796 | Qty: 14 |
| 3 | Phillips Pan Head Screw M4.2 – 0.70 x 10 0017-00101-1846 | Qty: 2 | 4 | Console Assembly | Qty: 1 |
| 5 | Front Rocker Cover OK62-01009-0000 | Qty: 2 | 6 | Left Back Rocker Cover OK62-01011-0000 | Qty: 1 |
| 7 | Console Support Assembly OK62-00123-0000 | Qty: 1 | 8 | Console Support Cover OK62-01023-0000 | Qty: 1 |
| 9 | Front Pivot Arm Cover OK62-01012-0000 | Qty: 2 | 10 | Rear Pivot Arm Cover OK62-01013-0000 | Qty: 2 |
| 11 | Left User Arm Assembly AK62-00087-0000 | Qty: 1 | 12 | Right User Arm Assembly AK62-00086-0000 | Qty: 1 |
| 13 | Left Bullhorn AK62-00054-0000 | Qty: 1 | 14 | Right Bullhorn AK62-00053-0000 | Qty: 1 |
| 15 | Left Bullhorn Cover OK62-01008-0001 | Qty: 1 | 16 | Right Bullhorn Cover OK62-01007-0001 | Qty: 1 |
| 17 | Accessory Tray OK62-01022-0000 | Qty: 1 | 18 | Right Back Rocker Cover OK62-01010-0000 | Qty: 1 |
| 19 | Base Frame Cap OK62-01004-0000 | Qty: 1 | 20 | Foot Cover OK62-01003-0000 | Qty: 4 |
| 21 | Cap: Console Support OK62-01030-0000 | Qty: 1 | 22 | Phillips Pan Head Screw M4 – 0.70 x 44 0017-00101-1854 | Qty: 2 |

1

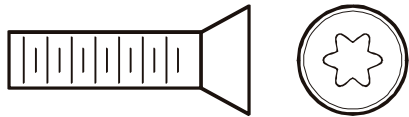

2



3



22

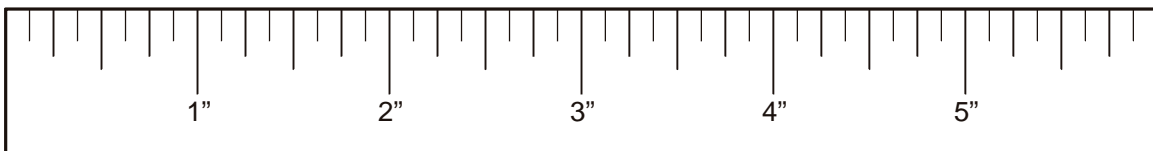

IMPORTANT!
DO NOT DISCARD THE SHIP KIT LOCATED ON TOP OF THE PEDAL LEVERS. ALL NECESSARY COMPONENTS NEEDED TO COMPLETE THE INSTALLATION ARE LOCATED IN THE SHIP KIT.

IMPORTANT!
NE JETEZ PAS LE KIT PLACÉ SUR LE DESSUS DES LEVIERS DE PÉDALE. IL CONTIENT TOUS LES ÉLÉMENTS NÉCESSAIRES POUR L'INSTALLATION.

1. Locate the LEFT HANDLEBAR (11). Position the HANDLEBAR near the top of the LEFT PIVOT ARM (A).

If equipped with Lifepulse, connect the 2-PIN HEART RATE CONNECTOR (B) leading from the HANDLEBAR to the 2-PIN CONNECTOR (C) extending from the top of the LEFT PIVOT ARM. Carefully slide the excess HEART RATE CABLE into the top of the LEFT PIVOT ARM.

Align the mounting holes of the LEFT HANDLEBAR with the mounting holes at the top of the LEFT PIVOT ARM. Secure them together using three SCREWS (1).

NOTE: BE CAREFUL NOT TO PINCH THE HEART RATE CABLE WHEN SECURING THE LEFT HANDLEBAR TO THE LEFT PIVOT ARM.

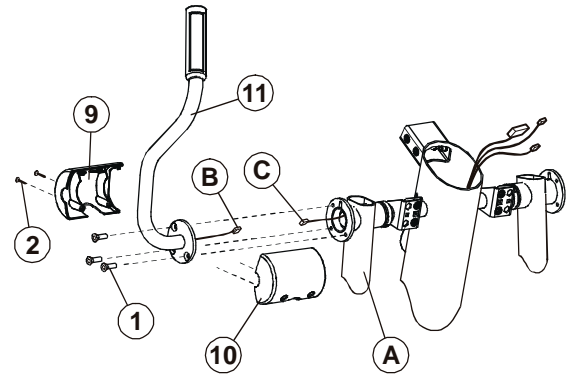

2. Locate one LEFT FRONT ROCKER COVER (5) and the LEFT BACK ROCKER COVER (6). Position the LEFT BACK ROCKER COVER over the user side of the ROCKER ARM making sure that it seats fully over the BULLHORN MOUNTING BRACKET (D). Place the FRONT ROCKER COVER over the opposite side of the ROCKER ARM in the same manner. Secure the COVERS using two PHILLIPS PAN HEAD SCREWS (2). Tighten the SCREWS securely. Do not over-tighten the SCREWS.

3. Locate one FRONT PIVOT ARM COVER (9) and one BACK PIVOT ARM COVER (10). Position the BACK PIVOT ARM COVER over the user side of the ROCKER ARM making sure that it interlocks with the ROCKER COVER. Place the FRONT PIVOT ARM COVER over the opposite side of the PIVOT ARM in the same manner. Secure the COVERS using two PHILLIPS PAN HEAD SCREWS (2). Tighten the SCREWS securely. Do not over-tighten the SCREWS.

4. Locate the LEFT BULLHORN (13). Secure the BULLHORN to the BULLHORN MOUNTING BRACKET (D) using two FLAT HEAD SCREWS (1). Tighten the SCREWS securely. Locate and attach the LEFT BULLHORN COVER (15) to the base of the BULLHORN using one SCREW (22). Tighten the SCREW securely. Do not over-tighten the SCREW. Slide the GASKET (E) downward to meet the BULLHORN COVER.

5. Repeat steps one through four to install the RIGHT ROCKER COVERS (5 & 6), PIVOT ARM COVERS (9 & 10), BULLHORN (14) and BULLHORN COVER (16).

NOTE: THE RIGHT PIVOT ARM COVERS ARE REVERSED FRONT AND BACK. THE SCREWS WILL BE INSTALLED FROM THE REAR.

6. Unwrap the MAIN WIRE and HEART RATE HARNESS (F & G) leading from the MONOCOLUMN (H). Feed the WIRE HARNESSSES through the CONSOLE SUPPORT ASSEMBLY TUBE (I) located at the top and front of the MONOCOLUMN. Locate the CONSOLE SUPPORT ASSEMBLY (7) and position it near the top of the MONOCOLUMN. Feed the WIRE HARNESSSES through the CONSOLE SUPPORT ASSEMBLY as shown. Align the bottom mounting holes of the CONSOLE SUPPORT ASSEMBLY with those in the CONSOLE SUPPORT ASSEMBLY TUBE. Secure them together using six SCREWS (1). Tighten the SCREWS securely.

NOTE: BE CAREFUL NOT TO DAMAGE THE WIRE HARNESSSES (E & F) WHEN ROUTING IT THROUGH THE CONSOLE SUPPORT ASSEMBLY OR WHEN MOUNTING THE CONSOLE SUPPORT ASSEMBLY TO THE CONSOLE SUPPORT ASSEMBLY TUBE.

7. Locate the ACCESSORY TRAY (17). Slide the ACCESSORY TRAY into the top of the MONOCOLUMN (H) as shown. Be sure the ACCESSORY TRAY is fully seated.

NOTE: BE CAREFUL NOT TO DAMAGE THE MAIN WIRE HARNESS WHEN SLIDING THE ACCESSORY TRAY INTO THE MONOCOLUMN.

Secure the accessory tray to the CONSOLE SUPPORT ASSEMBLY using two SCREWS (3). Tighten the SCREWS securely. Do not over-tighten the SCREWS.

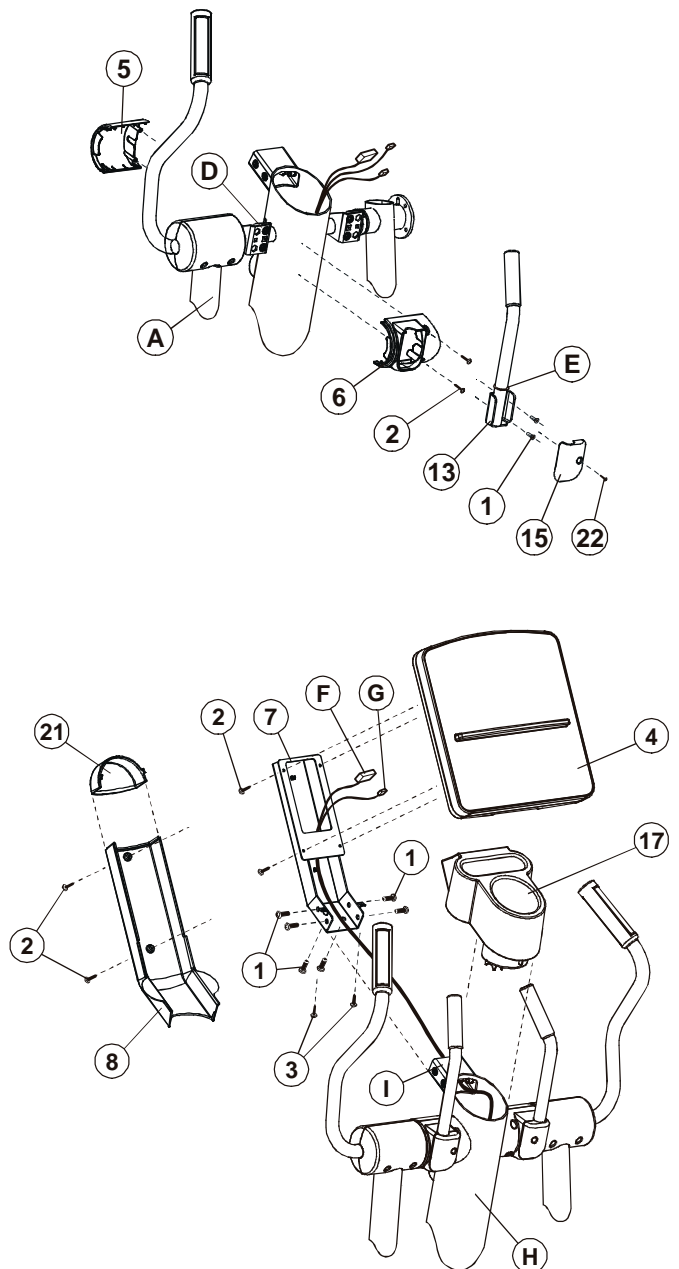

8. Locate the DISPLAY CONSOLE (4). Position the CONSOLE near the top of the CONSOLE BRACKET. Attach all CONNECTORS (F & G) leading from the CONSOLE BRACKET to their corresponding CONNECTORS in the back of the DISPLAY CONSOLE. Feed any excess WIRE HARNESS into the CONSOLE BRACKET and place the DISPLAY CONSOLE onto the CONSOLE BRACKET aligning the mounting holes. Secure the DISPLAY CONSOLE using four SCREWS (2). Tighten the SCREWS securely. Do not over-tighten the SCREWS.
9. Locate the CONSOLE SUPPORT COVER (8). Position the CONSOLE BRACKET COVER over the underside of the CONSOLE SUPPORT ASSEMBLY (7) as shown and secure it using two SCREWS (2). Tighten the SCREWS securely. Do not over-tighten the SCREWS.
10. Locate the CONSOLE SUPPORT CAP (21). Snap the CAP into position at the top of the CONSOLE SUPPORT COVER.
11. Locate the BASE FRAME CAP (19). Remove the two SCREWS (J) securing the front of the BASE FRAME COVER (K) to the BASE FRAME (L). Position the CAP over the front of the BASE FRAME as shown sliding the mounting tabs to the inside of the BASE FRAME COVER. Secure the CAP using two SCREWS (J) previously removed. Tighten THE SCREWS securely. Do not over-tighten the SCREWS.
12. Locate the four FOOT COVERS (20). Align the COVERS with the ends of the STABILIZER BARS (M). Insert the post on the underside of the FOOT COVERS into the mounting holes on the top of each STABILIZER. Press the FOOT COVERS firmly into position.
13. Position the unit into the desired location for use. Properly level the unit according to the instructions in the Operation Manual.

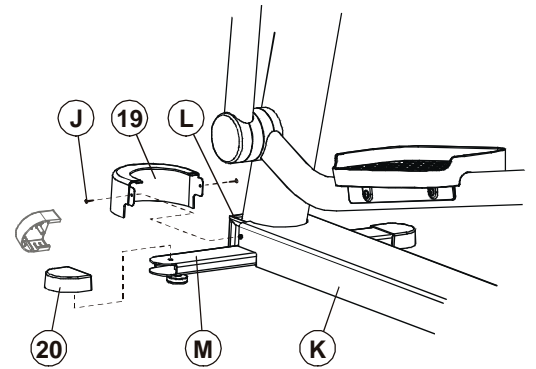
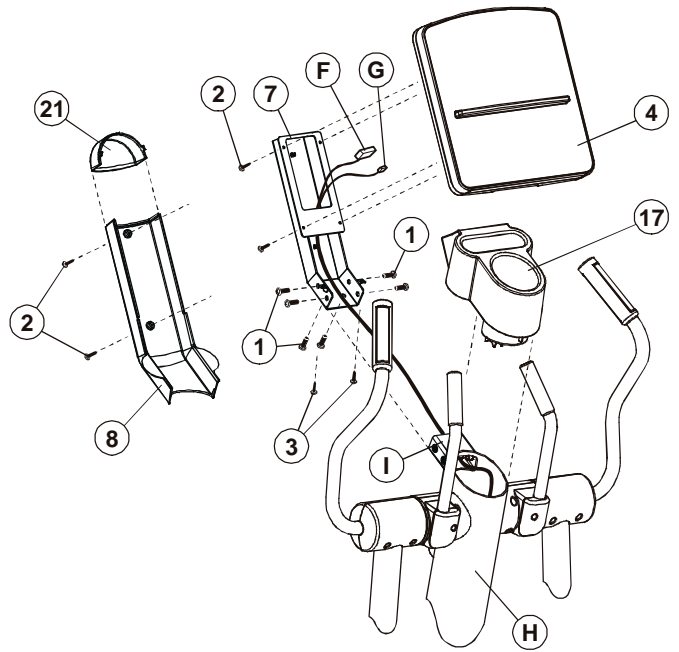

PRE-OPERATION CHECKLIST

- ✓ *Ensure that all fasteners are tight.*
 - ✓ *Make sure the CROSS-TRAINER is properly leveled and stable.
(Refer to the Operation Manual)*
 - ✓ *Ensure that the Leveler Jam Nuts are tight.
(Refer to the Operation Manual)*
 - ✓ *Read the entire Operation manual before using the Cross-Trainer.*
-

LISTE DES VÉRIFICATIONS À EFFECTUER AVANT LA MISE EN MARCHÉ

- ✓ *Vérifiez si tous les dispositifs de fixation sont serrés*
- ✓ *Vérifiez si l'APPAREIL D'EXERCICE POLYVALENT est de niveau et stable.
(Référez-vous au manuel d'utilisation.)*
- ✓ *Vérifiez si les contre-écrous des vérins de mise à niveau sont serrés.
(Référez-vous au manuel d'utilisation.)*
- ✓ *Lisez le manuel d'utilisation dans son intégralité avant d'utiliser l'appareil d'exercice polyvalent..*

Before attempting to operate your Cross-Trainer, it is imperative that you familiarize yourself with the contents of the Operation Manual. If your Cross-Trainer does not respond as described in the Operation Manual, contact the nearest Life Fitness service center as listed in the Operation Manual.

Life Fitness Customer Support Services
(800) 351-3737 or (847) 451-0036

Prior to your call, please be sure you have located and noted the

MODEL NUMBER & SERIAL NUMBER.

The Model & Serial number information of your Life Fitness Cross-Trainer is listed on a label located on the rear stabilizer.



Free Manuals Download Website

<http://myh66.com>

<http://usermanuals.us>

<http://www.somanuals.com>

<http://www.4manuals.cc>

<http://www.manual-lib.com>

<http://www.404manual.com>

<http://www.luxmanual.com>

<http://aubethermostatmanual.com>

Golf course search by state

<http://golfingnear.com>

Email search by domain

<http://emailbydomain.com>

Auto manuals search

<http://auto.somanuals.com>

TV manuals search

<http://tv.somanuals.com>