

INVERTEC® V155-S

For use with machines having Code Numbers: 11326; 11327

Safety Depends on You

Lincoln arc welding and cutting equipment is designed and built with safety in mind. However, your overall safety can be increased by proper installation ... and thoughtful operation on your part. **DO NOT INSTALL, OPERATE OR REPAIR THIS EQUIPMENT WITHOUT READING THIS MANUAL AND THE SAFETY PRECAUTIONS CONTAINED THROUGHOUT.** And, most importantly, think before you act and be careful.



SERVICE MANUAL

LINCOLN®
ELECTRIC

Copyright © Lincoln Global Inc.

• World's Leader in Welding and Cutting Products •

• Sales and Service through Subsidiaries and Distributors Worldwide •

Cleveland, Ohio 44117-1199 U.S.A. TEL: 888.935.3877 FAX: 216.486.1751 WEB SITE: www.lincolnelectric.com

Download from www.Somanuals.com. All Manuals Search And Download.

⚠ WARNING

⚠ CALIFORNIA PROPOSITION 65 WARNINGS ⚠

Diesel engine exhaust and some of its constituents are known to the State of California to cause cancer, birth defects, and other reproductive harm.

The Above For Diesel Engines

The engine exhaust from this product contains chemicals known to the State of California to cause cancer, birth defects, or other reproductive harm.

The Above For Gasoline Engines

ARC WELDING CAN BE HAZARDOUS. PROTECT YOURSELF AND OTHERS FROM POSSIBLE SERIOUS INJURY OR DEATH. KEEP CHILDREN AWAY. PACEMAKER WEARERS SHOULD CONSULT WITH THEIR DOCTOR BEFORE OPERATING.

Read and understand the following safety highlights. For additional safety information, it is strongly recommended that you purchase a copy of "Safety in Welding & Cutting - ANSI Standard Z49.1" from the American Welding Society, P.O. Box 351040, Miami, Florida 33135 or CSA Standard W117.2-1974. A Free copy of "Arc Welding Safety" booklet E205 is available from the Lincoln Electric Company, 22801 St. Clair Avenue, Cleveland, Ohio 44117-1199.

BE SURE THAT ALL INSTALLATION, OPERATION, MAINTENANCE AND REPAIR PROCEDURES ARE PERFORMED ONLY BY QUALIFIED INDIVIDUALS.



FOR ENGINE powered equipment.

- 1.a. Turn the engine off before troubleshooting and maintenance work unless the maintenance work requires it to be running.



- 1.b. Operate engines in open, well-ventilated areas or vent the engine exhaust fumes outdoors.



- 1.c. Do not add the fuel near an open flame welding arc or when the engine is running. Stop the engine and allow it to cool before refueling to prevent spilled fuel from vaporizing on contact with hot engine parts and igniting. Do not spill fuel when filling tank. If fuel is spilled, wipe it up and do not start engine until fumes have been eliminated.

- 1.d. Keep all equipment safety guards, covers and devices in position and in good repair. Keep hands, hair, clothing and tools away from V-belts, gears, fans and all other moving parts when starting, operating or repairing equipment.

- 1.e. In some cases it may be necessary to remove safety guards to perform required maintenance. Remove guards only when necessary and replace them when the maintenance requiring their removal is complete. Always use the greatest care when working near moving parts.



- 1.f. Do not put your hands near the engine fan. Do not attempt to override the governor or idler by pushing on the throttle control rods while the engine is running.

- 1.g. To prevent accidentally starting gasoline engines while turning the engine or welding generator during maintenance work, disconnect the spark plug wires, distributor cap or magneto wire as appropriate.



- 1.h. To avoid scalding, do not remove the radiator pressure cap when the engine is hot.



ELECTRIC AND MAGNETIC FIELDS may be dangerous

- 2.a. Electric current flowing through any conductor causes localized Electric and Magnetic Fields (EMF). Welding current creates EMF fields around welding cables and welding machines
- 2.b. EMF fields may interfere with some pacemakers, and welders having a pacemaker should consult their physician before welding.
- 2.c. Exposure to EMF fields in welding may have other health effects which are now not known.
- 2.d. All welders should use the following procedures in order to minimize exposure to EMF fields from the welding circuit:
- 2.d.1. Route the electrode and work cables together - Secure them with tape when possible.
- 2.d.2. Never coil the electrode lead around your body.
- 2.d.3. Do not place your body between the electrode and work cables. If the electrode cable is on your right side, the work cable should also be on your right side.
- 2.d.4. Connect the work cable to the workpiece as close as possible to the area being welded.
- 2.d.5. Do not work next to welding power source.

Mar '95



ELECTRIC SHOCK can kill.

3.a. The electrode and work (or ground) circuits are electrically "hot" when the welder is on. Do not touch these "hot" parts with your bare skin or wet clothing. Wear dry, hole-free gloves to insulate hands.

3.b. Insulate yourself from work and ground using dry insulation. Make certain the insulation is large enough to cover your full area of physical contact with work and ground.

In addition to the normal safety precautions, if welding must be performed under electrically hazardous conditions (in damp locations or while wearing wet clothing; on metal structures such as floors, gratings or scaffolds; when in cramped positions such as sitting, kneeling or lying, if there is a high risk of unavoidable or accidental contact with the workpiece or ground) use the following equipment:

- Semiautomatic DC Constant Voltage (Wire) Welder.
- DC Manual (Stick) Welder.
- AC Welder with Reduced Voltage Control.

3.c. In semiautomatic or automatic wire welding, the electrode, electrode reel, welding head, nozzle or semiautomatic welding gun are also electrically "hot".

3.d. Always be sure the work cable makes a good electrical connection with the metal being welded. The connection should be as close as possible to the area being welded.

3.e. Ground the work or metal to be welded to a good electrical (earth) ground.

3.f. Maintain the electrode holder, work clamp, welding cable and welding machine in good, safe operating condition. Replace damaged insulation.

3.g. Never dip the electrode in water for cooling.

3.h. Never simultaneously touch electrically "hot" parts of electrode holders connected to two welders because voltage between the two can be the total of the open circuit voltage of both welders.

3.i. When working above floor level, use a safety belt to protect yourself from a fall should you get a shock.

3.j. Also see Items 6.c. and 8.



ARC RAYS can burn.

4.a. Use a shield with the proper filter and cover plates to protect your eyes from sparks and the rays of the arc when welding or observing open arc welding. Headshield and filter lens should conform to ANSI Z87.1 standards.

4.b. Use suitable clothing made from durable flame-resistant material to protect your skin and that of your helpers from the arc rays.

4.c. Protect other nearby personnel with suitable, non-flammable screening and/or warn them not to watch the arc nor expose themselves to the arc rays or to hot spatter or metal.



FUMES AND GASES can be dangerous.

5.a. Welding may produce fumes and gases hazardous to health. Avoid breathing these fumes and gases. When welding, keep your head out of the fume. Use enough ventilation and/or exhaust at the arc to keep fumes and gases away from the breathing zone. **When welding with electrodes which require special ventilation such as stainless or hard facing (see instructions on container or MSDS) or on lead or cadmium plated steel and other metals or coatings which produce highly toxic fumes, keep exposure as low as possible and below Threshold Limit Values (TLV) using local exhaust or mechanical ventilation. In confined spaces or in some circumstances, outdoors, a respirator may be required. Additional precautions are also required when welding on galvanized steel.**

5.b. The operation of welding fume control equipment is affected by various factors including proper use and positioning of the equipment, maintenance of the equipment and the specific welding procedure and application involved. Worker exposure level should be checked upon installation and periodically thereafter to be certain it is within applicable OSHA PEL and ACGIH TLV limits.

5.c. Do not weld in locations near chlorinated hydrocarbon vapors coming from degreasing, cleaning or spraying operations. The heat and rays of the arc can react with solvent vapors to form phosgene, a highly toxic gas, and other irritating products.

5.d. Shielding gases used for arc welding can displace air and cause injury or death. Always use enough ventilation, especially in confined areas, to insure breathing air is safe.

5.e. Read and understand the manufacturer's instructions for this equipment and the consumables to be used, including the material safety data sheet (MSDS) and follow your employer's safety practices. MSDS forms are available from your welding distributor or from the manufacturer.

5.f. Also see item 1.b.

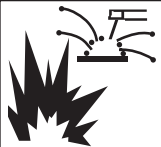

WELDING and CUTTING SPARKS can cause fire or explosion.

6.a. Remove fire hazards from the welding area. If this is not possible, cover them to prevent the welding sparks from starting a fire.

Remember that welding sparks and hot materials from welding can easily go through small cracks and openings to adjacent areas. Avoid welding near hydraulic lines. Have a fire extinguisher readily available.

6.b. Where compressed gases are to be used at the job site, special precautions should be used to prevent hazardous situations. Refer to "Safety in Welding and Cutting" (ANSI Standard Z49.1) and the operating information for the equipment being used.

6.c. When not welding, make certain no part of the electrode circuit is touching the work or ground. Accidental contact can cause overheating and create a fire hazard.

6.d. Do not heat, cut or weld tanks, drums or containers until the proper steps have been taken to insure that such procedures will not cause flammable or toxic vapors from substances inside. They can cause an explosion even though they have been "cleaned". For information, purchase "Recommended Safe Practices for the Preparation for Welding and Cutting of Containers and Piping That Have Held Hazardous Substances", AWS F4.1 from the American Welding Society (see address above).

6.e. Vent hollow castings or containers before heating, cutting or welding. They may explode.

6.f. Sparks and spatter are thrown from the welding arc. Wear oil free protective garments such as leather gloves, heavy shirt, cuffless trousers, high shoes and a cap over your hair. Wear ear plugs when welding out of position or in confined places. Always wear safety glasses with side shields when in a welding area.

6.g. Connect the work cable to the work as close to the welding area as practical. Work cables connected to the building framework or other locations away from the welding area increase the possibility of the welding current passing through lifting chains, crane cables or other alternate circuits. This can create fire hazards or overheat lifting chains or cables until they fail.

6.h. Also see item 1.c.

6.i. Read and follow NFPA 51B "Standard for Fire Prevention During Welding, Cutting and Other Hot Work", available from NFPA, 1 Batterymarch Park, PO box 9101, Quincy, Ma 022690-9101.

6.j. Do not use a welding power source for pipe thawing.



CYLINDER may explode if damaged.

7.a. Use only compressed gas cylinders containing the correct shielding gas for the process used and properly operating regulators designed for the gas and pressure used. All hoses, fittings, etc. should be suitable for the application and maintained in good condition.

7.b. Always keep cylinders in an upright position securely chained to an undercarriage or fixed support.

7.c. Cylinders should be located:

- Away from areas where they may be struck or subjected to physical damage.

- A safe distance from arc welding or cutting operations and any other source of heat, sparks, or flame.

7.d. Never allow the electrode, electrode holder or any other electrically "hot" parts to touch a cylinder.

7.e. Keep your head and face away from the cylinder valve outlet when opening the cylinder valve.

7.f. Valve protection caps should always be in place and hand tight except when the cylinder is in use or connected for use.

7.g. Read and follow the instructions on compressed gas cylinders, associated equipment, and CGA publication P-1, "Precautions for Safe Handling of Compressed Gases in Cylinders," available from the Compressed Gas Association 1235 Jefferson Davis Highway, Arlington, VA 22202.



FOR ELECTRICALLY powered equipment.

8.a. Turn off input power using the disconnect switch at the fuse box before working on the equipment.

8.b. Install equipment in accordance with the U.S. National Electrical Code, all local codes and the manufacturer's recommendations.

8.c. Ground the equipment in accordance with the U.S. National Electrical Code and the manufacturer's recommendations.

PRÉCAUTIONS DE SÛRETÉ

Pour votre propre protection lire et observer toutes les instructions et les précautions de sûreté spécifiques qui paraissent dans ce manuel aussi bien que les précautions de sûreté générales suivantes:

Sûreté Pour Soudage A L'Arc

1. Protégez-vous contre la secousse électrique:
 - a. Les circuits à l'électrode et à la pièce sont sous tension quand la machine à souder est en marche. Eviter toujours tout contact entre les parties sous tension et la peau nue ou les vêtements mouillés. Porter des gants secs et sans trous pour isoler les mains.
 - b. Faire très attention de bien s'isoler de la masse quand on soude dans des endroits humides, ou sur un plancher métallique ou des grilles métalliques, principalement dans les positions assis ou couché pour lesquelles une grande partie du corps peut être en contact avec la masse.
 - c. Maintenir le porte-électrode, la pince de masse, le câble de soudage et la machine à souder en bon et sûr état de fonctionnement.
 - d. Ne jamais plonger le porte-électrode dans l'eau pour le refroidir.
 - e. Ne jamais toucher simultanément les parties sous tension des porte-électrodes connectés à deux machines à souder parce que la tension entre les deux pinces peut être le total de la tension à vide des deux machines.
 - f. Si on utilise la machine à souder comme une source de courant pour soudage semi-automatique, ces précautions pour le porte-électrode s'appliquent aussi au pistolet de soudage.
2. Dans le cas de travail au dessus du niveau du sol, se protéger contre les chutes dans le cas où on reçoit un choc. Ne jamais enrouler le câble-électrode autour de n'importe quelle partie du corps.
3. Un coup d'arc peut être plus sévère qu'un coup de soleil, donc:
 - a. Utiliser un bon masque avec un verre filtrant approprié ainsi qu'un verre blanc afin de se protéger les yeux du rayonnement de l'arc et des projections quand on soude ou quand on regarde l'arc.
 - b. Porter des vêtements convenables afin de protéger la peau de soudeur et des aides contre le rayonnement de l'arc.
 - c. Protéger l'autre personnel travaillant à proximité au soudage à l'aide d'écrans appropriés et non-inflammables.
4. Des gouttes de laitier en fusion sont émises de l'arc de soudage. Se protéger avec des vêtements de protection libres de l'huile, tels que les gants en cuir, chemise épaisse, pantalons sans revers, et chaussures montantes.
5. Toujours porter des lunettes de sécurité dans la zone de soudage. Utiliser des lunettes avec écrans latéraux dans les zones où l'on pique le laitier.

6. Eloigner les matériaux inflammables ou les recouvrir afin de prévenir tout risque d'incendie dû aux étincelles.
7. Quand on ne soude pas, poser la pince à un endroit isolé de la masse. Un court-circuit accidentel peut provoquer un échauffement et un risque d'incendie.
8. S'assurer que la masse est connectée le plus près possible de la zone de travail qu'il est pratique de le faire. Si on place la masse sur la charpente de la construction ou d'autres endroits éloignés de la zone de travail, on augmente le risque de voir passer le courant de soudage par les chaînes de levage, câbles de grue, ou autres circuits. Cela peut provoquer des risques d'incendie ou d'échauffement des chaînes et des câbles jusqu'à ce qu'ils se rompent.
9. Assurer une ventilation suffisante dans la zone de soudage. Ceci est particulièrement important pour le soudage de tôles galvanisées plombées, ou cadmiées ou tout autre métal qui produit des fumées toxiques.
10. Ne pas souder en présence de vapeurs de chlore provenant d'opérations de dégraissage, nettoyage ou pistolage. La chaleur ou les rayons de l'arc peuvent réagir avec les vapeurs du solvant pour produire du phosgène (gas fortement toxique) ou autres produits irritants.
11. Pour obtenir de plus amples renseignements sur la sûreté, voir le code "Code for safety in welding and cutting" CSA Standard W 117.2-1974.

PRÉCAUTIONS DE SÛRETÉ POUR LES MACHINES À SOUDER À TRANSFORMATEUR ET À REDRESSEUR

1. Relier à la terre le châssis du poste conformément au code de l'électricité et aux recommandations du fabricant. Le dispositif de montage ou la pièce à souder doit être branché à une bonne mise à la terre.
2. Autant que possible, l'installation et l'entretien du poste seront effectués par un électricien qualifié.
3. Avant de faire des travaux à l'intérieur de poste, la débrancher à l'interrupteur à la boîte de fusibles.
4. Garder tous les couvercles et dispositifs de sûreté à leur place.

Mar '93

Electromagnetic Compatibility (EMC)

Conformance

Products displaying the CE mark are in conformity with European Community Council Directive of 3 May 1989 on the approximation of the laws of the Member States relating to electromagnetic compatibility (89/336/EEC). It was manufactured in conformity with a national standard that implements a harmonized standard: **EN 60974-10** Electromagnetic Compatibility (EMC) Product Standard for Arc Welding Equipment. It is for use with other Lincoln Electric equipment. It is designed for industrial and professional use.

Introduction

All electrical equipment generates small amounts of electromagnetic emission. Electrical emission may be transmitted through power lines or radiated through space, similar to a radio transmitter. When emissions are received by other equipment, electrical interference may result. Electrical emissions may affect many kinds of electrical equipment; other nearby welding equipment, radio and TV reception, numerical controlled machines, telephone systems, computers, etc. Be aware that interference may result and extra precautions may be required when a welding power source is used in a domestic establishment.

Installation and Use

The user is responsible for installing and using the welding equipment according to the manufacturer's instructions. If electromagnetic disturbances are detected then it shall be the responsibility of the user of the welding equipment to resolve the situation with the technical assistance of the manufacturer. In some cases this remedial action may be as simple as earthing (grounding) the welding circuit, see Note. In other cases it could involve construction of an electromagnetic screen enclosing the power source and the work complete with associated input filters. In all cases electromagnetic disturbances must be reduced to the point where they are no longer troublesome.

Note: The welding circuit may or may not be earthed for safety reasons according to national codes. Changing the earthing arrangements should only be authorized by a person who is competent to access whether the changes will increase the risk of injury, e.g., by allowing parallel welding current return paths which may damage the earth circuits of other equipment.

Assessment of Area

Before installing welding equipment the user shall make an assessment of potential electromagnetic problems in the surrounding area. The following shall be taken into account:

- a) other supply cables, control cables, signaling and telephone cables; above, below and adjacent to the welding equipment;
- b) radio and television transmitters and receivers;
- c) computer and other control equipment;
- d) safety critical equipment, e.g., guarding of industrial equipment;
- e) the health of the people around, e.g., the use of pacemakers and hearing aids;
- f) equipment used for calibration or measurement
- g) the immunity of other equipment in the environment. The user shall ensure that other equipment being used in the environment is compatible. This may require additional protection measures;
- h) the time of day that welding or other activities are to be carried out.

L10093 3-1-96H

Electromagnetic Compatibility (EMC)

The size of the surrounding area to be considered will depend on the structure of the building and other activities that are taking place. The surrounding area may extend beyond the boundaries of the premises.

Methods of Reducing Emissions

Mains Supply

Welding equipment should be connected to the mains supply according to the manufacturer's recommendations. If interference occurs, it may be necessary to take additional precautions such as filtering of the mains supply. Consideration should be given to shielding the supply cable of permanently installed welding equipment, in metallic conduit or equivalent. Shielding should be electrically continuous throughout its length. The shielding should be connected to the welding power source so that good electrical contact is maintained between the conduit and the welding power source enclosure.

Maintenance of the Welding Equipment

The welding equipment should be routinely maintained according to the manufacturer's recommendations. All access and service doors and covers should be closed and properly fastened when the welding equipment is in operation. The welding equipment should not be modified in any way except for those changes and adjustments covered in the manufacturer's instructions. In particular, the spark gaps of arc striking and stabilizing devices should be adjusted and maintained according to the manufacturer's recommendations.

Welding Cables

The welding cables should be kept as short as possible and should be positioned close together, running at or close to floor level.

Equipotential Bonding

Bonding of all metallic components in the welding installation and adjacent to it should be considered. However, metallic components bonded to the work piece will increase the risk that the operator could receive a shock by touching these metallic components and the electrode at the same time. The operator should be insulated from all such bonded metallic components.

Earthing of the Workpiece

Where the workpiece is not bonded to earth for electrical safety, not connected to earth because of its size and position, e.g., ships hull or building steelwork, a connection bonding the workpiece to earth may reduce emissions in some, but not all instances. Care should be taken to prevent the earthing of the workpiece increasing the risk of injury to users, or damage to other electrical equipment. Where necessary, the connection of the workpiece to earth should be made by a direct connection to the workpiece, but in some countries where direct connection is not permitted, the bonding should be achieved by suitable capacitance, selected according to national regulations.

Screening and Shielding

Selective screening and shielding of other cables and equipment in the surrounding area may alleviate problems of interference. Screening of the entire welding installation may be considered for special applications. ¹

¹ Portions of the preceding text are contained in EN 60974-10: "Electromagnetic Compatibility (EMC) product standard for arc welding equipment."

I - MASTER TABLE OF CONTENTS FOR ALL SECTIONS - I

	Page
Safetyi-iv
Installation	Section A
Operation	Section B
Accessories	Section C
Maintenance	Section D
Theory of Operation	Section E
Troubleshooting and Repair	Section F
Electrical Diagrams	Section G
Parts ManualP-559

INVERTEC® V155-S



Installation **A-1**

 Technical Specifications A-2

 Safety Precautions A-3

 Location A-3

 Input Connection A-3

 Output Connections A-5

Return to Master TOC

Return to Master TOC

Return to Master TOC

Return to Master TOC

INVERTEC® V155-S



INPUT - SINGLE PHASE ONLY

Input Voltages / 50 /60 Hz.	Max. Input Current at rated Output		Input Power at Rated Output	
	100%	30%	100%	30%
120Vac ± 10%	25A	34 A	2.2kw	3.0kw
230Vac ± 10%	23A	33 A	3.0kw	5.0kw

RATED OUTPUT

Duty Cycle	Output Amps	Output Volts	Input Circuit
100%	75A (Stick) 105A (TIG)	23.0 Vdc 14.2 Vdc	120 Vac
	100A (Stick) 100A (TIG)	24.0 Vdc 14.0 Vdc	230 Vac
30%	100A (Stick) 130A (TIG)	24.0 Vdc 15.2 Vdc	120 Vac
	145A (Stick) 155A (TIG)	25.8 Vdc 16.2 Vdc	230 Vac

OUTPUT

Output Current Range	Maximum Open Circuit Voltage	Type of Output
5-155 Amps	75 Volts Max.	DC

RECOMMENDED INPUT WIRE AND FUSE SIZES FOR MAXIMUM RATED OUTPUT

INPUT VOLTAGE / FREQUENCY (HZ)	TYPE S, SO ST, STO, OR EXTRA HARD USAGE INPUT CORD AWG	MAXIMUM TIME-DELAY CIRCUIT BREAKER OR FUSE SIZE (AMPS)
230/60 120/60	3 Conductor, 12 AWG	30

PHYSICAL DIMENSIONS

Height	Width	Depth	Weight
11.3 288 mm	6.2 in. 158 mm	15.4in. 392 mm	Approx. 14.7lbs. 6.7 kgs.

TEMPERATURE RANGES

OPERATING TEMPERATURE RANGE	STORAGE TEMPERATURE RANGE
-10°C to +40°C	-25°C to +55°C

INVERTEC® V155-S



Read entire installation section before starting installation.

SAFETY PRECAUTIONS

⚠ WARNING



ELECTRIC SHOCK can kill.

- Only qualified personnel should perform this installation.
- Disconnect input power by removing plug from receptacle before working inside INVERTEC® V155-S. Allow machine to sit for 5 minutes minimum to allow the power capacitors to discharge before working inside this equipment.

- Insulate yourself from the work and ground.
- Always wear dry insulating gloves.
- Always connect the INVERTEC® V155-S to a power supply grounded according to the National Electrical Code and local codes.

SELECT SUITABLE LOCATION

This machine can operate in harsh environments. However, it is important that simple preventative measures are followed to assure long life and reliable operation:

- Do not use this machine for pipe thawing.
- This machine must be located where there is free circulation of clean air without restrictions for air movement to and from the air vents. Do not cover the machine with paper, cloth or rags when switched on.
- Dirt and dust that can be drawn into the machine should be kept to a minimum.
- This machine has a protection rating of IP23. Keep it dry when possible and do not place it on wet ground or in puddles.
- Locate the machine away from radio controlled machinery. Normal operation may adversely affect the operation of nearby radio controlled machinery, which may result in injury or equipment damage. Read the section on electromagnetic compatibility in this manual.
- Do not operate in areas with an ambient temperature greater than 40°C.

STACKING

The INVERTEC® V155-S cannot be stacked.

TILTING

Place the machine directly on a secure, level surface. Do not place or operate this machine on a surface with an incline greater than 15° from horizontal. The machine may topple over if this procedure is not followed.

INPUT CONNECTIONS

⚠ WARNING

ELECTRIC SHOCK can kill.



- Have a qualified electrician install and service this equipment.
- Disconnect input power by removing plug from receptacle before working inside INVERTEC® V155-S. Allow machine to sit for 5 minutes minimum to allow the power capacitors to discharge before working inside this equipment.
- Do not touch electrically live parts.



GROUND CONNECTION

The frame of the welder must be grounded. A ground terminal marked with the symbol is located on the under panel for this purpose. See your local and national electrical codes for proper grounding methods.

⚠ CAUTION

A grounding conductor is supplied in the input cord, it is important that the supply receptacle ground is connected.

⚠ WARNING

This installation should be performed by a qualified electrician to ensure correct connections of the leads to the plug spades.

- The electrical system must be made by skilled technicians with the specific professional and technical qualifications and in compliance with the regulations in force in the country where the equipment is installed.
- The welding power source supply cable is provided with a green or yellow/green wire that must **ALWAYS** be earthed. This green or yellow/green wire must **NEVER** be used with other voltage conductors.
- Install only plugs that confirm with safety regulations.

INVERTEC® V155-S



INPUT POWER CONNECTION

Check the input voltage, phase, and frequency supplied to this machine before turning it on. The allowable input voltage is indicated in the technical specification section of this manual and on the rating plate of the machine. Be sure that the machine is grounded.

Make sure the power available at the input connection is adequate for normal operation of the machine. The fuse rating and cable sizes are both indicated in the technical specification section of this manual.

Fuse the input circuit with time delay fuses marked “D” or delay type¹ circuit breakers. Using fuses or circuit breakers smaller than recommended may result in “nuisance” shut-offs from welder inrush currents even if not welding at high currents.

¹Also called “inverse time” or “thermal/magnetic” circuit breakers. These circuit breakers have a delay in tripping action that decreases as the magnitude of the current increases.

The INVERTEC® V155-S is recommended for use on an individual branch circuit.

120V INPUT

The rated output of the INVERTEC® V155-S is available when connected to a 30A branch circuit. When connected to a branch circuit with lower ampacity, lower welding current and duty cycle must be used. An output guide is provided below. The values are approximate and must be adjusted downward if the fuse or circuit breaker trips off. Other loads on the circuit and fuse/circuit breaker characteristics will affect the available output. Do not exceed these welding conditions: (See Table A.1)

The INVERTEC® V155-S is provided with a 120/230V cable, 6.6ft.(2m) in length, with a 15Amp 5-15P plug molded onto the cord.

The INVERTEC® V155-S is supplied with an additional 20A plug that can replace the 15A plug to achieve higher output. To install the supplied 20A plug:

Connect the white (neutral) wire under terminal clamp with silver screw, and black (hot) wire under terminal clamp with brass screw. Connect green wire under terminal clamp with green screw.

TABLE A.1

120V Input		BRANCH Output Current					
		Stick			TIG		
Plug Rating	Branch Rating	10% Duty Cycle	30% Duty Cycle	100% Duty Cycle	10% Duty Cycle	30% Duty Cycle	100% Duty Cycle
15 Amp	15 Amp	65A	55A	45A	100A	85A	75A
15 Amp	20 Amp	75A	70A	60A	110A	100A	95A
20 Amp	20 Amp	85A	75A	60A	130A	130A	95A

INVERTEC® V155-S



⚠ WARNING

. Failure to wire as instructed may cause personal injury or damage to equipment. To be installed or checked by an electrician or qualified person only.

230V INPUT

To achieve the full output capacity of the INVERTEC® V155-S, 230VAC inputs should be used. The change over is accomplished by replacing the 120VAC plug with a 30 Amp 230VAC plug (NEMA 6-30P).

ATTACHMENT PLUG

In all cases, the green or green/yellow grounding wire must be connected to the grounding pin of the plug, usually identified by a green screw.

All attachment plugs must comply with the Standard for Attachment Plugs and Receptacles, UL498.

The product is considered acceptable for use only when an attachment plug as specified is properly attached to the supply cord.

The INVERTEC® V155-S will auto reconnect to either 120V or 230V supplies.

ENGINE DRIVEN GENERATOR

The machine is designed to operate on engine driven generators as long as the auxiliary can supply adequate voltage, frequency and power as indicated in the "Technical Specification" Installation Section of this manual. The auxiliary supply of the generator must also meet the following conditions:

- Vac peak voltage: below 205V (for 115Vac input) or 410V (for 230Vac input).
- Vac frequency: in the range of 50 or 60 Hertz.
- RMS voltage of the AC waveform: 115Vac or 230Vac ± 10%

It is important to check these conditions because many engine driven generators produce high voltage spikes. Operation of this machine with engine driven generators not conforming to these conditions is not recommended and may damage the machine.

Return to Section TOC | Return to Master TOC

ARFU (Auto-Restore Fuse)

The dual input voltage machine is provided with the ARFU device. It operates only when the input is connected to the 120Vac mains and protects from input overcurrent. When active, the "Thermal LED" lights (see "Controls and Operational Features" in the Operation Section).

Note: The ARFU device operates independently from the machine's duty-cycle.

OUTPUT CONNECTIONS

A quick disconnect system using Twist-Mate™ cable plugs is used for the welding cable connections. Refer to the following sections for more information on connecting the machine for operation of stick welding (SMAW) or TIG welding.

⚠ WARNING



ELECTRIC SHOCK can kill.

- Keep the electrode holder and cable insulation in good condition.
- Do not touch electrically live parts or electrode with skin or wet clothing.
- Insulate yourself from work and ground.
- Turn the input line Switch on the INVERTEC® V155-S "off" before connecting or disconnecting output cables or other equipment.

STICK WELDING (SMAW)

First determine the proper electrode polarity for the electrode to be used. Consult the electrode data for this information. Then connect the output cables to the output terminals of the machine for the selected polarity. Shown here is the connection method for DC(+) welding. (See Figure A.1)

Connect the electrode cable to the (+) terminal and the work clamp to the (-) terminal. Insert the connector with the key lining up with the keyway and rotate approximately 1/4 turn clockwise. Do not over tighten.

For DC(-) welding, switch the cable connections at the machine so that the electrode cable is connected to (-) and the work clamp is connected to (+).

FIGURE A.1

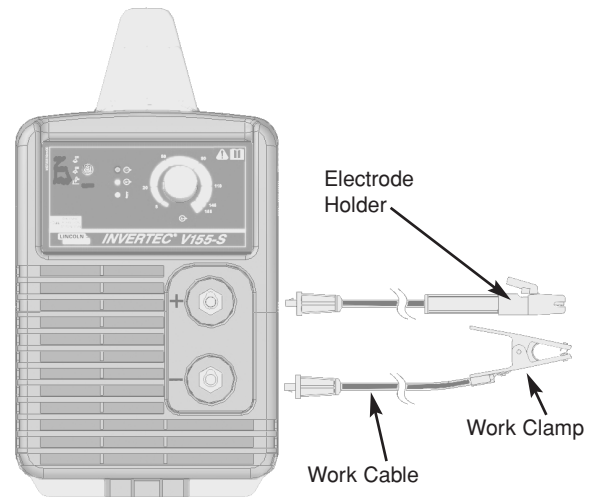

TIG WELDING

This machine does not have a built in Gas Solenoid so a one piece gas valve TIG Torch is required. A K960-2 Twist-Mate™ TIG Torch adapter is also required. Refer to the accessories section for more information about TIG Torches and required Twist-Mate™ adapter. Most TIG welding is done with DC(-) polarity shown here. If DC(+) polarity is necessary switch the cable connections at the machine. (See Figure A.2)

Connect the torch cable to the (-) terminal of the machine and the work clamp to the (+) terminal. Insert the connector with the key lining up with the keyway and rotate approximately 1/4 turn clockwise. Do not over tighten. Finally, connect the Twist-Mate™ adapter gas hose to the gas regulator on the cylinder of gas to be used.

FIGURE A.2

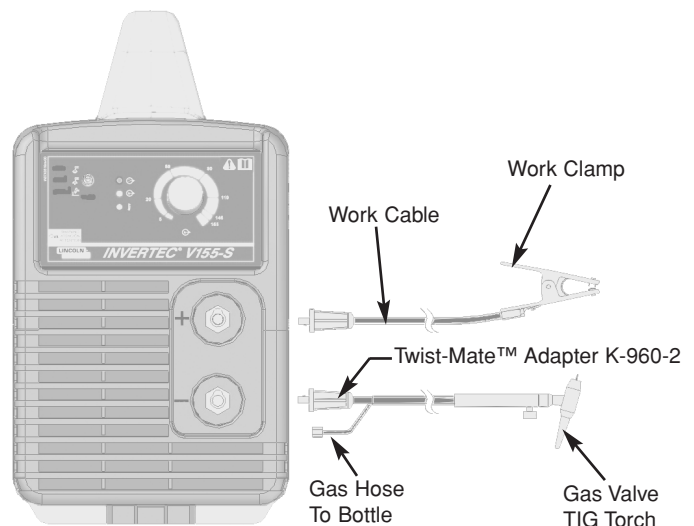

INVERTEC® V155-S



REPLACEMENT QUICK DISCONNECT PLUG (FOR STICK ELECTRODE CABLE)

The INVERTEC® V155-S comes with a factory assembled stick electrode holder, cable and Twist-Mate™ adapter plug. If a replacement cable is ever needed a K852-25 Twist-Mate™ plug will be needed.

To attach the K852-25 plug:

1. Cut off welding cable lug, if present.
2. Remove .75 in. (19mm) of welding cable insulation.
3. Slide rubber boot onto cable end. The boot end may be trimmed to match the cable diameter. Use soap or other nonpetroleum-based lubricant to help slide the boot over the cable, if needed.

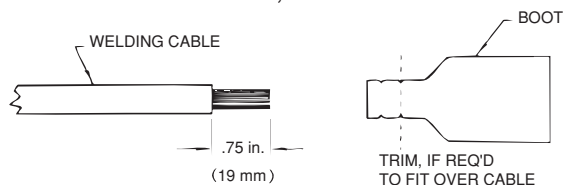

4. Cut 45-50% of the copper strands back 1/4" (6 mm).
5. Fold copper strands over cut strands and insert into

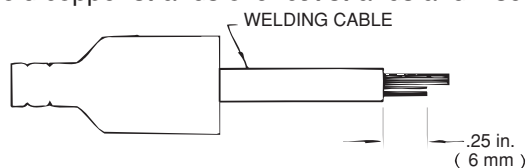

ferrule.

6. Slide the copper ferrule into the brass plug.

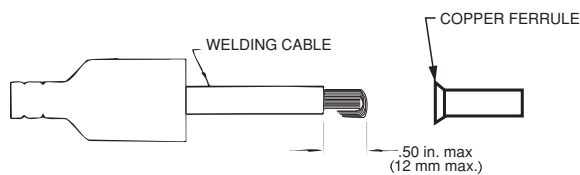

7. Tighten set screw to collapse copper tube. Screw

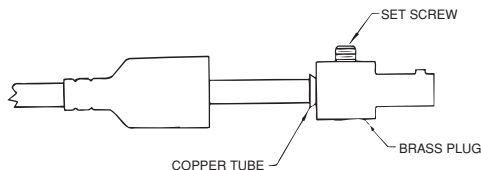

must apply pressure against welding cable. The top of the set screw will be well below the surface of the brass plug after tightening.

INVERTEC® V155-S



OperationB-1

Safety PrecautionsB-2

General DescriptionB-2

Controls and Operational FeaturesB-3

Return to Master TOC

Return to Master TOC

Return to Master TOC

Return to Master TOC

INVERTEC® V155-S



Read and understand this entire section before operating your machine.

SAFETY INSTRUCTIONS

WARNING



ELECTRIC SHOCK can kill.

- Do not touch electrically live parts such as output terminals or internal wiring.
- Insulate yourself from the work and ground.
- Always wear dry insulating gloves.



FUMES AND GASES can be dangerous.

- Keep your head out of fumes.
- Use ventilation or exhaust to remove fumes from breathing zone.

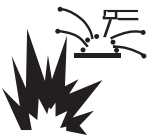

WELDING, CUTTING and GOUGING SPARKS can cause fire or explosion

- Keep flammable material away.
- Do not weld, cut or gouge on containers that have held combustibles.



ARC RAYS can burn.

- Wear eye, ear and body protection.

Only qualified personnel should operate this equipment. Observe all safety information throughout this manual.

GENERAL DESCRIPTION

The INVERTEC® V155-S is an industrial 155 amp arc welding power source which utilizes single phase input power, to produce constant current output. The welding response of this Invertec has been optimized for stick (SMAW) and Touch Start TIG (GTAW). The unit is ideal for industrial applications where portability is important.

The INVERTEC® V155-S is recommended for stick welding with such popular electrodes as Fleetweld 35, Fleetweld 37, Fleetweld 180 and LH 78. It features automatic arc control to adjust the arc force, hot start and anti sticking. The machine also features soft and crisp modes.

The INVERTEC® V155-S performs DC Touch Start Tig Starting with excellent results.

WELDING CAPABILITY

The INVERTEC® V155-S is rated at 155 amps, 16.2 volts, at 30% duty cycle on a ten minute basis. It is capable of higher duty cycles at lower output currents⁽¹⁾. If the duty cycle is exceeded, a thermal protector will shut off the output until the machine cools. See Technical Specifications in the Installation Section for other rated outputs.

The INVERTEC® V155-S is recommended for stick welding with such popular electrodes as Fleetweld® 35, Fleetweld 37, Fleetweld 180 and Jet-LH 78 MR. It features adjustable arc control to adjust the arc force and start.

LIMITATIONS

The INVERTEC® V155-S is not recommended for pipe thawing.

⁽¹⁾ Refer to Technical Specifications in the Installation Section for other ratings.



INVERTEC® V155-S



CONTROLS AND OPERATIONAL FEATURES

1. Output Current Knob:  Potentiometer used to set the output current used during welding, from 5A to 155A.

2. Welding Mode Switch: With three positions, controls the welding mode of the machine: two for Stick welding (Soft and Crisp) and one for Lift TIG welding.

- Soft Stick:  For a welding with a low spatter presence.
- Crisp Stick:  For an aggressive welding arc, with an increased Arc stability.
- Lift TIG:  When the mode switch is in the Lift TIG position, the stick welding functions are disabled and the machine is ready for Lift TIG welding. Lift TIG is a method of starting a TIG weld by first pressing the TIG torch electrode on the work piece in order to create a low current short circuit. Then, the electrode is lifted from the work piece to start the TIG arc.

3. Thermal LED:  This indicator will turn on when the machine is overheated and the output has been disabled. This normally occurs when the duty cycle of the machine has been exceeded. Leave the machine on to allow the internal components to cool. When the indicator turns off, normal operation is again possible.

If the Yellow LED illuminates, and the Red and Green LED's blink on and off alternately, the unit is unable to cool itself adequately. Check to make sure the fan is not obstructed and the fan is operating properly. Prior to resuming normal operation, the unit must be turned off and turned back on to reset this error condition.

⚠ WARNING

If blinking, the Thermal LED indicates that the input voltage is out of ranges.

4. Power On/Off & OUTPUT LEDs: These LEDs (one green and one red) operates as described in the table below:



LED status		FUNCTION
Green ON	Red OFF	The machine is turned ON.  ON condition: The machine is at idle (no-welding time) and OCV is present.
OFF	ON	The machine is turned ON.  On condition: Presence of welding current at the output leads. This permanent LED condition, showed at idle (no-welding time), indicates machine damage.
OFF	OFF	The machine is turned OFF and/or the input cord could be disconnected from the mains. ERROR condition: With the Power Switch turned ON and the input cord properly connected to a "live" main supply, this LED condition indicates machine damage.
ON	ON	ERROR condition: This LED condition

FIGURE B.1



- 1. Output Current Knob
- 2. Welding Mode Switch
- 3. Thermal LED
- 4. Power On/Off and Output LED's
- 5. Positive Quick Disconnect
- 6. Negative Quick Disconnect

INVERTEC® V155-S

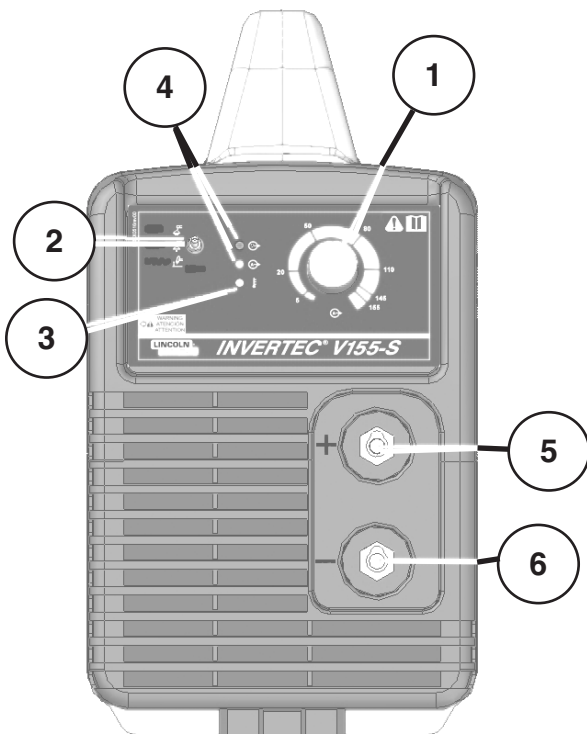

Return to Section TOC | Return to Master TOC

5. Positive Quick Disconnect: Positive output connector for the welding circuit.

6. Negative Quick Disconnect: Negative output connector for the welding circuit.

REAR CONTROL PANEL

(See Figure B.2)

7. Power Switch: It turns ON / OFF the input power to the machine.

8. Input cable: This machine is provided with a plugged input cord. Connect it to the mains.

9. Fan: This machine has a F.A.N. (Fan As Needed) circuitry inside: the fan is automatically turned ON or OFF. This feature reduces the amount of dirt which can be drawn inside the machine and reduces power consumption. The F.A.N. operates differently in different weld mode.

- **Stick mode:** When the machine is turned ON the fan will turn ON for a short time and then go off if a weld is not started. The fan will continue to run whenever the machine is welding. The fan will turn OFF five minutes after the welding is stopped.

- **TIG modes:** When the machine is turned ON the fan is OFF. The fan will turn ON only when a weld is started and it will continue to run whenever the machine is welding. The fan will turn OFF five minutes after the welding is stopped.

AUTO ADAPTIVE ARC FORCE (WITH STICK WELDING)

The Auto Adaptive Arc Force function is activated during stick welding. This function temporarily increases the output current, to clear intermittent shorts between the electrode and the weld puddle that may occur during stick welding.

This is an active control feature that guarantees the best arrangement between the arc stability and spatter presence. The feature "Auto Adaptive Arc Force" has instead of a fixed or manual regulation, an automatic and multilevel setting: its intensity depends by the output voltage and is controlled by the microprocessor on the Control Board.

The circuit determines the amount of current necessary to release the metal droplet that is being transferred from the electrode to the workpiece to guarantee the arc stability without going too high, to minimize the spatter levels. That means:

- Electrode to workpiece sticking prevention, even at low current values.
- Spatter reduction.

The welding operations are simplified and the welded joints look better, even if not brushed after the welding.

This feature is available in both the Soft Stick and Crisp Stick operating modes. The Crisp Stick feature also increases the Hot Start action, facilitating the arc striking.

The following features are also enabled in the stick welding modes:

- **Hot Start:** This is a temporary increase in the initial welding current. This helps ignite the arc quickly and reliably.
- **Anti-Sticking:** This is a function that decreases the output current of the machine to a low level when the operator makes an error and sticks the electrode to the work piece. This decrease in current allows the operator to remove the electrode from the electrode holder without creating large sparks that can damage the electrode holder.

FIGURE B.2

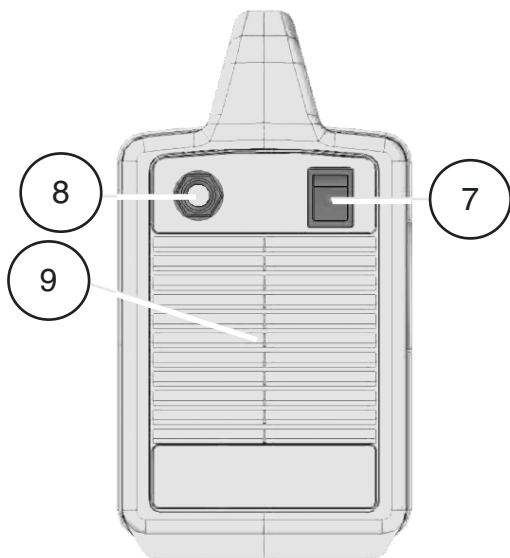

INVERTEC® V155-S



AccessoriesC-1

 Factory Installed OptionsC-2

 Field Installed OptionsC-2

 AccessoriesC-2

Return to Master TOC

Return to Master TOC

Return to Master TOC

Return to Master TOC

INVERTEC® V155-S



OPTIONAL ACCESSORIES AND COMPATIBLE EQUIPMENT

Factory Installed

Electrical Holder and Cable Assembly
Work Cable and Clamp
Strap Packet
Instruction Manual

Field Installed

PTA-17V TIG Torch - 150 Amp air-cooled compact and durable Tig Torch with integral gas valve for gas control at the torch. The following 1-piece cable torches can be used with a K960-2 adapter:

- K1782-6 (12.50 Ft.) 1-Piece Cable
- K1782-8 (25.0 Ft.) 1-Piece Cable

PTA-9FV TIG Torch - 125 Amp Gas Valve flexible head torch:

- K1781-7 (25.0 Ft.) 1-Piece Cable

PTA-17FV TIG Torch - 150 Amp Gas Valve flexible head torch:

- K1782-11 (25.0 Ft.) 1-Piece Cable
- K1782-13 (12.5 Ft.) 1-Piece Ultra Flex Cable

K960-2-TIG Torch Adapter - for connection of PTA-17V torches (1-piece cable) to power sources without gas passing through the Twist Mate connection.

CABLE PLUGS

K852-25 - Cable Plug Kit attaches to welding cable to provide quick disconnect from machine.

TIG Torch Parts Kits - Parts kits are available for the PTA-9FV and PTA-17 TIG torch. These kits include back cap, collets, collet bodies, nozzles and tungstens.

Order KP508 for PTA-17 torches

Order KP507 for PTA-9 torches

See publication E12.150 for parts kits breakdown.

Cut Length Consumables - TIG welding filler metals are available for welding stainless steel, mild steel, aluminum and copper alloys. See publication C9.10.

MaintenanceD-1

Safety PrecautionsD-2

Routine MaintenanceD-2

Thermal ProtectionD-2

Return to Master TOC

Return to Master TOC

Return to Master TOC

Return to Master TOC

SAFETY PRECAUTIONS

⚠ WARNING



ELECTRIC SHOCK can kill.

- Have an electrician install and service this equipment.
- Turn the input power off at the fuse box, disconnect supply lines and allow machine to sit for five minutes minimum to allow the power capacitors to discharge before working inside this equipment.
- Do not touch electrically hot parts.

INPUT FILTER CAPACITOR DISCHARGE PROCEDURE

⚠ WARNING

For any maintenance or repair operations it is recommended to contact the nearest technical service center or Lincoln Electric. Maintenance or repairs performed by unauthorized service centers or personnel will null and void the manufacturers warranty.

⚠ WARNING

The machine has internal capacitors which are charged to a high voltage during power-on conditions. This voltage is dangerous and must be discharged before the machine can be serviced. Discharging is done automatically by the machine each time the power is switched off. However, you must allow the machine to sit for at least 5 minutes to allow time for the process to take place.

ROUTINE MAINTENANCE

The frequency of the maintenance operations may vary in accordance with the working environment. Any noticeable damage should be reported immediately.

- Check cables and connections integrity. Replace, if necessary.
- Clean the power source inside by means of low - pressure compressed air.
- Keep the machine clean. Use a soft dry cloth to clean the external case, especially the airflow inlet / outlet louvers.

⚠ WARNING

Do not open this machine and do not introduce anything into its openings. Power supply must be disconnected from the machine before each maintenance and service. After each repair, perform proper tests to ensure safety.

⚠ CAUTION

Power supply must be disconnected from the machine before each maintenance and service. Always use gloves in compliance with the safety standards.

THERMAL PROTECTION

The V155-S has a thermal,protective device (PTC) on the Output Rectifier to protect against excessive dirty cycle. It also has an auto resetting fuse (ARFU) on the Input Board to protect against incorrect line voltage when connected to 120VAC. If either device opens, the Thermal LED on the front panel will turn ON. See the Operarion Section or the Troubleshooting Section of this manual for corrective action.

MAJOR COMPONENT LOCATIONS

- | | |
|---|--|
| <ol style="list-style-type: none"> 1. Front Panel 2. Right Case Side 3. Left Case Side 4. Rear Panel 5. Fan 6. Cable Clamp 7. Input Cable 8. ON/OFF Switch 9. Input P.C. Board | <ol style="list-style-type: none"> 10. Inverter P.C. Board 11. Control P.C. Board 12. Knob 13. Output Connector 14. Carrying Strap * 15. Nameplate * 16. Side Decal Set * <p style="margin-top: 10px;">* Not in picture</p> |
|---|--|

FIGURE D.1 - MAJOR COMPONENT LOCATIONS

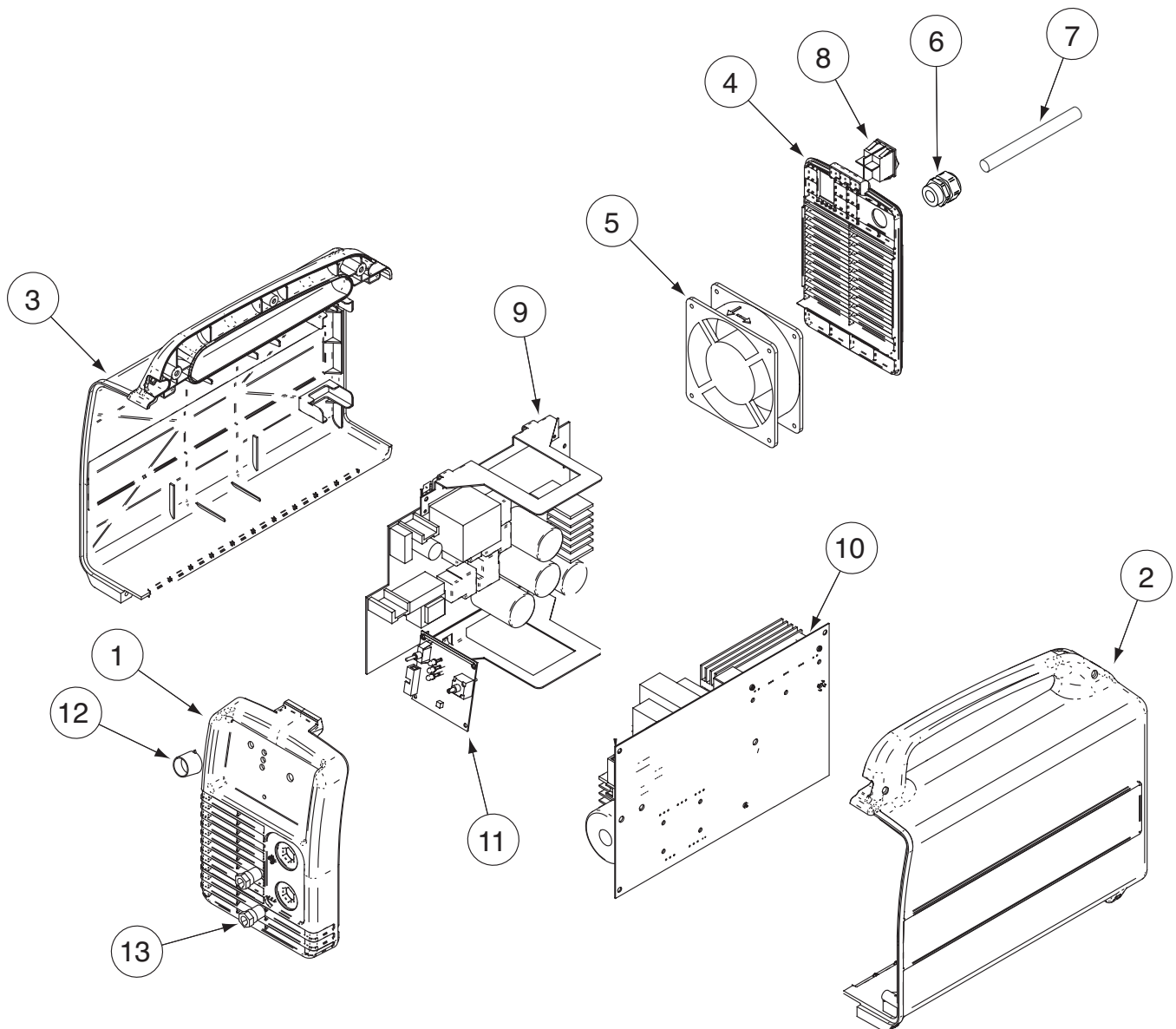

INVERTEC® V155-S



Return to Section TOC
Return to Master TOC
Return to Section TOC
Return to Master TOC
Return to Section TOC
Return to Master TOC
Return to Section TOC
Return to Master TOC
Return to Section TOC
Return to Master TOC

INVERTEC® V155-S



Theory of OperationE-1

General DescriptionE-2

Input BoardE-3

Main IGBT Inverter BoardE-4

Main TransformerE-4

Control BoardE-5

Insulated Gate Bipolar Transistor (IGBT) OperationE-6

Pulse Width ModulationE-7

FIGURE E.1 – BLOCK LOGIC DIAGRAM.

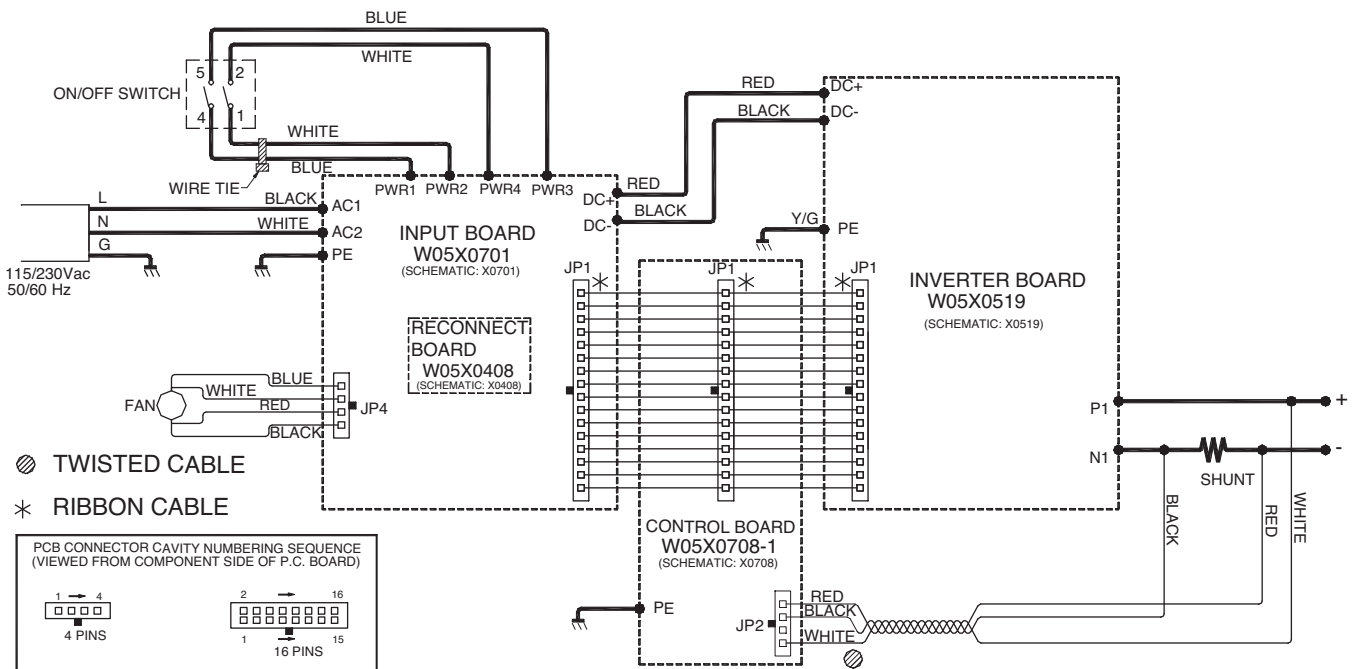
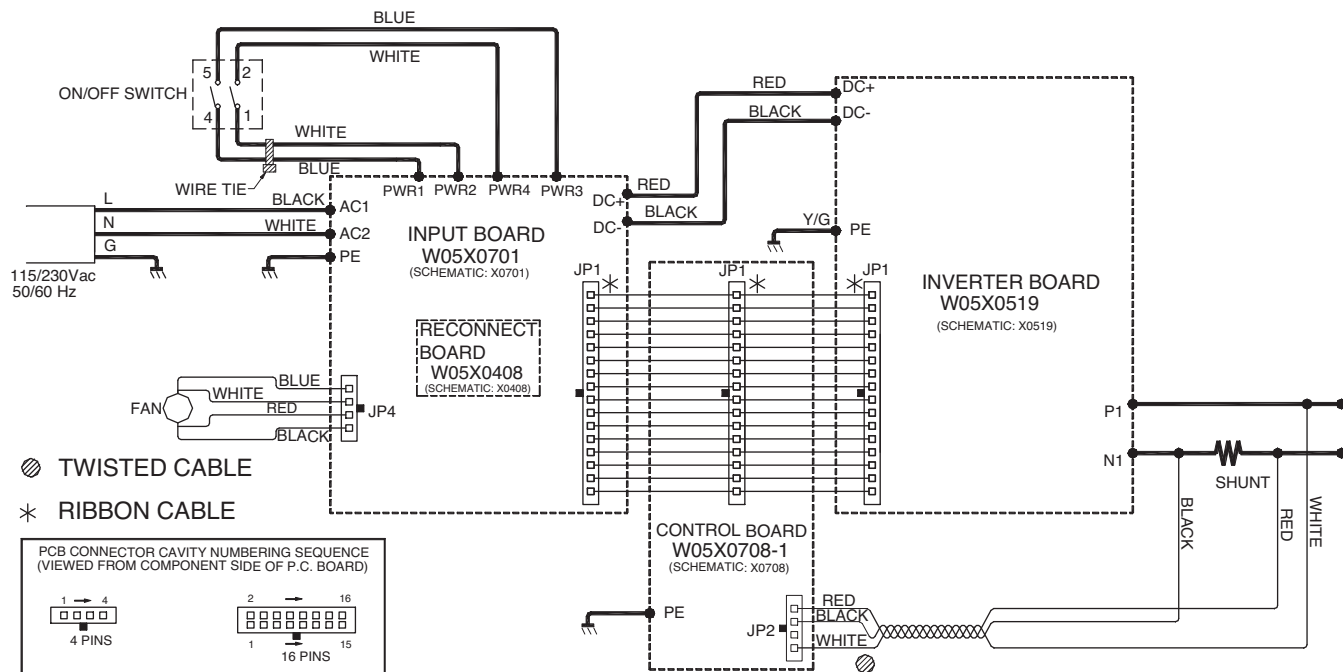

FIGURE E.2 — GENERAL DESCRIPTION



GENERAL DESCRIPTION

The INVERTEC® V155-S is an industrial 155 amp arc welding power source which utilizes single phase input power, to produce constant current output. The welding response of this Invertec has been optimized for stick (SMAW) and Touch Start TIG (GTAW). The unit is ideal for industrial applications where portability is important.

The INVERTEC® V155-S is recommended for stick welding with such popular electrodes as Fleetweld 35, Fleetweld 37, Fleetweld 180 and LH 78. It features automatic arc control to adjust the arc force, hot start and anti sticking. The machine also features soft and crisp modes.

The INVERTEC® V155-S performs DC Touch Start Tig starting with excellent results.

The INVERTEC® V155-S is rated at 155 amps, 16.2 volts, at 30% duty cycle on a ten minute basis. It is capable of higher duty cycles at lower output currents. It is capable of 105 amps, 14.2 volts at 100% duty cycle. If the duty cycle is exceeded, a thermal protector will shut off the output until the machine cools. See Technical Specifications in A-1 for other rated outputs.

the INVERTEC® V155-S is recommended for stick welding with such popular electrodes as Fleetweld® 35, Fleetweld 37, Fleetweld 180 and Jet-LH 78MR. It features adjustable arc control to adjust the arc force and start.

LIMITATIONS

The INVERTEC® V155-S is not recommended for pipe thawing.

NOTE: Unshaded areas of Block Logic Diagram are the subject of discussion

INVERTEC® V155-S



FIGURE E.3 – INPUT BOARD

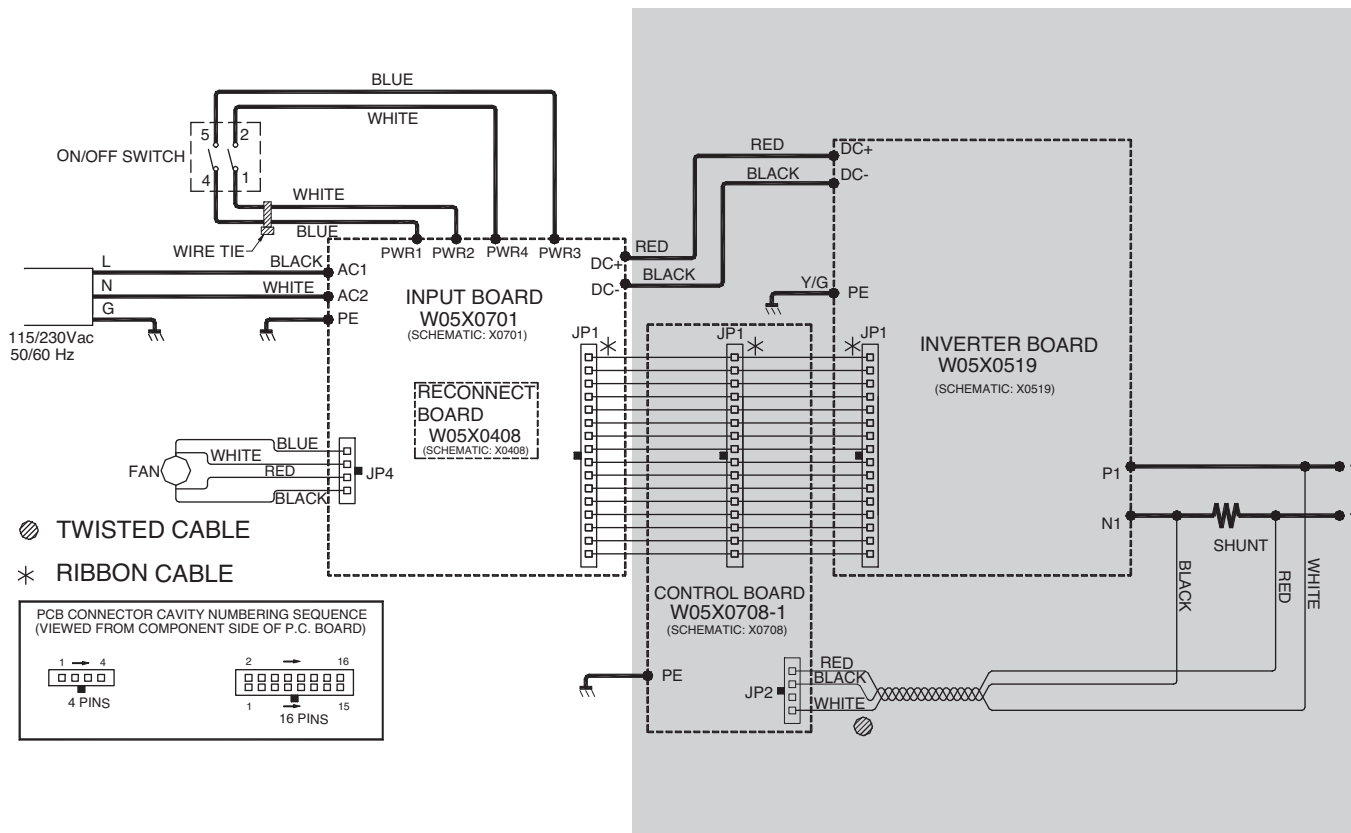

INPUT BOARD

The Input Board includes the following circuits:

- **Automatic Reconnect Circuit:** This circuit monitors the input voltage and automatically reconnects the inverter and auxiliary connections to configure the machine for either 115V or 230V ac input voltage. The proper configuration is achieved through the use of board mounted relays. These relays and others that activate the Pre-charge circuitry and the fan circuit are controlled through signals from a micro-processor on the board.
- **Switching Power Supply:** Supplied by a board mounted transformer, the switching power supply provides +15 vdc and +5vdc supplies for use on all of the PC Boards.
- **Input Rectifier and Precharge Circuit:** The Pre-charge rectifier and current limiting resistors apply a small charge to the filter capacitors when the Power Switch is turned ON.
- **Auto Reset Fuse:** A self resetting fuse circuit (ARFU) on the Input Board helps to prevent damage to the machine from over-current when in 120VAC operation. When the fuse is open, the output will be disabled and the yellow Temperature LED on the front panel will be ON.
- An improper input voltage would be recognized during this time and an input error sent to the Control Board. A signal from the Control Board would prevent further power-up to prevent damage to the Inverter Board.
- The re-connect relays then apply full power from the input line (AC1 and AC2) to the Input Rectifier and the capacitors are fully charged to approximately 325VDC. (See the Machine Diagram and PC Board Schematics for more information).

NOTE: Unshaded areas of Block Logic Diagram are the subject of discussion

INVERTEC® V155-S



FIGURE E.4 — MAIN INVERTER BOARD

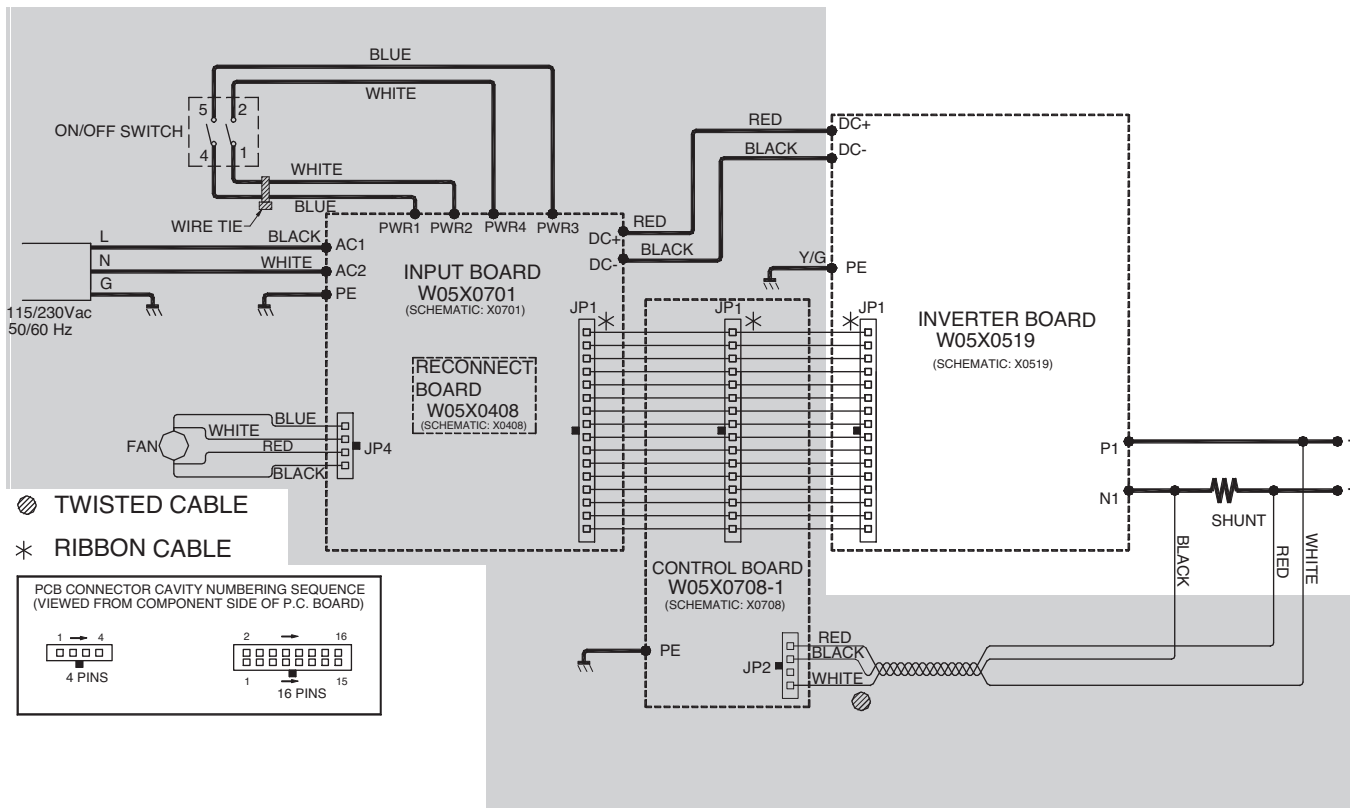

MAIN INVERTER BOARD

The Inverter Board includes the following circuits:

- **Inverter Circuit:** Through the use of Insulated Gate Bipolar Transistors (IGBT's) the high voltage (325VDC) input current is switched ON and OFF at a frequency of 80KHz and fed to the primary of the main transformer. The current is regulated via Pulse Width Modulation (PWM). The width of each pulse is determined by a 'gate' signal from the Control Board. (See **IGBT Operation** and **Pulse Width Modulation** in this section).
- **Main Transformer:** The primary function of the main transformer is to reduce the high voltage 80khz output to the proper voltage for welding. It also serves to insulate the operator from the input line. Additional windings of the transformer provide both primary and secondary feedback signals to the PWM control circuit.

- **Output Circuit:** The output diodes and the output choke rectify and filter the current from the secondary of the main transformer to make it acceptable for welding. The shunt provides the necessary current feedback information to the Control Board.

Note: The shunt is shown off the board for clarity. It is actually mounted on the Inverter Board.

FIGURE E.5 — CONTROL BOARD

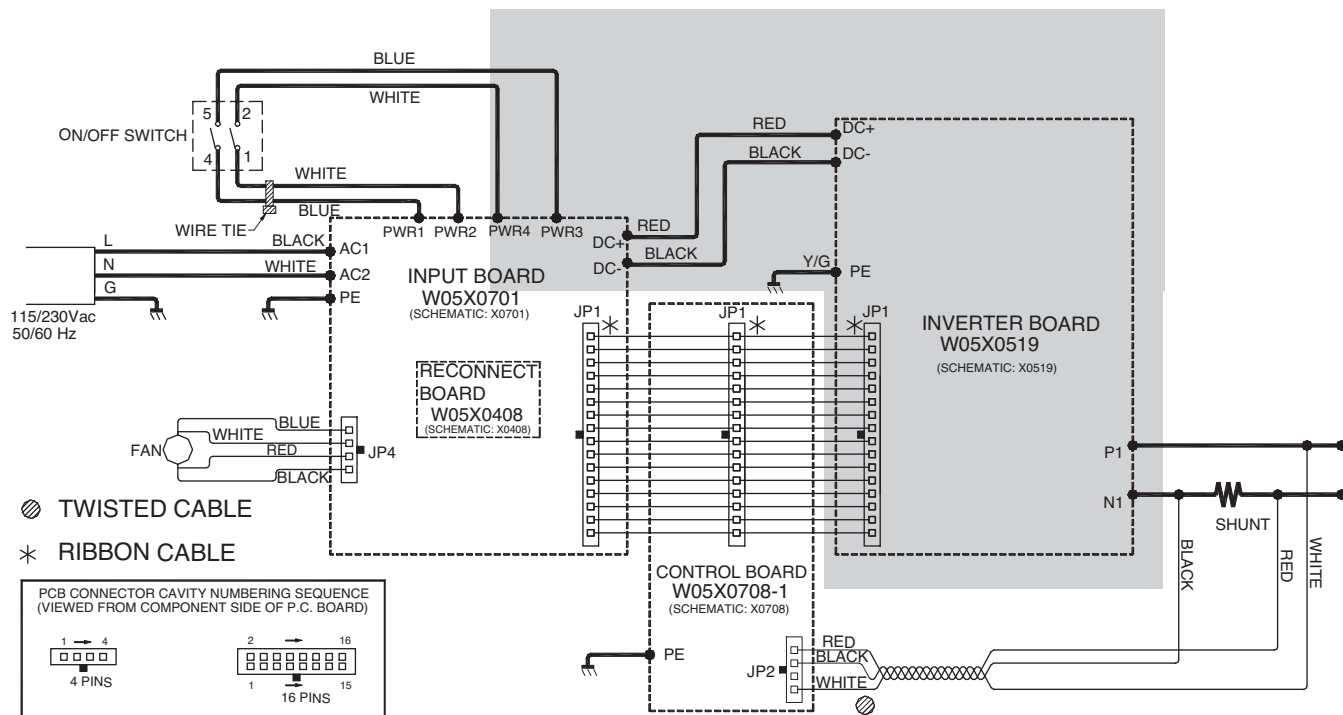

CONTROL BOARD

The Control Board receives status and analogue signals from the inverter board, input board and various sensors and feeds this information to the Weld Controller.

The Weld Controller is a micro-processor that uses these signals along with input from the Mode Switch and the Control Potentiometer to make decisions and change the machine mode and output to satisfy the requirements as decided by the operator. These changes are relayed to the PWM circuit on the Inverter Board to regulate the gate signals to the IGBT's

The Weld Controller also responds to thermal and input errors to shut down the machine output. The error information is then displayed by the three LED's on the front panel.

The Mode Switch, the Control Potentiometer and the three LED's are all mounted on the Control Board.

FIGURE E.6 – IGBT OPERATION

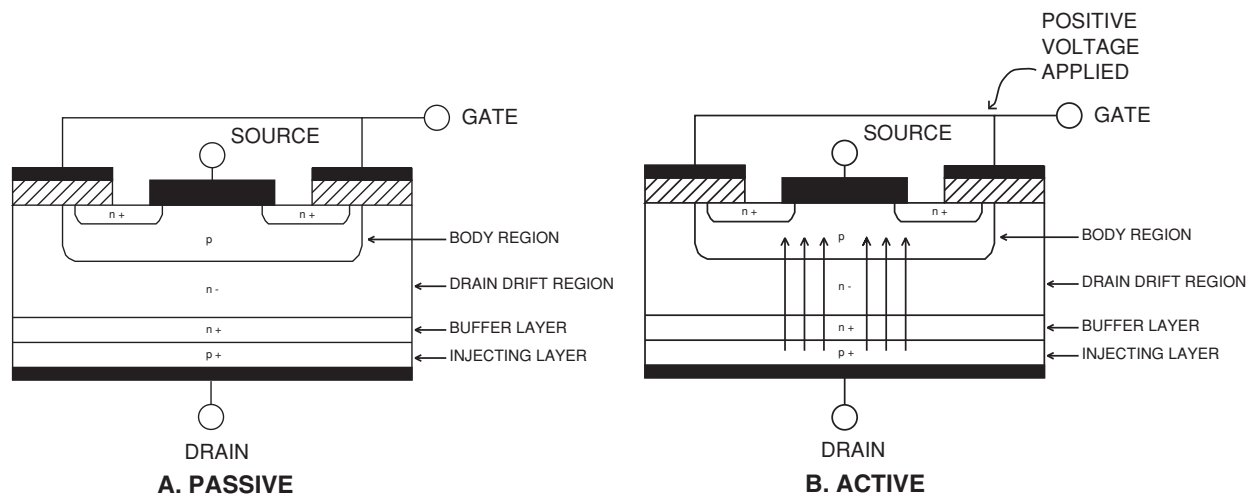

INSULATED GATE BIPOLAR TRANSISTOR (IGBT) OPERATION

An IGBT is a type of transistor. IGBTs are semiconductors well suited for high frequency switching and high current applications.

Drawing A shows an IGBT in a passive mode. There is no gate signal, zero volts relative to the source, and therefore, no current flow. The drain terminal of the IGBT may be connected to a voltage supply; but since there is no conduction the circuit will not supply current to components connected to the source. The circuit is turned off like a light switch in the OFF position.

Drawing B shows the IGBT in an active mode. When the gate signal, a positive DC voltage relative to the source, is applied to the gate terminal of the IGBT, it is capable of conducting current. A voltage supply connected to the drain terminal will allow the IGBT to conduct and supply current to circuit components coupled to the source. Current will flow through the conducting IGBT to downstream components as long as the positive gate signal is present. This is similar to turning ON a light switch.

Figure E-7

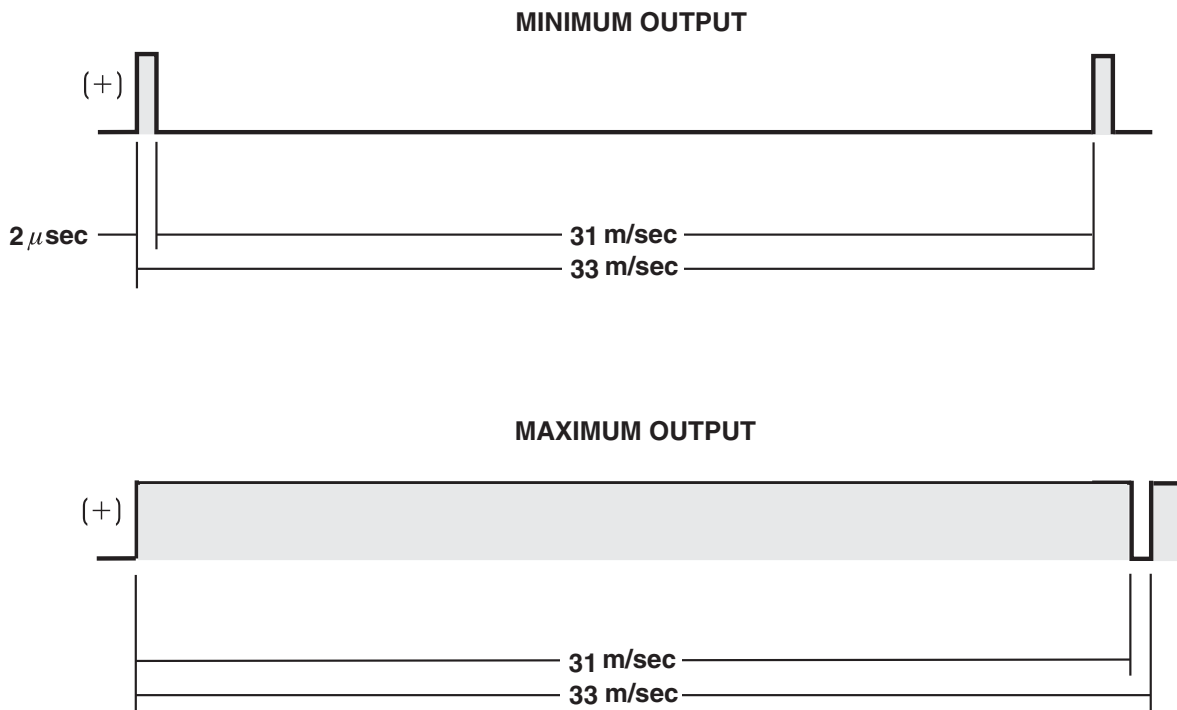

PULSE WIDTH MODULATION

The term PULSE WIDTH MODULATION is used to describe how much time is devoted to conduction in the cycle. Changing the pulse width is known as MODULATION. Pulse Width Modulation (PWM) is the varying of the pulse width over the allowed range of a cycle to affect the output of the machine.

MINIMUM OUTPUT

By controlling the duration of the gate signal, the IGBT is turned on and off for different durations during a cycle. The top drawing shows the minimum output signal possible over a 33-microsecond time period.

The shaded portion of the signal represents the IGBT, conducting for 2 microseconds. Since only 2 microseconds of the 33-microsecond time period is devoted to conducting, the output power is minimized.

MAXIMUM OUTPUT

By holding the gate signals on for 31 microseconds and allowing only 2 microseconds of off time during the 33 microsecond cycle, the output is maximized. The darkened area under the min. curve can be compared to the darkened area under the max. curve. The more darkened area, the more power is present.

Return to Section TOC

Return to Section TOC

Return to Section TOC

Return to Section TOC

Return to Master TOC

Return to Master TOC

Return to Master TOC

Return to Master TOC

INVERTEC® V155-S



Troubleshooting and Repair	F-1
How to Use Troubleshooting Guide	F-2
PC Board Troubleshooting Procedures	F-3
Troubleshooting Guide	F-4
Case Cover Removal Procedure	F-7
Input Filter Capacitor Discharge Procedure	F-9
Input Board Resistance Test	F-13
Inverter Board Resistance Test	F-15
Input Board Voltage Test	F-19
Inverter Board Voltage Test	F-23
Input Board Removal and Replacement	F-25
Inverter Board Removal and Replacement	F-27
Control Board Removal and Replacement	F-31
Retest After Repair	F-33

HOW TO USE TROUBLESHOOTING GUIDE

⚠ WARNING

Service and Repair should only be performed by Lincoln Electric Factory Trained Personnel. Unauthorized repairs performed on this equipment may result in danger to the technician and machine operator and will invalidate your factory warranty. For your safety and to avoid Electrical Shock, please observe all safety notes and precautions detailed throughout this manual.

This Troubleshooting Guide is provided to help you locate and repair possible machine malfunctions. Simply follow the three-step procedure listed below.

Step 1. LOCATE PROBLEM (SYMPTOM).

Look under the column labeled "PROBLEM (SYMPTOMS)". This column describes possible symptoms that the machine may exhibit. Find the listing that best describes the symptom that the machine is exhibiting. Symptoms are grouped into the following categories: output problems, function problems, wire feeding problems, and welding problems.

Step 2. PERFORM EXTERNAL TESTS.

The second column labeled "POSSIBLE AREAS OF MISADJUSTMENT(S)" lists the obvious external possibilities that may contribute to the machine symptom. Perform these tests/checks in the order listed. In general, these tests can be conducted without removing the case wrap-around cover.

Step 3. RECOMMENDED COURSE OF ACTION

The last column labeled "Recommended Course of Action" lists the most likely components that may have failed in your machine. It also specifies the appropriate test procedure to verify that the subject component is either good or bad. If there are a number of possible components, check the components in the order listed to eliminate one possibility at a time until you locate the cause of your problem.

All of the referenced test procedures referred to in the Troubleshooting Guide are described in detail at the end of this chapter. Refer to the Troubleshooting and Repair Table of Contents to locate each specific Test Procedure. All of the specified test points, components, terminal strips, etc. can be found on the referenced electrical wiring diagrams and schematics. Refer to the Electrical Diagrams Section Table of Contents to locate the appropriate diagram.

⚠ CAUTION

If for any reason you do not understand the test procedures or are unable to perform the tests/repairs safely, contact the Lincoln Electric Service Department for technical troubleshooting assistance before you proceed. Call 1-888-935-3877.

PC BOARD TROUBLESHOOTING PROCEDURES

WARNING**ELECTRIC SHOCK
can kill.**

- Have an electrician install and service this equipment. Turn the input power OFF at the fuse box before working on equipment. Do not touch electrically hot parts.

CAUTION

Sometimes machine failures appear to be due to PC board failures. These problems can sometimes be traced to poor electrical connections. To avoid problems when troubleshooting and replacing PC boards, please use the following procedure:

1. Determine to the best of your technical ability that the PC board is the most likely component causing the failure symptom.
2. Check for loose connections at the PC board to assure that the PC board is properly connected.
3. If the problem persists, replace the suspect PC board using standard practices to avoid static electrical damage and electrical shock. Read the warning inside the static resistant bag and perform the following procedures:

PC board can be damaged by static electricity.

- Remove your body's static charge before opening the static-shielding bag. Wear an anti-static wrist strap. For safety, use a 1 Meg ohm resistive cord connected to a grounded part of the equipment frame.

- If you don't have a wrist strap, touch an un-painted, grounded, part of the equipment frame. Keep touching the frame to prevent static build-up. Be sure not to touch any electrically live parts at the same time.

- Tools which come in contact with the PC board must be either conductive, anti-static or static-dissipative.

- Remove the PC board from the static-shielding bag and place it directly into the equipment. Don't set the PC board on or near paper, plastic or cloth which could have a static charge. If the PC board can't be installed immediately, put it back in the static-shielding bag.
- If the PC board uses protective shorting jumpers, don't remove them until installation is complete.
- If you return a PC board to The Lincoln Electric Company for credit, it must be in the static-shielding bag. This will prevent further damage and allow proper failure analysis.

4. Test the machine to determine if the failure symptom has been corrected by the replacement PC board.

NOTE: It is desirable to have a spare (known good) PC board available for PC board troubleshooting.

NOTE: Allow the machine to heat up so that all electrical components can reach their operating temperature.

5. Remove the replacement PC board and substitute it with the original PC board to recreate the original problem.
 - a. If the original problem does not reappear by substituting the original board, then the PC board was not the problem. Continue to look for bad connections in the control wiring harness, junction blocks, and terminal strips.
 - b. If the original problem is recreated by the substitution of the original board, then the PC board was the problem. Reinstall the replacement PC board and test the machine.
6. Always indicate that this procedure was followed when warranty reports are to be submitted.

NOTE: Following this procedure and writing on the warranty report, "INSTALLED AND SWITCHED PC BOARDS TO VERIFY PROBLEM," will help avoid denial of legitimate PC board warranty claims.

Observe Safety Guidelines detailed in the beginning of this manual.

PROBLEMS (SYMPTOMS)	POSSIBLE AREAS OF MISADJUSTMENT(S)	RECOMMENDED COURSE OF ACTION
OUTPUT PROBLEMS		
The line circuit breaker trips when power switch is "ON"	<ol style="list-style-type: none"> 1. Input power Bridge is shorted. 2. Failed Electrolytic Capacitors. 3. Failed Inverter IGBT's. 	<ol style="list-style-type: none"> 1. Perform the <i>Input Board Resistance Test.</i> 2. Perform the <i>Inverter Board Resistance Test.</i>
The machine is dead, no output, no fan	<ol style="list-style-type: none"> 1. No input power on line. 2. Line Switch failure. 3. Defective Input Board. 4. Defective Inverter Board 	<ol style="list-style-type: none"> 1. Restore correct Input power 2. Replace Line switch. 3. Perform <i>Input Board Voltage Test.</i> 4. Perform <i>Inverter Board Voltage Test.</i>
<p>The GREEN LED is "ON" but there is no output And yellow thermal overload LED is "ON"</p> <p>The YELLOW LED is "ON" and the RED and GREEN LED's blink alternately</p>	<ol style="list-style-type: none"> 1. Thermal Protection has tripped. 2. Logic Circuit Error on Control Board. 3. ARFU System Damage on the Input Board <ol style="list-style-type: none"> 1. The machine is unable to cool itself. 	<ol style="list-style-type: none"> 1. Check Fan and Thermal Protection Circuits. 2. Perform <i>Input Board Resistance</i> and <i>Input Board Voltage Tests</i> 3. The Control Board may be faulty. Replace. <ol style="list-style-type: none"> 1. Turn the Power Switch OFF and wait several minutes for the machine to cool. Turn the Power Switch back ON and check for proper fan operation.

⚠ CAUTION

If for any reason you do not understand the test procedures or are unable to perform the tests/repairs safely, contact the Lincoln Electric Service Department for technical troubleshooting assistance before you proceed. Call 1-888-935-3877.

INVERTEC® V155-S



Observe Safety Guidelines detailed in the beginning of this manual.

PROBLEMS (SYMPTOMS)	POSSIBLE AREAS OF MISADJUSTMENT(S)	RECOMMENDED COURSE OF ACTION
OUTPUT PROBLEMS		
RED and GREEN LED's are always "ON"	1. Control Board failure.	1. Check all PC Board Connections. 2. Replace Control Board.
The machine welds but there is no output control	1. Potentiometer failure. 2. The Shunt screw connections are bad. 3. Inverter Board failure.	1. Potentiometer or Control Board needs Replaced. 2. Tighten and check all shunt connections. 3. Perform <i>Inverter Board Voltage Test.</i>
The machine does not have maximum output	1. Loose connections on output secondary leads. 2. The Control Board is out of Calibration.	1. Check all secondary connections. 2. Recalibrate the Control Board. Replace if needed.

⚠ CAUTION

If for any reason you do not understand the test procedures or are unable to perform the tests/repairs safely, contact the Lincoln Electric Service Department for technical troubleshooting assistance before you proceed. Call 1-888-935-3877.

INVERTEC® V155-S



Observe Safety Guidelines detailed in the beginning of this manual.

PROBLEMS (SYMPTOMS)	POSSIBLE AREAS OF MISADJUSTMENT(S)	RECOMMENDED COURSE OF ACTION
OUTPUT PROBLEMS		
The machine has high welding output and no control	<ol style="list-style-type: none"> Potentiometer failure. Control Board failure. 	<ol style="list-style-type: none"> Replace Potentiometer. Replace Control Board.
RED LED stays ON continuously	<ol style="list-style-type: none"> Shunt Cable damaged. Control Board defective. 	<ol style="list-style-type: none"> Check connection of white, red and black leads on the Inverter Board Replace Shunt Cable Assembly. Replace Control Board.
Flashing YELLOW LED	<ol style="list-style-type: none"> Input Supply Voltage out of tolerance. 	<ol style="list-style-type: none"> Supply correct Input Voltage. Check Control Board connections.

⚠ CAUTION

If for any reason you do not understand the test procedures or are unable to perform the tests/repairs safely, contact the Lincoln Electric Service Department for technical troubleshooting assistance before you proceed. Call 1-888-935-3877.

INVERTEC® V155-S



TROUBLESHOOTING & REPAIR

CASE COVER REMOVAL PROCEDURE

WARNING

Service and repair should be performed by only Lincoln Electric factory trained personnel. Unauthorized repairs performed on this equipment may result in danger to the technician or machine operator and will invalidate your factory warranty. For your safety and to avoid electrical shock, please observe all safety notes and precautions detailed throughout this manual.

If for any reason you do not understand the test procedures or are unable to perform the test/repairs safely, contact the Lincoln Electric Service Department for electrical troubleshooting assistance before you proceed. Call 1-888-935-3877.

TEST DESCRIPTION

This procedure will aid the technician in the removal and replacement of the case cover(s).

MATERIALS NEEDED

8" Magnetized #2 Phillips Head Screwdriver or
Socket with Magnetized 6 inch Extension and #2 Phillips Tip

INVERTEC® V155-S



CASE COVER REMOVAL PROCEDURE (CONTINUED)

FIGURE F.1 – CASE COVER SCREW LOCATIONS

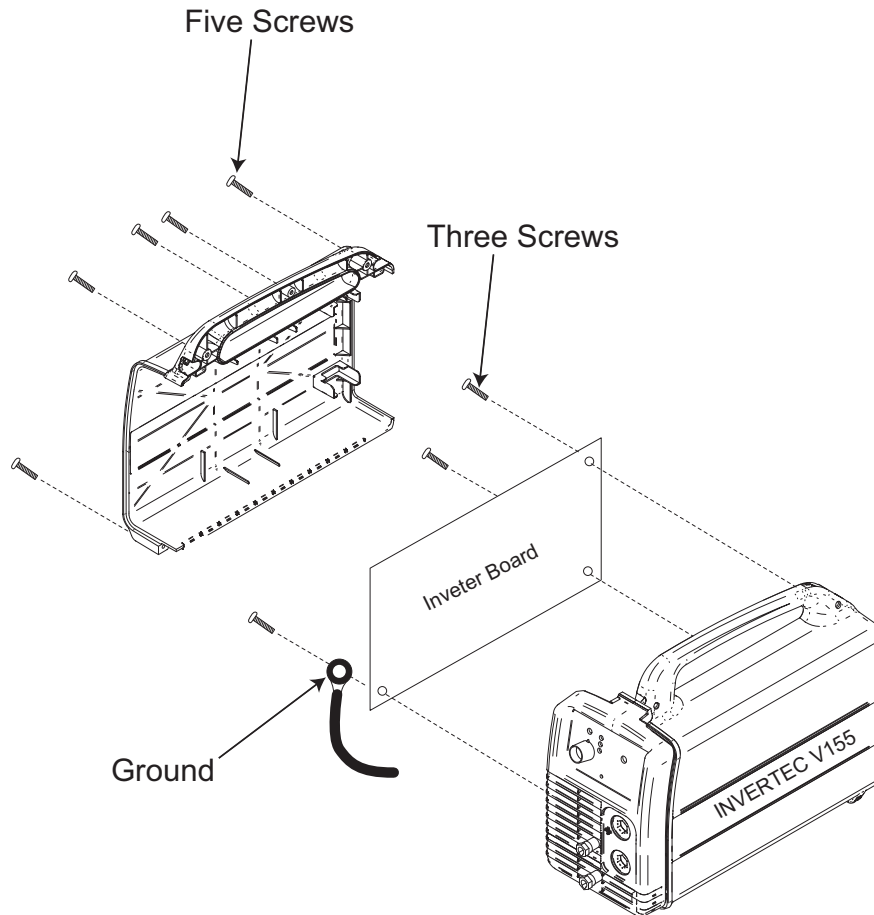

PROCEDURE

1. Disconnect power to the INVERTEC® V155-S.
2. Using a phillips head screwdriver remove the five screws securing the case cover sides together. See Figure F.1.

Note: The two bottom screws are machine screws that thread into nuts. The nuts will fall out of the right side.

3. Carefully remove the left side case cover from the machine.

Note: Be careful. The case back and fan will be loose when the cover is removed.

4. Perform the *Input Capacitor Discharge Procedure steps 3 thru 7*.

5. Using a phillips screwdriver, remove the three screws securing the Inverter board to the right side case cover.

Note: These screws can only be accessed from the inside of the machine and only after the left side case cover has been removed. It may be necessary to cut the plastic tie that secures the Input power cord to the top bracket

6. Note placement of ground lead secured by lower front phillips screw on inverter board for re-assembly.
7. Remove case back and fan. Lay unit on the left side and remove the right side cover.

INVERTEC® V155-S



INPUT FILTER CAPACITOR DISCHARGE PROCEDURE

WARNING

Service and repair should be performed by only Lincoln Electric factory trained personnel. Unauthorized repairs performed on this equipment may result in danger to the technician or machine operator and will invalidate your factory warranty. For your safety and to avoid electrical shock, please observe all safety notes and precautions detailed throughout this manual.

If for any reason you do not understand the test procedures or are unable to perform the test/repairs safely, contact the Lincoln Electric Service Department for electrical troubleshooting assistance before you proceed. Call 1-888-935-3877.

TEST DESCRIPTION

This procedure will drain off any charge stored in the four capacitors that are part of the Inverter Board assembly. This procedure **MUST** be performed, as a safety precaution, before conducting any test or repair procedure that requires you to touch internal components of the machine.

MATERIALS NEEDED

- Phillips Head Screwdriver
- High Resistance and High Wattage Resistor (25-1000 ohms and 25 watts minimum)
- Insulated Gloves
- Insulated Pliers

INPUT FILTER CAPACITOR DISCHARGE PROCEDURE (CONTINUED)

FIGURE F.2 – CAPACITOR DISCHARGE LOCATIONS

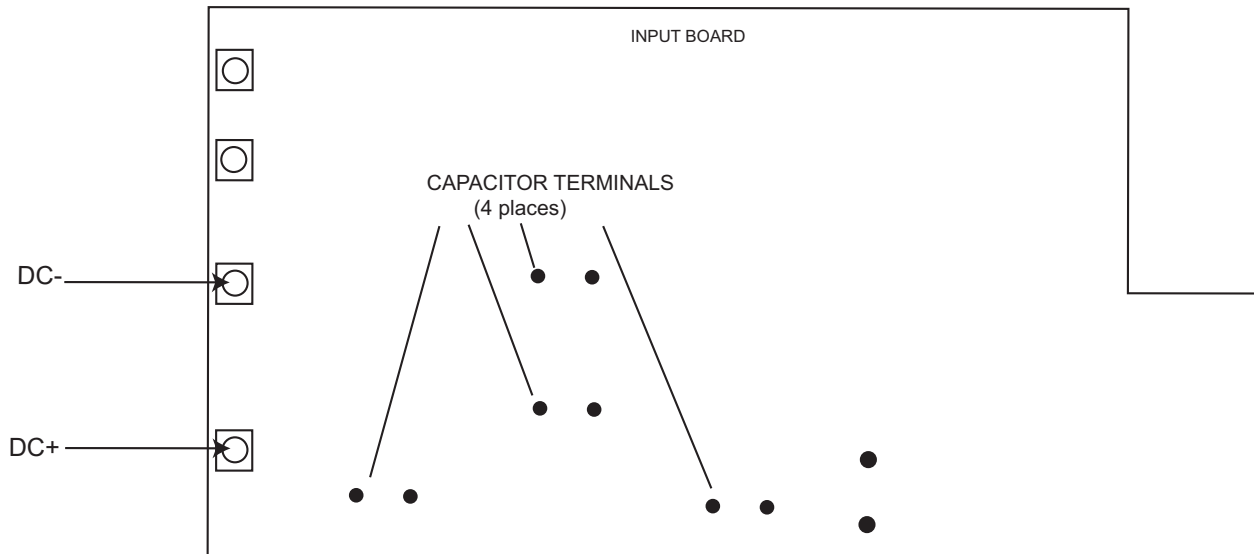

WARNING



ELECTRIC SHOCK can kill.

- Have an electrician install and service this equipment.
- Turn the input power off at the fuse box before working on equipment.
- Do not touch electrically hot parts.
- Prior to performing preventative maintenance, perform the following capacitor discharge procedure to avoid electric shock.

PROCEDURE

1. Disconnect power to the INVERTEC® V155-S.
2. Perform the **Case Cover Removal Procedure, steps 1 thru 3.**
3. Locate the Input Board.
4. Obtain a high resistance and high wattage resistor (25-1000 ohms and 25 watts minimum). This resistor is NOT supplied with the machine. NEVER USE A SHORTING STRAP FOR THIS PROCEDURE.
5. Locate the two terminals DC+ and DC- on the Input Board. See Figure F.2.
6. Use electrically insulated gloves and insulated pliers. Hold the body of the resistor and connect the resistor leads across the two terminals. Hold the resistor in place for 10 seconds. DO NOT TOUCH CAPACITOR TERMINALS WITH YOUR BARE HANDS. See Figure F.3.
7. Check the voltage across the terminals of all capacitors with a DC voltmeter. Voltage should be zero. If any voltage remains, repeat this capacitor discharge procedure.

FIGURE F.3 – GLOVE, PLIERS & RESISTOR

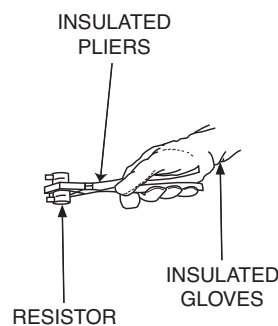

INVERTEC® V155-S



INPUT FILTER CAPACITOR DISCHARGE PROCEDURE (CONTINUED)

FIGURE F.4 – CAPACITOR DISCHARGE LOCATIONS

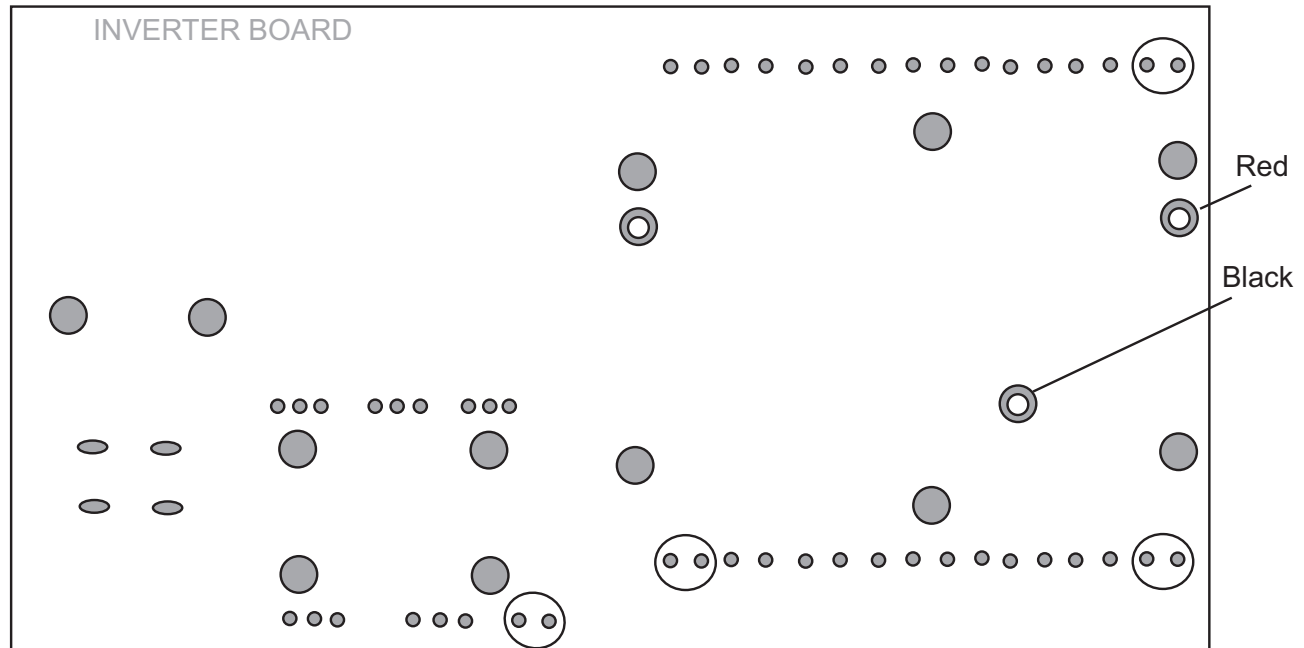

8. Remove the right side cover per **Case Cover Removal Procedure steps 5 thru 7**.
9. Use electrically insulated gloves and insulated pliers. Hold the body of the resistor and connect the resistor leads across the two terminals where the RED and BLACK leads are connected. Hold the resistor in place for 10 seconds. DO NOT TOUCH CAPACITOR TERMINALS WITH YOUR BARE HANDS. See **Figures F.3** and F.4
10. Check the voltage across the terminals with a DC voltmeter. Voltage should be zero. If any voltage remains, repeat this capacitor discharge procedure.

Return to Section TOC
Return to Master TOC
Return to Section TOC
Return to Master TOC
Return to Section TOC
Return to Master TOC
Return to Section TOC
Return to Master TOC
Return to Section TOC
Return to Master TOC

INVERTEC® V155-S



INPUT BOARD RESISTANCE TEST**⚠ WARNING**

Service and repair should be performed by only Lincoln Electric factory trained personnel. Unauthorized repairs performed on this equipment may result in danger to the technician or machine operator and will invalidate your factory warranty. For your safety and to avoid electrical shock, please observe all safety notes and precautions detailed throughout this manual.

If for any reason you do not understand the test procedures or are unable to perform the test/repairs safely, contact the Lincoln Electric Service Department for electrical troubleshooting assistance before you proceed. Call 1-888-935-3877.

TEST DESCRIPTION

This procedure will determine if the Input Board has any copper wires burned or any faulty components.

MATERIALS NEEDED

Volt/Ohmmeter
Wiring Diagram W05X0701
Phillips Screwdriver

INPUT BOARD RESISTANCE TEST (*CONTINUED*)

FIGURE F.5 – INPUT BOARD TEST POINTS

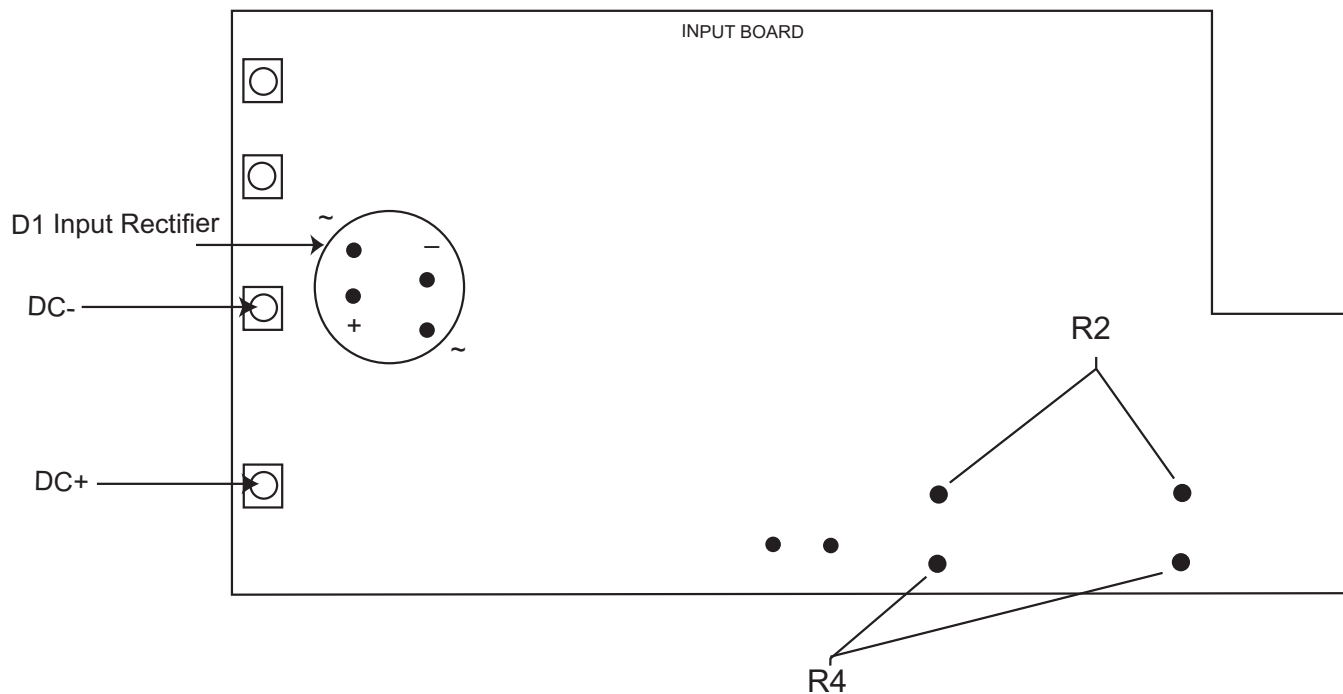
**PROCEDURE**

1. Disconnect power to the INVERTEC® V155-S.
2. Perform the ***Case Cover Removal Procedure***.
3. Perform the ***Input Filter Capacitor Discharge Procedure***.
4. Visually check for burned areas on The Input Board (solder side).
5. Disconnect the Black lead from the DC- terminal.
6. Check the Input Rectifier Bridge "D1".
7. Check start resistors "R2" and "R4". Each should read 20 Ohms. See Figure F.5.

TROUBLESHOOTING & REPAIR

INVERTER BOARD RESISTANCE TEST

WARNING

Service and repair should be performed by only Lincoln Electric factory trained personnel. Unauthorized repairs performed on this equipment may result in danger to the technician or machine operator and will invalidate your factory warranty. For your safety and to avoid electrical shock, please observe all safety notes and precautions detailed throughout this manual.

If for any reason you do not understand the test procedures or are unable to perform the test/repairs safely, contact the Lincoln Electric Service Department for electrical troubleshooting assistance before you proceed. Call 1-888-935-3877.

TEST DESCRIPTION

This procedure will determine if the Inverter Board has any “shorted” or “leaky” power diodes or Insulated Gate Bipolar Transistors.

MATERIALS NEEDED

Digital Volt/Ohmmeter
Wiring Diagram X0519
Phillips Screwdriver
4mm Nutdriver

INVERTEC® V155-S



INVERTER BOARD RESISTANCE TEST (CONTINUED)

FIGURE F.6 – INVERTER BOARD TEST POINTS

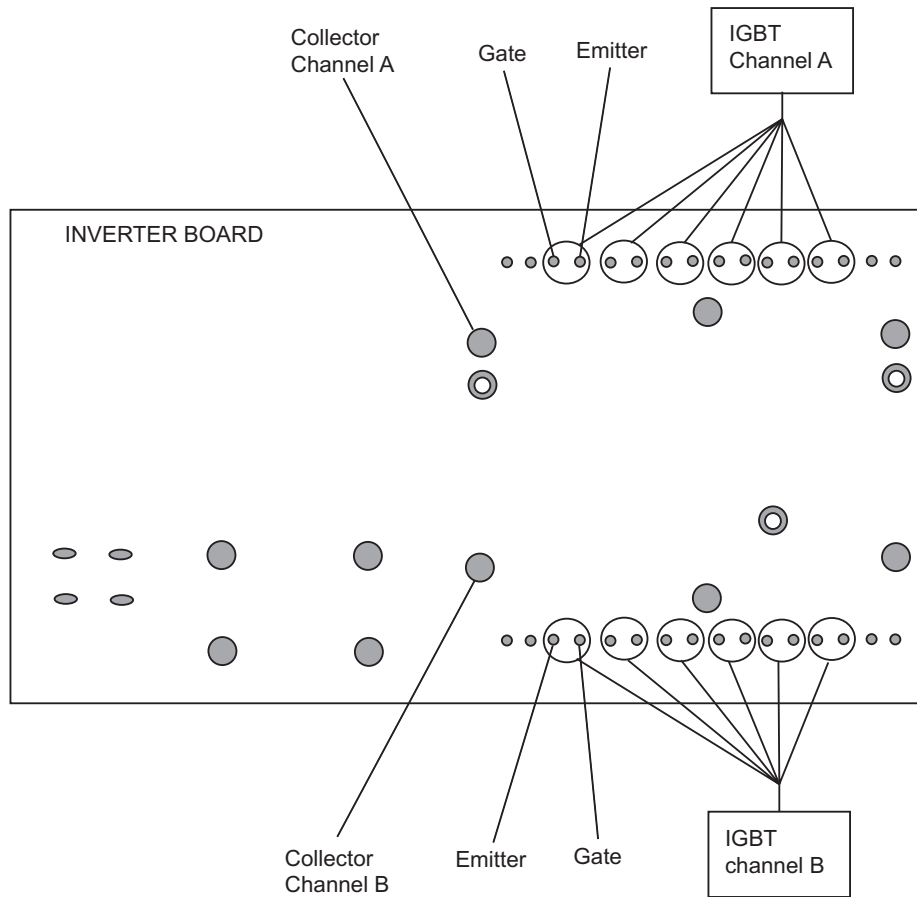

PROCEDURE

1. Disconnect power to the INVERTEC® V155-S.
 2. Perform the **Case Cover Removal Procedure**.
 3. Perform the **Input Filter Capacitor Discharge Procedure**
 4. Visually check for burned areas on both sides of the Inverter Board. If no obvious damage is evident, continue to Step 5.
- Note: The following tests may be performed without dis-connecting the Board
5. Check the IGBT's for "shorts" using the volt/ohmmeter in the diode test position, check each IGBT from emitter to collector. See Figure F.6.

Note: Normal value is approximately 0.40 VDC in one polarity and a charging value in the opposite polarity.

The IGBT's of each channel are connected in parallel so it is only necessary to check one Emitter to Collector of each channel.

6. Check each device from gate to emitter. See Figure F.6

Note: Normal value is approximately .5VDC in both polarities.

Note: Actual readings will vary depending on the meter being used. Similar tests on all devices should give similar results.

These devices will usually fail "shorted" resulting in a zero or very low resistance reading from Emitter to Collector. If they "open" physical damage should be evident.

INVERTEC® V155-S



INVERTER BOARD RESISTANCE TEST (CONTINUED)

FIGURE F.7 – INVERTER BOARD TEST POINTS

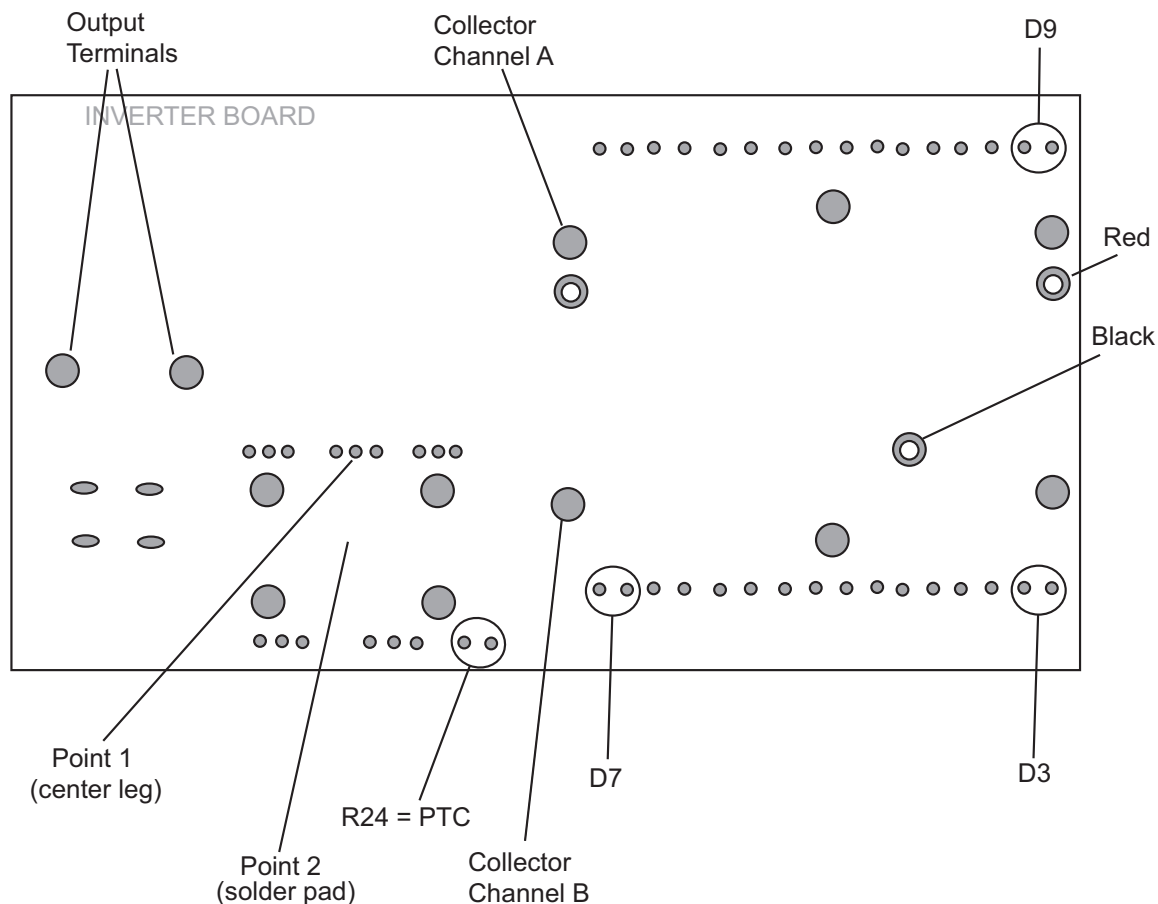

7. Check the diodes D3 and D9 for “shorts” or “opens”. See Figure F.7.
8. Check diode D7, but remember, some resistance (approx. 27-28 ohms) will be read in both polarities. This will occur because D7 is a snubber diode and is connected in parallel to the snubber resistors R8, R9 and R10. See wiring diagram X0519. See Figure F.7.
9. Check the five output diodes for “shorts” or “opens”. Check from the center terminal (Point 1) of each Diode (all center terminals of the diodes are common with the heatsink) to the large copper area “point 2”. See Figure F.7.
10. Check the resistance between the thermal protection terminals R24. It should be about 36-40 ohms. See Figure F.7.
11. Check the resistance between output terminal connections. It should be about 8.5Kohms.

Note: Actual voltage readings will vary depending on the meter being used. Similar tests on all devices should give similar results

INVERTEC® V155-S



Return to Section TOC
Return to Master TOC
Return to Section TOC
Return to Master TOC
Return to Section TOC
Return to Master TOC
Return to Section TOC
Return to Master TOC
Return to Section TOC
Return to Master TOC

INVERTEC® V155-S



INPUT BOARD VOLTAGE TEST

 **WARNING**

Service and repair should be performed by only Lincoln Electric factory trained personnel. Unauthorized repairs performed on this equipment may result in danger to the technician or machine operator and will invalidate your factory warranty. For your safety and to avoid electrical shock, please observe all safety notes and precautions detailed throughout this manual.

If for any reason you do not understand the test procedures or are unable to perform the test/repairs safely, contact the Lincoln Electric Service Department for electrical troubleshooting assistance before you proceed. Call 1-888-935-3877.

TEST DESCRIPTION

This test will help determine if the correct input voltage is being applied to the Input Board and will also determine if the correct voltages are being processed on the Input Board.

MATERIALS NEEDED

Volt/Ohmmeter
Wiring Diagram
Phillips Screwdriver

 **WARNING****ELECTRIC SHOCK can kill.**

- Do not touch electrically live parts such as output terminals or internal wiring.
- Insulate yourself from the work and ground.
- Always wear dry insulating gloves.

FIGURE F.8 – INPUT BOARD TEST POINTS

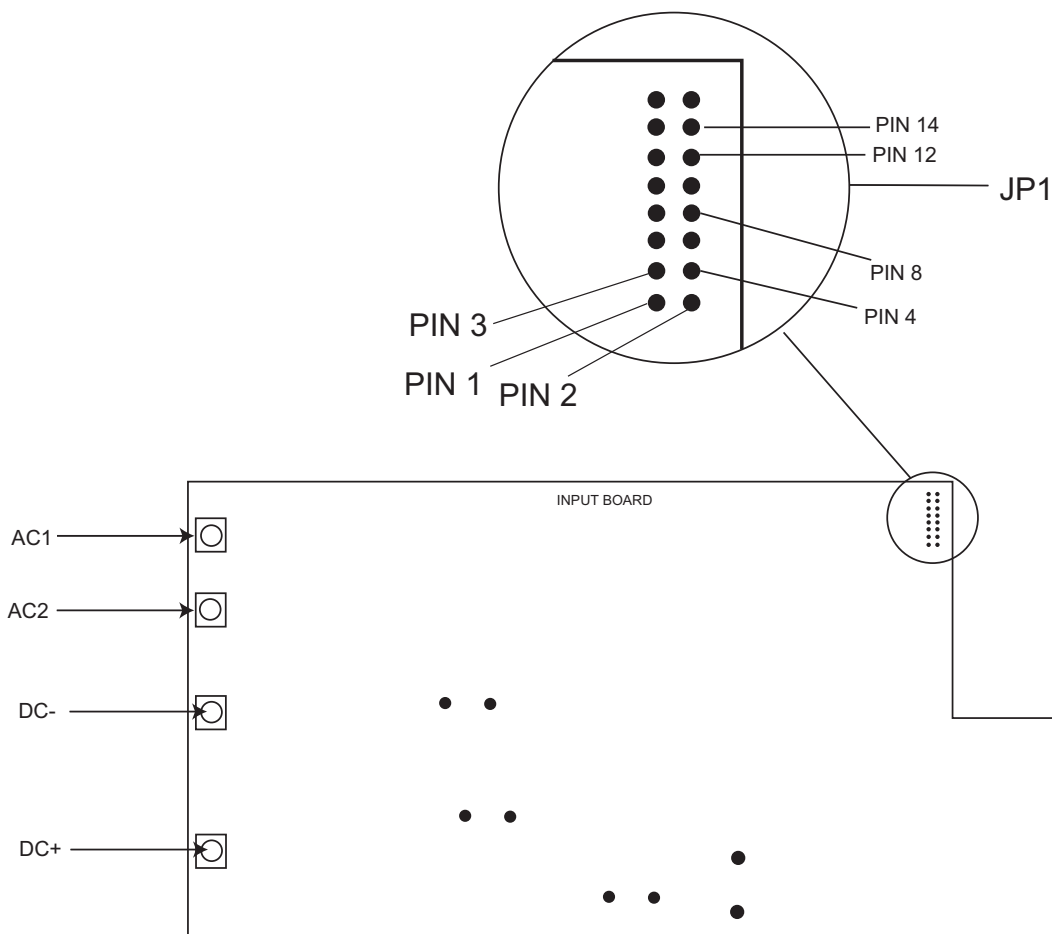

PROCEDURE

1. Disconnect power to the INVERTEC® V155-S.
2. Perform the **Case Cover Removal Procedure (left side only)**.
3. Connect the main 230VAC to the the machine and switch ON the input switch.
4. Using a multimeter, check for 230VAC between AC1 and AC2. See Figure F.8.
5. Check for 320-325VDC between DC+ and DC-
6. Using pin 8,9,15 or 16 of JP1 as a common (-) point:
 - Check pin 2,4 and 14 for +15VDC.
 - Check pin 12 for +5VDC.

Note: Pay attention to wiring diagram very closely. When connecting cables from the Input Board to the Power Switch. You must connect the cables as shown in *Figure F.9*.

PWR 2(white) to 4	PWR 1(blue) to 1
PWR 4(white) to 5	PWR 3(blue) to 2

INVERTEC® V155-S



FIGURE F.9 – MAIN SWITCH PLUG LOCATION

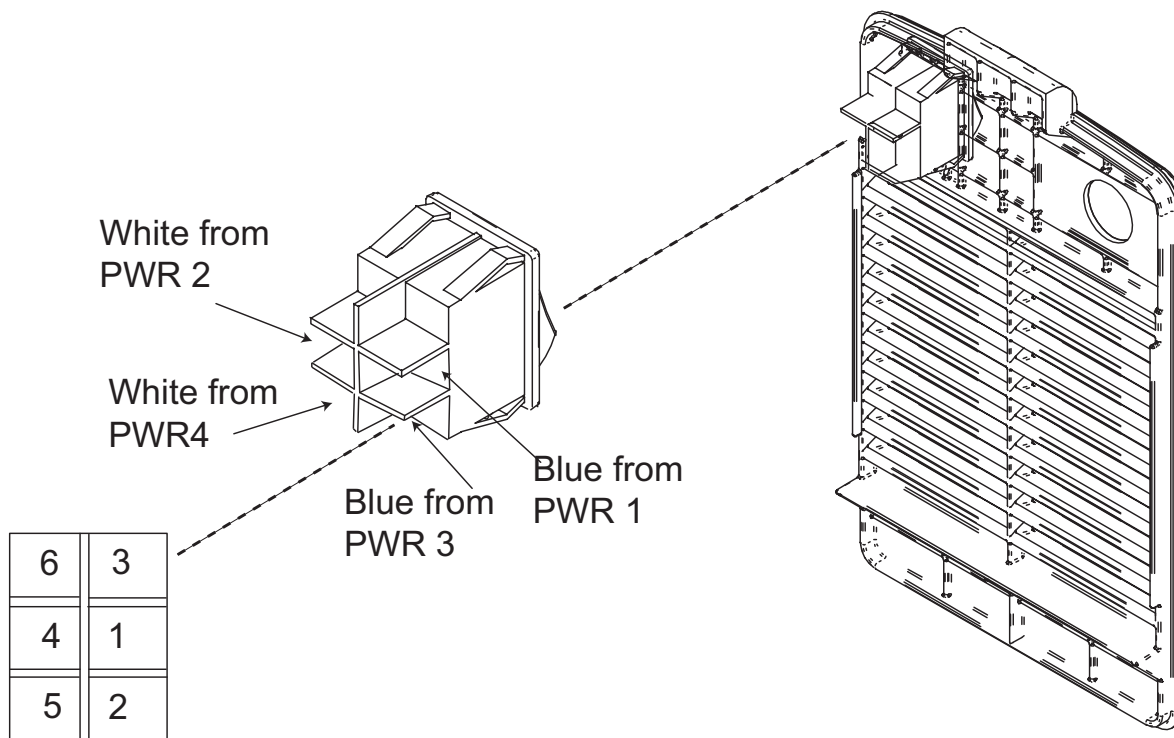

1. Put the blue wire from PWR3 in position 2 of the main switch while the white wire from PWR4 in position 5.
2. Put the blue wire from PWR1 in position 1 of the main switch while the white wire from PWR2 in position 4.

Return to Section TOC
Return to Master TOC
Return to Section TOC
Return to Master TOC
Return to Section TOC
Return to Master TOC
Return to Section TOC
Return to Master TOC
Return to Section TOC
Return to Master TOC

INVERTEC® V155-S



WARNING

Service and repair should be performed by only Lincoln Electric factory trained personnel. Unauthorized repairs performed on this equipment may result in danger to the technician or machine operator and will invalidate your factory warranty. For your safety and to avoid electrical shock, please observe all safety notes and precautions detailed throughout this manual.

If for any reason you do not understand the test procedures or are unable to perform the test/repairs safely, contact the Lincoln Electric Service Department for electrical troubleshooting assistance before you proceed. Call 1-888-935-3877.

TEST DESCRIPTION

This test will help determine if the main inverter board is receiving the correct input voltages and if the correct regulated voltages are being processed and maintained by the main inverter board.

MATERIALS NEEDED

Volt/Ohmmeter
Wiring Diagram X0701 and X0519
Phillips Screwdriver

WARNING



ELECTRIC SHOCK can kill.

- Do not touch electrically live parts such as output terminals or internal wiring.
- Insulate yourself from the work and ground.
- Always wear dry insulating gloves.

INVERTEC® V155-S



INVERTER BOARD VOLTAGE TEST (CONTINUED)

FIGURE F.10 – PLUG JP1 TESTPOINTS

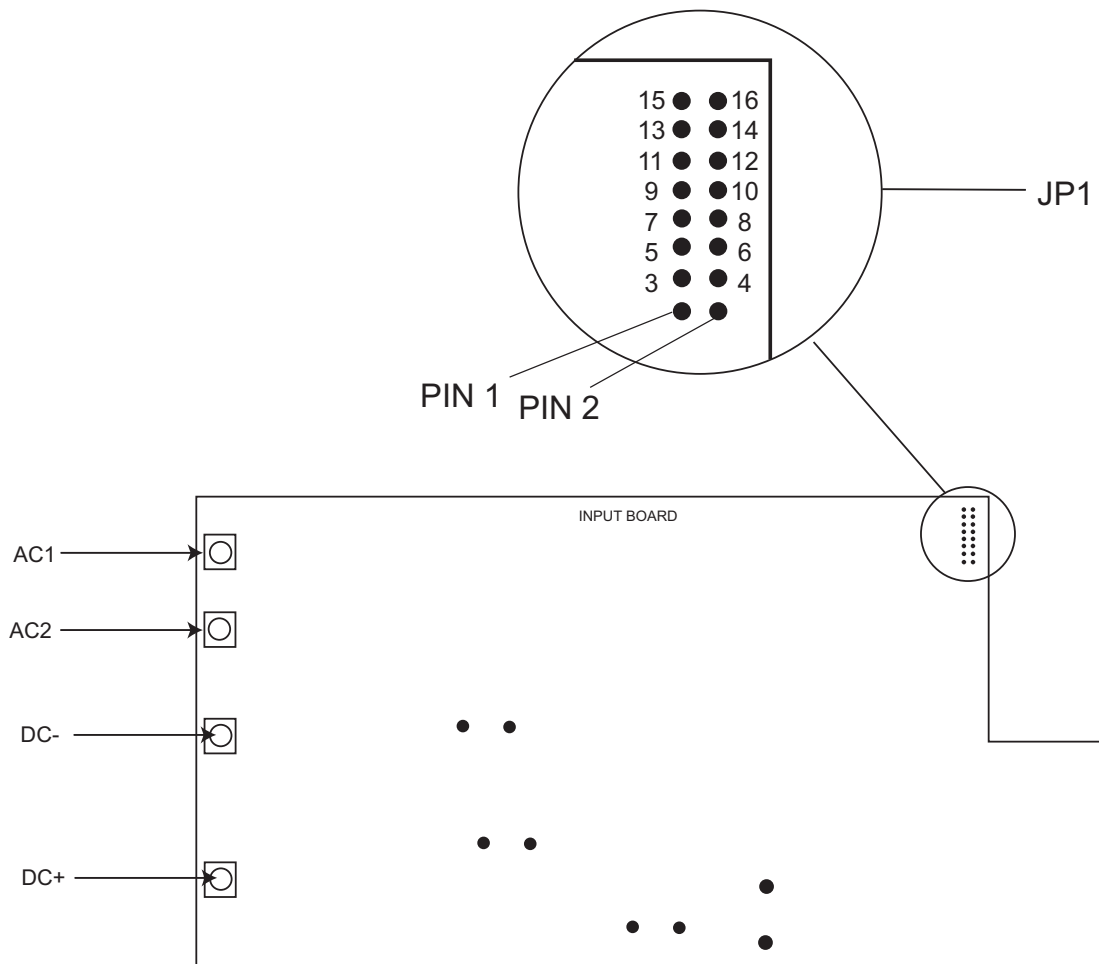

NOTE: DUE TO SAFETY REASONS AND THE PHYSICAL LOCATION OF THE INVERTER, IT IS NOT EASY TO PERFORM THE VOLTAGE TEST AT THE INVERTER BOARD. CHECKS CAN BE DONE AT THE INPUT BOARD CONNECTOR JP1. See Fig. F.10.

PROCEDURE

1. Disconnect power to the INVERTEC® V155-S.
2. Perform the **Case Cover Removal Procedure (left side only)**.
3. Connect the main 230VAC to the machine and switch ON the input switch.
4. Set the machine to STICK mode.
5. Locate the JP1 connector points. See figure F.10.
6. Using pins 8,9,16 or 15 as a common (-) ground:

Check pin 1-> +15VDC means fan is ON. 0VDC means fan is OFF.

Check pin 3-> 0VDC during OCV condition.

Check pin 5-> +11.6VDC means the inverter is ON (the first 5 minutes after activity) while 1.5VDC means the inverter is OFF.

Check pin 6-> value changes from 7.6 to 8.5VDC during reading when the inverter is ON. 50-60 mVDC when the inverter is OFF.

Check pin 7-> +15VDC.

Check pin 11-> +5VDC.

Check pin 12-> +5VDC (supply voltage generated on input board).

Check pin 14-> +15VDC (supply voltage generated on input board).

7. Check to see if the correct microcontroller program is preset: H490000005-004X where X is the revision number.

INVERTEC® V155-S



INPUT BOARD REMOVAL AND REPLACEMENT PROCEDURE

WARNING

Service and repair should be performed by only Lincoln Electric factory trained personnel. Unauthorized repairs performed on this equipment may result in danger to the technician or machine operator and will invalidate your factory warranty. For your safety and to avoid electrical shock, please observe all safety notes and precautions detailed throughout this manual.

If for any reason you do not understand the test procedures or are unable to perform the test/repairs safely, contact the Lincoln Electric Service Department for electrical troubleshooting assistance before you proceed. Call 1-888-935-3877.

TEST DESCRIPTION

This procedure will aid the technician in the removal and replacement of the Input Board.

MATERIALS NEEDED

Phillips Screwdriver
7mm Nutdriver

Return to Section TOC

Return to Master TOC

Return to Section TOC

Return to Master TOC

Return to Section TOC

Return to Master TOC

Return to Section TOC

Return to Master TOC

INVERTEC® V155-S



INPUT BOARD REMOVAL AND REPLACEMENT PROCEDURE

FIGURE F.11 – SCREW AND LEAD LOCATION

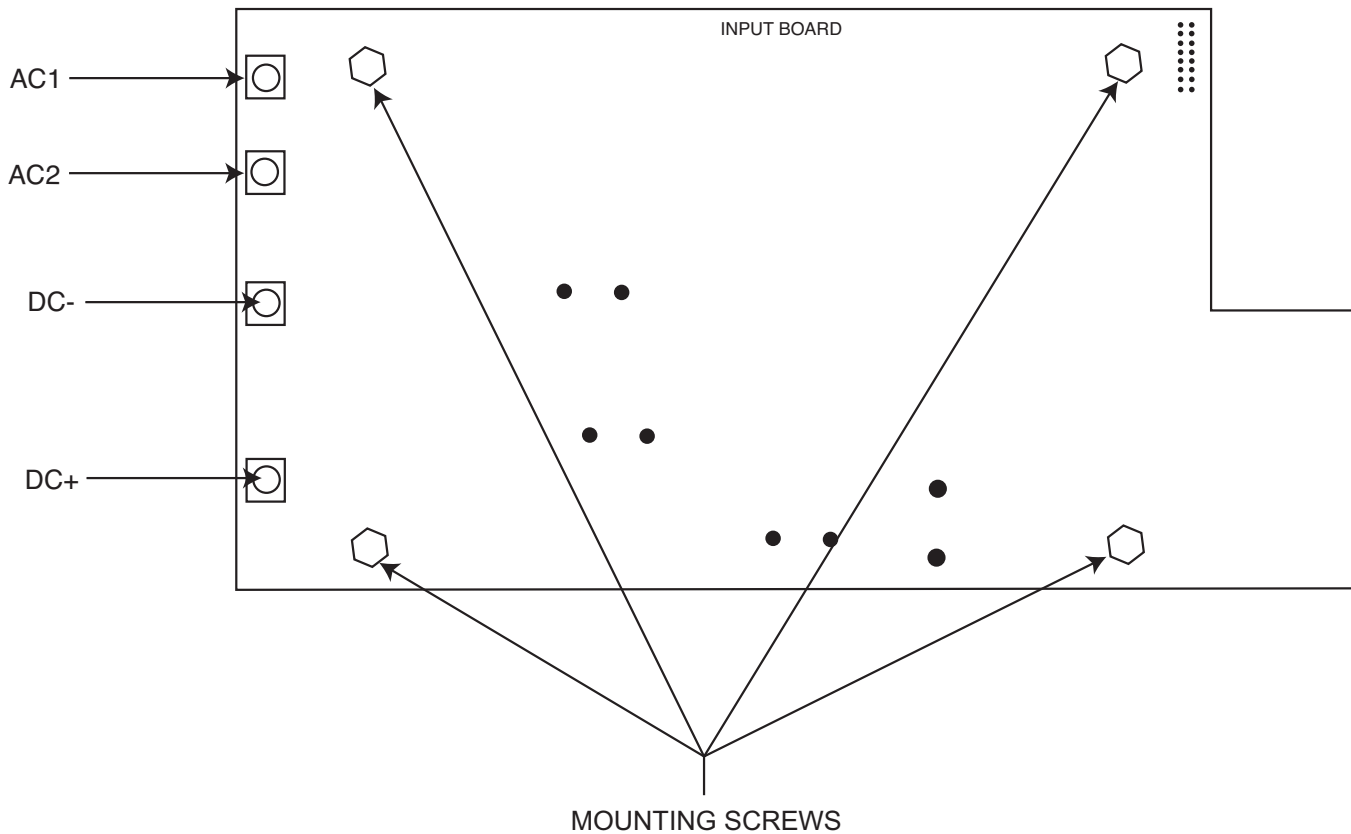
**PROCEDURE**

1. Disconnect power to the INVERTEC® V155-S.
2. Perform the **Case Cover Removal Procedure (Left side only)**.
3. Perform the **Input Filter Capacitor Discharge Procedure**.
4. Label and disconnect the four leads at the Power Switch located on the case back.
5. Using a 7mm nutdriver, remove the four input board mounting screws. This will allow the board to be gently pulled forward to gain access to associated leads and plugs. See Figure F.11.
6. Label and remove all associated leads and plugs. Some leads will require a 7mm nutdriver for removal.
7. Remove and replace the Input board.
8. Connect all leads and plugs previously removed.
9. Replace the four mounting screws previously removed.
10. Replace the case cover.

INVERTEC® V155-S



INVERTER BOARD REMOVAL AND REPLACEMENT PROCEDURE

WARNING

Service and repair should be performed by only Lincoln Electric factory trained personnel. Unauthorized repairs performed on this equipment may result in danger to the technician or machine operator and will invalidate your factory warranty. For your safety and to avoid electrical shock, please observe all safety notes and precautions detailed throughout this manual.

If for any reason you do not understand the test procedures or are unable to perform the test/repairs safely, contact the Lincoln Electric Service Department for electrical troubleshooting assistance before you proceed. Call 1-888-935-3877.

TEST DESCRIPTION

This procedure will aid the technician in the removal and replacement of the Inverter Board.

MATERIALS NEEDED

- Phillips Screwdriver
- 7mm Nutdriver
- 10mm Nutdriver
- Socket extension (6" minimum)

INVERTEC® V155-S



INVERTER BOARD REMOVAL AND REPLACEMENT PROCEDURE (CONTINUED)

FIGURE F.12 – DOOR REMOVAL

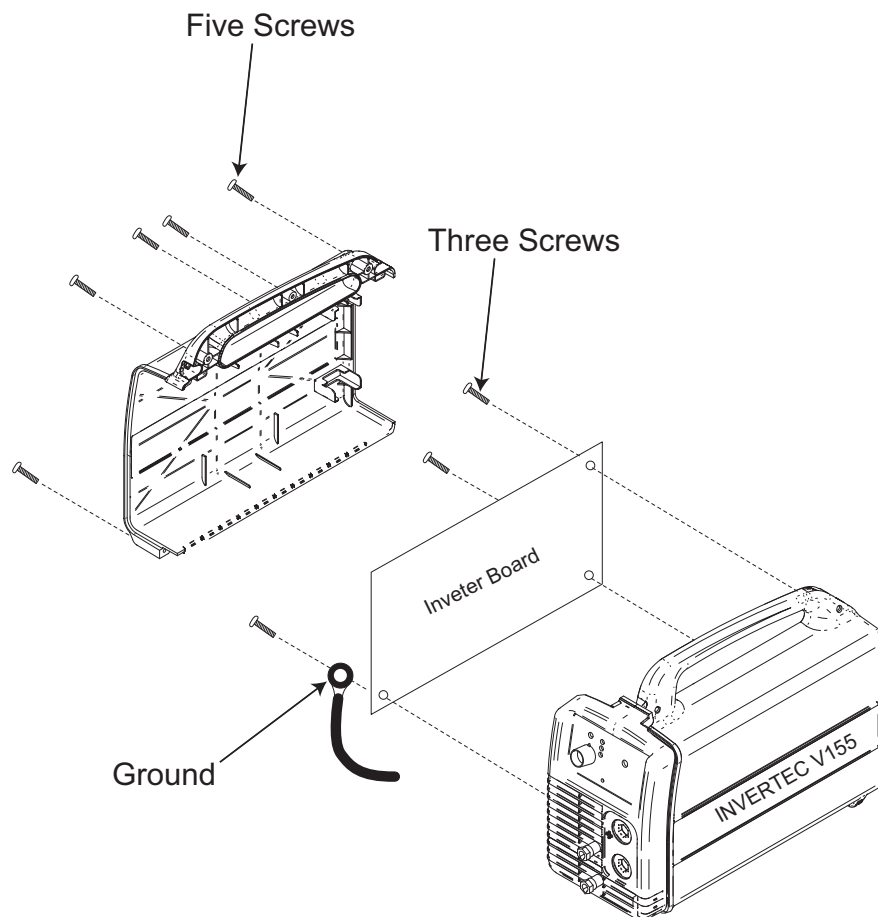

PROCEDURE

1. Disconnect power to the INVERTEC® V155-S.
2. Perform the **Case Cover Removal Procedure**.
3. Perform the **Input Filter Capacitor Discharge Procedure**.
4. Perform the **Input Board Removal Procedure**.
5. Using phillips screwdriver, remove the three screws mounting the inverter board to the right side case cover. These screws can only be seen/accessed through the left side of the machine with the left side case cover removed. See Figure F.12.
6. Note location of ground lead upon removal of lower right phillips screw.

Note: Pay attention to wiring diagram very closely. When connecting cables from the Input Board to the Power Switch. You must connect the cables as shown in *Figure F.9*.

PWR 2(white) to 4	PWR 1(blue) to 1
PWR 4(white) to 5	PWR 3(blue) to 2

INVERTEC® V155-S



INVERTER BOARD REMOVAL AND REPLACEMENT PROCEDURE (CONTINUED)

FIGURE F.13 – INVERTER BOARD REMOVAL

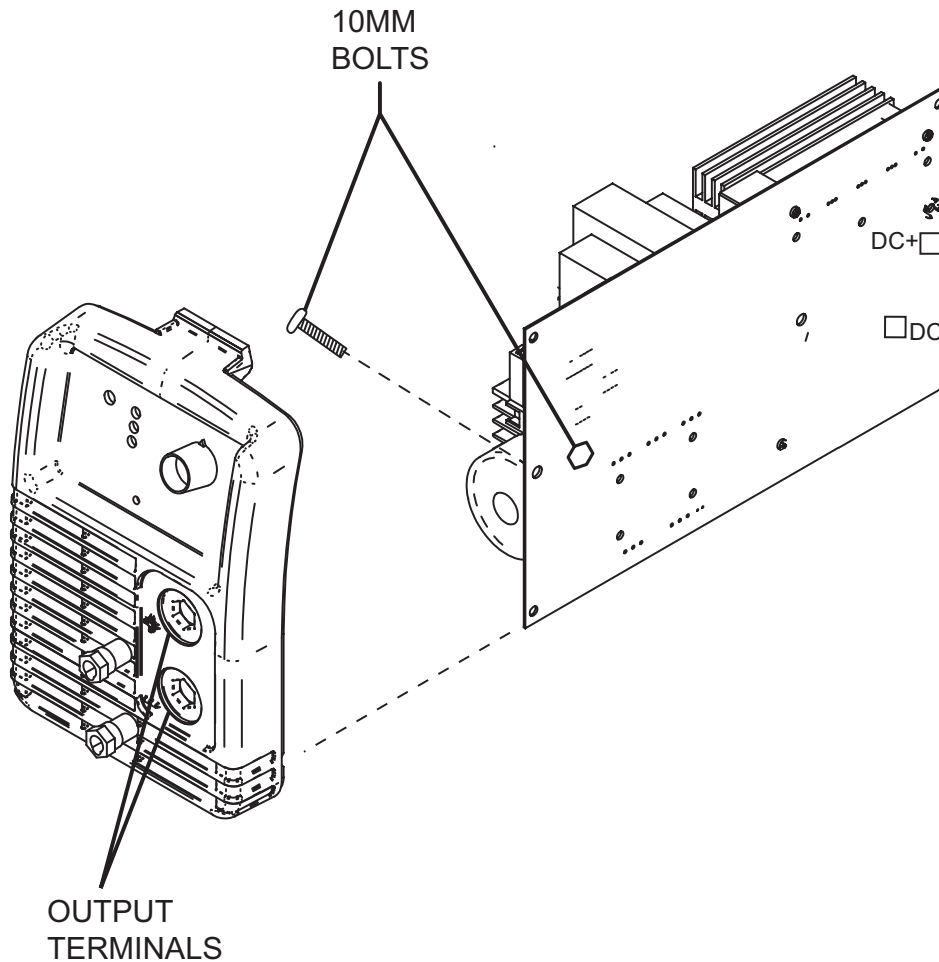

- Using a 10mm nutdriver with extension, remove the two bolts mounting the inverter board to the positive (+) and negative (-) leads that connect to the output terminals on the front of the machine. See Figure F.13

Note: One 10mm mounting bolt can be accessed from the soldered side of the inverter board. The other bolt must be accessed from the left side of the machine using the socket extension. Note washer placement for reassembly,

- Label and disconnect any associated plugs and leads.

- Remove the inverter board.
- Connect JP 1 connector and make sure that the upper front corner of the board is in the locator slot of the front panel.
- Be sure that the white lead is re-connected to the Positive Input terminal.
- Re-connect the red and black leads to the DC+ and DC- points on the Inverter Board.
- Re-install the Inverter to the case, making sure the ground lead is re-connected to the lower front corner.

INVERTEC® V155-S



Return to Section TOC
Return to Master TOC
Return to Section TOC
Return to Master TOC
Return to Section TOC
Return to Master TOC
Return to Section TOC
Return to Master TOC
Return to Section TOC
Return to Master TOC

INVERTEC® V155-S



CONTROL BOARD REMOVAL AND REPLACEMENT PROCEDURE**⚠ WARNING**

Service and repair should be performed by only Lincoln Electric factory trained personnel. Unauthorized repairs performed on this equipment may result in danger to the technician or machine operator and will invalidate your factory warranty. For your safety and to avoid electrical shock, please observe all safety notes and precautions detailed throughout this manual.

If for any reason you do not understand the test procedures or are unable to perform the test/repairs safely, contact the Lincoln Electric Service Department for electrical troubleshooting assistance before you proceed. Call 1-888-935-3877.

TEST DESCRIPTION

This procedure will aid the technician in the removal and replacement of the Control Board.

MATERIALS NEEDED

- Phillips Screwdriver
- Metric Nut Drivers
- Socket extension (6" minimum)

CONTROL BOARD REMOVAL AND REPLACEMENT PROCEDURE (*CONTINUED*)

FIGURE F.14 CONTROL BOARD REMOVAL

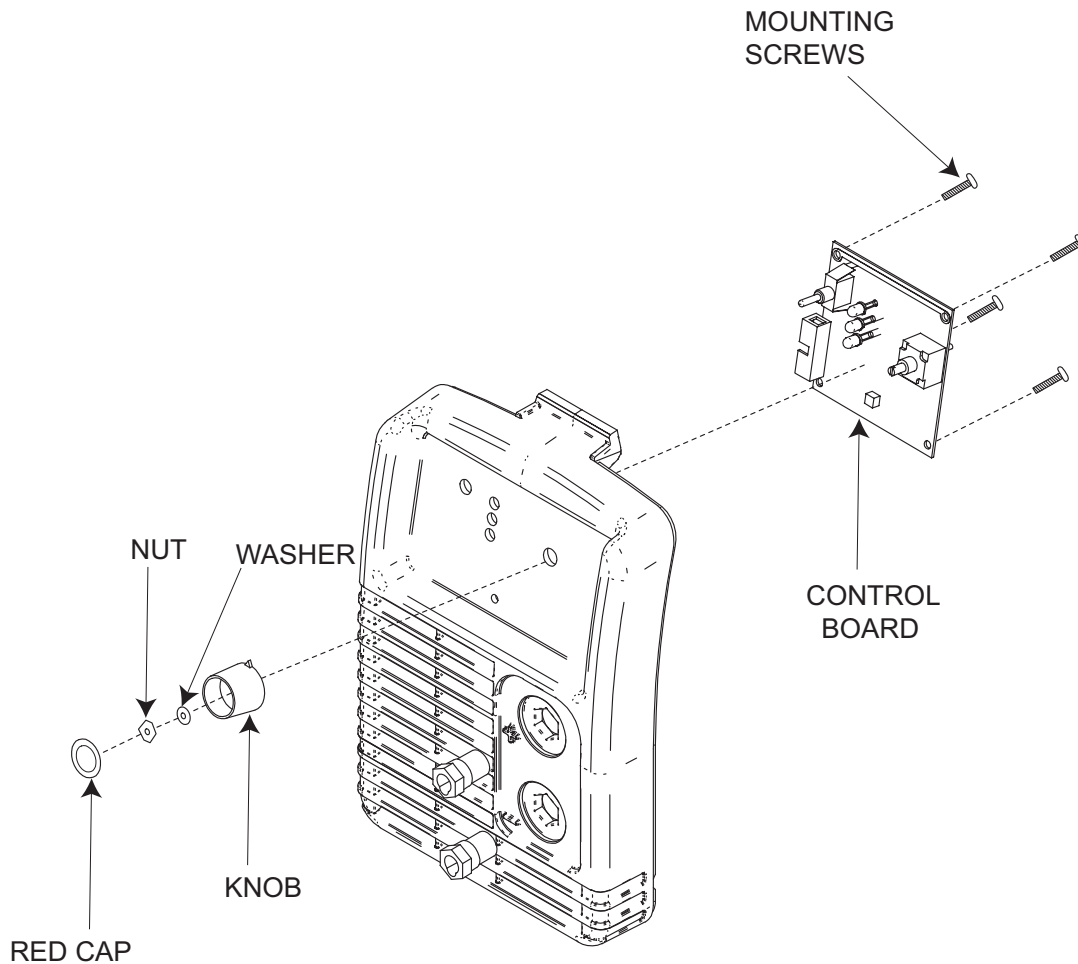
**PROCEDURE**

1. Disconnect power to the INVERTEC® V155-S.
2. Perform the **Case Cover Removal Procedure (left side only)**.
3. Perform the **Input Filter Capacitor Discharge Procedure**.
4. Perform the **Input Board Removal Procedure**.
5. Perform the **Inverter Board Removal Procedure**.
6. Using a thin knife blade, remove the red plastic on the end of the output knob, See Figure F.14.
7. Using a 6mm nutdriver, remove the output knob mounting nut and washer located behind the red plastic cap previously removed. See Figure F.14.
8. Disconnect the JP1 connector.
9. Using a phillips screwdriver, remove the four mounting screws located on the corners of the solder side of the control board.
10. Disconnect the JP2 connector.
11. Remove and replace the control board.

Note: When installing the new control board, be sure to turn the output potentiometer shaft completely counter clockwise prior to fastening knob into place. This will assure that the output setting is at it's lowest setting. This will allow proper installation of the output knob with the red arrow pointing to the lowest setting possible. If this is not done properly, the machine output will not match the set current.

INVERTEC® V155-S



RETEST AFTER REPAIR

Should a machine under test be rejected for any reason requiring the removal of any mechanical part that could affect the machine's electrical characteristics, or if any electrical components are repaired or replaced, the machine must be retested.

INPUT- SINGLE PHASE ONLY			
Input Volts 50/60-HertzMax.	Input Current at Rated Output	Input Power at Rated Output	
		100%	30%
120VAC +/- 10%	34 A	2kw	3kw
230VAC +/- 10%	33 A	2kw	3kw
RATED OUTPUT			
Duty Cycle	Output Amps	Output Volts	Input Circuit
100%	75A (stick) 105A (TIG)	23.0 Vdc 14.2 Vdc	120 Vac
	100A (stick) 100A (TIG)	24.0 Vdc 14.0 Vdc	230 Vac
30%	100A (stick) 130A (TIG)	24.0 Vdc 15.2 Vdc	120 Vac
	145A (stick) 155A (TIG)	25.8 Vdc 16.2 Vdc	230 Vac
OUTPUT			
Output Current Range	Maximum Open Circuit Voltage		Type of Output
5-155 Amps	75 Volts Max.		DC

RECOMMENDED METERS FOR MACHINE OUTPUT TESTS

VOLTMETER: AC and DC True RMS Meter - Fluke 8922A or equivalent

AMMETER: Columbia Type AX AC or DC Tong Ammeter

IMPORTANT: IF OTHER TYPE METERS ARE USED RESULTS MAY NOT BE ACCURATE.

INVERTEC® V155-S



Return to Section TOC
Return to Master TOC
Return to Section TOC
Return to Master TOC
Return to Section TOC
Return to Master TOC
Return to Section TOC
Return to Master TOC
Return to Section TOC
Return to Master TOC

INVERTEC® V155-S



Return to Master TOC

Return to Master TOC

Return to Master TOC

Return to Master TOC

Electrical DiagramsG-1

 Wiring Diagram (W07X071)G-2

 Schematic - Complete Machine (X0931)G-3

 Schematic - Input Board (X0791)G-4

 PC Board Assembly - Input BoardG-5

 Schematic - Inverter Board (X0519 - Sheet 1)G-6

 Schematic - Inverter Board (X0519 - Sheet 2)G-7

 PC Board Assembly - Inverter Board - Sheet 1G-8

 PC Board Assembly - Inverter Board - Sheet 2G-9

 Schematic - Control Board (W05X0708)G-10

 PC Board Assembly - Control Board - Sheet 1G-11

 PC Board Assembly - Control Board - Sheet 2G-12

*** NOTE:** Many PC Board Assemblies are now totally encapsulated, surface mounted and or multi-layered and are therefore considered to be unserviceable. Assembly drawings of these boards are no longer provided.

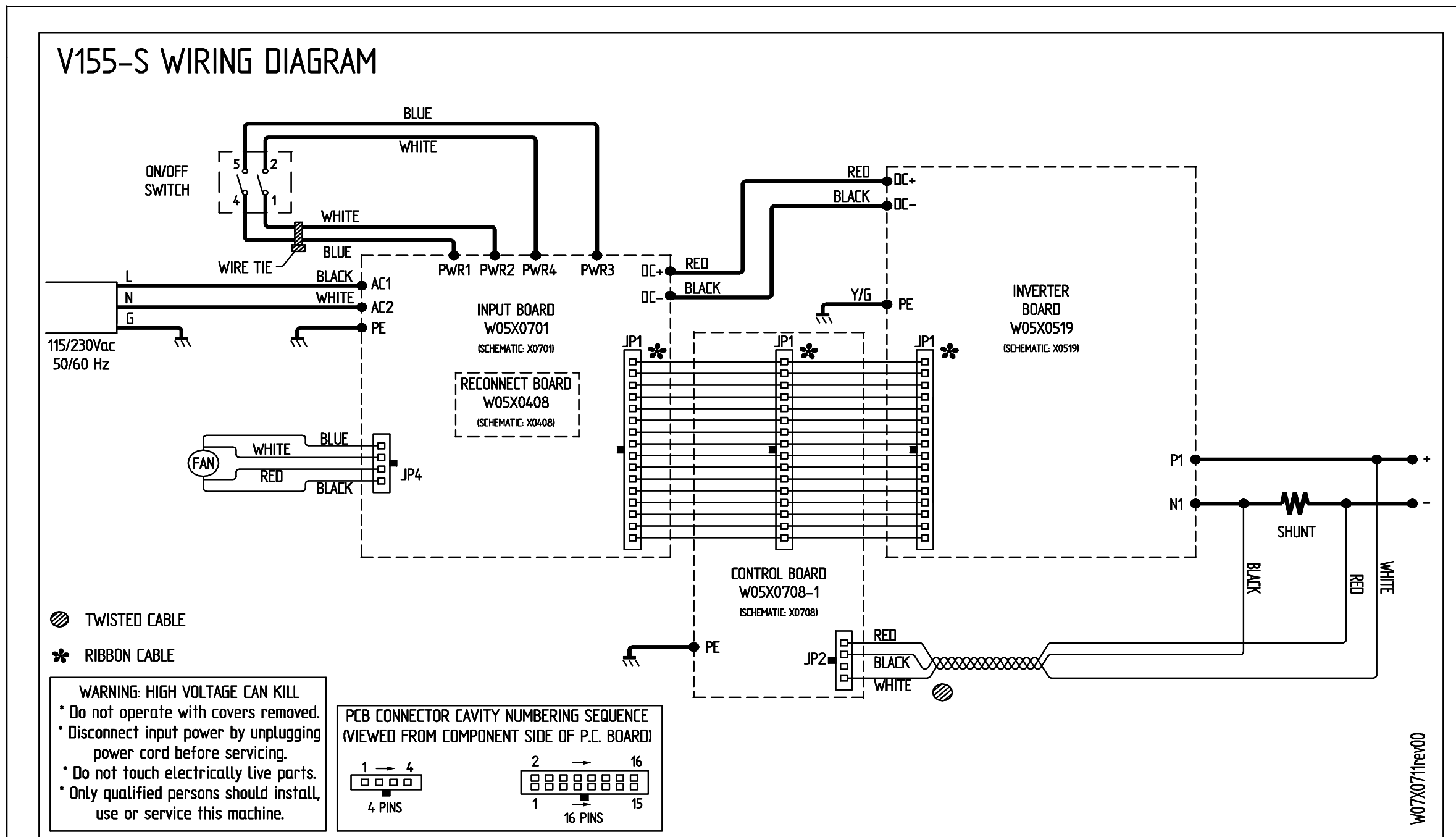

MATERIALE: FILM PVC CALANDRATO MORBIDO SENZA CADMIO MONOMERICO
 ASPETTO BRILLANTE AUTOADESIVO DI COLORE BIANCO
 SCRITTE E DISEGNI: COLORE NERO

SENZA SPECIFICA AUTORIZZAZIONE DI LINCOLN ELECTRIC ITALIA È VIETATA LA DIVULGAZIONE DEL PRESENTE DOCUMENTO.

This sheet contains proprietary information owned by LINCOLN ELECTRIC ITALIA and is not to be reproduced, disclosed, or used without the express permission of LINCOLN ELECTRIC ITALIA.

LINCOLN ELECTRIC ITALIA S.r.l. SERRA RICCO' (GE), ITALIA		DESCRIZIONE	
		ADESIVO	
		WIRING DIAGRAM V155-S	
DOVE NON SPECIFICATO LE QUOTE DISEGNO SONO ESPRESSE IN MILLIMETRI		TOLLERANZA: ±0.5mm	FOGLIO 1 DI 1
SCALA 1:1	DATA 27/06/2006	NUMERO DI DISEGNO	
DISEGN. D. Scaldaferrì	APPR.	W07X0711	
		REV.	00

NOTE: This diagram is for reference only. It may not be accurate for all machines covered by this manual. The wiring diagram specific to your code is pasted inside one of the enclosure panels of your machine.

SCHEMATIC - COMPLETE MACHINE - CODES 11326 & 11327

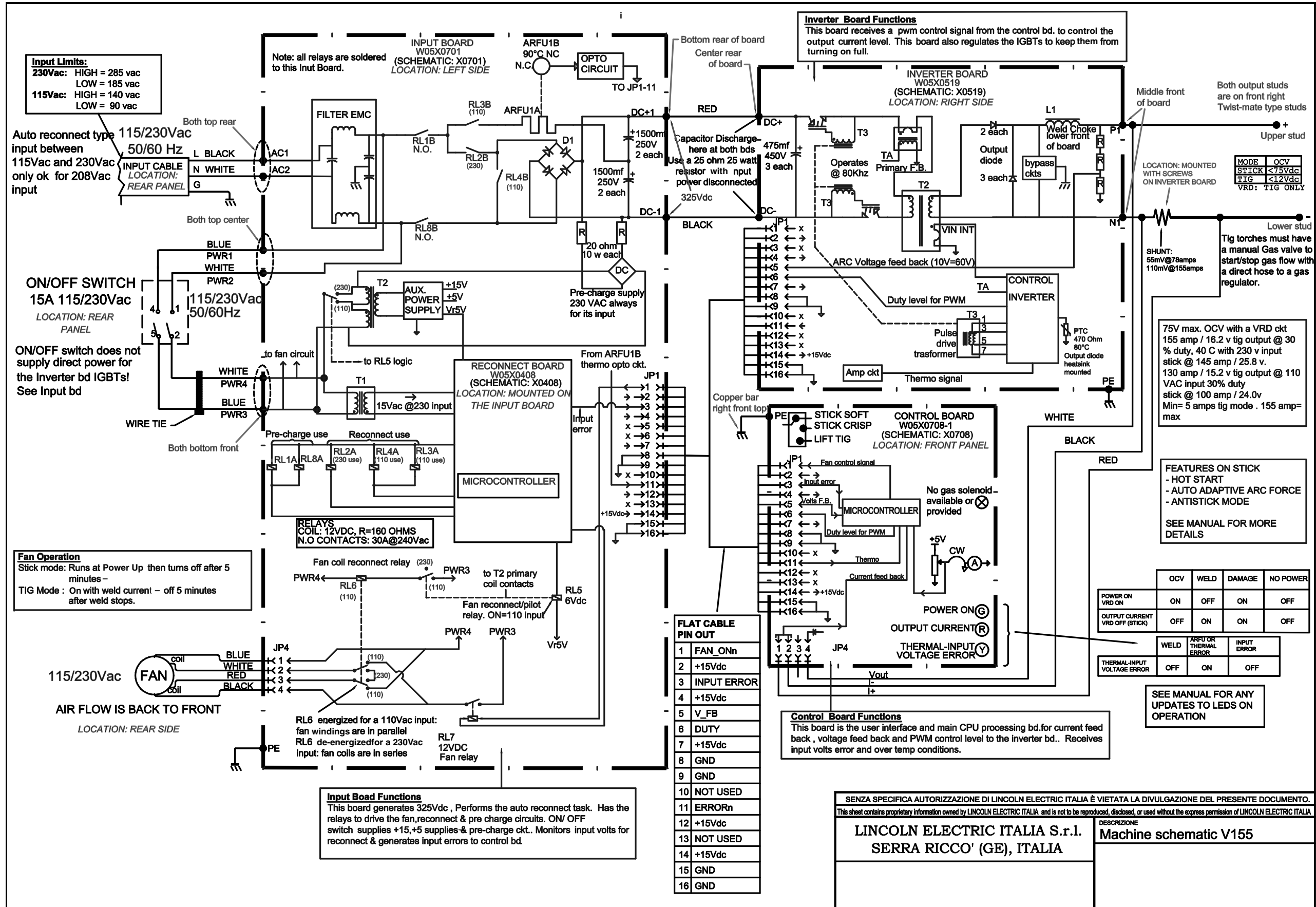

NOTE: This diagram is for reference only. It may not be accurate for all machines covered by this manual.

SCHEMATIC - INPUT PC BOARD

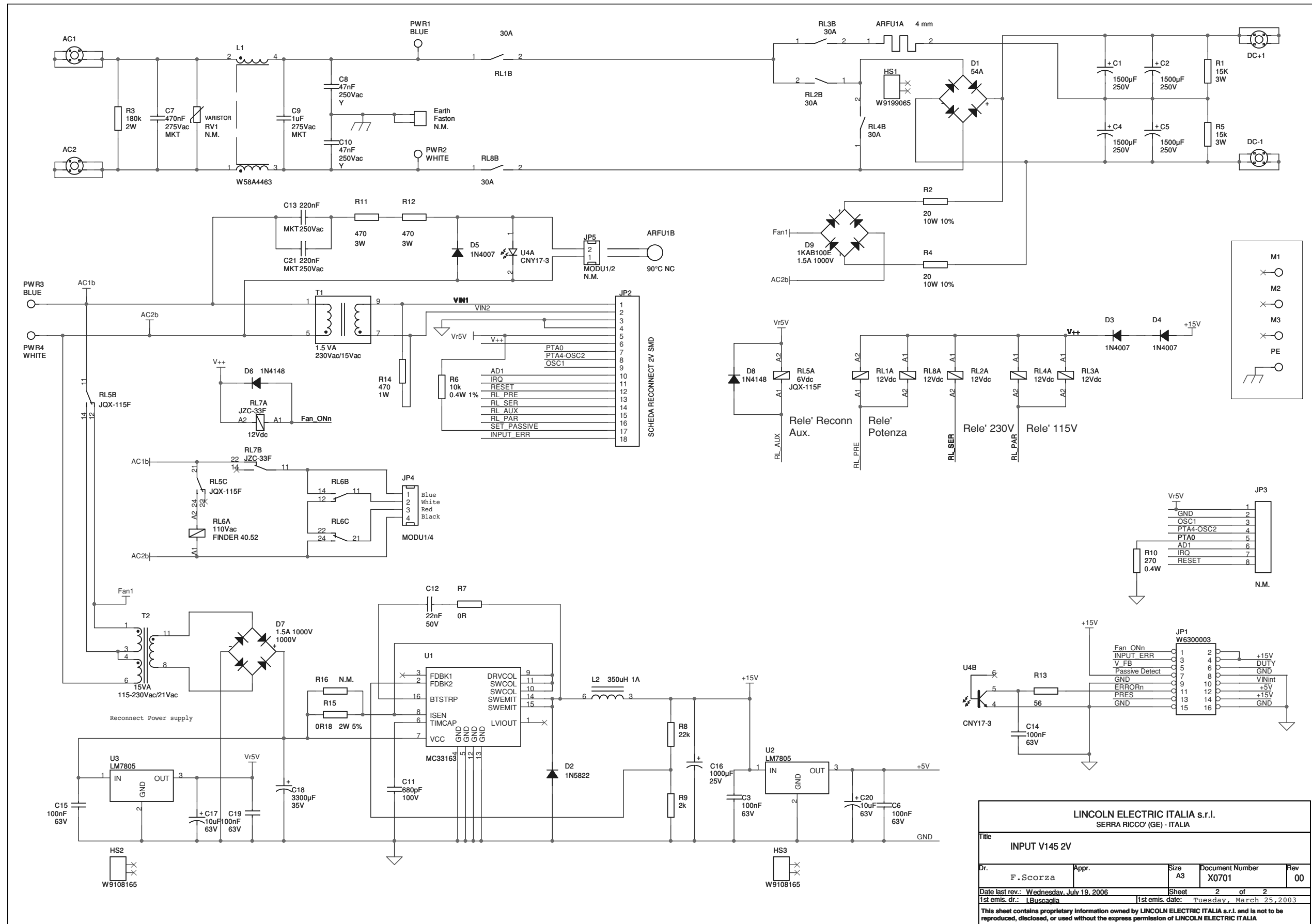

LINCOLN ELECTRIC ITALIA s.r.l. SERRA RICCO' (GE) - ITALIA				
INPUT V145 2V				
Dr.	F. Scorza	Appr.		
Date last rev.:	Wednesday, July 19, 2006	Sheet	2 of 2	Rev
1st emis. dr.:	lBusaglia	1st emis. date:	Tuesday, March 25, 2003	00
<small>This sheet contains proprietary information owned by LINCOLN ELECTRIC ITALIA s.r.l. and is not to be reproduced, disclosed, or used without the express permission of LINCOLN ELECTRIC ITALIA</small>				

NOTE: This diagram is for reference only. It may not be accurate for all machines covered by this manual.



Return to Section TOC

Return to Master TOC

Return to Section TOC

Return to Master TOC

Return to Section TOC

Return to Master TOC

Return to Section TOC

Return to Master TOC

PC BOARD ASSEMBLY - INPUT BOARD

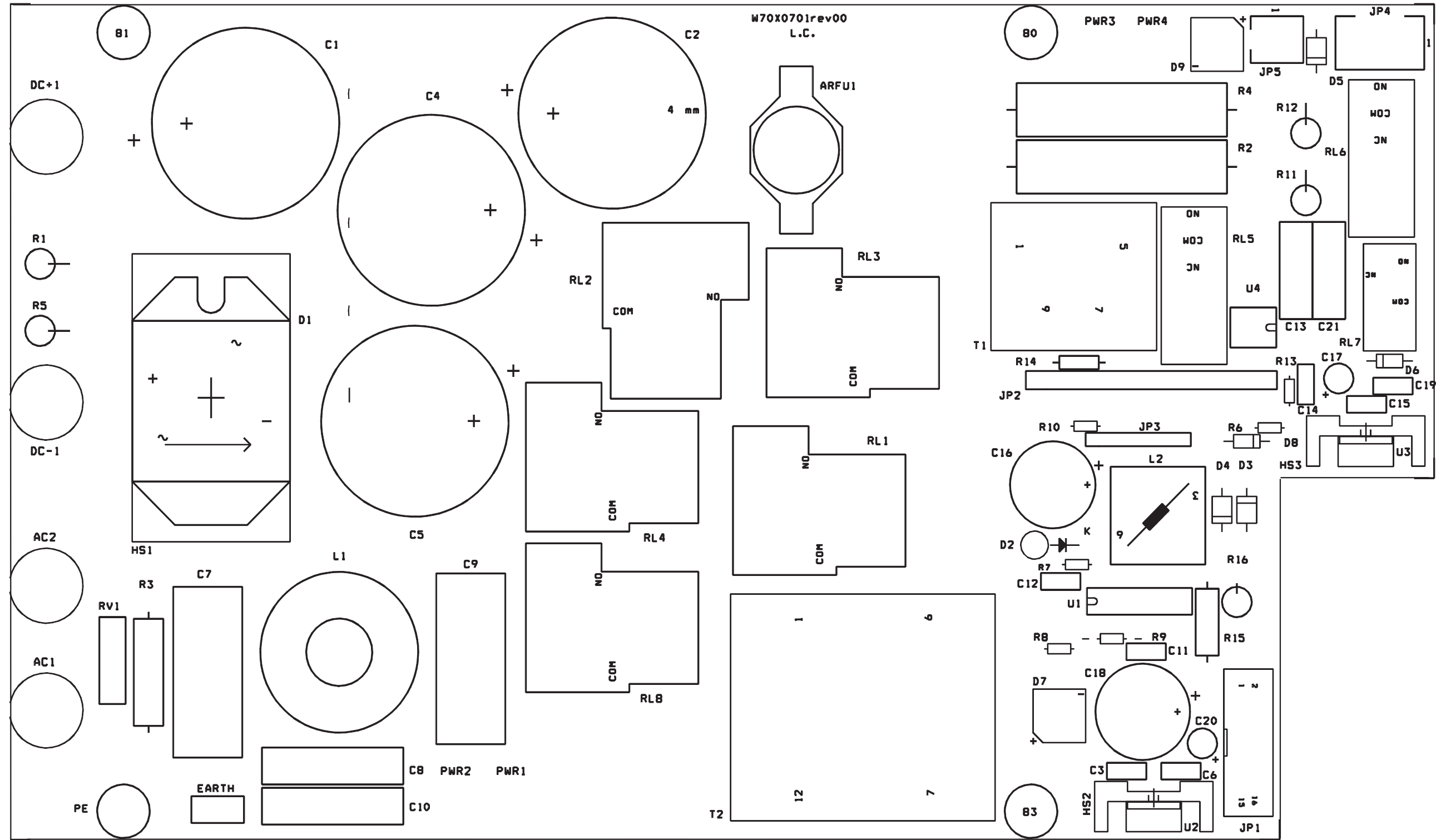

LINCOLN ELECTRIC ITALIA s.r.l. SERRA RICCO' (GE) - ITALIA			
Title CIRCUITO STAMPATO Serigrafia			
Dr. Pertica	Appr.	Document Number W70X0701	Rev. 00
Date last rev.: 21/04/06	Sheet	1 di 6	
1st emis. dr.: Pertica	1st emis. date:	21/04/06	
This sheet contains proprietary information owned by LINCOLN ELECTRIC ITALIA s.r.l. and is not to be reproduced, disclosed or used without the express permission of LINCOLN ELECTRIC ITALIA s.r.l.			

NOTE: Lincoln Electric assumes no responsibility for liabilities resulting from board level troubleshooting. PC Board repairs will invalidate your factory warranty. **Individual Printed Circuit Board Components are not available from Lincoln Electric.** This information is provided for reference only. Lincoln Electric discourages board level troubleshooting and repair since it may compromise the quality of the design and may result in danger to the Machine Operator or Technician. Improper PC board repairs could result in damage to the machine.



Return to Section TOC
Return to Master TOC

Return to Section TOC
Return to Master TOC

Return to Section TOC
Return to Master TOC

Return to Section TOC
Return to Master TOC

SCHEMATIC - INVERTER PC BOARD - SHEET #2

Return to Section TOC
Return to Master TOC

Return to Section TOC
Return to Master TOC

Return to Section TOC
Return to Master TOC

Return to Section TOC
Return to Master TOC

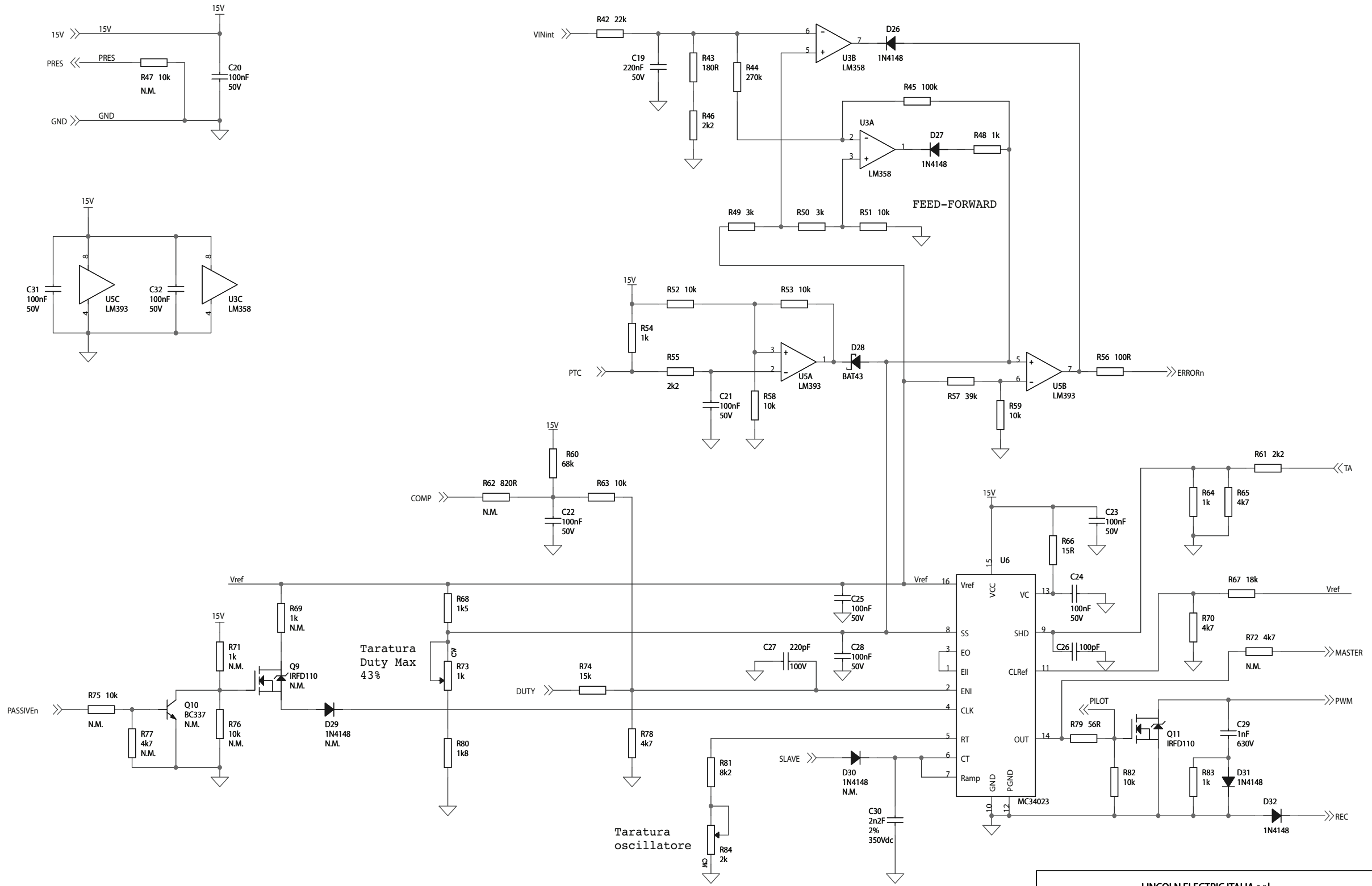

LINCOLN ELECTRIC ITALIA s.r.l.				
SERRA RICCO' (GE) - ITALIA				
Title				
INVERTER BOARD V145				
Dr.	Appr.	Size	Document Number	Rev
V. Natarelli		A3	X0519	02
Date last rev.: Friday, February 17, 2006		Sheet 3 of 3		
1st emis. dr.: J. Daniel		1st emis. date: Friday, January 31, 2003		
<small>This sheet contains proprietary information owned by LINCOLN ELECTRIC ITALIA s.r.l. and is not to be reproduced, disclosed, or used without the express permission of LINCOLN ELECTRIC ITALIA</small>				

NOTE: This diagram is for reference only. It may not be accurate for all machines covered by this manual.

SCHEMATIC - CONTROL PC BOARD

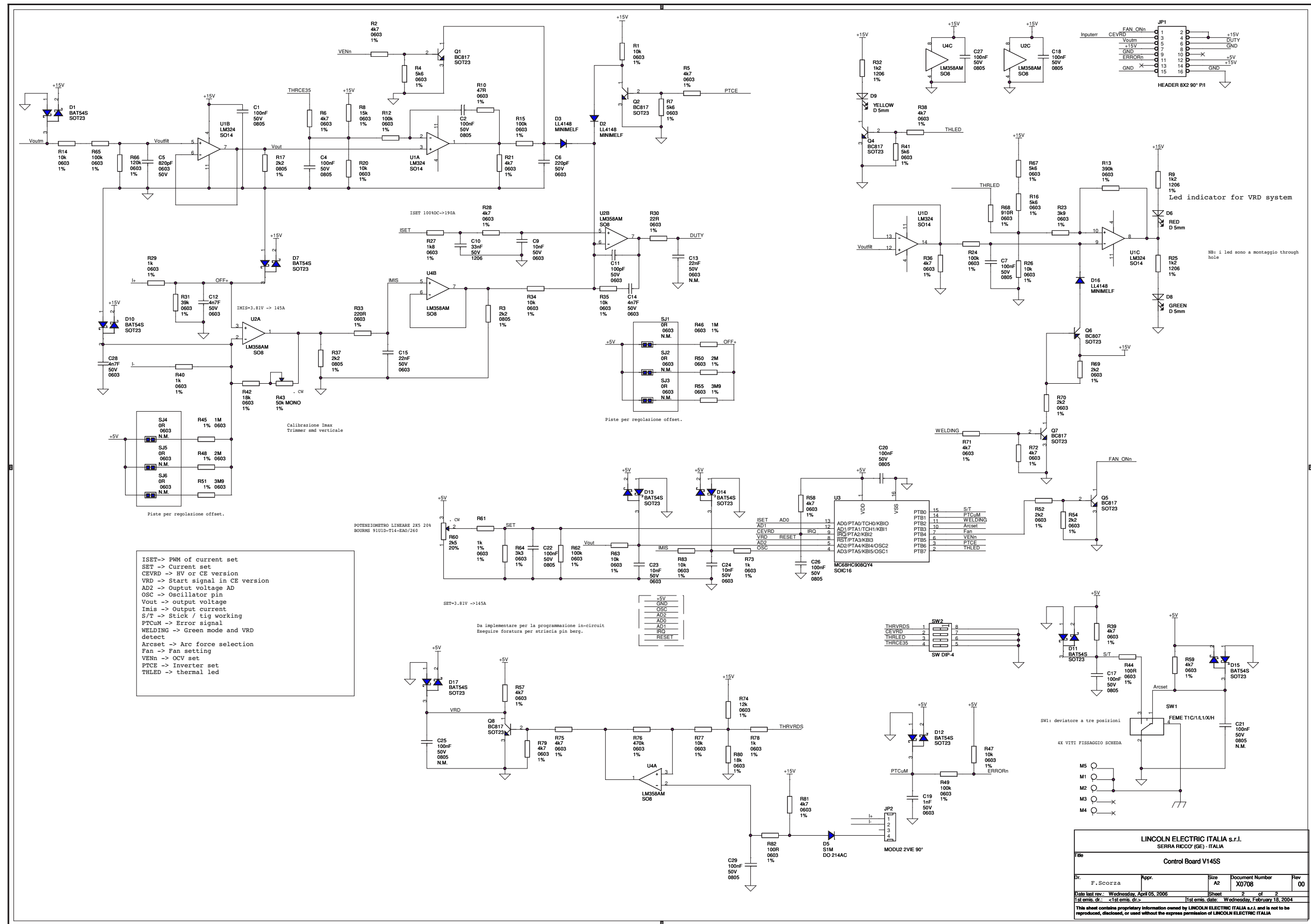

NOTE: This diagram is for reference only. It may not be accurate for all machines covered by this manual.



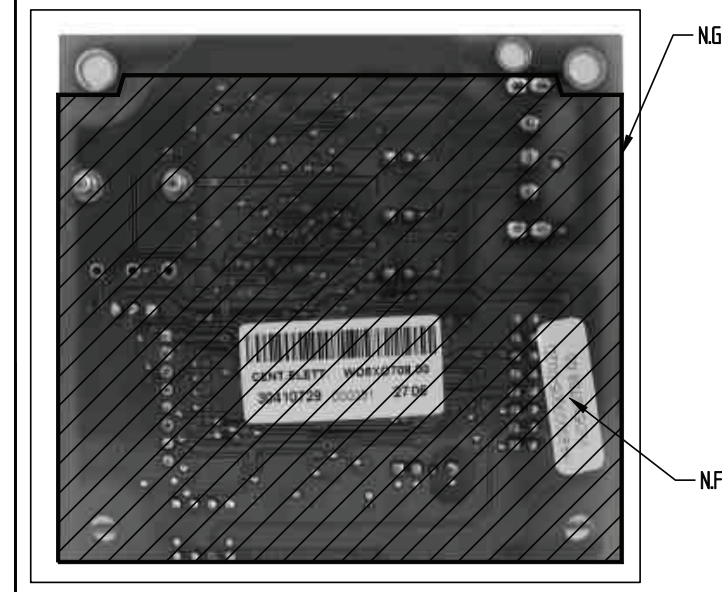
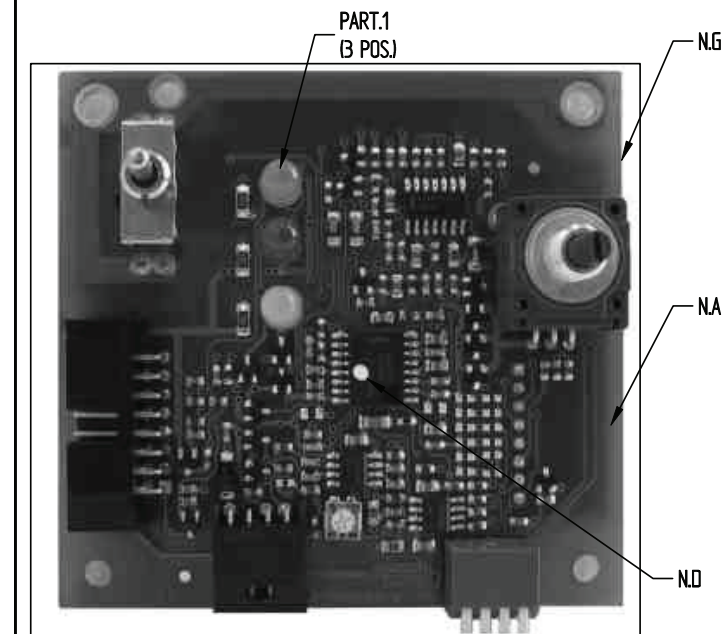
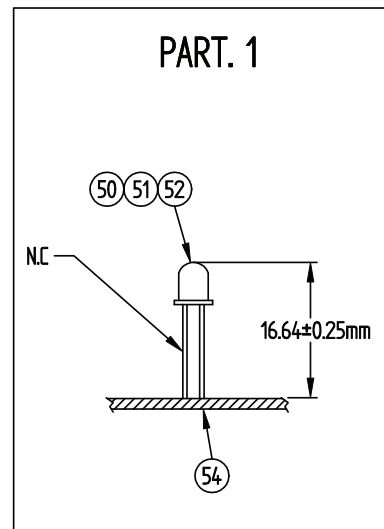
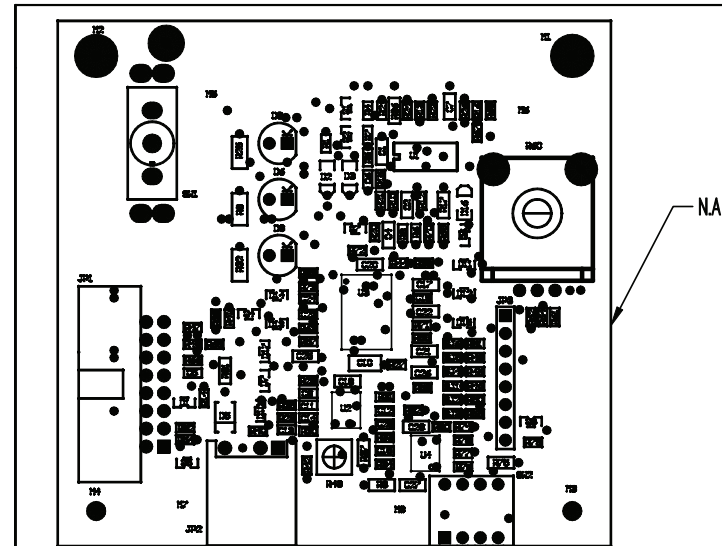

* See Page 2 for more detailed component information

Rif.	Codice	Descrizione	Topografia	QUANTITA'		
				W05X0708	W05X0708-1	W05X0708-2
1	H10DE22ROC	RES SM 22R 0.1W 1% 0603	R30	1	1	1
2	H10DE47ROC	RES SM 47R 0.1W 1% 0603	R10	1	1	1
3	H10DE100OC	RES SM 100R 0.1W 1% 0603	R44 R82	2	2	2
4	H10DE220OC	RES SM 220R 0.1W 1% 0603	R33	1	1	1
5	H10DE910OC	RES SM 910R 0.1W 1% 0603	R68	1	1	1
6	H10DE1001C	RES SM 1K 0.1W 1% 0603	R29 R40 R61 R73 R78	5	5	5
7	H10DE1801C	RES SM 1K8 0.1W 1% 0603	R27	1	1	1
8	H10DE2201C	RES SM 2K2 0.1W 1% 0603	R52 R54 R69 R70	4	4	4
9	H10DE3301C	RES SM 3K3 0.1W 1% 0603	R64	1	1	1
10	H10DE3901C	RES SM 3K9 0.1W 1% 0603	R23	1	1	1
11	H10DE4701C	RES SM 4K7 0.1W 1% 0603	R2 R5 R6 R21 R28 R36 R38 R39 R57 R58 R59 R71 R72 R75 R79 R81	16	16	16
12	H10DE5601C	RES SM 5K6 0.1W 1% 0603	R4 R7 R16 R41 R67	5	5	5
13	H10DE1002C	RES SM 10K 0.1W 1% 0603	R1 R14 R20 R26 R34 R35 R47 R63 R77 R83	10	10	10
14	H10DE1202C	RES SM 12K 0.1W 1% 0603	R74	1	1	1
15	H10DE1502C	RES SM 15K 0.1W 1% 0603	R8	1	1	1
16	H10DE1802C	RES SM 18K 0.1W 1% 0603	R42 R80	2	2	2
17	H10DE3902C	RES SM 39K 0.1W 1% 0603	R31	1	1	1
18	H10DE1003C	RES SM 100K 0.1W 1% 0603	R12 R15 R24 R49 R62 R65	6	6	6
19	H10DE1203C	RES SM 120K 0.1W 1% 0603	R66	1	1	1
20	H10DE3903C	RES SM 390K 0.1W 1% 0603	R13	1	1	1
21	H10DE4703C	RES SM 470K 0.1W 1% 0603	R76	1	1	1
22	H10DE1004C	RES SM 1M 0.1W 1% 0603	R45 R46	2	2	2
23	H10DE2004C	RES SM 2M 0.1W 1% 0603	R48 R50	2	2	2
24	H10DE3904C	RES SM 3M9 0.1W 1% 0603	R51 R55	2	2	2
25	H10FF2201C	RES SM 2K2 0.125W 1% 0805	R3 R17 R37	3	3	3
26	H10J61201C	RES SM 1K2 0.125W 1% 1206	R9 R25 R32	3	3	3
27	H2ZV01503J	TRIMMER 50K 20% 1 GIRO CERMET	R43	1	1	1
28	H3205082H	CCEER X7R 820pF 50V 10% 0603	C5	1	1	1
29	H32050102H	CCEER X7R 1nF 50V 10% 0603	C19	1	1	1
30	H32050472H	CCEER X7R 4n7F 50V 10% 0603	C12 C14 C28	3	3	3
31	H32050103H	CCEER X7R 10nF 50V 10% 0603	C9 C23 C24	3	3	3
32	H32050223H	CCEER X7R 22nF 50V 10% 0603	C15	1	1	1
33	H32F50104H	CCEER X7R 100nF 50V 10% 0805	C1 C2 C4 C7 C17 C18 C20 C22 C26 C27 C29	11	11	11
34	H32J50333H	CCEER X7R 33nF 50V 10% 1206	C10	1	1	1
35	H33050101G	CCEER COG/NPO 100pF 50V 5% 0603	C11	1	1	1
36	H33050221G	CCEER COG/NPO 220pF 50V 5% 0603	C6	1	1	1
37	H400000003	2 DIODI 200mA 30V S.TKY IN SERIE SOT23 BAT54S	D1 D7 D10 D11 D12 D13 D14 D15 D17	9	9	9
38	H400000008	DIODO 150mA 75V MINI-MELT LL4148	D2 D3 D16	3	3	3
39	H400000010	S10 DO 214AC 1N4007 smd equivalent	D5	1	1	1
40	H430000005	TRANS 500mA 100V NPN SOT23 (BC17)	Q1 Q2 Q4 Q5 Q7 Q8	6	6	6
41	H440000002	TRANS 500mA 100V PNP SOT23 (BC107)	Q6	1	1	1
42	H460000020	2 OP-AMP LOW OFFset LM358AM	U2 U4	2	2	2
43	H460000021	4 OP-AMP 324 SOIC14 (LM324)	U1	1	1	1
44	H490000005	IC 68HC908QY4 SOIC16 (MC68HC908QY4)	U3	1	1	1
45	W2002500 OPPURE W2002502	SFERNICE POTENZIOMETRO 25K 20% LINEARE BOURNS	R60	1	1	1
46	W4021680	LED ROSSO D-5	D6	1	1	1
47	W4021690	LED VERDE D-5	D8	1	1	1
48	W4021700	LED GIALLO D-5	D9	1	1	1
49	W6300006	CONNA PERF.DIISOLANTE 16PIN M.90GR. x CS.	JP1	1	1	1
50	W6110104	CONNETTORE MODU2 4X1 AMP 90 GRADI 280378-1	JP2	1	1	1
51	W752E003	DEVIATORE LEV. ON/OFF/ON 1 POLO "ermetico"	SW1	1	1	1
52	W7500015	DIP SWITCH 4 POLI P=7.62	SW2	1	NM	NM
53	W7900010	VERNICE ISOLANTE 220	Q.B.	Q.B.	Q.B.	Q.B.
54	W70X0708	C.S.CONTROL BOARD V155 spess. EP=16mm/spess. Cu=35micron		1	1	1

CODICE	W05X0708	W05X0708-1	W05X0708-2
SPECIF. PROGRAMMAZIONE	H490000005-002D	H490000005-003A	H490000005-004A

SCHEMA ELETTRICO: X0708rev00
 SPECIFICA DI PROGRAMMAZIONE: VEDI "TABELLA DI PROGRAMMAZIONE"
 MANIPOLARE COME DA SPECIFICA DT0035
 SALDARE COME DA SPECIFICA DT0034
 PROCEDURA DI COLLAUDO DT0064 (DA APPLICARE SOLO IN CASO DI COLLAUDO FUNZIONALE MANUALE)
 PROCEDURA DI TEST FUNZIONALE DEL MICRO CONTROLLORE : DT0067 (DA APPLICARE SU COLLAUDO ICT PER VERIFICA CORRETTA PROGRAMMAZIONE).
 FASE 1
 NA - COMPONENTI DA NON MONTARE: C13, C21, C25, S.J1, S.J2, S.J3, S.J4, S.J5, S.J6, JP3. (SW2 SOLO PER W05X0708-1 E W05X0708-2)
 NB - RASARE I PIN DAL LATO SALDATURA.
 NC - OPZIONALE L'USO DI DISTANZIALI PER IL MONTAGGIO LED.
 ND - PROGRAMMARE IL MICROCONTROLLORE, DIPENDENTEMENTE DAL TIPO DI SCHEDA DA REALIZZARE, UTILIZZANDO LA "TABELLA DI PROGRAMMAZIONE".
 A FINE PROGRAMMAZIONE SEGNARE CON UN PALLINO BIANCO IL MICROCONTROLLORE (COME MOSTRATO DA IMMAGINE).
 SOLO PER LA PROGRAMMAZIONE IN-CIRCUIT: TUTTI I DIP SWITCHES DEVONO ESSERE SU OFF.
 NE - DOPO LA PROGRAMMAZIONE DELLA SCHEDA, IN CASO DI COLLAUDO IN CIRCUIT, SEGUIRE LA PROCEDURA DI VERIFICA DI CORRETTA PROGRAMMAZIONE DT0067.
 NF - APPLICARE SULLA SCHEDA (BOTTOM LAYER) UN' ETICHETTA CON INDICATI IL CODICE CORRETTO E LA RELATIVA SPECIFICA DI PROGRAMMAZIONE.
 FASE 2
 NG - VERNICIARE (IRIF:53) LA SCHEDA A SPRUZZO NELLE ZONE INDICATE, ISOLO LATO SALDATURA.
 NH - LA SCHEDA NON PUO' ESSERE MONTATA E NON SI PUO' ESEGUIRE IL TEST DIELETTICO PRIMA DI 24 ORE DALLA VERNICIATURA

SENZA SPECIFICA AUTORIZZAZIONE DI LINCOLN ELECTRIC ITALIA È VIETATA LA DIVULGAZIONE DEL PRESENTE DOCUMENTO.
 This sheet contains proprietary information owned by LINCOLN ELECTRIC ITALIA and is not to be reproduced, disclosed, or used without the express permission of LINCOLN ELECTRIC ITALIA

LINCOLN ELECTRIC ITALIA S.r.l.
SERRA RICCO' (GE), ITALIA

DESCRIZIONE
ASSEMBLAGGIO COMPONENTI
CONTROL BOARD V145-S / V155-S

DOVE NON SPECIFICATO LE QUOTE DISEGNO SONO ESPRESSE IN MILLIMETRI

SCALA NO DATA 12/07/2006
 TOLLERANZA: NO FOGLIO 2 DI 2
 DISEGN. D. Scaldaferrì APPR. NUMERO DI DISEGNO REV. **W05X0708 00**

NOTE: Lincoln Electric assumes no responsibility for liabilities resulting from board level troubleshooting. PC Board repairs will invalidate your factory warranty. **Individual Printed Circuit Board Components are not available from Lincoln Electric.** This information is provided for reference only. Lincoln Electric discourages board level troubleshooting and repair since it may compromise the quality of the design and may result in danger to the Machine Operator or Technician. Improper PC board repairs could result in damage to the machine.



Return to Section TOC
Return to Section TOC
Return to Section TOC
Return to Section TOC
Return to Section TOC
Return to Section TOC
Return to Section TOC
Return to Section TOC

Return to Master TOC

Return to Master TOC

Return to Master TOC

Return to Master TOC

PC BOARD ASSEMBLY - CONTROL BOARD - SHEET #2

Return to Section TOC
Return to Master TOC

Return to Section TOC
Return to Master TOC

Return to Section TOC
Return to Master TOC

Return to Section TOC
Return to Master TOC

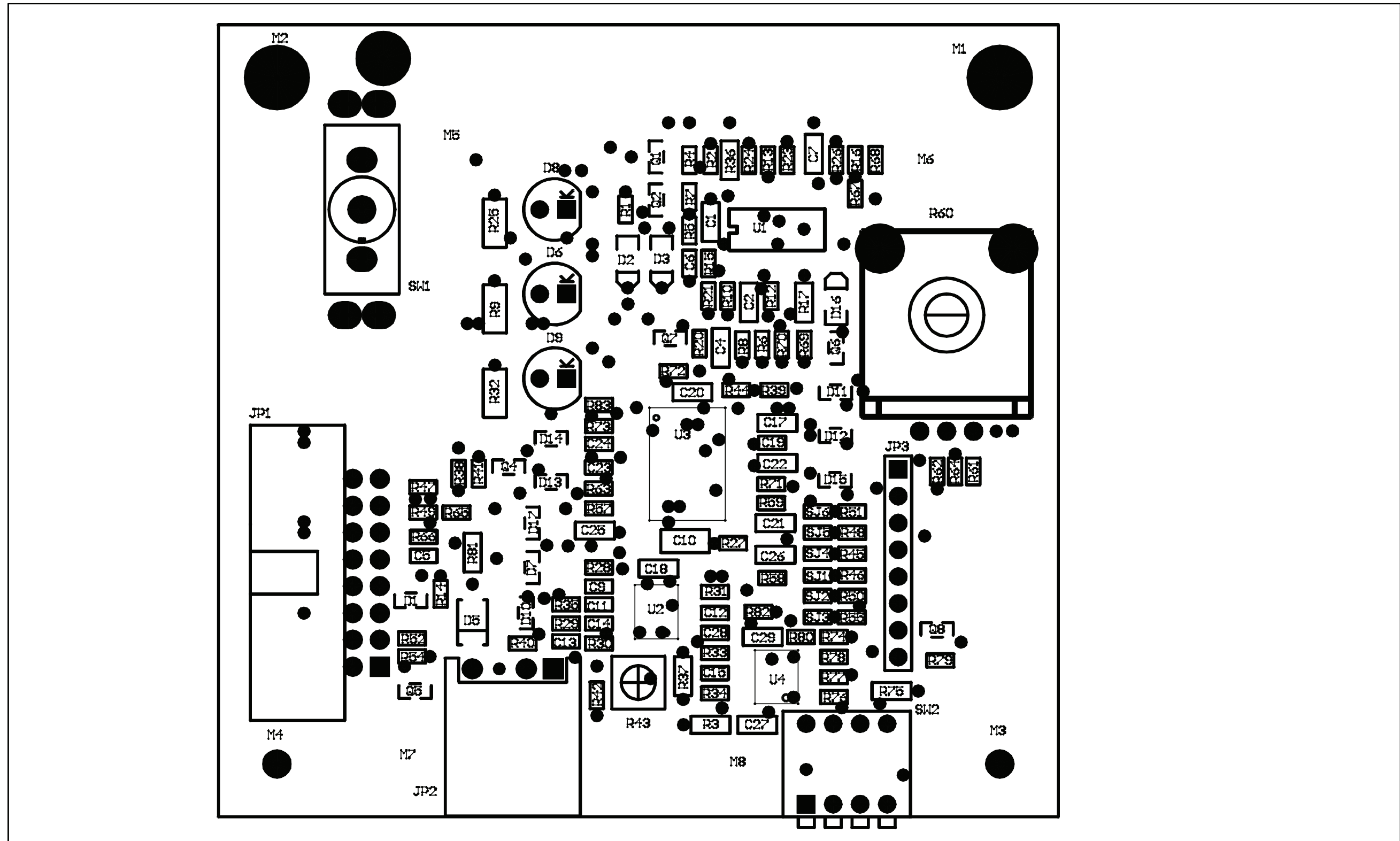

SENZA SPECIFICA AUTORIZZAZIONE DI LINCOLN ELECTRIC ITALIA È VIETATA LA DIVULGAZIONE DEL PRESENTE DOCUMENTO. This sheet contains proprietary information owned by LINCOLN ELECTRIC ITALIA and is not to be reproduced, disclosed, or used without the express permission of LINCOLN ELECTRIC ITALIA			
LINCOLN ELECTRIC ITALIA S.r.l. SERRA RICCO' (GE), ITALIA		DESCRIZIONE ASSEMBLAGGIO COMPONENTI CONTROL BOARD V145-S / V155-S	
DOVE NON SPECIFICATO LE QUOTE DISEGNO SONO ESPRESSE IN MILLIMETRI			
SCALA	NO	DATA	12/07/2006
DISEGN.	D. Scaldasferri	APPR.	
		TOLLERANZA:	NO
		FOGLIO 2 DI 2	
		NUMERO DI DISEGNO	REV.
		W05X0708	00

NOTE: Lincoln Electric assumes no responsibility for liabilities resulting from board level troubleshooting. PC Board repairs will invalidate your factory warranty. **Individual Printed Circuit Board Components are not available from Lincoln Electric.** This information is provided for reference only. Lincoln Electric discourages board level troubleshooting and repair since it may compromise the quality of the design and may result in danger to the Machine Operator or Technician. Improper PC board repairs could result in damage to the machine.



Free Manuals Download Website

<http://myh66.com>

<http://usermanuals.us>

<http://www.somanuals.com>

<http://www.4manuals.cc>

<http://www.manual-lib.com>

<http://www.404manual.com>

<http://www.luxmanual.com>

<http://aubethermostatmanual.com>

Golf course search by state

<http://golfingnear.com>

Email search by domain

<http://emailbydomain.com>

Auto manuals search

<http://auto.somanuals.com>

TV manuals search

<http://tv.somanuals.com>