



Dual Rail Modular KVM Console with 15 / 17 / 19" LCD Panel

User Manual

English

For Installation into a 19" rack it is essential to precisely follow the installation procedure as described in section

3.1. Install the Console into a Cabinet
of this manual.



Tested to comply with FCC Standards
For Commercial Use Only!

Packing List

The complete 15 / 17 / 19" dual rail console for modular KVM switch package consists of:

- 1U 19" rack mount console
- Rail with front and rear bracket x 2
- Blockers x 2
- 1.8 m KVM cable. (HDDDB-15 / VGA + PS/2 x 2)
- AC to DC power adapter
- User Guide CD
- Quick installation guide
- Key x 2
- Flat screws (length 6mm) x 6
- Screws (to combine blockers and console) x 2

Please read this manual thoroughly, and follow the installation and operation procedures carefully to prevent any damage to the product, and / or any of the devices that connect to it.

Safety Instructions

1. Please read these safety instructions carefully.
2. Please keep this User's Manual for later reference.
3. Please disconnect this equipment from the AC outlet before cleaning. Do not use liquid or sprayed detergent for cleaning. Use a moist sheet or cloth for cleaning.
4. It is recommended that for your convenience the equipment is installed near an easily accessible power socket.
5. Please keep this equipment in a non-humid environment.
6. Before starting the installation ensure that your equipment is situated on a stable, level surface. A drop or fall could cause injury.
7. Do not leave this equipment in an unconditioned environment, storage temperatures above 60 °C or humidity may damage to the equipment.
8. The opening on the enclosure is for air convection, to prevent the equipment from overheating. **DO NOT COVER THE OPENING.**
9. Ensure that the voltage of the power source you are connecting to the equipment matches the supported input voltage.
10. Please keep the power cord in such a way that people can not step or trip on it. Do not place anything over power cord. The power cord must be correctly rated for the voltage and current marked on the product's electrical ratings label. The voltage and current rating of the cord should be greater than the voltage and the current rating marked on the product.
11. All cautions and warning on the equipment **MUST** be noted.
12. If the equipment is not in use for a long period, disconnect the equipment from the mains to avoid being damaged by transient over-voltage.
13. Never pour any liquid into the ventilation openings; this could cause a fire or an electrical shock.
14. Never open the equipment. For safety, **ONLY** qualified service personnel should open the equipment.
15. If one of the following situations arises, get the equipment checked by service personnel.
 - The power cord or plug is damaged.
 - The equipment has been exposed to moisture.
 - The equipment has not worked well or you can not get it to work according to this User Manual.
 - The equipment has been dropped or damaged.
 - If the equipment shows obvious signs or breakage.

Index of Contents

Packing List	1
Safety Instructions	2
Index of Contents	3
1. General Information.....	4
1.1 Features	4
1.2 Benefits	4
1.3 Product Specification	5
1.3.1 15" Dual Rail Console with Modular KVM Switch Specification	5
1.4.2 17" Dual Rail Console with Modular KVM Switch Specification	6
1.4.3 19" Dual Rail Console with Modular KVM Switch Specification	7
2. Panel Controls & OSD Function.....	8
2.1 Auto Tune.....	8
2.2 Input Source	8
2.3 Brightness	9
2.4 Contrast.....	9
2.5 Colour.....	9
2.6 Position	10
2.7 Language	10
2.8 Reset to Factory Settings.....	10
2.9 Power Indicator	10
3. Installation	11
3.1 Install Console into Cabinet	11
3.1.1 Notes.....	11
3.1.2 Hardware Kits Contents.....	11
3.1.3 Installing the Console	112
3.2 Install Modular KVM Switch	13
3.2.1 Hardware Kits Contents.....	13
3.2.2 Install Modular KVM Switch Step.....	13
3.3 Installing the Video Card and Video Driver	15
3.3.1 Configuring the Display Settings.....	15
3.3.2 Connecting the Console.....	16
3.4 Turning the Console On	16
3.5 Testing the Console	16
4. KVM Switch	17

1. General Information

The LINDY Dual Rail consoles offer an industrial level input solution to optimize your space utilization by controlling your systems in just 1U. With the unique modular design, you can easily integrate with more than 17 models of KVM switch, with different functions, and expand up to 8 levels of KVM switch.

1.1. Features

- Patented Dual Rail design for independent Panel and Keyboard drawer
- Hidden handle for keyboard drawer
- 15, 17 & 19" LCD panel options
- Support Sun native resolutions (17" & 19")
- Support 17 keyboard languages
- Bright Active TFT display
- OSD function for LCD display and KVM switch
- Durable keyboard (touchpad, cherry keyboard or optical trackball)
- Panel protected by tempered glass
- Integration with more than 17 models of KVM switch
- DC power, DVI, USB, Touch panel (optional)
- Sun keys (optional)

1.2. Benefits

Patented Dual Rail design:

The user can leave the LCD flip over, push back the keyboard drawer, and close the cabinet door.

Hidden handle:

After pushing the keyboard drawer back, the handle of the keyboard drawer can also be hidden and offer a flat surface for the cabinet.

Patented extension bracket:

With the patented extension bracket, the console body can extend 13cm. Even if there is a large server handle or patch panel above the console it will still provide over 90 degrees of viewing angle.

Modular KVM switches:

You can use the console as a single port console, however due to it's modular design is very easy to add 8 / 16 or even 32 port KVM consoles, with little time or effort.

1.3. Product Specification

1.3.1. 15" Dual Rail Console with Modular KVM Switch Specification

Model name	15" dual rail console with modular KVM switch
Number of ports	1
Dimension	459.6 x 448.3 x 44 mm / 18.1 x 17.6 x 1.7 inches
Package Dimension	606 x 551.5 x 230 mm / 23.9 x 21.7 x 9.0 inches
Net Weight	12 Kg / 26.5 lbs
Gross Weight	19.5 Kg / 43.0 lbs
Display Size	15 inches
Panel Type	Active Matrix TFT LCD
Resolution Capabilities	Maximum Resolution up to 1024 x 768 (XGA)
Pixel Pitch	Supports 0.297 mm x 0.297 mm
Viewing Angle (CR>10)	Right-Left view 130°(Typ): Up-Down View 100°(Typ)
Contrast Ratio	400:1
Brightness	White 250 cd/m2
Back Light	Dual Lamps for Back Light
Supported Colors	16.7M Colors (8-bit with FRC)
Response Time	Rising Time 5 ms, Decay Time 11 ms
Operating System	Dos, Windows (3.1, 9x, 2000, NT4, ME, XP, 2003 Server) Linux, Novell 3.12-6, HP UX, SUN
Multi Platform	Support PS/2 and USB
System Cables	VGA + PS/2 x 2 or VGA + USB x 1 cable
Keyboard Mouse	106 key PS/2 keyboard with touch pad
Sync	45 ~ 80 KHz
Power Source	100 ~ 240 VAC input
Power Consumption	16W, 10.41W for Panel
Temperature	Operate 0 ~ 50°C / 32 ~ 122°F Storage -20 ~ 60°C / -4 ~ 140°F
Humidity	10% ~ 90% RH
Chassis Construction	Heavy duty steel materials
Keyboard Language	USA, UK, German, French, Spanish, Italian, Portuguese, Dutch, Swiss, Belgium, Swedish, Norwegian, Danish, Japan, Taiwan, Russian, Hebrew
Certification	CE / FCC, UL / CUL / C-Tick, GOST

15" Dual Rail Console with Modular KVM Switch Dimensions

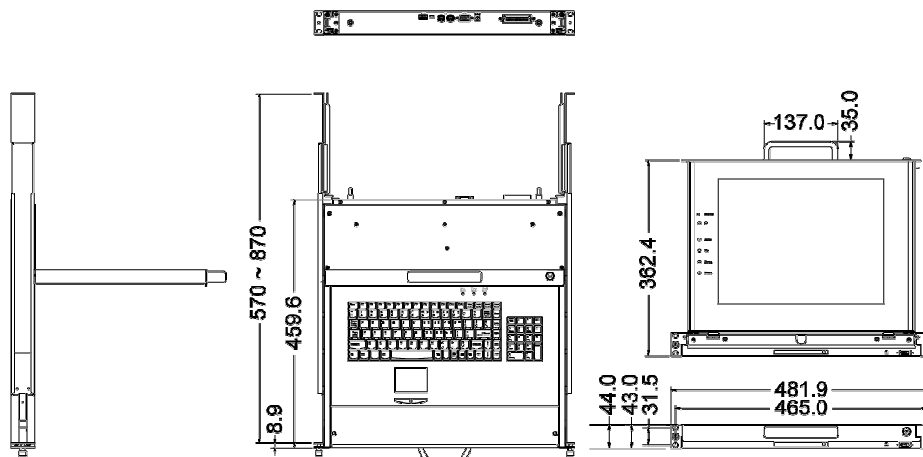

1.3.2. 17" Dual Rail Console with Modular KVM Switch Specification

Model name	17" dual rail console with modular KVM switch
Number of ports	1
Dimension	459.6 x 448.3 x 44 mm / 18.1 x 17.6 x 1.7 inches
Package Dimension	606 x 551.5 x 230 mm / 23.9 x 21.7 x 9.0 inches
Net Weight	13 Kg / 28.7 lbs
Gross Weight	20.5 Kg / 45.2 lbs
Display Size	17 inches
Panel Type	Active Matrix TFT LCD
Resolution Capabilities	Maximum Resolution up to 1280 x 1024 (SXGA)
Pixel Pitch	Supports 0.264 mm x 0.264 mm
Viewing Angle (CR>10)	Right-Left view 60° ~ 70°(Typ): Up-Down View 45° ~ 60°(Typ)
Contrast Ratio	450:1
Brightness	White 250 cd/m2
Back Light	Quad Lamps for Back Light
Supported Colors	16.7M Colors (8-bit with FRC)
Response Time	Rising Time 2 ms, Decay Time 14 ms
Operating System	Dos, Windows (3.1, 9x, 2000, NT4, ME, XP, 2003 Server) Linux, Novell 3.12-6, HP UX, SUN
Multi Platform	Support PS/2 and USB
System Cables	VGA + PS/2 x 2 or VGA + USB x 1 cable
Keyboard Mouse	106 key PS/2 keyboard with touch pad
Sync	45 ~ 80 KHz
Power Source	100 ~ 240 VAC input
Power Consumption	25W, 19.05W for Panel
Temperature	Operate 0 ~ 50°C / 32 ~ 122°F Storage -20 ~ 60°C / -4 ~ 140°F
Humidity	10% ~ 90% RH
Chassis Construction	Heavy duty steel materials
Keyboard Language	USA, UK, German, French, Spanish, Italian, Portuguese, Dutch, Swiss, Belgium, Swedish, Norwegian, Danish, Japan, Taiwan, Russian, Hebrew
Certification	CE / FCC, UL / CUL / C-Tick, GOST

17" Dual Rail Console with Modular KVM Switch Dimensions

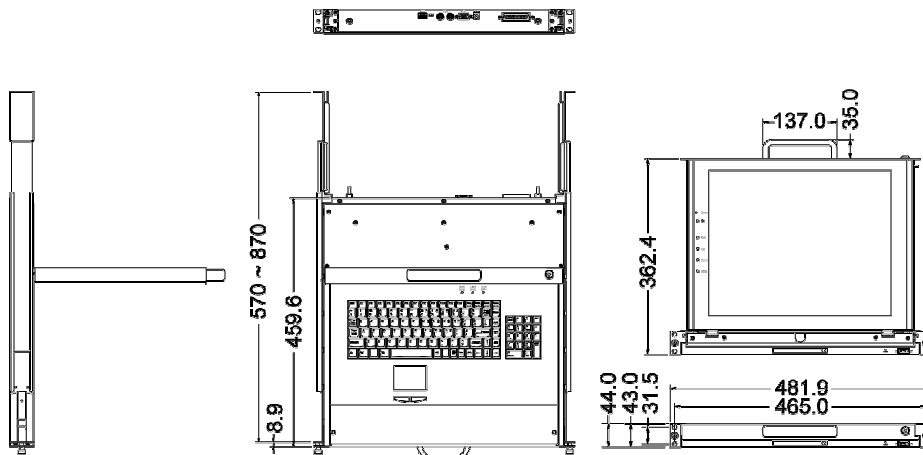

1.3.3. 19" Dual Rail Console with Modular KVM Switch Specification

Model name	19" dual rail console with modular KVM switch
Number of ports	1
Dimension	539.6 x 448.3 x 44 mm / 21.2 x 17.6 x 1.7 inches
Package Dimension	606 x 551.5 x 230 mm / 23.9 x 21.7 x 9.0 inches
Net Weight	13 Kg / 28.7 lbs
Gross Weight	21.5 Kg / 47.4 lbs
Display Size	19 inches
Panel Type	Active Matrix TFT LCD
Resolution Capabilities	Maximum Resolution up to 1280 x 1024 (SXGA)
Pixel Pitch	Supports 0.098 mm x 0.294 mm
Viewing Angle (CR>10)	Right-Left view 140°(Typ): Up-Down View 140°(Typ)
Contrast Ratio	500:1
Brightness	White 250 cd/m ²
Back Light	Quad Lamps for Back Light
Supported Colors	16.7M Colors (8-bit with FRC)
Response Time	Rising Time 2 ms, Decay Time 10 ms
Operating System	Dos, Windows (3.1, 9x, 2000, NT4, ME, XP, 2003 Server) Linux, Novell 3.12-6, HP UX, SUN
Multi Platform	Support PS/2 and USB
System Cables	VGA + PS/2 x 2 or VGA + USB x 1 cable
Keyboard Mouse	106 key PS/2 keyboard with touch pad
Sync	45 ~ 80 KHz
Power Source	100 ~ 240 VAC input
Power Consumption	25W, 21.05W for Panel
Temperature	Operate 0 ~ 50 °C / 32 ~ 122 °F Storage -20 ~ 60 °C / -4 ~ 140 °F
Humidity	10% ~ 90% RH
Chassis Construction	Heavy duty steel materials
Keyboard Language	USA, UK, German, French, Spanish, Italian, Portuguese, Dutch, Swiss, Belgium, Swedish, Norwegian, Danish, Japan, Taiwan, Russian, Hebrew
Certification	CE / FCC, UL / CUL / C-Tick, GOST

19" Dual Rail Console with Modular KVM Switch Dimensions

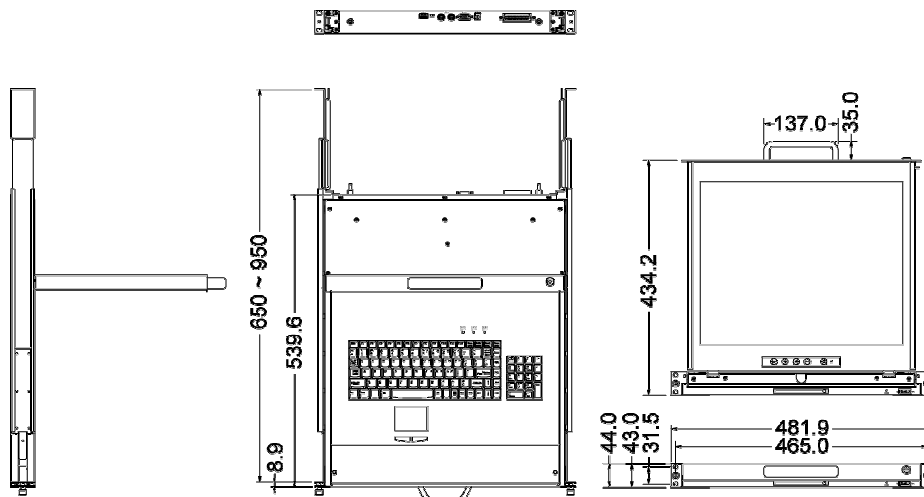

2. Panel Controls & OSD Function

Panel Controls	Description
	Soft power on/off button. Adjacent LED is lit when on
Auto	Auto-synchronize and scale down display to any valid factory preset timings
Up ▲	Press to scroll the function you want to adjust
Down ▼	Press to scroll the function you want to adjust
Menu	To access the main menu. This button also acts as the “Enter” button

2.1. Auto Tune

1. Press **Menu**
2. Use the **Up** and **Down** buttons to scroll to **Auto Tune**
 - Auto tune**
 - Input Source
 - Brightness
 - Contrast
 - Color
 - Position
 - Language
 - Recall
 - Exit
3. Press **Menu** to select **Auto Tune**
4. The panel will adjust the display size automatically and also tune the panel to its best condition

2.2. Input Source

1. Press **Menu**
2. Use the **Up** and **Down** buttons to scroll to **Input Source**
 - Auto tune
 - Input Source**
 - Brightness
 - Contrast
 - Color
 - Position
 - Language
 - Recall
 - Exit
3. Press **Menu** to enter
4. Use the **Up** and **Down** buttons to scroll to the signal input source.
5. Press **Menu** to enter

2.3. Brightness

1. Press **Menu**
2. Use the **Up** and **Down** buttons to scroll to **Brightness**
3. Press **Menu** to enter
4. Use the **Up** and **Down** buttons to adjust the Brightness of the display
5. Press **Menu** to enter

2.4. Contrast

1. Press **Menu**
2. Use the **Up** and **Down** buttons to scroll to **Contrast**
3. Press **Menu** to enter
4. Use the **Up** and **Down** buttons to adjust the Contrast of the display
5. Press **Menu** to enter

2.5. Colour

1. Press **Menu**
2. Use the **Up** and **Down** buttons to scroll to **Color**
3. Press **Menu** to enter. You will see:

Icon	Description
9300 °K	To set CIE coordinates at 9300 °K color
7500 °K	To set CIE coordinates at 7500 °K color
6500 °K	To set CIE coordinates at 6500 °K color
User	To set user defined CIE
Auto color	To auto adjust color
Return	To exit and return to the previous page

4. Use the **Up** and **Down** buttons to adjust the Colour of the display
5. Press **Menu** to enter

2.6. Position

1. Press **Menu**
2. Use the **Up** and **Down** buttons to scroll to **Positioning**
3. Press **Menu** to enter. You will see:

Icon	Description
Image Pos	To adjust the position of the image.
OSD Pos	To adjust the position of the OSD.
Return	To exit and return to the previous page

4. Use the **Up** and **Down** buttons to choose which Position you want to change
5. Press **Menu** to enter

2.7. Language

1. Press **Menu**
2. Use the **Up** and **Down** buttons to scroll to **Language**
3. Press **Menu** to enter. You will see:

English

German

French

Italian

Spanish

4. Use the **Up** and **Down** buttons to scroll to highlight your preferred language
5. Press **Menu** to enter

2.8. Reset to Factory Settings

1. Press **Menu**
2. Use the **Up** and **Down** buttons to scroll to **Recall**
3. Press **Menu** to enter. You will see:

Yes/ No

4. Use the **Up** and **Down** buttons to scroll, select **Yes** then press **Menu** to reset to factory settings. Select **No** to return to the previous page.

2.9. Power Indicator

- ◆ GREEN ON
- ◆ RED STANDBY
- ◆ RED SUSPEND
- ◆ RED OFF

3. Installation

3.1. Install the Console into a Cabinet

3.1.1. Notes

It is essential that each step of this installation guide is completed in the stated order to ensure a successful installation. It is highly recommended that two persons carry out the installation.

1. Please the contents of this box against the list below, before installation.
2. Before installation, make sure all peripherals and computer have been turned off.
3. The cabinet depth range must be in 570 ~ 870 mm for the 15" and 17" console or 650 ~ 950 mm for the 19" console.
4. Reliable earthing of rack-mounted equipment must always be maintained. Particular attention should be given to supply connections other than direct connections to the branch circuit.

3.1.2. Hardware Kits Contents

1. Rail with front and rear bracket x 2

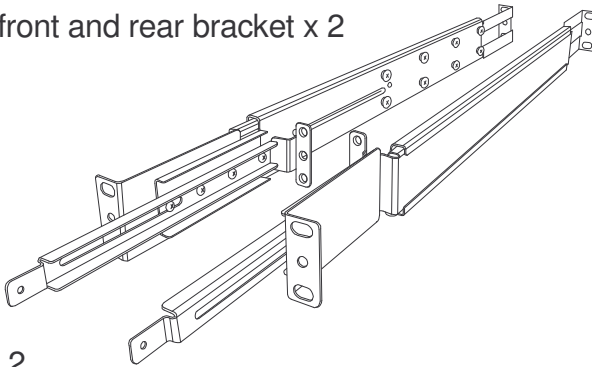

2. Blocker x 2

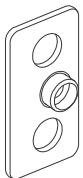

Old version (2007)

New version (2008)

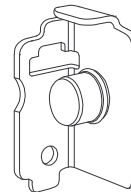

3. Screw x 2



4. Screw (length = 6 mm) x 6



5. Key x 2

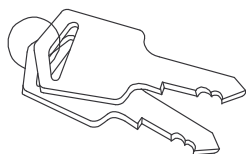

3.1.3. Installing the Console

1. Adjust the rail with the rear bracket to fit your cabinet

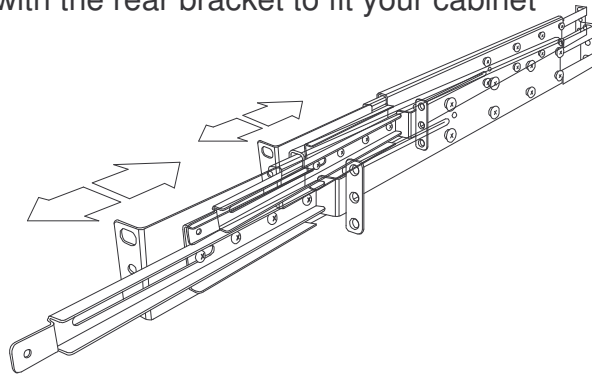

2. Attach the front and rear brackets to your cabinet

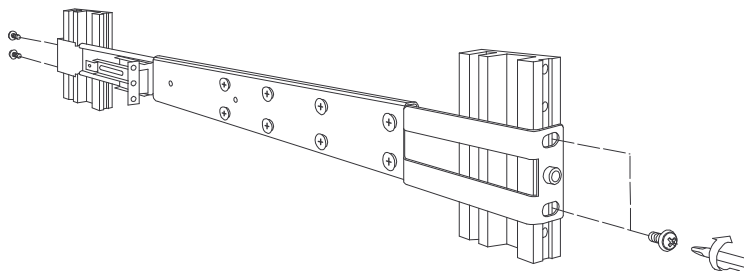

3. Repeat steps 1 and 2 for the other side of your cabinet
4. Slide the console along the rails until you reach the end

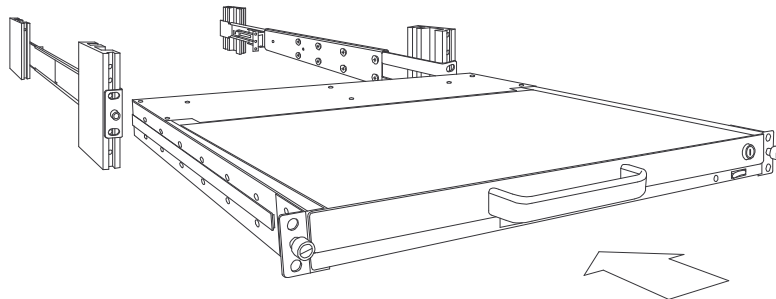

5. Use a screw to connect the blocker to the rear of the console at each side

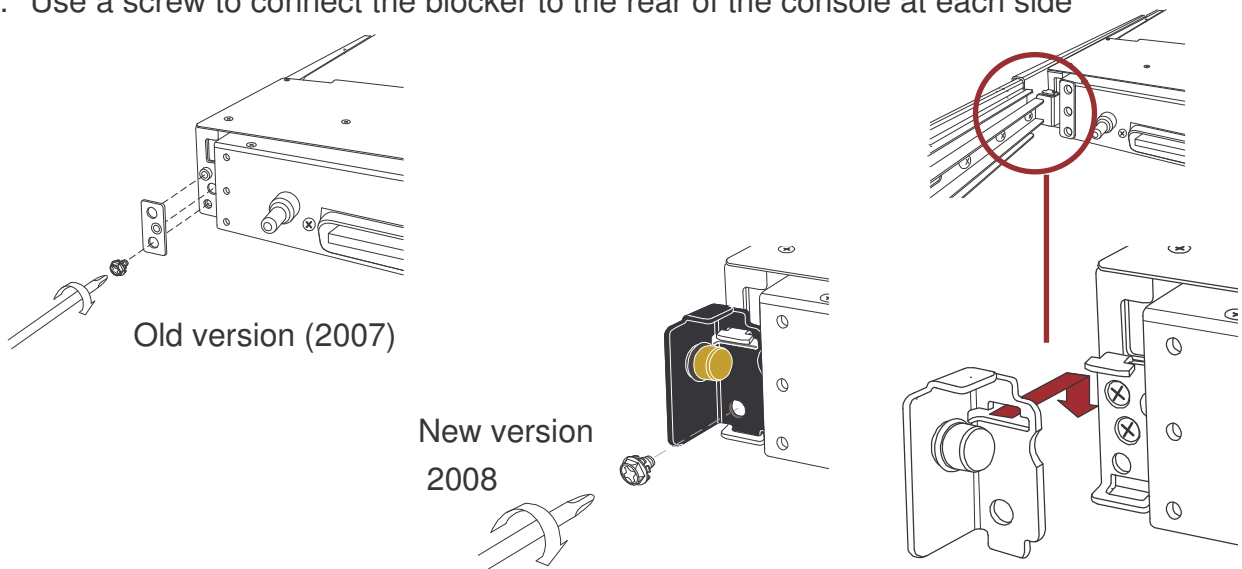

6. Install three screws (length 6mm) to the rear of the console at each side to complete the installation

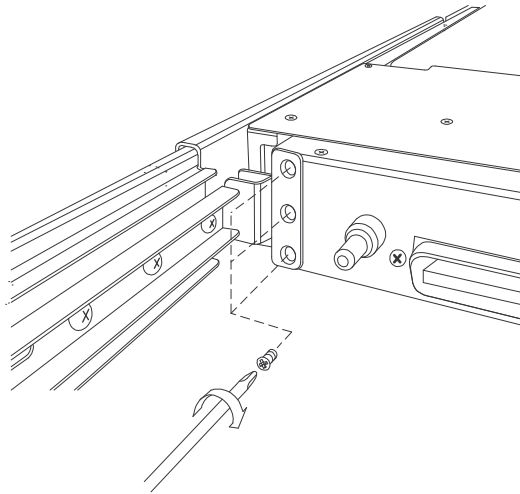

3.2. Install Modular KVM Switch (OPTIONAL MODULE)

3.2.1. Hardware Kits Contents

1. Bracket A with thumb screw x 2

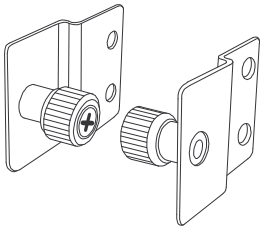

2. Screw (length 6 mm) x 4



3.2.2. Install Modular KVM Switch Step

1. Install two screws (length 6mm) to attach Bracket A to the KVM Switch at each side

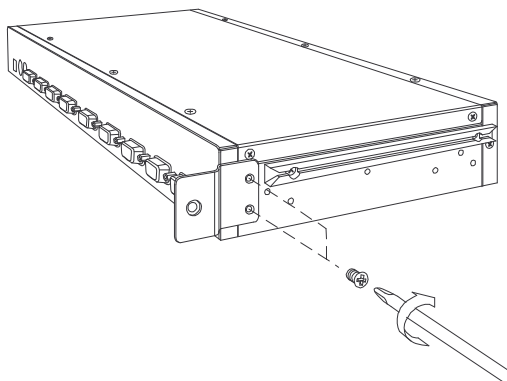

- From the rear of the cabinet slide the KVM Switch along the rails, until it reaches the console and the thumb screws are aligned to the rear of the cabinet

Plastic Rail on KVM Switch

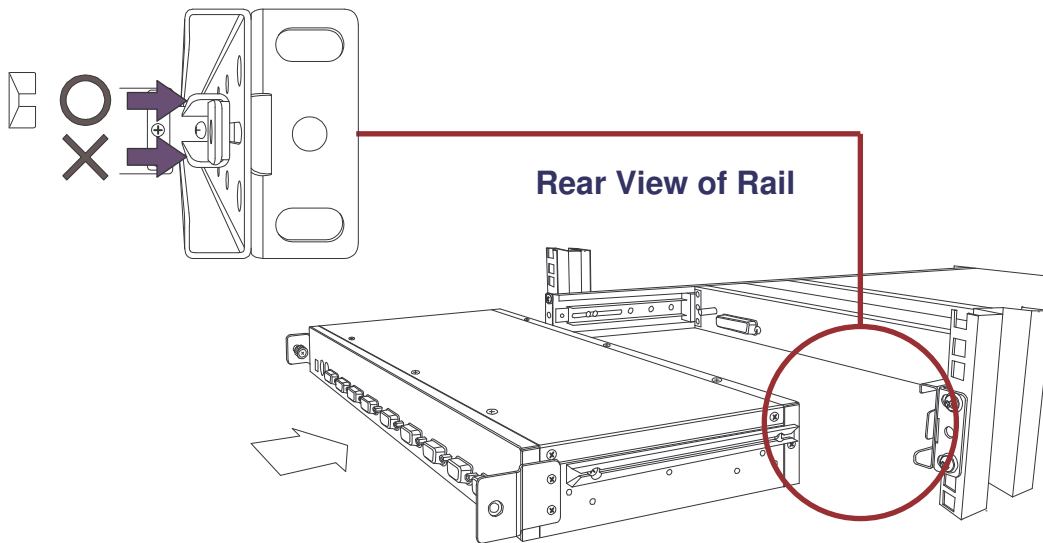

- Tighten the Thumb Screws of Bracket A, at each side, to fix the position of the KVM Switch and complete the installation

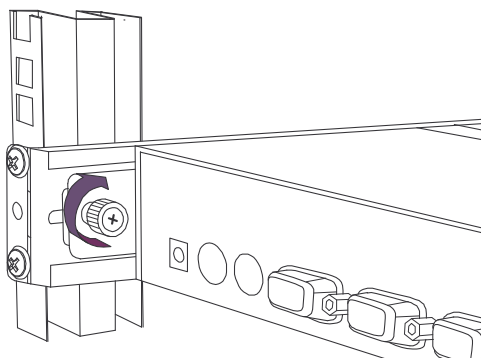

3.3. Installing the Video Card and Video Driver

Before connecting the LCD console, make sure your computer has a video card already installed for the monitor. After you connect the console, install the video driver. The video driver is supplied by the video card manufacturer and may be found on the CD-ROM that came with your computer. If you need information on installing a video card or video driver, refer to the manual that came with your video card.

3.3.1. Configuring the Display Settings

After connecting the console and turning on your computer, you may need to configure one or more of the following display settings:

- Display mode (also called desktop area or video resolution)
- Refresh rate (also called vertical scan rate or vertical sync)
- Color depth (also called color palette or number of colors)

Each video card has several controls that let you adjust the display settings. However, the software and driver for each video card is unique. In most cases, you adjust these settings by using a program or utility provided by the manufacturer of the video card. Most video cards use the Windows Display Properties control panel to configure the display. To open the Windows Display Properties, click the right mouse button in a blank area of the Windows desktop and then select **Properties**. The Settings tab lets you change the Color Palette and the Desktop Area (*x by y* pixel resolution).

Some video cards integrate additional features into the Windows Display Properties control panel to give you an exceptional setup that is flexible and easy to use. For example, the control panel may include an Advanced Properties button, an Adjustment tab, or a Refresh tab for changing other settings. Other video cards have a separate utility for setting display properties.

Whenever you change the resolution, color, or refresh rate, the image size, position, or shape may change. This behavior is normal. You can readjust the image using the monitor on-screen controls. For more information on the monitor on-screen controls, refer to Chapter 2. For more information on configuring the display settings, refer to the manual that came with your video card.

3.3.2. Connecting the Console

To connect an LCD console to a computer, perform the following steps

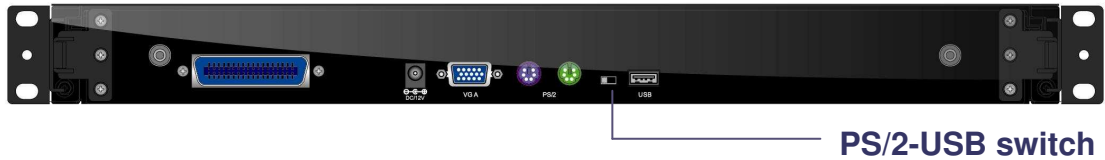

1. Turn off your computer. You should always turn off your computer before connecting or disconnecting a device.
2. Connect the video (VGA) connector of the KVM cable to the video card connector on the rear panel of your computer.
3. Identify and connect the PS/2 mouse and PS/2 keyboard connector to the correct PS/2 ports on the rear panel of your computer, or if you prefer you can use the USB interface to connect your computer. Use PS/2-USB switch (highlighted above) to select your interface.

Please Note: Do not connect PS/2 and USB cables at the same time!

4. Connect the AC to DC power adapter to the power inlet on the console and then to a power outlet.

3.4. Turning the Console On

Make sure that the AC to DC power adapter and all other cables are connected properly. Be sure to tighten all connector screws. Using two hands, grasp the rear of the console, lift the tab and pull the panel up and forward. This will disengage the momentary on / off switch and the unit should power on. The LED on the left or under of the monitor panel should turn from orange to green, verifying that the unit is operational.

3.5. Testing the Console

To test that the console is working properly, perform the following steps:

1. Power up the console, and then turn on your computer
2. If the unit does not power up when the panel is pulled up, try pushing the soft power on/off button on the left or under side of the monitor panel to power up the unit.
3. Make sure the video image is centered within the screen area. Use the OSD controls to adjust the image (see note below) or press the Auto button on the right hand side of the monitor.

Please Note: You can adjust the horizontal and vertical position, contrast, and brightness to

better suit your video card and your personal preference. Refer to Chapter 2 for more information on using the on-screen menu to adjust the video display. Before you begin, make sure that powers to all the devices you will be connecting up have been turned off. To prevent damage to your installation due to ground potential difference, make sure that all the devices on the installation are properly grounded.

4. KVM Switch

With a unique modular design, you can easily integrate different KVM switch models, with different functions, and expand them up to 8 levels of KVM switch with a total number of up to 128 servers to manage.

Compatible KVM Switches from the LINDY range are:

KVM Switch U8C Modular – No. 39530 *

KVM Switch U16C Modular – No. 39531 *

* These two models can easily be expanded by using a simple slide-in-module to provide a remote access dual user option for a) KVM over IP access module or b) Cat.5 KVM Extender remote user station

Further models are under development – Please check the LINDY website www.lindy.com for up to date information and new products.

Please refer to the user guide supplied with your KVM switch for information on installation and operation.

For Installation of the KVM Switch module it is essential to follow the installation procedure as described in section 3.2. Install Modular KVM Switch (OPTIONAL MODULE) of this manual.

WEEE, Recycling of Electronic Products (Europe)



WEEE (Waste of Electrical and Electronic Equipment), Recycling of Electronic Products

In 2006 the European Union introduced regulations (WEEE) for the collection and recycling of all waste electrical and electronic equipment. It is no longer allowable to simply throw away electrical and electronic equipment. Instead, these products must enter the recycling process.

Each individual EU member state has implemented the WEEE regulations into national law in slightly different ways. Please follow your national law when you want to dispose of any electrical or electronic products.

More details can be obtained from your national WEEE recycling agency.

Germany / Deutschland

Die Europäische Union hat mit der WEEE Richtlinie umfassende Regelungen für die Verschrottung und das Recycling von Elektro- und Elektronikprodukten geschaffen. Diese wurden von der Bundesregierung im Elektro- und Elektronikgerätegesetz – ElektroG in deutsches Recht umgesetzt. Dieses Gesetz verbietet vom 24. März 2006 an das Entsorgen von Elektro- und Elektronikgeräten über die Hausmülltonne!

B2B Geräte wie dies LINDY LCD Terminal und LINDY 19“ KVM Switches nimmt LINDY kostenlos zurück und führt sie einem geordneten Recycling entsprechend den gesetzlichen Vorgaben zu. Bitte nehmen Sie hierzu Kontakt mit LINDY auf, die Kontaktadressen finden Sie stets auf der LINDY Website www.lindy.com

B2C-Geräte müssen den lokalen Sammelsystemen bzw. örtlichen Sammelstellen zugeführt werden! Dort werden sie kostenlos entgegen genommen. Die Kosten für den weiteren Recyclingprozess übernimmt die Gesamtheit der Gerätehersteller.

Radio Frequency Energy, Certifications

Shielded cables must be used with this equipment to maintain compliance with radio frequency energy emission regulations and ensure a suitably high level of immunity to electromagnetic disturbances.

FCC Warning

This equipment has been tested and found to comply with the limits for a Class B digital device, pursuant to part 15 of the FCC Rules. These limits are designed to provide reasonable protection against harmful interference in a residential installation.

This equipment generates, uses, and can radiate radio frequency energy and, if not installed and used in accordance with the instructions, may cause harmful interference to radio communications. However, there is no guarantee that interference will not occur in a particular installation. If this equipment does cause harmful interference to radio or television reception, which can be determined by turning the equipment off and on, the user is encouraged to try to correct the interference by one or more of the following measures:

- Reorient or relocate the receiving antenna
- Increase the separation between the equipment and receiver
- Connect the equipment into an outlet on a circuit different from that to which the receiver is connected
- Consult the dealer or an experienced technician for help

You are cautioned that changes or modification not expressly approved by the party responsible for compliance could void your authority to operate the equipment.

This device complies with part 15 of the FCC Rules.

Operation is subject to the following two conditions:

1. This device may not cause harmful interference, and
2. This device must accept any interference received, including interference that may cause undesired operation.



Tested to comply with FCC Standards
For Commercial Use Only!

2nd Edition, July 2008

www.lindy.com

Free Manuals Download Website

<http://myh66.com>

<http://usermanuals.us>

<http://www.somanuals.com>

<http://www.4manuals.cc>

<http://www.manual-lib.com>

<http://www.404manual.com>

<http://www.luxmanual.com>

<http://aubethermostatmanual.com>

Golf course search by state

<http://golfingnear.com>

Email search by domain

<http://emailbydomain.com>

Auto manuals search

<http://auto.somanuals.com>

TV manuals search

<http://tv.somanuals.com>