

The Benchmark for Value in CCTV

INSTALLATION MANUAL

English version 1.0



DHU500 SERIES

MPEG4 Networkable DVR

DIGIMERGE™



Thank you for purchasing the DHU500 Series DVR. Digimerge is committed to providing our customers with a high quality, reliable security product.

The DHU500 Series line of Pentaplex Network DVR's offer a full-featured Networkable video recording solution. Record in Real Time with 120 fps recording capability. Images can be easily transferred using the built in CDRW optical drive or USB flash drive. The system can be viewed and controlled over the internet from a remote location with a password protected browser-based application. Easy access via the Free Digimerge DDNS Service is included.

To learn more about this DHU500 Series DVR, and to learn about our complete range of accessory products, please visit our website at:

<http://www.digimerge.com>



CAUTION

RISK OF ELECTRIC SHOCK
DO NOT OPEN



CAUTION: TO REDUCE THE RISK OF ELECTRIC SHOCK
DO NOT REMOVE COVER (OR BACK).
NO USER SERVICEABLE PARTS INSIDE.
REFER SERVICING TO A QUALIFIED SERVICE PERSONNEL



The lightning flash with arrowhead symbol, within an equilateral triangle, is intended to alert the user to the presence of uninsulated "dangerous voltage" within the product's enclosure that may be of sufficient magnitude to constitute a risk of electric shock to persons.



The exclamation point within an equilateral triangle is intended to alert the user to the presence of important operating and maintenance (servicing) instructions in the literature accompanying the appliance.

**WARNING: TO PREVENT FIRE OR SHOCK HAZARD,
DO NOT EXPOSE THIS UNIT TO RAIN OR MOISTURE.**

**CAUTION: TO PREVENT ELECTRIC SHOCK, MATCH WIDE BLADE
OF PLUG TO WIDE SLOT, FULLY INSERT.**



Important Safeguards

In addition to the careful attention devoted to quality standards in the manufacture process of your video product, safety is a major factor in the design of every instrument. However, safety is your responsibility too. This sheet lists important information that will help to assure your enjoyment and proper use of the video product and accessory equipment. Please read them carefully before operating and using your video product.

Installation

1. **Read and Follow Instructions** - All the safety and operating instructions should be read before the video product is operated. Follow all operating instructions.
2. **Retain Instructions** - The safety and operating instructions should be retained for future reference.
3. **Heed Warnings** - Comply with all warnings on the video product and in the operating instructions.
4. **Polarization** - Do not defeat the safety purpose of the polarized or grounding-type plug.

A polarized plug has two blades with one wider than the other.

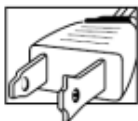

A grounding type plug has two blades and a third grounding prong.

The wide blade or the third prong are provided for your safety.

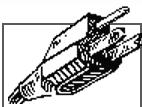

If the provided plug does not fit into your outlet, consult an electrician for replacement of the obsolete outlet

5. **Power Sources** - This video product should be operated only from the type of power source indicated on the marking label. If you are not sure of the type of power supply to your location, consult your video dealer or local power company. For video products intended to operate from battery power, or other sources, refer to the operating instructions.
6. **Overloading** - Do not overload wall outlets of extension cords as this can result in the risk of fire or electric shock. Overloaded AC outlets, extension cords, frayed power cords, damaged or cracked wire insulation, and broken plugs are dangerous. They may result in a shock or fire hazard. Periodically examine the cord, and if its appearance indicates damage or deteriorated insulation, have it replaced by your service technician.
7. **Power-Cord Protection** - Power supply cords should be routed so that they are not likely to be walked on or pinched by items placed upon or against them, paying particular attention to cords at plugs, convenience receptacles, and the point where they exit from the video product.

8. **Ventilation** - Slots and openings in the case are provided for ventilation to ensure reliable operation of the video product and to protect it from overheating. These openings must not be blocked or covered. The openings should never be blocked by placing the video equipment on a bed, sofa, rug, or other similar surface. This video product should never be placed near or over a radiator or heat register. This video product should not be placed in a built-in installation such as a bookcase or rack unless proper ventilation is provided or the video product manufacturer's instructions have been followed.

9. **Attachments** - Do not use attachments unless recommended by the video product manufacturer as they may cause a hazard.

10. **Water and Moisture** - Do not use this video product near water. For example, near a bath tub, wash bowl, kitchen sink or laundry tub, in a wet basement, near a swimming pool and the like.

Caution: Maintain electrical safety. Powerline operated equipment or accessories connected to this unit should bear the UL listing mark of CSA certification mark on the accessory itself and should not be modified so as to defeat the safety features. This will help avoid any potential hazard from electrical shock or fire. If in doubt, contact qualified service personnel.

11. **Accessories** - Do not place this video equipment on an unstable cart, stand, tripod, or table. The video equipment may fall, causing serious damage to the video product. Use this video product only with a cart, stand, tripod, bracket, or table recommended by the manufacturer or sold with the video product. Any mounting of the product should follow the manufacturer's instructions and use a mounting accessory recommended by the manufacturer.





Service

13. **Servicing** - Do not attempt to service this video equipment yourself as opening or removing covers may expose you to dangerous voltage or other hazards. Refer all servicing to qualified service personnel.
14. **Conditions Requiring Service** - Unplug this video product from the wall outlet and refer servicing to qualified service personnel under the following conditions.
 - A. When the power supply cord or plug is damaged.
 - B. If liquid has been spilled or objects have fallen into the video product.
 - C. If the video product has been exposed to rain or water.
 - D. If the video product does not operate normally by following the operating instructions. Adjust only those controls that are covered by the operating instructions. Improper adjustment of other controls may result in damage and will often require extensive work by a qualified technician to restore the video product to its normal operation.
 - E. If the video product has been dropped or the cabinet has been damaged.
 - F. When the video product exhibits a distinct change in performance. This indicates a need for service.
15. **Replacement Parts** - When replacement parts are required, have the service technician verify that the replacements used have the same safety characteristics as the original parts. Use of replacements specified by the video product manufacturer can prevent fire, electric shock or other hazards.
16. **Safety Check** - Upon completion of any service or repairs to this video product, ask the service technician to perform safety checks recommended by the manufacturer to determine that the video product is in safe operating condition.
17. **Wall or Ceiling Mounting** - The cameras provided with this system should be mounted to a wall or ceiling only as instructed in this guide, using the provided mounting brackets.
18. **Heat** - The product should be situated away from heat sources such as radiators, heat registers, stoves, or other products (including amplifiers) that produce heat.

Use

19. **Cleaning** - Unplug the video product from the wall outlet before cleaning. Do not use liquid cleaners or aerosol cleaners. Use a damp cloth for cleaning.
20. **Product and Cart Combination** - Video and cart combination should be moved with care. Quick stops, excessive force, and uneven surfaces may cause the video product and cart combination to overturn.
21. **Object and Liquid Entry** - Never push objects for any kind into this video product through openings as they may touch dangerous voltage points or "short-out" parts that could result in a fire or electric shock. Never spill liquid of any kind on the video product.
22. **Lightning** - For added protection for this video product during a lightning storm, or when it is left unattended and unused for long periods of time, unplug it from the wall outlet and disconnect the antenna or cable system. This will prevent damage to the video product due to lightning and power line surges.



NOTE

This equipment has been certified and found to comply with the limits regulated by FCC, EMC, and LVD. Therefore, it is designated to provide reasonable protection against interference and will not cause interference with other appliance usage.

However, it is imperative that the user follows this manual's guidelines to avoid improper usage which may result in damage to the unit, electrical shock and fire hazard injury.

In order to improve the feature functions and quality of this product, the specifications are subject to change without notice from time to time.

FCC CLASS B NOTICE

Note:

This equipment has been tested and found to comply with the limits for a Class B digital device, pursuant to Part 15 of the FCC Rules. These limits are designed to provide reasonable protection against harmful interference in a residential installation. This equipment generates, uses, and can radiate radio frequency energy and, if not installed and used in accordance with the instruction, may cause harmful interference to radio communications.

However, there is no guarantee that interference will not occur in a particular installation. If this equipment does cause harmful interference to radio or television reception (which can be determined by turning the equipment on and off), the user is encouraged to try to correct the interference by one or more of the following measures:

- Reorient or relocate the receiving antenna
- Increase the separation between the equipment and receiver
- Connect the equipment into an outlet on a circuit different from that to which the receiver is connected
- Consult the dealer or an experienced radio or television technician for assistance

General Precautions

1. All warnings and instructions of this manual should be followed
2. Remove the plug from the outlet before cleaning. Do not use liquid aerosol detergents. Use a water dampened cloth for cleaning
3. Do not use this unit in humid or wet places
4. Keep enough space around the unit for ventilation. Slots and openings in the storage cabinet should not be blocked
5. During lightning storms, or when the unit is not used for a long time, disconnect the power supply, antenna, and cables to protect the unit from electrical surge

DIGIMERGE TECHNOLOGIES INC.

<http://www.digimerge.com>



Table of Contents

Section 1 - Feature List	10
Section 2 - Packing Detail.....	11
Section 3 - Location and Control	
DHU500B Series - Front	14
DHU500B Series - Back	16
Section 4 - Turning On for the First Time	
Starting the DVR - Self Test Screens	20
Starting the DVR - QUAD Display	20
Powering Off the DVR/Stopping Recording.....	20
Main Menu Control	21
Main Menu Tree	22
Display Set	23
Display Set Menu Tree	23
Camera Covert	23
Camera Name	24
OSD ON/OFF Covert	25
Set Display Sequence	25
Event Clear	26
Recording Set	27
Recording Set Menu Tree	27
Global Parameters	29
Normal Recording.....	29
Alarm Recording	30
Motion Recording	31
Schedule Recording	33
Recording ON/OFF	34
System Set	35
Recording Set Menu Tree	35
Basic	36
Disk Format	37
Password Change	37
Client Account	38
Program Update	39
PTZ Menu	39
Network Set	40
DDNS Set	40
IP Set	41
Event Notification.....	42
Email Registration	43
Email Report	43
Notification Out	44



USB - Updating the DVR Firmware	45
Compatible USB Devices	45
Section 5 - Network Connectivity	48
DVR Network Settings	49
Finding Your External IP Address	49
Router Port Forwarding	50
Setting Up Your DDNS Account	51
Setting up DDNS on the DVR.....	53
Section 6 - Troubleshooting	56
Appendix 1 - DVR Specifications.....	60
Appendix 2 - Connecting Motion / Alarm Device	62



The Benchmark for Value in CCTV

SECTION 1

FEATURE LIST

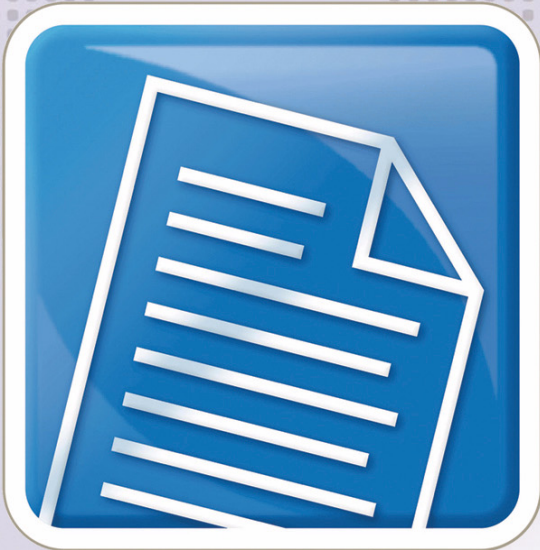

DHU500 Series DVR Features 10

DIGIMERGE™



DHU500 Series DVR Features

Technology

- Embedded LINUX OS
- Total maximum recording rate 120 fps
- High-resolution & high-quality MPEG-4 algorithm
- Uses Watermarking & scrambling technologies
- Strong protection recorded data
- MPEG-4: 1 ~ 2 Kbytes per image with resolution 360x240
- Pentaplex network system: simultaneous local playback, view, record plus network view and playback
- CDRW/DVDRW optical drive and USB port for transferring critical images
- VGA Output
- Integrated video motion detection

Functionality

- Variable recording functions (Normal, Alarm, Motion and Schedule)
- Full channel real-time monitoring
- Live monitoring, recording, playback, backup and remote access at the same time
- Multi channel playback
- Variable event notification to e-mail, buzzer or PC Client system
- Network view & control via browser based application - Several remote DVR's can be controlled by Web browser (PC Client System)
- Supports up to 1 TB internal data storage
- Adjustable video quality settings
- Quick multiple search by date/time, alarm or full list
- Security password protection

Convenience & Stability

- User-friendly UI (Text Based User Interface)
- Easy-to-use menu composition
- Easy-to-use recorded data search (Time, Date, Motion and Alarm)
- Auto restart after power interruption
- DB structure offers data stabilization and best storage utilization



The Benchmark for Value in CCTV

SECTION 2

PACKING DETAIL



Packing Detail 12

DIGIMERGE™



Packing Detail

The DHU500 Series comes with the following components:



DHU500 SERIES DVR



REMOTE CONTROL



POWER CABLE

CHECK YOUR PACKAGE TO CONFIRM THAT YOU HAVE RECEIVED THE COMPLETE SYSTEM, INCLUDING ALL COMPONENTS SHOWN ABOVE.



The Benchmark for Value in CCTV

SECTION 3

LOCATION AND CONTROL



DHU500 Series - Front	14
DHU500 Series - Back.....	16

DIGIMERGE™



DHU500 Series - Front

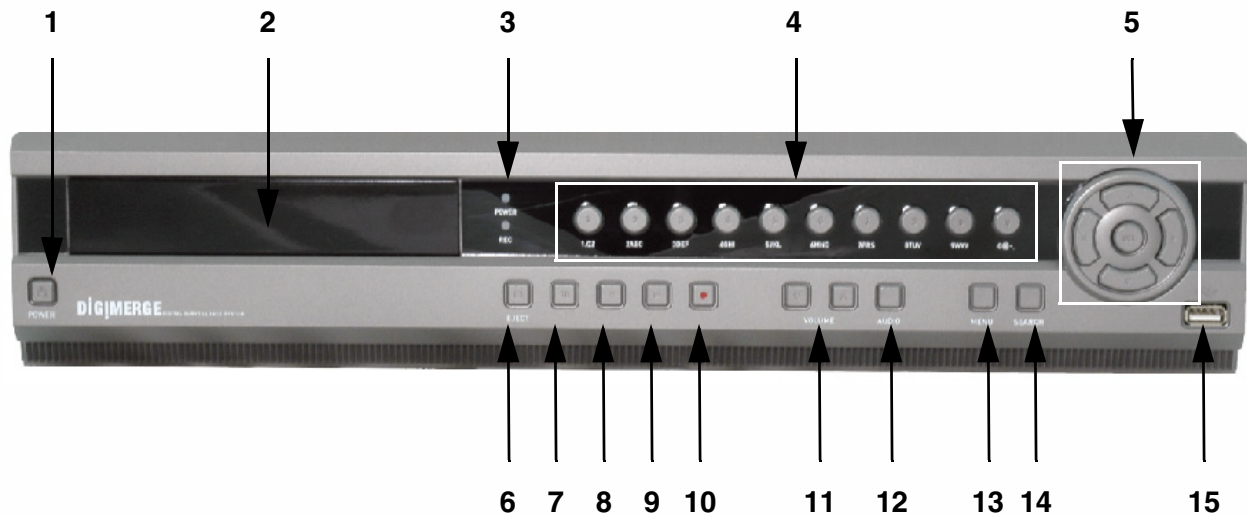

1. **POWER** - Turns the DVR unit ON/OFF.
2. **CDRW DRIVE** - Drive bay for CD-RW Drive
3. **LED POWER AND HDD LIGHTS** - Indicates unit power and HDD activity
4. **NUMBER / LETTER PAD**
 - Use the numbers to switch between cameras in View mode.
 - Use the Numbers and Letters for Menu data input.
5. **SCREEN SELECT / MENU NAVIGATION** - Performs a dual purpose:
 - Changes the Camera view to Single, 4 Camera, 9 Camera or 16 Camera views.
 - Use the $\uparrow\downarrow\leftarrow\rightarrow$ buttons to navigate through the MENU options (in MENU mode).
6. **STOP / EJECT** - Stops the playback of a previously recorded event / Ejects the CDRW Drive.
7. **PAUSE** - Pauses the playback of a previously recorded event.
8. **REV** - REVERSES the playback of a previously recorded event.

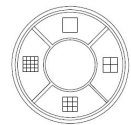

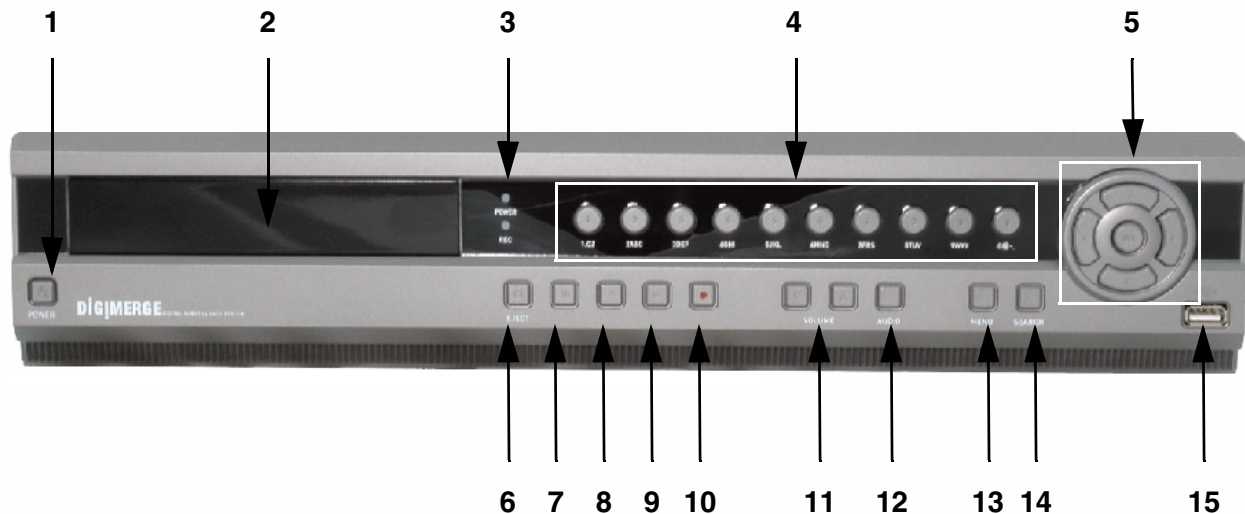

9. **PLAY/FWD** - Starts the playback of a previously recorded event. If the PLAY/FF button is pressed during playback, the FAST FORWARD option will become active.
10. **REC** - Manually starts/stops recording of the currently displayed camera.
11. **VOLUME UP / DOWN** - Raises and Lowers the system volume.
12. **AUDIO** - Switches between cameras 1-4 to receive audio
- * Only one channel audio available on the 4-Channel DVR Model.
13. **MENU** - Accesses the DVR system menu options. See page 21 for details.
14. **SEARCH** - Accesses the Search Menu. See the Operators Manual for Search Menu options
15. **USB PORT** - Connection port for a removable USB Hard Drive (USB Key)



DHU500 Series - Back

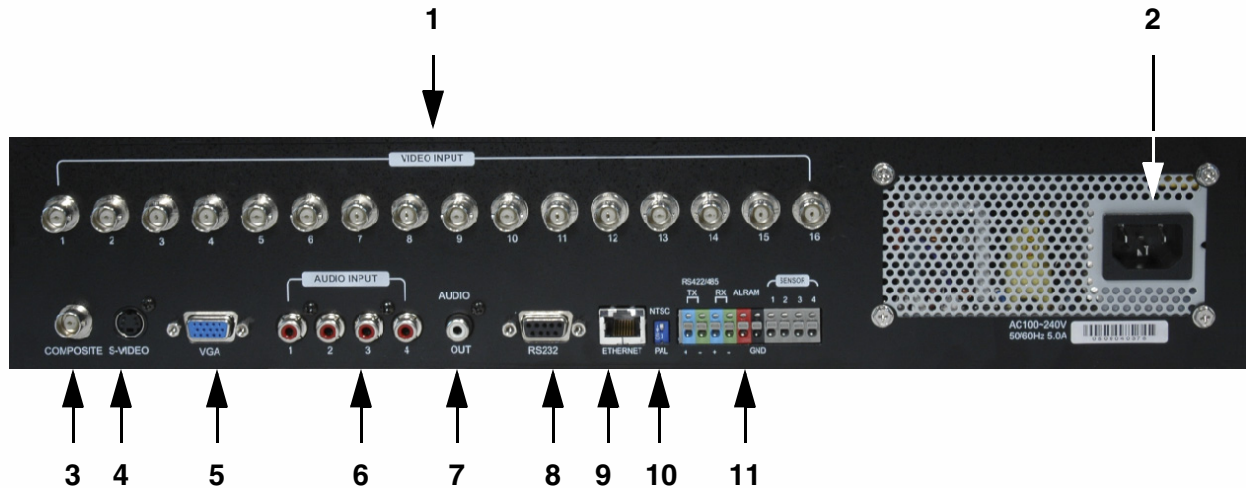

1. **BNC VIDEO INPUTS** - Video inputs for direct connection to Cameras or for looping input to a DVR. The number of ports will vary based on the DVR model (4 Channel, 8 Channel or 16 Channel).
2. **AC INPUT** - Connect the AC power using the power cord provided with the unit from the DVR to an electrical outlet.
3. **COMPOSITE** - A Composite Video OUT connection used to connect the DVR to a Slave Monitor or DVR.
4. **S-VIDEO** - Outgoing connection for S-VIDEO.
5. **VGA PORT** - Used to connect the DVR to a computer Monitor.
6. **AUDIO INPUTS** - Connect up to 4 camera Audio inputs.

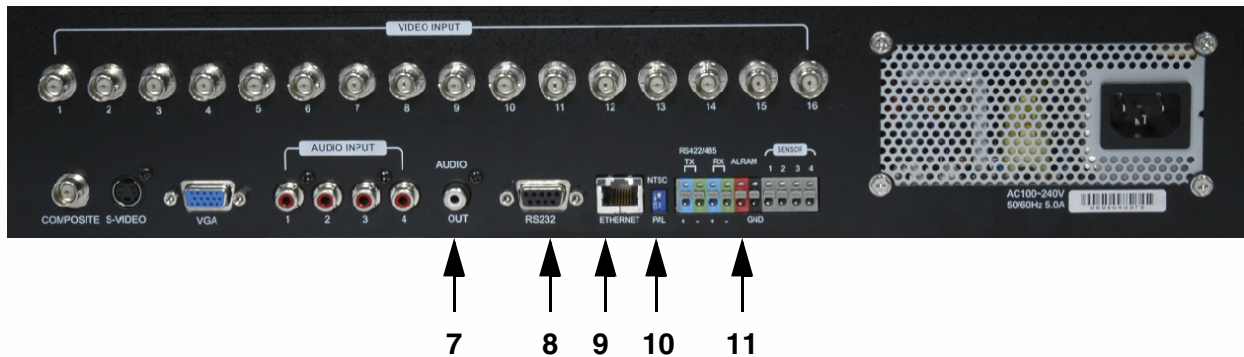

7. **AUDIO OUT** - Connect the Audio OUT to the AUDIO IN on an DVR or Monitor.
8. **RS232 PORT** - Connection for an RS-232 Device.
* Not available on 4-Channel DVR Model.
9. **ETHERNET PORT** - Connects the DVR to a router for connection to the internet. Refer to the Instructions on Page 48 for Remote Connection.
10. **NTSC/PAL SWITCH** - Changes the DVR unit between NTSC and PAL modes.
11. **ALARM / SENSOR BLOCK** - Ports for connecting an Alarm or Sensor Device (such as a Motion Sensor or Window/Door Sensor).



The Benchmark for Value in CCTV

SECTION 4

TURNING ON FOR THE FIRST TIME



Starting the DVR-Self Test Screens....	20
Main Menu Control	21
Main Menu Tree	22
Display Set	23
Recording Set	27
System Set	35
Network Set.....	40
Event Notification	42
USB-Updating the DVR Firmware.....	45

DIGIMERGE™



Starting the DVR - Self Test Screens

Once the DVR has been connected and powered on, the following self-test screens will appear:

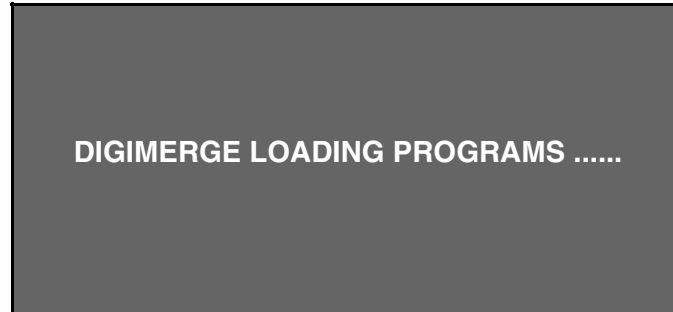

NOTE: If a new **HARD DRIVE** is detected by the system, the DVR will automatically **FORMAT** the new drive.

Starting the DVR - QUAD Display

After the system self-tests have been completed, the DVR will switch to the **CAMERA** viewing screens (in **QUAD MODE**) with the following information displayed on screen:

- **CH1-CH4:** Camera title indicators
- **HDD%:** Percentage of Hard Drive used
- **MM/DD/YYYY - HH:MM:SS:** The current system date and time.



If a camera is not detected, or the Camera is in **COVERT MODE**, the associated portion of the **QUAD** or **MULTI** screen will display a **BLUE SCREEN**.

Powering Off the DVR/Stopping Recording

In order to power down the DVR Unit, or to manually stop the current recording, the default system password of '00000000' will need to be entered (when prompted). If the default password is changed, then the new user specified password will be used instead.



Main Menu Control

- Enter the **MENU** screen by pressing the **MENU** button. The System Password may be required, based on system settings.
- Scroll through the 5 Main options by pressing the **↑↓** buttons.
- To enter a sub-menu, navigate to the option and press the **SEL** button.
- To exit a **SUBMENU**, press the **MENU** button. To save the changes, select the **SAVE & EXIT** option and press the **SEL** button.
- Pressing the **MENU** button from the **MAIN MENU** will exit the **MENU** configuration screen

Outlined below are the buttons used to access menu settings:

- ↑↓←→** : Scroll up and down within a menu option / Change menu options
- SEL** : Press this button to select and change the values in a menu option
- MENU** : Complete modifications of a menu option; exit a menu

NOTE:

After 60 seconds of inactivity in the Menu mode, the system will go back to the previously displayed live camera screen

DISPLAY SET	Set the display options
RECORDING SET	Set the Recording options
SYSTEM SET	Set the System options
NETWORK SET	Set the Network Options
EVENT NOTIFICATION	Setup for Event Notifications through Email

MAIN MENU

DISPLAY SET
RECORDING SET
SYSTEM SET
NETWORK SET
EVENT NOTIFICATION



Main Menu Tree

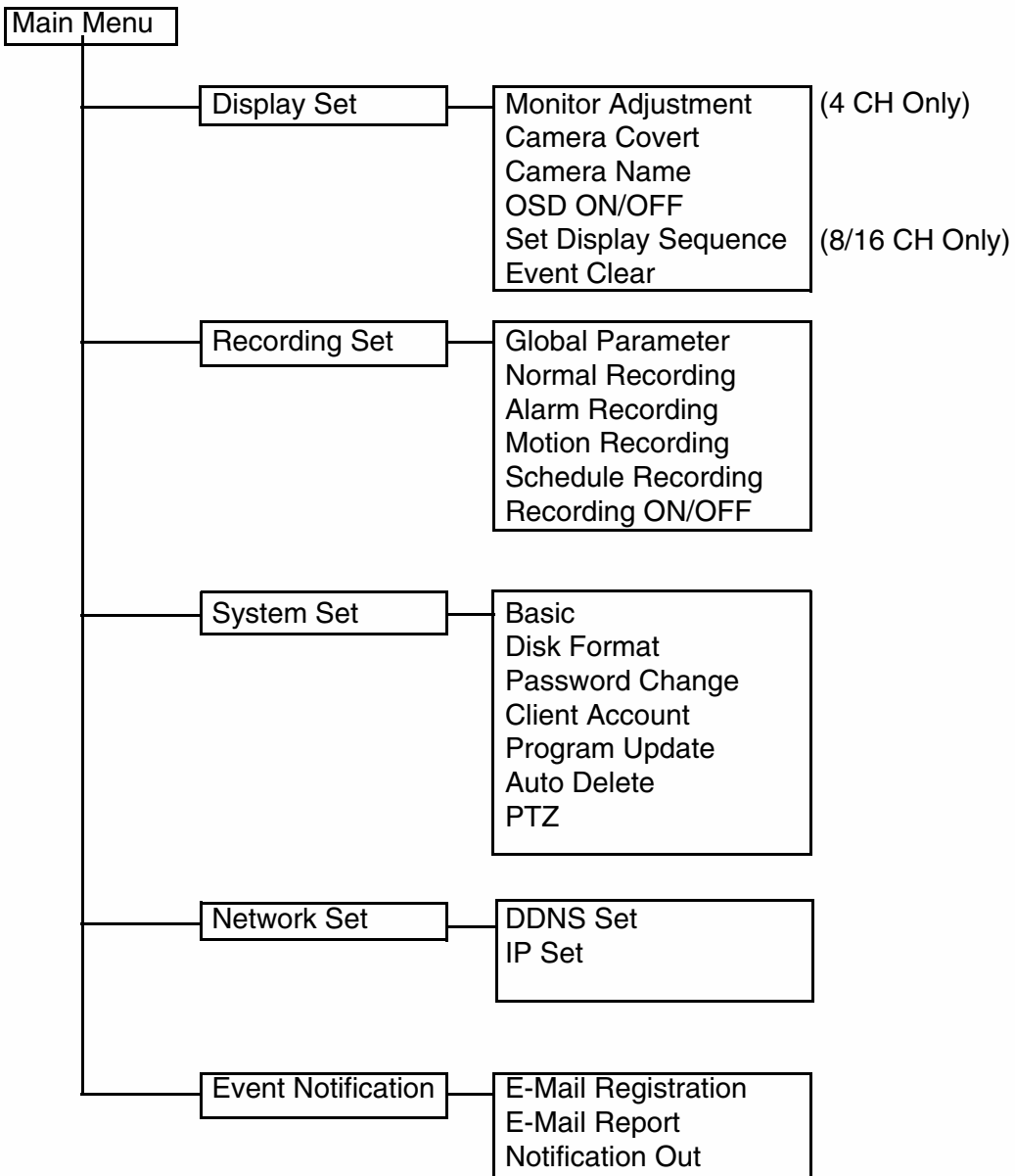



Display Set

This submenu allows you to change the **DISPLAY** options for the DVR unit and any connected cameras. Selecting options on this Menu will access additional settings and options.

Display Set Menu Tree

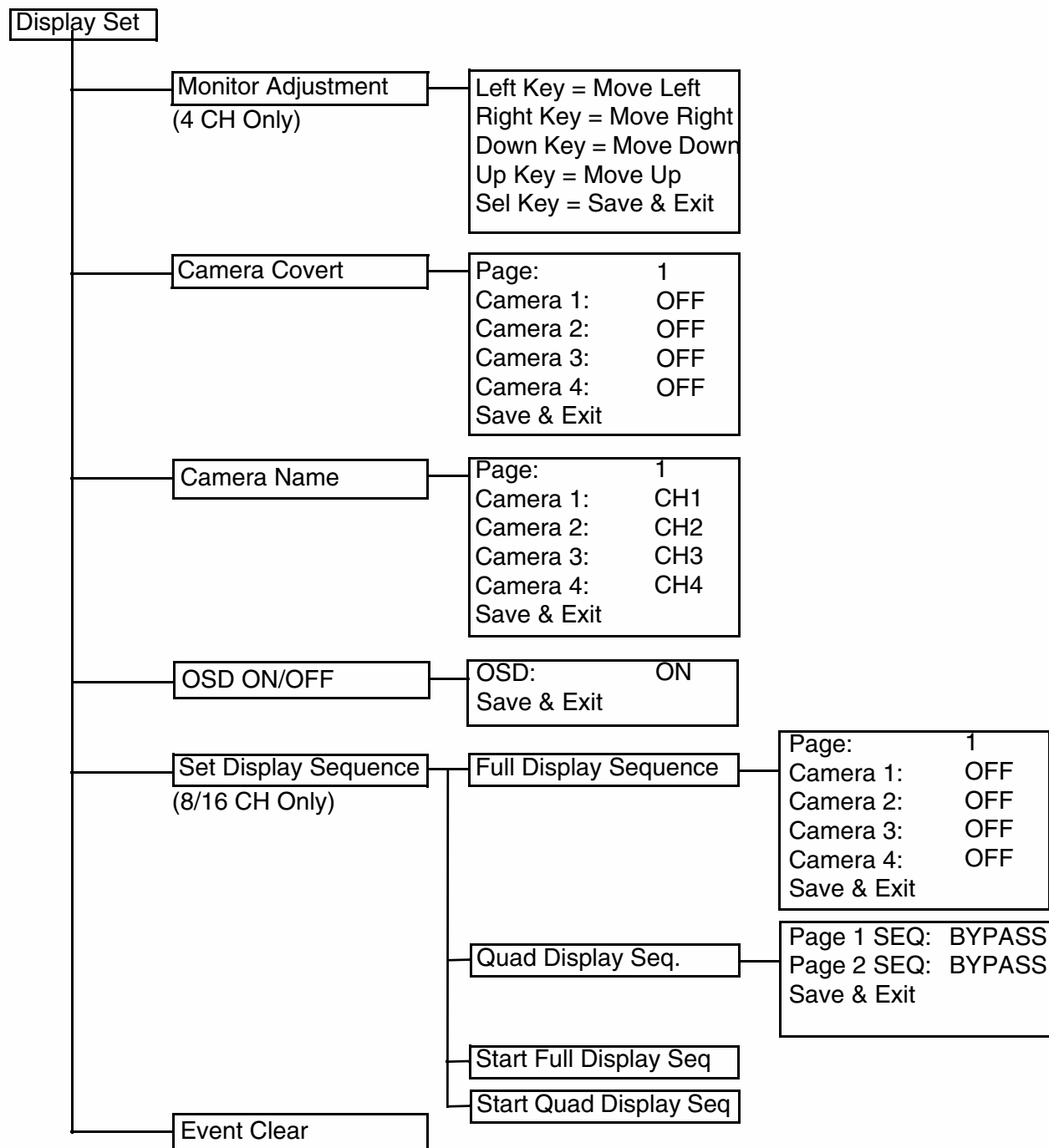



Display Set

Monitor Set (4 CH only)

Allows the attached monitor horizontal and vertical positioning to be adjusted. Use the arrows to adjust the screen left/right and up/down. Press the SEL button to Save and Exit.

Camera Covert

Turns Camera display ON/OFF The DVR unit will continue to record, even if all cameras are set to OFF.

NOTE: The number of cameras displayed will change based on the Model of DVR - 4, 8 or 16 Cameras are available.

Camera Covert	Page:	1
	Camera 1:	OFF
	Camera 2:	OFF
	Camera 3:	OFF
	Camera 4:	OFF
	Save & Exit	

- PAGE:** Displays up to 8 camera configurations per page (second page only available for 16 camera setups). To change the page, press the ↑ and ↓ buttons to highlight, and press the **SEL** button to change to Page 2.
- CAMERA 1 - CAMERA #:** Turn the Camera display ON/OFF. To change the camera setting, press the ↑ and ↓ buttons to highlight, and press the ←→ buttons to change to ON/OFF.
- SAVE & EXIT:** Saves any changes made, and exits to the Main Menu. Press the ↑ and ↓ buttons to highlight, and press the **SEL** button to accept the changes.

Camera Name

Camera names can be set up using this menu.

NOTE: The number of cameras displayed will change based on the Model of DVR - 4, 8 or 16 Cameras are available.

Camera Name	Page:	1
	Camera 1:	CH1
	Camera 2:	CH2
	Camera 3:	CH3
	Camera 4:	CH4
	Save & Exit	

- PAGE:** Displays up to 8 camera configurations per page (second page only available for 16 camera setups). To change the page, press the ↑ and ↓ buttons to highlight, and press the **SEL** button to change to Page 2.
- CAMERA 1 - CAMERA #:** Change the name for the Cameras. To change the camera setting, press the ↑ and ↓ buttons to highlight, and press the **SEL** button to select a camera - a flashing ←symbol will appear. Use the **NUMBER PAD** and ← and → buttons on the front of the DVR to change the name (A-Z, 0-9) to a maximum of 8 characters. Press the **SEL** button to accept the change.
- SAVE & EXIT:** Saves any changes made, and exits to the Main Menu. Press the ↑ and ↓ buttons to highlight, and press the **SEL** button to accept the changes.



OSD ON/OFF

Turns the information display/camera names, hard drive usage, date and time) ON/OFF.

OSD ON/OFF

OSD:	ON
Save & Exit	

- OSD:** Turns the ON SCREEN DISPLAY to ON/OFF. To change the setting, press the ↑ and ↓ buttons to highlight, and press the ←→ buttons to switch between ON/OFF.
- SAVE & EXIT:** Saves any changes made, and exits to the Main Menu. Press the ↑ and ↓ buttons to highlight, and press the **SEL** button to accept the changes.

Set Display Sequence (8/16 CH Only)

Display Settings for Single or Quad display of the cameras (in Sequence Mode).

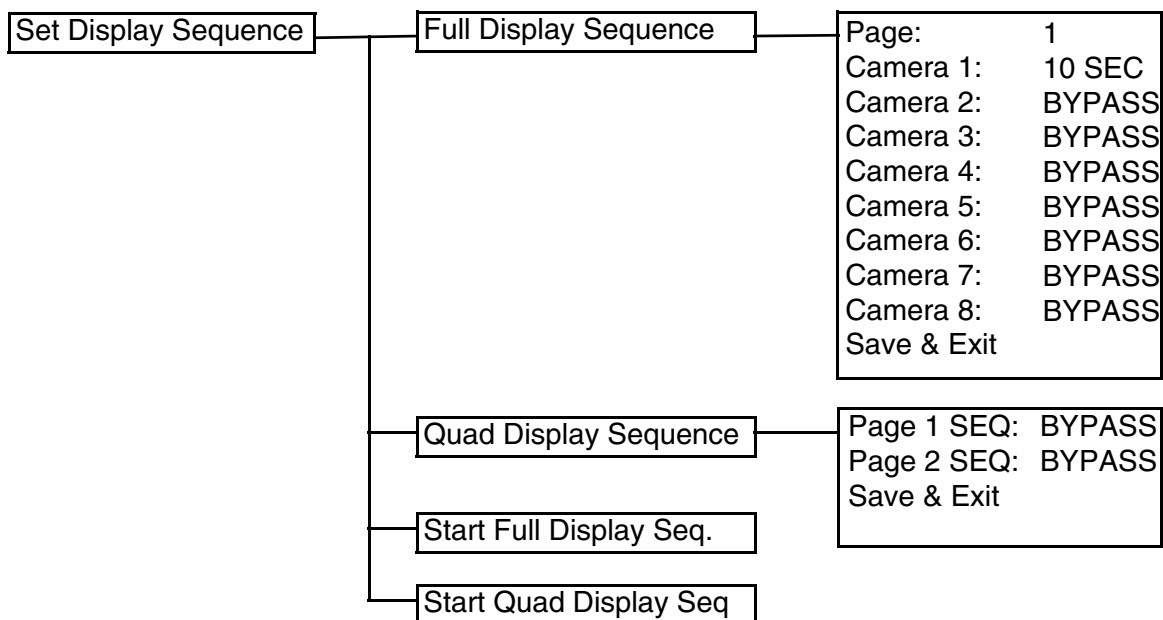

NOTE: The number of cameras displayed on submenus will change based on the Model of DVR: 4, 8 or 16 Cameras are available.



Set Display Sequence

- FULL DISPLAY SEQUENCE:** Set the length of time each camera is displayed in cycling Full Screen Display mode:
 - **PAGE:** Displays up to 8 camera configurations per page (second page only available for 16 camera setups). To change the page, press the ↑ and ↓ buttons to highlight, and press the **SEL** button to change to Page 2.
 - **CAMERA 1 - CAMERA #:** Set the length of time that a Camera is displayed in Sequence Mode. To change the camera setting, press the ↑ and ↓ buttons to highlight, and use the ← and → buttons on the front of the DVR to change the length of time a Camera is displayed. Options include 5, 10, 15, 30, 45, 60 (in seconds) and Bypass.
 - **SAVE & EXIT:** Saves any changes made, and exits to the Main Menu. Press the ↑ and ↓ buttons to highlight, and press the **SEL** button to accept the changes.
- QUAD DISPLAY SEQUENCE:** Set the length of time each QUAD of cameras (4 cameras per page) is displayed in cycling QUAD Display mode:
 - **PAGE # SEQ:** Set the length of time that a QUAD of Cameras is displayed in Sequence. To change the Page setting, press the ↑ and ↓ buttons to highlight. Page 1 (Cameras 1-4), Page 2 (Cameras 5-8) etc. Use the ← and → buttons on the front of the DVR to change the length of time a Quad is displayed. Options include 5, 10, 15, 30, 45, 60 (in seconds) and Bypass.
 - **SAVE & EXIT:** Saves any changes made, and exits to the Main Menu. Press the ↑ and ↓ buttons to highlight, and press the **SEL** button to accept the changes.
- START FULL DISPLAY SEQUENCE:** Starts viewing Cameras in Full Screen Display Sequence Mode (based on the settings configured in the **FULL DISPLAY SEQUENCE** menu).
- START QUAD DISPLAY SEQUENCE:** Starts viewing Cameras in QUAD Display Sequence Mode (based on the settings configured in the **QUAD DISPLAY SEQUENCE** menu).

Event Clear

Clears the OSD characters related with events from the monitor display.



Recording Set

This submenu allows you to change the **RECORDING** options for the DVR unit. Selecting options on this Menu will access additional settings and options.

Recording Set Menu Tree

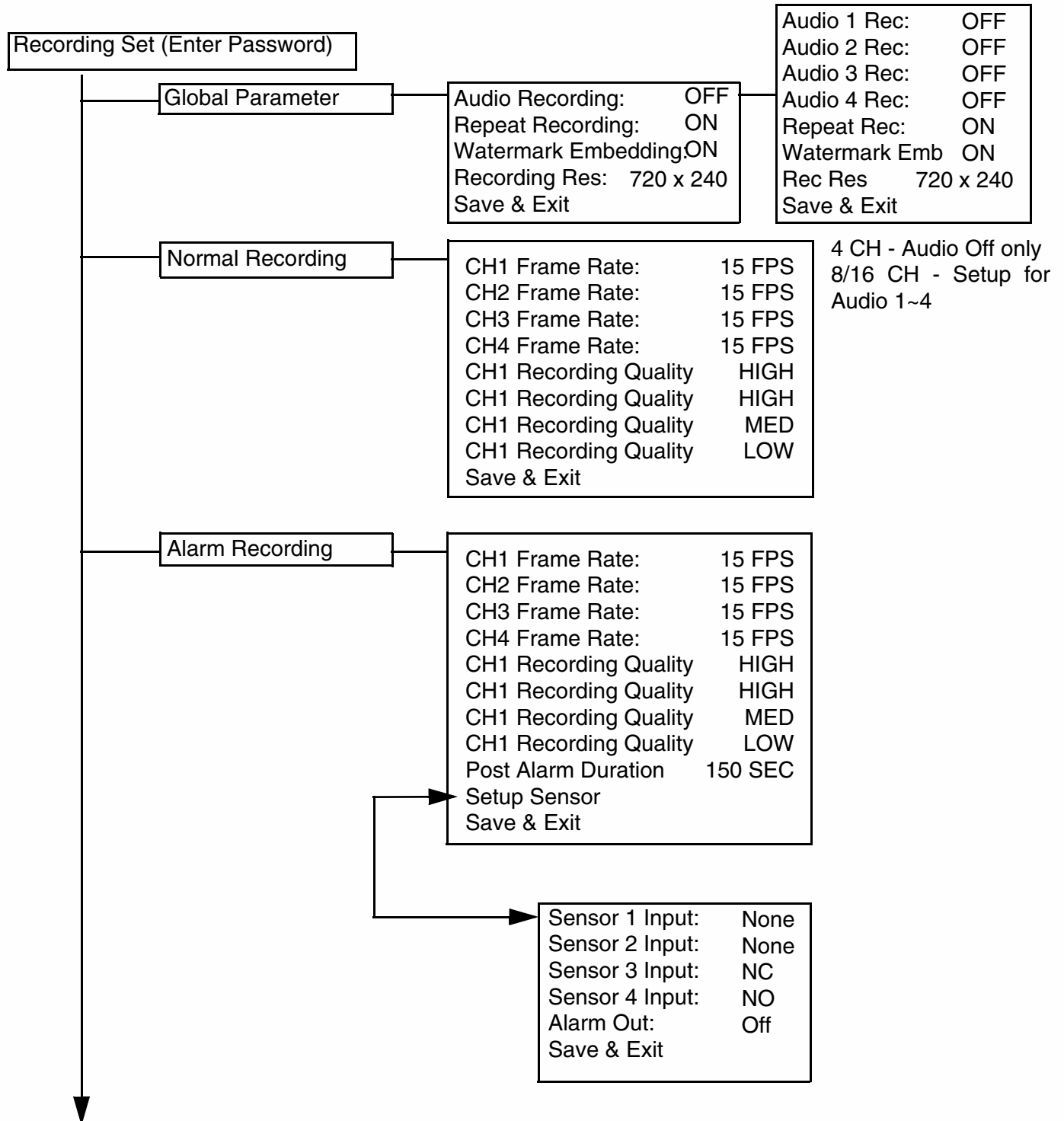

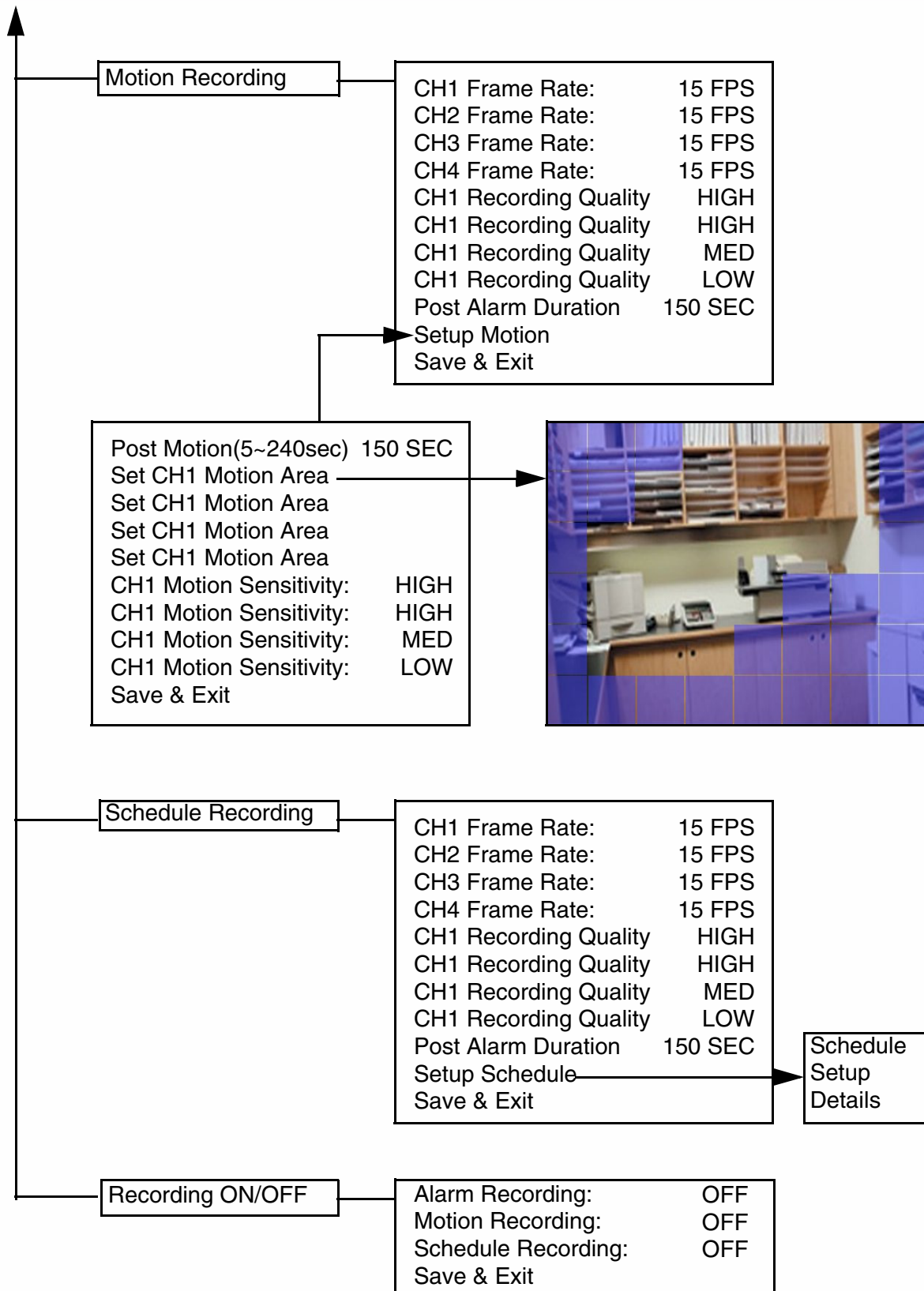



Recording Set

Global Parameters

Settings for General Parameters.

The 4Ch Model only has the option of ON/OFF (one channel audio only), and does not show this extended menu.

Global Parameter

Audio 1 Rec:	OFF
Audio 2 Rec:	OFF
Audio 3 Rec:	OFF
Audio 4 Rec:	OFF
Repeat Rec:	ON
Watermark Emb	ON
Rec Res	720 x 240
Save & Exit	

1. **AUDIO # REC:** Turns Audio recording ON/OFF. press the ↑ and ↓ buttons to highlight, and press the ←→ buttons to change to ON/OFF. 4CH model does not have extended menu as above.
2. **REPEAT RECORDING:** Allows the DVR unit to repeat recording. To change the setting, press the ↑ and ↓ buttons to highlight, and press the ←→ buttons to change to ON/OFF.
3. **WATERMARK EMBEDDING:** Adds Watermarking to the recorded event. Press the ↑ and ↓ buttons to highlight, and press the ←→ buttons to change to ON/OFF.
4. **RECORDING RESOLUTION:** Sets the Recording Resolution for events. To change the Resolution, press the ↑ and ↓ buttons to highlight, and press the ←→ buttons to change to either 720x240 or 360x240.
5. **SAVE & EXIT:** Saves any changes made, and exits to the Main Menu. Press the ↑ and ↓ buttons to highlight, and press the **SEL** button to accept the changes.

Normal Recording

Controls the settings for Manual Recording.

Normal Recording

CH1 Frame Rate:	15 FPS
CH2 Frame Rate:	15 FPS
CH3 Frame Rate:	15 FPS
CH4 Frame Rate:	15 FPS
CH1 Recording Quality	HIGH
CH1 Recording Quality	HIGH
CH1 Recording Quality	MED
CH1 Recording Quality	LOW
Save & Exit	

1. **CH1~4 FRAMERATE:** Set the number of Frames Per Second. Press the ↑ and ↓ buttons to highlight, and press the ←→ buttons to set the FPS between 0~15 Seconds.
2. **QUALITY:** Set the quality level for the recording to High, Mid or Low
3. **SAVE & EXIT:** Saves any changes made, and exits to the Main Menu. Press the ↑ and ↓ buttons to highlight, and press the **SEL** button to accept the changes.



Motion Recording

Setup and configurations for Motion Sensor events.

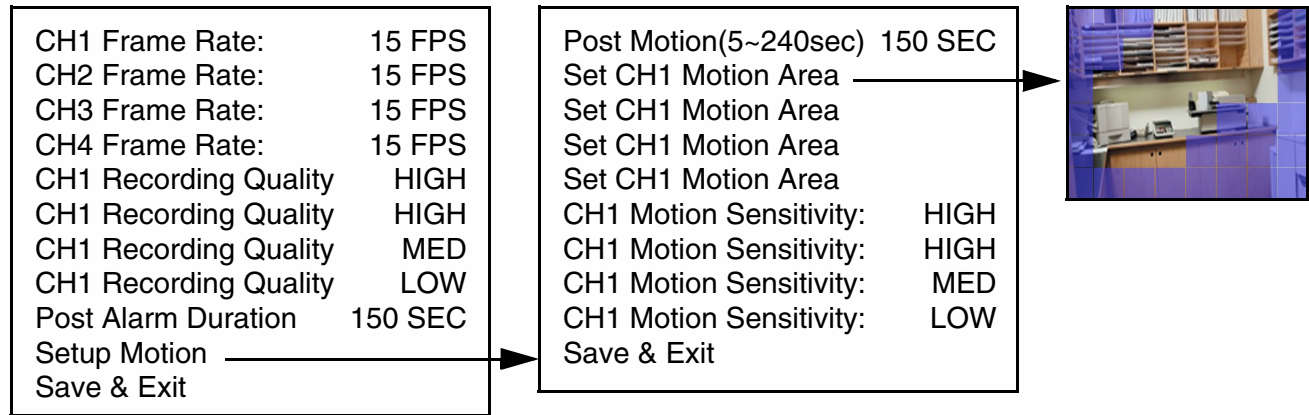

- CH1-CH4 FRAMERATE:** Set the number of Frames Per Second. Press the ↑ and ↓ buttons to highlight, and press the **SEL** button to select, and use the ← and → and **SEL** buttons to change the settings.
- QUALITY** - Set the quality level for the recording to High, Mid or Low
- POST MOTION DURATION:** Set the duration that the DVR will record once motion is detected: 5, 30, 60, 90, 120, 150, 180, 210 or 240 seconds.
- SETUP MOTION:** Configuration for each Motion Sensor enabled Camera Press the ↑ and ↓ buttons to highlight the Setup Motion option, and press the **SEL** button to access the SETUP MOTION submenu. Press the ↑ and ↓ buttons to highlight a specific Camera, and press the **SEL** button to select.
 - POST MOTION:** Set the length of time to continue recording after motion has stopped.
 - AREA:** Press the **SEL** button on the **AREA** option to specify segments of the Camera view to have Motion Detection. Use the ↑↓←→ buttons to navigate around the Motion Setup screen, and press the **SEL** button to turn a segment ON/OFF. Press the **MENU** button once complete. Dark Blue indicates that a section has been selected for motion detection, and blank areas indicate that motion will not be detected in those areas.
 - SENSE:** Sets the Sensitivity of the Motion Detection: Use the ← and → and **SEL** buttons to change the setting to High, Mid, Low or Off.
- SAVE & EXIT:** Saves any changes made, and exits to the Main Menu. Press the ↑ and ↓ buttons to highlight, and press the **SEL** button to accept the changes.



Schedule Recording

Setup and configurations for Scheduled events.

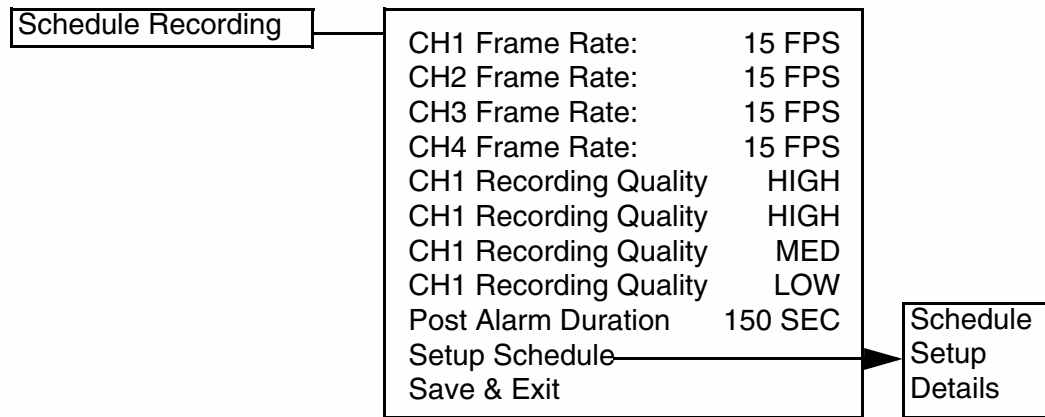

1. **CH1-CH4 FRAMERATE:** Set the number of Frames Per Second. Press the ↑ and ↓ buttons to highlight, and press the **SEL** button to select, and use the ← and → and **SEL** buttons to change the settings.
2. **QUALITY** - Set the quality level for the recording to High, Mid or Low
3. **POST ALARM DURATION** - Set the length of time to continue recording after the alarm has stopped.
4. **SETUP SCHEDULE:** Settings for scheduled recording times. Press the ↑ and ↓ buttons to highlight, and press the **SEL** button to access the Schedule Setup Submenu:
 - Use the ↑ and ↓ to choose a day (SUN-SAT) and **SEL** to set the schedule.
 - Use the ↑↓←→ buttons to set the recording Start Time and End Time
 - Select SAVE & EXIT to return to the Menu

	FROM	TO	FROM	TO
SUN	00:00	00:00	00:00	00:00
MON	00:00	00:00	00:00	00:00
TUE	00:00	00:00	00:00	00:00
WED	00:00	00:00	00:00	00:00
THU	00:00	00:00	00:00	00:00
FRI	00:00	00:00	00:00	00:00
SAT	00:00	00:00	00:00	00:00
Save & Exit				

5. **SAVE & EXIT:** Saves any changes made, and exits to the Main Menu. Press the ↑ and ↓ buttons to highlight, and press the **SEL** button to accept the changes.



Recording ON/OFF

Controls the Recording for Event Types.

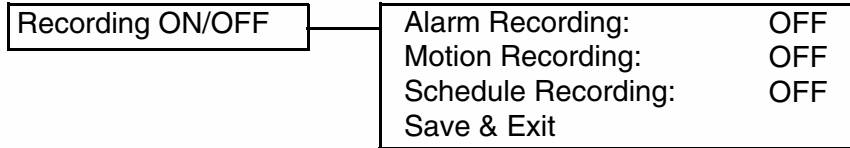

ALARM RECORDING: Turns Alarm Recording ON/OFF. Press the ↑ and ↓ buttons to highlight, and press the ←→ buttons to switch between ON and OFF.

MOTION RECORDING: Turns Motion Recording ON/OFF. Press the ↑ and ↓ buttons to highlight, and press the ←→ buttons to switch between ON and OFF.

SCHEDULE RECORDING: Turns Schedule Recording ON/OFF. Press the ↑ and ↓ buttons to highlight, and press the ←→ buttons to switch between ON and OFF.

SAVE & EXIT: Saves any changes made, and exits to the Main Menu. Press the ↑ and ↓ buttons to highlight, and press the **SEL** button to accept the changes.



System Set

This submenu allows you to change the **SYSTEM** options for the DVR unit. Selecting options on this Menu will access additional settings and options.

Recording Set Menu Tree

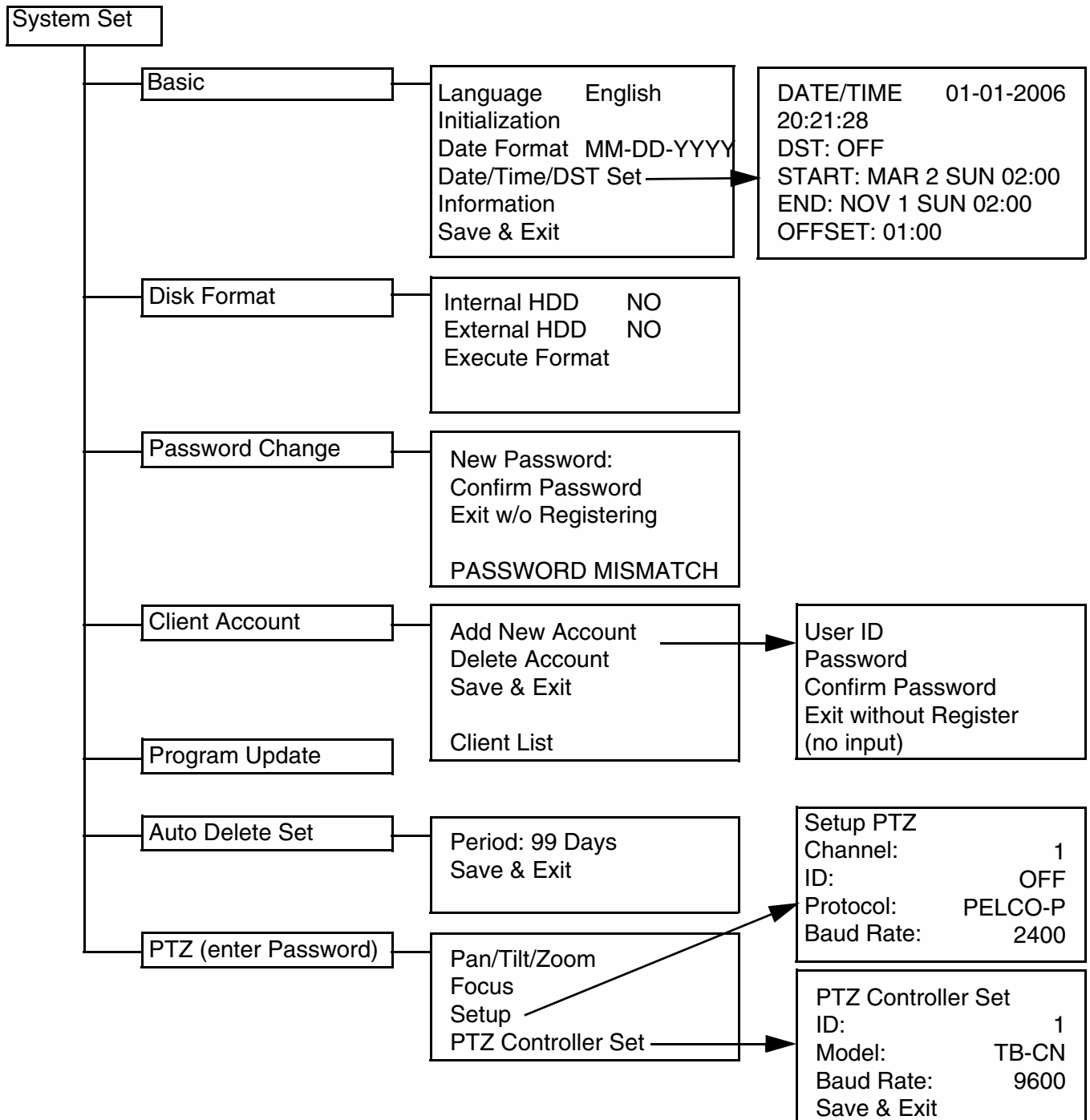



System Set

Basic

Settings for General Parameters.

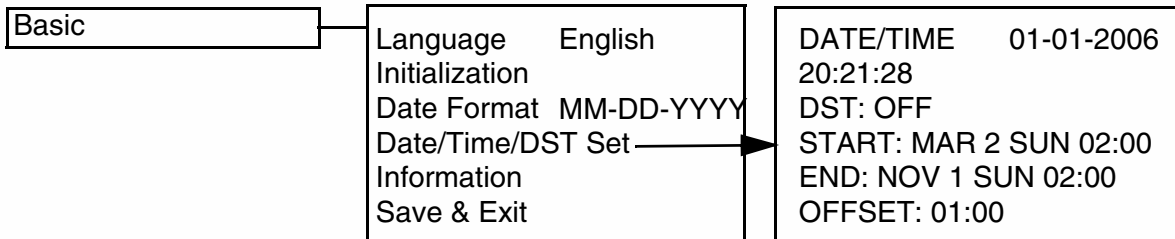

- LANGUAGE:** Displays the current default language on the DVR (English or Dutch).
- INITIALIZATION:** Resets all settings to Factory Default. To change the setting, press the **↑** and **↓** buttons to highlight, and press the **SEL** button. A message will appear prompting for User input:
All setup will be returned to Factory Default
 - Press the Select key to continue
 - Press the Menu key to exit
- DATE FORMAT:** Configuration for the date display on the DVR. Press the **↑** and **↓** buttons to highlight, and press the **←→** to change the date format:
 - MM-DD-YYYY
 - DD-MM-YYYY
 - YYYY-MM-DD
- DATE/TIME/DST SET:** Sets the Date and Time for the unit. Press the **↑** and **↓** buttons to highlight, and press the **SEL** key to enter the configuration. Press the **↑↓←→** buttons to change the date format. Daylight Savings can be set from this menu to run between set days.
- INFORMATION:** Displays System Information:

HDD Capacity:	## GB / ## GB
FPGA Version:	#####
Application:	#####
RAMDisk Version:	#####
Kernel Version:	#####
IP Address:	###.###.###.###
MAC Address	##:##:##:##:##:##

- SAVE & EXIT:** Saves any changes made, and exits to the Main Menu. Press the **↑** and **↓** buttons to highlight, and press the **SEL** button to accept the changes.



Disk Format

Displays Hard Drive information.

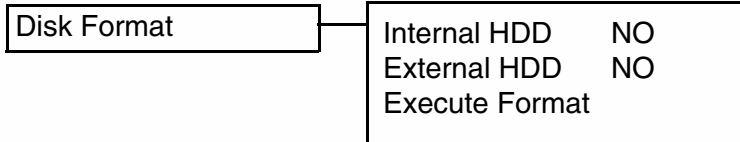

1. **INTERNAL HDD:** Allows the user to format the HDD. Use the ←→ to change this option to YES or NO. To format the Drive, set this option to YES and select the EXECUTE FORMAT option.
2. **EXTERNAL HDD:** Allows the user to format the External HDD. Use the ←→ to change this option to YES or NO. To format the Drive, set this option to YES and select the EXECUTE FORMAT option.
3. **EXECUTE FORMAT:** Allows the Hard Drive to be formatted. Press the ↑ and ↓ buttons to highlight, and press the **SEL** button to format. Enter the SYSTEM PASSWORD to start the Format process.

Password Change

Allows the user to change the default password. The existing password must be entered to access this screen.

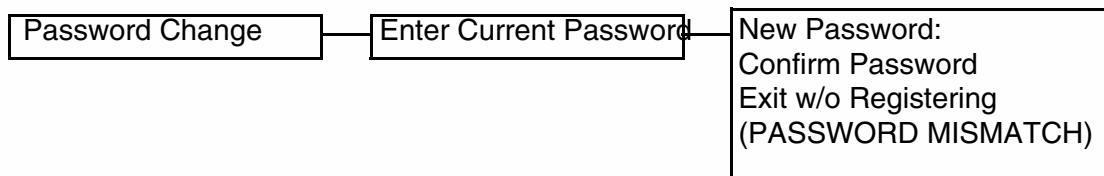

1. **NEW PASSWORD:** Enter a new system password. Press the ↑ and ↓ buttons to highlight, and press the **SEL** button to set a new password. Use the NUMBER keys (0-9) on the front panel of the DVR to set the password of up to 8 characters.
2. **CONFIRM PASSWORD:** Enter the same password as set above. Press the ↑ and ↓ buttons to highlight, and press the **SEL** button to set a new password. Use the NUMBER keys (0-9) on the front panel of the DVR.
3. **EXIT WITHOUT REGISTERING:** Exits from the Password menu without changing the password.

NOTE: If the Password is not entered correctly on both the NEW and CONFIRM password sections, the message **PASSWORD MISMATCH** will appear at the bottom of the screen.



Client Account

Configuration for additional user accounts.

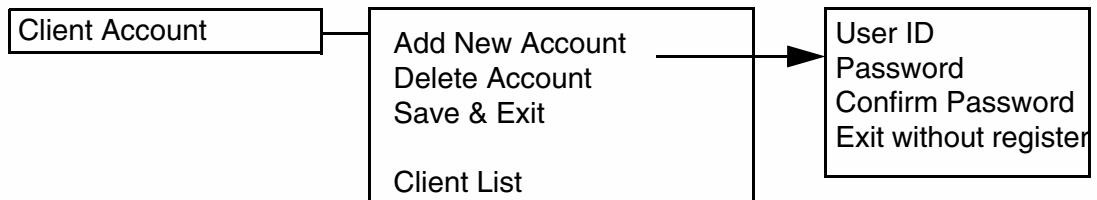

- 1. ADD NEW ACCOUNT:** Add a new user account to the system. Press the ↑ and ↓ buttons to highlight, and press the **SEL** button to access the User Setup screen:
 - **USER ID:** Enter the user ID. Press the ↑↓←→ and Numbers (0-9) and Letters (A-Z, @ - _) on the front panel of the DVR to enter information.
 - **PASSWORD:** Enter a password. Press the ↑ and ↓ buttons to highlight, and press the **SEL** button to set a new password. Use the NUMBER keys (0-9) on the front panel of the DVR to set the password of up to 8 characters.
 - **CONFIRM PASSWORD:** Enter the same password as set above. Press the ↑ and ↓ buttons to highlight, and press the **SEL** button to set a new password. Use the NUMBER keys (0-9) on the front panel of the DVR.
 - **EXIT:** Exits without setting up an account.
- 2. DELETE ACCOUNT:** Displays a list of accounts. Press the ↑ and ↓ buttons to highlight, and press the **SEL** button to access the User list. Select a user and press the **SEL** key to delete the account.
- 3. SAVE & EXIT:** Saves any changes made, and exits to the Main Menu. Press the ↑ and ↓ buttons to highlight, and press the **SEL** button to accept the changes.

Program Update

Allows the user to update the DVR firmware by downloading the most current application from the Digimerge website, and using a Memory Stick. Download the most current program from the <http://www.digimerge.com> website, and copy it to a Memory Stick. Connect the Memory Stick to the USB 2.0 Port on the front panel of the DVR.

1. Enter the Menu - System Set and choose Program Update:
 - **NEW PROGRAM FOUND:** If the new application is recognized, the DVR unit will display a processing percentage. Reboot the DVR once complete.
 - **NEW PROGRAM NOT FOUND:** If the application is not recognized, processing will not continue.

Auto Delete Set

Sets the length of time that data will be held in the hard drive before it is deleted. Press the ↑ and ↓ buttons to highlight the AUTO DELETE SET option, and press the **SEL** button to access the day setting. Use the Number pad to set the option between 0 days to 99 days or None. Choose the Save & Exit option to accept the changes to this option. The default setting is None.



PTZ Menu

Pan / Tilt / Zoom control (for Pelco D or Pelco P Model Cameras only)

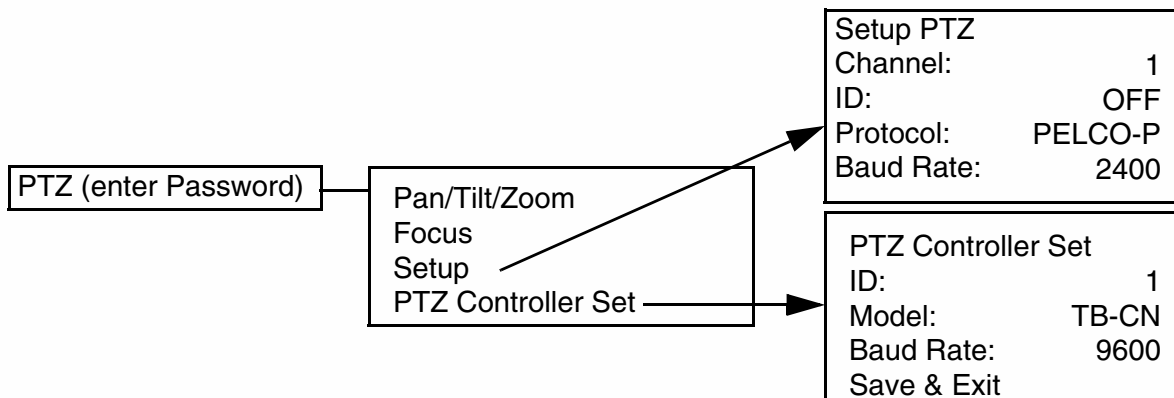

1. **PAN / TILT / ZOOM:** Accesses the PTZ Control for a camera. Press the ↑ and ↓ buttons to highlight, and press the **SEL** button to access PTZ controls:

- LEFT/RIGHT - Pans the camera LEFT/RIGHT
- UP/DOWN - Tilts the camera UP/DOWN
- VOL UP/DOWN - Zooms the camera IN/OUT
- SEL/MENU - Stops viewing / Exits viewing

2. **FOCUS:** Accesses the Focus Control for a camera. Press the ↑ and ↓ buttons to highlight, and press the **SEL** button to access FOCUS controls:

- UP/DOWN - Focuses NEAR/FAR
- SEL/MENU - Stops/Exits Menu



3. **SETUP:** Setup of the PTZ Cameras. Press the ↑ and ↓ buttons to highlight, and press the **SEL** button to enter the SETUP menu:

- **CHANNEL:** Select the PTZ camera location (Channel 1-4, 1-8, or 1-16 depending on model)
- **ID:** Set the camera ID (1-256, or OFF).
- **Protocol:** Select the PTZ Protocol (PELCO-D or PELCO-P)
- **Baud Rate:** Select the Baud Rate for the Camera (2400, 4800 or 9600 BPS)
- **SAVE & EXIT:** Saves any changes, and exits to the previous menu.

```

Setup PTZ
Channel:          1
ID:              OFF
Protocol:        PELCO-P
Baud Rate:       9600
  
```



4. **PTZ CONTROLLER:** Setup of the PTZ Controller. Press ↑ and ↓ buttons to highlight, and press **SEL** button to enter the PTZ Controller menu.

- **ID:** Set the PTZ Controller ID (001 - 999).
- **Model:** TB-CN Series - This cannot be changed.
- **BAUD RATE:** Set the baud rate of the PTZ Controller (9600 BPS)
- **SAVE & EXIT:** saves any changes, and exits to the previous menu.

PTZ Controller Set	
ID:	1
Model:	TB-CN
Baud Rate:	2400
Save & Exit	

Network Set

This submenu allows you to change the **NETWORK** options for the DVR unit. The options in the DDNS Set menu control access to the DVR using the free DDNS server, and the options in the IP Set section control local network settings for local access to the DVR.

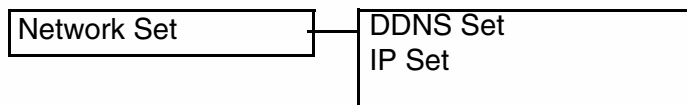

DDNS Set

The options in the DDNS Set menu allow the DVR unit to be accessed remotely using the Free DDNS Server and the internet. All information will need to be manually entered based on information from the free DDNS Setup (see page 35 for details). Set the USE DYNAMIC IP option to YES if you will be using the Free DNS Website service to connect to your DVR.

- **DDNS:** Press the ↑ and ↓ buttons to highlight, and press the **SEL** button to set to NO/YES.
- **DOMAIN NAME:** Press the ↑ and ↓ buttons to highlight, and press the **SEL** button to set to enter setup. Use the Numbers and Letters on the front panel of the DVR to set the Domain Name (i.e. To enter the Domain Name DHU504.digimerge.net, just enter DHU504)

DDNS:	YES
Domain Name:	#####
User Name:	#####
Password:	#####
DDNS Status Check	
Save & Exit	

- **USER NAME:** Press the ↑ and ↓ buttons to highlight, and press the **SEL** button to set to enter setup. Use the Numbers and Letters on the front panel of the DVR to set the Domain Name.
- **PASSWORD:** Press the ↑ and ↓ buttons to highlight, and press the **SEL** button to set to enter setup. Use the Numbers and Letters on the front panel of the DVR to set the Domain Name.
- **DNS STATUS CHECK:** Connects to the remote DNS Server to check the Status. Press the ↑ and ↓ buttons to highlight, and press the **SEL** button to test the connection:
 - Checking DDNS NOW. Please wait... it may take a few minutes
 - A Status message will appear indicating a PASS or FAIL on the connection:
 - DDNS Status Check: PASS / FAIL
- **SAVE & EXIT:** Saves any changes made, and exits to the Main Menu. Press the ↑ and ↓ buttons to highlight, and press the **SEL** button to accept the changes.



IP Set

The options in the IP Set menu control the local network setup for the Unit. See 45 for additional network setup instructions.

- **DHCP:** Press the ↑ and ↓ buttons to highlight, and press the ←→ buttons to set to NO/YES. Set this option to YES to allow the unit to get Network information from the Router; set this option to NO if information will be manually assigned to the DVR unit.
- **IP ADDRESS:** Press the ↑ and ↓ buttons to highlight, and press the **SEL** button to enter setup. Use the Numbers on the front panel of the DVR to set the IP address.
- **GATEWAY:** Press the ↑ and ↓ buttons to highlight, and press the **SEL** button to set to enter setup. Use the Numbers on the front panel of the DVR to set the Gateway address.
- **NETMASK:** Press the ↑ and ↓ buttons to highlight, and press the **SEL** button to set to enter setup. Use the Numbers on the front panel of the DVR to set the Net Mask.
- **DNS SERVER:** Press the ↑ and ↓ buttons to highlight, and press the **SEL** button to enter setup. Use the Numbers on the front panel of the DVR to set the DNS Server address.
- **DVR PORT:** Press the ↑ and ↓ buttons to highlight, and press the **SEL** button to enter setup. Use the Numbers on the front panel of the DVR to set the DVR Port to **2000**.
- **WEBSERVER PORT:** Press the ↑ and ↓ buttons to highlight, and press the **SEL** button to enter setup. Use the Numbers on the front panel of the DVR to set the Webserver Port to **0080**.
- **SAVE & EXIT:** Saves any changes made, and exits to the Main Menu. Press the ↑ and ↓ buttons to highlight, and press the **SEL** button to accept the changes.

DHCP:	NO
IP Address:	###.###.###.###
Gateway:	###.###.###.###
Netmask:	###.###.###.###
DNS Server:	###.###.###.###
DVR Port:	2000
Webserver Port:	0080
Save & Exit	



Event Notification

This submenu allows you to change the **NETWORK** options for the DVR unit. The options will change based on the DYNAMIC IP being set to NO or YES.

Event Notification Menu Tree

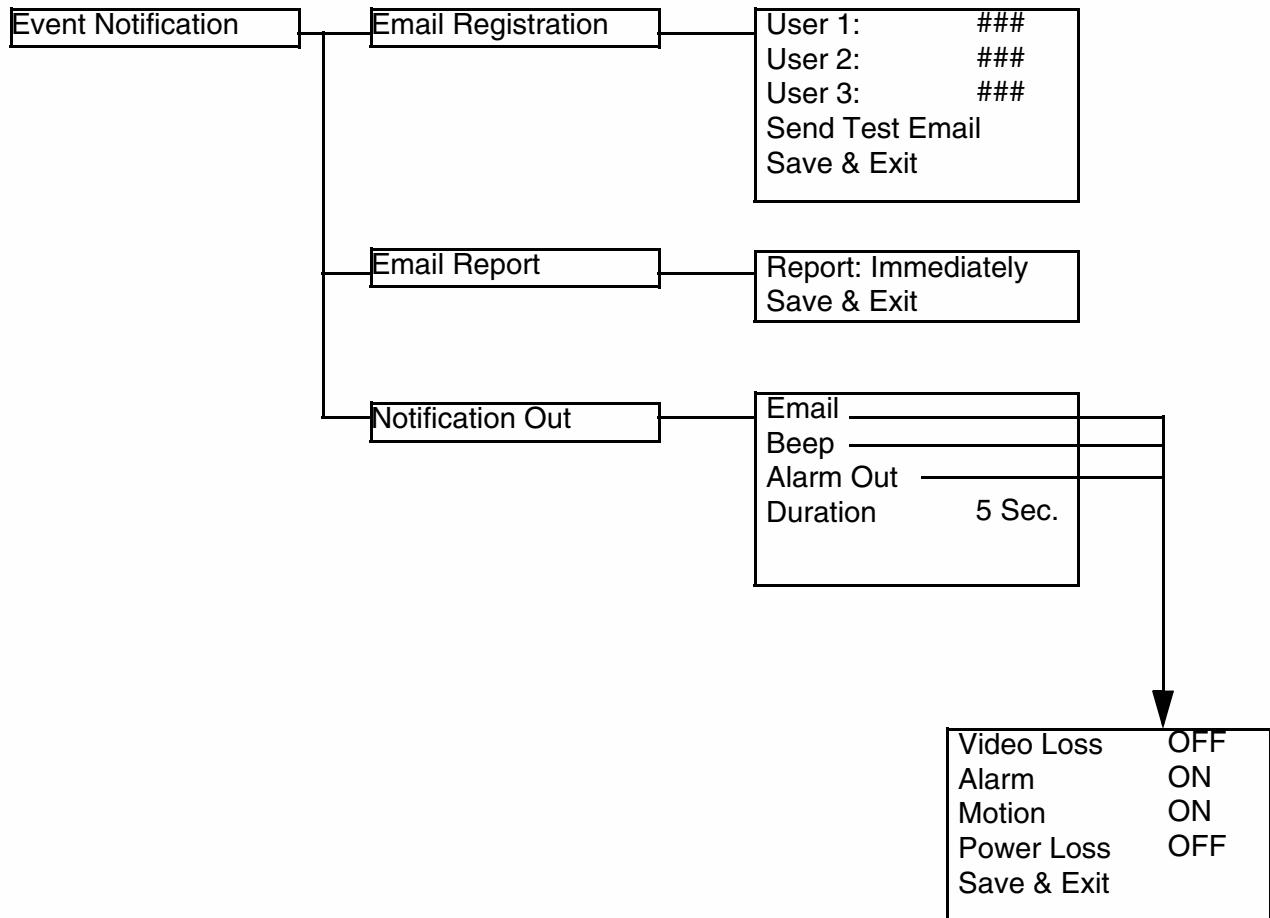



Event Notification

Email Registration

Configuration settings for automatic emailing of events.

Email Registration	User 1:	###
	User 2:	###
	User 3:	###
	Send Test Email	###
	Save & Exit	###

1. **USER 1 - USER 3:** Setup of up to 3 email accounts to receive event emails. Press the ↑ and ↓ buttons to highlight, and press the **SEL** key to enter the configuration. Press the ↑↓←→ buttons and Letters (A-Z), Numbers(0-9) and Symbols (@ - _) located on the front of the DVR to enter the Email address.
2. **SEND TEST EMAIL:** Sends a test email to all configured Email addresses. To send a test email, press the ↑ and ↓ buttons to highlight, and press the **SEL** button.
3. **SAVE & EXIT:** Saves any changes made, and exits to the Main Menu. Press the ↑ and ↓ buttons to highlight, and press the **SEL** button to accept the changes.

Email Report

Configuration settings for automatic emailing of events.

Email Report	Report: Immediately
	Save & Exit

1. **REPORT:** Specify when an email alert should be sent. Press the ↑ and ↓ buttons to highlight, and press the ←→ buttons to set to Immediately, Daily or Weekly.
2. **SAVE & EXIT:** Saves any changes made, and exits to the Main Menu. Press the ↑ and ↓ buttons to highlight, and press the **SEL** button to accept the changes.



Notification Out

Configuration settings for Notifications.

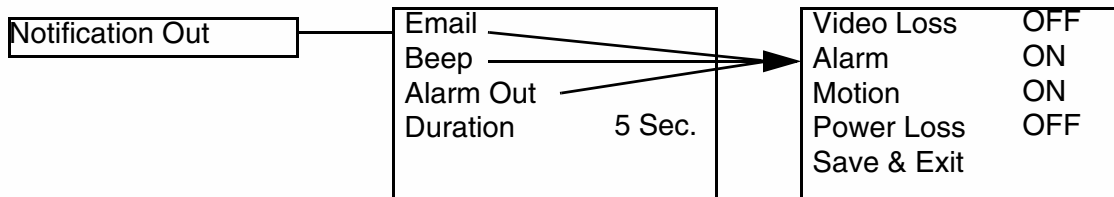

1. **EMAIL:** Specifies an event type to be sent as an automatically generated email. Press the ↑ and ↓ buttons to highlight, and press the **SEL** key to enter the Email submenu:
 - VIDEO LOSS: Sets the Video Loss Event send to ON/OFF
 - ALARM: Sets the Alarm Event send to ON/OFF
 - MOTION: Sets the Motion Event send to ON/OFF
 - POWER LOSS: Sets the Power Loss Event send to ON/OFF
 - SAVE & EXIT: Saves any changes made, and exits to the Main Menu. Press the ↑ and ↓ buttons to highlight, and press the **SEL** button to accept the changes.
2. **BEEP:** Turns the audible alerts ON/OFF when an event is detected. Press the ↑ and ↓ buttons to highlight, and press the **SEL** key to enter the Beep submenu. Options within this menu are the same as the EMAIL SUBMENU above.
3. **ALARM OUT:** Turns the alarm out to ON or OFF when an event is detected. Press the ↑ and ↓ buttons to highlight, and press the **SEL** key to enter the Alarm out submenu. Options within this menu are the same as the EMAIL SUBMENU above.
4. **DURATION:** Specifies the length of time for an event. Press the ↑ and ↓ buttons to highlight, and press the ←→ buttons to change the duration to 5 seconds, 10 seconds or 20 seconds.



USB - Updating the DVR Firmware

Occasionally, updates to the DVR firmware become available on our website. These updates can be installed on your DVR unit using the USB Memory Stick.

1. Download the most current program from the <http://www.digimerge.com> website, and copy it to a Memory Stick. Compatibility has been successfully tested with the Lexar Jumpdrive 128/256 MB, Sandisk Mini Cruiser 128 MB and Cruiser Micro 256MB.
2. Connect the Memory Stick to the USB 2.0 Port on the front panel of the DVR.
3. Enter the Menu by pressing the MENU button on the front panel of the DVR.
 - Select the System Set Option, and choose Program Update
 - NEW PROGRAM FOUND: If the new application is recognized, the DVR unit will display a processing percentage. Reboot the DVR once complete.
 - NEW PROGRAM NOT FOUND: If the application is not recognized, processing will not continue.

Compatible USB Devices

The following USB devices have been tested successfully with the DHU500 Series DVR:

- Lexar Jumpdrive 128/256 MB
- SanDisk Mini Cruiser 128 MB
- SanDisk Cruiser Micro 256 MB



The Benchmark for Value in CCTV

SECTION 5

NETWORK CONNECTIVITY



Network Connectivity	48
Router Port Forwarding	50
Setting Up Your DDNS Account	51
Setting Up DDNS on the DRV	53

DIGIMERGE™



Network Connectivity

The DVR unit can be controlled using your existing network and a PC. The DVR Unit can be controlled from within your network, or can also be controlled remotely through the Internet.

1. Connect the DVR to the Router.
Power the DVR on.

NOTE: It is recommended that the DVR be connected to the router prior to powering on the system.

The DVR can be automatically assigned an IP address by the router (and other network related settings), or an IP address can be manually assigned within the MENU - NETWORK setup on Page 40.

2. Enable **PORT FORWARDING** on your Router. Refer to the instructions on Page 50 for details.

3. Set up a web account at <http://DDNS.digimerge.net>. Refer to Pages 51-53 for setup and configuration instructions.

4. Access the DVR Software with either a Local PC or Remote PC using Microsoft Internet Explorer 5 (or higher). See the Operator's Manual for details.

NOTE: Microsoft IE is the **ONLY** supported browser at this time.

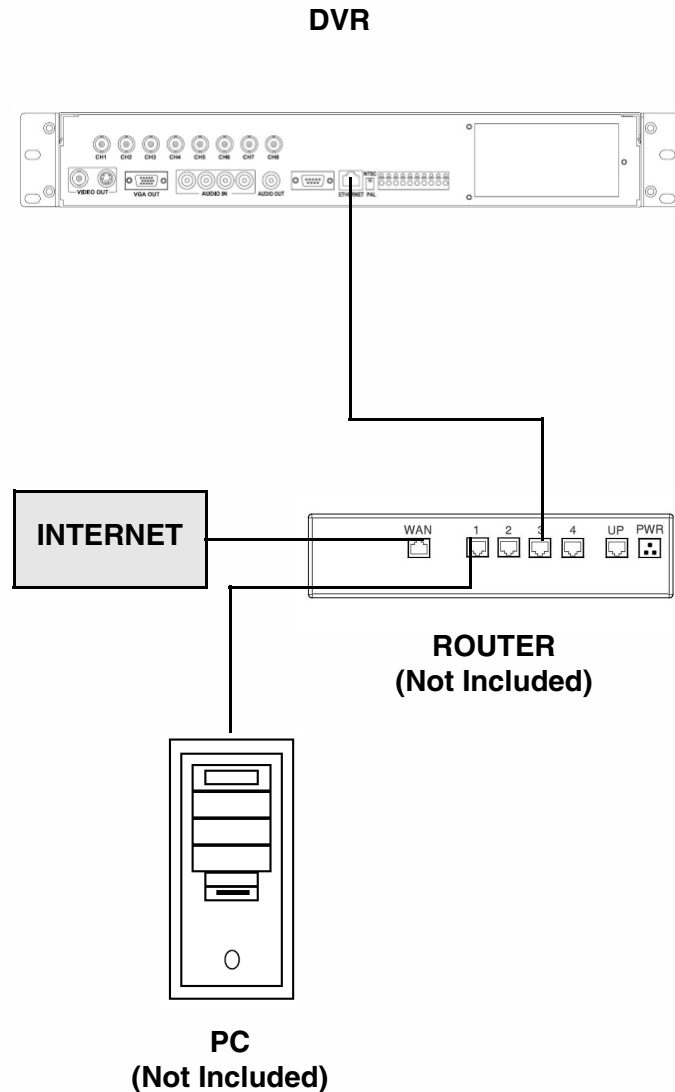



DVR Network Settings

Network Related settings for the DVR unit are set through the Menu options. See Page 36 for IP Set Menu options.

1. Press the Menu button on the front panel of the DVR. Select the Network Set option, and select the IP Set option.

- Set the DHCP option to either YES or NO. Setting the option to YES will let the unit get Network information from the router, and setting the option to NO will allow the user to set this information manually.

- Setup the IP Address, Gateway and NetMask manually, or allow the DVR to retrieve these settings from the Router.

- Set the DVR PORT to 2000 (or any other port desired between 2001 ~ 65535 that is not currently in use).

- Set the WEBSERVER PORT to 80 (or any other port desired between 2001 ~ 65535 that is not currently in use). If you use a port other than 80, you will need to include this port number when accessing your DVR through Internet Explorer.

For example, if the DVR IP Address is 192.168.0.150, and the Webserver Port is set to 2005, use the following address on the Internet Explorer browser to access the DVR:

- <http://192.168.0.150:2005>

NOTE: The Ports specified above will need to be forwarded in the Router Settings.

2. Select SAVE & EXIT to save the changes.

DHCP:	NO
IP Address:	###.###.###.###
Gateway:	###.###.###.###
Netmask:	###.###.###.###
DNS Server:	###.###.###.###
DVR Port:	2000
Webserver Port:	0080
Save & Exit	



Router Port Forwarding

You will need to enable port forwarding on your Router to allow for external communications with your DVR. The following ports will need to be forwarded to remotely connect to your DVR:

- DVR PORT: 2000 (or any other port you selected to use during setup)
- WEBSERVER PORT: 80 (or any other port you selected to use during setup)

Computers, DVRs, and other devices inside your network can only communicate directly with each other within the internal network. Computers and systems outside your network cannot directly communicate with these devices. When a system on the internal network needs to send or receive information from a system outside the network (i.e. from the Internet), the information is sent to the Router.

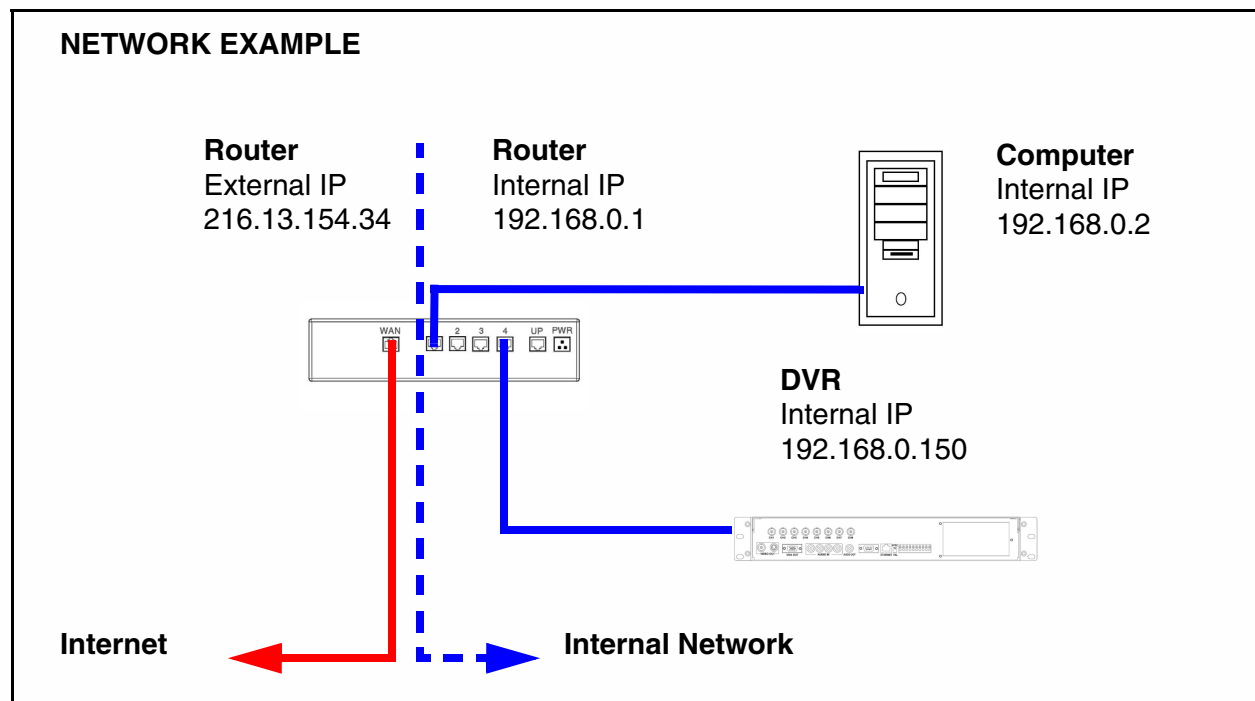

When a computer on the Internet needs to send data to your internal network, it sends this data to the external IP address of the Router. The Router then needs to decide where this data is to be sent to. This is where setting up Port Forwarding becomes important.

Port Forwarding tells the router which device on the internal network to send the data to. When you set up port forwarding on your Router, it takes the data from the external IP address:port number and sends that data to an internal IP address:port number (i.e. **Router External IP 216.13.154.34:2000 to DVR Internal IP 192.168.0.3:2000**).

The instructions found online in the [Router Configuration Guide](#) or at <http://www.portforward.com> will assist you in the port forwarding configurations for a selection of different router models. Visit our website at <http://www.digimerge.com> for more details



Setting Up Your DDNS Account

Digimerge offers a free DDNS server for use with your System. A DDNS account allows you to set up a web site address that points back to your Local Network. The following outlines how to set up your free DNS account.

1. Navigate to <http://DDNS.digimerge.net>
2. Select the **Create Account** option from the list on the left side of the screen.

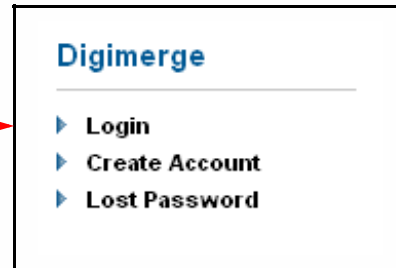

3. Complete the **Account Information** fields with your personal information

Create New Account

Account Information

E-mail	<input type="text" value="email@mailhost.com"/>
Password	<input type="password" value="••••••"/>
Password confirm	<input type="password" value="••••••"/>
First name	<input type="text" value="Tom"/>
Last name	<input type="text" value="Smith"/>
Region	<input type="text" value="Ontario"/> ▼
Country	<input type="text" value="Canada"/> ▼
Timezone	<input type="text" value="Eastern Standard Time (EST)"/> ▼

By clicking on "Create New Account" you accept the [Terms of Service](#).



4. Complete the **System Information** fields as follows:

PRODUCT LICENSE SECTION:

- **Product Code:** Select your product model from the **Product Code** drop down menu
- **<Product Code> - <MAC Address>:** Locate the MAC address of your System by pressing the Info button on the Remote (or from the menu).

Select Product Code ▾

DHX308301

DHX316301

DHY504161

DHY504301

DHU504161

DHU504301

DHU504401

DHU508161

DHU508301

DHU508401

DHU516161

DHU516301

DHU516401

URL REQUEST SECTION:

- **URL Request:** Choose a **URL** for your **DDNS** connection (i.e. your name, your company or business name, or anything of your choice.)

NOTE: The URL request must not exceed 8 CHARACTERS

5. Click the **Create New Account** link at the bottom of the form to submit your request.

System Information

Product License ▾ - <Product Code> - <MAC Address>

URL Request .digimerge.net What is this?

[Create New Account](#)

6. Your **Account** information will be sent to you at the **E-mail Address** you used in **Step 3**.

Domain name: tomsmith

User name: tomsmith1

Password: 1234

You will need this information for remote access to your System. Record **YOUR** information below:

Domain Name: _____

User Name: _____

Password: _____

NOTE: The information sent to you in E-mail is **CASE SENSITIVE**. It is important when setting up your **DDNS** information on your DVR.



Setting up DDNS on the DVR

Once the DDNS Account has been configured (and the account details received in Email), then these settings can be added to the DVR unit. See the DDNS Set menu options on Page 35 for further details.

1. Press the Menu button on the front panel of the DVR. Select the Network Set option, and select the DDNS Set option.

- Set DDNS to YES (if using remote access to the DVR. Otherwise, leave this option as NO).
- Setup the Domain Name, User Name and Password manually, based on the settings received in email.

DDNS:	YES
Domain Name:	#####
User Name:	#####
Password:	#####
DDNS Status Check	
Save & Exit	

NOTE: When you configure your DDNS information, only the first part of the address needs to be input (i.e. dhu504.digimerge.net - for the Domain Name entry, only enter dhu504).

- Select the DDNS Status Check to confirm that the DDNS Service can be reached. An error message will be displayed if a connection cannot be reached.

2. Select SAVE & EXIT to save the changes.

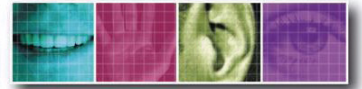

The Benchmark for Value in CCTV

SECTION 6

TROUBLESHOOTING



Troubleshooting 56

DIGIMERGE™



Troubleshooting

When a malfunction occurs, it may not be serious and can be easily corrected. The following describes the most common problems and solutions. Please refer to the following before calling your DVR dealer

Problem:

DVR Unit is not receiving power, or is not powering up

Check:

- Confirm that all cables are connected correctly
- Confirm that the ON/OFF (I/O) switch on the rear of the unit (beside the power cable connection) is ON (in the I position)
- Confirm that there is power at the outlet:
 - Connecting the power cable to another outlet
 - Test the outlet with another plugged device (such as an electric calculator or phone charger)
- If the unit is connected through a power bar or surge protector, try bypassing the bar and connecting the power directly to the wall outlet

Problem:

DVR is not responding when any of the buttons are pushed.

Check:

- Turn the master power switch OFF using the (I/O) switch on the rear of the unit (beside the power cable connection):
 - Press the (I/O) switch to the OFF position (O)
 - Wait for 1 minute - all LED light indicators on the front of the unit will be off
 - Press the (I/O) switch to the ON position (I)
- The unit will make an audible alert when powered back on

Problem:

There is no picture appearing on a Channel / Camera is not displaying

Check:

- Check the camera video cable and connections - Disconnect and reconnect the cable at the DVR and at the Camera
- Try moving the camera to another channel or use another cable
- Check if the Camera is in COVERT mode.

**Problem:**

The message "Can't display page is shown when failing to connect to DVR (when inputting the IP Address or Domain Name in the Internet Explorer).

Check:

- Check the network connection
- Try connecting the DVR to a different port on the Router
- The DVR may not have the correct Network Settings. Refer to Technical Support.

Problem:

Cannot download the Active X Controls (when using Internet Explorer).

Check:

- Check that Windows XP Service Pack 2 is installed on the PC
- The DVR may not have the correct Network Settings. Refer to Technical Support.

Problem:

The Client Program is terminated with the error message "Unsupported OS version!".

Check:

- The client program only works on Window XP and Windows 2000. It does not support Windows 98, 98SE, or ME

Problem:

The Client Login box appears, and does not accept the User ID and Password.

Check:

- This happens when the User ID and Password are not correct. Check the exact ID and Password on the DVR unit.



The Benchmark for Value in CCTV

APPENDIX 1

DVR SPECIFICATIONS



DVR Specifications 60

DIGIMERGE™



DVR Specifications

Model		MPEG-4 Digital Video Recorder			
		4CH	8CH	16CH	
Video	Camera Input(Ntsc,Pal)	4	8	16	
	Output	1 BNC, 1 S-Video, 1 VGA			
Audio	Audio Input	1 RCA	4 RCA		
	Output	1 RCA			
Sensor in (No.Nc)/ Alarm Out		4/1			
Operating System		Embedded Linux OS			
Display	Speed	120fps	240fps	480fps	
	Resolution(Pixel)	720*240, 360*240(NTSC) / 720*288, 360*288(PAL)			
	Split Screen	1,4	1,4,8 SEQ	1,4,8,16 SEQ	
Recording	Compression	MPEG-4			
	Resolution(Pixel)	720*240, 360*240(NTSC) / 720*288, 360*288(PAL)			
	Picture Quality	3 Steps (High, Middle, Low)			
	Mode	Normal, Motion, Alarm, Schedule			
	Priority	Alarm -> Motion -> Schedule -> Normal			
	Speed	Total	120fps(360*240), 60fps(720*240) / 100fps(360*288), 50fps(720*288)		
		Each Chanel	NTSC	30fps(360*240) 15fps(720*240)	15fps(360*240) 7.5fps(720*240)
			PAL	25fps(360*288) 12.5fps(720*288)	12.5fps(360*288) 6.25fps(720*288)
				7.5fps(360*240) 3.75fps(720*240)	6.25fps(360*288) 3.125fps(720*288)
	Water Marking & Scrambling		YES		
Playback	Display	1,4	1,4,8	1,4,8,16	
	Search Mode	Date & Time, Calendar			
	Speed	Normal, REW & FF(Recorded Speed *2, *4, *16), Frame to Frame, Pause			
	Device	Internal HDD			
	Still Image Capture & Save	JPEG Compression or AVI Fromat & USB I/F Device(Memory Stick)			
Network	Network Interface	Ethernet			
	Protocol	TCP/IP, SMTP, HTTP, DHCP, PPPOE(ADSL)			
	Serial Communicaton	No	RS-232 1Each, RS-485 1Each		
	Application	Windows 2000 / XP(PC Client System)			
	Web Browser	Internet Explorer 5.0 Higher(DVRs Contorl or Viewing)			
Back Up	Event Transport	When Event Occur, Set send to e-mail.			
	Interface	USB 2.0			
Control	Backup Device	External HDD, CD/DVD-RW, Network, Memory Stick, Internal CD/DVD-RW			
	Motion Detection	Each Control / Channel			
		Sensitivity : 3 Steps for each channel			
		Area : Individually Programmable motion detection area for each camera			
	Alarm Hold Time	5~240 SEC			
	Event Log	Up to 256 events(Alarm,Motion,Video&Power Loss,Power&Record On/Off			
	Remote Controller	IR Remote Control			
Pan/Tilt Camera	Control From RS485 Interface				
Others	HDD	Supports Max. *2HDD			
	Power Source	100~240V AC, 50~60HZ			
	Power Consumption	36W	70W		
	Operating Temperature	5~40°C(41~104F)			
	Relative Humidity	Maximum 80% Non-Considering			
	Weight	Net	7.0Kg		
		Gross(Box)	7.5Kg		
	Dimension	Net	450(W)*370(D)*90(H)mm		
Gross(Box)		500(W)*460(D)*190(H)mm			



The Benchmark for Value in CCTV

APPENDIX 2

CONNECTING MOTION/ALARM DEVICE



Connection Motion/Alarm Device 62

DIGIMERGE™



Connecting Motion / Alarm Device

Motion detection and Alarm controls are enabled through the Menu system on the DVR. Additional motion sensor devices can be connected to the system (Motion Sensors, Door/Window Sensors).

A motion detection or sensor unit can be used to send a signal to the DVR to begin camera recording on the selected Video Channel (when enabled in the Alarm Recording Menu)

- Example: A Window sensor unit has been installed on Alarm Block port #4. When this sensor is activated, the camera on port #4 will start recording (if enabled in the MENU on the DVR)

For the corresponding Menu Programming, refer to Page 30.

Installing a Sensor

1. Connect the GROUND Cable to the GND port on the Alarm Block on the DVR

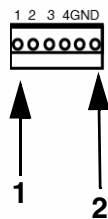

2. Connect the SIGNAL Cable to a numbered port (1-4)

To start ALARM RECORDING on a DVR, refer to the RECORDING SET section of the manual.

DVR

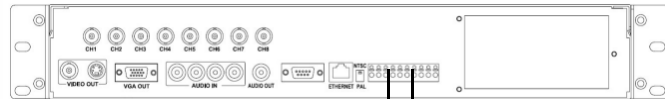

SENSOR
(Not Included)

Limited Warranty

Warranty: Subject to the exclusions and limitations below, Digimerge warrants to the initial end-user purchaser that the product will be free from defects in material and workmanship for a period of one year from the date of purchase. **Effective September 1, 2006: For all purchases after September 1, 2006, Digimerge warrants that the hard drive(s) will be free from defects in material and workmanship for a period of three years from the date of purchase.** For valid warranty claims made during the warranty period, upon proof of purchase, defective products will, at the election of Digimerge, be repaired or replaced without charge. Any products repaired or replaced within the warranty period, shall be warranted by Digimerge to the initial end-user purchaser for 90 days from the return shipment date, or the remainder of the warranty term, whichever is longer, and if outside of the warranty period then for 90 days from the return shipment date. Products and parts may be replaced with refurbished items, and the products and parts replaced become the property of Digimerge. You are responsible for all shipping costs associated with the return of the defective products for warranty service.

Exclusions and Limitations: Any of the following will void this warranty:

- I. Installation or use of the product other than strictly in accordance with the instructions contained in the product's instruction manual;
- II. If the product is subjected to operating conditions (including atmospheric, moisture and humidity conditions) outside of the acceptable conditions specified in the product's instruction manual;
- III. If the product is subjected to misuse or abuse;
- IV. If the product is subjected to electrical short circuits or transients, accident, fire, flood or Acts of God;
- V. Adjustment, maintenance or repair of the product other than in accordance with Digimerge approved procedures; and
- VI. Use of replacement parts other than those specified by Digimerge.

DIGIMERGE MAKES NO CLAIMS OR WARRANTIES OF ANY KIND WHATSOEVER REGARDING THE PRODUCT'S ABILITY OR EFFECTIVENESS IN PREVENTING OR REDUCING THE RISK OF, OR DAMAGES RESULTING FROM, LOSS OR THEFT OF PROPERTY OR PERSONAL INJURY. THIS LIMITED WARRANTY IS IN LIEU OF ALL OTHER WARRANTIES, EXPRESS OR IMPLIED, INCLUDING, BUT NOT LIMITED TO, ANY IMPLIED WARRANTY OF MERCHANTABILITY OR FITNESS FOR A PARTICULAR USE OR PURPOSE. REPAIR OR REPLACEMENT AS PROVIDED UNDER THIS LIMITED WARRANTY IS THE EXCLUSIVE REMEDY OF THE PURCHASER. DIGIMERGE SHALL IN NO EVENT BE LIABLE FOR ANY SPECIAL, INDIRECT, INCIDENTAL, PUNITIVE, OR CONSEQUENTIAL DAMAGES OF ANY KIND OR CHARACTER, INCLUDING, WITHOUT LIMITATION, PERSONAL INJURY, LOSS OF REVENUE OR PROFITS, FAILURE TO REALIZE SAVINGS OR OTHER BENEFITS, OR CLAIMS AGAINST THE PURCHASER BY ANY THIRD PERSON, EVEN IF DIGIMERGE HAS BEEN ADVISED OF THE POSSIBILITY OF SUCH DAMAGES.

No claims or statements regarding the product, whether written or verbal, by salespeople, retailers, dealers or distributors, that are not contained in this limited warranty or in the owner's manual are authorized by Digimerge and do not modify or expand this warranty. Some countries, states, or provinces do not allow the exclusion or limitation of implied warranties or the limitation of incidental or consequential damages for certain products supplied to consumers or the limitation of liability for personal injury. To the extent that such restrictions on limitations apply to the products, the above limitations and exclusions may be limited in their application. In that case, when the implied warranties are not allowed to be excluded in their entirety, they will be limited to the duration of the applicable written warranty, and if damages may not be limited then the above limitations on damages apply, but only to the greatest extent permitted by local law.

Warranty and Non-Warranty Service: Contact the dealer that sold you this product, during the warranty period if applicable, to obtain service. Non-warranty service is subject to the then current Digimerge service terms and prices. If the dealer fails to respond, cannot be reached or fails to provide you with the required service, you may obtain service directly from Digimerge by calling our service department at (866) 344-4674. You must provide Digimerge with the defective product's model number, serial number, date of purchase, sales or invoice number, proof that you were the original end-user purchaser for warranty work, and a brief description of the problem. You must obtain a return authorization number from the service department and must mark the number clearly on the shipping box. You must ship the item prepaid in appropriate packaging to the following address:

Digimerge Technologies Inc.,
Attention: Repair Department,
300 Alden Rd,
Markham, Ontario, Canada,
L3R 4C1

OR

For a depot nearest you, please view our website at <http://www.Digimerge.com> and click on the Technical Support link.

It's all on the web

 **Product Information**

 **Specification Sheets**

 **User Manuals**

 **Software Upgrades**

 **Quick Start Guides**

 **Firmware Upgrades**



VISIT
www.digimerge.com

www.digimerge.com

Digimerge Technologies Inc.

Free Manuals Download Website

<http://myh66.com>

<http://usermanuals.us>

<http://www.somanuals.com>

<http://www.4manuals.cc>

<http://www.manual-lib.com>

<http://www.404manual.com>

<http://www.luxmanual.com>

<http://aubethermostatmanual.com>

Golf course search by state

<http://golfingnear.com>

Email search by domain

<http://emailbydomain.com>

Auto manuals search

<http://auto.somanuals.com>

TV manuals search

<http://tv.somanuals.com>