

INSTALLATION AND SERVICE MANUAL

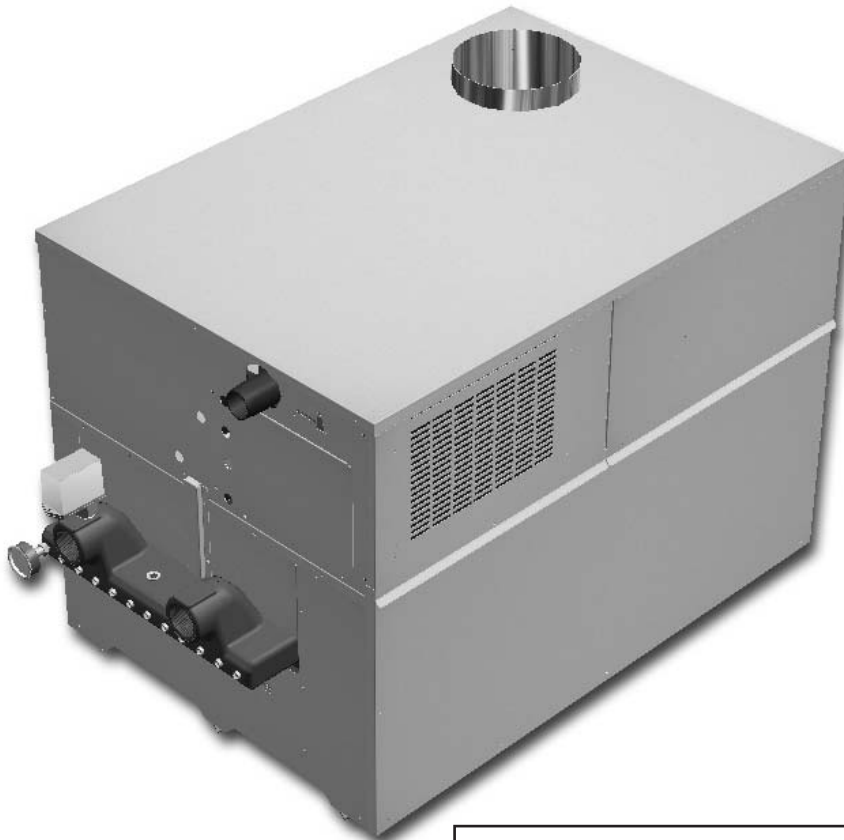

HYDRONIC HEATING BOILERS and DOMESTIC WATER HEATERS 495,000 - 2,065,000 Btu/hr MODELS



⚠ WARNING: Do not use this appliance if any part has been under water. The possible damage to a flooded appliance can be extensive and present numerous safety hazards. Any appliance that has been under water must be replaced.

⚠ WARNING: Improper installation, adjustment, alteration, service or maintenance can cause property damage, personal injury, exposure to hazardous materials or loss of life. Refer to this manual. Installation and service must be performed by a qualified installer, service agency or the gas supplier. This unit contains materials that have been identified as carcinogenic, or possibly carcinogenic, to humans.

⚠ WARNING: If the information in this manual is not followed exactly, a fire or explosion may result causing property damage, personal injury or loss of life.

– Do not store or use gasoline or other flammable vapors and liquids in the vicinity of this or any other appliance.

WHAT TO DO IF YOU SMELL GAS

- Do not try to light any appliance.
 - Do not touch any electric switch; do not use any phone in your building.
 - Immediately call your gas supplier from a neighbors phone. Follow the gas supplier's instructions.
 - If you cannot reach your gas supplier, call the fire department.
- Installation and service must be performed by a qualified installer, service agency or the gas supplier.

Save this manual for future reference.

Hydronic Heating Boilers and Domestic Water Heaters

Table of Contents

General Product Information	3
Special Instructions	3
Unpacking	3
Codes	3
Warranty	3
Safety Information	3
Product Identification	5
Installation	6
Locating Unit	6
Clearances from Combustible Construction	6
Base for Combustible Floors	6
Freeze Protection	7
Pump Operation	7
Location	7
Hydronic System Antifreeze	7
Outdoor Boiler Installation	7
Shutdown and Draining	7
Freeze Protection for a Heating Boiler System	8
Combustion and Ventilation Air	8
Combustion Air Filter	8
Combustion Air Options	9
Exhaust Fans	10
Venting	10
General Information	10
Venting Support	10
Vertical Vent Termination Clearances and Location	10
Vent System Options	12
Barometric Damper Location	12
1. Conventional Negative Draft Venting	13
2. Outdoor Installation Venting	14
Connecting to Gas Supply	16
Gas Pressure Test	16
Gas Piping	16
Connecting Gas Piping to Unit	17
Gas Train and Controls	17
Combination Gas Valves	18
Venting of Combination Gas Valves	18
Checking Gas Supply Pressure	18
Gas Manifold Pressure Adjustment	19
Connecting to Water Supply	20
Inlet and Outlet Connections	20
Relief Valve	21
Water Flow Switch	21
Low Water Cutoff	21
Connecting to Electrical Supply	21
Terminal Strip Connection Options	22
Boiler System Piping	23
Primary/Secondary Boiler Piping	24
Low Temperature Return Water Systems	25
Radiant Floor and Snow Melt Heating Systems	25

Table of Contents

Installation with a Chilled Water System	26
Boiler Flow Rate	27
Boiler Bypass Requirements	27
Temperature/Pressure Gauge	27
Filling the System	27
Water Treatment	28
Operation	28
Lighting Instructions	28
To Turn Off Gas To Appliance	29
Setting Temperature Control	29
Locating Temperature Control	29
Temperature Control Settings	30
Outdoor Air Reset Option	31
Boiler Operating Temperature Control	31
Temperature Control Sensors	32
Placement of Sensors	32
Remote Mounting of Sensor	33
Hot Surface Ignition System	33
Operation and Diagnostic Lights	35
Domestic Water Heaters	36
Water Velocity Control	36
Water Chemistry	37
Pipe Size Requirements	37
Circulating Pump	37
Minimum Pump Performance	38
Heat Exchanger	38
Potable Hot Water Temperature Control Settings	38
Location of Cold Water Supply Piping Connections	39
High Water Temperature Limit Control	39
Optional Relief Valve	39
Thermal Expansion	39
Cathodic Protection	39
Cleaning and Maintenance	40
Flue Gas Passageways Cleaning Procedures	40
Burner Removal and Cleaning	40
Heat Exchanger Cleaning	41
Electrical	41
Combustion and Ventilation Air	41
Adjusting Differential Air Pressure	41
Servicing Hot Surface Igniter and Ignition Module	43
Ignition System Checkout	44
Sequence of Operation	44
Glossary	45
Schematic/Wiring Diagrams	47
Revision Notes	Back Cover

Installation and Service Manual

GENERAL PRODUCT INFORMATION

Special Instructions

This manual supplies information for the installation, operation and servicing of the appliance. Read and understand this manual completely before installing unit.

Installation and service must be performed by a qualified service installer, service agency, or the gas supplier.

Unpacking

Upon receiving equipment, check for signs of shipping damage. Pay particular attention to parts accompanying the boiler which may show signs of being hit or otherwise being mishandled. Verify total number of pieces shown on packing slip with those actually received. In case there is damage or a shortage, immediately notify the carrier.

Codes

The equipment shall be installed in accordance with those installation regulations in force in the local area where the installation is to be made. These shall be carefully followed in all cases. Authorities having jurisdiction shall be consulted before installations are made. In the absence of such requirements, the installation shall conform to the latest edition of the National Fuel Gas Code, ANSI Z223.1 and/or CAN/CGA-B149 Installation Code. Where required by the authority having jurisdiction, the installation must conform to American Society of Mechanical Engineers Safety Code for Controls and Safety Devices for Automatically Fired Boilers, ASME CSD 1. All boilers conform to the latest edition of the ASME Boiler and Pressure Vessel Code, Section IV.

Warranty

Factory warranty (shipped with unit) does not apply to units installed or operated improperly.

In most cases, improper installation or system design causes most operating problems.

1. Excessive water hardness causing a lime build up in the copper tube is not the fault of the equipment and is not covered under the appliance manufacturer's warranty (see *Water Treatment*, page 28 and *Water Chemistry*, page 37).
2. Excessive pitting and erosion on the inside of the copper

tube may be caused by too much water velocity through the tubes and is not covered by the appliance manufacturer's warranty (see *System Temperature Rise Chart* on page 26 for flow requirements).

SAFETY INFORMATION

The information contained in this manual is intended for use by qualified professional installers, service technicians or gas suppliers. Consult your local expert for proper installation or service procedures.

IMPORTANT: Read this owner's manual carefully and completely before trying to install, operate, or service this unit. Improper use of this unit can cause serious injury or death from burns, fire, explosion, electrical shock, and carbon monoxide poisoning.

⚠ DANGER: Carbon Monoxide poisoning may lead to death!

IMPORTANT: Consult and follow local building and fire regulations and other safety codes that apply to this installation. Consult your local gas utility company to authorize and inspect all gas and flue connections.

⚠ WARNING: Should overheating occur or the gas supply fail to shut off, do not turn off or disconnect the electrical supply to the pump. Instead, shut off the gas supply at a location external to the unit.

⚠ WARNING: To minimize the possibility of serious personal injury, fire or damage to your unit, never violate the following safety rules.

1. This unit is only for use with the type of gas indicated on the rating plate.
2. If you smell gas
 - shut off gas supply
 - do not try to light any appliance
 - do not touch any electrical switch; do not use any phone in your building
 - immediately call your gas supplier from a neighbor's phone. Follow the gas supplier's instructions
 - if you cannot reach your gas supplier, call the fire department

Hydronic Heating Boilers and Domestic Water Heaters

3. Boilers and water heaters are heat producing appliances. To avoid damage or injury, do not store materials against the appliance or the vent-air intake system. Use proper care to avoid unnecessary contact (especially children) with the appliance and vent-air intake components. Follow all clearances from combustibles contained in this manual.
4. Never cover your unit, lean anything against it, store trash or debris near it, stand on it or in any way block the flow of fresh air to your appliance.
5. UNDER NO CIRCUMSTANCES must flammable materials such as gasoline or paint thinner be used or stored in the vicinity of this appliance, vent-air intake system or any location from which fumes could reach the appliance or vent-air intake system.
6. Appliance surfaces become hot during operation. Be careful not to touch hot surfaces. Keep all adults, children, and animals away from an operating hot unit. Severe burns can occur.
7. You must take adequate care to prevent scald injury when storing water at elevated temperatures for domestic use.
8. This unit must have an adequate supply of fresh air during operation for proper gas combustion and venting.
9. Make sure all exhaust venting is properly installed and maintained. Improper venting of this unit could lead to increased levels of carbon monoxide.
10. Do not use this boiler if any part has been under water. Immediately call a qualified service technician to replace the boiler. The possible damage to a flooded boiler can be extensive and present numerous safety hazards. Any appliance that has been under water must be replaced.
11. Do not alter this unit in any way. Any change to this unit or its controls can be dangerous.

Installation and Service Manual

PRODUCT IDENTIFICATION



Front View



Rear View

Figure 1 – Front and Rear View

Hydronic Heating Boilers and Domestic Water Heaters

INSTALLATION

This unit meets the safe lighting performance criteria with the gas manifold and control assembly provided, as specified in the ANSI standards for gas-fired units, ANSI Z21.13/CSA 4.9 and ANSI Z21.10.3/CSA 4.3.

LOCATING UNIT

1. Maintain all clearances from combustible construction when locating unit. See *Clearances from Combustible Construction*, this page.
2. Locate the unit so that if water connections should leak, water damage will not occur. When such locations cannot be avoided, install a suitable drain pan that is well-drained under the unit. The pan must not restrict combustion air flow. The appliance manufacturer is not responsible for water damage in connection with this unit, or any of its components.
3. Install indoor units so that the ignition system components are protected from any water while operating or during service.
4. Appliances located in a residential garage and in adjacent spaces that open to the garage and are not part of the living space of a dwelling unit must be installed so that all burners and burner ignition devices have a minimum clearance of not less than 18" (46cm) above the floor. The appliance must be located or protected so that it is not subject to physical damage by a moving vehicle.
5. DO NOT install this appliance in any location where gasoline or flammable vapors are likely to be present.
6. You must install unit on a level, non-combustible floor.
7. Do not install unit directly on carpet or other combustible material. A concrete-over-wood floor is not considered non-combustible. Maintain required clearances from combustible surfaces.

If installing unit in an area with a combustible floor, you must use a special combustible floor base. See *Base for Combustible Floors*, this page.
8. For outdoor models, you must install an optional vent kit. Instructions for mounting the vent kit are included in the venting section. Do not install outdoor models directly on the ground. You must install the outdoor unit on a concrete, brick, block, or other non-combustible pad. Outdoor models have additional special location and clearance requirements. See *Outdoor Installation Venting*, page 14. A wind proof cabinet protects the unit from weather.

Clearances from Combustible Construction

Maintain minimum specified clearances for adequate operation. Allow sufficient space for servicing pipe connections, pump and other auxiliary equipment, as well as the unit. See rating plate for specific service clearance requirements.

Right Side	3" (7.5 cm)
Rear	3" (7.5 cm) (3" min. from any surface)
Left Side	6" (15cm)(24" (0.61m) suggested for service)
Front	Alcove* (30" (0.76m) suggested for service)
Top	3" (7.5cm)
Flue	1" (25.4mm)
Hot Water Pipes	1" (25.4mm)

*An Alcove is a closet without a door.

Note: No additional clearance is needed on the right side of the unit for the observation port. An observation port is located on both the right and left side of the unit.

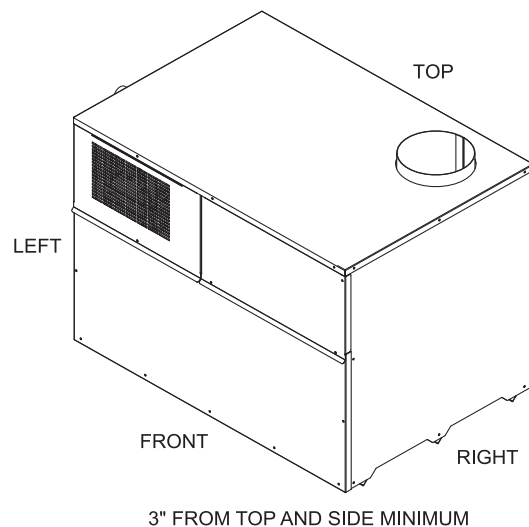

Figure 2 - Clearances from Combustible Construction

Base for Combustible Floors

There is no manufactured combustible floor base kit available for 985,000 - 2,065,000 Btu/hr models. You must construct a

Installation and Service Manual

base for combustible floor installation. Install unit over a base of hollow clay tiles or concrete blocks from 8" to 12" thick and extending at least 24" beyond the unit sides. Place tiles or blocks so that the holes line up horizontally to provide a clear passage through the tiles or blocks. Place a 1/2" fireproof millboard over the top of the tile or block base. Place a 20-gauge sheet metal cover over the fireproof millboard. Center the unit on the base. Also follow this procedure if electrical conduit runs through the floor beneath the unit. This base must meet all local fire and safety codes.

TABLE - A COMBUSTIBLE FLOOR KITS	
Input Btu/hr	Kit Number
495,000	CFK3302
645,000	CFK3303
745,000	CFK3304

FREEZE PROTECTION

Although these units are CSA International design certified for outdoor installations, such installations are not recommended in areas where the danger of freezing exists. You must provide proper freeze protection for outdoor installations, units installed in unheated mechanical rooms or where temperatures may drop to the freezing point or lower. If freeze protection is not provided for the system, a low ambient temperature alarm is recommended for the mechanical room. Damage to the unit by freezing is non-warrantable.

Anytime the temperature measured at any of the sensors (except the outside air temperature sensor) drops below 40°F, the control turns on the pump contact and the alarm relay. The pump will shut off when both sensors are above 50°F.

Pump Operation

This unit is equipped with a pump delay of 30 seconds. If continuous operation of the pump is desired, the pump must be electrically connected to another circuit. Connection of the pump to this unit will provide intermittent pump delay operation.

Location

Locate indoor boilers and hot water supply boilers in a room having a temperature safely above freezing [32°F (0°C)].

⚠ CAUTION: A mechanical room operating under a negative pressure may experience a down draft in the flue of a boiler which is not firing. The cold outside air pulled down the flue may freeze a heat exchanger. This condition must be corrected to provide adequate freeze protection.

Hydronic System Antifreeze

Freeze protection for a heating boiler or hot water supply boiler using an indirect coil can be provided by using hydronic system antifreeze. Follow the appliance manufacturers instructions. Do not use undiluted or automotive type antifreeze.

Outdoor Boiler Installation

Adequate hydronic system antifreeze must be used. A snow screen should be installed to prevent snow and ice accumulation around the unit or its venting system.

Shut-Down and Draining

If for any reason, the unit is to be shut off, the following precautionary measures must be taken:

1. Shut off gas supply.
2. Shut off water supply.
3. Shut off electrical supply.
4. Drain the unit completely. Remove one threaded plug or bulbwell from the inlet side of the front header and one from the outlet side of the front header on the heat exchanger. Blow all water out of the heat exchanger (see Figure 3).
5. Drain pump and piping.

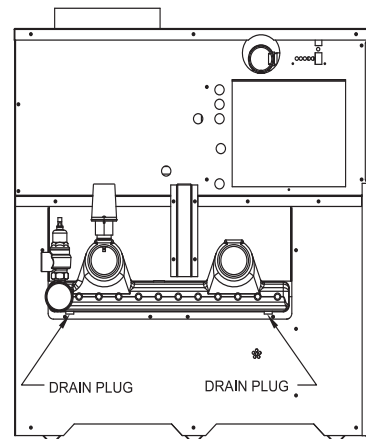

Figure 3 - Draining Unit

Hydronic Heating Boilers and Domestic Water Heaters

INSTALLATION

Continued

Freeze Protection for a Heating Boiler System (if required)

1. Use only properly diluted inhibited glycol antifreeze designed for hydronic systems. Inhibited propylene glycol is recommended for systems where incidental contact with drinking water is possible.

⚠ WARNING: Do not use undiluted or automotive type antifreeze.

2. A solution of 50% antifreeze will provide maximum protection of approximately -30°F.
3. Follow the instructions from the antifreeze manufacturer. Quantity of antifreeze required is based on total system volume including expansion tank volume.
4. Glycol is denser than water and changes the viscosity of the system. The addition of glycol will decrease heat transfer and increase frictional loss in the boiler and related piping. A larger pump with more capacity (15% to 25% more) may be required to maintain desired flow rates and prevent a noise problem in a glycol system.
5. Local codes may require a back flow preventer or actual disconnect from city water supply when antifreeze is added to the system.

COMBUSTION AND VENTILATION AIR

Provisions for combustion and ventilation air must be in accordance with Section 5.3, Air for Combustion and Ventilation, of the latest edition of the National Fuel Gas Code, ANSI Z223.1, in Canada, the latest edition of CAN/CGA-B149 Installation Code for Gas Burning Appliances and Equipment, or applicable provisions of the local building codes.

Provide properly-sized openings to the equipment room to assure adequate combustion air and proper ventilation when the unit is installed with conventional venting or sidewall venting.

Combustion Air Filter

The 985,000 - 2,065,00 Btu/hr models have a standard air filter(s) located behind the combustion air inlet panel(s). This filter helps ensure clean air is used for the combustion process.

Check this filter every month and replace when it becomes dirty. The filter size is 12" x 16" x 1" (30.5cm x 40.6cm x 2.5cm). You can find this commercially available filter at any home center or HVAC supply store.

Installing Combustion Air Filter

To install the filter(s), remove the combustion air inlet panel(s). The 985,000 - 1,435,000 Btu/hr models have one combustion air inlet panel located on the left front of the unit (see Figure 4). The 1,795,000 and 2,065,000 Btu/hr models have two combustion air inlet panels located on the left and right front of the unit (see Figure 5).

1. Loosen knurled knob at the bottom of the control panel cover.
2. Pull the bottom of the panel(s) out and down to remove.
3. Place filter(s) in opening(s).
4. Replace combustion air inlet panel(s).

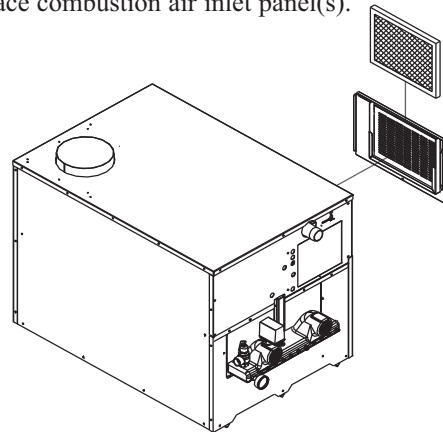

Figure 4 - Installing Combustion Air Filter, 985,000 - 1,435,000 Btu/hr Models

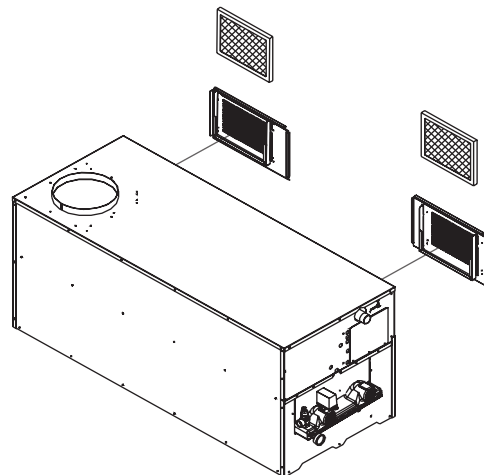

Figure 5 - Installing Combustion Air Filters, 1,795,000 and 2,065,000 Btu/hr Models

Installation and Service Manual

Combustion Air Options

⚠ CAUTION: Under no circumstances should the mechanical room ever be under a negative pressure. Particular care should be taken where exhaust fans, attic fans, clothes dryers, compressors, air handling units, etc., take away air from the unit.

1. Outside Combustion Air, No Ducts You can direct outside combustion air to this unit using either one or two permanent openings.

One Opening

The opening must have a minimum free area of one square inch per 3000 Btu input (7cm^2 per kW). You must locate this opening within 12" (30cm) of the top of the enclosure.

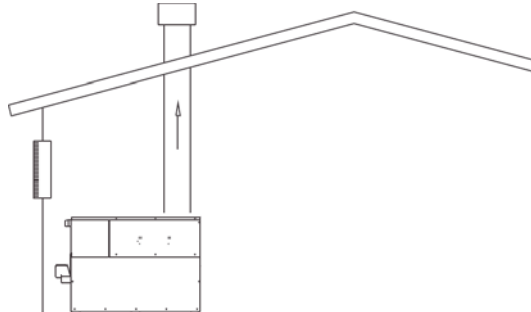

Figure 6 - Outside Combustion Air - Single Opening

Two Openings

The combustion air opening must have a minimum free area of one square inch per 4000 Btu input (5.5cm^2 per kW). You must locate this opening within 12" (30cm) of the bottom of the enclosure.

The ventilation air opening must have a minimum free area of one square inch per 4000 Btu input (5.5cm^2 per kW). You must locate this opening within 12" (30cm) of the top of the enclosure.

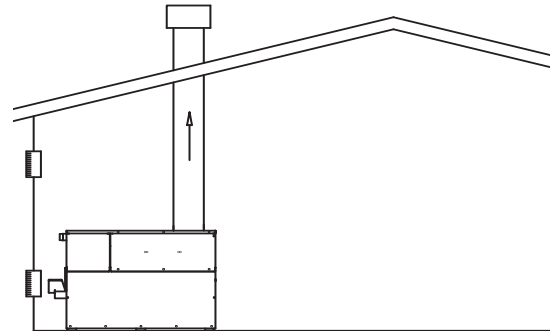

Figure 7 - Outside Combustion Air - Two Openings

2. Outside Combustion Air, Using Ducts

You can direct outside combustion air to this unit using two air ducts to deliver the air to the boiler room.

Each of the two openings must have a minimum free area of one square inch per 2000 Btu input (11cm^2 per kW).

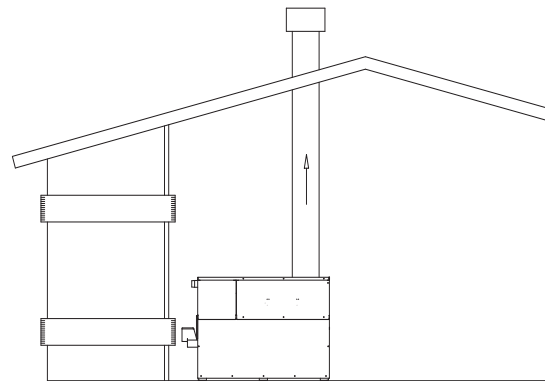

Figure 8 - Outside Combustion Air Through Ducts

3. Combustion Air from Interior Space

You can direct combustion air to this unit using air from an adjoining interior space. You must provide two openings from the boiler room to the adjoining room.

Each of the two openings must have a net free area of one square inch per 1000 Btu input (22cm^2 per kW), but not less than 100 square inches (645cm^2).

Hydronic Heating Boilers and Domestic Water Heaters

INSTALLATION

Continued

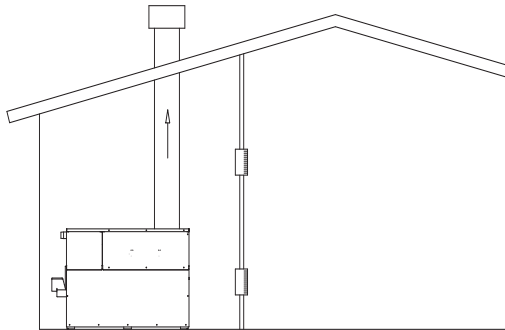

Figure 9 - Combustion Air from Interior Space

All dimensions are based on net free area in square inches. Metal louvers or screens reduce the free area of a combustion air opening a minimum of approximately 25%. Check with louver manufacturers for exact net free area of louvers. Where two openings are provided, one must be within 12" (30 cm) of the ceiling and one must be within 12" (30 cm) of the floor of the mechanical room. Each opening must have a minimum net free area as specified in TABLE-C, page 12. Single openings shall be installed within 12" (30 cm) of the ceiling.

The combustion air supply must be completely free of any flammable vapors that may ignite or chemical fumes which may be corrosive to the appliance. Common corrosive chemical fumes which must be avoided are fluorocarbons and other halogenated compounds, most commonly present as refrigerants or solvents, such as Freon, trichlorethylene, perchlorethylene, chlorine, etc. These chemicals, when burned, form acids which quickly attack the heat exchanger finned tubes, headers, flue collectors, and the vent system. The result is improper combustion and a non-warrantable, premature appliance failure.

Exhaust Fans

Any fan or equipment which exhausts air from the boiler room may deplete the combustion air supply and/or cause a down draft in the venting system. Spillage of flue products from the venting system into an occupied living space can cause a very hazardous condition that must be corrected immediately. If a fan is used to supply combustion air to the boiler room, the installer must make sure that it does not cause drafts which could lead to nuisance operational problems with the boiler.

VENTING

General Information

You must supply adequate combustion and ventilation air to this unit. You must provide minimum clearances for the vent terminal from adjacent buildings, windows that open, and building openings. Follow all requirements set forth in the latest edition of the National Fuel Gas Code, ANSI Z223.1, in Canada, the latest edition of CAN/CGA Standard B149 Installation Code for Gas Burning Appliances and Equipment or applicable local building codes. Vent installations for connection to gas vents or chimneys must be in accordance with Part 7, "Venting of Equipment" of the above-mentioned standards.

IMPORTANT: Examine the venting system at least once each year. Check all joints and vent pipe connections for tightness. Also check for corrosion or deterioration. If you find any problems, correct them at once.

Venting Support

Support horizontal portions of the venting system to prevent sagging. Provide an upward slope of at least 1/4 inch per foot (21mm/m) on all horizontal runs from the unit to the vertical flue run or to the vent terminal on sidewall venting installations.

Do not use an existing chimney as a raceway if another appliance or fireplace is vented through the chimney. The weight of the venting system must not rest on the unit. Provide adequate support of the venting system. Follow all local and applicable codes. Secure and seal all vent connections. Follow the installation instructions from the vent material manufacturer.

Vertical Vent Termination Clearances and Location

The vent terminal should be vertical and exhaust outside the building at least 2 feet (0.61m) above the highest point of the roof within a 10 foot (3.05m) radius of the termination.

The vertical termination must be a minimum of 3 feet (0.91m) above the point of exit.

A vertical termination less than 10 feet (3.05m) from a parapet wall must be a minimum of 2 feet (0.61m) higher than the parapet wall.

Installation and Service Manual

You must locate the air inlet termination elbow at least 12" (30cm) above the roof or above normal snow levels.

Keep the vent cap clear of snow, ice, leaves, and debris to avoid blocking the flue.

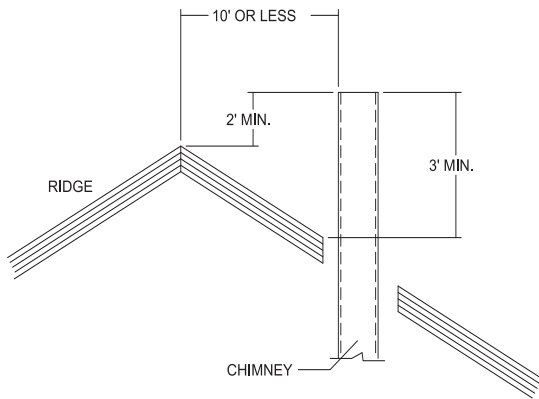

Figure 10 - Vent Termination from Peaked Roof - 10' or Less From Ridge

IMPORTANT: Vent terminations are not shown in Figures 10, 11, 12, and 13. Make sure all vertical vents are installed with vent terminations recommended by the vent manufacturer.

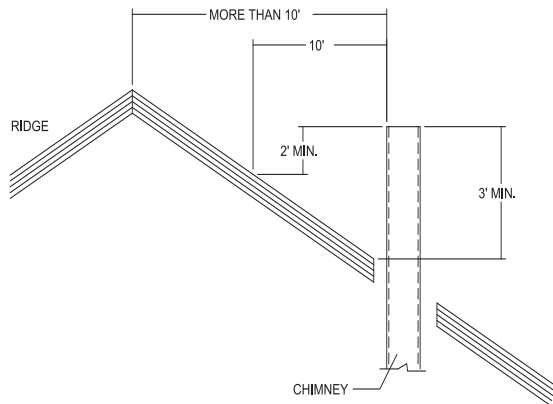

Figure 11 - Vent Termination from Peaked Roof More Than 10' From Ridge

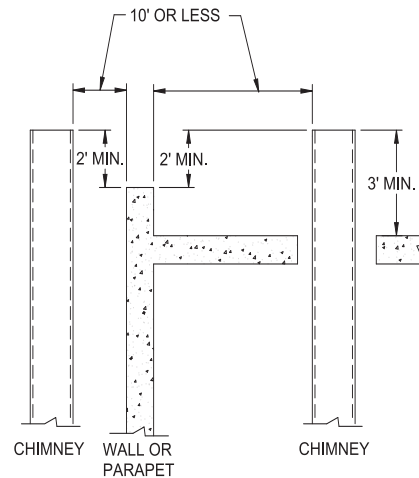

Figure 12 - Vent Termination from Flat Roof 10' or Less from Parapet Wall

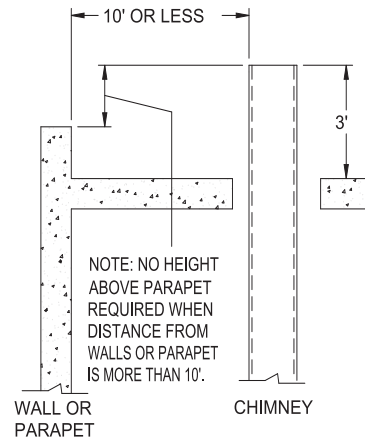

Figure 13 - Vent Termination from Flat Roof More Than 10' from Parapet Wall

⚠ CAUTION: Units which are shut down or will not operate may experience freezing due to convective air flow in the flue pipe, through the air inlet, or from negative pressure in the mechanical room. In cold climates, operate pump continuously to help prevent freezing of boiler water. Provide proper freeze protection. See Freeze Protection, page 7.

Hydronic Heating Boilers and Domestic Water Heaters

INSTALLATION

Continued

TABLE - B Flue Pipe Sizes	
Input Btu/hr	Flue Size
495,000	6"
645,000	8"
745,000	8"
985,000	10"
1,255,000	12"
1,435,000	12"
1,795,000	14"
2,065,000	14"

Vent System Options

This unit has two venting options.

1. Conventional Negative Draft Venting

This option uses a vertical rooftop flue termination. Combustion air is supplied from the mechanical room. See page 13 for detailed information.

2. Outdoor Installation Venting

This option uses the installation of special air inlet and vent caps on the unit. See page 13 for venting details.

All units are shipped from the factory equipped for conventional negative draft venting. All other optional vent systems require the installation of specific vent kits and venting materials. The following is a detailed explanation of the installation requirements for each venting system, components used and part numbers of vent kits for each model.

Barometric Damper Location

Any venting system option that requires a barometric damper must adhere to the following directions for optimum performance.

The preferred location for the barometric damper is in a tee or collar installed in the vertical pipe rising from the unit's flue outlet. The barometric damper **MUST NOT** be installed in a bull head tee installed on the unit's flue outlet. The tee or collar containing the barometric damper should be approximately three feet vertically above the connection to the unit's flue outlet. This location ensures that any positive velocity pressure from the unit's internal combustion fan is dissipated and the flue products are rising due to buoyancy generated from the temperature of the flue products. Adjust weights on damper to ensure that draft is maintained within the specified ranges.

TABLE-C Minimum Recommended Combustion Air Supply To Boiler Room			
Boiler Input	Combustion Air Source		
	Outside Air*/2 Openings	Outside Air*/1 Opening	Inside Air/2 Openings
495,000	125 in ² (806 cm ²)	167 in ² (1077 cm ²)	500 in ² (3226 cm ²)
645,000	163 in ² (1052 cm ²)	217 in ² (1400 cm ²)	650 in ² (4194 cm ²)
745,000	188 in ² (1213 cm ²)	250 in ² (1613 cm ²)	750 in ² (4839 cm ²)
985,000	248 in ² (1,600cm ²)	330 in ² (2,129cm ²)	990 in ² (6,388cm ²)
1,255,000	315 in ² (2,032cm ²)	420 in ² (2,710cm ²)	1260 in ² (8,130cm ²)
1,435,000	360 in ² (2,323cm ²)	480 in ² (3,097cm ²)	1440 in ² (9,291cm ²)
1,795,000	450 in ² (2,903cm ²)	600 in ² (3,871cm ²)	1800 in ² (11,614cm ²)
2,065,000	518 in ² (3,342cm ²)	690 in ² (4,452cm ²)	2070 in ² (13,356cm ²)

*Outside air openings shall directly communicate with the outdoors. When combustion air is drawn from the outside through a duct, the net free area of each of the two openings must have twice (2 times) the free area required for Outside Air/2 Openings. The above requirements are for the boiler only, additional gas fired units in the boiler room will require an increase in the net free area to supply adequate combustion air for all units. Combustion air requirements are based on the latest edition of the National Fuel Gas Code, ANSI Z223.1, in Canada refer to CAN/CGA-B149 Installation Code. Check all local code requirements for combustion air.

Installation and Service Manual

1. Conventional Negative Draft Venting

IMPORTANT: Before installing a venting system, follow all venting clearances and requirements found in the *Venting, General Information* section, page 10.

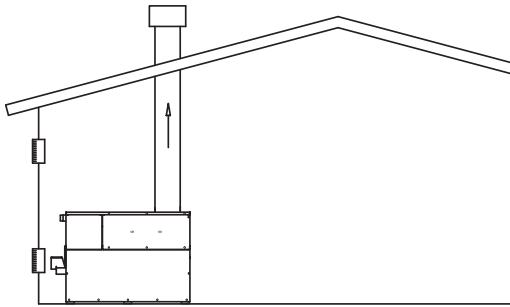

Figure 14 - Conventional Negative Draft Vertical Venting with Combustion Air Louvers

This option uses Type-B double-wall flue outlet piping. The blower brings in combustion air. The buoyancy of the heated flue products cause them to rise up through the flue pipe. The flue outlet terminates at the rooftop.

Negative Draft

The negative draft in a conventional vent installation must be within the range of 0.02 to 0.08 inches w.c. to ensure proper operation. Make all draft readings while the unit is in stable operation (approximately 2 to 5 minutes).

Connect the flue vent directly to the flue outlet opening on the top of the unit. No additional draft diverter or barometric damper is needed on single unit installations with a dedicated stack and a negative draft within the specified range of 0.02 to 0.08 inches w.c. If the draft in a dedicated stack for a single unit installation exceeds the maximum specified draft, you must install a barometric damper to control draft. Multiple unit installations with combined venting or common venting with other Category I negative draft appliances require each boiler to have a barometric damper installed to regulate draft within the proper range.

Do not connect vent connectors serving appliances vented by natural draft (negative draft) to any portion of a mechanical draft system operating under positive pressure. Connecting to a positive pressure stack may cause flue products to be discharged into the living space causing serious health injury.

Flue Outlet Piping

With this venting option, you must use Type-B double-wall (or equivalent) vent materials. Vent materials must be listed by a nationally-recognized test agency for use as vent materials. Make the connections from the unit vent to the outside stack as direct as possible with no reduction in diameter. Use the National Fuel Gas Code venting tables for double-wall vent to properly size all vent connectors and stacks. Follow the vent manufacturer's instructions when installing Type-B vents and accessories, such as firestop spacers, vent connectors, thimbles, caps, etc.

Provide adequate clearance to combustibles for the vent connector and firestop.

When planning the venting system, avoid possible contact with plumbing or electrical wiring inside walls, ceilings, and floors. Locate the unit as close as possible to a chimney or gas vent.

Avoid long horizontal runs of the vent pipe, 90° elbows, reductions and restrictions.

No additional draft diverter or barometric damper is required on single unit installations with a dedicated stack and a negative draft maintained between 0.02 to 0.08 inches w.c.

Common Venting Systems

You can combine the flue with the vent from any other negative draft, Category I appliance. Using common venting for multiple negative draft appliances requires you to install a barometric damper with each unit. This will regulate draft within the proper range. You must size the common vent and connectors from multiple units per the venting tables for Type-B double-wall vents in the latest edition of the National Fuel Gas Code, ANSI Z223.1 and/or CAN/CGA-B149 Installation Code.

Common venting systems may be too large when an existing unit is removed.

At the time of removal of an existing appliance, the following steps shall be followed with each appliance remaining connected to the common venting system placed in operation, while other appliances remaining connected to the common venting system are not in operation.

1. Seal any unused opening in the common venting system.
2. Visually inspect the venting system for proper size and horizontal pitch. Make sure there is no blockage or restriction, leakage, corrosion and other unsafe conditions.
3. If possible, close all building doors and windows. Close all doors between the space in which the appliances remaining connected to the common venting system are located and other building spaces.

Hydronic Heating Boilers and Domestic Water Heaters

INSTALLATION

Continued

4. Turn on clothes dryers and any other appliances not connected to the common venting system. Turn on any exhaust fans, such as range hoods and bathroom exhausts, so they will operate at maximum speed. Do not operate a summer exhaust fan.
5. Close fire place dampers.
6. Place in operation the unit being inspected. Follow the lighting instructions. Adjust thermostat so unit will operate continuously.
7. Test for spillage at the draft hood/relief opening after 5 minutes of main burner operation. Use the flame of a match or candle, or smoke from a cigarette, cigar or pipe.
8. After making sure that each appliance remaining connected to the common venting system properly vents when tested as above, return doors, windows, exhaust fans, fireplace dampers and other gas burning appliances to their previous conditions of use.
9. Correct any improper operation of the common venting system so that the installation conforms to the latest edition of the National Fuel Gas Code, ANSI Z223.1, in Canada, the latest edition of CAN/CGA-B149 Installation Code for Gas Burning Appliances and Equipment. When resizing any portion of the common venting system, resize to approach the minimum size as determined using the appropriate tables of the latest edition of the National Fuel Gas Code, ANSI Z223.1, in Canada, the latest edition of CAN/CGA-B149 Installation Code for Gas Burning Appliances and Equipment.

Masonry Chimney Installations

A masonry chimney must be properly sized for the installation of a high efficiency gas-fired appliance. Venting of a high efficiency appliance into a cold or oversized masonry chimney can result in operational and safety problems. Exterior masonry chimneys, with one or more sides exposed to cold outdoor temperatures, are more likely to have venting problems. The temperature of the flue products from a high efficiency appliance may not be able to sufficiently heat the masonry structure of the chimney to generate proper draft. This will result in condensing of flue products, damage to the masonry flue/tile, insufficient draft and possible spillage of flue products into an occupied living space. Carefully inspect all chimney systems before installation.

Inspection of a Masonry Chimney

A masonry chimney must be carefully inspected to determine its suitability for the venting of flue products. A clay-tile-lined chimney must be structurally sound, straight and free of misaligned tile, gaps between liner sections, missing sections of liner or any signs of condensate drainage at the breeching or clean out. If there is any doubt about the condition of a masonry chimney, it must be relined with a properly-sized and approved chimney liner system. An unlined masonry chimney must not be used to vent flue products from this high-efficiency unit. **An unlined chimney must be relined with an approved chimney liner system when a new appliance is being attached to it.** Metallic liner systems (Type-B double-wall or flexible or rigid metallic liners) are recommended. Consult with local code officials to determine code requirements or the advisability of using or relining a masonry chimney.

Vertical Vent Termination Clearances and Location

Follow all vertical venting termination information for clearances and location under *Vertical Vent Termination Clearances and Location*, page 10.

2. Outdoor Installation Venting

IMPORTANT: Before installing a venting system, follow all venting clearances and requirements found in the *Venting, General Information* section, page 10.

Units are self-venting and can be used outdoors when installed with the optional outdoor caps. These caps mount directly to the unit and cover the flue outlet and combustion air inlet openings. No additional vent piping is required.

⚠ WARNING: Only install outdoor models outdoors and only use the vent caps supplied by the appliance manufacturer. Personal injury or product damage may result if any other cap is used or if an outdoor model is used indoors. Properly install all covers, doors and jacket panels to ensure proper operation and prevent a hazardous condition.

Combustion air supply must be free of contaminants (see *Combustion and Ventilation Air*, page 8). To prevent recirculation of the flue products into the combustion air inlet, follow all instructions in this section.

Installation and Service Manual

Outdoor Vent/Air Inlet Location

Keep venting areas free of obstructions. Keep area clean and free of combustible and flammable materials. Maintain a minimum clearance of 3" (76mm) to combustible surfaces and a minimum of 3" (76mm) clearance to the air inlet. To avoid a blocked air inlet or blocked flue condition, keep the air inlet, flue outlet and drain slot clear of snow, ice, leaves, debris, etc.

Do not install outdoor models directly on the ground. You must install the outdoor unit on a concrete, brick, block, or other non-combustible pad.

Do not locate unit so that high winds can deflect off of adjacent walls, buildings or shrubbery causing recirculation. Recirculation of flue products may cause operational problems, bad combustion or damage to controls. Locate unit at least 3 feet (0.91m) from any wall or vertical surface to prevent wind conditions from affecting performance.

Multiple outdoor unit installations require 48" (1.22m) clearance between each vent cap. Locate the outdoor cap at least 48" (1.22m) below and 48" (1.22m) horizontally from any window, door, walkway or gravity air intake.

Locate the unit at least 10 feet (3.05m) away from any forced air inlet.

Locate the unit at least 3 feet (0.91m) outside any overhang.

Clearances around outdoor installations can change with time. Do not allow the growth of trees, shrubs or other plants to obstruct the proper operation of the outdoor vent system.

Do not install in locations where rain from building runoff drains will spill onto the unit.

Flue gas condensate can freeze on exterior walls or on the vent cap. Frozen condensate on the vent cap can result in a blocked flue condition. Some discoloration to exterior building or unit surfaces can be expected. Adjacent brick or masonry surfaces should be protected with a rust resistant sheet metal plate.

The Outdoor Vent Kit

The optional outdoor vent kit is available from the appliance manufacturer. The outdoor kit part numbers are listed by unit size. See TABLE-D for kit numbers.

You can install the outdoor vent cap and combustion air inlet panel(s) on the unit (see Figures 15 and 16).

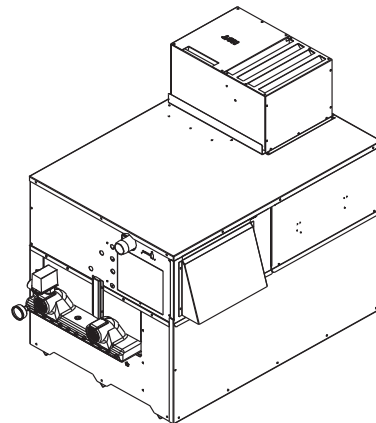

Figure 15 - Outdoor Vent Cap Installed on 495,000 - 1,435,000 Btu/hr Models

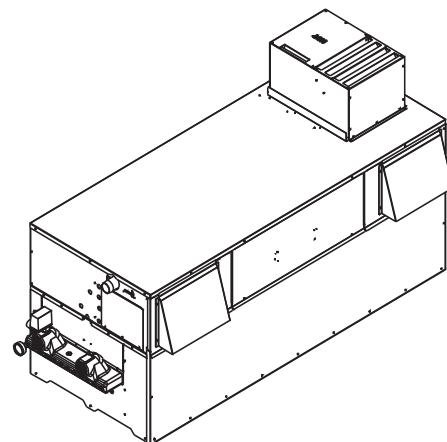

Figure 16 - Outdoor Vent Cap Installed on 1,795,000 and 2,065,000 Btu/hr Models

**TABLE - D
Outdoor Vent Kits**

Input Btu/hr	Kit* w/ Pump Cover	Kit* without Pump Cover
495,000	ODK3023	ODK3014
645,000	ODK3024	ODK3015
745,000	ODK3024	ODK3015
985,000	ODK3046	ODK3043
1,255,000	ODK3047	ODK3044
1,435,000	ODK3047	ODK3044
1,795,000	ODK3048	ODK3045
2,065,000	ODK3048	ODK3045

* These kits include an outdoor vent cap, air inlet hood(s), and gasket.

Hydronic Heating Boilers and Domestic Water Heaters

INSTALLATION

Continued

CONNECTING TO GAS SUPPLY

Only supply the gas type specified on the unit's rating plate. This unit is orificed for operation up to 2000 feet altitude. If installing above 2000 feet elevation, consult the appliance manufacturer.

INLET PRESSURE: Measure inlet pressure at the inlet pressure tap located upstream of the combination gas valve(s). See TABLE-E for maximum and minimum inlet pressures. Do not exceed the maximum. Minimum inlet pressure is for the purposes of input adjustment.

TABLE - E Inlet Pressure		
Input	Max.	Min.
495,000 - 745,000 Btu/hr		
Nat. Gas	10.5" w.c.	4" w.c.
LP Gas	13" w.c.	8" w.c.
985,000 - 2,065,000 Btu/hr		
Nat. Gas	10.5" w.c.	4.5" w.c.
LP Gas	13" w.c.	8" w.c.

MANIFOLD PRESSURE: Measure manifold pressure at the pressure tap on the downstream side of the combination gas valves. The gas regulator on the unit's combination gas valve is adjustable to supply proper manifold pressure for normal operation. See TABLE-I for net manifold pressure settings.

If you must adjust regulator pressure, follow the instructions under *Gas Manifold Pressure Adjustment*, page 19. Do not increase regulator pressure beyond the specified pressure setting.

Gas Pressure Test

1. Disconnect the unit from the gas supply piping system during any piping system pressure testing greater than 1/2 PSIG (3.5kPa).
2. Isolate the unit from the gas supply piping system by closing a manual shutoff valve during any piping system pressure testing that is equal to or less than 1/2 PSIG (3.5kPa).
3. Test all gas connections for gas leaks before placing unit in operation.

Gas Piping

To safely operate this unit, you must properly size the gas supply piping. See TABLES- F, G, & H for piping and fitting requirements. Gas pipe size may be larger than heater connection.

The gas connection for models 495,000 to 745,000 Btu/hr is 1 1/4" NPT and on models 985,000 to 2,065,000 Btu/hr the gas connection to these units is 2" NPT.

For ease of service, install a union.

Install a manual main gas shutoff valve, outside of the unit gas connection within six feet of the unit in accordance with the requirements of the National Fuel Gas Code, ANSI Z223.1.

You must provide a sediment trap (drip leg) in the inlet of the gas connection to the unit.

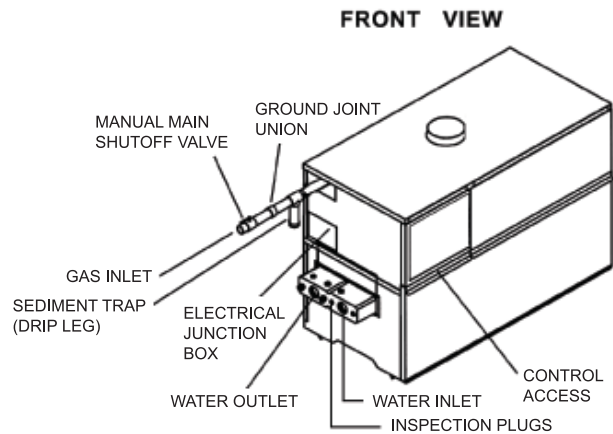

Figure 17 - 495,000 - 745,000 Btu/hr Gas Line Connection Example

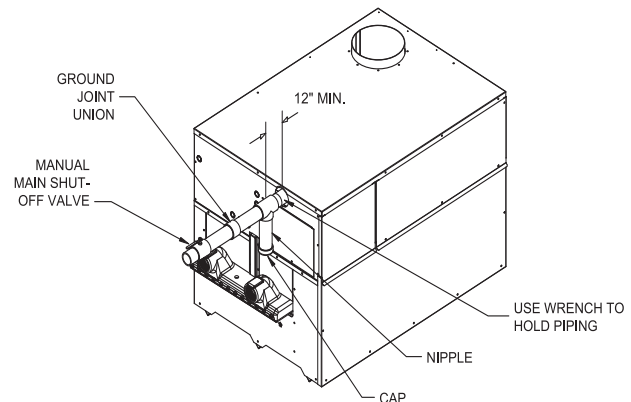

Figure 18 - 985,000 - 2,065,000 Btu/hr Gas Line Connection Example

IMPORTANT: Do not block access to the electrical cover plate when installing the sediment trap. The sediment trap must be a minimum of 12 inches from the appliance.

Installation and Service Manual

The combination gas valves have an integral vent limiting device and does not require venting to atmosphere outside the building. The unit will not operate properly if the reference hose is removed or a vent to atmosphere is installed.

Optional gas controls may require routing of bleeds and vents to the atmosphere outside the building when required by local codes.

Connecting Gas Piping to Unit

All gas connections must be made with pipe joint compound resistant to the action of liquefied petroleum (L.P.) and natural gases. All piping must comply with local codes and ordinances. Piping installations must comply with approved standards and practices.

1. Make sure gas line is a separate line direct from the meter unless the existing gas line is of sufficient capacity. Verify pipe size with your gas supplier.
2. Use new, properly threaded black iron pipe free from chips. If you use tubing, make sure the ends are square, deburred and clean. Make all tubing bends smooth and without deformation. Avoid flexible gas connections. Internal diameter of flexible lines may not provide unit with proper volume of gas.
3. Install a manual main gas shutoff valve at the unit's gas inlet, outside of the unit.
4. Run pipe or tubing to the unit's gas inlet. If you use tubing, obtain a tube to pipe coupling to connect the tubing to the unit's gas inlet.
5. Install a sediment trap in the supply line to the unit's gas inlet (see Figure 17).
6. Apply a moderate amount of good quality pipe compound (do not use Teflon tape) to pipe only, leaving two end threads bare.
7. Remove seal over gas inlet to unit.
8. Connect gas pipe to inlet of unit. Use wrench to support gas manifold on the unit.
9. For L.P. gas, consult your L.P. gas supplier for expert installation.
10. Ensure that all air is properly bled from the gas line before starting the ignition sequence. Start up without properly bleeding air from the gas line may require multiple reset functions of the ignition control module to achieve proper ignition.

⚠ WARNING: Do not have any open flame in proximity to the gas line when bleeding air from the gas line. Gas may be present.

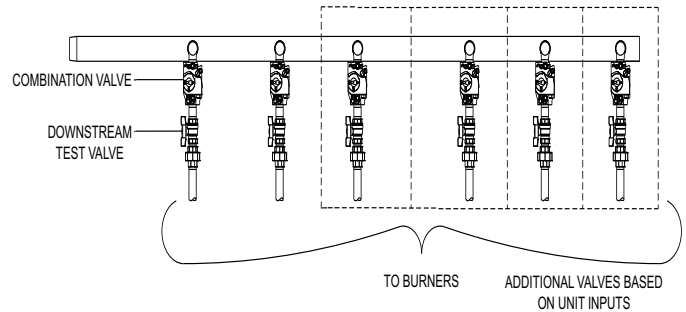

Figure 19 - Gas Train Drawing

TABLE-F Suggested Gas Pipe Size for Single Unit Installations					
Btu/hr Input	Distance From Meter (in feet)				
	0-50	51-100	101-200	201-300	301-500
495,000	1 1/4"	1 1/4"	1 1/2"	2"	2"
645,000	1 1/4"	1 1/2"	2"	2"	2 1/2"
745,000	1 1/2"	2"	2"	2 1/2"	2 1/2"
985,000	2"	2"	2 1/2"	2 1/2"	3"
1,255,000	2"	2 1/2"	2 1/2"	3"	3"
1,435,000	2 1/2"	2 1/2"	3"	3"	3 1/2"
1,795,000	2 1/2"	3"	3"	3 1/2"	3 1/2"
2,065,000	2 1/2"	3"	3"	3 1/2"	4"

For each elbow or tee, add equivalent straight pipe to total length from table below.

Gas Train and Controls

Note: The gas train and controls assembly provided on this unit have been tested under the applicable American National Standard to meet minimum safety and performance criteria such as safe lighting, combustion and safety shutdown operation.

Figure 19 shows a typical gas train.

TABLE-G Fittings to Equivalent Straight Pipe							
Diameter Pipe (inches)							
3/4	1	1 1/4	1 1/2	2	3	4	5
Equivalent Length of Straight Pipe (feet)							
2	2	3	4	5	10	14	20

Hydronic Heating Boilers and Domestic Water Heaters

INSTALLATION

Continued

Water heater models do not have downstream test valves, but the rest of the gas train is represented by Figure 19.

Combination Gas Valves

These units fire in up to 2 stages of burner input. Each stage of burner operation has a combination gas valve or series of gas valves to cycle the gas supply on and off and regulate gas to the burners. Each combination valve consists of a gas regulator and two valve seats to meet the requirements for redundant gas valves. The valve has a gas control knob that must remain in the open position at all times when the unit is in service. The gas control valve has pressure taps located on the inlet and discharge sides of the valve. Manifold pressure is adjusted using the regulator located on the valve. A manifold gas pressure tap for each burner stage is located on the discharge side of the valve.

The manifold pressure is preset at the factory and adjustment is not usually required. If you must adjust regulator pressure, follow the instructions under *Gas Manifold Pressure Adjustment*, page 19.

Venting of Combination Gas Valves

The combination gas valve/regulator used on all units is equipped with an integral vent limiting orifice per ANSI Z21.78. The vent limiter ensures that the volume of gas emitted from the valve does not exceed the maximum safe leakage rate allowed by agency requirements. Combination gas valve/regulators equipped with integral vent limiters are

not required to have vent or relief lines piped to the outdoors. The termination of the vent limited opening on the combination gas valve/regulator complies with the safety code requirements of CSD-1, CF-190(a) as shipped from the appliance manufacturer without the installation of additional vent lines.

Checking Gas Supply Pressure

Use the following procedure to check gas supply pressure.

1. Turn the main power switch to the "OFF" position.
2. Turn gas valve knobs to the "OFF" position.
3. Shut off gas supply at the field-installed manual gas cock in the gas piping to the unit. If fuel supply is L.P. gas, shut off gas supply at the tank.
4. Remove the 1/8" hex plug, located on "inlet" side of the gas valve. You may also use a tapping on the field-installed main manual gas cock or gas piping. Install a fitting in the inlet pressure tapping suitable to connect to a manometer or magnahelic gauge. Range of scale should be 14" w.c. or greater to check inlet pressure.
5. Turn on gas supply at the manual gas cock, turn on L.P. gas at tank if required.
6. Turn the power switch to the "ON" position.
7. Turn the gas valve knobs to the "ON" position. Set the electronic temperature control or thermostat to call for heat.
8. Observe the gas supply pressure as all burners are firing. Ensure that inlet pressure is within the specified range. See *Connecting To Gas Supply*, page 16 for minimum and maximum gas supply pressures.

Nominal Iron Pipe Size, (Inches)	Length of Pipe In Straight Feet													
	10	20	30	40	50	60	70	80	90	100	125	150	175	200
3/4"	369	256	205	174	155	141	128	121	113	106	95	86	79	74
1"	697	477	384	328	292	267	246	226	210	200	179	164	149	138
1 1/4"	1,400	974	789	677	595	543	502	472	441	410	369	333	308	287
1 1/2"	2,150	1,500	1,210	1,020	923	830	769	707	666	636	564	513	472	441
2"	4,100	2,820	2,260	1,950	1,720	1,560	1,440	1,330	1,250	1,180	1,100	974	871	820
2-1/2"	6,460	4,460	3,610	3,100	2,720	2,460	2,310	2,100	2,000	1,900	1,700	1,540	1,400	1,300
3"	11,200	7,900	6,400	5,400	4,870	4,410	4,000	3,800	3,540	3,300	3,000	2,720	2,500	2,340
4"	23,500	16,100	13,100	11,100	10,000	9,000	8,300	7,690	7,380	6,870	6,150	5,640	5,130	4,720

Maximum capacity of pipe in thousands of BTU's per hour for gas pressures of 14 Inches Water Column (0.5 PSIG) or less and a total system pressure drop of 0.5 Inch Water Column (Based on NAT GAS, 1025 BTU's per Cubic Foot of Gas and 0.60 Specific Gravity).

Installation and Service Manual

- If gas pressure is out of range, contact your gas utility, gas supplier, qualified installer or service agency to determine the necessary steps to provide proper gas pressure to the control.
- If gas supply pressure is within normal range, remove the gas manometer and replace the pressure tap fittings in the gas control as indicated in the following steps.
- Turn the power switch to the "OFF" position.
- Turn gas valve knob to the "OFF" position.
- Shut off gas supply at the manual gas cock in the gas piping to the unit. If fuel supply is L.P. gas, shut off gas supply at the tank.
- Remove the manometer and related fittings from the "inlet" side of the gas valve, replace 1/8" hex plug in the gas valve and tighten.
- Turn on the gas supply at the manual valve, turn on L.P. gas at the tank if required.
- Turn the power switch to the "ON" position.
- Turn the gas valve knob to the "ON" position.
- Set the electronic temperature control or thermostat to call for heat.

⚠ WARNING: After completing any testing on the gas system, leak test all gas connections. Apply a soap/water solution to all gas connections while main burners are operating. Bubbles forming indicate a leak. Repair all leaks at once. Do not operate this unit with a leak in the gas train, valves or related piping.

Check burner performance by cycling the system while you observe burner response. Burners should ignite promptly. Flame pattern should be stable, see *Burner Flames*, page 40. Turn the system off and allow burners to cool, then cycle burners again to ensure proper ignition and flame characteristics.

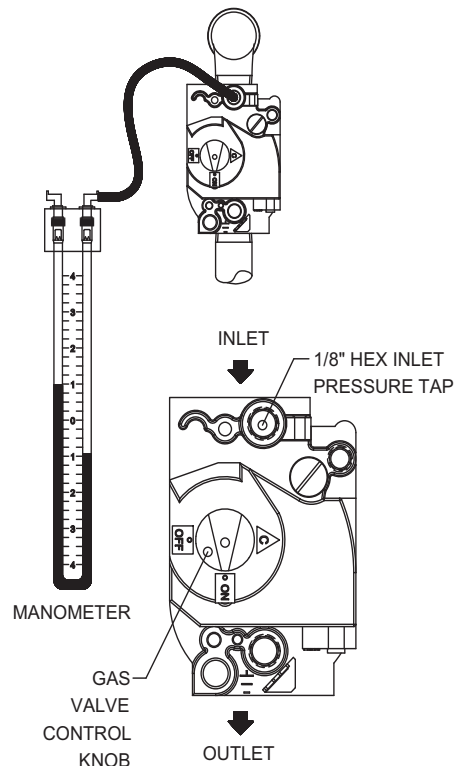

Figure 20 - Measuring Gas Supply Pressure at Combination Gas Valve

Gas Manifold Pressure Adjustment

IMPORTANT: The gas valves are referenced to the fan pressurized chamber by a hose connected from the vent of the gas valve regulator to the chamber pressure tap located on the front inside portion of the jacket. Reference the drawings in this section for component and connection points for pressure measurement. The referenced chamber pressure must be subtracted from the manifold pressure to obtain actual net manifold pressure for normal operation. A manometer or magnahelic gauge legible in 0.1" increments up to 10 inches w.c. is required to check and adjust the manifold pressure. The regulator cover screw on the gas valve must be in place and tight for the unit to operate properly.

- Remove screws that fasten the control panel access door and remove the door.

Hydronic Heating Boilers and Domestic Water Heaters

INSTALLATION

Continued

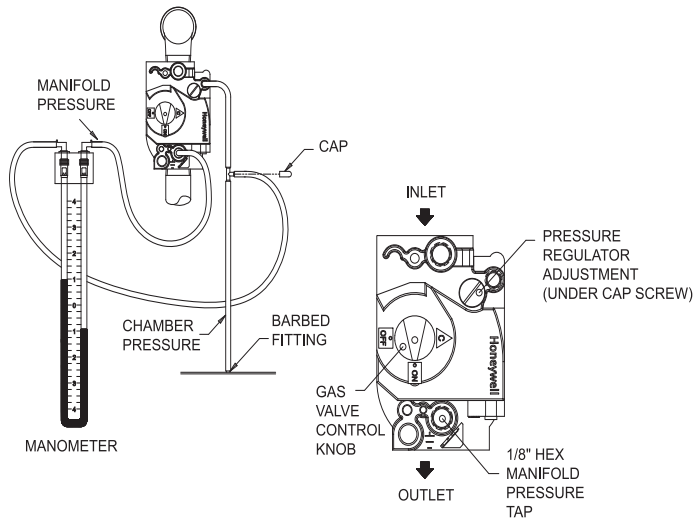

Figure 21 - Measuring Manifold Gas Pressure

2. Turn the power switch located in the lower left corner behind the control panel access door to the “O” or “OFF” position.
3. Remove the top front jacket access panels to access the gas valve(s).
4. Locate the reference hose on the first gas valve which goes from the vent fitting on the gas valve to the barbed fitting on the deck of the unit (see Figure 21).
5. Remove the flexible cap from the barbed fitting on the "tee" located in this line and hook one side of the manometer, or (-) side of a magnahelic gauge, to this "tee". Retain this cap for future use.
6. Remove the 1/8" hex plug from the manifold pressure tap on the gas valve (see Figure 21). Retain plug for future use.
7. Install a fitting in this tap that is suitable for connection of a hose to a manometer, or (+) side of a magnahelic gauge (see Figure 21).
8. Turn the power switch to the “I” or “ON” position.
9. Push the reset button(s) for the ignition control(s), if necessary.
10. Set the temperature control to call for heat (see *Setting Temperature Control*, page 29).
11. Once the unit is firing, the manometer/magnahelic will reflect the net manifold gas pressure. Compare this reading to the respective value in TABLE-I for Natural Gas or Propane Gas.

12. If adjustment is necessary, remove the regulator cover screw on the gas valve. Note: If the gas valve under adjustment is located on a manifold assembly monitored by an igniter, the unit may shut down and recycle when the regulator cover screw is removed. This is normal.
13. Turn the regulator adjustment screw “clockwise” to raise the regulator gas pressure. Turn the regulator adjustment screw “counterclockwise” to lower the regulator gas pressure.
14. Replace the regulator cover screw and make sure it is tight for proper operation.
15. Read the value on the manometer/magnahelic and compare it to the values in TABLE-I.
16. Repeat this adjustment procedure for each gas valve as necessary to adjust to the proper manifold gas pressure.
17. Remove hoses, replace and tighten plugs and caps when complete.
18. Replace top front upper jacket access panels and control panel door in reverse order.
19. If proper ignition and burner operation is not achieved after checking gas supply pressure, see *Cleaning and Maintenance*, page 41 for Combustion Air Fan Adjustment. Follow the procedure to adjust the combustion air fans as necessary.

**TABLE - I
NET MANIFOLD PRESSURE**

**Regulator Pressure Less
Front Chamber Pressure**

Nat. Gas (495,000 - 745,000 Btu/hr)	1.8" w.c.
Nat. Gas (985,000 - 2,065,000 Btu/hr)	1.2" w.c.
LP Gas (495,000 - 2,065,000 Btu/hr)	4.6" w.c.

CONNECTING TO WATER SUPPLY

Inlet and Outlet Connections

For ease of service, install unions on the water inlet and water outlet of the unit. The connection to the unit marked “Inlet” on the header should be used for return from the system. The connection on the header marked “Outlet” is to be connected to the supply side of the system.

Installation and Service Manual

WATER CONNECTIONS
(Models 495 - 745 2" NPT)
(Models 985 - 2065 2 1/2" NPT)

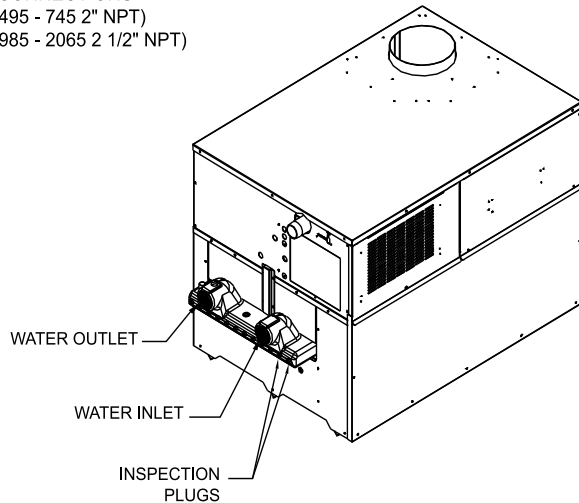

Figure 22 - Water Connections

Relief Valve

This unit is supplied with a relief valve(s) sized in accordance with ASME Boiler and Pressure Vessel Code, Section IV ("Heating Boilers"). The relief valve(s) is installed in the vertical position and mounted in the hot water outlet. Place no other valve between the relief valve and the unit. To prevent water damage, pipe the discharge from the relief valve to a suitable floor drain for disposal when relief occurs. Do not install any reducing couplings or other restrictions in the discharge line. The discharge line will allow complete drainage of the valve and line. Manually operate the relief valves at least once a year.

CAUTION: Avoid contact with hot discharge water.

Water Flow Switch

A water flow switch is factory installed. The flow switch is wired in series with the 24 VAC safety control circuit at the unit's terminal strip. This wiring connection installs the flow switch in the 24 VAC safety circuit to prove water flow before main burner ignition. The factory supplied flow switch is installed in the outlet side of the front header. These units require a minimum flow of 26 GPM to make the flow switch and start burner operation. Ensure that the pump installed on the unit will supply adequate flow to make the flow switch contacts and operate the unit. A water flow switch meets most code requirements for a low water cut off device on appliances requiring forced circulation for operation.

Low Water Cutoff (If Equipped)

If installing this unit above radiation level, you must install a low water cut-off device at the time of appliance installation. Electronic or float type low water cutoff controls are available as a factory supplied option on all units. Inspect the low water cutoff every six months, including flushing of float types. The low water cutoff control is located on the control panel directly behind the control panel cover.

The reset and test buttons (if equipped) are located on the control panel.

CONNECTING TO ELECTRICAL SUPPLY

This unit is wired for 120 VAC service. The unit, when installed, must be electrically grounded in accordance with the requirements of the authority having jurisdiction or in the absence of such requirements, with the latest edition of the National Electrical Code ANSI/NFPA No. 70. When the unit is installed in Canada, it must conform to the CAE C22.1, Canadian Electrical Code, Part 1 and/or local Electrical Codes.

1. Use only Type-T wire [63°F (35°C) rise] on all wiring between the unit and field-installed devices.
2. Enclose line voltage wire exterior to the unit in approved conduit or approved metal-clad cable.
3. The pump must run continuously when the unit is being fired (hot water heating boilers must use the optional pump delay if the pump is to be cycled. See *Freeze Protection*, page 7 when cycling the pump). Water heaters use the pump delay as standard in accordance with ASHRAE 90.1 requirements.
4. To avoid serious damage, do not energize the unit until the system is filled with water.
5. Provide the unit with proper overload protection.

Hydronic Heating Boilers and Domestic Water Heaters

INSTALLATION

Continued

TABLE - J
Nominal AMP Draw Data

Btu/Hr Input	Controls	Fan	Approximate Total Amps
495,000	4.6	3.4	8.0
645,000	4.6	3.4	8.0
745,000	4.6	3.4	8.0
985,000	4.6	3.4	8.0
1,255,000	4.6	3.4	8.0
1,435,000	4.6	3.8	8.4
1,795,000	4.6	3.8	8.4
2,065,000	4.6	3.8	8.4

IMPORTANT: Do not block access to the electrical cover plate when installing electrical conduit.

External EMS Connection to Terminal Strip for Stage Firing Control of Burners

This unit is equipped with a factory installed terminal strip for connection of an energy management system (EMS) to the burner stages. The EMS terminal strip is located in the unit's junction box. Ensure that all wiring used for connection to this terminal strip is properly sized per the recommendations in TABLE-L. When connecting an EMS to this terminal strip to sequence on each stage of burner operation, the unit's internal thermostat or electronic sequencer should be set as an additional high limit control. This will prevent problems between the set points of the EMS and the boiler's internal controller.

Terminal Strip Connection Options (Models 985,000 - 2,065,000 Btu/hr Only)

Figure 24A shows the position of jumpers as shipped from the factory for stand-alone operation of boilers or water heaters.

Figure 24B shows connections to the terminal strip for Remote ON/OFF control of the boiler or water heater. The 1C-1NO jumper must be removed when making these wiring connections. This remote ON/OFF control will provide an Enable/Disable signal to the unit and allow the unit to operate based on the stage set points, until the remote ON/OFF signal is cancelled.

Figure 24C shows the connections necessary to operate the unit as a two-stage (High/Low Fire) boiler or water heater from an Energy Management System (EMS). The actual set point temperatures are controlled by the EMS. The High Fire Offset on the electronic temperature control in the unit must be set to zero and the set point must be set to a value which will function as an upper limit for proper operation under this two-stage control from an EMS.

Figure 24D shows the Continuous and Intermittent terminals. External safety devices connected to these terminals will function to protect the unit. Devices connected to the Intermittent terminals (B1 and B2) are monitored only when there is an active Call for Heat. Devices connected to the Continuous terminals (A1 and A2) are monitored continuously and will activate an alarm (if the unit is equipped with the alarm option) anytime the safety device senses an abnormal condition. An additional wire may be field-installed from these safety devices to terminals A3 or B3 (as appropriate) to activate an alarm (if the unit is equipped with the alarm option).

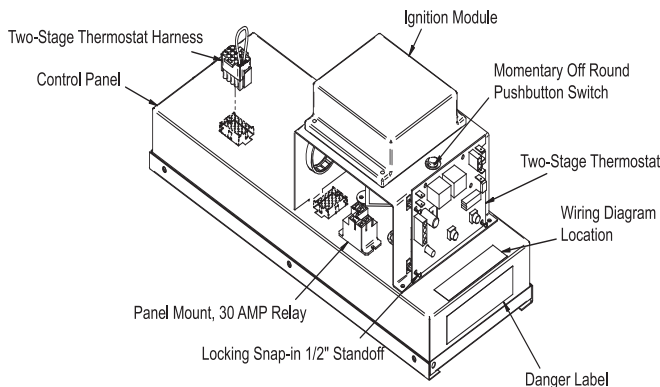

Figure 23A - Models 495,000 - 745,000 Btu/hr Control Panel Component Location Drawing

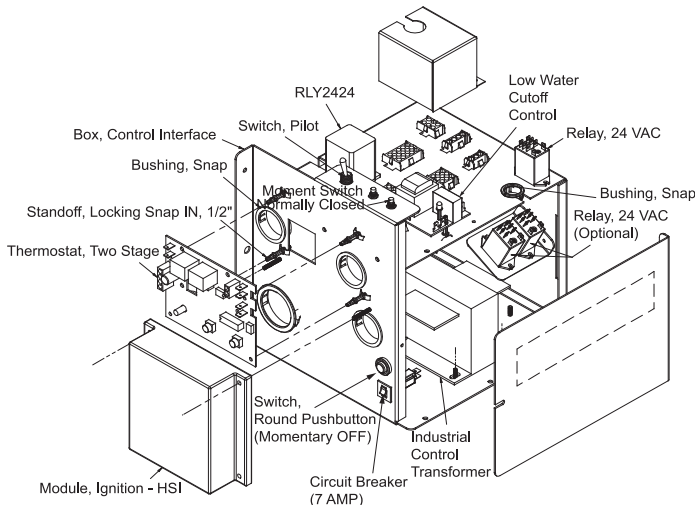

Figure 23B - Models 985,000 - 2,065,000 Btu/hr Control Panel Component Location Drawing

Installation and Service Manual

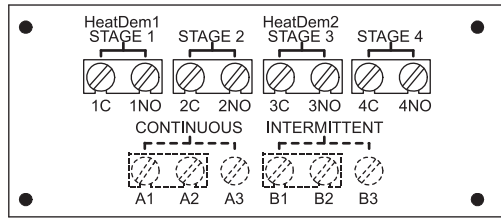

Figure 24A - Stand Alone Operation - Models 985,000 - 2,065,000 Btu/hr Only

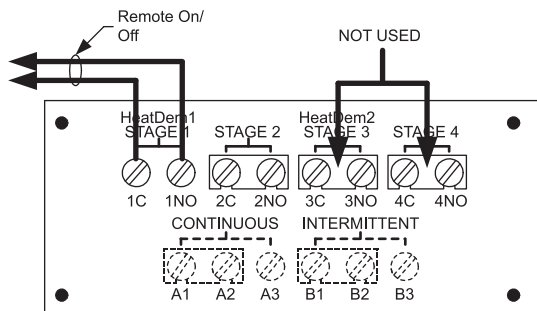

Figure 24B - Remote On/Off Boiler or Water Heater - Models 985,000 - 2,065,000 Btu/hr Only

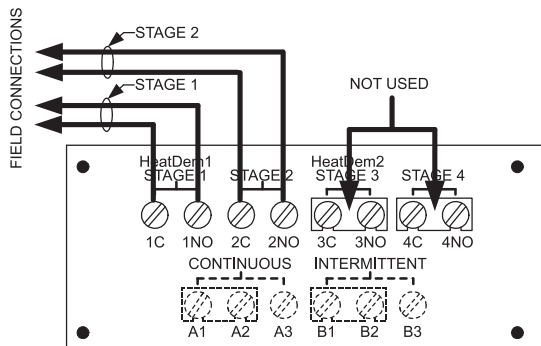

Figure 24C - Two-Stage (High/Low Fire) Boiler or Water Heater - Models 985,000 - 2,065,000 Btu/hr Only

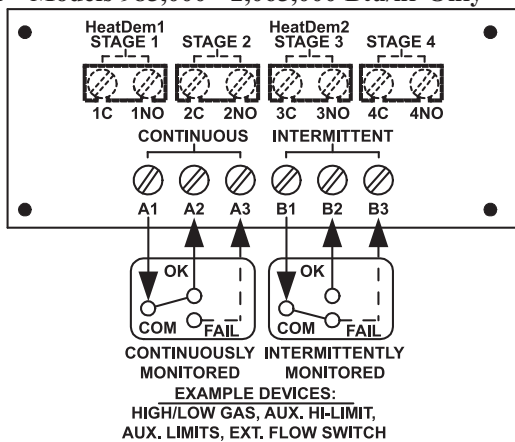

Figure 24D - Field-Installed Safety Devices - Models 985,000 - 2,065,000 Btu/hr Only

BOILER SYSTEM PIPING

The drawings in this section show typical boiler piping installations. Before beginning the installation, consult local codes for specific plumbing requirements. Be sure to provide unions and valves at the boiler inlet and outlet so it can be isolated for service. You must install an air separation device in the installation piping to eliminate trapped air in the system. Locate a system air vent at the highest point in the system. The system must also have a properly sized expansion tank installed. Typically, an air charged diaphragm-type expansion tank is used. You must install the expansion tank close to the boiler and on the suction side of the system pump to ensure proper operation.

CAUTION: This boiler system should not be operated at less than 12 PSIG.

Provide suitable hangers or floor stands to support hot water piping. The boiler alone should not support hot water piping. Copper pipe systems are subject to considerable expansion and contraction. Rigid pipe hangers could allow the pipe to slide in the hanger resulting in noise transmitted into the system. Use padding on rigid hangers installed with a copper system. Pipe the boiler pressure relief valve to a suitable floor drain. See the relief valve section in this manual.

CAUTION: A leak in a boiler "system" will cause the "system" to intake fresh water constantly, which will cause the tubes to accumulate a lime/scale build up. This will cause a non-warrantable failure.

General Plumbing Rules

1. Check all local codes.
2. For serviceability of boiler, always install unions.
3. Always pipe the pressure relief valve to an open drain.
4. Locate system air vents at the highest point of system.
5. Expansion tank must be installed near the boiler and on the suction side of the pump.
6. Support all water piping.

Water Connections: Heating Boilers Only

Inlet and outlet water connections on models 495,000 - 745,000 Btu/hr have 2" NPT and on models 985,000 - 2,065,000 Btu/hr the inlet and outlet connections are 2 1/2" NPT.

Note: Field-installed reducing bushings may decrease flow resulting in boiler noise or flashing to steam.

Hydronic Heating Boilers and Domestic Water Heaters

INSTALLATION

Continued

Circulator Pump Requirements

This is a low mass, high efficiency hot water boiler which must have adequate flow for quiet, efficient operation. Pump selection is critical to achieve proper operation. A pump should be selected to achieve proper system design water temperature rise. Two heat exchanger head-loss charts (Figure 25A & 25B) are provided to assist in proper pump selection. Also provided is a *System Temperature Rise Chart* (TABLE-K). This table provides GPM and boiler head-loss at various temperature rises for each boiler based on Btu/hr input. Temperature rise is the difference in boiler inlet temperature and boiler outlet temperature while the boiler is firing.

Example: The boiler inlet temperature is 160°F (71°C) and the boiler outlet temperature is 180°F (82°C), this means that there is a 20°F (11°C) temperature rise across the boiler.

Heat Exchanger Pressure Drop Chart

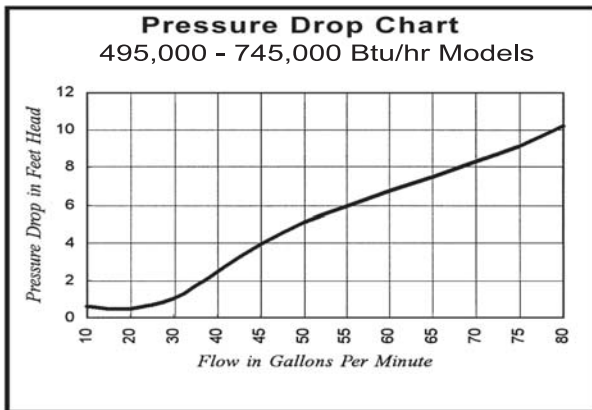

Figure 25A - Pressure Drop Chart_Models 495,000 - 745,000 Btu/hr

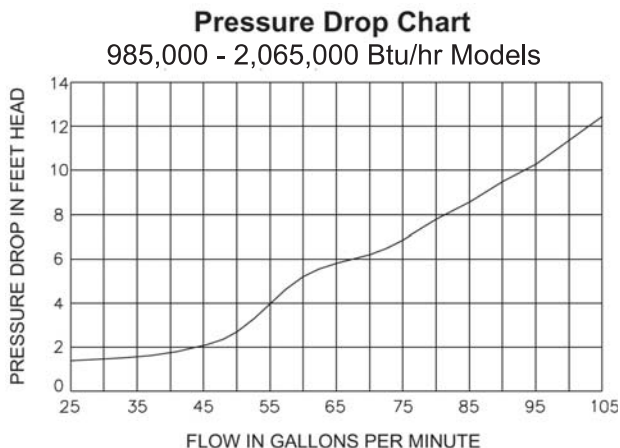

Figure 25B - Pressure Drop Chart_Models 985,000 - 2,065,000 Btu/hr

Circulator Pump Specifications

1. Maximum operating pressure for pump must exceed system operating pressure.
2. Maximum water temperature should not exceed nameplate rating.
3. Cast iron circulators may be used for closed loop systems.
4. A properly sized expansion tank must be installed near the boiler and on the suction side of the pump.

Circulator Pump Operation (Heating Boilers Only)

The boiler pump should run continuously unless the boiler is provided with the optional pump delay control system. This optional pump control system is available as a factory-installed option. External wire leads are furnished with this option to allow the power supply for the pump to be switched across the normally open contacts of the relay, allowing the control relay to cycle the pump on each call for heat. The field installed boiler pump (using the optional factory supplied pump control system) must not exceed 10 AMPS at 120VAC. As shipped from the factory, the optional control system is set to cycle the boiler pump on at each call for heat before the burners fire and run the pump for a 30 second period after the thermostat is satisfied. This will remove any residual heat from the combustion chamber before turning the pump off. See *Wiring Diagrams*, page 47.

Pump Installation and Maintenance

For installation and maintenance information on the circulator pump, refer to pump manufacturers instructions included in the instruction package.

Primary/Secondary Boiler Piping

Boiler installations with a primary/secondary piping system as shown in Figure 26 are recommended. This type of system uses a dedicated pump to supply flow to the boiler only. This secondary pump is sized based on desired boiler flow rate, boiler head loss and head loss in the secondary system piping only. A properly-sized system pump provides adequate flow to carry the heated boiler water to radiation, air over coils, etc. The points of connection to the primary system should be a maximum of 12" (or 4 pipe diameters) apart to ensure connection at a point of zero pressure drop in the primary system. Multiple boilers may also be installed with a primary/secondary manifold system as shown in Figure 27. The multiple boilers are connected to the manifold in reverse return to assist in balancing flow to multiple boilers.

CAUTION: DO NOT allow the flow in the primary loop to drop lower than the flow in the secondary loop at any time during boiler operation. Improper operation of the boiler(s) and possible tripping of the high limits and relief valves may occur.

Installation and Service Manual

The installer must ensure that the boiler has adequate flow without excessive temperature rise. Low system flow can result in overheating of the boiler water which can cause short burner ON cycles, system noise and in extreme cases, a knocking flash to steam. These conditions indicate the need to increase boiler flow by installation of a larger circulator pump or the installation of a system bypass. System noise may also indicate an oversized boiler.

⚠ CAUTION: At no time should the system pressure be less than 12 PSIG.

temperature protection valve (LTV) that is factory preset to maintain 140°F inlet water to the boiler regardless of the system return water temperature. See Table K for available valve kits.

Table - K LTV Valve Kits	
Input Btu/hr	LTV Valve Kit
495,000 - 745,000	VAL3048
985,000 - 2,065,000	VAL3047

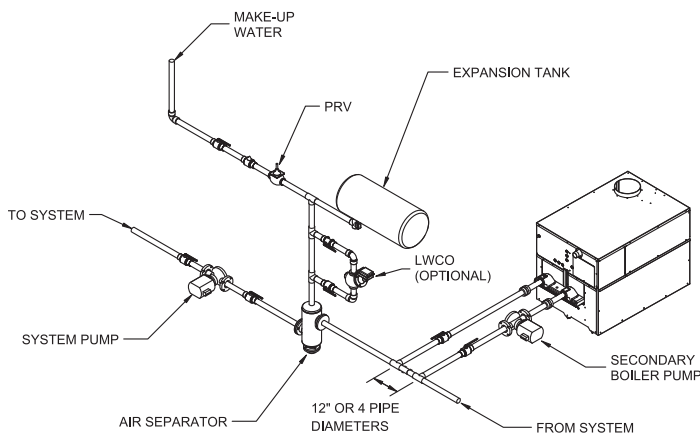

Figure 26 - Primary/Secondary Piping of a Single Boiler

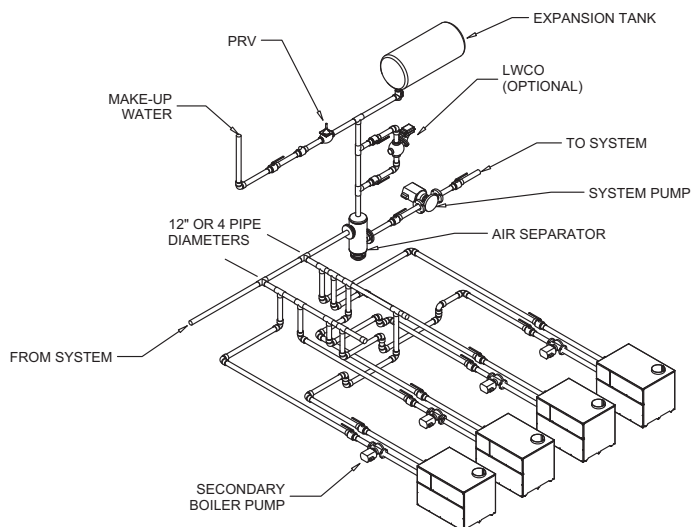

Figure 27 - Primary/Secondary Piping of Multiple Boilers

Low Temperature Return Water Systems

Any non-condensing boiler and venting system will develop operational problems when exposed to inlet water temperatures below 140°F. Lochinvar offers a low

Be sure to install the LTV valve per the piping diagrams included with the kits. Alternatively, a bypass as shown in FIG. 28 may be piped into the system. This piping is like a primary/secondary boiler installation with a bypass in the secondary boiler piping. Inlet water temperatures below 140°F (60°C) can excessively cool the products of combustion resulting in condensation on the heat exchanger and in the flue. Condensation can cause operational problems, bad combustion, sooting, flue gas spillage and reduced service life of the vent system and related components. The bypass allows part of the boiler discharge water to be mixed with the cooler boiler return water to increase the boiler inlet temperature above 140°F (60°C). This should prevent the products of combustion from condensing in most installations. The bypass should be fully sized with a balancing valve to allow for proper adjustment. A valve must also be provided on the boiler discharge, after the bypass. Closing this discharge valve forces water through the bypass. Start boiler adjustment with the bypass valve in the full open position and the boiler discharge valve half open. A small amount of the higher temperature boiler discharge water is mixed with the system water to maintain the desired lower system temperature. A remote low temperature range operator is recommended to control the boiler operation based on the lower system temperature. (See *Terminal Strip Connection Options* starting on page 22).

Radiant Floor and Snow Melt Heating Systems

This type of heating boiler application operates in a low temperature range which requires a boiler bypass as described under Low Temperature Bypass Requirements. A non-metallic rubber or plastic tubing installed in a radiant (in floor) system must have an oxygen barrier to prevent oxygen from entering the system through the walls of the installed tubing. Excessive oxygen absorption into the system will result in an accelerated rate of corrosion causing a sludge buildup. This excessive corrosion will also damage the boiler and system components.

Hydronic Heating Boilers and Domestic Water Heaters

INSTALLATION

Continued

Sludge formed as the result of excessive oxygen in the system can restrict water flow resulting in a premature boiler failure. Any boiler damage due to excessive oxygenation is non-warrantable.

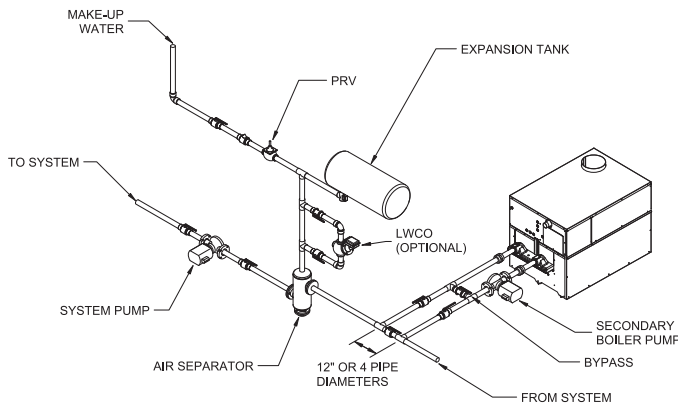

Figure 28 - Boiler with Low Temperature Bypass Piping

Installation with a Chilled Water System

Pipe refrigeration systems in parallel. Install duct coil downstream at cooling coil. Where the hot water heating boiler is connected to a heating coil located in the air handling units which may be exposed to refrigeration air circulation, the boiler piping system must be equipped with flow control valves or other automatic means to prevent gravity circulation of the boiler water during the cooling cycle. The coil must be vented at the high point and hot water from the boiler must enter the coil at this point. Due to the fast heating capacity of the boiler, it is not necessary to provide a ductstat to delay circulator operation. Also, omit thermostat flow checks as the boiler is cold when heating thermostat is satisfied. This provides greater economy over maintaining standby heat (see Figure 29).

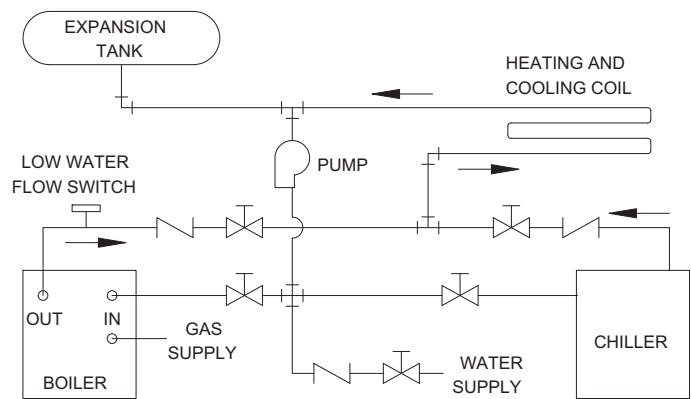

Figure 29 - Installation with a Chilled Water System

TABLE - L
System Temperature Rise Chart Based on Btu/hr Input

Input	Output	ΔT 10°F		ΔT 20°F		ΔT 30°F		ΔT 40°F		ΔT 50°F		ΔT 60°F	
		GPM	FT.HD	GPM	FT.HD	GPM	FT.HD	GPM	FT.HD	GPM	FT.HD	GPM	FT.HD
495,000	400,950	80+	*	40	4.0	27	1.6	20	0.7	16	0.6	13	0.6
645,000	522,450	129+	*	52	5.1	35	3.0	26	1.6	21	0.8	17	0.6
745,000	603,450	149+	*	60	*	40	4.0	30	2.3	24	1.2	20	0.7
985,000	831,600	197+	*	80	5.2	53	2.4	40	1.4	32	1.0	27	0.8
1,255,000	1,058,400	251+	*	102+	*	68	4.3	51	2.5	41	1.6	34	1.1
1,435,000	1,209,000	288+	*	116+	*	78	6.0	58	3.7	47	2.2	39	1.7
1,795,000	1,512,000	360+	*	146+	*	97+	*	73	6.2	58	4.2	49	2.4
2,065,000	1,738,800	414+	*	168+	*	112+	*	84	8.7	67	6.0	56	4.5

+ These flow rates exceed recommended flow rates of boiler. If these system temperature rises are used, an external piping by-pass must be installed.
* These foot head calculations exceed the maximum allowable flow rate of the boiler. Requires Cupro-Nickel heat exchanger.

Installation and Service Manual

Boiler Flow Rate

⚠ CAUTION: The maximum flow rate for models 495,000 - 745,000 Btu/hr is 60 GPM and 90 GPM on 985,000 - 2,065,000 models. Do not exceed the maximum flow rate of the heating boiler.

If higher flow rates are required through the boiler, an optional Cupro-Nickel heat exchanger is available. When using a Cupro-Nickel heat exchanger, GPM can be increased by 30 percent. Consult the factory for specific application requirements.

The heat exchanger is generally capable of operating within the design flow rates of the building heating system. Should the flow rate exceed the maximum allowable flow rate through the boiler an external bypass must be installed. The bypass should be fully sized with a balancing valve to allow for proper adjustment of flow. Flow rate can be determined by measuring the temperature rise through the boiler.

Boiler Bypass Requirements

The installer must ensure that the boiler is supplied with adequate flow without excessive temperature rise. It is recommended that this boiler be installed with a bypass in the piping if the maximum recommended flow rate is exceeded. The bypass will help to ensure that the boiler can be supplied with adequate water flow. Flow rates exceeding the maximum recommended flow will result in erosion of the boiler tubes. A typical bypass with a valve is shown in Figure 30 will allow control of boiler flow.

Temperature/Pressure Gauge

This boiler is equipped with a dial type temperature/pressure gauge. This gauge is factory installed in the outlet side of the heat exchanger. The gauge has one scale to read system pressure and a separate scale to read water temperature in degrees, Fahrenheit.

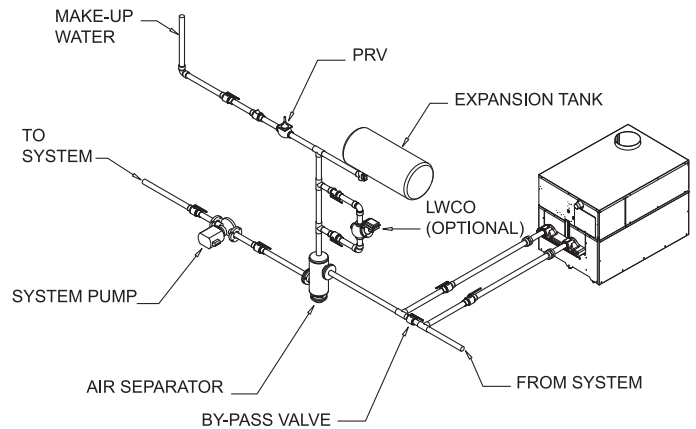

Figure 30 - Boiler Bypass Piping for High Flow Systems

Filling the System

All air must be purged from the system for proper operation. An air scoop and air vent must be located close to the boiler outlet and there should be a minimum distance between the cold water feed and the system purge valve.

1. Close all drain cocks and air vents.
2. Open the makeup water valve and slowly fill the system.
3. If a makeup water pump is employed, adjust the pressure to provide a minimum of 12 psi at the highest point in the system. If a pressure regulator is also installed in the line, it should be adjusted to the same pressure.
4. Close all valves. Purge one circuit at a time as follows:
 - A. Open one circuit drain valve and let the water drain for at least five minutes. Ensure that there are no air bubbles visible in the water stream before closing the drain valve.
 - B. Repeat this procedure for each circuit.
5. Open all valves after all circuits have been purged. Make sure there are no system leaks.

⚠ CAUTION: Do not use petroleum based stop leak products. All system leaks must be repaired. The constant addition of make-up water can cause damage to the boiler heat exchanger due to scale accumulation. Scale reduces flow and heat transfer, causing overheating of the heat exchanger.

6. Run the system circulating pump for a minimum of 30 minutes with the boiler turned off.
7. Open all strainers in the system and check for debris.

Hydronic Heating Boilers and Domestic Water Heaters

INSTALLATION

Continued

8. Recheck all air vents as described in step 4.
9. Inspect the liquid level in the expansion tank. The system must be full and under normal operating pressure to ensure proper water level in the expansion tank. Ensure that diaphragm type expansion tanks are properly charged and not water logged.
10. Start the boiler according to the operating instructions in this manual. Operate the system, including the pump, boiler and radiation units, for one hour.
11. Recheck the water level in the expansion tank. If it exceeds half the tank volume, open the tank to reduce the water level. Recheck pressure charge on diaphragm type tanks.
12. Shut down the entire system and vent all radiation units and high points in the system.
13. Close the water makeup valve and check the strainer and pressure reducing valve for sediment or debris. Reopen the water makeup valve.
14. Verify system pressure with the boiler pressure gauge before beginning regular operation.
15. Within three days of startup, recheck and bleed all air vents and the expansion tank using these instructions.

WATER TREATMENT

In hard water areas, water treatment should be used to reduce the introduction of minerals to the system. Minerals in the water can collect in the heat exchanger tubes and cause noise on operation. Excessive build up of minerals in the heat exchanger can cause a non-warrantable failure.

OPERATION

FOR YOUR SAFETY READ BEFORE OPERATING

⚠ WARNING: If you do not follow these instructions exactly, a fire or explosion may result causing property damage, personal injury or loss of life.

- A. This appliance does not have a pilot. It is equipped with an ignition device which automatically lights the burner. Do not try to light the burner by hand.
- B. **BEFORE OPERATING**, smell around the appliance area for gas. Be sure to smell next to the floor because some gas is heavier than air and will settle to the floor.

WHAT TO DO IF YOU SMELL GAS

- Do not try to light any appliance.
- Do not touch any electric switch; do not use any phone in your building.
- Immediately call your gas supplier from a neighbors phone.
- Follow the gas supplier's instructions.
- If you cannot reach your gas supplier, call the fire department.

- C. Use only your hand to turn the gas control lever. Never use tools. If the lever will not turn by hand, don't try to repair it, call a qualified service technician. Force or attempted repair may result in a fire or explosion.
- D. Do not use this boiler if any part has been under water. Immediately call a qualified service technician to replace the boiler. The possible damage to a flooded boiler can be extensive and present numerous safety hazards. Any appliance that has been under water must be replaced.

Lighting Instructions

1. **STOP!** Read the safety information.
2. Set the temperature control to the desired settings (see *Setting Temperature Control*, page 29).
3. Loosen the knurled knob at the bottom of the control panel cover (see Figure 31).
4. Grasp the bottom of the control panel cover and pull out and down.
5. Locate the ON/OFF switch inside the control area. The switch is located to the left of the control panel (see Figure 32).
6. Turn the power switch to the "OFF" position.
7. This unit is equipped with an ignition device which automatically lights the burners. Do not try to light the burners by hand.

Installation and Service Manual

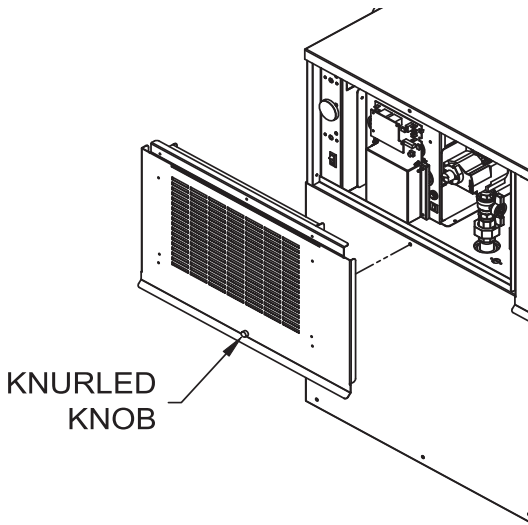

Figure 31 - Control Panel Cover

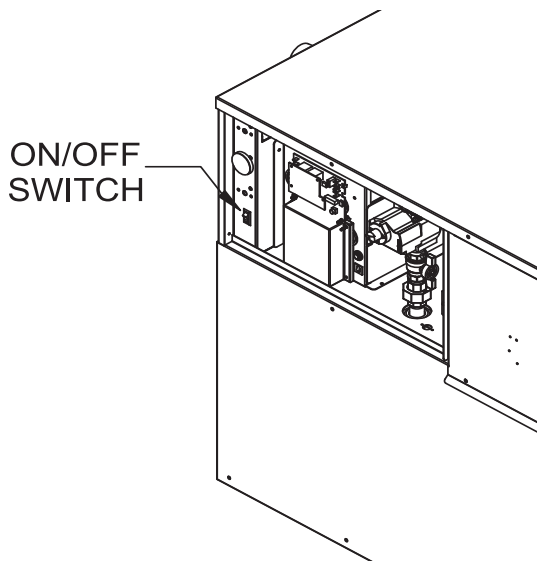

Figure 32 - ON/OFF Switch

- Turn the manual gas cock clockwise to the "OFF" position.
- Wait five (5) minutes to clear out any gas. If you smell gas, STOP! Follow "B" in the safety information. If you do not smell gas, go on to the next step.
- Turn the manual gas cock counterclockwise to the "ON" position.
- Turn the power switch to the "ON" position.
- Reinstall the control panel cover. Tighten the knurled knob at the bottom of the control panel cover.
- If the unit will not operate, follow the instructions "To Turn Off Gas To Appliance" and call your service technician or gas supplier.

To Turn Off Gas To Appliance

- Remove the control panel cover to access control panel.
- Turn power switch to "OFF" position.
- Turn the manual gas cock clockwise to the "OFF" position.

⚠ WARNING: Should overheating occur or the gas fail to shut off, turn off the manual gas control valve to the unit.

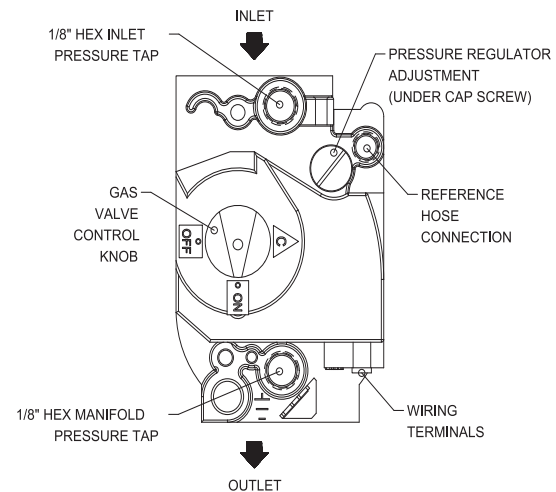

Figure 33 - Combination Gas Valve

SETTING TEMPERATURE CONTROL

Note: The temperature controller is preset at the factory with test settings. You may need to adjust the settings to meet your specific needs.

⚠ WARNING: Return water temperatures must not be less than 140°F. If lower return water temperatures are required, follow the instructions for *Low Temperature Return Water Systems* on page 25.

Locating Temperature Control

The temperature control is located behind the combustion air inlet panel on the left front of the unit (see Figure 34). Follow the steps below to access the temperature control.

- Loosen the knurled knob at the bottom of the control panel cover.
- Pull the bottom of the panel out and down to remove.

Hydronic Heating Boilers and Domestic Water Heaters

OPERATION

Continued

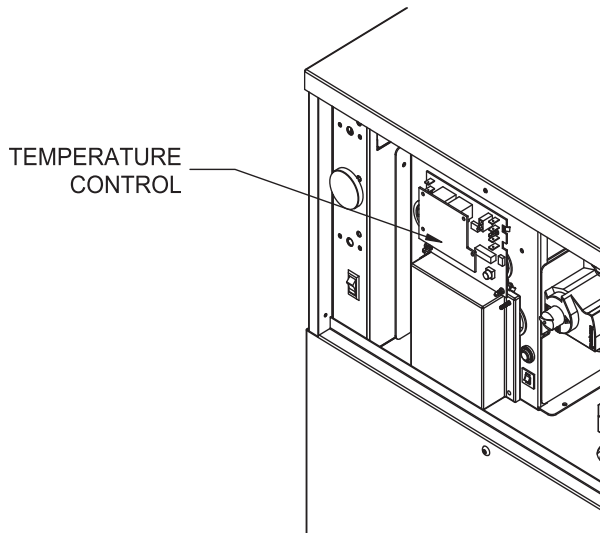

Figure 34 - Locating Temperature Control

Temperature Control Settings

There are three setting knobs on the temperature control unless your unit is specified as a boiler only with an outdoor air reset option. If your unit is a boiler only with an outdoor air reset option, there are additional controls for this option. They are explained under *Outdoor Air Reset Option*, page 31.

The three setting knobs on the temperature control are for Set Point, Differential, and High-Fire Offset (see Figure 35).

Maximum Set Point Determination

The maximum set point for the control is factory set. Boilers are set to 230°F max., water heaters are set to 190°F max., and specialty state and local codes to 200°F.

These maximum set points are established by not cutting/cutting the OJ1 and OJ2 jumpers located on the right side of the temperature controller (see Figure 35). The maximum set point is determined as shown in TABLE-M.

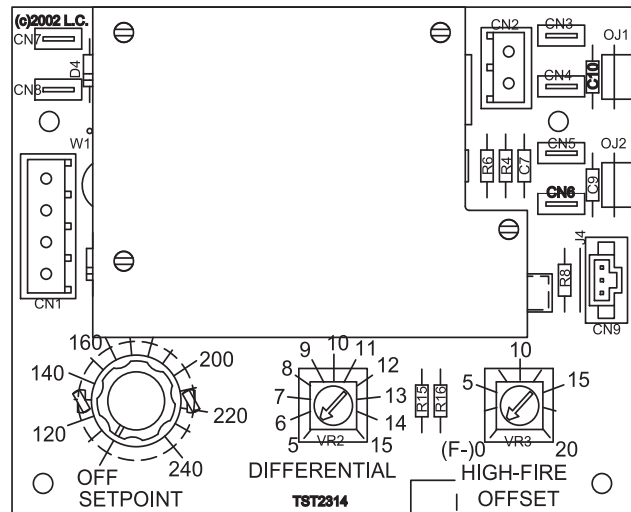

Figure 35 - Temperature Control Setting Knobs

TABLE - M Maximum Set Point Determination		
OJ1	OJ2	Max. Set Point
Connected	Connected	230°F
Cut	Connected	190°F
Connected	Cut	200°F
Cut	Cut	160°F

Note: Anytime that OJ1 is the only jumper cut, a new overlay is required under the Set Point knob on the temperature controller because the scale has changed to a maximum of 190°F.

Anytime the OJ2 jumper is cut (with or without OJ1), a new overlay is required under the Set Point knob on the temperature controller because the scale has changed to a maximum of 200°F.

Set Point

The Set Point knob specifies the target water temperature in degrees, Fahrenheit. After the water temperature reaches the set point, the temperature control shuts off the burners.

Differential

The Differential specifies the number of degrees below the set point that the control will allow the water temperature to drop before it brings the unit back on again.

Installation and Service Manual

High-Fire Offset

The temperature control operates a two-stage firing system. The two stages are High-Fire and Low-Fire. High-Fire operates all burners while Low-Fire operates approximately one-half of the burners.

The High-Fire knob specifies the number of degrees below set point that the High-Fire stage shuts down. At that point, the unit will continue to operate at the Low-Fire stage until the set point is reached.

The High-Fire offset knob has settings between 0°F and 20°F. If set at 0°F, the High-Fire offset is disabled and the unit will operate at the High-Fire stage until the set point is reached and the temperature control shuts the unit off.

When the High-Fire offset knob is set to 0 or 1, the unit will light at Low Fire and operate for approximately 10 seconds before the High-Fire stage actuates. When set to 2 or above, the unit will operate at Low Fire for 2 minutes before the High Fire stage actuates.

Outdoor Air Reset Option

For boilers ordered with the Outdoor Air Reset option, there is an additional control (see Figure 36). There are three setting knobs for Shutdown, Outdoor Air Max., and Ratio. There is also a switch to turn the outdoor air sensor On or Off. An O.A. Sensor is also included.

Shutdown

The Shutdown knob specifies the outdoor air lockout temperature at which the control would prevent the unit from operating. This feature can be enabled/disabled with the O.A. Shutdown switch.

Outdoor Air Max (O.A. Max)

The O. A. Max knob allows a reset up to the maximum outdoor air temperature specified by this knob setting. When the outdoor air temperature is above the specified setting, the unit will not function in the O.A. Reset Mode, but will continue to run at the selected set point temperature.

Note that the set point knob will now indicate the “minimum” boiler temperature. Target temperature is determined by the ratio and outdoor air temperature below the O.A. Max setting.

Ratio

The Ratio knob allows the control over the reset ratio to be used during Outdoor Air Reset. The allowable ratios are as low as 0.5:1 or as high as 1.5:1.

Selecting the 0.5:1 ratio will increase the set point 0.5°F for every 1.0°F drop in outdoor air temperature up to the maximum set point temperature.

Selecting the 1.5:1 ratio will increase the set point 1.5°F for every 1.0°F drop in outdoor air temperature up to the maximum set point temperature.

See Figure 37 for an outdoor air reset chart example.

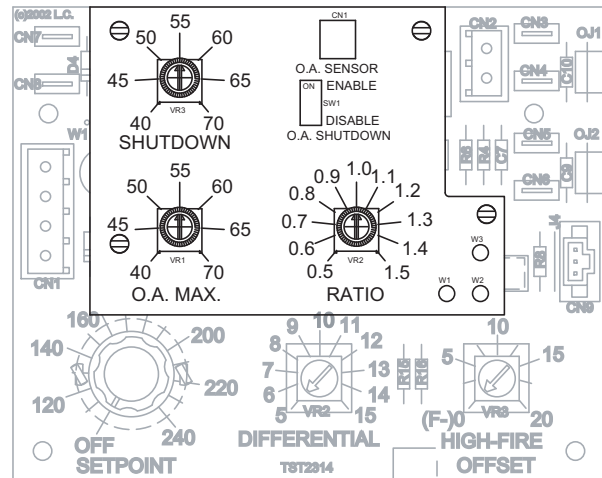

Figure 36 - Optional Outdoor Air Reset Control

Hydronic Heating Boilers and Domestic Water Heaters

OPERATION

Continued

Temperature Control Sensors

This is a two-stage temperature control that controls the burner ignition, pump, and alarm functions. This temperature controller can measure up to three different sensor inputs, depending upon how the unit is set up. They are as follows:

1. Inlet Water Temperature Sensor
2. Multi-Purpose Temperature Sensor
3. Outside Air Temperature Sensor

Inlet Water Temperature Sensor

This sensor measures the inlet water temperature coming into the unit.

Multi-Purpose Temperature Sensor

Depending upon how your unit is set up, this sensor can be used as a system sensor or a tank sensor.

Outdoor Air Temperature Sensor

This sensor is only available on boiler units with an outdoor air reset option. This allows you to tie boiler operation to the outdoor air temperature. As outside temperatures drop, the control will increase the temperature setting of the boiler. As outdoor temperatures rise, the control will decrease the temperature to the selected set point of the boiler. You can set the control to shut the boiler off when a desired outdoor air temperature level is reached.

Boiler Application

Standard boiler units are shipped with two sensors; the inlet water temperature sensor and the multi-purpose temperature sensor. The multi-purpose sensor should be used as a system sensor. Boilers with the outdoor air reset option also have an outside air temperature sensor.

Water Heater Application

Water heater units are shipped with two sensors; the inlet water temperature sensor and the multi-purpose temperature sensor to be used as a tank sensor.

Placement of Sensors

Inlet Temperature Sensor

The inlet water temperature sensor is placed into the inlet bulbwell on the boiler. This sensor is installed by the factory in new units. Make sure to insert the sensor all the way into the bulbwell, leaving no air pocket between the front surface of the sensor and the back of the bulbwell. Air pockets are thermally non-conductive and will cause sensors to not read accurately.

System Sensor

This is used for boiler applications. This sensor will control the boiler operation based upon the water temperature within the building loop.

Tank Sensor

This is used in water heating applications. Place the sensor in the water storage tank to measure water temperature. For more information on mounting the sensor, see *Remote Mounting of Sensors*, page 33.

Outside Air Temperature Sensor

The outside air temperature sensor will only be used for boiler systems. The outside air sensor is optional. You must purchase the sensor from the appliance manufacturer. The sensor comes with a housing that helps protect the sensor from the elements. Mount the air sensor housing under the eave of the roof. Make sure the housing is out of direct sunlight. This will ensure that the sensor will accurately read the true outdoor temperature. For more information on mounting the sensor, see *Remote Mounting of Sensors*, page 33.

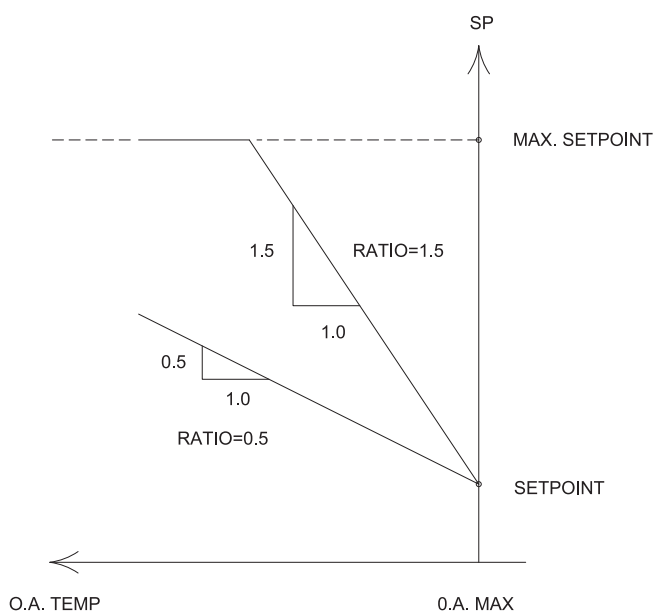

Figure 37 - Outdoor Air Reset Chart Example

Installation and Service Manual

Remote Mounting of Sensor

You must mount the outside air temperature sensor outside the building. To mount remote sensors, follow the guidelines below. Take care to correctly wire sensors to the unit. Erratic temperature readings can be caused by poor wiring practices. Twist the wires between the unit and the remote sensor. Turn wires at least three or four turns per linear foot of wiring. This provides common mode rejection of some types of electrical interferences.

1. Do not route temperature sensor wiring with building power wiring.
2. Do not locate temperature sensor wiring next to control contactors.
3. Do not locate temperature sensor wiring near electric motors.
4. Do not locate temperature sensor wiring near welding equipment.
5. Make sure good mechanical connections are made to the sensor, any interconnecting wiring and the controller.
6. Do not mount sensor with leadwire end pointing up in an area where condensation can occur.
7. Use shielded wiring to connect the sensor to the control when the possibility of an electrically noisy environment exists. Shielded cable is recommended on all cable runs of more than 25 feet in length.

Note: Ground the cable shield at the connection to the boiler temperature control only. Do not ground the shielded cable at the sensor end.

To maintain temperature accuracy, sensor wires should be at least 18 AWG, see Table N below.

TABLE - N Remote Wire Connection	
Wire Gauge	Maximum Allowable Length
12 GA	100 ft
14 GA	75 ft
16 GA	50 ft
18 GA	30 ft

HOT SURFACE IGNITION SYSTEM

Hot Surface Igniter and Ignition Control Module

This unit has one ignition module and one hot surface igniter.

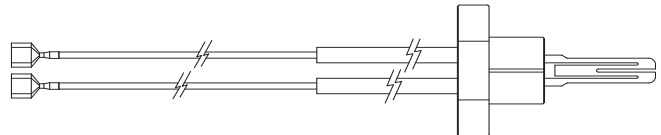

Figure 38 - Hot Surface Igniter

⚠ Caution: The igniter is extremely fragile, be very careful when removing. A faulty or damaged hot surface igniter **MUST BE** replaced with a Lochinvar PLT3400 igniter. Do not use general purpose field replacement igniters.

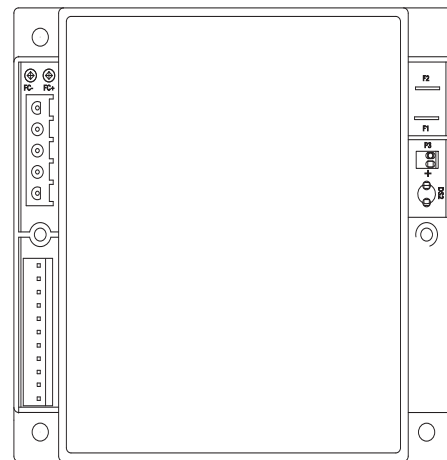

Figure 39 - Hot Surface Ignition Control Module

Hydronic Heating Boilers and Domestic Water Heaters

OPERATION

Continued

Hot Surface Ignition Control Module

Ignition Module Lockout Functions

The ignition module may lockout in either a hard-lockout condition, requiring pushing of the reset button to recycle the control, or a soft-lockout condition which may recycle after an approximate five-minute waiting period. This soft-lockout condition is intended to allow self-correcting faults to correct themselves and permit normal operation. A typical hard-lockout fault is a flame failure condition. An ignition module that is in a hard-lockout condition may only be reset by pushing the reset button next to the ignition control or the "RESET" button on the diagnostic panel on the left end of the unit. Upon a flame failure, the reset button is only active after the control module has completed its post-purge cycle. Turning main power "OFF" and then "ON" or cycling the thermostat will not reset a hard-lockout condition. Wait five seconds after turning on main power before pushing the reset button when the ignition module is in a hard lockout. The ignition module will go into a soft lockout if conditions of low air, low voltage or low hot surface igniter current are present. A soft-lockout condition will operate the combustion air fans for the post purge cycle and then the ignition module will pause for approximately five minutes. At the end of this timed pause, the ignition module will attempt a new trial for ignition sequence. If the soft-lockout fault condition has subsided or has been corrected at the end of the timed pause, main burner ignition should be achieved with the resumption of the normal trial for ignition sequence. If the control sensed fault is not corrected, the ignition module will continue in the soft-lockout condition. If the electronic thermostat opens during the soft-lockout period, the ignition module will exit soft lockout and wait for a new call for heat from the thermostat. A soft-lockout condition may also be reset by manually cycling the thermostat or turning the main power switch "OFF" and then "ON" after the control sensed fault has been corrected.

Diagnostic Status Indication

The ignition module has an LED which indicates the status of the safety circuits. A remote Ignition Module Status indicating light is wired from the ignition module Status LED and mounted on the side diagnostic panel. The flashing operation of this light indicates the diagnostic status of the ignition control module. The status LED, mounted on the ignition module flashes a code sequence from the Ignition Module to indicate the status of the ignition process. See TABLE-N for the flashing diagnostic status codes as signaled by the ignition module.

Ignition and Control Timings

Proven Pilot Hot Surface Ignition System F9 is standard on models 495,000 through 2,065,000 Btu/hr and M9 is optional on models 495,000 through 2,065,000 Btu/hr with One Hot Surface Ignition Module.

Hot Surface Ignition Module Timings (Nominal)

Prepurge:

15 Seconds

Hot Surface Igniter Heat-up Time:

25- 35 seconds

Main Burner Flame Establishing Period:

4 Seconds

Failure Response Time:

0.8 Seconds at less than 0.5 μ A flame current

Flame Current:

5 - 15 μ A

Time Delay Between Stages 1&2:

10 Seconds

Post-purge:

30 Seconds

Pump Delay Timing:

30 Seconds after burner shutdown.

Installation and Service Manual

OPERATION AND DIAGNOSTIC LIGHTS

The diagnostic control panel has up to 6 indicating and diagnostic lights to show all major steps of operation and control sensed malfunctions. This panel is located on the left end of the unit.

TABLE - O
Status LED Diagnostic Codes

Code Sequence	Condition
Constant ON	System OK, no faults present.
Constant OFF	Possible control fault, check power; LED may be effective, do not replace control if all operational sequences function properly, see Trouble Shooting Guide.
One Flash	Low Air, check air pressure switch and hoses to pressure sensing points, fan, venting and sealing of pressurized chamber. Note: Brief flashing normal on fan start-up/proving.
Two Flashes	Flame without call for heat, check for a gas valve stuck in the open position, air, venting, burners and the combustion process. Fan will remain on.
Three Flashes	Lockout due to flame failure, push reset button on inner control panel after correcting ignition problem. Initial heater start up without properly bleeding air from the gas line may require multiple reset functions to achieve proper ignition.
Four Flashes	Igniter failure, igniter will not maintain minimum 2.75 amp current draw, caused by, low voltage, bad wiring/continuity, high resistance or igniter failure.
Five Flashes	Power supply problem, check for low supply voltage or transformer output less than 18VAC.
Six Flashes	Replace ignition module, internal fault.

TABLE - P
Status LED Diagnostic Codes

Code Sequence	Condition Lights
Prepurge	Operation of combustion air fan before ignition on stages 1 and 2.
Trial for Ignition	Hot surface igniter preparing to light burners.
Stage 1 On	Burners for stage 1 operating.
Stage 2 On (985,000 - 2,065,000 Btu/hr)	Burners for stage 2 operating.
Status	Remote status light for ignition module.
Alarm	Indicates flame failure on the ignition module and will indicate additional alarms if the alarm of any failure option is purchased.

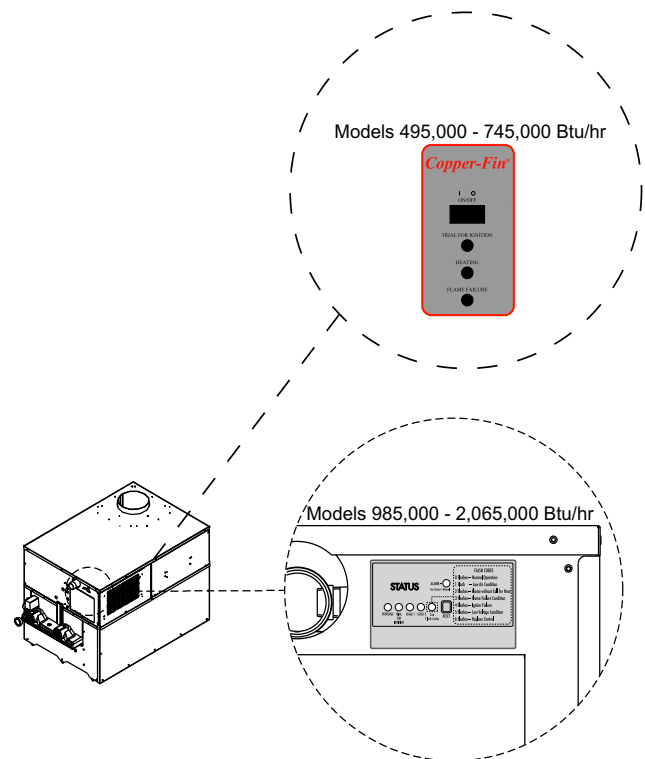

Figure 40 - Operation/Diagnostic Lights

Hydronic Heating Boilers and Domestic Water Heaters

DOMESTIC WATER HEATERS

This section applies only to those units used to supply potable hot water for domestic use. The hot water supply boiler must be installed with a storage tank.

This section contains specific instructions for those units used to supply domestic hot water. All warnings, cautions, notes and instructions in the general installation and service sections apply to these instructions. Hot water supply heaters are designed for installation with a properly sized storage tank. The use of a properly sized pump and the control of water velocity, as explained below, are important for correct operation of your water heater.

Water Velocity Control

IMPORTANT: To ensure proper velocity through the heat exchanger, you must regulate the temperature rise across the heat exchanger from inlet to outlet. Do this upon initial installation and periodically recheck. The correct temperature rise across the heat exchanger ensures proper velocity in the tubes. This will yield long life and economical operation from your hot water heater. Excessive lime build up in the tube is caused by too low of velocity through the tubes. Excessive pitting or erosion in the tube is caused by too high of velocity through the tubes. Take care to measure temperature rise and maintain a velocity as follows:

1. With the pump running and the water heater off, the inlet and outlet thermometers should read the same temperatures. If they do not, an adjustment must be made to your final calculation.
2. Turn the water heater "On" and allow time for the temperature to stabilize. Record the difference between the inlet and outlet temperatures. This difference will be the "temperature rise".
3. Compare the temperature rise on the heater with the required temperature rise in TABLE-Q. Should adjustment be needed, proceed as follows:

If the temperature rise is too high, the water velocity is too low. Check the following:

1. Check for restrictions in the outlet of the water heater.
2. Be sure all valves are open between the water heater and the tank.

3. Check the pump to be sure it is running properly and that the pump motor is running in the proper direction (see arrow on volute housing).
4. Be sure the installed circulation pipes between the water heater and storage tank are not less than 2 1/2" in diameter on models 985,000 - 2,065,000 Btu/hr.
5. Common manifold piping for multiple unit installations will require larger minimum pipe sizes and tank circulating tappings to ensure proper flow. See TABLE-R.

If the temperature rise is too low, the water velocity is too high. Adjust as follows:

1. Slowly throttle the valve on the outlet side of the water heater until the temperature rise is steady at the required temperature rise as noted in TABLE-Q.
2. Sustained high water velocity and low temperature rise may result in pitting or erosion of the copper tubes in the heat exchanger. This is a non-warrantable failure. Temperature rise must be properly adjusted to achieve the specified flow rate.

Required Temperature Rise

Based on heating potable water with a hardness of 5 to 25 grains per gallon and/or total dissolved solids not exceeding 350 ppm, see *Water Chemistry*, page 37.

**TABLE - Q
Temperature Rise Chart**

Btu/hr Input	Temperature Rise °F
495,000	15
645,000	19
745,000	22
985,000	18
1,255,000	23
1,435,000	26
1,795,000	32
2,065,000	37

Installation and Service Manual

Water Chemistry

The required temperature rise and the standard pump sizing are based on the heating of potable water with a hardness of 5 to 25 grains per gallon and a total dissolved solids not exceeding 350 ppm. Consult the appliance manufacturer when heating potable water exceeding these specifications. Heating of high hardness and/or high total dissolved solids water will require a larger circulating pump, an optional cupro-nickel heat exchanger and a revised temperature rise specification based on the water chemistry of the water to be heated. Water with a hardness of less than 5 grains per gallon will usually have a low pH which can be aggressive and corrosive causing non-warrantable damage to the heater, pump and associated piping. Corrosion due to water chemistry generally shows up first in the hot water system because heated water increases the rate of corrosive chemical reactions.

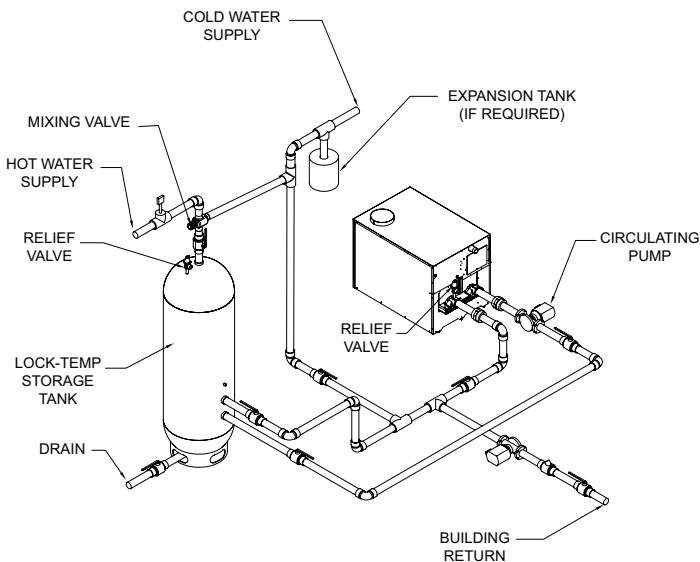

Figure 41 - Typical Water Heater Piping with Storage Tank

Pipe Size Requirements

Table-R, pipe sizing chart provides the minimum pipe size for common manifold piping to ensure adequate flow.

TABLE - R
Pipe Sizing Chart

495,000 - 745,000		985,000 - 2,065,000	
Number of Units	Common Pipe Size (Min)	Number of Units	Common Pipe Size (Min)
1	2"	1	2 1/2"
2	3"	2	4"
3	3"	3	4"
4	4"	4	5"
5	5"	5	6"
6	5"	6	6"

Circulating Pump

1. The water heater must be connected to a properly sized pump that circulates water between the heater and storage tank.
2. The pump is sized to heater input and water hardness. Care should be taken to size the pump correctly. See *Water Chemistry* on this page.
3. The water heater is equipped with a factory-supplied pump delay system in accordance with the requirements of the latest edition of ASHRAE 90.1.
4. Lubricate the pump to the manufacturer's recommendations. Pump damage due to inadequate lubrication is non-warrantable.
5. Standard water heaters are furnished with the following circulating pump. Mount the pump on the unit's inlet water connection.

495,000 -745,000 Btu/hr Models
1/4 HP, 120 VAC, 5.8 Amps

985,000 -2,065,000 Btu/hr Models
1/2 HP, 120 VAC, 7.4 Amps

This pump is sized based on installation of a single storage tank and heater in close proximity. If the number of fittings and straight pipe exceeds the quantities shown in this section, a larger pump will be required.

The standard pump selection is based on the following pipe and fittings from the unit to the storage tank:

Hydronic Heating Boilers and Domestic Water Heaters

DOMESTIC WATER HEATERS Continued

6 90° elbows 2 ball valves
 2 unions 1 cold water tee
 Not more than 45 feet of straight pipe.

IMPORTANT: For every elbow and tee in excess of those shown above, deduct 5 feet from maximum allowable straight pipe in heater to tank circulating loop.

Minimum Pump Performance

This is based on heating potable water with a hardness of 5 to 25 grains per gallon and/or total dissolved solids not exceeding 350 ppm. See *Water Chemistry*, page 37.

TABLE - S Minimum Pump Performance		
BTU/hr Input	GPM	Ft.Hd.
495,000 - 745,000	60	10
985,000 - 2,065,000	90	15

Heat Exchanger

This is a highly sophisticated heat exchanger, designed to carry water in such a way that it generates a scouring action which keeps all interior surfaces free from build up of impurities. The straight line, two pass design of the tubes sends water into the headers at a properly rated velocity. The configuration of the headers, in turn, creates a high degree of turbulence which is sufficient to keep all contaminants in suspension. This “scouring action” provides greater cost savings for owners. Tubes are always able to transfer heat at peak efficiency. Every surface within this water containing section is of a non ferrous material, providing clear, clean, rust free hot water. Straight copper tubes finned on the outside for maximum heat transfer and coated cast iron one piece cored headers make up an entirely rust proof unit. On all models, header inspection plugs can be removed for field inspection and cleaning of copper tubes. The entire heat exchanger may be easily removed from the unit.

Potable Hot Water Temperature Control Settings

Domestic Water Temperatures

⚠ WARNING: You must take adequate care to prevent scald injury when storing water at elevated temperatures for domestic use.

This unit has an adjustable temperature control to maintain the desired water temperature set point. See *Setting Temperature Control*, page 29, for instructions to program the temperature control. The temperature control is factory preset at approximately 125°F (52°C) or less. Households with small children or invalids may require 120°F (49°C) or lower temperature hot water to reduce risk of scald injury.

Operate this high efficiency hot water heater at a temperature setting high enough to prevent condensing of the products of combustion on the unit's heat exchanger or in the attached venting system. A water temperature setting that is above the dew point of the gas combustion products should prevent condensate formation.

⚠ WARNING: To guard against scald injury, you must use a properly-sized thermostatic mixing valve to supply domestic hot water at temperatures less than 125°F (52°C).

Storing the water at a higher temperature and thermostatically mixing the water increases the available quantity of mixed hot water, greatly reducing the possibility of condensate forming on the heat exchanger or in the venting system and helps prevent water born bacteria growth.

Some states may require a lower water temperature setting for specific applications. Check local codes or your gas supplier for domestic hot water temperature requirements.

⚠ D A N G E R

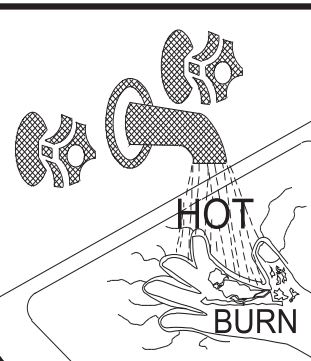

- Water temperature over 125°F (52°C) can cause severe burns instantly or death from scalds.
- Children, disabled and elderly are at highest risk of being scalded.
- See instruction manual before setting temperature at heating appliance.
- Feel water before bathing or showering.
- If this appliance is used to produce water that could scald if too hot, such as domestic hot water use, adjust the outlet control (limit) or use temperature limiting valves to obtain a maximum water temperature of 125°F (52°C).

Installation and Service Manual

Remember, no water heating system provides exact temperatures at all times. Let the system operate a few days at your desired settings to determine correct settings for your needs.

1. These units are equipped with an operating temperature control.
2. The control set points are preset to a low test setting when shipped from the factory.
3. Reset the temperature set points to the lowest settings which will satisfy hot water demands, eliminate a possible condensate problem and prevent a risk of scald injury.

⚠ WARNING: Return water temperatures must not be less than 140°F (60°C). If lower return water temperatures are required, follow the instructions for Low Temperature Return Water Systems, page 25.

4. The High-Fire Offset should normally be adjusted to “0” when supplying potable hot water for domestic use.
5. Stage firing can be achieved by adjusting the High-Fire Offset to any value other than zero. Typically, a setting of 3°F is 5°F is suitable for stage firing in a water heater application. Stage firing of a potable water heater is normally only used to replace system standby heat loss.
6. All stages of burner operation should fire when there is a major draw from the potable hot water storage system. This prevents possible condensate problems and ensures a rapid recovery of the hot water used.

Note: The High-Fire stage will be delayed by approximately 10 seconds to allow a soft start of the water heater.

IMPORTANT: When water is stored at temperatures above 125°F (52°C), a thermostatic mixing valve must be installed on the hot water outlet from the storage tank to supply lower temperature water and prevent the risk of a scald injury.

Note: This water heater, when set at a lower temperature setting, is not capable of producing hot water of sufficient temperature for sanitizing purposes.

Location of Cold Water Supply Piping Connections

Incorrect piping of the cold water supply to the system may result in excessive low temperature operation causing condensate formation on the heat exchanger and operational problems. You must install the cold water supply piping in the discharge piping from the heater to the storage tank. This allows the cold water to be tempered in the storage tank before entering the heater. See Figure 41 and typical installation drawings provided with the unit for correct piping. Higher water temperatures reduce condensate formation.

⚠ WARNING: Should overheating occur or the gas supply fail to shut off, do not turn off or disconnect the electrical supply to the pump. Instead, shut off the gas supply at a location external to the unit.

High Water Temperature Limit Control

The unit is equipped with an adjustable setting, auto-reset high water temperature limit control. The hot water heater temperature limit control has a maximum limit setting of 200°F (93°C). If water temperature exceeds the set point, the limit will break the control circuit and shut down the unit. The limit control will only be reset after the water temperature has cooled below the set point of the limit. The high water temperature limit control is mounted in the outlet side of the front header. A manual reset high water temperature limit control is available as an optional control.

Optional Relief Valve

This water heater is normally supplied with a temperature and pressure relief valve(s) sized in accordance with applicable codes. Units may be supplied with an optional pressure only relief valve(s). When a water heater equipped with this optional relief valve is piped to a separate storage vessel, the storage vessel **MUST** have a properly installed temperature and pressure relief valve which complies with local codes.

Thermal Expansion

A relief valve which discharges periodically may be due to thermal expansion in a closed system. A hot water supply boiler installed in a closed system, such as one with a backflow preventer or check valve installed in the cold water supply, shall be provided with means to control expansion. Contact the water supplier or local plumbing inspector on how to correct this situation. Do not plug or cap the relief valve discharge!

Cathodic Protection

Hydrogen gas, which is extremely flammable, can be produced in a hot water system that has been unused for a long period of time (generally two weeks or more). To prevent the possibility of injury under these conditions, open the kitchen sink hot water faucet for several minutes before using any electrical appliance connected to the hot water system. If hydrogen is present, there will be an unusual sound such as air escaping through the pipe as the hot water begins to flow. Do not smoke or have open flames near the faucet at this time.

Hydronic Heating Boilers and Domestic Water Heaters

CLEANING AND MAINTENANCE

Listed below are items that must be checked to ensure safe reliable operations. Verify proper operation after servicing.

⚠ CAUTION: Label all wires prior to disconnection when servicing controls. Wiring errors can cause improper and dangerous operation.

Appliance Area

Keep appliance area clear and free from combustible materials, gasoline and other flammable vapors and liquids.

Water Circulating Pump

Inspect pump every six months and oil as necessary. Use SAE 30 non-detergent oil or lubricant specified by pump manufacturer.

Burner Flames

Visually check main burner flames at each start up after long shutdown periods or at least every six months. Burner viewports are located on the right and left sides of the unit.

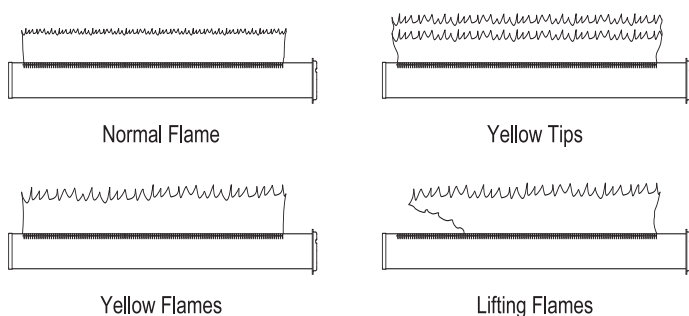

Figure 43 - Flame Pattern Illustration

⚠ WARNING: The areas around the burner viewports are hot. Direct contact with unit could result in burns.

Normal Flame: A normal flame is blue with slight yellow tips, has a well-defined inner cone, and displays no lifting flames.

Yellow Tips: The usual causes for yellow tips on the burner flame are burner air flow blockage or partial obstruction.

Yellow Flames: The usual causes for yellow flames are primary air flow blockage to the burner(s) or excessive gas input. Correct this condition immediately.

Lifting Flames: The usual causes for lifting flames are over firing the burner(s), excessive primary air, or high draft.

If you observe improper flame patterns, examine the venting system, ensure proper gas supply, and ensure adequate supply of combustion and ventilation air.

Flue Gas Passageways Cleaning Procedures

Any sign of soot around the outer jacket, at the burners or in the areas between the fins on the copper heat exchanger indicates a need for cleaning. The following cleaning procedures must only be performed by a qualified serviceman or installer. Proper service is required to maintain safe operation. Properly installed and adjusted units seldom need flue cleaning.

IMPORTANT: All gaskets on disassembled components must be replaced with new gaskets on reassembly. Gasket kits are available from your distributor.

Burner Removal and Cleaning

1. Turn off main power to unit.
2. Turn off main manual gas shutoff to unit.
3. Remove the front outer jacket panels.
4. Disconnect manifold from gas train using union(s) just below each gas valve(s).
5. Remove mounting screws from manifold mounting brackets. Pull the manifold/orifice assembly away from burners. Repeat for each manifold assembly.
6. Remove two mounting screws from burner and slide burner out toward front of unit. Use caution to prevent damage to burners, refractory, hot surface igniter or wiring.
7. Remove soot from burners with a stiff bristle brush. Dirt may be removed from burner ports by rinsing the burner thoroughly with water. Drain and dry burners before re-installing. Damaged burners must be replaced.

When installed in a dusty and dirty location, the burners may require cleaning on a 3 to 6 month schedule or as needed, based on severity of contamination. Contaminants can be drawn in with the combustion air. Non combustible particulate matter such as dust, dirt, concrete dust or dry wall dust can block burner ports and cause non-warrantable failure. The standard inlet air filter will help eliminate dust and dirt from entering the unit. Use extreme care when operating a unit for temporary heat during new construction. The burners could require a thorough cleaning before the unit is placed in service.

Installation and Service Manual

Heat Exchanger Cleaning

1. While burners are removed, check the heat exchanger surface for sooting. If present, heat exchanger must be cleaned and problem corrected. Proceed as follows.
2. Remove gas manifold(s)/orifice assemblies as described in steps 1 through 5 in *Burner Removal and Cleaning*, page 40.
3. Disconnect wiring from the hot surface igniter and hose from the burner pressure tap.
4. Remove inner jacket panel mounting screws and slide door assembly out toward front of the unit. Use caution to prevent damage to the refractory and hot surface igniter.
5. Check "V" baffles and frame runners along front and back edges of heat exchanger. Remove and clean if necessary.
6. Remove soot from heat exchanger with a stiff bristle brush. Use a vacuum to remove loose soot from surfaces and inner chamber.
7. The heat exchanger can be removed by sliding towards the front of the unit. Once the heat exchanger is removed from the unit, a garden hose can be used to wash the tubes to ensure that all soot is removed from the heat exchanger surfaces. Note: Do not wet the unit's refractory.
8. Ensure that all burner ports are cleaned to remove any soot. See *Burner Removal and Cleaning*, page 40.
9. Carefully reinstall the heat exchanger, "V" baffles, and frame runners if removed from the unit. Note: Make sure frame runners seal securely where they contact the front and rear compartment refractory.
10. Carefully reinstall inner jacket panels, burners, manifolds, wires and hoses. Use new gasket material to ensure a proper air seal.
11. Reassemble all gas and water piping. Test for gas leaks.
12. Reassemble outer jacket panels.
13. Cycle unit and check for proper operation.

Electrical

This unit uses a transformer to supply a low voltage control circuit. The voltage on the secondary side should be 24 to 28VAC when measured with a volt meter. Larger models have a 7AMP circuit breaker provided on the secondary side of the transformer. A tripped circuit breaker indicates a short in the 24VAC controls that must be corrected.

Combustion and Ventilation Air

Combustion Air Filter (Models 985,000 - 2,065,000 Btu/hr Only)

This unit has a standard air filter(s) located behind the combustion air inlet panel(s). This filter helps ensure clean air is used for the combustion process. Check this filter every month and replace when it becomes dirty. The filter size is 12" x 16" x 1" (30.5cm x 40.6cm x 2.5cm). You can find this commercially available filter at any home center or HVAC supply store.

To install filter, see *Combustion Air Filter*, page 8.

Air Flow

Check frequently to be sure the flow of combustion and ventilation air to the unit is not obstructed.

Combustion Air Fan

These units use a fan-assisted combustion process. These units have one fan to supply combustion air to the burners.

Fan Cleaning

Check each combustion air fan every six months. Clean fan as required when installed in a dusty or dirty location. Oiling is not required.

Combustion Air Fan Adjustment

The combustion air fan is factory preset and should not need adjustment in most cases. Follow the steps below to adjust the fan if a continuous Low Air Status Code occurs.

Check for proper installation and draft in the venting system. Correct as required.

Adjusting Differential Air Pressure

The following is a recommended method for setting the differential air pressure (ΔP) for the fan.

Hydronic Heating Boilers and Domestic Water Heaters

CLEANING AND MAINTENANCE CONTINUED

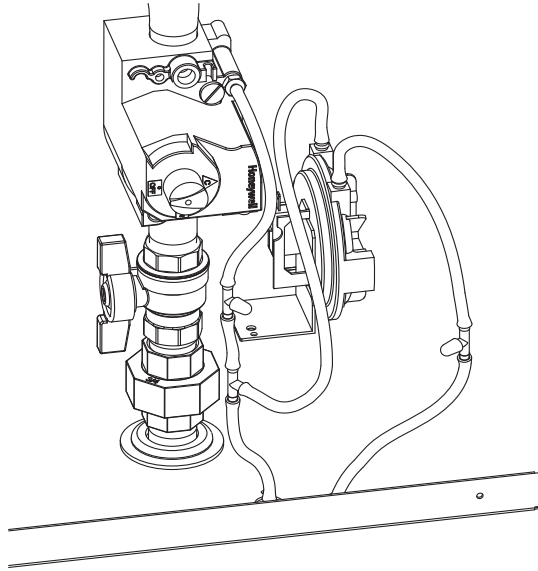
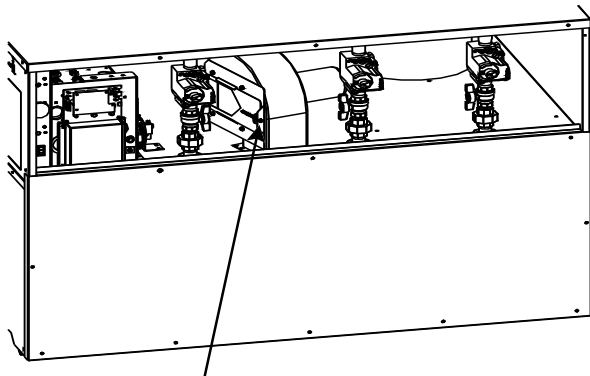

Figure 43 - Air Pressure Switch



Turn the adjustment screw on the air shutter to open or close shutter.

Figure 44 - Adjusting Air Shutter

Set Up Procedure

To the left of the fan is an air pressure switch with a large and a small tube delivering pressure from points inside the unit (see Figure 43). The pressure in the large tube is the chamber pressure. The pressure in the small tube is the burner pressure. They act together to make the pressure switch. By disconnecting the caps from the tees in the pressure switch hoses and connecting them to either side of a manometer, you can read the differential pressure to the switch.

The "+" connection on the manometer connects to the tee in the tubing from the unit's front chamber and the "-" connection on the manometer connects to the tee in the small tubing from the burner.

Upon a call for heat, the fan will run for about 90 seconds before going into soft lockout. If necessary, turn the power to the unit OFF and then back ON again to recycle the fan.

Note: If the unit has been firing recently, allow the unit to cool for five minutes with the fan running before beginning the adjustment procedure.

Note: Retain the plastic caps removed from the tees for reinstallation when complete.

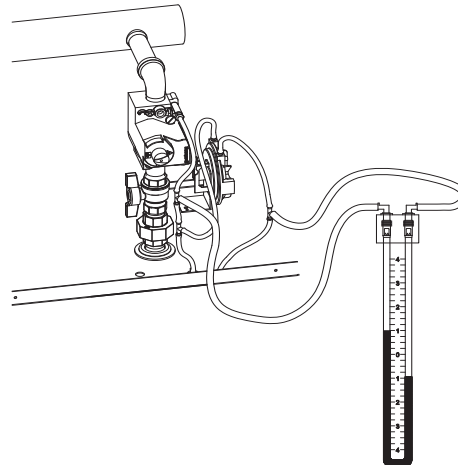

Figure 45 - Combustion Air Adjustment with a Manometer to set Differential Pressures

Adjustment Procedure: 495,000 - 1,255,000 Btu/hr Models

1. Remove the upper front jacket panels from the unit to access the upper chamber.
2. Locate the air shutter on the side of the fan housing (see Figure 44). Turn the adjustment screw on the air shutter to open or close the shutter. Increase air shutter opening to increase air pressure. Decrease air shutter opening to decrease air pressure.
3. Adjust the air shutter until the differential pressure is nominally 1.2 - 1.35 inches water column for models 495,000 - 745,000 Btu/hr and 1.1 - 1.3 inches water column for models 985,000 - 1,255,000 Btu/hr. **Note:** The air chamber pressure is 1.2 inches water column for liquefied petroleum (L.P.) and 1.4 inches water column for natural. See Figure 45 on installations up to 2000 feet altitude. Contact the factory for high altitude pressure settings.
4. Once the adjustment procedure is complete, reconnect the caps to the tees in the hoses to the pressure switches and check all tubing and wire connections for a snug fit. Test fire the unit. Reinstall upper panels.

Installation and Service Manual

Adjustment Procedure: 1,435,000, 1,795,000 and 2,065,000 Btu/hr Models

1. Remove the upper front jacket panels from the unit to access the upper chamber.
2. Slightly loosen the screws that attach the fan transition box to the metal base (see Figure 46).
3. Locate the air shutter at the rear of the fan duct (see Figure 47). Move the air shutter towards the rear of the unit to increase air pressure. Move the air shutter towards the front of the unit to decrease air pressure.
4. Adjust the air shutter until the differential pressure is nominally 1.1 - 1.3 inches water column. **Note: The air chamber pressure is 1.2 inches water column for liquefied petroleum (L.P.) and 1.4 inches water column for natural.** See Figure 45 for installations up to 2000 feet altitude. Contact the factory for high altitude settings.
5. Once the adjustment procedure is complete, reattach the caps to the tees in the hoses to the pressure switch and check all tubing and wire connections for a snug fit. Test fire the unit. Reinstall upper panels.

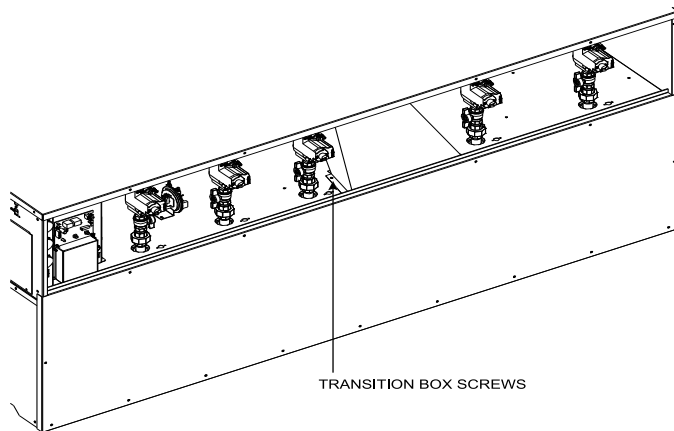

Figure 46 - Loosening the Transition Box Screws, 1,435,000, 1,795,000 and 2,065,000 Btu/hr Models Only

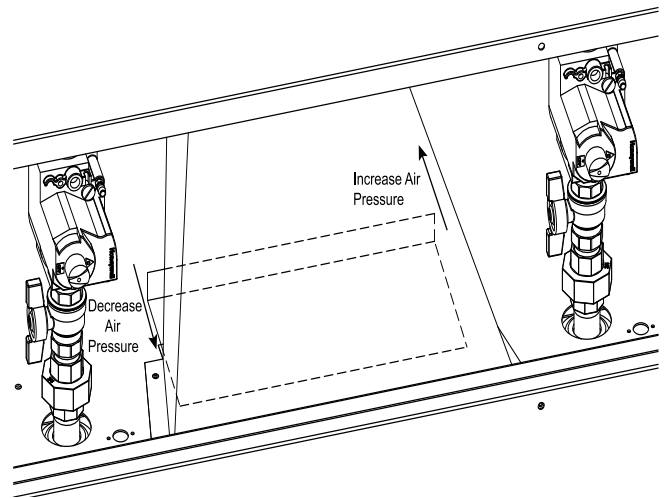

Figure 47 - Adjusting Air Shutter

Servicing Hot Surface Igniter and Ignition Module

This unit uses a proven hot surface ignition module and a hot surface igniter. The hot surface ignition module is not repairable. Any modification or repairs will invalidate the warranty.

⚠ WARNING: Do not attempt to repair a faulty hot surface igniter or ignition module. Any modification or repairs may create hazardous conditions that result in property damage, personal injury, fire, explosion and/or toxic gases.

Hydronic Heating Boilers and Domestic Water Heaters

CLEANING AND MAINTENANCE CONTINUED

A faulty hot surface igniter or ignition module must be replaced with an identical part. A specification igniter and ignition module for this specific unit is available from your local distributor. **Do not use general purpose field replacement ignition modules or igniters.**

Ignition System Checkout

1. Turn off gas supply to unit.
2. Turn electric power on.
3. Adjust the set point on the temperature control to a setting above water temperature or to the highest safe setting.
4. The igniter will cycle on trial for ignition.
5. The ignition module will lock out and turn the alarm light on.
6. Adjust the Set Point Differential and High-Fire Offset to the desired settings.
7. Turn on gas supply.
8. Press the module reset button to reset the ignition module. This is a red button beside the ignition module or on the diagnostic panel on the header-end of the unit.
9. If ignition system fails to operate properly, repair work must be performed by a qualified service person or installer.

SEQUENCE OF OPERATION

OVERVIEW

This sequence of operation can be considered the order of events in sequential order that occur after the appliance has received a call for heat. The process begins with 120VAC power entering the appliance and ends with the appliance going into an idle state after completion of a successful call for heat.

Note: The following descriptions do not include remotely connected devices that may be connected to the appliance. Refer to the wiring diagram for actual point to point wiring connections that show power delivery.

1. The POWER switch is placed in the "ON" position.
2. 120VAC power is supplied to the control transformer along with L1 and F1 on the ignition module.
3. 24VAC is supplied to the electronic temperature control, the ignition module and the adjustable high limit control.
4. 24VAC is then supplied to the auxiliary limit control (if equipped).
5. If equipped, 24VAC is supplied to a low water cut-off and then to the high and low gas pressure switches.
6. 24VAC is supplied to the continuous alarm terminals A1 and A2 and then to the remote stage one terminal strip, 1C and INO.

7. 24VAC is supplied to the electronic temperature control.
8. The electronic temperature control then calls for heat.
9. 24VAC is supplied to the intermittent alarm field safety contacts, B1 and B2.
10. 24VAC is supplied to the water flow switch (if equipped).
11. 24VAC is supplied to the TH terminals on the ignition module.
12. As power is applied to the TH terminals on the ignition module, 120VAC is switched from the F2 terminal to start the combustion air fan at full speed on the 495,000 - 745,000 Btu/hr models and at low speed on the 985,000 - 2,065,000 Btu/hr models.
13. 24VAC is supplied to the C terminal of the air pressure switch. As the low air switch makes, power is supplied to the ignition module.
14. 24VAC is then supplied to the PS terminals on the ignition module as the air pressure switch makes to prove fan operation..
15. The combustion air fan operates for the pre-purge period.
16. At the end of the pre-purge, 120VAC is applied to the hot surface igniter and the trial for ignition light.
17. The hot surface igniter proves 1800 F (982 C) ignition temperature by current draw through the ignition module.
18. The ignition module supplies voltage to the MV terminals on to the gas valve(s).

F9 SINGLE STAGE FIRING

19. All gas valves on the 495,000 - 745,000 Btu/hr models and approximately half of the valves on the 985,000 - 2,065,000 Btu/hr models open, supplying gas to the orifice and burner inlet to pre-mix.
20. The gas/air mixture is forced into the burner and out of the burner ports under pressure.
21. The hot surface igniter lights the gas/air mixture and then serves as a flame sensor to prove main burner flame by rectification.
22. After a time delay of 10 seconds, the remaining gas valves on the 985,000 - 2,065,000 Btu/hr models open, supplying gas to the remaining burners.
23. The gas/air mixture is forced out of the burners and out of the burner ports under pressure.
24. The burners light by carryover from the burners currently firing.
25. The heater is now firing at full rated input.

M9 MODULE FIRING

26. The first stage gas valve(s) opens and supplies gas to the orifice and burner inlet to pre-mix.
27. The gas/air mixture is forced into the burner and out of the burner ports under pressure.
28. The hot surface igniter lights the gas/air mixture and then serves as a flame sensor to prove main burner flame by rectification.

Installation and Service Manual

29. Burners are now firing for approximately 50% of the heater's input.
30. 24VAC is supplied from the second stage of the electronic temperature control across the 2C and 2NO terminals on the terminal strip on to a control to a relay.
31. The control relay switches the fan on the 985,000 - 2,065,000 Btu/hr models to high speed and energizes the gas valves for the remaining 50% of burner input.
32. The remaining gas valves open and supply gas to the orifice inlet to pre-mix.
33. The gas/air mixture is forced out of the burner ports and light by carryover from the burners currently firing.
34. The heater is now firing at full rated input.

HEAT TRANSFER PROCESS

35. Heated products of combustion pass over the heat exchanger transferring heat to the water.
36. The rate of flue product movement is controlled by "V" baffles on the heat exchanger to maximize heat transfer.
37. Flue products pass into the flue collector and are exhausted from the unit.

END OF SEQUENCE

38. Set point for the high fire on the electronic temperature control is satisfied.
39. Power to all valves is turned OFF on F9 systems and power to the high fire gas valves is turned OFF on M9 systems.
40. The water temperature continues to rise and the set point for low fire is satisfied (M9).
41. Power to the low fire gas valves is turned OFF (M9).
42. The combustion air fan runs for a 30 second post purge timing and turns OFF.
43. The appliance is now in a Standby Mode waiting for the next "call for heat".

GLOSSARY

Power Supply (AC120VAC/60Hz)

120VAC/60Hz/1PH power connects to black (line) and white (neutral) wires located within an electrical wiring box located on the left side of the unit. A green chassis grounding wire is also provided for connection to earth ground.

ON/OFF Rocker Switch

The black line voltage wire runs directly to a single pole, single throw On/Off rocker switch located behind the front cover accessible by a thumb screw. Turning ON the rocker switch delivers line voltage to the low voltage transformer and ignition module.

Note: The On/Off switch does not provide for disconnection of power being supplied to any remotely connected devices that may be connected to the unit (i.e. pumps, louvers, power

venters, etc.). As such, it may be necessary to locate and turn off power to these items before attempting to service the unit.

Low Voltage Supply Transformer

A 120VAC to 24VAC transformer located within the control panel provides 24VAC/60Hz to many of the components located on the unit. One of its 24VAC outputs (blue) is connected to a circuit breaker and the other (yellow) is connected to chassis ground.

24VAC Circuit Breaker

A circuit breaker is provided on the 985,000 - 2,065,000 Btu/hr models for protection of the low voltage supply transformer from overloads and short circuits. The breaker is located inside the unit on the lower right corner of the control panel. Power from this breaker goes to the electronic temperature controller, ignition module and various other components and/or options on the unit. When tripped, all factory-installed 24VAC components will lose their 24VAC power.

Manual Reset High-Limit Thermostat

A manual reset high limit thermostat is provided as backup for the temperature controller. This will either be an adjustable dial or fixed temperature bulb-capillary style thermostat that will trip and require resetting should water temperature exceed its settings. When tripped, all controls remain powered, but 24VAC is prevented from being delivered to the ignition module's thermostat input.

EMS/Sequencer/Remote Aquastat Terminals

The EMS/sequencer/remote aquastat terminals are provided for connection of the unit to an external energy management system or sequencer and are located along the top edge of the terminal strip located within the electrical wiring box. In addition to providing a means to externally stage fire the unit, these terminals also provide for remote shutdown and override by routing through dry contacts from external devices. Connection of the external dry contacts to these terminals requires the removal of one or more factory installed jumpers located on the terminal strip.

Safety Device Terminals

The safety device terminals ensure that no power can be delivered to the ignition module unless factory/field-installed safety devices such as flow switches and gas pressure switches are closed. These safety device terminals are located below the EMS/Sequencer/Remote Aquastat terminals located within the electrical wiring box. Two types of connections are offered: Continuous terminals provide for connection of safety devices that are desired to be constantly monitored. Intermittent terminals are provided for devices that are only monitored during a "call for heat" cycle. Connection to either of these terminals requires the removal of a factory-installed jumper located on the terminal strip.

Hydronic Heating Boilers and Domestic Water Heaters

Electronic Temperature Controller (Operator)

A 2-stage electronic temperature controller is provided on the unit and it serves to maintain a user selectable temperature set point. Ultimately, the temperature controller delivers 24VAC to the ignition module and pressure switch when it senses heat mode is desired. It also activates the pump relay. If more heat is needed, it activates the high fire stage.

Ignition Module (Controlled by Electronic Temperature Controller)

One ignition module is provided on the unit. Upon sensing the 24VAC delivered to it by the electronic temperature controller, the ignition module checks for a shorted pressure switch and then, provided the air switch isn't shorted, supplies 120VAC to its blower output relay and waits for a pressure switch signal.

Two Speed Blower (Controlled by Ignition Module and Relay Board)

A single 2-speed blower on the 985,000 - 2,065,000 Btu/hr models (single 1-speed blower on the 495,000 - 745,000 Btu/hr models) provide combustion air to the unit. The blower is provided with a high and low speed tap. The blower operates in tandem with the ignition module when a call for heat signal is received. Depending upon the number of stages in operation, the blower's speed may increase or decrease accordingly.

Pressure Switch (Activated by Blower Turning On)

One pressure switch is provided to monitor the blower On/Off operation. Upon a call for heat, 24VAC is delivered to the pressure switch. If the blower generates adequate air pressure, the pressure switch closes to deliver 24VAC to the ignition module pressure switch monitoring input terminal.

Prepurge (Ignition Module Function)

Once the ignition module sees a 24VAC input from the pressure switch, it runs the blower for approximately 15 seconds in order to purge the combustion chamber of any unburned fuel/air mixture.

Trial for Ignition (Ignition Module Function)

Once the ignition module has completed its prepurge period, it turns on the hot surface igniter. Once the hot surface igniter's current draw reaches a proper level, the ignition module begins a trial for ignition period of approximately 25 seconds to allow time for the igniter to reach the ignition temperature necessary to ignite the fuel/air mixture.

Igniter (Controlled by Ignition Module)

One igniter is provided in order to ignite the fuel/air mixture and its on/off operation is controlled by the ignition module.

Relay Board (Controlled by Electronic Temperature Controller and Ignition Module)

A small relay board is provided on the 985,000 - 2,065,000 Btu/hr models to switch the blower from low to high speed and to deliver power from the low fire stage (Stage 1) to the high fire stage (Stage 2) depending upon the electronic thermostat's settings.

Ignition (Ignition Module Function)

Once the trial for ignition period has been completed, the ignition module sends 24VAC to the gas valves on the low fire stage (Stage 1). Gas valves should open and allow gas to flow to the burners in Stage 1 being energized. The fuel/air mixture should ignite from the hot surface igniter. Once this voltage has been sent to the valves, the hot surface igniter is turned off. The ignition module then monitors the status of the flame and will either allow ignition to continue or shut down the gas valves should flame not be proven and proceed to a Flame Failure condition. If flame was proven briefly during the ignition period, the module may not proceed to Flame Failure, but rather post-purge and then go into another trial for ignition.

Heat Transfer Process (Gas Valves, Burner, and Heat Exchanger)

Once flame has been proven, the ignition module will hold the gas valves open as long as there is proof of flame and a call for heat is present. If the low fire stage cannot provide enough heat to raise the system temperature, the electronic temperature controller turns on the high fire stage. The high fire stage will operate until the system water temperature shows a gain that can be handled by low fire operation. The high fire stage shuts off at this point. When the low-fire stage alone produces more heat than is required, the electronic temperature controller turns off the call for heat.

Post-Purge (Ignition Module Function)

When 24VAC is removed from the ignition module's thermostat input, the module turns off the gas valves and maintains the blower for approximately 25 seconds in order to allow the combustion chamber to be purged of all combustion by-products.

Pump Delay (Electronic Thermostat Function)

When the electronic thermostat removes 24VAC from the ignition module, it continues to hold the pump relay on for 30 seconds in order to get the remaining heat out of the combustion chamber. The pump then turns off to prevent the heat in the water from going back into the combustion chamber and up the flue.

Idle (Electronic Thermostat Function)

After completion of the post-purge cycle, the unit will go into an idle state whereby the electronic thermostat continuously monitors the water temperature until the water temperature drops to levels that require additional heat.

SCHEMATIC DIAGRAM

MODELS 495,000 - 745,000 BTU/HR

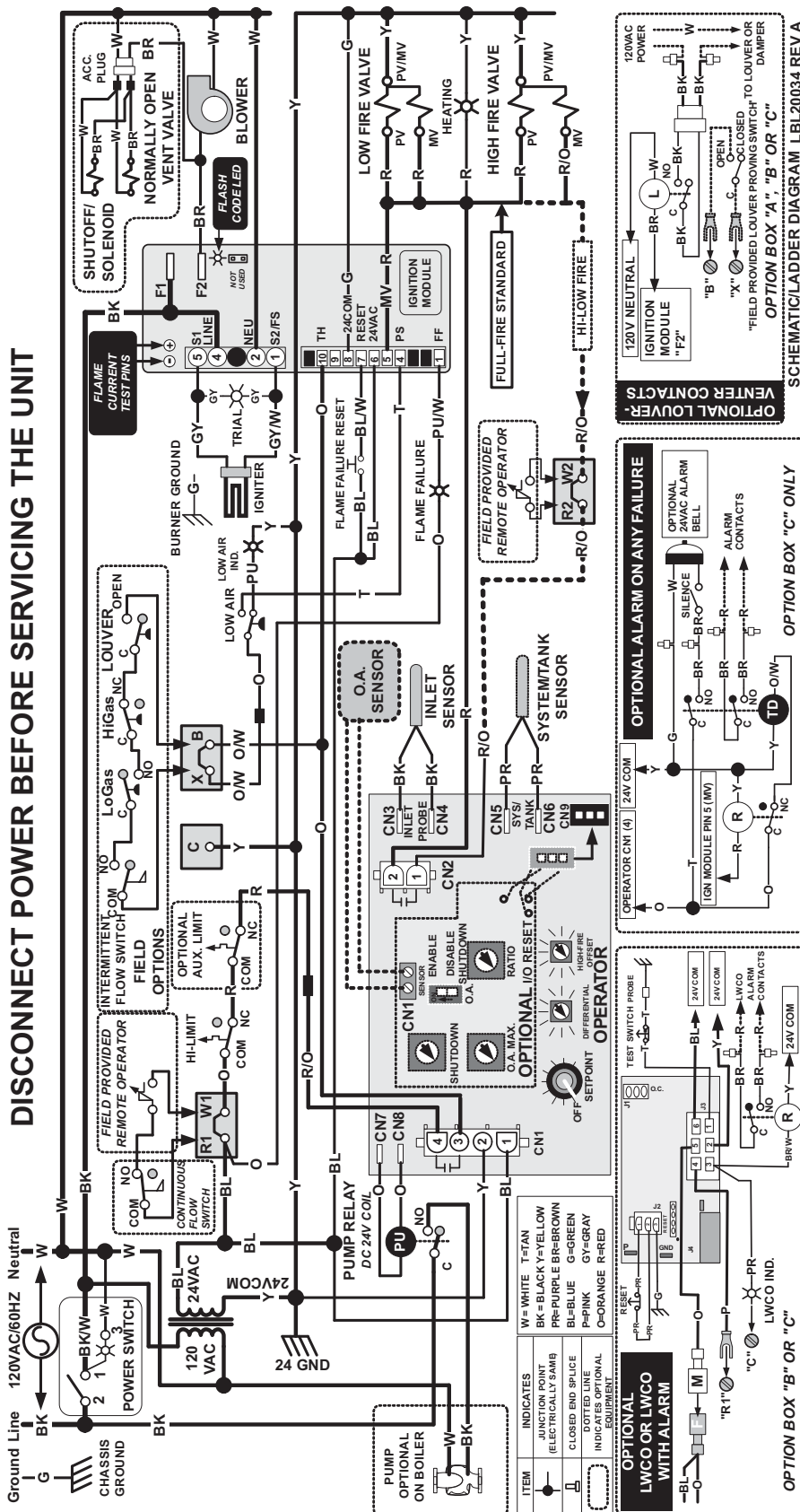

WIRING DIAGRAMS - MAIN UNIT CONNECTIONS

MODELS 495,000 - 745,000 BTU/HR

TERMINAL STRIP - SENSOR

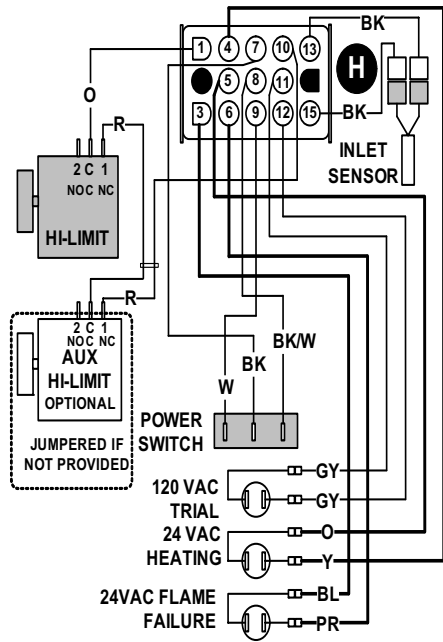
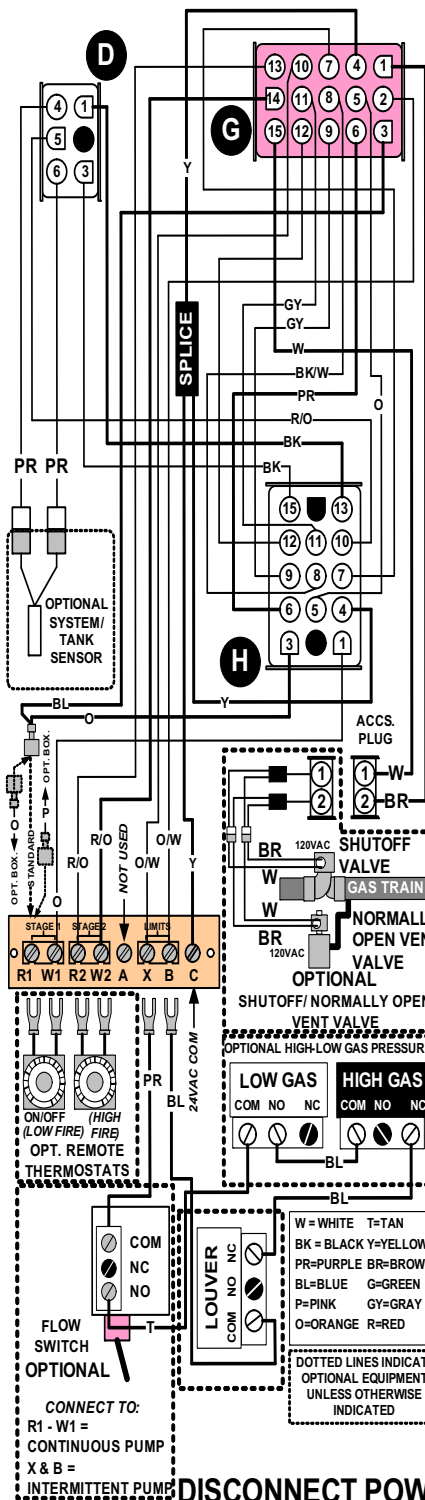

HI-LIMITS - PWR SW

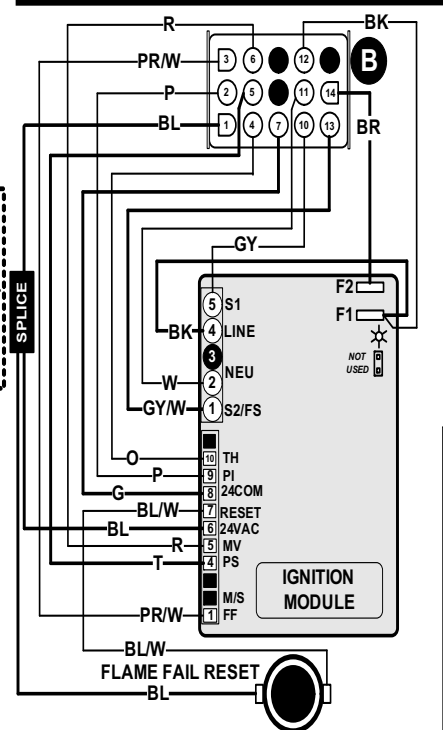

IGNITION MODULE

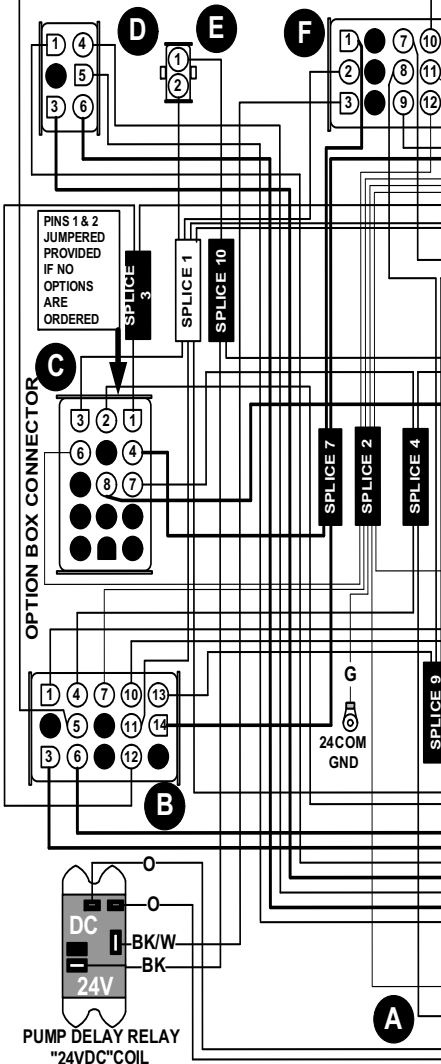

CONTROL PANEL

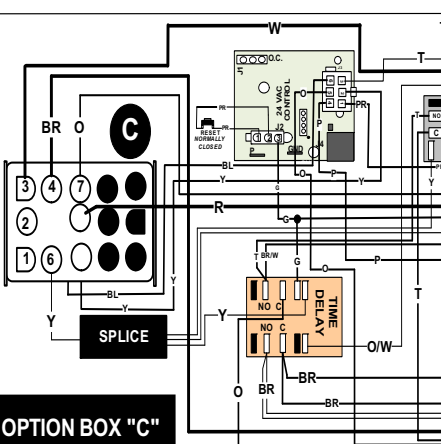

OPTION BOX "C"

X MATING BLOCKS **SPICE** SPICE

DISCONNECT POWER BEFORE SERVICING THE UNIT
WHEN REPLACING DAMAGED WIRING, USE EQUIVALENT TYPE AND GAUGE

WIRING DIAGRAMS - MAIN UNIT CONNECTIONS MODELS 495,000 - 745,000 BTU/HR (CONTINUED)

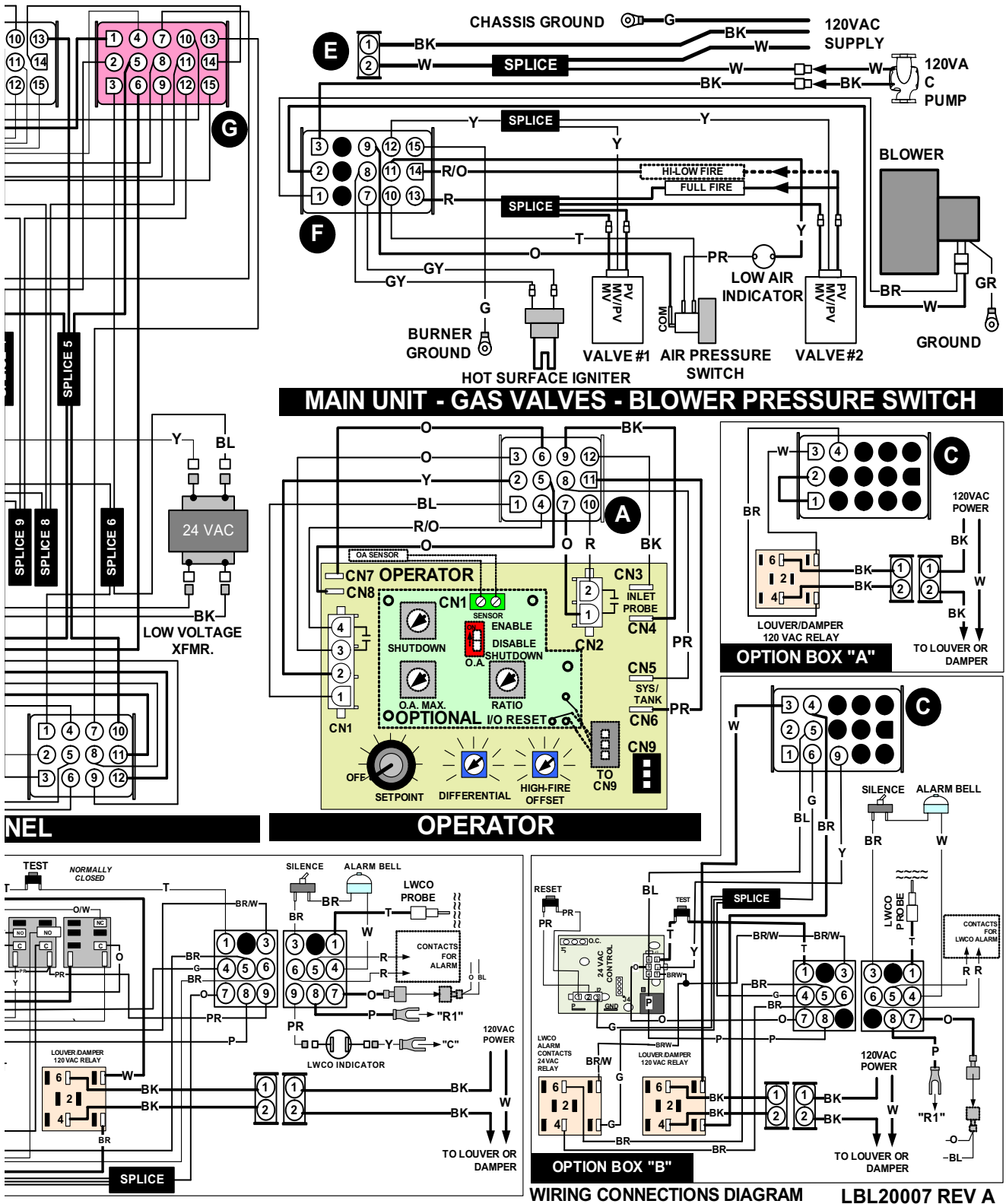

SCHEMATIC AND WIRING DIAGRAM MODELS 985,000 - 2,065,000 BTU/HR

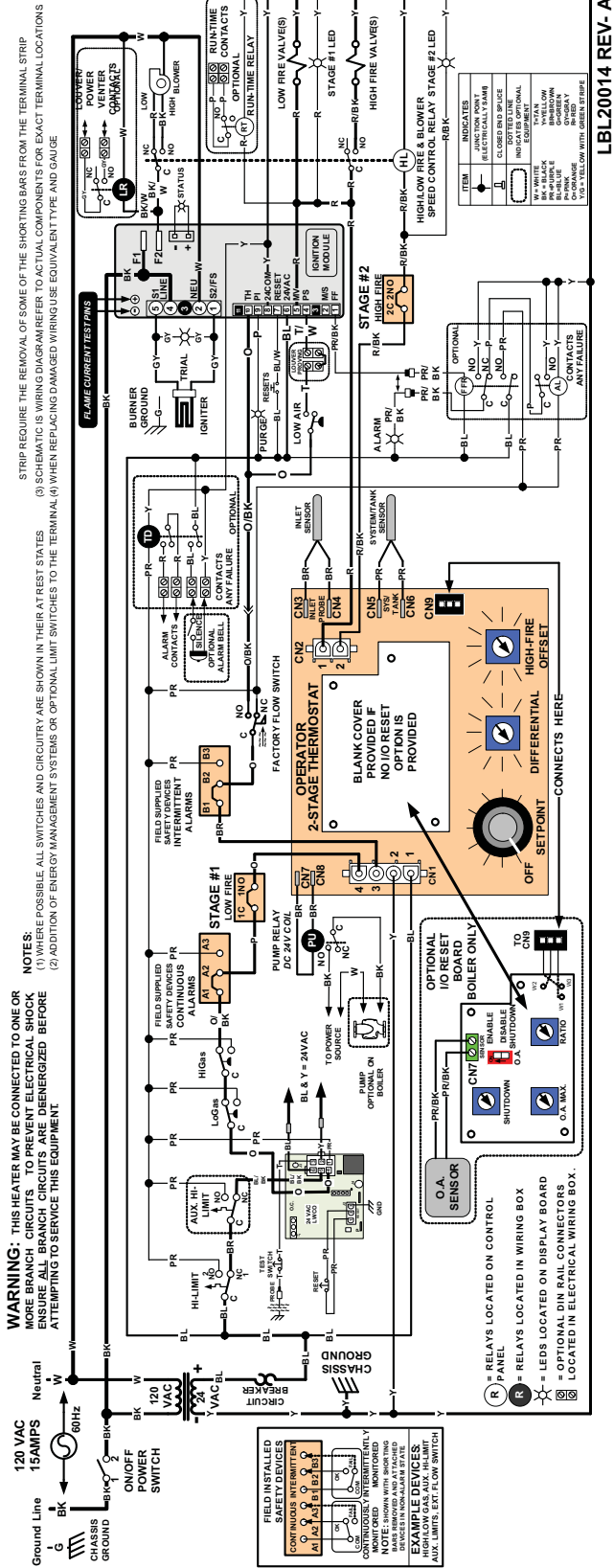

MAIN UNIT CONNECTIONS

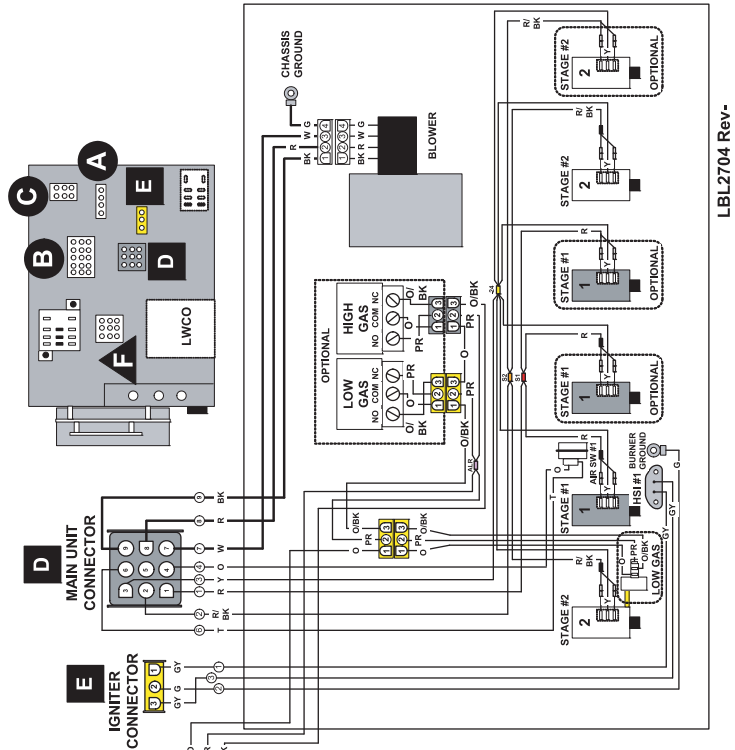

WIRING BOX CONNECTIONS

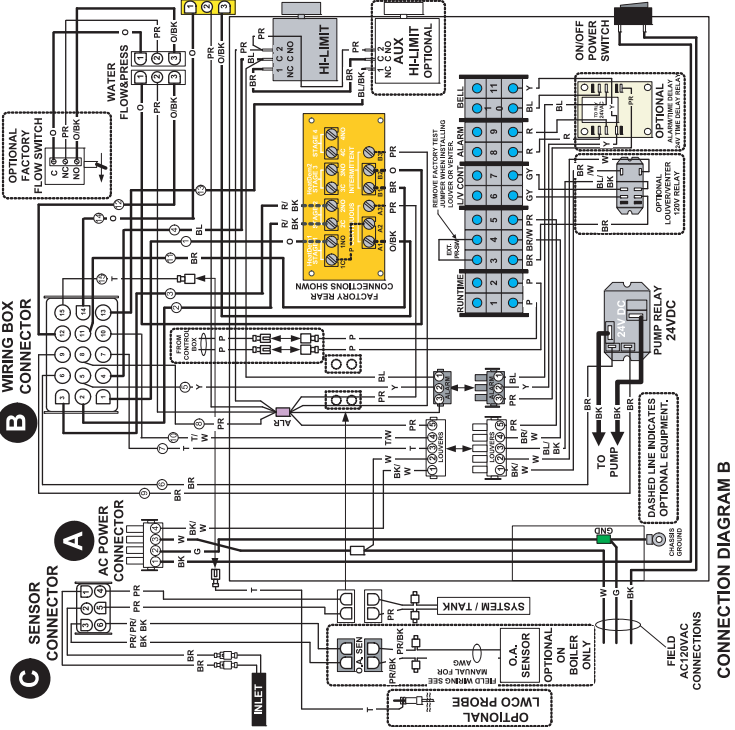

WIRING DIAGRAM - CONTROL BOX CONNECTIONS

MODELS 985,000 - 2,065,000 BTU/HR

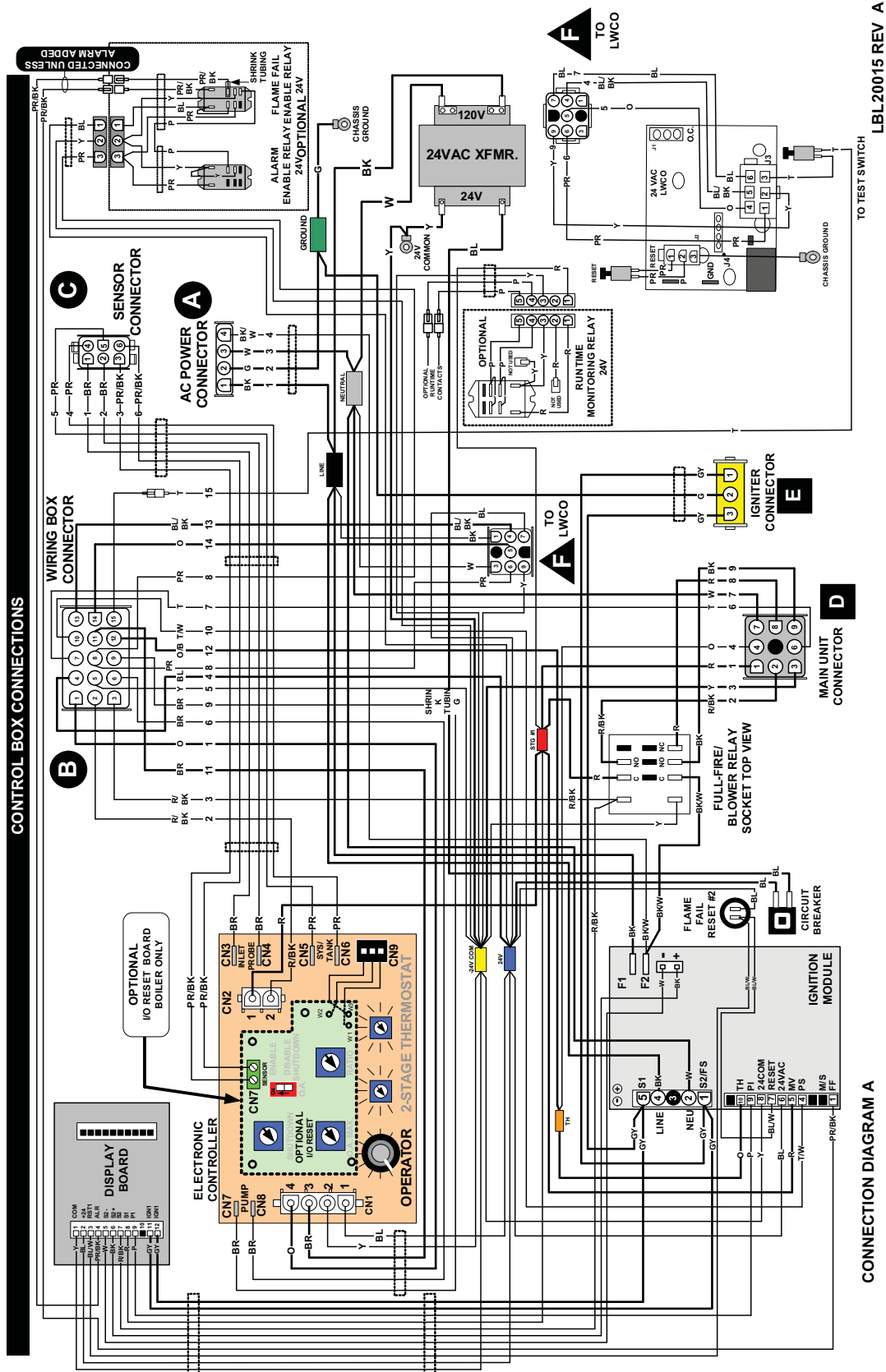

Revision 4 (CB-CW(E)-i&s-04) reflects changes made to the O.A. section.

Revision 5 (CB-CW(E)-i&s-05) reflects changes made to text on Page 21 and the LBLs on pages 47-51.

Revision 6 (ECO #C02870) reflects the addition of a mixing valve to FIG. 41 (page 37) and edits made to the scald warnings.

CB-CW(E)-i&s-06
CP-5M-1/09

Free Manuals Download Website

<http://myh66.com>

<http://usermanuals.us>

<http://www.somanuals.com>

<http://www.4manuals.cc>

<http://www.manual-lib.com>

<http://www.404manual.com>

<http://www.luxmanual.com>

<http://aubethermostatmanual.com>

Golf course search by state

<http://golfingnear.com>

Email search by domain

<http://emailbydomain.com>

Auto manuals search

<http://auto.somanuals.com>

TV manuals search

<http://tv.somanuals.com>