

Rotary Tillers

RTA2064, RTA2072, RTR2064 & RTR2072

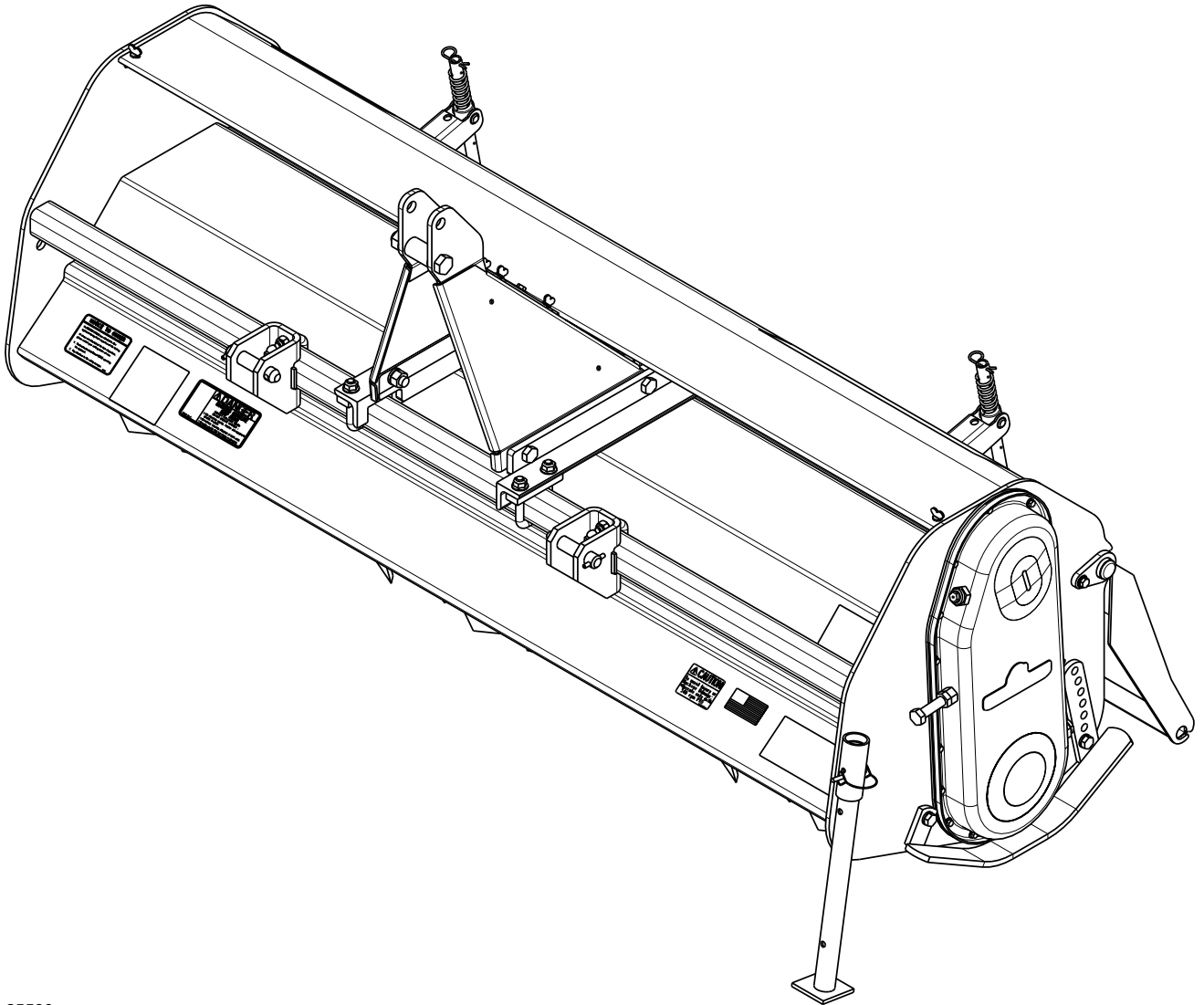

25590

311-328M Operator's Manual



Read the Operator's manual entirely. When you see this symbol, the subsequent instructions and warnings are serious - follow without exception. Your life and the lives of others depend on it!

© Copyright 2007 Printed 7/03/07

Cover photo may show optional equipment not supplied with standard unit.



Important Safety Information	1	Section 4: Maintenance and Lubrication	14
Safety at All Times	1	Maintenance	14
Look For The Safety Alert Symbol	1	Tine Replacement	14
Safety Labels	4	Driveline Protection	14
Introduction	6	Clutches With 4 Adjusting Nuts	14
Application	6	Clutch Run-In	14
Using This Manual	6	Clutch Disassembly & Assembly	15
Owner Assistance	6	Clutches With 8 Hex Socket Bolts	16
Section 1: Assembly and Set-Up	7	Clutch Run-In	16
Tractor Requirements	7	Clutch Disassembly & Assembly	16
3-Point Hitch & Shaft Cover Assembly	7	Storage	17
Driveline Guard Assembly	7	Lubrication	18
Parking Stand Assembly	7	Driveline U-Joint (Both Ends)	18
Tractor Hook-Up	9	Driveline Shaft	18
Driveline Installation	9	Bearing on Right End of Rotor Shaft	18
Section 2: Operating	11	Chaincase	19
Transporting	11	Gearbox	19
Parking	11	Section 5: Specifications & Capacities	20
General Notes for Field Operations	11	Section 6: Features & Benefits	21
Operating Check List	11	Section 7: Troubleshooting	22
Operating Instructions	12	Section 8: Appendix	23
Section 3: Adjustments	13	Torque Values Chart	23
Drive Chain	13	Notes	24
Skid Shoe	13	Warranty	25
Rear Deflector & Down Pressure Kit	13		

© Copyright 2007 All rights Reserved

Land Pride provides this publication "as is" without warranty of any kind, either expressed or implied. While every precaution has been taken in the preparation of this manual, Land Pride assumes no responsibility for errors or omissions. Neither is any liability assumed for damages resulting from the use of the information contained herein. Land Pride reserves the right to revise and improve its products as it sees fit. This publication describes the state of this product at the time of its publication, and may not reflect the product in the future.

Land Pride is a registered trademark.

All other brands and product names are trademarks or registered trademarks of their respective holders.

Printed in the United States of America.

Important Safety Information

These are common practices that may or may not be applicable to the products described in this manual.

Safety at All Times

Thoroughly read and understand the instructions given in this manual before operation. Refer to the "Safety Label" section, read all instructions noted on them.

Do not allow anyone to operate this equipment who has not fully read and comprehended this manual and who has not been properly trained in the safe operation of the equipment.

- ▲ Operator should be familiar with all functions of the unit.
- ▲ Operate implement from the driver's seat only.
- ▲ Do not leave tractor or implement unattended with engine running.
- ▲ Dismounting from a moving tractor could cause serious injury or death.
- ▲ Do not stand between the tractor and implement during hitching.
- ▲ Keep hands, feet, and clothing away from power-driven parts.
- ▲ Wear snug fitting clothing to avoid entanglement with moving parts.
- ▲ Watch out for wires, trees, etc., when raising implement. Make sure all persons are clear of working area.
- ▲ Turning tractor too tight may cause implement to ride up on wheels. This could result in injury or equipment damage.

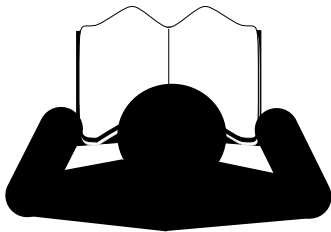

Look For The Safety Alert Symbol

The SAFETY ALERT SYMBOL indicates there is a potential hazard to personal safety involved and extra safety precaution must be taken. When you see this symbol, be alert and carefully read the message that follows it. In addition to design and configuration of equipment, hazard control and accident prevention are dependent upon the awareness, concern, prudence and proper training of personnel involved in the operation, transport, maintenance and storage of equipment.

Be Aware of Signal Words

A Signal word designates a degree or level of hazard seriousness. The signal words are:

DANGER

Indicates an imminently hazardous situation which, if not avoided, will result in death or serious injury. This signal word is limited to the most extreme situations, typically for machine components that, for functional purposes, cannot be guarded.

WARNING

Indicates a potentially hazardous situation which, if not avoided, could result in death or serious injury, and includes hazards that are exposed when guards are removed. It may also be used to alert against unsafe practices.

CAUTION

Indicates a potentially hazardous situation which, if not avoided, may result in minor or moderate injury. It may also be used to alert against unsafe practices.

For Your Protection

- ▲ Thoroughly read and understand the "Safety Label" section, read all instructions noted on them.

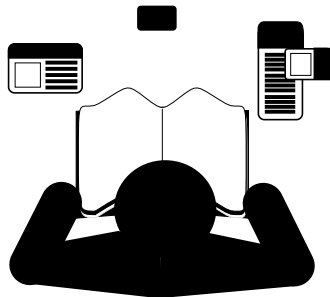

Shutdown and Storage

- ▲ Lower machine to ground, put tractor in park, turn off engine, and remove the key.
- ▲ Detach and store implements in a area where children normally do not play. Secure implement by using blocks and supports.

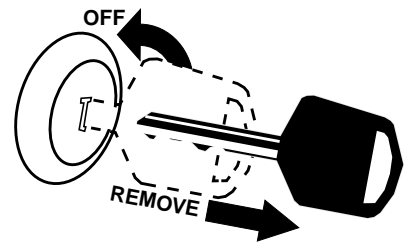

Important Safety Information

These are common practices that may or may not be applicable to the products described in this manual.

Use Safety Lights and Devices

- ▲ Slow moving tractors, self-propelled equipment, and towed implements can create a hazard when driven on public roads. They are difficult to see, especially at night.
- ▲ Flashing warning lights and turn signals are recommended whenever driving on public roads. Use lights and devices provided with implement.

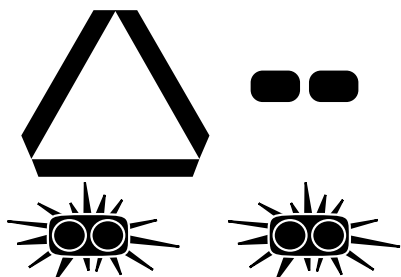

Transport Machinery Safely

- ▲ Comply with state and local laws.
 - ▲ Maximum transport speed for implement is 20 mph. **DO NOT EXCEED.** Never travel at a speed which does not allow adequate control of steering and stopping. Some rough terrain require a slower speed.
 - ▲ Sudden braking can cause a towed load to swerve and upset.
- Reduce speed if towed load is not equipped with brakes.
- ▲ Use the following maximum speed - tow load weight ratios as a guideline:
 - 20 mph** when weight is less than or equal to the weight of tractor.
 - 10 mph** when weight is double the weight of tractor.
 - ▲ **IMPORTANT:** Do not tow a load that is more than double the weight of tractor.

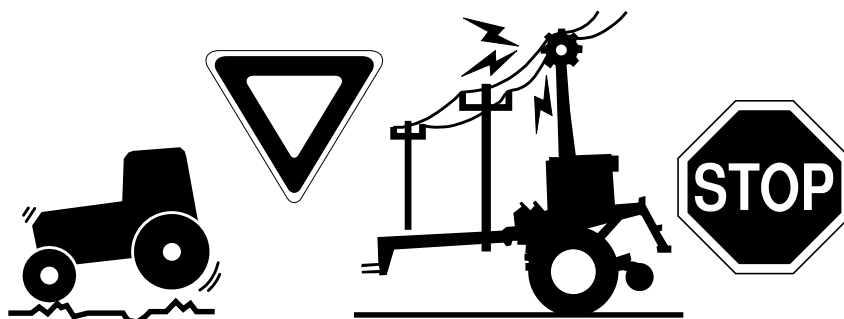

Keep Riders Off Machinery

- ▲ Riders obstruct the operator's view, they could be struck by foreign objects or thrown from the machine.
- ▲ Never allow children to operate equipment.

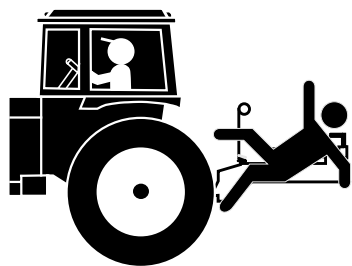

Practice Safe Maintenance

- ▲ Understand procedure before doing work. Use proper tools and equipment, refer to Operator's Manual for additional information.
- ▲ Work in a clean dry area.
- ▲ Lower the implement to the ground, put tractor in park, turn off engine, and remove key before performing maintenance.
- ▲ Allow implement to cool completely.
- ▲ Do not grease or oil implement while it is in operation.
- ▲ Inspect all parts. Make sure parts are in good condition & installed properly.
- ▲ Remove buildup of grease, oil or debris.
- ▲ Remove all tools and unused parts from implement before operation.



Important Safety Information

These are common practices that may or may not be applicable to the products described in this manual.

Prepare for Emergencies

- ▲ Be prepared if a fire starts.
- ▲ Keep a first aid kit and fire extinguisher handy.
- ▲ Keep emergency numbers for doctor, ambulance, hospital and fire department near phone.

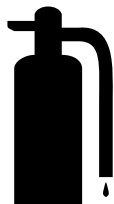
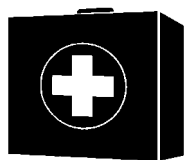
**Wear Protective Equipment**

- ▲ Protective clothing and equipment should be worn.
- ▲ Wear clothing and equipment appropriate for the job. Avoid loose fitting clothing.
- ▲ Prolonged exposure to loud noise can cause hearing impairment or hearing loss. Wear suitable hearing protection such as earmuffs or earplugs.
- ▲ Operating equipment safely requires the full attention of the operator. Avoid wearing radio headphones while operating machinery.

**Avoid High Pressure Fluids Hazard**

- ▲ Escaping fluid under pressure can penetrate the skin causing serious injury.
- ▲ Avoid the hazard by relieving pressure before disconnecting hydraulic lines.
- ▲ Use a piece of paper or cardboard, NOT BODY PARTS, to check for suspected leaks.
- ▲ Wear protective gloves and safety glasses or goggles when working with hydraulic systems.
- ▲ If an accident occurs, see a doctor immediately. Any fluid injected into the skin must be treated within a few hours or gangrene may result.

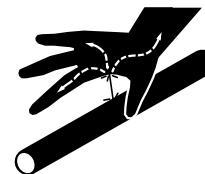

Important Safety Information

Safety Labels

1. Your tiller comes equipped with all safety labels in place. They were designed to help you safely operate your tiller. Read and follow these directions.
2. Keep all safety labels clean and legible.
3. Replace all damaged or missing labels. To order new labels go to your Land Pride dealer.
4. Some new equipment installed during repair require safety

labels to be affixed to the replaced component as specified by Land Pride. When ordering new components make sure the correct safety labels are included in the request. To order new labels go to your Land Pride dealer.

5. Refer to this section for proper label placement.

To install new labels:

- a. Clean the area the label is to be placed
- b. Peel backing from label. Press firmly on surface being careful not to cause air bubbles under label.

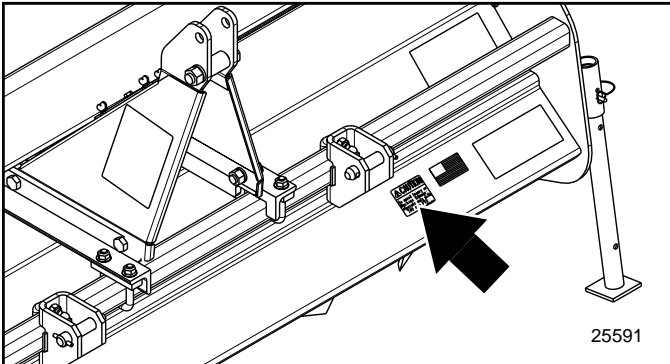

818-130C

Caution: 540 RPM

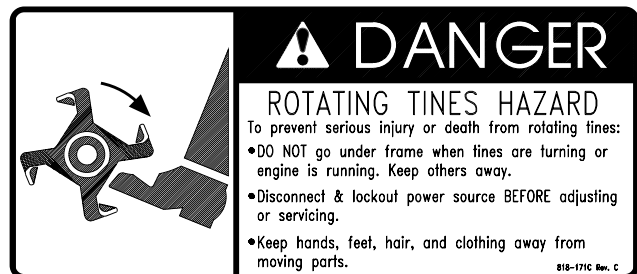
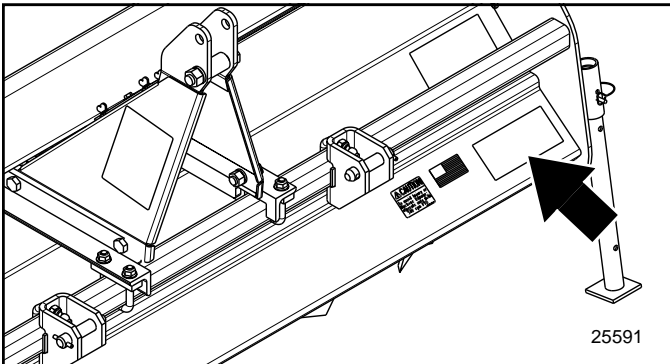

818-171C

Rotating Tines Hazard!

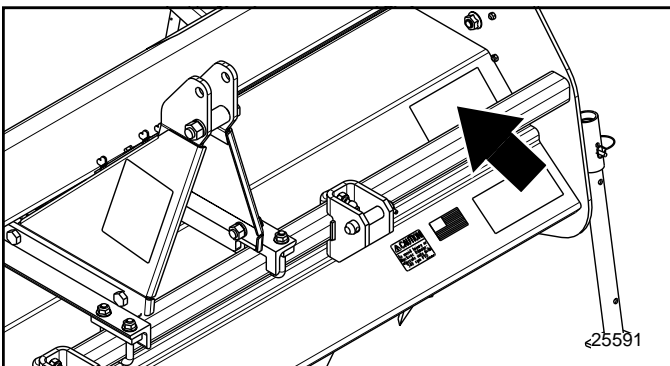

818-284C

Danger Thrown Object Hazard

Important Safety Information

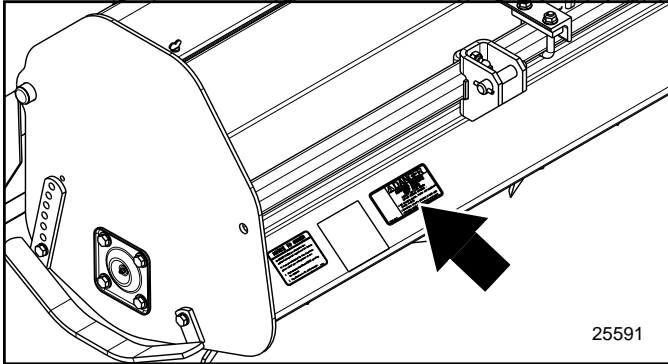

818-142C
 General Rotating Driveline

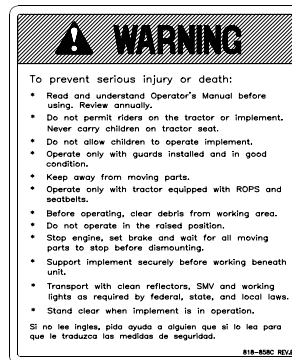
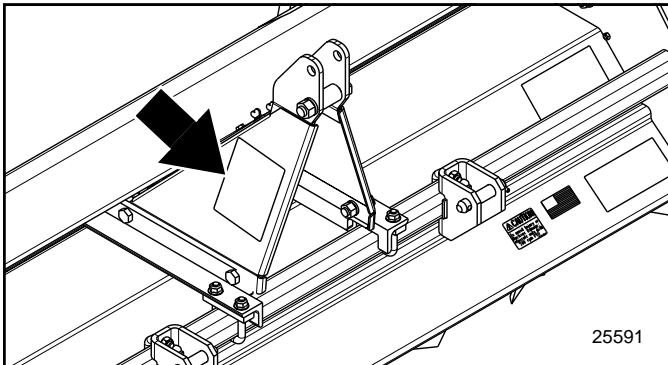

818-858C
 General Safety Instructions

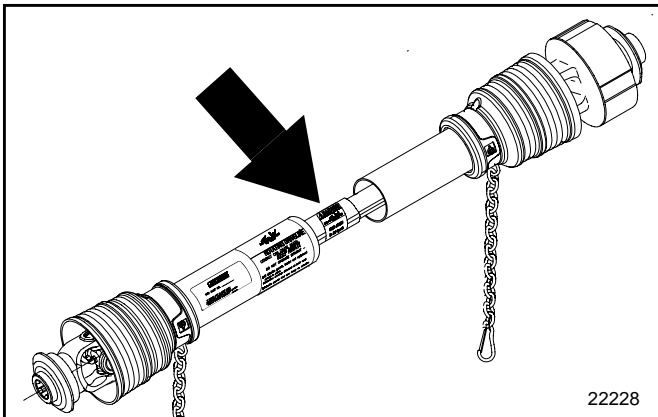

818-540C
 Shield missing - Do Not operate.

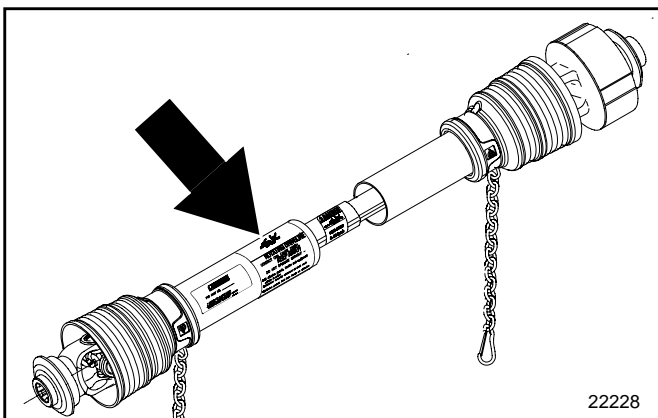

818-552C
 Rotating Driveline Hazard - Keep Away!

Introduction

Land Pride welcomes you to the growing family of new product owners.

This implement has been designed with care and built by skilled workers using quality materials. Proper assembly, maintenance, and safe operating practices will help you get years of satisfactory use from the machine.

Application

The RTA20 & RTR20 Series Rotary Tillers are just right for home gardening, landscape work, vegetable farming or food plot maintenance. Available in three widths, the 20 Series Rotary Tiller turns up hard packed ground, leaving a perfect seedbed for gardens to grass. Land Pride's RTA20 forward rotating tiller can work in all types of ground conditions, with best results being obtained in fairly mellow conditions. The RTR20 Series Rotary Tillers feature a reverse tilling action for tougher ground conditions. The reverse action "sucks" the tiller into the ground, which prohibits the tiller from "walking" on hard ground. The RTR20 Series Tiller also incorporates spring loaded "sifting" rods behind the tines to help bury large rocks and debris. The reverse action of the rotor brings material up and over the top. Rocks and vegetation cannot get through the sifting rods so they fall first. Soil continues to get sifted before it falls, building a layer of large to small dirt clods burying the rocks and vegetation. Reverse tilling can reduce the number of trips needed to turn the soil over. See "Features and Benefits", "Section 6" for additional information.

Using This Manual

- This Operator's Manual is designed to help familiarize you with safety, assembly, operation, adjustments, troubleshooting, and maintenance. Read this manual and follow the recommendations to help ensure safe and efficient operation.
- The information contained within this manual was current at the time of printing. Some parts may change slightly to assure you of the best performance.
- To order a new Operator's or Parts Manual contact your authorized dealer. Manuals can also be downloaded, free-of-charge from our website at www.landpride.com or printed from the Land Pride Service & Support Center by your dealer.

Terminology

"Right" or "Left" as used in this manual is determined by facing forward in the direction the machine will operate while in use unless otherwise stated.

Definitions

NOTE: A special point of information that the operator must be aware of before continuing.

IMPORTANT: A special point of information related to its preceding topic. Land Pride's intention is that this information should be read and noted before continuing.

Owner Assistance

The Warranty Registration card should be filled out by the dealer at the time of purchase. This information is necessary to provide you with quality customer service.

If customer service or repair parts are required contact a Land Pride dealer. A dealer has trained personnel, repair parts and equipment needed to service the Rotary Tiller.

The parts on your Rotary Tiller have been specially designed and should only be replaced with genuine Land Pride parts. Therefore, should your Rotary Tiller require replacement parts go to your Land Pride Dealer.

Serial Number Plate

For prompt service always use the serial number and model number when ordering parts from your Land Pride dealer. Be sure to include your serial and model numbers in correspondence also. Refer to Figure 1 for the location of your serial number plate.

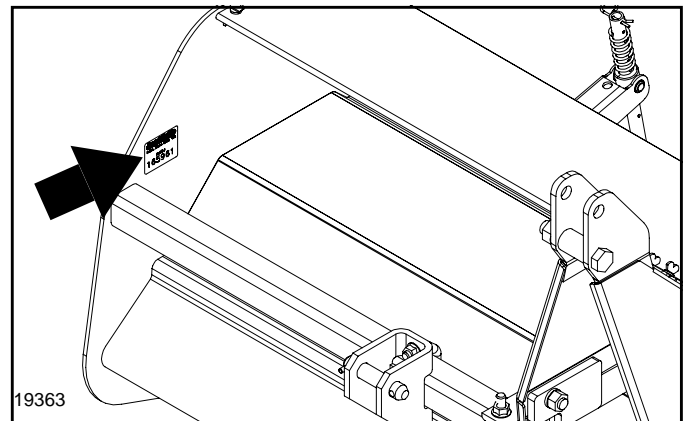

Serial Number Plate Location

Figure 1

Further Assistance

Your dealer wants you to be satisfied with your new Rotary Tiller. If for any reason you do not understand any part of this manual or are not satisfied with the service received, the following actions are suggested:

1. Discuss the matter with your dealership service manager making sure he is aware of any problems you may have and that he has had the opportunity to assist you.
2. If you are still not satisfied, seek out the owner or general manager of the dealership, explain the problem and request assistance.
3. For further assistance write to:

Land Pride Service Department

1525 East North Street

P.O. Box 5060

Salina, Ks. 67402-5060

E-mail address

lp servicedept@landpride.com

Section 1: Assembly and Set-Up

Tractor Requirements

This tiller is designed with a 3-point category I hitch. Horsepower rating of tractor should not exceed 40 PTO horsepower.

NOTE: In order to maintain steering control, ballast may have to be added to your tractor. To determine whether or not to add ballast, refer to your tractor operator's manual.



CAUTION

Do not over speed PTO or machine damage may result. This tiller is designed to be used with a tractor using a 540 RPM rear PTO.

3-Point Hitch & Shaft Cover Assembly

Refer to Figure 1-1:

1. Install right hand and left hand top hitch halves (#3) and (#4) to the inside of the hitch mounting bars bolted on the frame with 5/8" bolts (#11), nuts (#14) and lock washers (#18). Do not tighten bolts at this time.
2. Insert the top hitch spacer tube (#1) between the left hand and right hand hitch as shown and secure with the 3/4" bolt (#12), nut (#15) and lock washer (#19).
3. Tighten all bolts to recommended torques. See "Torque Values Chart" on page 23.

Driveline Guard Assembly

1. Assemble clamp (#5) to the plate (#8) with one of the wing bolts (#9).
2. Assemble the driveline guard (#6) to the top hitch with the four other wing bolts (#9).
3. Install cover (#7) to tiller with wing bolts (#9).
4. Fasten plate (#8) to the driveline guard (#6) with the 5/16" bolt (#10), flat washer (#17), lockwasher (#16) and nut (#13). The clamp (#5) should catch the lip of cover (#7).

Parking Stand Assembly

Refer to Figure 1-1:

Install the parking stand (#2) through the stand bracket and adjust stand to desired height and pin with 5/16" wire lock pin (#20).

Section 1: Assembly and Set-Up

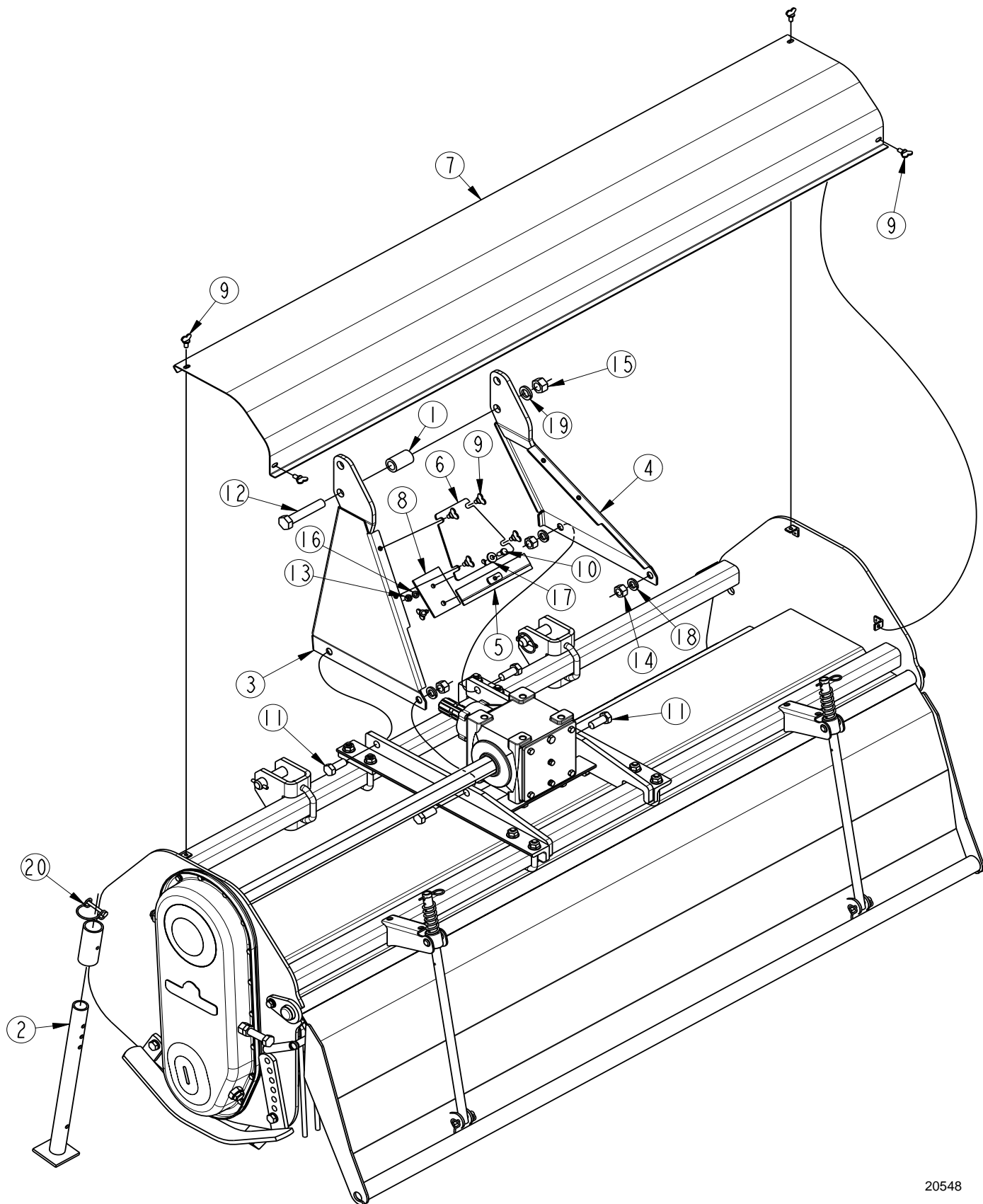

20548

Hitch, Stand & Shaft Cover Assembly
Figure 1-1

Section 1: Assembly and Set-Up

Tractor Hook-Up

Refer to Figure 1-2:

1. When using tractors with multi-speed PTO, be certain PTO is set for 540 RPM.
2. Back tractor up to tiller until lower 3-Point links are aligned with hitch clevises on tiller.
3. Secure the tractor's 3-Point lower links to the lower hitch clevises using 7/8" diameter hitch pins.
4. Secure the tractor's top link to the tiller top hitch using a 3/4" diameter hitch pin (supplied by customer). Adjust tractor top link in order to level the tiller.
5. Adjust the tractor's 3-Point hitch lift height so that the tiller tines are not lifted more than 14" off the ground to prevent damage to the driveline u-joints.

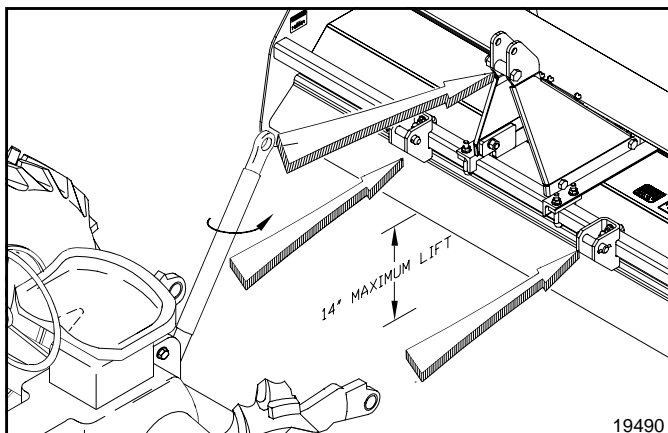

Tractor Hook-Up
Figure 1-2

Driveline Installation

Refer to Figure 1-3, Figure 1-4 & Figure 1-5:

The tiller driveline is coupled to the tractor and implement shafts with either push pin couplers, pull collar couplers or a combination of both and with either a shear bolt or slip clutch on one end for protection from shock loads.

Always engage the PTO at low engine rpm to minimize start-up torque on the driveline. Drivelines with friction clutches must go through a "run-in" operation prior to initial use and after long periods of inactivity. See "Section 4: Maintenance and Lubrication" on page 14 for a detailed description of maintaining the driveline.

CAUTION

Tractor PTO shield and all tiller guards must be in place at all times during operation!

1. Slide driveline end with friction clutch or shear bolt device over splined shaft of the gearbox and secure with locking device of driveline.
2. Slide driveline over the tractor's splined PTO shaft and secure with locking device of driveline. Skip to step 4 if driveline fits between tractor and implement.

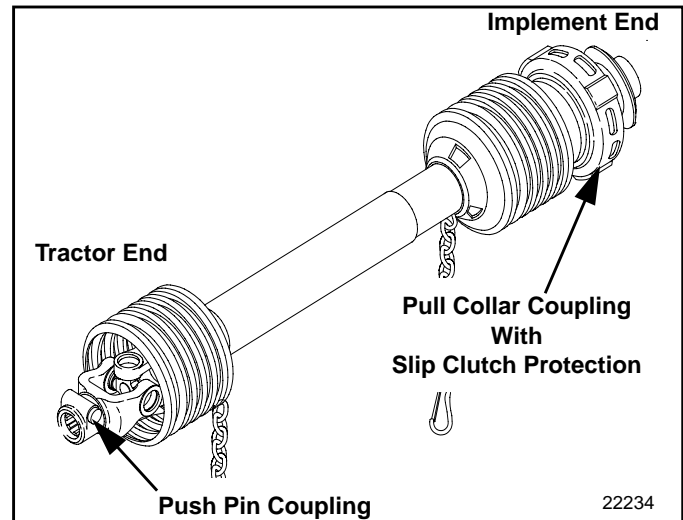

Figure 1-3

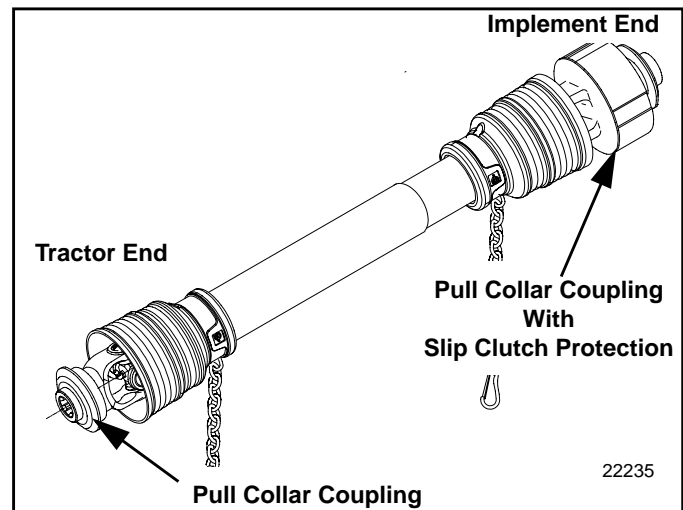

Figure 1-4

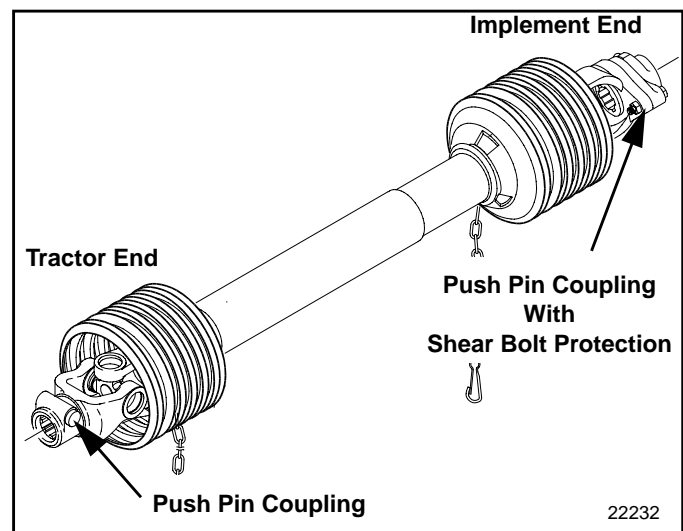

Figure 1-5

Section 1: Assembly and Set-Up

Refer to Figure 1-6:

3. The driveline will require shortening if it is too long to fit between the tractor and tiller gearbox. Shorten driveline as follows:
 - a. Set tractor in park, shut tractor engine off, set park brake and remove switch key.
 - b. Pull driveline apart into two sections as shown in Figure 1-6. Attach the outer driveline universal joint to the tractor shaft and inner driveline universal joint to the tiller gearbox shaft. Pull on each driveline section to be sure the universal joints are secured to the shafts.
 - c. Hold the driveline sections parallel to each other to determine if they are too long. The inner and outer shields on each section should end approximately 1" short of reaching the universal joint shield on the adjacent section (see "B" dimension). If they are too long, measure 1" ("B" dimension) back from the universal joint shield and make a mark at this location on the inner and outer driveline shields.
 - d. Cut off the inner shield at the mark ("X" dimension). Cut the same amount off the inner shaft ("X1" dimension). Repeat cut off procedure ("Y" & "Y1" dimensions) to the outer driveline half.
 - e. Remove all burrs and cuttings.
 - f. Apply multi-purpose grease to the inside of the outer shaft and reassemble the driveline.
 - g. Attach inner driveline yoke end to the tiller divider gearbox input shaft.
 - h. Attach outer driveline yoke end to the tractor's shaft.
4. Move the driveline back and forth to insure that both ends are secured to the tractor and tiller shafts. Reattach any end that is loose.

IMPORTANT: Two small chains are supplied with the driveline. These chains must be attached to the driveline shields and to the rotary tiller and tractor to restrict the shields from rotating.

5. Hook driveline safety chain at the tiller to the top hole located in the front flange of the tiller hitch. Re-latch safety chain to driveline guard.
6. Hook driveline safety chain at the tractor to the tractor pull tongue. Re-latch safety chain to driveline guard.

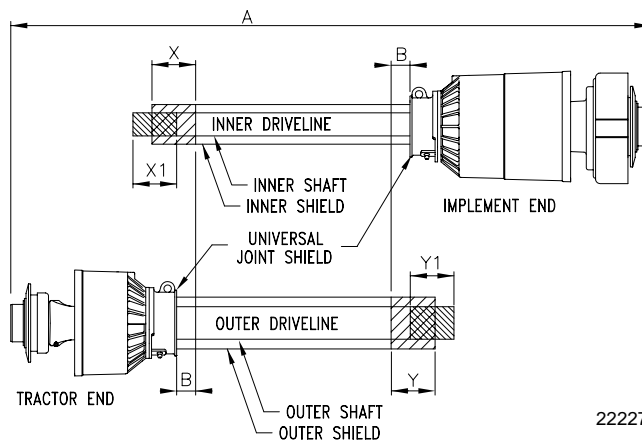

Cutting the Driveline Shafts
Figure 1-6



Section 2: Operating

Transporting

IMPORTANT: Always disengage PTO before raising the tiller to transport position.



CAUTION

When traveling on public roads whether at night or during the day, use accessory light and devices for adequate warning to operators of other vehicles. Comply with all federal, state and local laws.

1. When raising the tiller to the transport position, be sure that driveline does not contact tractor or tiller. Adjust the tractor's 3-point hitch lift height so that the tiller tines are not lifted more than 14 inches off the ground to prevent damage to the driveline.
2. Be sure to reduce tractor ground speed when turning; and, leave enough clearance so the tiller does not contact obstacles such as buildings, trees or fences.
3. Select a safe ground travel speed when transporting from one area to another. When traveling on roadways, transport in such a way that faster moving vehicles may pass you safely.
4. When traveling over rough or hilly terrain, shift tractor to a lower gear.

Parking

The following steps should be taken when preparing to store the tiller or unhitch it from the tractor. Also see *Storage* in the "Maintenance and Lubrication" section starting on page 17 for additional information on long term storage of your tiller.

1. Park the tiller on a level, solid area.
2. Shut off tractor engine and engage parking brake.
3. Set parking stand to desired height for re-hook-up and install pin to lock in place.
4. Unhitch from tractor.
5. See *Storage* in the "**Maintenance and Lubrication**" section on page 17 if tiller is not going to be used for a long period.

General Notes for Field Operations

Before beginning to till the following inspection should be performed:

1. Check oil level in gearbox and chaincase. Refer to *Lubrication* in the "**Maintenance and Lubrication**" section starting on page 14.
2. Check that all plugs have been replaced properly in the gearbox and chaincase.
3. Check drive chain tension. Refer to *Drive Chain* in the "**Adjustment**" section on page 13.
4. Be sure all tiller tines, bolts and nuts are tight.
5. Be certain all guards and shields are in place and secure.

6. Grease driveline shaft and all other grease fittings.
7. Clear the area to be tilled of rocks, branches and other foreign objects.
8. Tall grass and weeds may need to be mowed before tilling.
9. Operate with 540 rpm PTO tractor.
10. At first begin tilling at a slow forward speed and shift up as ground conditions warrant.
11. Tiller should be operated with the tiller deck level to the ground.
12. Tiller tines will cut better at a faster rotor speed than at reduced throttle.
13. Do not engage PTO at full throttle.
14. Tilling should not be done in wet conditions as soil will stick to tines.
15. After tilling the first 50 feet, stop and check to see that the tiller is adjusted properly.
16. Do not make turns or attempt to back up while tiller is in the ground. See important note below.

IMPORTANT: Turning or backing up with rotary tines in the ground will damage the tiller.

17. Do not engage PTO with machine in the fully raised or lowered position.
18. Periodically check for foreign objects wrapped around the rotor shaft and remove them after disengaging PTO, turning off tractor, and removing ignition key.

Operating Check List

In addition to design and configuration of equipment, hazard control and accident prevention are dependent upon the awareness, concern, prudence and proper training involved in its operation, transport, maintenance and storage of equipment. Before beginning to operate your Rotary Tiller, the following inspection should be performed.

Operating Checklist		
✓	Check	Reference
	Read "Important Safety Information"	Page 1
	Read all of the <i>Tractor Hook-Up</i> and preparation instructions.	Page 9
	Read " Operating Instructions "	Page 11
	Lubricate the tiller as needed. Refer to <i>Lubrication</i> .	Page 18
	Check the tiller initially and periodically for loose bolts & pins, <i>Torque Values Chart</i> .	Page 23
	Make sure all guards and shields are in place.	Page 11
	Check initially and periodically for loose bolts, pins, and chains.	Page 11

Section 2: Operating

Operating Instructions

Before using your Land Pride RTA20 Series Rotary Tiller, you should have completely read the Operator's Manual, properly attached the Tiller to the tractor, cut the Drive-line to proper length, Run-in the clutch, and gone through the Operating Checklist. If you have missed any of these steps, please complete them before proceeding.

Now that you have properly prepared yourself and your tiller, it's time to do some tilling. Carefully drive the tractor to the site where you intend to till. You should have already cleaned this site of any large limbs, rocks, trash, metal or extraneous debris. Best results will be achieved if you have mounted your tiller offset to the left far enough to cover the tread of your left tractor wheel. Line the tractor up just to the right of center on your tillage plot. You will be working from the center out and always turning to the left to line up for your next pass. Lower the tiller half way to the ground and reduce your tractor engine speed to about one quarter throttle. Engage the PTO and gradually increase the engine speed until you reach full PTO speed of 540 rpm. Lower the Tiller to the ground and simultaneously commence forward travel of approximately 2 mph. Do not make turns or attempt to back up while tiller is in the ground. See important note below.

IMPORTANT: Turning or backing up with rotary tines in the ground will damage the tiller.

Travel about 50ft. and then stop to check your results. When stopping, remember to lift the tiller out of the ground, stop the tractor, reduce engine speed, disengage the PTO, set the park brake, shut off the tractor, and remove the keys. If you are tilling too shallow or too deep, adjust the skid shoes accordingly. If the soil texture is too coarse, lower the leveling door and reduce your ground speed. If the soil texture is too fine, you will need to raise your leveling door and increase your ground speed. For any other problem conditions that may arise, you will want to refer to the Troubleshooting section of this Operator's Manual.

When you are done tilling for the day, make sure you use proper tractor shut down procedures before you get off of the tractor. If you are detaching your tiller, make sure you park it on a dry and level surface leaving it clean and ready for the next use. When you put your tiller up for the season, make sure you refer to the Storage Directions in this Operator's Manual.

With a little practice and a few adjustments, you will soon be achieving the results you want with your Land Pride Rotary Tiller. See "**Features and Benefits**" page 21 or "**Specifications and Capacities**" page 20 for additional information and performance enhancing options.

Section 3: Adjustments

Drive Chain

Refer to Figure 3-1:

The tension on the drive chain can be easily adjusted by using the chain tightener stud.

Should excessive backlash occur, unscrew the lock nut, turn the bolt, Figure 3-1, clockwise as indicated by the arrow, until idler arm is firm against chain, then back the bolt off counterclockwise 1/4" turn. Re-lock the lock nut while holding the head of the bolt in place. Refer to the *Torque Values Chart* in the "Appendix" section on page 23.

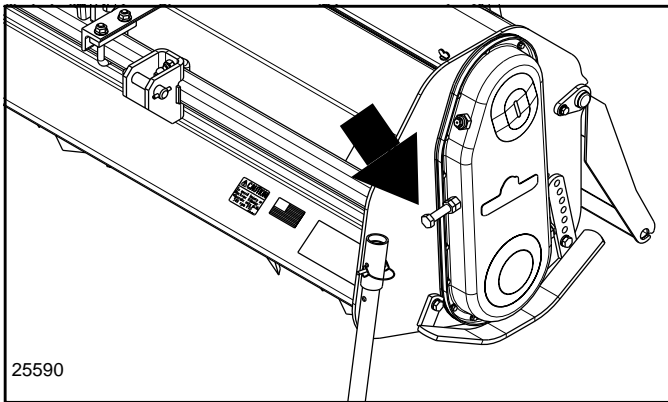

Chain Tightener
Figure 3-1

Rear Deflector & Down Pressure Kit

The rear deflector can be adjusted closer to the ground to produce a fine soil texture or can be raised to produce a coarse soil texture by adjusting the spring rods. Adjust rear deflector to the desired height and install cotter pins in one of the top six holes on the spring rods above the cushion springs Figure 3-3.

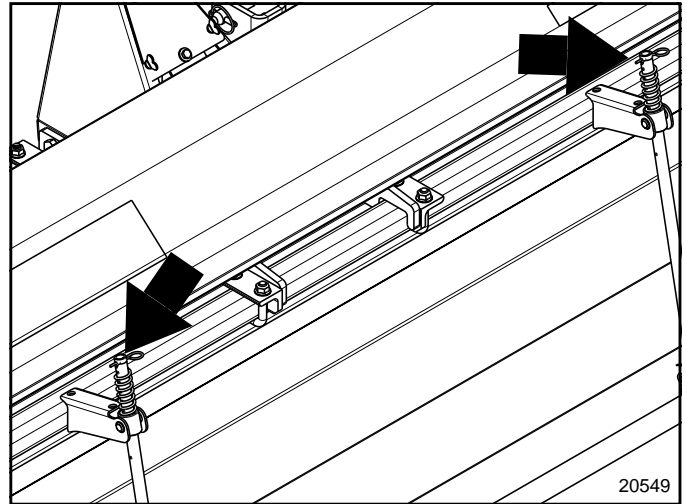

Rear Deflector
Figure 3-3

Skid Shoe

Refer to Figure 3-2

The skid shoes can be raised or lowered for the desired tilling depth by:

1. Raise tiller off the ground and properly support.
2. Loosen pivot bolt on front of shoe.
3. Remove adjusting bolt on rear of shoe.
4. Adjust skid shoe to desired location.
5. Install adjusting bolt, and tighten both the adjusting bolt and the pivot bolt.

IMPORTANT: Be sure both skid shoes are adjusted the same.

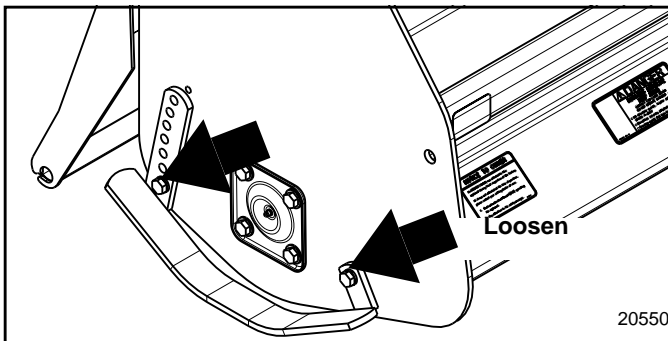

Skid Shoe Adjustment
Figure 3-2

The rear deflector can be raised and secured for replacement of spring tines by removing the cotter pins and raising the deflector enough to reinstall the cotter pins in hole no. 7 on the spring rods below the cushion springs.

An optional spring kit, part no. 311-162A, is offered to allow you to apply pressure down on the rear deflector for leveling. Adjust locking collars up to compress springs to desired pressure.

NOTE: Too much pressure will cause premature wear on the rear deflector.

Section 4: Maintenance and Lubrication

Maintenance

CAUTION

For safety reasons, each maintenance operation must be performed with the tractor's PTO disengaged, the Tiller lowered completely to the ground or on safely supported blocking, tractor engine shut off and ignition key removed.

Proper servicing and adjustment can increase the life of any implement. With careful and systematic inspection, you can avoid costly maintenance, time and repair.

After using your tiller for several hours, check all bolts to be sure they are tight.

Replace any worn, damaged or illegible safety labels by obtaining new labels from your Land Pride Dealer.

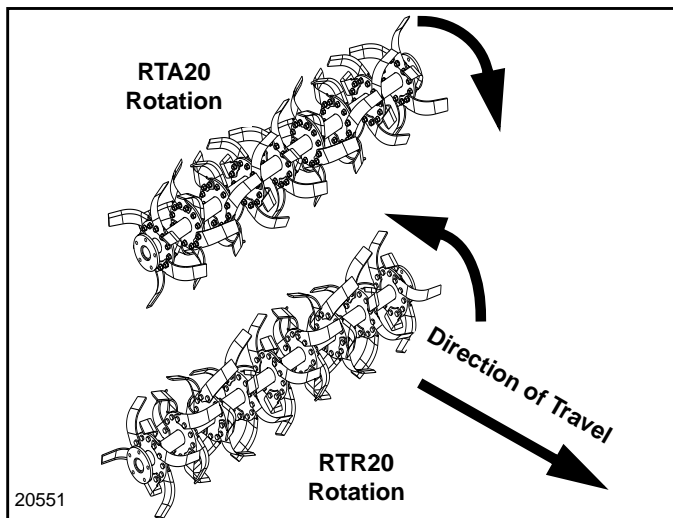

Tine Replacement
Figure 4-1

Tine Replacement

Refer to Figure 4-1:

WARNING

Worn tines may be very sharp!

IMPORTANT: Always install tine with cutting edge facing direction of rotor shaft rotation. When ordering replacement tines, be sure to order both right and left hand tines.

1. Remove 2 bolts and nuts from tine to be replaced. Remove tine.
2. Install new tine on side of attaching flange.
3. Replace 2 bolts and nuts and tighten nuts to proper torque. See the *Torque Values Chart* in the "Appendix" section on page 23.

IMPORTANT: Replace tines with genuine Land Pride tines only.

Driveline Protection

Driveline components are protected from shock loads by a friction slip clutch. The clutch must be capable of slippage during operation to protect the gearbox, driveline and other drive train parts.

Friction clutches should be "run-in" prior to initial operation and after long periods of inactivity to remove any oxidation that may have accumulated on the friction surfaces. Repeat "run-in" instructions at the beginning of each season and when moisture and/or condensation seizes the inner friction plates.

Refer to Figure 4-2 below and Figure 4-3 on page 16 to determine which friction clutch your Rotary Tiller has. Follow run-in, disassembly and assembly instructions for your specific clutch.

Clutches With 4 Adjusting Nuts

Clutch Run-In

Refer to Figure 4-2 (View - A):

1. Using a pencil or other marker, scribe a line across the exposed edges of the clutch plates and friction disks.
2. Tighten all 4 nuts uniformly until spring load is low enough that the clutch slips freely with PTO engaged.

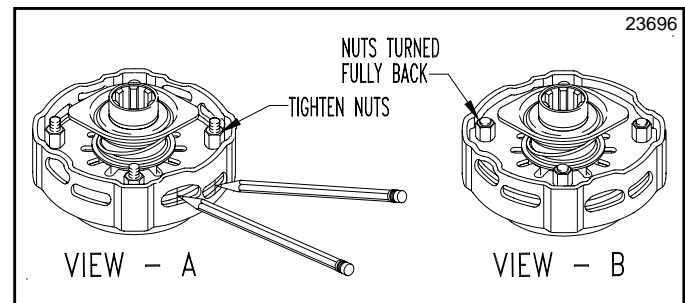

Clutches With 4 Adjusting Nuts
Figure 4-2

3. Start tractor and engage PTO for 2-3 seconds to permit slippage of clutch surfaces. Disengage PTO, then re-engage a second time for 2-3 seconds. Disengage PTO, shut off tractor and remove key. Wait for all components to stop before dismounting from tractor.
4. Inspect clutch and ensure that the scribed markings made on the clutch plates have changed position. Slippage has not occurred if any two marks on the friction disk and plate are still aligned. A clutch that has not slipped must be disassembled to separate the friction disk plates. See Clutch Disassembly & Assembly on page 15.

Refer to Figure 4-2 (View - B):

5. Turn all 4 nuts fully back if no two marks on the friction disk and plate are still aligned. Clutch is ready for use.
6. The clutch should be checked during first hour of cutting and periodically each week. An additional set of scribe marks can be added to check for slippage.

Section 4: Maintenance and Lubrication

Clutch Disassembly & Assembly

If clutch run-in procedure indicates that one or more of the friction disks did not slip, then the clutch must be disassembled to separate the friction disks.

NOTE: Before proceeding, secure clutch firmly in a vise or other clamping device to prevent injury.

Disassembly

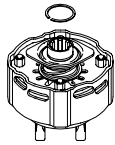

◀ **Step 1**
Remove snap ring.

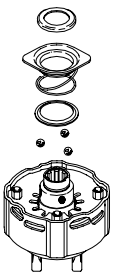

◀ **Step 2**
Remove backup ring, lock collar, compression spring, bottom backup ring, and balls.

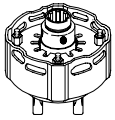

◀ **Step 3**
Tighten the four hex nuts uniformly until the clutch pack and hub are loose.

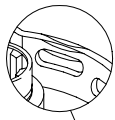

◀ **Step 4**
Bend all four retaining lugs out on the edge of the clutch housing.

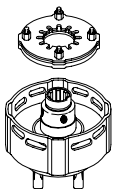

◀ **Step 5**
Remove the thrust plate with the Belleville Springs and lug rings to access friction disks and hub for inspection or service.

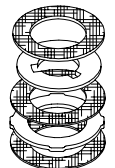

◀ **Step 6**
Inspect friction disks and hub.

14232

Assembly

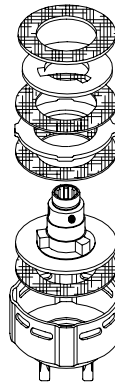

◀ **Step 1**
Place the hub and friction disks into the housing.

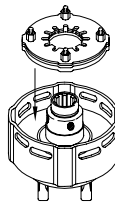

◀ **Step 2**
Compress the Belleville Springs to the pressure plate by tightening the four hex nuts and then placing the assembly into the clutch housing.

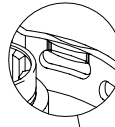

◀ **Step 3**
Bend the retaining lugs inward over the Belleville Spring edges to secure the spring before backing the four hex nuts off.

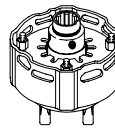

◀ **Step 4**
With the lugs bent in, loosen the four hex nuts completely to the end of the threaded studs.

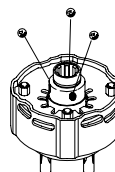

◀ **Step 5**
Insert greased balls.

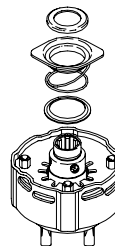

◀ **Step 6**
Install bottom backup ring, compression spring, lock collar, and top backup ring.

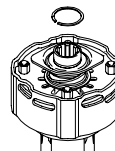

◀ **Step 7**
Install snap ring.

14233

Section 4: Maintenance and Lubrication

Clutches With 8 Hex Socket Bolts

Clutch Run-In

Refer to Figure 4-3:

1. Loosen counterclockwise all 8 hex head socket bolts uniformly 6 full turns.
2. Cycle clutch on and off 5 or 6 times (15 seconds on and 15 seconds off) with the engine operating at half throttle. Disengage driveline, shut off tractor and remove key. Wait for all components to stop before dismounting from tractor.
3. Tighten hex head socket bolts fully back. Clutch is ready for use
4. The clutch should be checked during the first hour of cutting and periodically each week.

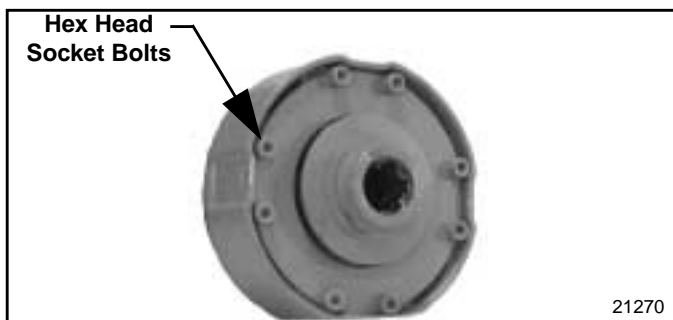

Clutch Run-In With 8- Hex Head Socket Bolts
Figure 4-3

Clutch Disassembly & Assembly

Refer to Figure 4-4:

If clutch run-in procedure above indicated that one or more friction disks did not slip, then the clutch must be disassembled into separate friction disks.

1. Rotate 8 Alan head socket bolts (#2) all the way out to free stop flange (#3).
2. Record position of the lips (up or down) on stop flange (#3) and then rotate flange and remove it.
3. Remove the following inner components:
 - a. Spring kit (#4)
 - b. Pressure flange (#5)
 - c. 1st Friction Disc (#6)
 - d. Hub with flange and pull collar (#7 & #1)
 - e. 2nd Friction disc (#6)
 - f. Intermediary flange (#8)
 - g. 3rd Friction disc (#6)
 - h. Hub disc (#9)
 - i. 4th Friction disc (#6)
 - j. Bearing (#10)
4. Inspect all components and replace to their original position. Make certain stop flange (#3) is replaced with its flanges down as shown.
5. Fully tighten all 8 Alan head socket bolts (#2).

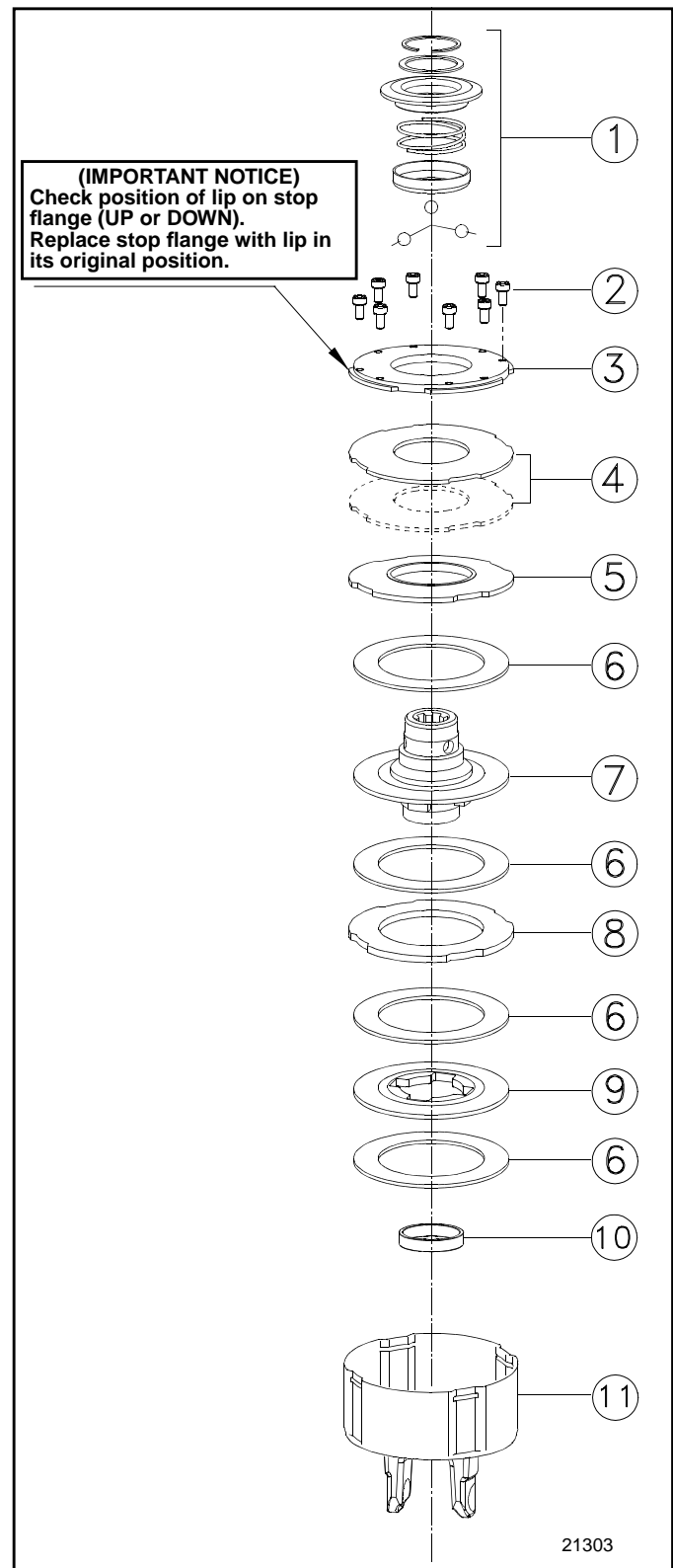

Clutch Assembly
Figure 4-4

Section 4: Maintenance and Lubrication

Storage

At the end of the working season or when the tiller will not be used for a long period, it is good practice to clean off any dirt or grease that may have accumulated on any of the moving parts.

Check the tines for wear and replace if necessary. See *Tine Replacement* earlier in this section.

Inspect the tiller for loose, damaged or worn parts and adjust or replace if needed.

Lubricate as noted in *Lubrication* starting on page 18.





Repaint parts where paint is worn or scratched to prevent rust.

Drain gearbox and chaincase oil. Drain oil in gearbox by removing the bottom drain plug or right hand cap. Drain oil in chaincase by removing the bottom plug and tipping tiller backwards. Be sure to refill gearbox and chaincase at this time.



Store tiller in a clean, dry place.

Section 4: Maintenance and Lubrication

Lubrication

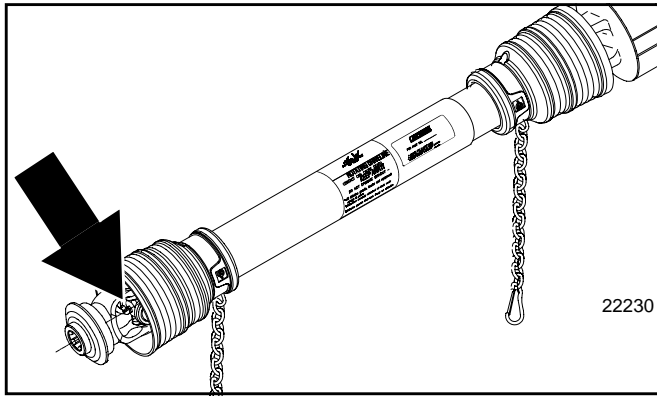
Lubrication Legend	 Multi-purpose spray lube	 Multi-purpose grease lube	 Multi-purpose oil lube	 20	Intervals in hours at which lubrication is required.



	 8 Hours
------------------------------------------------------------------------------------	---------------------------------------------------------------------------------------------



Driveline U-Joint (Both Ends)

Coat PTO u-joint with grease every 8 hours of operation.

Type of grease = Multi-Purpose

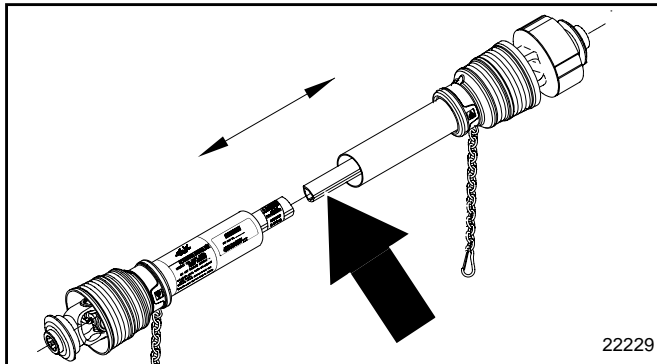
Quantity = Coat Generously



	 20 Hours
--------------------------------------------------------------------------------------	------------------------------------------------------------------------------------------------



Driveline Shaft

Disconnect Driveline from the tractor and slide apart. Clean and coat the inner tube of the Driveline shaft with a light film of grease and then reassemble.

Type of grease = Multi-Purpose

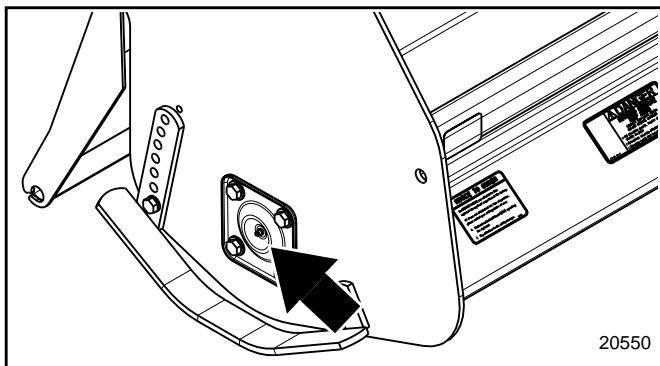
Quantity = Coat Generously



	 8 Hours
--------------------------------------------------------------------------------------	-----------------------------------------------------------------------------------------------

Bearing on Right End of Rotor Shaft

Grease bearing on right end of rotor shaft until grease starts to purge from the relief hole in the bearing mount casting on the inside of the tiller end plate.

Type of grease = Multi-Purpose

Quantity = Coat Generously

Section 4: Maintenance and Lubrication

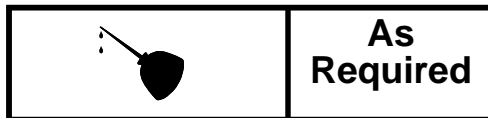
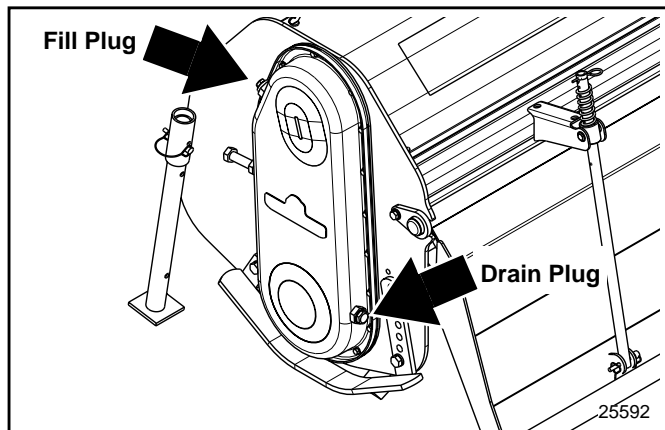

Chaincase

With tiller on level ground, check oil level in chaincase by removing lower plug. Oil should reach the plug hole. Fill if necessary with Shell Alvania EP00 oil and retighten plug. Tiller should be level when checking.

Type = Recommended: Shell Alvania EP00 Oil
 Alternate: SAE 90 wt. oil

Quantity = As required

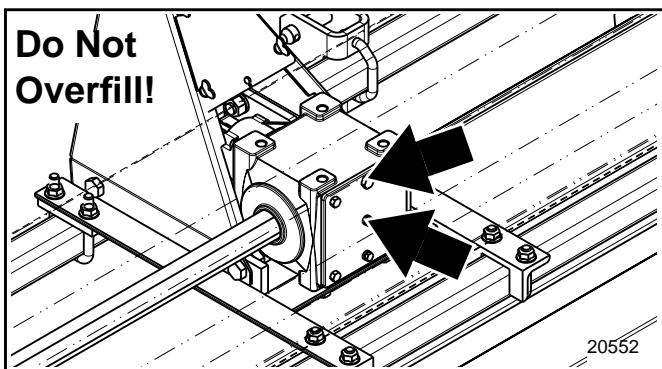

Gearbox

Check the oil level in the gearbox by removing the plug located in the center of rear cover. Fill if necessary with SAE 90 oil and retighten both plugs.

IMPORTANT: Should your gearbox require repair, take it to your Land Pride Dealer! Check the oil level in the gearbox at least every 50 hours of operation.

Type of lubrication = SAE 80-90W EP Oil

Quantity = As required



RTA20 & RTR20 Series				
Model	RTA2064	RTR2064	RTA2072	RTR2072
Weight	689 lbs.	748 lbs.	734 lbs.	795 lbs.
Tilling Width	64"		72"	
Overall Width	70 1/4"		77 5/16"	
Offset Capabilities	14"		18"	
Number of Flanges	8		9	
Number of Tines per Flange	6			
PTO Driveline	ASAE Category III Heavy Duty Friction Clutch or Shear Bolt			
Gearbox	40 HP Input at 540 rpm 1.92:1 Ratio Cast Iron Housing, Straight Bevel Gears			
Gearbox Lubrication	SAE80-90W EP oil			
Drive Chain	#80 roller chain in flowable grease bath			
Drive chain lubricant	Shell Alvania EP 00 or equivalent			
Sprockets	Splined Bores			
Rotor Swing Diameter	17"			
Rotor Shaft Speed	220 rpm at 540 rpm PTO			

Section 6: Features & Benefits

RTA20 & RTR20 Series

Features	Benefits
20 Series	Fills the gap between our 15 and 25 Series Tillers, both in size and price.
Tractor HP	23 - 40 HP.
Gearbox Warranty	3 Years on housing, gears, shafts & seals. Shows our confidence in the product.
Working Widths	64" & 72" Meets a wide range of customer needs.
Formed Deck	Handles material more efficiently, sheds water.
Integral Hitch	Upper hitch, gearbox and gearbox mount brought together to form a stronger overall hitch frame.
Clevis Style Lower Hitch	Allows easier hook-up of lower 3-point arms.
Cat. 1 Hitch fits Land Pride Quick-Hitch	Allows for quick and easy one-person hook-up. Offset is not comparable with Quick-Hitch.
RTR Reverse rotation model or RTA forward rotation model	Land Pride has the market on reverse rotation. This brings in a quality tiller at a more affordable price for landscapers. We offer forward rotation for contractors who want it.
Reverse tilling action	Reverse action 'sucks' tiller into ground, does not walk on top of hard ground like forward rotation tillers can.
Sideshift capability	Sideshifts by loosening 6 U-bolts and sliding hitch points and gearbox over. Allows covering right tire track.
Parking Stand	Allows for easy hook-up and storage
Six tines standard on RTR20 Four tines standard on RTA20 with six being optional	Six tines cut through the ground smoother.
C Tines	C Tines take less horsepower to move through the ground.
17" Rotor swing diameter	For deep tilling action.
Double lip seal on rotor bearing	Double lip seal keeps the dirt out and the grease in.
#80 Drive chain enclosed in oil bath	Heavy-duty drive chain reduces stretching. Oil keeps constant lubrication and holds wear to a minimum.
Easy to adjust chain tightener	Cast iron chain tightener is a simple bolt adjustment to keep constant tension on the chain.
Stamped chain cover	Stamped forming adds additional strength.
Adjustable skid shoes	Control depth from various settings.
Cat. 3 driveline with slip-clutch (option)	Heavy driveline for rough conditions. Slip-clutch protects other drive train components.
Material separator behind tilling action (RTR only)	3/8" Rods sift the material letting bigger items fall first. Sifted soil falls last burying the bigger items. Attachment is one all welded piece for easy assembly.
Formed rear deflector with springs	Formed steel gives the rear deflector additional strength. Springs allow deflector to bounce as it hits obstructions.

Problem	Cause	Solution
Machine makes intermittent clicking noise	Loose tines Gearbox tooth damaged Chain damaged	Tighten tines Replace damaged gear Replace damaged chain link
Driveline vibrates	Worn universal joint Excessive trash wrapped on rotor Machine lifted too high	Replace universal joint Remove trash Lower machine and readjust tractor lift stop
Gearbox noise is noticeable and constant	May be normal on new machine Low oil level Worn gears	Allow time for break-in Add oil Replace gears
Oil leaking from gearbox	Damaged seals or gaskets Gearbox overfilled	Replace seals or gaskets Drain to proper level
Rotor will not turn	PTO not engaged Broken drive chain Shearbolt broken on driveline Friction clutch slipping	Engage PTO Repair drive chain Replace shearbolt Reduce load to tiller
Tillage depth insufficient	Tiller carried by tractor Insufficient power Skid Shoes need adjusting Worn or bent tines Tines incorrectly installed Obstacles entangled in tines and/or rotor Lower hitch clevises on tiller in wrong position	Lower tractor 3-point arms Increase tractor rpm Adjust skid shoes Replace tines Check tine placement Clear rotor and/or tines Relocate lower hitch clevises
Soil texture too coarse	Leveling door too high PTO speed too slow Ground speed too fast	Lower leveling door Increase PTO speed Decrease ground speed
Soil texture too fine	Leveling door too low Ground speed too slow	Raise leveling door Increase Ground Speed
Machine skips or leaves crop residue	Badly worn tines Friction clutch slipping Ground speed too fast for conditions	Replace worn tines Reduce load Reduce ground speed
Tines balling up with soil	Worn or bent tines Tines incorrectly installed Rear deflector too low Tractor speed too fast Soil too wet	Replace tines Install tines correctly Raise rear deflector Decrease tractor speed Wait until soil dries
Tiller bumping on ground	Obstacles entangled in tines and/or rotor Tines not installed correctly	Clear rotor and/or tines Install tines correctly

Section 8: Appendix

Torque Values Chart													
Bolt Size (Inches)	Bolt Head Identification						Bolt Size (Metric)	Bolt Head Identification					
	Grade 2		Grade 5		Grade 8			Class 5.8		Class 8.8		Class 10.9	
in-tpi ¹	N · m	ft-lb ³	N · m	ft-lb	N · m	ft-lb	mm x pitch	N · m	ft-lb	N · m	ft-lb	N · m	ft-lb
1/4" - 20	7.4	5.6	11	8	16	12	M 5 X 0.8	4	3	6	5	9	7
1/4" - 28	8.5	6	13	10	18	14	M 6 X 1	7	5	11	8	15	11
5/16" - 18	15	11	24	17	33	25	M 8 X 1.25	17	12	26	19	36	27
5/16" - 24	17	13	26	19	37	27	M 8 X 1	18	13	28	21	39	29
3/8" - 16	27	20	42	31	59	44	M10 X 1.5	33	24	52	39	72	53
3/8" - 24	31	22	47	35	67	49	M10 X 0.75	39	29	61	45	85	62
7/16" - 14	43	32	67	49	95	70	M12 X 1.75	58	42	91	67	125	93
7/16" - 20	49	36	75	55	105	78	M12 X 1.5	60	44	95	70	130	97
1/2" - 13	66	49	105	76	145	105	M12 X 1	90	66	105	77	145	105
1/2" - 20	75	55	115	85	165	120	M14 X 2	92	68	145	105	200	150
9/16" - 12	95	70	150	110	210	155	M14 X 1.5	99	73	155	115	215	160
9/16" - 18	105	79	165	120	235	170	M16 X 2	145	105	225	165	315	230
5/8" - 11	130	97	205	150	285	210	M16 X 1.5	155	115	240	180	335	245
5/8" - 18	150	110	230	170	325	240	M18 X 2.5	195	145	310	230	405	300
3/4" - 10	235	170	360	265	510	375	M18 X 1.5	220	165	350	260	485	355
3/4" - 16	260	190	405	295	570	420	M20 X 2.5	280	205	440	325	610	450
7/8" - 9	225	165	585	430	820	605	M20 X 1.5	310	230	650	480	900	665
7/8" - 14	250	185	640	475	905	670	M24 X 3	480	355	760	560	1050	780
1" - 8	340	250	875	645	1230	910	M24 X 2	525	390	830	610	1150	845
1" - 12	370	275	955	705	1350	995	M30 X 3.5	960	705	1510	1120	2100	1550
1-1/8" - 7	480	355	1080	795	1750	1290	M30 X 2	1060	785	1680	1240	2320	1710
1 1/8" - 12	540	395	1210	890	1960	1440	M36 X 3.5	1730	1270	2650	1950	3660	2700
1 1/4" - 7	680	500	1520	1120	2460	1820	M36 X 2	1880	1380	2960	2190	4100	3220
1 1/4" - 12	750	555	1680	1240	2730	2010							
1 3/8" - 6	890	655	1990	1470	3230	2380							
1 3/8" - 12	1010	745	2270	1670	3680	2710							
1 1/2" - 6	1180	870	2640	1950	4290	3160							
1 1/2" - 12	1330	980	2970	2190	4820	3560							

¹ in-tpi = nominal thread diameter in inches-threads per in.
² N · m = newton-meters
³ ft-lb = foot pounds
⁴ mm x pitch = nominal thread diameter in millimeters x thread pitch

Torque tolerance + 0%, -15% of torquing values. Unless otherwise specified use torque values listed above.

Notes

Warranty

Land Pride warrants to the original purchaser that this Land Pride product will be free from defects in material and workmanship beginning on the date of purchase by the end user according to the following schedule when used as intended and under normal service and conditions for personal use.

Overall Unit and Driveline: One year Parts and Labor

Gearbox: 5 years Parts and Labor

Tines and Driveline Friction Discs: Considered wear items

This Warranty is limited to the replacement of any defective part by Land Pride and the installation by the dealer of any such replacement part, and does not cover common wear items such as blades, belts, tines, etc. Land Pride reserves the right to inspect any equipment or parts which are claimed to have been defective in material or workmanship.

This Warranty does not apply to any part or product which in Land Pride's judgment shall have been misused or damaged by accident or lack of normal maintenance or care, or which has been repaired or altered in a way which adversely affects its performance or reliability, or which has been used for a purpose for which the product is not designed. Misuse also specifically includes failure to properly maintain oil levels, grease points, and driveline shafts.

Claims under this Warranty must be made to the dealer which originally sold the product and all warranty adjustments must be made through such dealer. Land Pride reserves the right to make changes in materials or design of the product at any time without notice.

This Warranty shall not be interpreted to render Land Pride liable for damages of any kind, direct, consequential, or contingent to property. Furthermore, Land Pride shall not be liable for damages resulting from any cause beyond its reasonable control. This Warranty does not extend to loss of crops, any expense or loss for labor, supplies, rental machinery or for any other reason.

No other warranty of any kind whatsoever, express or implied, is made with respect to this sale; and all implied warranties of merchantability and fitness for a particular purpose which exceed the obligations set forth in this written warranty are hereby disclaimed and excluded from this sale.

This Warranty is not valid unless registered with Land Pride within 30 days from the date of purchase by the end user.



Corporate Office: P.O. Box 5060
Salina, Kansas 67402-5060 USA
www.landpride.com

Free Manuals Download Website

<http://myh66.com>

<http://usermanuals.us>

<http://www.somanuals.com>

<http://www.4manuals.cc>

<http://www.manual-lib.com>

<http://www.404manual.com>

<http://www.luxmanual.com>

<http://aubethermostatmanual.com>

Golf course search by state

<http://golfingnear.com>

Email search by domain

<http://emailbydomain.com>

Auto manuals search

<http://auto.somanuals.com>

TV manuals search

<http://tv.somanuals.com>