

Lucent Technologies  
Bell Labs Innovations



SPIRIT<sup>®</sup>  
Communications System  
Model 308/616  
Customer Installation Instructions

999-500-226  
105772578  
Issue 4  
June 1989

Intellectual property related to this product and registered to AT&T Corporation has been transferred to Lucent Technologies Incorporated.

Any references within this text to American Telephone and Telegraph Corporation or AT&T should be interpreted as references to Lucent Technologies Incorporated. The exception is cross references to books published prior to December 31, 1996, which retain their original AT&T titles.

Lucent Technologies – formed as a result of AT&T's planned restructuring – designs, builds, and delivers a wide range of public and private networks, communication systems and software, consumer and business telephone systems, and microelectronic components. The world-renowned Bell Laboratories is the research and development arm for the company.

**INTERFERENCE INFORMATION  
FCC REGULATIONS PERTAINING TO THIS EQUIPMENT  
NOTICE**

**Federal Communications Commission (FCC) rules require that you be notified of the following:**

**FCC (Part 15)**

This equipment generates, uses, and can radiate radio frequency energy and, if not installed and used in accordance with the instructions in the installation, administration and user manuals may cause interference to radio and television communications.

This equipment has been tested and found to comply with the limits for a Class A computing device, pursuant to Subpart J of Part 15 of FCC Rules, which are designed to provide reasonable protection against such interference when operated in a commercial environment.

Operation of this equipment in a residential area may cause interference with nearby radios or television, in which case the owners (at their expense) will be required to take whatever measures may be necessary to correct the interference.

**FCC (Part 68)**

This equipment is registered with the Federal Communications Commission (FCC) in accordance with Part 68 of its Rules. The FCC requires that the manufacturer provides you with the following information:

**1. CONNECTION AND USE WITH THE NATIONWIDE TELEPHONE NETWORK**

The FCC requires that you connect your telephone equipment to the nationwide telephone network through a standard telephone network interface jack such as a USOC RJ11C.

Registered equipment may not be used with Coin Telephone Lines. Equipment may be used with Party Lines in areas where state tariffs permit such connections and when equipment is adaptable for such use.

**2. INFORMATION FOR THE TELEPHONE COMPANY**

Upon request of your local telephone company, you are required to provide them with the following information:

A. The lines to which you will connect the telephone equipment.

B. The FCC registration number, AS593M-72132-KF-E, and ringer equivalence number (REN), 0.3A/0.5B. Both numbers are on the controller. The REN is useful to determine how many devices you may connect to your telephone line and still have them ring when your telephone line is called. In most, but not all areas, the sum of all REN's per line should be 5 or less.

You may want to contact your local telephone company for specific information.

The local telephone company must also be notified upon final disconnection of the equipment from the local telephone company lines.

**3. REPAIR INSTRUCTIONS**

If it is determined that your telephone equipment is malfunctioning, the FCC requires that it not be used and that it be unplugged from the modular outlet until the problem has been corrected. Repairs to this equipment can be made only by the manufacturer or its authorized agents. For repair procedures, follow the instructions outlined under the AT&T Limited End User Warranty.

**4. RIGHTS OF THE TELEPHONE COMPANY**

If telephone equipment is causing harm to the telephone network, the telephone company may temporarily discontinue your telephone service. If possible, they will notify you before they interrupt service. If advance notice is not practical, you will be notified as soon as possible. You will be given the opportunity to correct the problem, and you will be informed of your right to file a complaint with the FCC.

Your telephone company may make changes in its facilities, equipment, operations, or procedures that could affect the proper functioning of your equipment. If such changes are planned, you will be notified.

**5. THIS EQUIPMENT IS COMPATIBLE WITH INDUCTIVELY COUPLED HEARING AIDS.**

## TABLE OF CONTENTS

Introduction	2
Overview of System	2
<b>Step 1 Plan Your System</b>	<b>3</b>
<b>Step 2 Check Outlet Grounding</b>	<b>3</b>
<b>Step 3 Mount Controller</b>	<b>4</b>
Mount Controller on Wall	4
Test the Incoming Telephone Lines	5
Connect Telephone Lines to Controller	5
<b>Step 4 Wiring Runs</b>	<b>6</b>
<b>Business (4-pair) Wiring</b>	<b>7</b>
Mount Jack Panel Boxes	8
Run Cable to All Telephone Locations	9
Install Modular Connecting Blocks	10
<b>Using Customer Convenience Wiring</b>	<b>12</b>
Install Plugs	12
Install Wire Junctions	12
Secure Telephone Wire	12
Install Modular Connecting Blocks	12
<b>Steps 5 Install Telephone Sets</b>	<b>14</b>
Record Installation Date	14
Desk Mount	14
Wall Mount	14
Label Intercom Extension Number	14
<b>Step 6 Connect System To Wiring Runs</b>	<b>15</b>
<b>Testing The System</b>	<b>15</b>
Testing the Incoming Telephone Company Lines	15
Testing the Wiring Run	15
Self Test	15
Controller Test	16
Telephone Test	17
<b>Troubleshooting</b>	<b>17</b>
<b>Optional Accessories</b>	<b>17</b>
<b>Replacement Parts</b>	<b>17</b>

*NOTICE: While reasonable efforts were made to ensure that the information in this document was complete and accurate at the time of printing, AT&T assumes no responsibility for any errors. Changes or corrections to the information contained in this document may be incorporated into future re-issues.*

## Introduction

This instruction manual will show you how to install your **SPiRiT** Communications System. Please read the instructions carefully before beginning installation.

## Overview of System

### What You Should Find in the Boxes

#### With the Controller:

controller  
three 7' line cords  
system directory label  
cord labels  
Administration Manual  
Customer Installation Instructions

#### With the Sets:

telephone set  
14' telephone cord  
designation labels/plastic strips  
User Manual  
Reference Card

*If your network interface jack has two lines on a single jack you should purchase a 267D adapter from your AT&T Phone Center store. If you need longer line and telephone cords, you should purchase them also.*

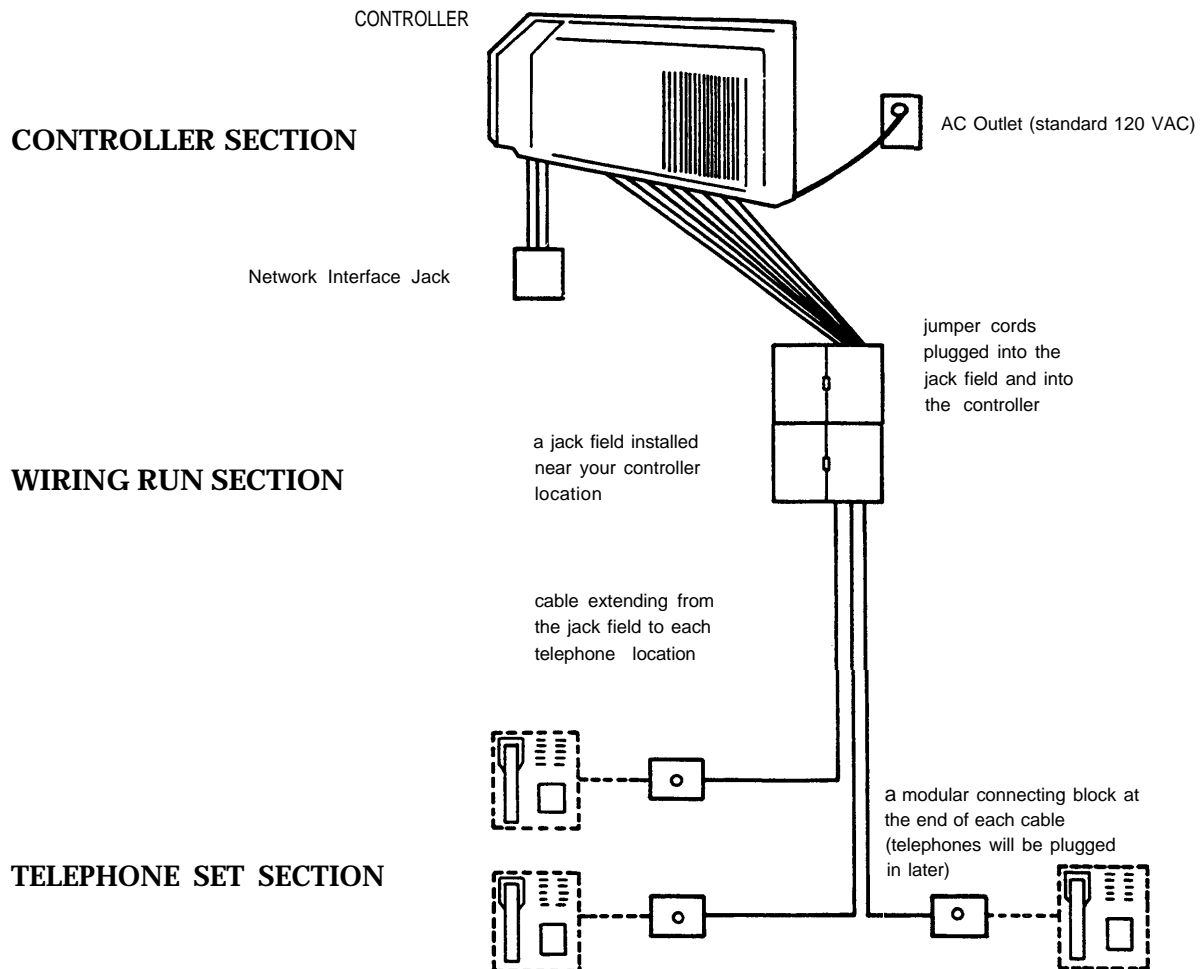

## Step 1 Plan Your System

Draw a floor plan of your business, showing the location of the network interface jacks, where your local telephone lines come into the building. You will want to install your controller close to these jacks.

Show on the floor plan the location of each telephone in your system. Also show the distances of the cable run from the controller to each telephone location.

Below is a sample floor plan to guide you in making your floor plan.

*NOTE: If you need to install SPIRIT Communications System telephones in another building an in-range, out-of-building (IROB) protection device is required. Contact your AT&T representative and order part number 31304.*

### INCOMING TELEPHONE LINES

(also called Network Interface Jacks)

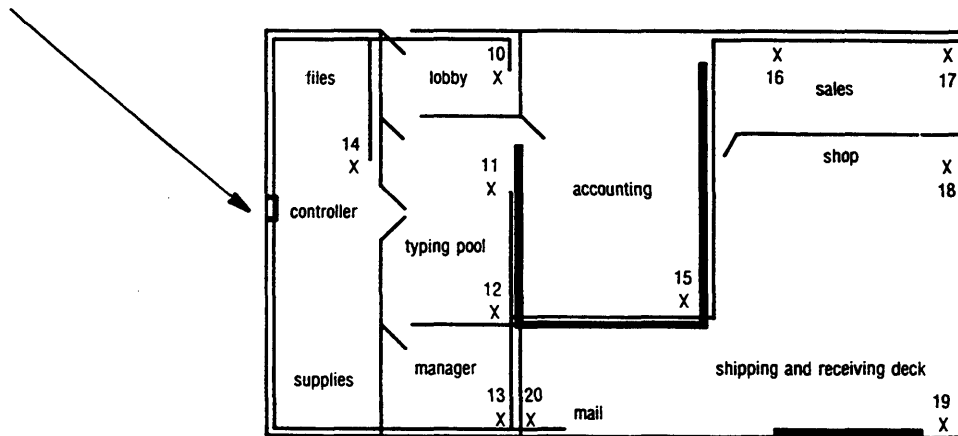

Set 10 30'	Set 14 30'	Set 18 150'
Set 11 40'	Set 15 85'	Set 19 170'
Set 12 50'	Set 16 120'	Set 20 100'
Set 13 60'	Set 17 135'	

*NOTE: Be sure cords do not cross walkways. Do not run cords inside or on top of air plenums and ducts or along hot pipes.*

## Step 2 Check Outlet Grounding

Your SPIRIT® Communications System control unit has been protected against AC line and central office line voltage surges caused by lightning strikes or other power anomalies, provided the system is properly grounded.

Using a circuit tester, check (or have checked by a qualified technician) the outlet into which your SPIRIT system control unit will be plugged. If the circuit tester detects any of the following faults, have them corrected before installation of the control unit:

- open ground
- reversed polarity
- open hot
- open neutral
- hot and ground reversed
- hot on neutral with hot open

If necessary, have a qualified electrician repair the electrical outlet in the manner specified by the applicable electrical codes to prevent service interruption and continue warranty protection. If you have two-wire outlets with no ground wire, a non-switched, three-wire grounded outlet should be installed.

### Step 3 Mount Controller

#### ■ Mount Controller on Wall

Choose a location within five feet of the network interface jacks, where the local telephone company lines enter the building, and near an AC outlet that is not controlled by a switch. Be sure the controller is in a well-ventilated area with a temperature range of 40°F to 100°F, and free of excess dust. The controller should be mounted a minimum of two feet from the floor with the modular connecting blocks positioned at the bottom.

Make a template like the one shown below. Using the template as a guide, install two of the four screws (not included) in the top, leaving  $\frac{1}{4}$ " protruding from wall. Do not install the bottom two screws until the controller is in place.

Install the controller, placing the two keyholes on the back of the controller against the screws in the wall and pulling the controller down.

Install the bottom two screws through the tabs on the controller and tighten firmly.

Write the date on one of the date installed (DATE INST:) labels, located on the cord labels, and place it on the side of the controller.

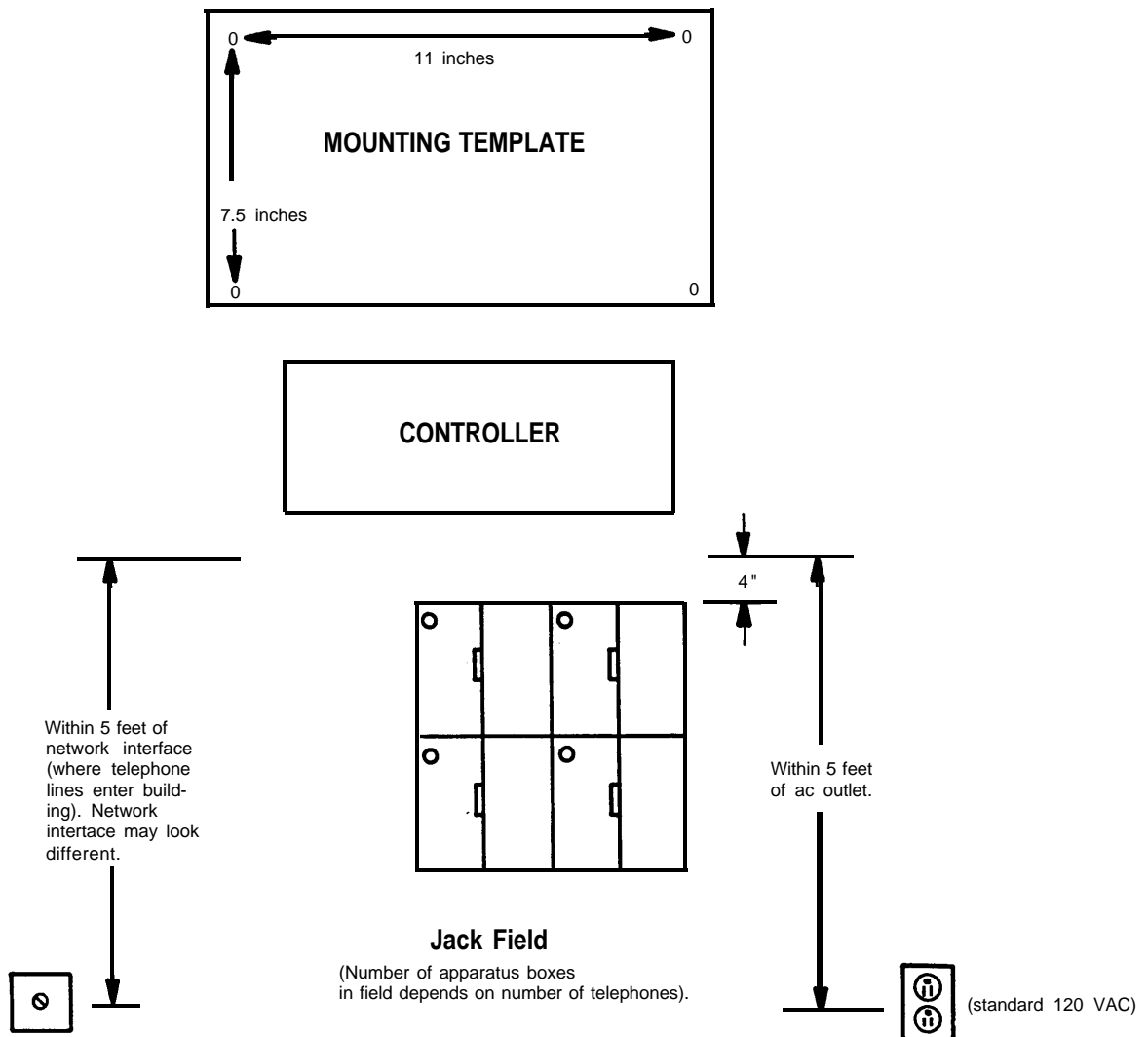

■ **Test the Incoming Telephone Lines.**

*TEST: If you have a standard telephone with a modular cord, plug it into each jack of the network interface, or incoming telephone lines. If these jacks do not work you will require service by your local telephone company.*

*When the telephone lines were installed, the phone number should have been marked on the network interface jack. If that was not done, write the telephone number on the jack. You may require help from your local telephone company to decide which jack is for what number.*

Some network interface jacks carry one line only, while some carry two. If your jacks are one-line jacks (RJ11-type network interface), you may connect the jack directly to the controller. If your jacks carry two lines (RJ14-type network interface), purchase a 267D 2-line adapter and a D4BU cord.

■ **Connect Telephone Lines to Controller.**

Remove from the controller box one line cord for each incoming telephone line. Additional cords and longer cords up to 25' long may be purchased at a phone store or from your AT&T representative. LABEL EACH END OF EACH CORD WITH A LINE CORD LABEL.

If your interface jack is a one-line jack (RJ11 type), plug one end of a line cord into the "TEL CO LINE" jack for line 1 on the controller and plug the other end into the network interface jack for line 1. Remove the cord labels from the controller box and label the line cord with the green cord labels corresponding to the line jack number. Remove the System Directory Label from the controller box and fill in the telephone number next to the line number. Repeat the procedure for each line:

If your network interface is a two-line jack (RJ14 type), plug in the 267D 2-line adapter into the "TEL CO LINE" jack for line 1 on the controller. Plug one end of a line cord (supplied with the controller) into the "Line 2" jack of the 267D adapter and plug the other end into the "TEL CO LINE" jack for line 2 on the controller. Plug one end of the second D4BU cord into the "PHONE" jack of the 267D adapter and plug the other end into the network interface jack. Label the D4BU cords with the green line cord label numbers as shown in the drawing below and write the appropriate telephone number for each line on the System Directory Label.

Secure the line cords to the wall or baseboard using staples, being careful not to pierce the cords.

*NOTE: If the distance between the controller and the network interface jacks is greater than 7 feet, purchase D4CE extension cords or new D4BU (14' and 25' lengths) line cords.*

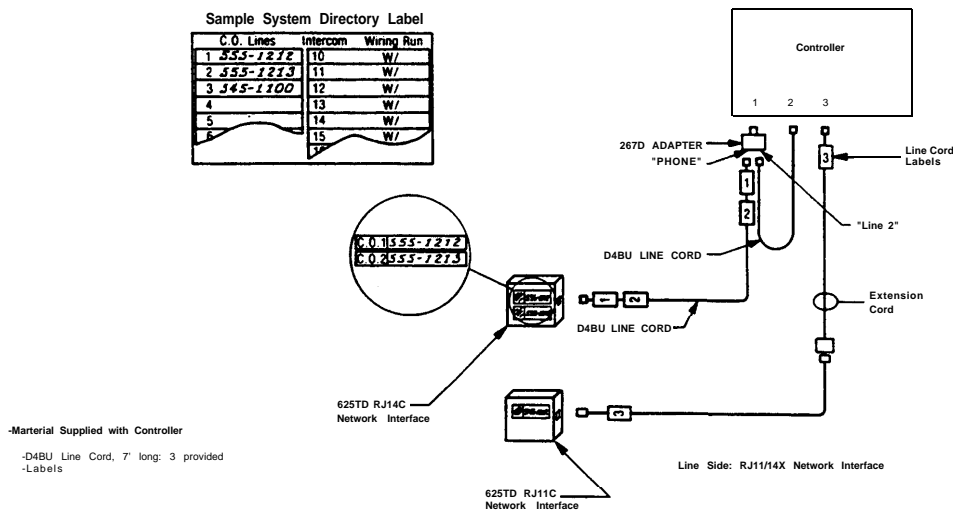



## Step 4 Wiring Runs

You may choose to wire your **SPIRIT** Communications System using 4-pair "business" wiring materials or 2-pair "customer convenience" wiring materials. While the materials are somewhat different, the procedure for labeling the wiring run is the same.

Each "run" from the controller to a telephone set location should be numbered and labeled. Materials for labeling the telephone cords are included with the controller. Do not skip this important step.

If you choose to use the 4-pair "business" wiring materials, the labeling should look like the following:

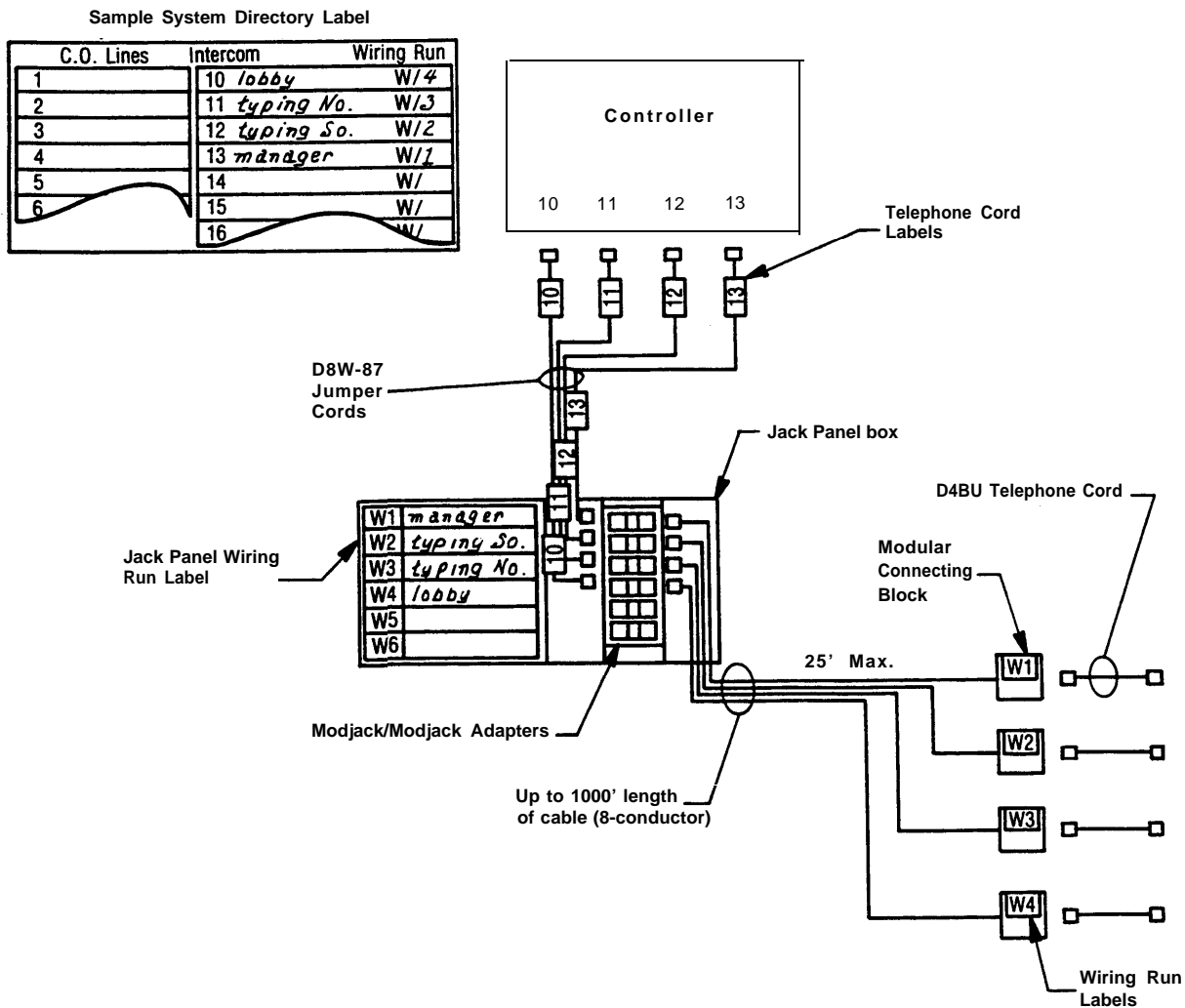

If you choose to wire your system with customer convenience wiring, use the wiring run labels to label *EACH END* of *EVERY* cord, as well as the wire junction boxes.

**Note to installers:** The **SPIRIT** system requires a reversal in the station set wiring. This reversal is in the telephone (tinsel) cord that is packed with the telephone, so all other station set wiring should be straight.

## Step 4A Business (4-pair) Wiring

You may choose to wire your business with 4-pair "business" wiring to be ready for future communications systems.

You will need the following materials:

- screwdriver (flathead)
- scissors
- drill and bits appropriate for your walls
- You will also need the following kits, available from your AT&T representative.

### WIRING INSTALLATION KIT

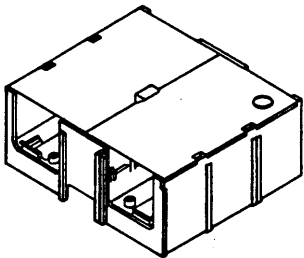

Jack panel box

(Number required depends on number of telephones. You will need one jack panel box per six telephones.)

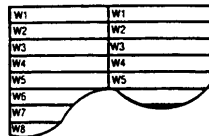

Wiring run labels

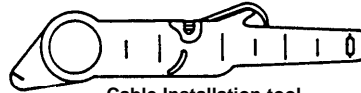

Cable Installation tool



Telephone location stickers

### CABLE EXTENSION KIT

(one per telephone more than 10 feet from the control unit)

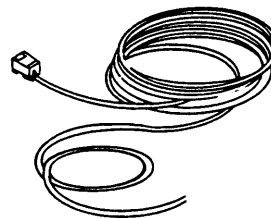

100-or 200-foot length of cable  
(Length depends on distance between control unit and telephone).

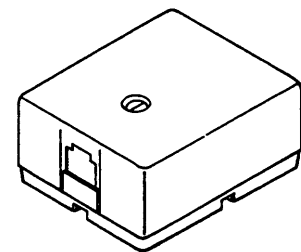

Modular connecting block

### WIRING TERMINATION KIT

(one per telephone)

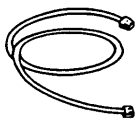

Jumper cord

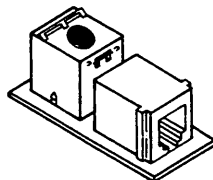

Modjack-to-modjack adapter



Cable clip

## ■ Mount Jack Panel Boxes

Mount the jack panel boxes near the controller, creating a "jack field." You will need one jack panel box for every six telephones in your system. Ideally, the jack field will be two to six inches below the controller if the controller is wall-mounted.

Mounting screws for the jack panel boxes are included in the kit. If you are installing the boxes on a sturdy supporting structure, such as studs or cross members, attach the boxes directly to the walls. If the walls are hollow, mount the jack panel boxes on a board that is about two inches larger all around than the complete jack field (all the boxes mounted together). Then, mount the board on the wall.

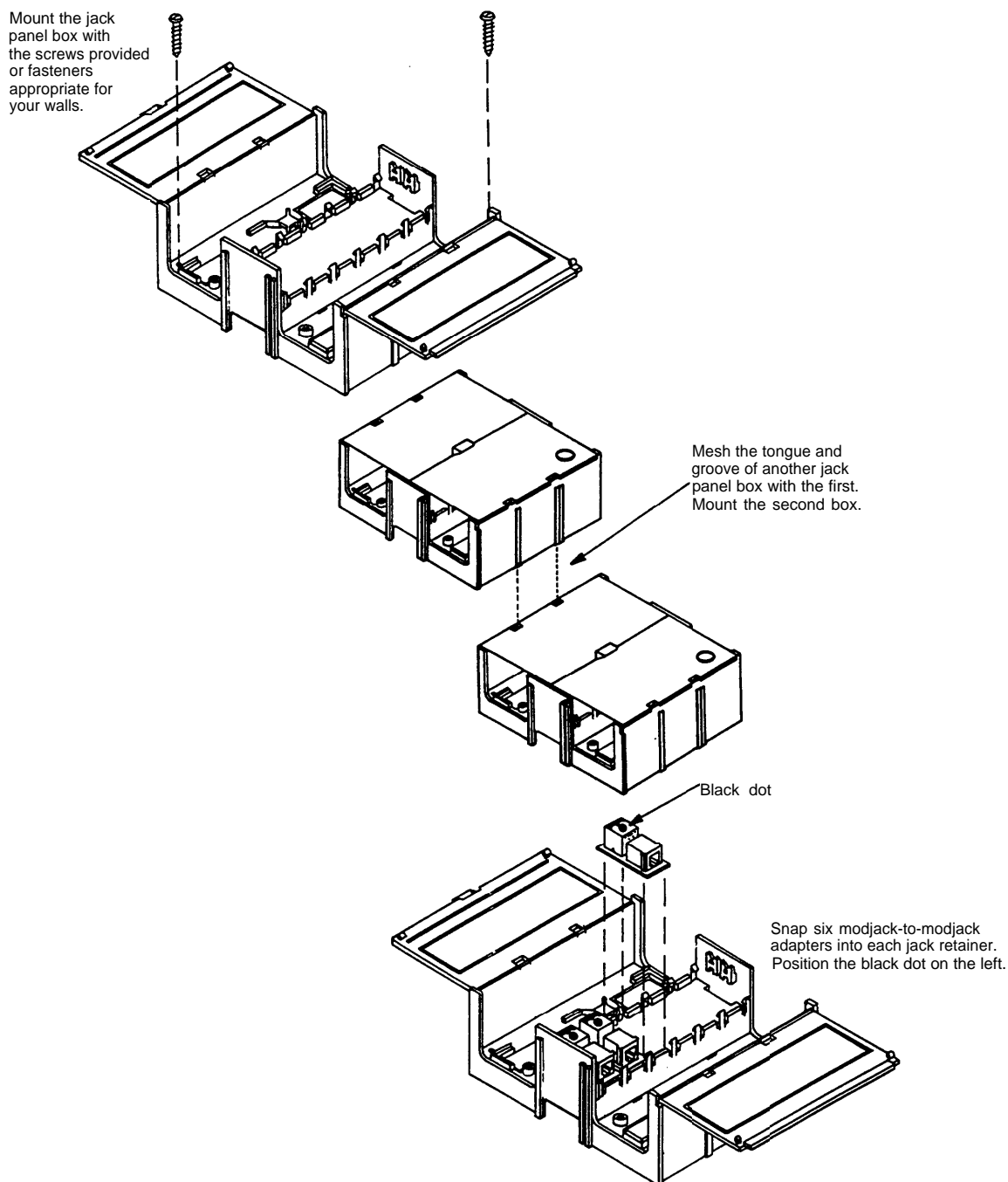

## ■ Run Cable To All Telephone Locations

Select a cable extension kit with the right length of cable (100 or 200 feet) for one cable run. For runs over 200 feet, run a 200-foot cable, terminate it in a modular connecting block, plug in another cable, and repeat, up to a maximum of 1000 feet.

- 1 Select a Cable Extension Kit with the right length of cable (100 or 200 feet) for one cable run. For runs over 200 feet, you will have to run a 200-foot cable, terminate it in a modular connecting block, and plug in another cable. The maximum length of any cable run is 1000 feet.

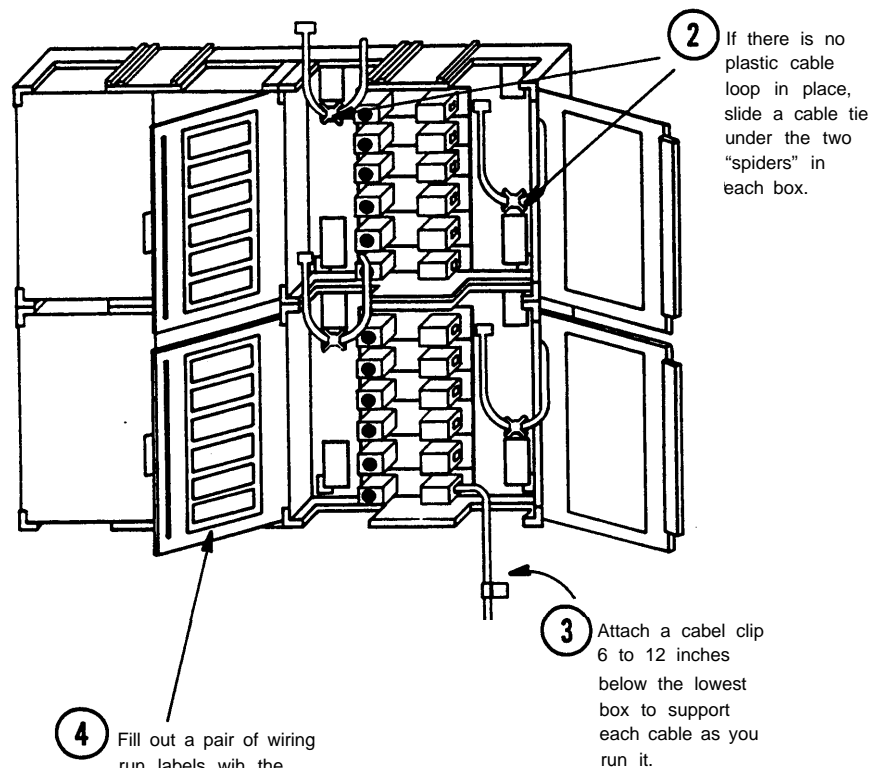

- 4 Fill out a pair of wiring run labels with the telephone location of the first wiring run (for example, W1 shop, W2 sales, W3 RM. 105). Attach one label inside a jack panel door. Save the second label for use on a modular connecting block.

- 5 Plug in the cable connector on the right side. Thread the cable through the clip.

- 6 Run the cable out to the telephone location. Avoid sharp kinks or twists. Use cable clips or staples to dress the cable neatly along wall baseboards, molding, etc. Be careful not to damage the cable with staples.

## ■ Install Modular Connecting Blocks

Install a modular connecting block at each telephone location

- 7** Find the modular connecting block from the Cable Extension Kit and the cable installation tool from the Wiring Installation Kit.

- 8** Choose the location for the connecting block according to the figure. Cut the cable, making sure you allow at least 4 inches extra.

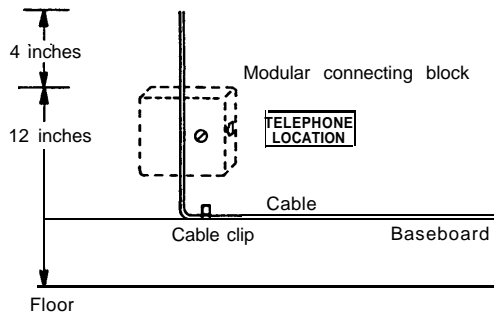

- 9** Fasten the cable to the connecting block as shown in steps A-K, below.

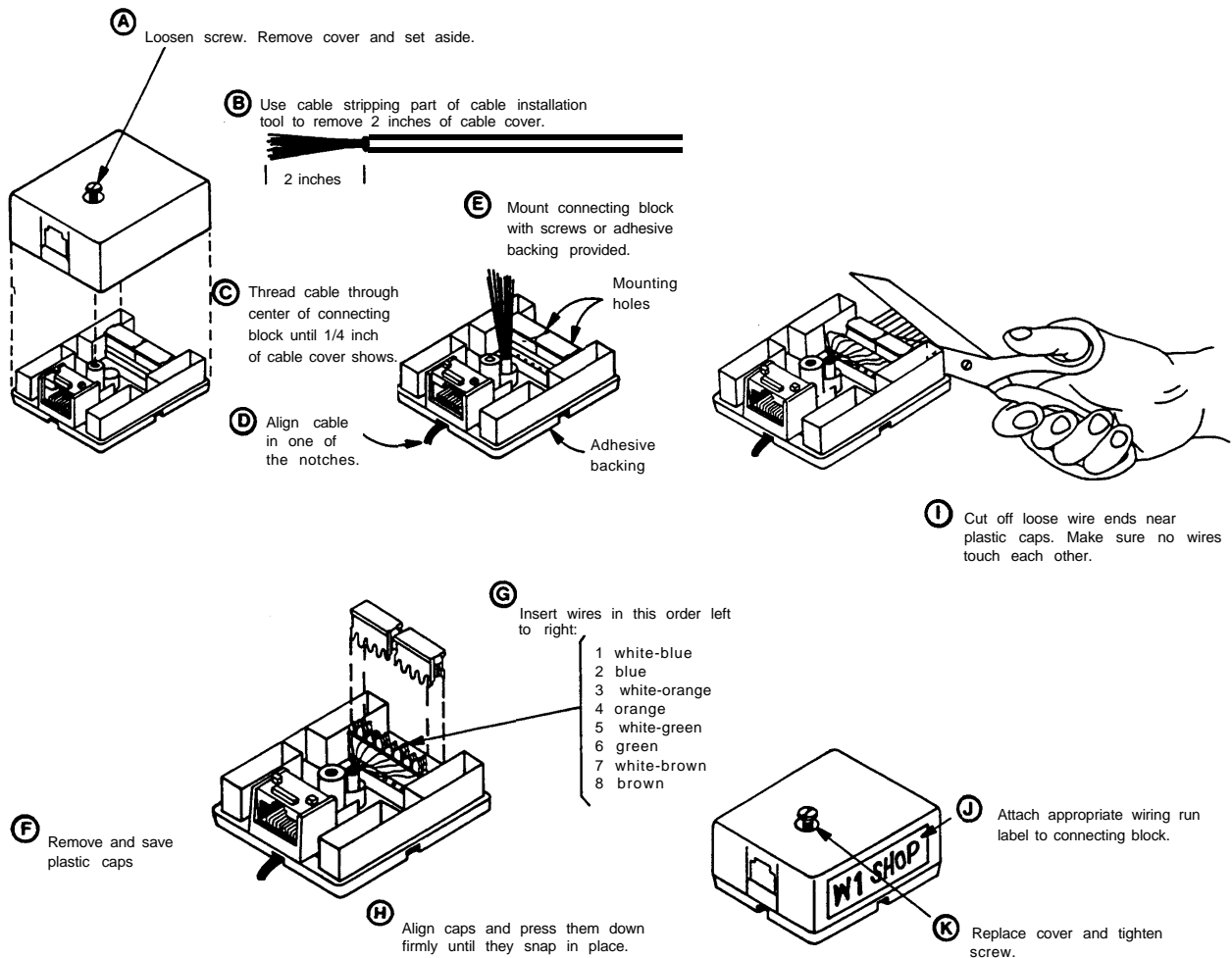

Typical cable installation for one telephone location.

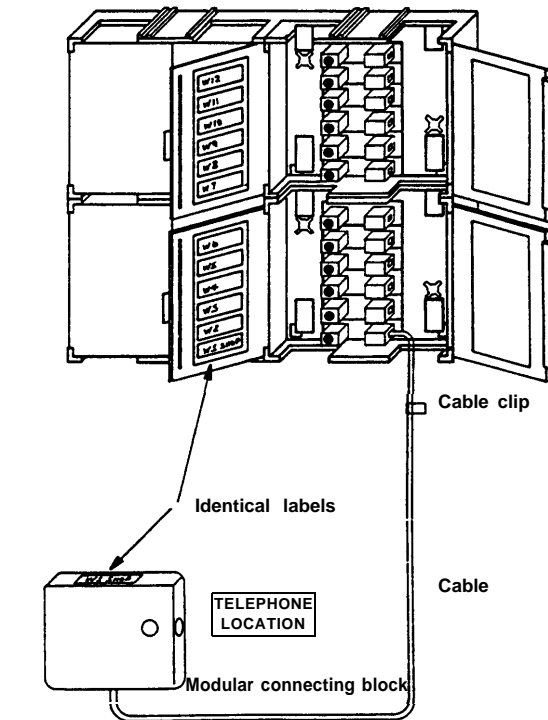

Finish your installation by routing cables to all other telephone locations and installing modular connecting blocks for each one. Be sure to label both ends of each cable run identically.

- 10** Route your other cables and terminate each one in a modular connecting block. Be sure to label both ends of each cable run identically.

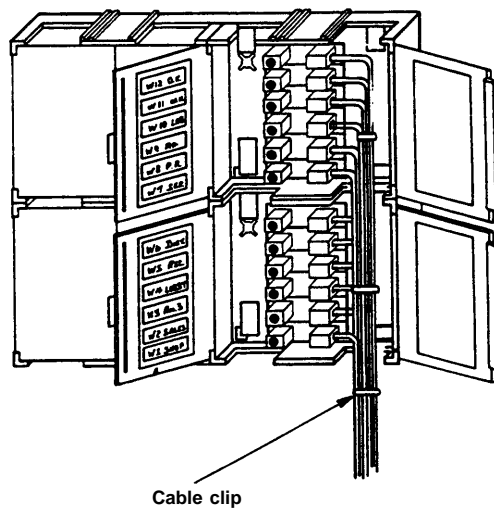

- 11** Dress the cables neatly through the lower openings and secure them with cable clips or ties.

## Step 4B Wiring Run, Using Customer Convenience Wiring

Customer convenience wiring materials are available at your local phone store. Different situations require different materials. For instance, if a telephone location is less than 25 feet from the controller, you may choose to buy a 25' D4BU line cord and plug one end in the modular connecting block of the telephone set and the other end in the corresponding modular connecting block in the controller. Use telephone wire clips to secure the cord to the baseboard and your telephone set is installed.

If distances are greater than 25 feet, but less than the maximum of 1000 feet, you will want to install a wiring run (see page 7). Below is a list of materials needed for installing a wiring run using customer convenience wiring.

- 700 A4 plug—one for every telephone located more than 25 feet from the controller
- wire junction 742B—one for every 50 feet of wire beyond the initial 50 feet
- telephone wire package—one for every 50 feet of wire
- modular connecting block 725A or 625A—one for every desk telephone set
- modular wall connecting block 630B—one for every telephone set to be mounted on the wall
- telephone wire stripper 953A
- telephone wire clips

### ■ Install Plugs

Install a 700A4 plug to the end of the telephone wire that is plugged into the controller. Follow the instructions that are packed with the plug.

### ■ Install Wire Junctions

If the distance between the controller and a telephone set location exceeds 50 feet, install a Wire Junction (742B). Follow the instructions that come with the wire junction. Install telephone wire from each wire junction to each telephone set location. Be sure that you label the telephone cords. This can be repeated up to maximum of 1000 feet.

### ■ Secure Telephone Wire

Secure telephone wire along baseboard with clips. Be careful that you do not damage the wire.

### ■ Install Modular Connecting Blocks

Install a Modular Connecting Block (725A or 625A) within 14 feet of every telephone set that will be desk mounted. Install a Modular Connecting Block for Wall telephones (630B) where every wall-mounted telephone set will be located. Follow the instructions that come with the modular connecting blocks.

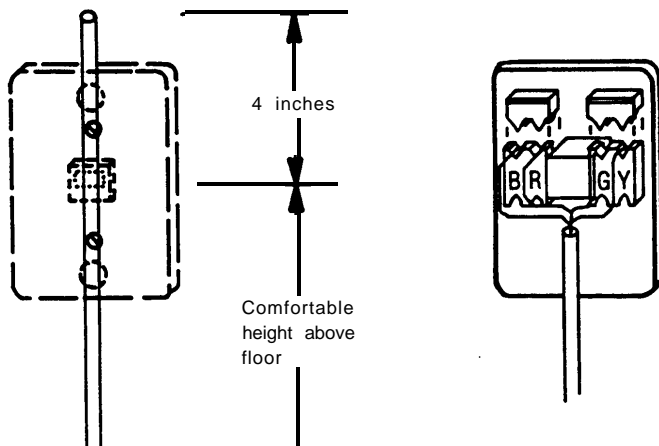

Insert wires in this order:

Customer Convenience Wiring	Business Wiring
Red	blue
Green	blue-white
Yellow	green
Black	green-white

## Typical Installation Using Customer Convenience Wiring

Sample System Directory Label

C.O. Lines	Intercom	Wiring Run
1	10 lobby	W/ 4
2	11 typing No.	W/ 3
3	12 typing So.	W/ 2
4	13 manager	W/ 1
5	14	W/
6	15	W/
	16	W/

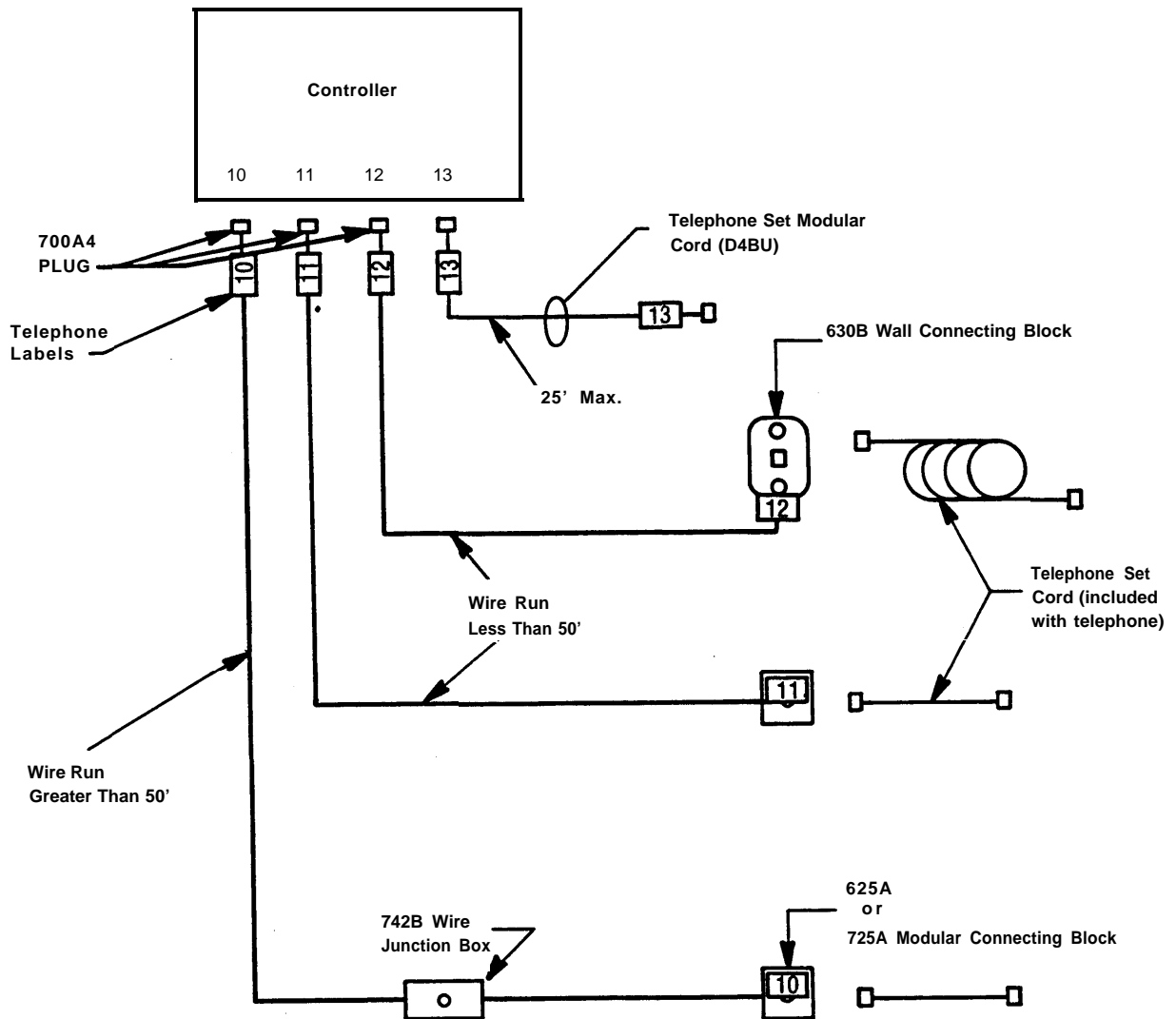

**Note to installers:** The SPIRIT system requires a reversal in the station set wiring. This reversal is in the telephone (tinsel) cord that is packed with the telephone, so all other station set wiring should be straight.



## Step 5 Install Telephone Sets

**SPIRIT** telephone sets are available in 6-Button and 24-Button models. The models are installed the same way. **SPIRIT** telephones are not like regular telephones and will not work if plugged directly into the Network Interface Jacks. Regular telephones will not work if they are plugged into the station jacks on your controller.

### ■ Record Installation Date

Turn the telephone over. Write the installation date on the label located on the bottom of the set above the base.

### ■ Desk Mount

All telephone sets are delivered assembled for desktop use; you need only attach the handset. To install the telephone cord on a desktop set, plug one end of the cord into the jack on the bottom of the telephone. Run the cord through the slot on the bottom of the base so that the cord is retained by the tabs. Plug the other end of the cord into the modular connecting block of that location. Plug the handset cord into the handset.

### ■ Wall Mount

To mount a **SPIRIT** telephone set on the wall, remove the set base by pushing in on the center at the top of the base and pulling the base away from the telephone. Install the base on a 630B Wall Telephone Modular Connecting Block. Plug one end of the telephone cord into the wall connecting block. Wrap surplus cord around the tabs on the base (see picture on left). Plug the other end of the telephone cord into the jack on the back of the telephone set. Insert the top tab of the base into the slot at the top of the set. With one hand, push up on the center of the bottom of the base. Swing the set into position and lock into place.

Slide out the plastic hook (see picture on right) located just above the speaker grill and turn around so the curved section sticks up into the earpiece cradle and holds the receiver in place. Plug the handset cord into the handset.

### ■ Label Intercom Extension Number

Slide out the plastic hook (see picture on right) located just above the speaker grill. Lift the clear plastic window off the hook. Locate the designation labels from the telephone box and tear off the ICM label. Record the intercom extension number of that telephone on the ICM label. Place the label on the plastic hook. Lay the plastic window on the label. Holding the label and plastic window in place, slide the plastic hook back into the telephone.

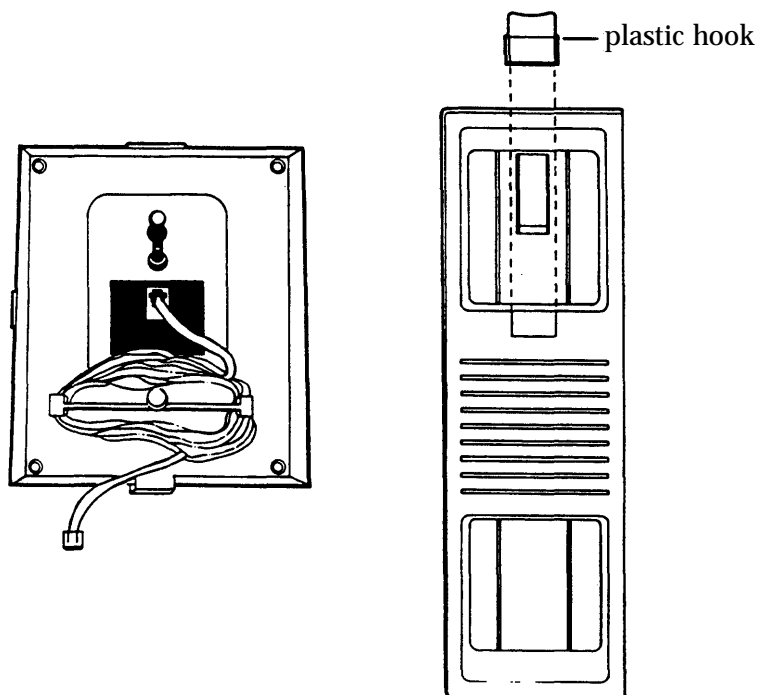

## Step 6 Connect System To Wiring Runs

Connect the controller to the wiring runs. Following the numbers on your wiring run labels, plug one end of a jumper cord into the jack panel box or wire junction (see pages 7 and 14) and the other end of the jumper cord into the appropriate station jack on the controller.

Plug the controller power cord into the AC outlet.

## Testing The System

### ■ Testing the Incoming Telephone Company Lines

Use a standard telephone with a modular cord. Plug the cord into the jacks for the incoming telephone lines. If you can hear a dial tone, the lines are working. If you do not hear a dial tone, contact your local telephone company.

### ■ Testing the Wiring Run

If you cannot get a dial tone on a **SPiRiT** telephone set, check the wiring by carrying the set to the controller and plugging the modular cord into one of the "STATION" jacks on the controller. If you get a dial tone at the controller, but not at the telephone set location, the wiring is at fault.

### ■ Self Test

Your **SPiRiT** Communications System has self-test capabilities that you may use to confirm that the system is installed correctly. The controller test checks that the controller is working properly. You must perform the controller test at telephone 10. If you hear an error tone during the self test, check to make sure that none of the telephones are being used and that all the receivers are in place.

The telephone test, which checks that the telephone is working properly, is performed at each telephone.

### ■ Controller Test

All telephones in the system must be idle.

- At the controller, set the administration switch to ON.
- At telephone 10, press INTERCOM.
- Lift receiver.
- Dial \* 0 9 # \* #

The test takes a few seconds to run. Then the results will be displayed on the indicator lights of telephone 10.

### Results

1. The right INTERCOM light and LINE 1 light should be lit. If either fail to light then there is a defect in the 308 controller.
2. LINE 2 and LINE 3 lights should be lit. If either fails to light then there is a defect in either the 308 controller or the 616 expansion unit if installed. Unplug the power cord, remove the expansion unit, plug in the power cord, and run the test again. If the lights still fail to light then the defect is in the 308 controller. Otherwise, the defect is in the 616 expansion unit.

3. The left INTERCOM light should be lit if there is a 616 expansion unit installed correctly. If there is not an expansion unit installed, and the light does light, then there is a defect in the 308 controller. If a 616 expansion unit is present, check that the connector is properly installed (see the Expansion Unit Installation Instructions for further information) and then run the test again. If the left INTERCOM light still does not light, then there is a defect in either the 308 controller or the 616 expansion unit. To determine which device is at fault, substitute either a working 616 or 308 and run the test again.

4. LINE 4 and LINE 5 lights should be lit. If either fails to light then there may be a problem with the wiring to the sets or a defective set connected to the controller. Disconnect all telephones (except set 10) at the controller "STATION" jacks. Run the test again. If the same results occur, the wiring and sets are working but there is a defect in either the 308 controller or the 616 expansion unit. Unplug the power cord, disconnect the expansion unit, plug in the power cord, and run the test again. If the lights go ON, the defect is in the expansion unit. If the lights still do not light the defect is in the 308 controller.

5. Ignore the rest of the lights on the set.

6. Set the administration switch to OFF.

### ■ Telephone Test

Your telephones may be tested by running a self-test procedure at each telephone set.

To start the test,

Press INTERCOM.

Lift receiver.

Dial # \* #

All of the indicator lights on the set should go ON.

Press any button on the telephone. All of the indicator lights should go OFF.

Press any button on the set. The telephone should ring once. The receiver and the speakerphone microphone should be ON.

Now, check the indicator lights at every button by pressing the button. You should be able to turn ON or OFF an indicator light by pressing the button next to it. If a button does not have an indicator light, the MESSAGE indicator light will turn ON and OFF to indicate that the button is working.

When the SPEAKER indicator light is OFF, the handset receiver (earpiece) and the speakerphone microphone should be ON. Test by rubbing your finger over the microphone (the two small slots next to the # key). You should hear static.

Hangup the telephone to leave self test. (You can always leave self test at any point by hanging up.)

After completing the self test by hanging up the telephone, test the speaker by pressing INTERCOM and then SPEAKER. You should hear a dial tone.

Test the handset transmitter by lifting the receiver and dialing one digit on an outside line. Then set the handset volume to its highest level and blow into the mouthpiece. You should hear the blowing through the handset earpiece.

## Troubleshooting

### *What To Do If You Have Trouble With Your System:*

For **SPIRIT** Communications Systems purchased from AT&T, a customer “hotline” (1-800-628-2888) is available to help you if you have questions about or trouble with your system. If you need assistance from the hotline, please follow these instructions **BEFORE** calling the hotline number. If you have purchased your system from an authorized dealer, these procedures will provide helpful information to have available before you contact your dealer.

Run the controller test (see page 16). At the end of the test, do not hang up the handset until you have observed the HFAI, MESSAGE, MUTE, and SPEAKER lights. Make a note of whether each of those lights is on or off and have the information available when you contact the hotline.

If a telephone is not working properly, exchange it with a working telephone set. You may also check telephone cords, handsets, and handset cords by swapping them with working components.

If you think the wiring may be at fault, take the inoperative telephone to the controller and plug it directly into the corresponding station jack. If it works there, the wiring between the controller and the telephone set is at fault. To check the station jack, plug the inoperative telephone into a station jack that you know is working.

Check the network interface jacks (where the telephone company lines come into your company) by plugging a working standard telephone (**NOT** a **SPIRIT** telephone set) directly into the jack. If the telephone does not work, call your local telephone company.

## Optional Accessories

The controller has jacks for a music on hold source, external alert, and a public address system. The music on hold source requires an RCA-type phono plug. The line level for Music-On-Hold is one volt. A volume control for the music source is located next to the music jack on the controller.

*NOTE: Users of equipment that rebroadcasts copyrighted music or other material may be required to obtain a license from a third party such as ASCAP or BMI.*

## Replacement Parts

*You may order the following **SPIRIT** Communications System equipment.*

<u>Part</u>	<u>Order Number</u>
6-Button Telephone	3130-006A
24-Button Telephone	3130-024A
308 Controller	6030-308
616 Expansion Unit	60301A
Handset	10399X
Handset Cord—6 feet	10239X
Handset Cord—12 feet	2725-OILM
Handset Cord—25 feet	10241X
Telephone Cord—7 feet	10090X
Handset Cord—9 feet	105635437

**Call:** AT&T Sourcebook

**Number:** 1-800-451-2100

**Hours:** 8:00 am to 5:00 pm in all U.S. time zones.

## Free Manuals Download Website

<http://myh66.com>

<http://usermanuals.us>

<http://www.somanuals.com>

<http://www.4manuals.cc>

<http://www.manual-lib.com>

<http://www.404manual.com>

<http://www.luxmanual.com>

<http://aubethermostatmanual.com>

Golf course search by state

<http://golfingnear.com>

Email search by domain

<http://emailbydomain.com>

Auto manuals search

<http://auto.somanuals.com>

TV manuals search

<http://tv.somanuals.com>