

# Five Channel Amplifier

PROCEED

**WARNING:** TO REDUCE THE RISK OF FIRE OR ELECTRIC SHOCK, DO NOT EXPOSE THIS APPLIANCE TO RAIN OR MOISTURE.

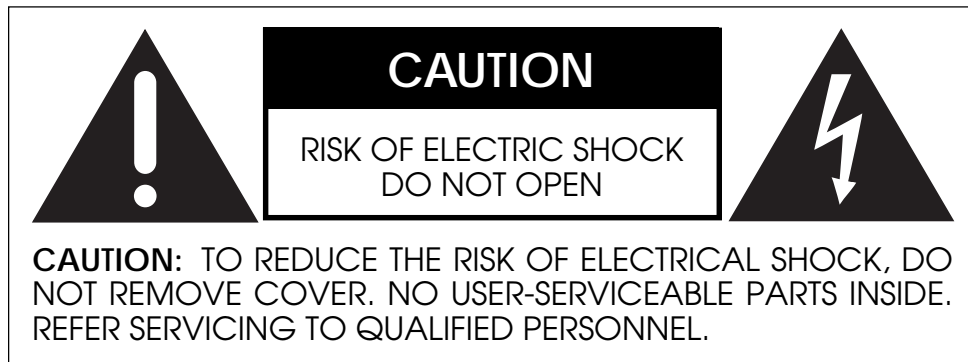

The lightning flash with arrowhead symbol, within an equilateral triangle, is intended to alert the user to the presence of uninsulated “dangerous voltage” within the product’s enclosure that may be of sufficient magnitude to constitute a risk of electric shock to persons.



The exclamation point within an equilateral triangle is intended to alert the user to the presence of important operating and maintenance (servicing) instructions in the literature accompanying the appliance.



Marking by the “CE” symbol (shown left) indicates compliance of this device with the EMC (Electromagnetic Compatibility) and LVD (Low Voltage Directive) standards of the European Community.

The information contained in the manual is subject to change without notice. The most current version of this manual will be posted on our web site at <http://www.madrigal.com>.

# Important Safety Instructions

Please read all instructions and precautions carefully and completely before operating your Proceed power amplifier.

1. **ALWAYS** disconnect your entire system from the AC mains before connecting or disconnecting any cables, or when cleaning any component.
2. This product is equipped with a three-conductor AC mains power cord which includes an earth ground connection. To prevent shock hazard, all three connections must **ALWAYS** be used. If your electrical outlets will not accept this type of plug, an adapter may be purchased. If an adapter is necessary, be sure it is an approved type and is used properly, supplying an earth ground. If you are not sure of the integrity of your home electrical system, contact a licensed electrician for assistance.
3. AC extension cords are not recommended for use with this product. If an extension cord must be used, be sure it is an approved type and has sufficient current-carrying capacity to power this product.
4. **NEVER** use flammable or combustible chemicals for cleaning audio components.
5. **NEVER** operate this product with any covers removed.
6. **NEVER** wet the inside of this product with any liquid.
7. **NEVER** pour or spill liquids directly onto this unit.
8. **NEVER** block air flow through ventilation slots or heatsinks.
9. **NEVER** bypass any fuse.
10. **NEVER** replace any fuse with a value or type other than those specified.
11. **NEVER** attempt to repair this product. If a problem occurs, contact your Proceed® retailer.
12. **NEVER** expose this product to extremely high or low temperatures.
13. **NEVER** operate this product in an explosive atmosphere.
14. **ALWAYS** keep electrical equipment out of the reach of children.
15. **ALWAYS** unplug sensitive electronic equipment during lightning storms.

*From all of us at Madrigal Audio Laboratories, thank you for choosing this Proceed power amplifier.*

*A great deal of effort went into the design and construction of this precision device. Used properly, it will give you many years of enjoyment.*

# Table of Contents

<b>Unpacking and Placement</b> .....	<b>6</b>
Unpacking .....	6
Placement .....	6
Ventilation .....	6
<b>Operating Voltage</b> .....	<b>7</b>
note the serial number .....	7
<i>amplifier bottom-panel label</i> .....	7
<b>A Quick Start</b> .....	<b>8</b>
<b>Special Design Features</b> .....	<b>10</b>
Multiple power supplies .....	10
Low impedance power supply .....	10
Balanced inputs .....	10
Robust output stage .....	10
Extensive protection .....	10
Home THX Audio System certification .....	11
<b>Front Panel</b> .....	<b>12</b>
<b>Rear Panel</b> .....	<b>14</b>
<i>communication cable</i> .....	15
<i>Remote turn-on tip polarity</i> .....	15
<b>Bridged Operation</b> .....	<b>18</b>
Bridging Explained .....	18
Balanced Bridging .....	18
<i>Balanced Bridging Kit</i> .....	19
Single-Ended Bridging .....	20
<i>Single-Ended Bridging Kit</i> .....	21
<b>Biamplication</b> .....	<b>23</b>
<i>Balanced Y-adapter</i> .....	23
<b>Care &amp; Maintenance</b> .....	<b>24</b>
<b>U.S. and Canadian Warranty</b> .....	<b>25</b>
90-Day Limited Warranty .....	25
Five Year Extended Warranty .....	25
<b>Obtaining Service</b> .....	<b>26</b>
<b>Specifications</b> .....	<b>27</b>
<b>Dimensions</b> .....	<b>28</b>
<b>Installation Notes</b> .....	<b>29</b>

# Unpacking and Placement

**Unpacking** Unpack your Proceed® Five Channel Amplifier and **keep all packing materials for future transport**. Shipment of the amplifier without the original packing material is *not* recommended, as it is heavy enough to make improvised packaging impractical. Locate and remove all accessory items from the cartons, and store the cartons for possible future use.

Carefully inspect the product for shipping damage. If you discover any, see your Proceed dealer immediately.

**Placement** Your Proceed amplifier may be placed either near the preamplifier/control center or near the loudspeakers. It may be placed on a shelf or in a cabinet where it is convenient to operate.

*Note that adequate clearance for the AC cord and connecting cables must be left behind your amplifier. We suggest leaving at least three inches of free space behind your amplifier to allow all cables sufficient room to bend without crimping or undue strain.*

**Ventilation** Be sure to allow 2 to 3 inches of clearance above your amplifier to allow heat dissipation through air circulation. The vents on both the bottom and the top of the amplifier must be kept free from any obstruction which would reduce the flow of air through the unit. The best rule of thumb is this: if the top of your amplifier is too hot to touch when “idle,” it needs better ventilation. If so, consider drilling holes in the supporting shelf under the amplifier to promote flow-through ventilation, or use fans to increase air circulation.

Open equipment racks are generally best for power amplifiers, as they allow ample ventilation. If your amplifier must be located inside a cabinet which restricts airflow, consider using some fans to increase ventilation.

Avoid placement on soft surfaces such as carpeting. If you prefer to have the amplifier on the floor near your loudspeakers, be sure to place it on a firm surface. (A piece of tempered glass under the amplifier is aesthetically unobtrusive while providing firm support and allowing the required ventilation.)

Mechanical drawings are included in this manual to facilitate special installations and custom cabinet work (see “Dimensions” at the end of this manual).

## PRECAUTION

---

***For your protection, review “Important Safety Instructions” before you install your amplifier.***

---

# Operating Voltage

The Proceed amplifier is factory-set for 100V, 120V, 220V, or 240V AC mains operation at either 50 or 60 Hz, according to the country for which the unit was manufactured. (*230V in European Union countries, in compliance with CE regulations.*) Make sure that the label on the rear panel of the amplifier indicates the correct AC operating voltage for your location. The operating voltage cannot be changed by the user, and any attempt to do so will void the warranty.

If the voltage indicated does not match the service in your area, see your Proceed dealer.

note the serial number

While you are checking the voltage, it would probably be a good idea to make a record of the serial number for your amplifier. This can be found on the label found on the bottom of the amplifier.

amplifier bottom-panel label



# A Quick Start

We recognize that many people are understandably eager to begin listening to their new components, and that reading the manual is often done (if at all) at a later time—perhaps while listening to music through the new product itself. We strongly recommend that you read this manual thoroughly.

Fortunately, we can help you get some music up and running on your system quickly, so that you may begin enjoying your new amplifier while reading more about it. The goal here is simply to make some music as quickly as possible.

The following procedure assumes that the rest of your system is already connected (e.g., source components to preamplifier).

## **1 TURN DOWN THE VOLUME ON YOUR PREAMPLIFIER**

Turning the volume on the preamp all the way down minimizes the opportunity for unpleasant surprises when first powering up your new amplifier. It does not need to be turned off—merely turned down.

## **2 SELECT “XLR” OR “RCA” WITH THE “INPUT SELECT” SWITCHES**

Each channel of the Proceed Five Channel Amplifier has both balanced (XLR) and single-ended (RCA) inputs, with a small switch between the two connectors to select between them. Using these switches, select the appropriate input for each channel, given your interconnecting cables and preamplifier/controller’s capabilities.

## **3 CONNECT YOUR PREAMP TO THE AMPLIFIER**

Having selected the appropriate inputs in Step 2, now connect the outputs of your preamplifier to the corresponding inputs on the power amplifier.

## **4 CONNECT YOUR SPEAKERS TO THE AMPLIFIER**

Connect speaker wire from the amplifier to your loudspeakers. Be sure to maintain consistency in polarity, e.g., the red post on the amplifier to the red connector on the speaker, and likewise black to black. (Getting the wires mixed up won’t damage anything, but the sound will be lacking in bass and the imaging will be quite poor and unstable.)

## **5 CONNECT THE AC CORD TO THE AMPLIFIER AND TO YOUR AC OUTLET**

The AC receptacle for the power cord is located on the right side of the rear panel, as seen from the front.

## **6 TURN ON THE AMPLIFIER BY PRESSING POWER, THEN STANDBY**

Press the latching **power** button on the front panel of the amplifier (small, near the bottom) to connect the amplifier to the AC mains. The amplifier will initially power up in standby mode. After five seconds (to let the power supply charge up), pressing the large silver **standby** button will bring the amplifier out of standby into its normal, fully operational mode.



**7 SLOWLY RAISE THE VOLUME ON YOUR PREAMPLIFIER**

Congratulations! You should now be able to enjoy your favorite music while reading the rest of this manual. *(Please, do read the rest of this manual. It contains much valuable information about your new amplifier which we could not possibly fit onto these two pages.)*

# Special Design Features

Congratulations on your purchase of a Proceed amplifier! While your new amplifier is straightforward in its use, it includes several design features which are responsible for its outstanding performance. A few of these are given below.

## **Multiple power supplies**

Unlike other multichannel amplifiers, your new amplifier maintains outstanding isolation and independence among its five channels. Three large toroidal transformers are used, with complete left/center/right channel separation maintained throughout. Separate secondary windings for front vs. rear channels on the Left and Right transformers feed separate rectifiers and separate banks of filter caps. In short, after the transformer, each channel has its own, dedicated power supply.

This approach reduces crosstalk between audio channels for superior imaging and reproduction of acoustic space. Any demands placed on one channel have virtually no effect on the performance of the other channel(s).

## **Low impedance power supply**

A critical factor in the ultimate performance of an amplifier is its "power supply impedance," which can be loosely thought of as the freedom with which the audio circuitry has access to the power it needs, when it needs it. The design of your Proceed amplifier has addressed this important characteristic in a comprehensive fashion. For example, the power supply capacitors (which act as "reservoirs" of power for the amplifier circuitry) are mounted directly to the printed circuit board rather than using point to point wiring. The layout of the circuitry uses short, thick traces for high current paths. Internal current capability is further enhanced with high purity copper bus bars. This attention to detail yields an optimal environment in which the amplifier may operate to its maximum potential.

## **Balanced inputs**

Each channel of your amplifier is individually configurable to receive either balanced or single-ended inputs. This approach allows you to take full advantage of the greater immunity from noise, RFI, and EMI which balanced transmission of audio signals offers on any preamp-to-amplifier connection where it is supported. At the same time, any or all channels of the amplifier may be configured for single-ended inputs to maintain compatibility with the majority of preamplifiers available today. The gain structure of the amplifier adjusts automatically when you select different inputs to facilitate this "mix and match" approach.

## **Robust output stage**

Each channel of your Proceed amplifier uses ten 150 watt power transistors. These transistors are all individually tested and sorted, and are used in matched sets to ensure that no one transistor bears a disproportionate part of the overall load. The combination of an "overbuilt" design specification and extraordinary attention to detail in manufacturing improves performance, reliability, and longevity.

## **Extensive protection**

Your Proceed amplifier will shut itself down if it senses either the presence of either DC (direct current) or a short circuit at the output, or any unsafe operating temperature. In any case, a power relay will cause the amplifier to be disconnected from the AC mains. In addition, the AC input to each transformer is fused to protect against any possibility of component-level failure that could draw dangerous amounts of power. Finally, inrush limiting prevents premature aging of

**Home THX Audio  
System certification**

power supply components during power-up, and switches off-line once the power supply has been charged.

Lucasfilm, Ltd.<sup>®</sup> has established minimum standards for the performance of various components which may be used in their Home THX<sup>®</sup> Audio System. With respect to power amplifiers, the standards address such things as:

- a low electrical noise floor to allow low-level information to be fully appreciated;
- the absence of any mechanical noise (fan noise, transformer winding buzzes), for the same reason;
- adequate power to meet the demands of modern films (which can be *quite* dynamic);
- flat frequency response for accurate reproduction of timbre;
- stability into relatively extreme loudspeaker loads, to ensure that the amplifier will perform well with a wide range of loudspeakers.

As you can see from this list, there is nothing about the Home THX amplifier specification that is particularly radical. It simply ensures a certain minimum standard of performance. In particular, there is nothing in the nature of the amplifier specification which prevents anyone from going above and beyond the minimum performance levels required by THX certification.

Your Proceed amplifier is certified for use in Home THX audio systems. Madrigal engineers have created this powerful, versatile and extraordinarily *musical* power amplifier, using the technology and design methodology for which they have become so well known. Equally suited to the rigors of film soundtracks and the fineness of high end music reproduction, the Proceed Five Channel Amplifier serves both needs quite well. In today's growing market for multipurpose systems, it represents an extraordinary value.

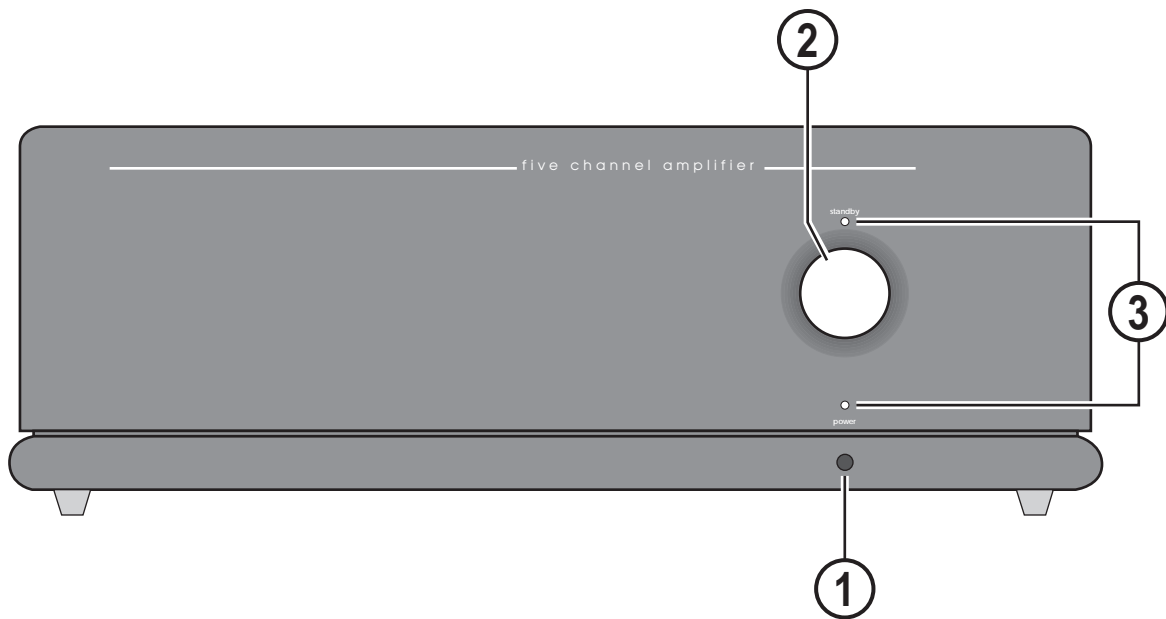

## Front Panel

### 1 POWER BUTTON

Pressing this latching **power** button connects the amplifier to the AC mains, charges the power supply (which takes about five seconds), and places it in standby. Having a true standby function keeps the sensitive voltage gain stages warmed up and sounding their best at all times. Power consumption when in standby is less than 150 watts.

Note that if the amplifier has been disconnected from the AC mains power by depressing the front panel **power** button or by unplugging it from the AC outlet, it cannot respond to a remote turn-on command from a control unit. If you wish the amplifier to turn on and off via the Proceed communications bus (or by a DC trigger), the amplifier needs to be in standby, with this **power** button engaged.

### 2 STANDBY BUTTON

Assuming that the power is on and the unit is in standby (see 1, above), pressing the **standby** button engages the output stage of the amplifier, taking it from **standby** to fully **on**. Pressing the **standby** button again will toggle the amplifier back to standby. Power consumption when fully on and at idle is less than 250 watts.

At your option, you may also toggle the amplifier between **standby** mode and fully **on** by connecting a suitable 5-12V DC trigger such as can be provided by the Proceed PDSD or AVP to its **remote trigger input**.

Note that pressing the **standby** button has no effect until after the power supply is fully charged.

Note also that if the amplifier has been disconnected from the AC mains power by depressing the front panel **power** button, it cannot respond to a remote turn-on command from a control unit.

### 3 INDICATOR LIGHTS

The **power indicator light** (above the small **power** button, *below* the large **standby** button) is normally either on or off, indicating whether AC power is being supplied to the amplifier. It will *blink* on and off if the amplifier's protection circuitry has been engaged (shutting the amp off to protect itself and/or your loudspeakers). In the unlikely event that you see the power indicator blinking, disconnect the amplifier from AC power and call your dealer for assistance in solving the problem.

The **standby indicator light** (above the large **standby** button) glows either amber or red, depending on the operational status of your amplifier. Amber indicates that the amplifier is **on** and ready to be used. When the indicator light is glowing red, the unit is in **standby**. If the standby indicator light is completely off, the amplifier is not receiving power. Check your AC connections and the rear-panel AC fuse.

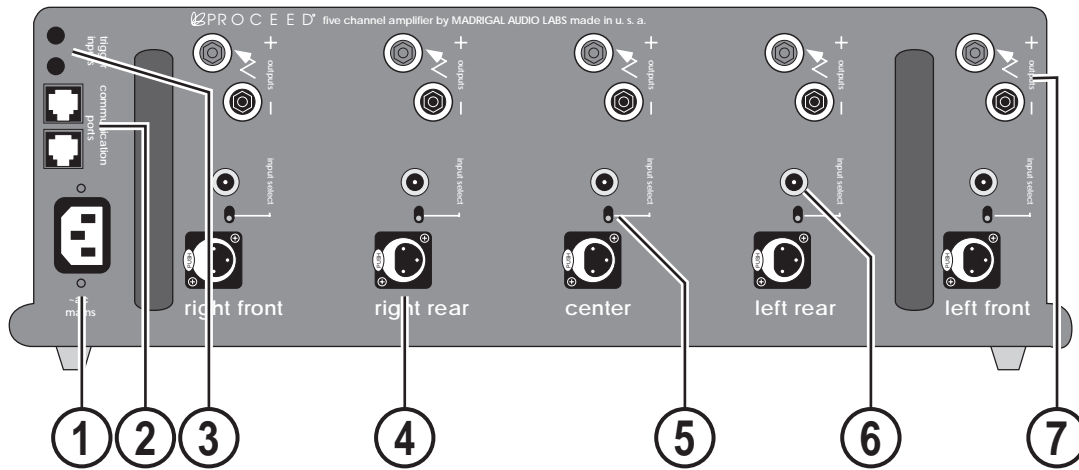

## Rear Panel



### Caution!

*Turn the volume on your controller/preamplifier all the way down before attempting to connect anything to your Proceed Five Channel Amplifier.*

### 1 AC MAINS RECEPTACLE

Connect the AC power cord (included in the accessory pack) to the IEC-standard AC receptacle on the rear panel of the amplifier, then to the AC mains outlet.



### Warning!

*Your Proceed amplifier has been safety-tested and is designed for operation with a three-conductor power cord. Do not defeat the "third pin" or earth ground of the AC power cord.*

### 2 COMMUNICATION PORTS

These RJ-45 communications ports provide for sophisticated inter-component communications within the context of a Proceed system, allowing the multichannel controller to toggle the amplifier between **operate** and **standby** as needed, without forcing the user to turn the amplifier on separately. Since this communication link provides two-way communication, it is more reliable and preferred over simpler DC trigger hookups (although we support DC triggers as well, since their use is so widespread).

These two RJ-45 communications ports also support the PHAST™ inter-component communications protocols, greatly simplifying the design and installation of sophisticated home automation systems. They provide two-way communication with the home automation controller as to the amplifier's current status, ensuring reliable execution of sophisticated turn-on and shutdown macros.

To use these ports, simply daisy chain the various Proceed products together. The modular cable needed for the connection may be purchased from your Proceed dealer. It may also be easily and inexpensively made to length using two modular connectors and the appropriate length (up to 100 feet/30 meters) of flat, eight conductor cable.

Modular cables and connectors are used throughout the world for both telecommunications and computers, and are widely available at low cost. The connectors are crimped on to the ends of the cable such that pin 1 at one end is connected to pin 1 at the other end. Such a "straight-through" connection is (counter-intuitively) made by introducing a 180° twist in the cable between the two ends, as shown below.

communication cable

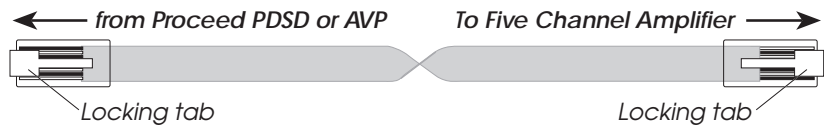

### 3 REMOTE TURN-ON ("TRIGGER") JACKS

Two 1/8" "mini" jacks above the AC mains receptacle on the rear panel allows remote-controlled turn-on (that is, toggling between operate and standby) of the Proceed amplifier. These remote "triggers" will be operated by the presence of 5–12 volts DC, with tip polarity as shown below:

Remote turn-on  
tip polarity



The presence of a suitable DC voltage will cause the amplifier to be fully on; the absence of such a voltage will cause it to enter standby. Your Proceed dealer can help you take advantage of these design features to maximize your system's versatility.

Since these trigger inputs are wired in parallel, you can go into one and out of the other to facilitate a "daisy-chain" of turn-on triggers (should you have additional products that need to be controlled in this manner).

**Special note:** if this method of control is used for the amplifier(s), the last mini-jack in the chain must be terminated with a dummy 1/8" plug [that is, an empty plug must be inserted into the final 1/8" (3.5 mm) jack]. Even if only a single amplifier is controlled in this fashion, the "extra" mini-jack must be terminated.

If you are not using these turn-on inputs, you may leave them both empty of any plugs.

#### 4 BALANCED AUDIO INPUTS

Accepts signals from preamplifiers with balanced outputs via high quality XLR connectors.

The pin assignments of these XLR-type female input connectors are:



- Pin 1: Signal ground
- Pin 2: Signal + (non-inverting)
- Pin 3: Signal – (inverting)
- Connector ground lug: chassis ground

These pin assignments are consistent with the standards adopted by the Audio Engineering Society. Refer to the operating manual of your balanced-output preamplifier to verify that the pin assignments of its output connectors correspond to your Proceed amplifier. If not, wire the cables so that the appropriate output pin connects to the equivalent input pin.

If you are planning to use balanced connections between your preamplifier and any particular channel of the amplifier, select the balanced input by sliding the **input select switch** (see Item 5, below) toward the XLR input. Then connect the balanced outputs of your preamplifier to the corresponding balanced inputs on the amplifier using high quality cables such as CZ Gel-1.

#### 5 INPUT SELECT SWITCH

This small switch is found between the balanced XLR input and the single-ended RCA input on each channel of the amplifier. Use it to select which of the two inputs you plan to use.

The input select switch disables the unselected input in order to avoid any pickup of stray noise from what would otherwise be an open input. It also causes the effective gain of that channel to be adjusted (either 23 dB balanced or 29 dB single-ended, to compensate for the 6 dB difference in signal level in these two connection standards). Should you use your amplifier in a home theater system, this adjustment allows you to use any combination of balanced and single-ended connections without having to worry about going outside the adjustment range of your surround decoder's output calibration circuitry.

#### 6 SINGLE-ENDED INPUTS

Accepts signals from preamp/controllers with single-ended outputs via high quality RCA connectors.

If you are planning to use single-ended connections between your preamplifier and any particular channel of the amplifier, select the single-ended input by sliding the **input select switch** (see Item 5) toward the RCA input. Then connect the single-ended outputs of your preamplifier to the corresponding single-ended inputs on the amplifier, using high quality cable such as CZ Gel-2.



## 7 SPEAKER OUTPUTS & BINDING POSTS

The Proceed amplifier is equipped with gold-plated, high-current binding posts for output termination to a loudspeaker system. To take full advantage of the AMP's sonic quality, we recommend using high-quality speaker cable; see your Proceed dealer.



**Caution!**

---

**NEVER connect the amplifier output terminals to any device other than a loudspeaker.**  
**NEVER short-circuit the amplifier's output terminals.**

---

There are two recommended methods for connecting speaker cables to the amplifier. A high-quality spade lug or hook lug, soldered to the cable (or crimped with extremely high pressure), is best.

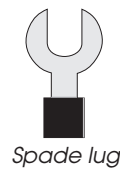

For each channel in turn, connect the left-channel – (negative or black) output post of the amplifier to the – (negative or black) input terminal of the appropriate loudspeaker.

Then connect the + (positive or red) output post of the amplifier to the + (positive or red) input terminal of the appropriate loudspeaker.

Repeat this procedure for all remaining channels.

# Bridged Operation

Your Proceed amplifier has been designed to be extremely versatile. Should your needs change or grow over time, you may wish to add additional power by one of two means: Bridging, or Biamping. We will discuss bridged operation first.

## Bridging Explained

Bridging refers to the act of reconfiguring the circuitry in two channels of your amplifier to act as though it were a single, much larger amplifier. (Of course, this reduces the number of available channels; you may need more amplifiers to make up the difference.)

Bridging is accomplished by sending a normal signal to one channel and an *inverted* signal to the other. In this configuration, one channel will always be “pushing” when the other is “pulling.” By connecting the loudspeaker leads across the left and right red output terminals, the amplifier can now deliver twice the normal voltage to the loudspeaker. Working together this way, the two amplifier channels can deliver about *four times* the power to a speaker that a single channel could deliver on its own.

Bridged operation is particularly beneficial with low sensitivity, high-impedance loudspeakers ( $8\Omega$  or higher) that have a greater need for voltage than for current. It is not recommended for low-impedance loudspeakers, as the speaker's impedance is “split” by the two halves of the amplifier. Thus the bridged amplifier “sees” a  $2\Omega$  load when connected to a  $4\Omega$  loudspeaker. Delivery of high power into such a low impedance creates a great deal of heat that needs to be dissipated. (Of course, your amplifier is protected against overheating, but having an amplifier shut itself down even temporarily can put a damper on the evening's entertainment.)

## Balanced Bridging

If your preamplifier has balanced outputs, you should use them. For this discussion, we will assume that you are using a Madrigal Balanced Bridging Kit for each channel to be bridged. (Alternatively, you may have custom cables built using your preferred wire and connectors, being careful to follow the wiring diagram below.)

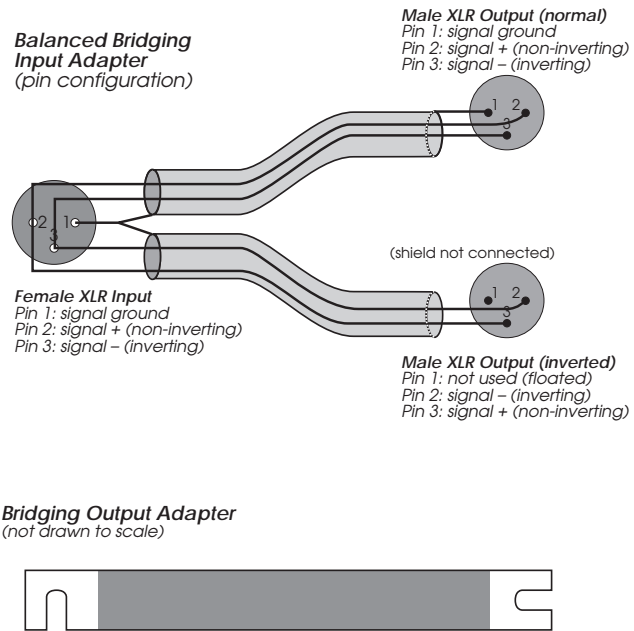

The “normal” leg of the Madrigal Balanced Bridging Input Adapter will be marked with a red stripe to indicate positive polarity, and the inverted leg will be marked with a black stripe to indicate inverted polarity (corresponding to the red and black terminals of your loudspeaker).

The Balanced Bridging Output Adapter is simply a heavy-gauge copper bar (silver- and gold-plated) used to strap two of the output ground terminals together. This establishes a common reference for the amplifier and completes the circuit that includes the loudspeakers.

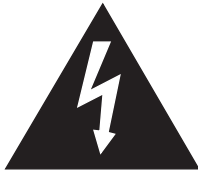

**Important!**

***Do not attempt to operate your amplifier in a bridged mode without first strapping the black output terminals together. Failure to establish a common ground reference between the two channels can damage your amplifier by forcing significant currents to flow where they do not belong!***

To bridge your amplifier using a balanced input signal, follow these steps:

- 1 DISCONNECT YOUR AMPLIFIER FROM EVERYTHING**  
Start with your amplifier totally disconnected from inputs, outputs, and AC power. It is always best to power down an amplifier before changing connections; here you are also changing its basic configuration, making this step essential.
- 2 CONNECT THE BALANCED BRIDGING INPUT ADAPTER TO THE INPUTS**  
Connect the two male XLRs to two adjacent inputs on your amplifier, noting which XLR is marked red and which is black. The channel with the red, normal input will later be connected to the red, positive terminal of your loudspeaker. Don't forget to choose the balanced input on each channel using the switch located between the XLR and the RCA connectors.

**3 CONNECT THE BALANCED BRIDGING OUTPUT ADAPTER TO THE TWO BLACK OUTPUT TERMINALS**

Connect one end of the Balanced Bridging Output Adapter to a black output terminal on one of the two channels to be bridged together, and then connect the other end of the Output Adapter to a black output terminal on the other channel. Make sure these connections are snug and secure. (If you need to use two channels of a different spacing—for example, two center channel in different amplifiers—you can use a heavy gauge speaker wire for this purpose.)

**4 CONNECT YOUR LOUDSPEAKER WIRE ACROSS TWO RED OUTPUT TERMINALS, ONE TO EACH OF THE TWO CHANNELS BEING BRIDGED**

Please read the following carefully:

Connect the positive/+ /red binding post of your loudspeaker to the red output terminal associated with the red (normal) side of the Input Adapter.

Connect the negative/- /black binding post of your loudspeaker to the *red* output terminal on the other side of the amplifier, the one associated with the black (inverted) side of the Input Adapter.

Following this connection convention preserves the polarity of the signal sent to the loudspeaker. In practice, the most important thing is to be consistent throughout the system, as inconsistency will result in out-of-phase loudspeakers. In turn, this results in unstable imaging and poor bass reproduction. (The effect is not dangerous, but neither is it desirable.)

**5 CONNECT ONE OUTPUT CHANNEL OF YOUR PREAMPLIFIER TO THE INPUT OF YOUR BRIDGED AMPLIFIER**

The female XLR at the junction of the Balanced Bridging Input Adapter is now the *single* input to this *bridged* pair of amplifier channels.

**6 POWER UP YOUR AMPLIFIER**

Plug the amplifier back into the AC mains; press the **power** button to turn on the amplifier.

**7 REPEAT THIS PROCESS WITH YOUR OTHER AMPLIFIER(S)**

**Single-Ended Bridging**

If your preamplifier has only single-ended (RCA) outputs, a few details of bridged operation will differ from the discussion above, all pertaining to the connection of the preamp to the bridged amplifiers. For this discussion, we will assume that you are using a Madrigal Single-Ended Bridging Kit for each channel to be bridged. (Alternatively, you may have custom cables built using your preferred wire and connectors, being careful to follow the wiring diagram below.)

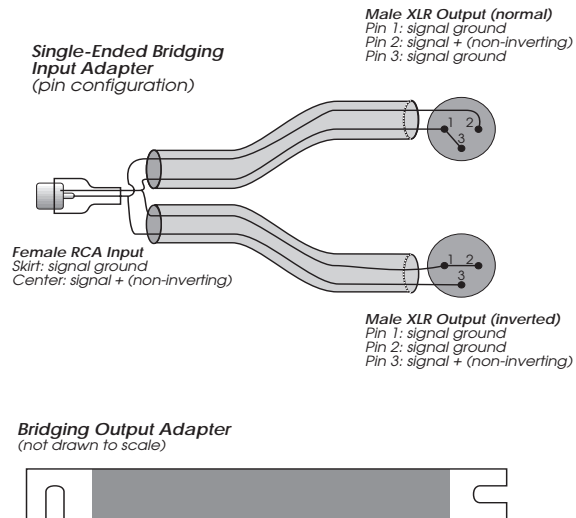

The “normal” leg of the Madrigal Single-Ended Bridging Input Adapter will be marked with a red stripe to indicate positive polarity, and the inverted leg will be marked with a black stripe to indicate inverted polarity (corresponding to the red and black terminals of your loudspeaker).

The Balanced Bridging Output Adapter is simply a heavy-gauge copper bar (silver- and gold-plated) used to strap two of the output ground terminals together. This establishes a common reference for the amplifier and completes the circuit that includes the loudspeakers.



**Important!**

***Do not attempt to operate your amplifier in a bridged mode without first strapping the black output terminals together. Failure to establish a common ground reference between the two channels can damage your amplifier by forcing significant currents to flow where they do not belong!***

To bridge your Proceed amplifier using a single-ended (RCA) input signal, follow these steps:

- 1 DISCONNECT YOUR AMPLIFIER FROM EVERYTHING**  
Start with your amplifier totally disconnected from inputs, outputs, and AC power. It is always best to power down an amplifier before changing connections; here you are changing its basic configuration, making it essential.
- 2 CONNECT THE SINGLE-ENDED BRIDGING INPUT ADAPTER TO THE AMP'S INPUTS**  
Connect the two male XLRs to two inputs of your amplifier, noting which XLR is marked red and which is black. The channel with the red, normal input will later be connected to the red, positive terminal of your loudspeaker.

**3 CONNECT THE SINGLE-ENDED BRIDGING OUTPUT ADAPTER TO TWO SIDE-BY-SIDE BLACK OUTPUT TERMINALS**

Connect one end of the Balanced Bridging Output Adapter to a black output terminal on one side of the amplifier, and then connect the other end to a black output terminal on the other side of the amplifier. (The two connections should be side-by-side rather than one above the other.) Make sure these connections are snug and secure.

**4 CONNECT YOUR LOUDSPEAKER WIRE ACROSS TWO SIDE-BY-SIDE, RED OUTPUT TERMINALS**

Please read the following carefully:

Connect the positive/+ /red binding post of your loudspeaker to the red output terminal associated with the red (normal) side of the Input Adapter.

Connect the negative/- /black binding post of your loudspeaker to the red output terminal on the other side of the amplifier, the one associated with the black (inverted) side of the Input Adapter.

Following this connection convention preserves the polarity of the signal sent to the loudspeaker. In practice, the most important thing is to be consistent throughout the system, as inconsistency will result in out-of-phase loudspeakers. In turn, this results in unstable imaging and poor bass reproduction. (The effect is not dangerous, but neither is it subtle.)

**5 CONNECT ONE OUTPUT CHANNEL OF YOUR PREAMPLIFIER TO THE INPUT OF YOUR BRIDGED AMPLIFIER**

The female RCA at the junction of the Single-Ended Bridging Input Adapter is now the *single* input to this *bridged* amplifier.

**6 REPEAT AS NEEDED FOR OTHER CHANNELS**

**7 POWER UP YOUR AMPLIFIER**

Plug the amplifier back into the AC mains; engage the **power** button, followed a few seconds later by pressing **standby** to turn on the amplifier.

# Biamplication

In contrast to bridged operation (wherein two amplifier channels are “fooled” into behaving as a single, larger channel), biamplication makes use of two channels to drive *different portions* of a single loudspeaker. As with bridging, it offers a modular way of increasing the overall performance of your system (if your loudspeakers support biamplication).

Since each channel of the amplifier is delivering current into its load only over a limited range of frequencies (typically bass *vs.* mids and treble), several forms of distortion may be reduced as compared to each channel handling the full range of musical information. For this reason, many loudspeaker companies are designing their products to include multiple speaker inputs (since using multiple amplifiers improves the performance of their products as well). Another common use of biamplication involves adding a subwoofer (along with an appropriate electronic crossover) to supplement and/or improve the deep bass performance of your system.

Always refer to the specific directions provided by your loudspeaker manufacturer prior to setting up a biamplified speaker system. Any instructions contained herein cannot be substituted for those that are specific to the loudspeaker in question. In general, however, biamping is done in one of two ways: *active* biamplication, or *passive* biamplication.

Active biamping refers to the presence of an “active” electronic crossover that divides the music into two (or sometimes more) bands of frequencies. These are then forwarded to separate power amplifiers, and sent on directly to the appropriate drivers in the speakers. The most common application of this approach is the use of a subwoofer crossover to separate the deep bass (below, say, 80 Hz) from the rest of the program material. It is then amplified separately and sent to a dedicated subwoofer designed to handle those extremely low frequencies.

Apart from adding a subwoofer, the next most common form of biamping (called *passive* biamplication) involves merely using a conventional “Y-adaptor” (either balanced or single-ended) to provide a full range signal to two channels.

Balanced Y-adapter

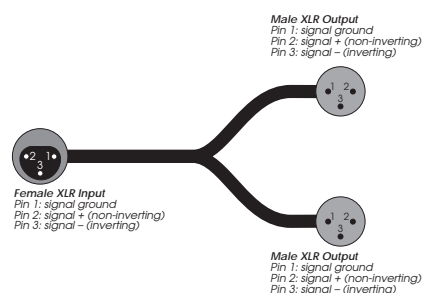

The outputs of these two channels are then connected to two sets of binding posts on each loudspeaker. (See below.) The loudspeaker’s internal crossover continues to divide the frequencies appropriately among the various drivers.

To facilitate biamping, all Proceed power amplifiers have the same voltage gain and input sensitivity. Because of this fact, you should not have to concern yourself with adjusting the relative volumes of the bass and treble sections of your loudspeakers—if they sounded good with a single amplifier, they should sound better when biampified.

# Care & Maintenance

To remove dust from the cabinet of your amplifier, use a feather duster or a lint-free soft cloth. To remove dirt and fingerprints, we recommend isopropyl alcohol and a soft cloth. Dampen the cloth with alcohol first and then lightly clean the surface of the amplifier with the cloth. Do not use excessive amounts of alcohol that might drip off the cloth and into the amplifier.



**Caution!**

---

***At no time should liquid cleaners be applied directly to the amplifier, as direct application of liquids may result in damage to electronic components within the unit.***

---



# U.S. and Canadian Warranty

## 90-Day Limited Warranty

This Proceed® product is warranted to be free from defects in material and workmanship under normal use for a period of ninety (90) days from the date of purchase. **To extend the warranty of this Proceed product**, return the warranty registration card along with a copy of the original receipt of purchase to Madrigal Audio Laboratories, Inc., P. O. Box 781, Middletown, CT 06457.

## Five Year Extended Warranty

The **extended warranty** for this Proceed product is **five (5) years** from the date of purchase. During the warranty period, any Proceed component exhibiting defects in materials and/or workmanship will be repaired or replaced, at our option, without charge for either parts or labor, at our factory. The warranty will not apply to any Proceed component that has been misused, abused or altered.

Any Proceed component not performing satisfactorily may be returned to the factory for evaluation. Return authorization must first be obtained by either calling or writing the factory prior to shipping the component. The factory will pay for return shipping charges only in the event that the component is found to be defective as above mentioned. There are other stipulations that may apply to shipping charges.

There is no other express warranty on this component. Neither this warranty nor any other warranty, express or implied, including any implied warranties of merchantability or fitness, shall extend beyond the warranty period. No responsibility is assumed for any incidental or consequential damages. Some states do not allow limitations on how long an implied warranty lasts and other states do not allow the exclusion or limitation of incidental or consequential damages, so that the above limitation or exclusion may not apply to you.

This warranty gives you specific legal rights, and you may also have other rights which vary from state to state. **This warranty is applicable in the United States and Canada only.** Outside of the U.S. and Canada, please contact your local, authorized Proceed distributor for warranty and service information.

# Obtaining Service

We take great pride in our dealers. Experience, dedication, and integrity make these professionals ideally suited to assist with our customers' service needs.

If your Proceed component must be serviced, please contact your dealer. Your dealer will then decide whether the problem can be remedied locally, or whether to contact Madrigal for further service information or parts, or to obtain a Return Authorization. The Madrigal Technical Services Department works closely with your dealer to solve your service needs expediently.



## **Important!**

---

***Return authorization must be obtained from Madrigal's Technical Services Department BEFORE a unit is shipped for service.***

---

It is extremely important that information about a problem be explicit and complete. A specific, comprehensive description of the problem helps your dealer and the Madrigal Technical Services Department locate and repair the difficulty as quickly as possible.

A copy of the original bill of sale will serve to verify warranty status. Please include it with the unit when it is brought in for warranty service.



## **Warning!**

---

***All returned units must be properly packaged (preferably in their original packing material), and the proper return authorization numbers must be marked on the outer carton for identification. If the packaging to protect the unit is, in our opinion or that of our dealer, inadequate to protect the unit, we reserve the right to repackage it for return shipment at the owner's expense. Neither Madrigal nor your dealer can be responsible for shipping damage due to improper (that is, non-original) packaging.***

---

Your dealer can order a new set of shipping materials for you if you need to ship your component and no longer have the original materials. There will be a charge for this service. We *strongly* recommend saving all packing materials in case you need to ship your unit some day.

# Specifications

*The correlation between published specifications and performance is unreliable. A list of numbers reveals virtually nothing. All technical measurements must be subject to qualitative as well as quantitative interpretation. Measurements of the Proceed amplifier yield excellent results by any standards. However, only those specifications that apply to its actual operation are included here. All specifications are subject to change at any time, in order to improve the product.*

- **Rated power output:** 125 w/ch rms @ 8 $\Omega$ , all channels driven,  
20 Hz–20 kHz with no more than 0.1% THD  
250 w/ch into 4 $\Omega$
- **Frequency response:** within 0.15 dB from 20 Hz to 20 kHz
- **Signal to Noise ratio (main outputs):** better than –80 dB (ref. 1 w)
- **Input impedance:** 100k $\Omega$  (balanced)  
10k $\Omega$  (single-ended)
- **Voltage gain:** 23 dB (balanced)  
29 dB (single-ended)
- **Input sensitivity:** 2.24 V for full rated output (balanced)  
1.12 V for full rated output (single-ended)
- **Power consumption:** less than 150 W in standby  
less than 250 W when fully on and at idle
- **Mains voltage:** determined by the needs of country for which  
the unit was manufactured; cannot be reset by dealer or user
- **Overall dimensions:** See “Dimensions”
- **Shipping weight:** 119 lbs. (54 kg)
- **Connector Complement:** two binding posts per channel  
one 3-pin XLR balanced input connector per channel  
one RCA input connector per channel  
two 1/8" mini-jacks for remote turn-on and loop-through  
two RJ-45 modular connectors for PHAST™ communications  
one IEC AC mains connector
- **Output impedance:** less than 0.05 $\Omega$ , 20 Hz – 20 kHz

For more information, see your Proceed dealer, or contact:

***Madrigal Audio Laboratories, Inc.***

*P.O. Box 781*

*2081 South Main Street (Route 17)*

*Middletown, Connecticut 06457 USA*

*Telephone (860) 346-0896*

*FAX (860) 346-1540*

*Internet <http://www.madrigal.com/>*

*Madrigal provides an owner-transferable, five year extended warranty on all Proceed products within the U. S. and Canada ONLY. Warranty and service policies outside the U. S. and Canada are set by the local, authorized distributor and are applicable in the country of purchase ONLY. Madrigal products are designed to operate at set voltages appropriate for the country of sale and may be damaged if operated at the wrong voltage.*

# Dimensions

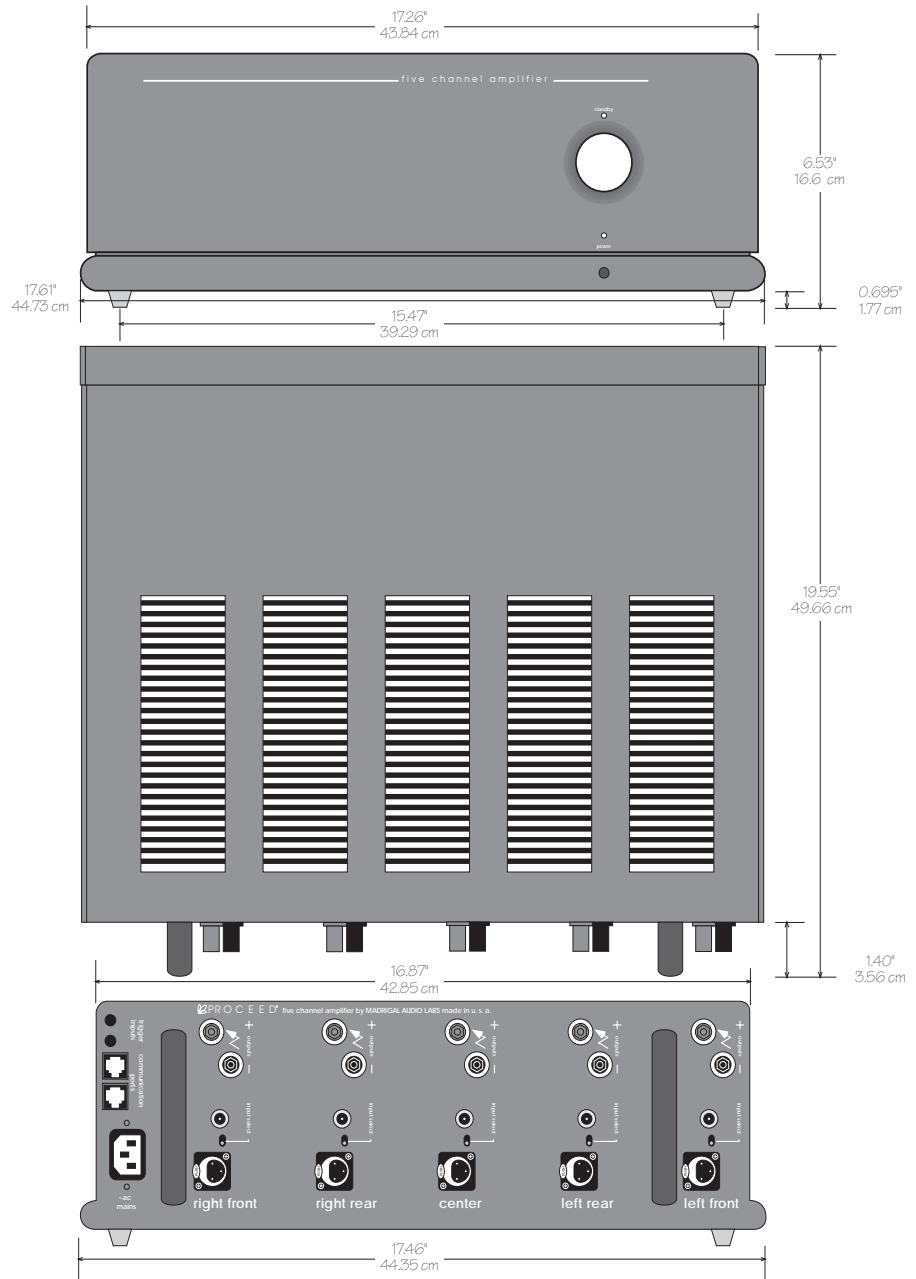

# Rack Mounting

If you need or prefer to rack mount your amplifier, contact your Proceed dealer about the optional rack mount kit. This purpose-designed assembly provides the needed ventilation for the heatsink “chimneys” of the amplifier as well as the support required for this heavy component.

To use the rack mount kit, simply bolt the shelf securely to the rack, slide the amplifier into place, and then mount the provided trim ring around the faceplate of the amplifier (which will protrude from the rack by approximately one inch or 2.5 cm). The drawing below will help you visualize the assembly.

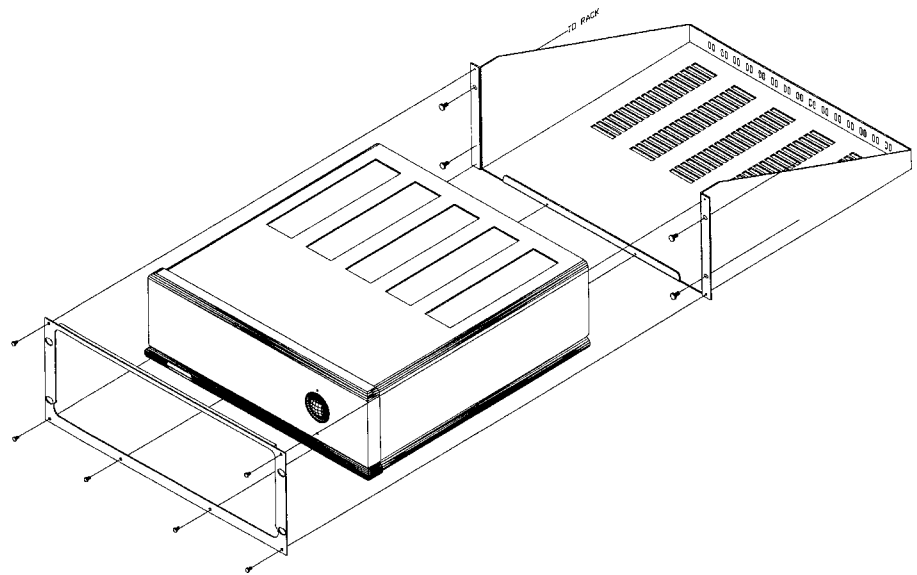

The mounted amplifier and rack mount kit occupies 5 standard rack units of height.



**MADRIGAL**

Madrigal Audio Laboratories, Inc.  
2081 South Main Street, P.O. Box 781  
Middletown, Connecticut 06457 USA

Telephone: (860) 346-0896  
Fax: (860) 346-1540  
<http://www.madrigal.com/>

 **PROCEED<sup>®</sup>**

*is a registered trademark of Madrigal Audio Laboratories, Inc.*  
**H** a Harman International company

## Free Manuals Download Website

<http://myh66.com>

<http://usermanuals.us>

<http://www.somanuals.com>

<http://www.4manuals.cc>

<http://www.manual-lib.com>

<http://www.404manual.com>

<http://www.luxmanual.com>

<http://aubethermostatmanual.com>

Golf course search by state

<http://golfingnear.com>

Email search by domain

<http://emailbydomain.com>

Auto manuals search

<http://auto.somanuals.com>

TV manuals search

<http://tv.somanuals.com>