





**MAGELLAN GPS  
NAV 5000DLX™**

**USER GUIDE**



**Magellan Systems Corporation  
960 Overland Court  
San Dimas, California 91773  
(909) 394-5000  
FAX (909) 394-7050**

22-10134-000



## WARNINGS

A measure of knowledge by the user is required for proper and safe use of the **Magellan GPS NAV 5000DLX™**. READ THE USER GUIDE & WARRANTY COMPLETELY.

### Use Good Judgment

This product is an excellent navigation aid, but it does not replace the need for careful orienteering and good judgment. Never rely solely on one device for navigating.

### Use Care to Avoid Inaccuracies

The Global Positioning System (GPS) is operated by the U.S. Government, which is solely responsible for the accuracy and the maintenance of GPS. Certain conditions can make the system less accurate.



Accuracy can also be affected by poor satellite geometry. WHEN THE ACCURACY WARNING APPEARS ON THE SCREEN, USE THIS DATA WITH EXTREME CAUTION.





THE GLOBAL POSITIONING SYSTEM IS A DoD SYSTEM. The government can make changes to the system that could affect the performance of GPS receivers. Such a change could require a modification to your NAV 5000DLX.



#### WARNING

The accuracy of position fixes can be affected by the periodic adjustments to GPS satellites made by the U.S. Government and is subject to change in accordance with the Department of Defense civil GPS user policy and the Federal Radionavigation Plan.





NOTE: This equipment has been tested and found to comply with the limits for a Class B digital device, pursuant to Part 15 of the FCC Rules. These limits are designed to provide reasonable protection against harmful interference in a residential installation. This equipment generates, uses and can radiate radio frequency energy and, if not installed and used in accordance with the instructions, may cause harmful interference to radio communications. However, there is no guarantee that interference will not occur in a particular installation. If this equipment does cause harmful interference to radio or television reception, which can be determined by turning the equipment off and on, the user is encouraged to try to correct the interference by one or more of the following measures:

- Reorient or relocate the receiving antenna.
- Increase the separation between the equipment and receiver.
- Connect the equipment into an outlet on a circuit different from that to which the receiver is connected.
- Consult the dealer or an experienced radio/TV technician for help.

#### CONVENTIONS USED IN THIS USER GUIDE

This User Guide refers to the NAV 5000DLX's keys in two ways. In general discussion, the keys are referred to by name: for example, the NAV key or the RIGHT ARROW. When describing how to access a feature, these key names are shown in bold type: for example, **NAV** and the **RIGHT ARROW**.

All sample displays that show position coordinates use the default Lat/Lon in degrees/minutes.



## Chapter 1 — the Basics

The NAV 5000DLX.....	1-1
Packing List .....	1-2
The Keys .....	1-2
The Antenna.....	1-3
On/Off .....	1-5
Power-On .....	1-5
Power-Off .....	1-5
Power Warnings .....	1-5
Light.....	1-6
Entering Data .....	1-6
Initialization .....	1-7
Collecting an Almanac .....	1-11
Messages .....	1-12



## Chapter 2 — Function Keys



GOTO .....	2-1
From WPT .....	2-1
From Closest Waypoint .....	2-1
From Waypoint Projection .....	2-1
To an Unnamed Position .....	2-1
From PLOT .....	2-2
From ROUTE .....	2-2
MOB .....	2-2
Navigation (NAV) .....	2-3
Nav1 .....	2-4
Steer .....	2-5
Road .....	2-5
Nav2 .....	2-6
Plot .....	2-6
Position (POS) .....	2-7
The Receiver Activity Display .....	2-8

Displaying a Position Fix .....	2-9
Position Fix Updates .....	2-9
Route .....	2-9
Choosing Leg Switching .....	2-10
Creating a Route .....	2-10
Entering Comments .....	2-13
Activating a Route .....	2-13
Changing to a Different Route/Leg .....	2-13
Viewing a Route .....	2-14
Replacing a Waypoint .....	2-14
Deleting a Waypoint .....	2-15
Inserting a Waypoint .....	2-16
Appending Legs .....	2-16
Reversing a Route .....	2-17
Deleting a Route .....	2-17
Waypoint .....	2-17
Naming a Waypoint .....	2-18
Saving a Position as a Waypoint .....	2-18
Manually Entering a Waypoint .....	2-19
Viewing the Waypoint Catalog .....	2-21
Renaming a Waypoint .....	2-21
Deleting a Waypoint .....	2-21

### Chapter 3 — Auxiliary Functions

AUX 1 — Display Control .....	3-1
AUX 2 — Reverse Route .....	3-2
AUX 3 — Waypoint Projection .....	3-2
AUX 4 — Closest Waypoint .....	3-3
AUX 5 — Alarms .....	3-4
AUX 6 — NMEA Output .....	3-7
AUX 7 — Upload/Download .....	3-7
AUX 8 — Setup .....	3-8
Velocity Average .....	3-9

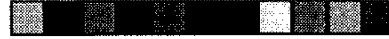

Magnetic Variation .....	3-9
Distance/Speed Units .....	3-10
Coordinate System .....	3-10
Choosing a Leg Switching Mode .....	3-11
Differential Corrections .....	3-14
Altitude Units .....	3-14
Date Order .....	3-14
Internal Beeper .....	3-14
Plot Track .....	3-15
Plot Orientation .....	3-15
Entering an Initial Position .....	3-15
Selecting a Navigation Mode .....	3-17
Date and Time Display .....	3-17
Nav2 Variables .....	3-17
Nav2 Display .....	3-18
Map Datums .....	3-18
AUX 9 - Satellite Status .....	3-19
AUX 10 — Sky Search/Almanac Collect .....	3-21
AUX 11 — Battery Saver .....	3-23
AUX 12 — Erase Waypoints .....	3-24
AUX 13 — Erase Memory .....	3-24

## Chapter 4 — Maintenance and Problem Solving

Batteries .....	4-1
Alkaline Batteries .....	4-1
The Rechargeable Battery Pack .....	4-2
Loading the Batteries .....	4-2
External Power Operation .....	4-4
The DC Power/NMEA Data Cable .....	4-5
The PC Interface Cable .....	4-5
Power Adapters .....	4-7
Error and Warning Messages .....	4-7
Operating Problems .....	4-10



Operating Tips .....	4-17
General .....	4-17
Unsure of Your Position When Initializing .....	4-17
Initialization Errors .....	4-18
The Signal Environment .....	4-18
Choosing a Datum .....	4-19
Storing the Unit .....	4-20
For More Than 3 Months .....	4-20
For Less Than 3 Months .....	4-20
When Nothing Else Works .....	4-21
Magellan's Customer Support .....	4-21

## Appendices

1 Global Positioning System .....	A-1
How GPS Works .....	A-1
Accuracy .....	A-2
Differential GPS .....	A-2
Monitoring and Controlling GPS .....	A-3
GPS Information Sources .....	A-4
2 Specifications .....	A-5
3 Table of Constants .....	A-7
4 Waypoint Log, Lat/Long .....	A-13
5 Waypoint Log, UTM .....	A-15
6 Waypoint Log, TD .....	A-17
7 Glossary .....	A-19

The NAV 5000DLX is easy to use, but there are a few things you need to know to operate it. This chapter describes the unit and then discusses operating procedures such as turning the unit and the backlight on, getting signals with the antenna, data entry and edit, and interpreting the message displays that appear on the screen during normal operation.

### **THE NAV 5000DLX**

The NAV 5000DLX is a powerful, handheld aid to navigation that allows you to take advantage of the most advanced navigation tool available — the Global Positioning System.

The NAV 5000DLX collects data from the GPS satellites on five channels to compute position (using Lat/Lon, UTM, or TD coordinates), elevation, and velocity and navigation data. This information is updated every second.

The NAV 5000DLX's memory can hold up to 1000 user-entered waypoints plus 20 routes with up to 20 legs each. All routes can be reversed. In addition, the NAV 5000DLX has a man overboard function and a Go-To function. Man overboard marks the position of an incident and establishes a route from the present position back to the site. Go-To establishes a 1-leg route from the present position to any selected position.

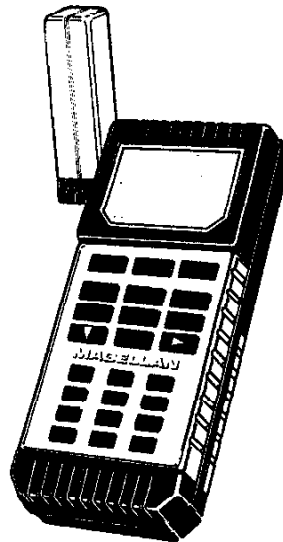



The NAV 5000DLX can also use broadcast data from the U.S. Coast Guard DGPS beacons to calculate and display differentially corrected position fixes. This allows you to overcome the effects of Selective Availability, which introduces errors into the positioning data. (Selective Availability and differential positioning are described in *Appendix 1*.) To take advantage of this feature, the NAV 5000DLX must be connected to a compatible Differential Beacon Receiver such as the Magellan DBR™.

The NAV 5000DLX was developed primarily for marine use. It supports most devices that conform to NMEA (National Marine Electronic Association) standards 0180 and 0183. This includes devices such as autopilots, plotters, radars, and sounders.

### PACKING LIST

---

When you receive your NAV 5000DLX, you should have all of the following:

- the Magellan NAV 5000DLX
- one battery clip, installed
- six batteries, installed
- DC Power/NMEA Data Cable
- one lanyard
- unit holder, with bracket
- 6' antenna extension cable
- antenna suction cup mount
- Field Card
- this guide

If any of these items is missing, contact your Magellan dealer.

### THE KEYS

---

The NAV 5000DLX has three types of keys: function keys, operation keys, and alphanumeric keys. The function keys are the eight center keys at the top of the unit. These keys are used

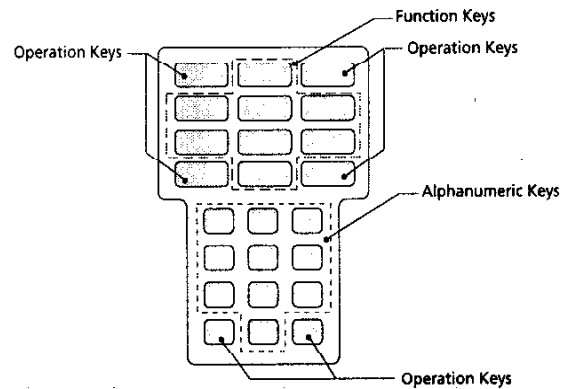

to access the unit's features. The operation keys are the four keys in the corners of the top keypad, plus the ENTER and CLEAR keys at the bottom of the alphanumeric keypad. They are used to turn the unit and backlight on and off, to scroll through information displays, and to save or delete information. The alphanumeric keys are used to input information and, when used with the AUX key, to access the auxiliary features.

Detailed information relating to specific function keys is found in Chapters 2 and 3.

## THE ANTENNA

The antenna must have a clear view of the sky to receive satellite signals, and will operate best when in an upright position. GPS uses "line of sight" microwave signals to locate and track satellites. If the signals are obstructed by dense objects such as people or structures, the unit will not operate properly. (Canvas, glass, plexiglass, and many plastics are normally transparent to satellite signals.)

The detachable antenna can be used while mounted on the unit or it can be removed and attached to the unit with the extension cable (provided) and mounted wherever it has a clear view of the sky.

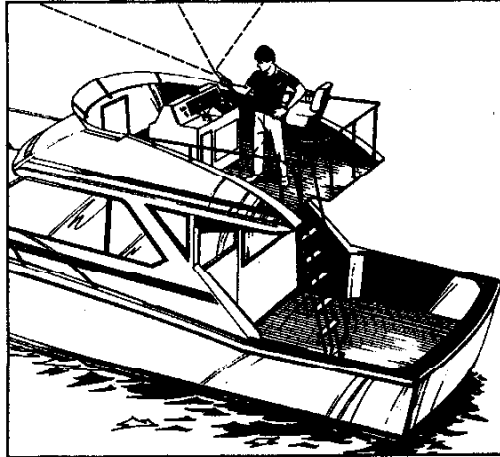

#### Give the Antenna a Direct View of Satellites

To use the antenna while mounted on the unit, hold the unit at a comfortable angle and rotate the antenna until it is vertical; the antenna must be used in a vertical position to get the best signal possible.

The unit's antenna is unlikely to get signals when operating in a covered location (such as a navigation station) unless it is removed from the unit and temporarily mounted to any reasonably flat surface that has a clear view of the sky. If the covered location is your usual operating station, you may prefer to connect the unit to the optional external antenna.

#### NOTE

If your signal appears to be blocked, sometimes moving a few feet in any direction will let you receive a signal. This is especially true in areas of dense or overhanging vegetation or structures.

To detach the antenna from the unit, rotate the antenna counterclockwise from the 6 o'clock (down) position to the 8 o'clock position. (You will feel some resistance at 11 o'clock.)

Pull the antenna away from the unit. Attach the extension cable to the antenna and the unit and insert the antenna into the suction cup mount. Mount the antenna (in a vertical position with the cable end down) where it has a clear view of the sky.

## ON/OFF

The NAV 5000DLX is turned on and off by pressing the red POWER key at the top left of the keypad.

**Power-On.** The NAV 5000DLX performs a self-test each time it is turned on. The self-test starts when the unit identifies the power source being used (battery or external power). Immediately after the self-test is completed, the unit begins to search for satellites, as described in *Position (POS)*.

**Power-Off.** The NAV 5000DLX is turned off by pressing the ON/OFF key while the unit is operating. This initiates a 5-second countdown, which is displayed on the screen.

--WARNING--  
POWER OFF IN  
5 SECONDS  
PRESS ANY KEY TO  
ABORT

When the counter reaches 0 seconds, the unit turns off. The countdown can be interrupted and the unit returned to normal operation at any time by pressing any function key before 0 seconds is displayed.

If you prefer, you can turn the unit off immediately by pressing ON/OFF a second time.

**Power Warnings.** The NAV 5000DLX displays three power warnings to alert you to changes in the status of the power source being used.

When operating from battery power, a battery icon appears on all displays when the batteries become low. Generally, the unit can still operate for about 30 continuous minutes when the battery icon appears.

Another battery warning is displayed when the batteries no longer have enough power to operate the unit. When the full-screen message "REPLACE BATTERIES OR LOSE MEMORY" is displayed, the unit can no longer be operated from battery power. (The unit will automatically turn itself off 2 minutes after this warning appears.) The batteries should be able to maintain the unit's memory for up to one month, but cannot be used to operate the unit.

The third power warning is displayed when the external power being supplied to the unit falls below minimum requirements. The unit will turn itself off 2 minutes after "EXTERNAL POWER LOST" appears. You may continue to operate from battery power by pressing any function key before power-off.

## LIGHT

---

The LIGHT key controls the display backlight. Press LIGHT to turn the backlight on and off.

The light will turn off automatically when the unit is turned off. It also turns off when the second battery warning appears and when external power is lost.

The brightness and contrast of the display when the light is on can be modified with AUX 1.

### NOTE

The light is a significant drain on your batteries when operating from battery power.

## ENTERING DATA

---

Information must be keyed into the unit from the alphanumeric keypad to enter an initial position, to manually enter a waypoint, or to name or retrieve a waypoint.

Each alphanumeric key is assigned to a number and two or three letters. To enter position coordinates, simply press the appropri-

ate alphanumeric keys until the entire coordinate is entered; if entering Lat/Lon coordinates, use the RIGHT ARROW to toggle between hemispheres. Press ENTER to save the first line of the coordinate. Trailing zeros can be entered by pressing the 0 key or by entering the coordinate up to the zeros. When ENTER is pressed, the remainder of the coordinate will be filled with zeros.

If you pressed the wrong key (and ENTER has not been pressed yet), press CLEAR and press another key.

Waypoint names consist of up to five alphanumeric characters, preceded by a user-selected icon. A plus (+) is automatically displayed at the start of the waypoint name; press the RIGHT ARROW to scroll through □, △, ▽, and back to +. (These icons are used to represent the waypoint on the plotter display.) When the desired icon is displayed, press an alphanumeric key, then press the RIGHT ARROW until the desired character is displayed. Press the next alphanumeric key and continue until the waypoint name has been completed, then press ENTER.

## **INITIALIZATION**

Initialization means telling the unit where it is (approximate coordinates and elevation), and the current date and time. If necessary, you will also collect an almanac. (Collecting an almanac is described in the next section.)

Once the unit has been initialized correctly, it will not have to be re-initialized unless you clear the memory or move the unit more than 300 miles from its last known position fix.

It is possible to use the unit without first initializing it, but the unit will have to initialize itself before it can provide a position fix. The unit requires about 15 minutes to self-initialize and compute a first position fix because it must initiate Sky Search to collect an almanac and determine its location. When the unit has been initialized by you, the time to first fix is only about 55 seconds.

To initialize, you must know your coordinates within 300 miles (480 km). You should also know your elevation as accurately as possible. (Normal tidal fluctuations do not affect this measurement.)

If you do not know your coordinates, call your local marine electronics dealer or consult an atlas or chart. You can use the coordinates of any landmark that is within 300 miles of your position.

We recommend that you read *AUX 8 — SETUP* in Chapter 4 to fully customize your unit. This section is intended to provide only enough information to set the initial position.

The NAV 5000DLX can display coordinates in Lat/Lon as degrees/minutes (34°06.560N) or degrees/minutes/seconds (34°06'34N), in UTM, or TDs. Default is Lat/Lon in degrees/minutes; to initialize in any other format, you must first use AUX 8 to select that format. The unit will accept coordinates only in the displayed format.

Press **AUX, 8, ENTER**, then press the **DOWN ARROW** until 12) INITIAL POS is displayed and press **ENTER**.

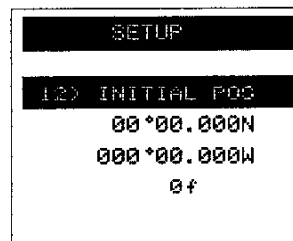
**NOTE**

Do NOT use the coordinates in this sample as your initial position.

Press **ENTER** to key in latitude.

Position coordinates are entered by pressing the appropriate keys on the 10-key keypad, pressing the **RIGHT ARROW** to select hemisphere (Lat/Lon coordinates only), then pressing **ENTER**. Trailing zeros can be entered automatically by keying in the coordinates up to the first zero, then pressing **ENTER**.

**NOTE**

The default hemispheres (before initialization or after memory loss) for Lat/Lon position coordinates are North and West. The unit assumes that the hemispheres you choose here (or the hemispheres of the last position fix, whichever is more recent) are current. These hemispheres are offered as your first choice when you enter a waypoint manually.

Enter the longitude; use the **RIGHT ARROW** to toggle between E and W (if necessary), then press **ENTER**.

**WARNING**

You **must** know your position within 300 miles (482.7 km). If you do not know your position, press AUX 10 or POS to initiate Sky Search.



Now enter your current elevation. (Entering an accurate elevation here will allow the unit to operate more accurately.) The default elevation is 0 feet (mean sea level). If you are currently at sea level, do nothing. To enter a different elevation, press **CLEAR**, then key in the correct elevation. (Use the **RIGHT ARROW** to toggle between positive and negative values.) Press **ENTER** to save the value entered.

```

SETUP
12) INITIAL POS
    34 °00.000N
    117 °00.000W
      + 2f
      ↓
  
```

**NOTE**

If you will be using an external antenna be sure to enter antenna elevation. Antenna elevation is elevation (*your* height above sea level) plus the height for the antenna installation above you.

If no elevation is entered, the unit assumes that elevation is 0.

Next, select a mode of operation. Press the **DOWN ARROW** to highlight "MODE" and press **ENTER**.

```

SETUP
13) MODE
  2D  3D  AUTO
14) DATE & TIME
  DATE      MDY
  TIME      UTC
      ↓→
  
```

The default mode of operation is 2D, which is recommended for maritime use. Press the **RIGHT ARROW** to display the mode of operation you want to use.

**NOTE**

The NAV 5000DLX is shipped with an almanac. You should therefore have no difficulty getting your first position fix once the unit has been properly initialized.

The unit updates the almanac (and updates its clock) whenever it is tracking satellites. But unless the unit is on and tracking satellites for at least 10 minutes, only part of the almanac can be refreshed in this way. If the unit is in frequent use for 10-minute periods (or longer), it should always have up-to-date almanac information.

When the unit has not been used for more than a few minutes recently (generally, in six months or more), its almanac may be out of date. The almanac may also be out of date if the GPS system operators have changed the status of a satellite. The unit can still obtain a position fix, but it may take a little longer than usual to locate satellites.

Collect a new almanac at any time by pressing AUX 10 to initiate Sky Search.

**NOTE**

Once a satellite signal has been located, it takes about 12-1/2 minutes to collect a complete almanac.

**MESSAGE DISPLAYS**

The NAV 5000DLX displays a variety of message icons during operation. They are intended to alert the operator to an existing condition.

- **Geometric Quality** — Appears when the Geometric Quality (GQ) of a position fix falls to 3 or below. The position fix may not be accurate enough to be depended on for navigation. May be overridden by the Old Data icon.

- 
- ☰ **Signal Quality** — Appears when the Signal Quality (SQ) of a position fix falls to 3 or below. The strength of one or more satellite signals is weak, and the receiver may lose its lock on it. This has a minimal effect on accuracy, and is intended only to alert the user that a signal may be lost.
  - **Differential Correction** — A differential correction has been applied to the position displayed. This icon is not stored when a position is saved as a waypoint.
  - **Battery Warning** — Appears when the batteries are low and should be replaced. This is the first battery warning; when it is displayed, the unit can be operated for a limited length of time before the second battery warning appears.
  - ⊠ **Old Data** — Appears when the unit has been unable to compute and display a position fix update for the past 10 seconds. This occurs when the signal from one or more satellites is lost and the unit has been unable to recover the signal. The position fix that is displayed is at least 10 seconds old, and should not be used for navigation.
- Now 2D** — Appears for a few seconds on power-on when the unit has been set to 2D operation. It also appears briefly during Automatic operation when the unit switches from 3D operation to 2D.
- Now 3D** — Appears for a few seconds on power-on when the unit has been set to 3D operation. It also appears briefly during Automatic operation when the unit switches from 2D operation to 3D.
- ➔ **Right Arrow** — Appears in the SETUP function and during data entry to indicate that additional options are available. Appears in the ROUTE and AUX functions to allow the user to toggle through additional information at any time. Also used to change the display scale for the CDI and Plot display.

- ↓ **Down Arrow** — Appears on most function displays to indicate the presence of additional information screens. In SETUP and AUX, indicates additional SETUP and AUX features. In WPT, indicates additional waypoints.
- Alm Clct** — Appears when the unit is collecting an almanac. Do not turn the unit off while this message is displayed.
- Alm Verfy** — Appears when the unit is verifying the almanac information it just collected. Immediately follows Almanac Collect. Do not turn the unit off while this message is displayed.
- Sky Srch** — Appears when the unit is searching the sky for satellites in order to collect an almanac.
- ⚓ Appears on all displays when the anchor alarm is on.
- ⌚ Appears on all displays when the arrival alarm is on.
- X Appears on all displays when the cross track error alarm is on.
- P Appears on all displays when the proximity alarm is on.

The function keys are used to operate the 5000DLX. They are described in alphabetical order.

### GOTO

The GOTO key allows you to establish a 1-leg route from the present position to any stored waypoint or to unnamed position coordinates. It is used in conjunction with other function keys.

**From WPT.** Display a stored waypoint from the waypoint catalog, then press GOTO.



**From Closest Waypoint.** Highlight the desired waypoint from the closest waypoint list and press GOTO.

**From Waypoint Projection.** While displaying the projected position, press GOTO. The unit will compute and display a Go-To route to the projected position.

**To an Unnamed Position.** You can create a Go-To route to any position coordinates you enter.



Press GOTO from any display except Waypoint, Waypoint Project, Closest Waypoint, or Plotter. Enter the coordinates of the desired destination.

**From PLOT.** A Go-To route can be set to any waypoint that is displayed on the Plot screen. Highlight the desired waypoint by pressing the DOWN ARROW. Press GOTO; the unit will display a new course line and destination.

**From ROUTE.** A Go-To route can also be created from the route catalog. Refer to *Route* to create or edit a Go-To route from the route catalog.

## MOB

The man overboard (MOB) function is used in an emergency to immediately save the current position and to provide navigation data to return to that position. The coordinates of the MOB position are also displayed so they can be relayed to the Coast Guard or local authorities.

If you are navigating on a route when MOB is pressed, the current route is deactivated.

Press **MOB**. The unit saves the current position as waypoint+mob and displays the waypoint's coordinates. It also creates a route to waypoint +mob, and displays SOG, COG, bearing/distance to +mob, a CDI or VMG bar (as selected in SETUP for NAV2).

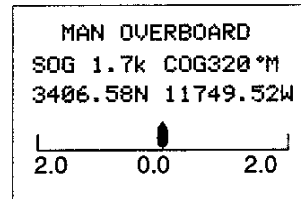

To stop navigating on the MOB route, activate a different route.

**NOTE**

All NAV displays and the PLOT screen are available when using the MOB function.

Waypoint +mob can be accessed in the waypoint catalog and used in other routes. This waypoint will be overwritten the next time MOB is pressed.

If you press **MOB** while a waypoint +mob already exists, the unit displays a warning. The bottom line displays the number of hours since MOB was last activated; the counter stops when it reaches 99.99 hours.

```

MAN OVERBOARD
--WARNING--
YOU ARE ABOUT TO
REPLACE MOB
CONTINUE ■■■ PRESS MOB
ANY OTHER KEY TO
ABORT 00:00 OLD
  
```

To replace waypoint +mob with a new position, press **MOB** again. Press any function key except **ROUTE** to abort.

There is one major difference between the MOB route and the Go-To route. The Go-To route has a fixed FROM-waypoint. The FROM-waypoint of a MOB route is always the current position, which is updated with each position fix update. The navigation information provided is always referenced to the updated position in relation to waypoint +mob.

## NAVIGATION (NAV)

The NAV key provides both navigation (heading, bearing, distance) and velocity (speed over ground) information.

Navigation information is available only when waypoints and a route have been entered and the route has been activated.

Velocity information is available whether a route is active or not, as long as you are traveling at least 0.2 knots. Since velocity-related information is based on instantaneous speed, you may

notice some fluctuation in the values displayed. This effect can be "smoothed" by using velocity average to substitute a weighted average for the instantaneous measurement. (Refer to *AUX 8 — SFT/JP.*)

If you are navigating on a route, three messages are displayed at the bottom of the screen that indicate how close you are to the TO-waypoint: CLOSE, ARRIVED, and COMPLETE. (Refer to *Choosing a Leg Switching Mode* in Chapter 3 during this discussion.) CLOSE is displayed when you enter the arrival circle around the leg's destination. If the leg switching mode is set to manual, the unit displays ARRIVED when the perpendicular that intersects the TO-waypoint is crossed. (If the leg switching mode is set to automatic, crossing this line causes the unit to switch legs.) At the end of the route, when you enter the arrival circle of the route's destination, the unit displays COMPLETE.

Information is provided on four navigation screens; Nav1, Steer, Road, and Nav2. (Some NAV information can also be displayed on the PLOT screen.)

**Nav1.** The Nav1 display shows basic navigation information in large characters.

Press **NAV**. The unit shows COG, SOG, bearing and distance to the TO-waypoint, and a course deviation indicator (CDI) that graphically displays your cross track error.

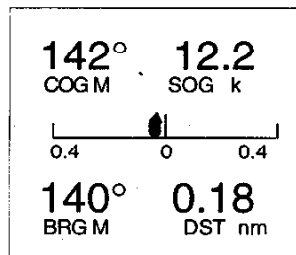

The CDI scale can be changed by pressing the RIGHT ARROW. Select 0.2, 0.4, 1.0, 2.0, 4.0, or 8.0 distance units. (Each marker is 1/4 of the scale you select.) The distance unit used is the one selected in SETUP. The courseline is always at the center of the CDI. The boat icon is your current position in relation to the courseline. (For example, it is to the right of center when you are to the right of the courseline.)



**NOTE**

Cross track error cannot be computed when you are 9.99 nautical miles or more from the courseline. If this occurs, the unit will display "INVALID LEG" and the boat icon will be at the far side of the CDI.

In addition, the boat icon rotates to indicate your current steering angle in relation to the courseline. If your steering angle is 30° away from the courseline, the boat icon will be rotated 30° away from the center. If your steering angle is 90° or more away from the courseline, the boat icon will be perpendicular to the courseline.

**Steer.** The Steer display is a graphical representation of angular measurements in relation to your current heading.

Press **NAV** from the Nav1 display. The unit displays a semicircle that is labeled with your current COG. The top of this semicircle is always the direction you are currently travelling. The cursor next to the semicircle shows the angle toward the TO-waypoint; when you are on course, the cursor will be displayed at the top of this semicircle. The center of the display shows the compass points relative to the TO-waypoint and your current bearing to the TO-waypoint.

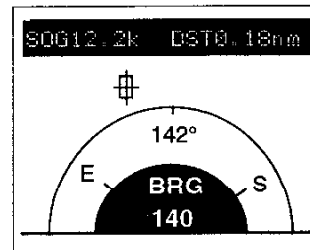

**Road.** The Road display is a graphic variation of the CDI, in which the courseline is represented as a road and the width of the screen represents 300 meters. The boat icon represents the current position in relation to the courseline.

Press **NAV** from the Steer display. The name of the destination waypoint is shown above the road, with distance to the waypoint and bearing at the top of the display. Current SOG and COG are below the road.

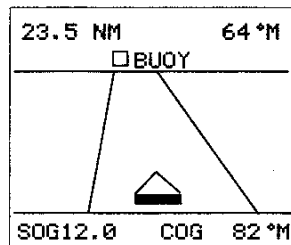

The display is centered on the boat icon, which is stationary. The road moves to show the course line in relation to the current position. If the cross track error is too large to be displayed and an arrow appears to indicate the necessary steering correction.

**Nav2.** Nav2 is a user-defined navigation display that resembles the Nav1 display. You may select four of the following parameters: COG, SOG, bearing, distance, VMG, ETA, TTG, SOA, XTE (with R and L to indicate direction of the error), DMG, and steering. Which parameters are displayed is selected in SETUP.

You may also display either a CDI or a VMG bar. The VMG bar is a hollow horizontal bar that fills from left to right to indicate VMG divided by SOG as a percentage. This is also selected in SETUP.

To display Nav2, press **NAV** from the Road display.

## PLOT

Plot is a graphic overhead view of your current position represented by a boat icon at the center of the display and the waypoints that can be seen at the current display scale. If a route is active, to TO-waypoint of the current leg and related navigation information is also shown.

Other plot features can be changed to customize the display. Track (the actual course travelled), for example, can be turned on and off in Setup; when on, track can be shown for the last 10 minutes, 1 hour, 2 hours, 12 hours, or 24 hours.

You may also select either a North-up or a COG-up display orientation in Setup. When North-up is selected or if you are not moving (regardless of the orientation selected), the boat icon rotates to indicate the direction of COG (heading). When COG-up is selected and a route is active, the boat icon points to the top of the display.

Press **PLOT**. The unit displays the SOG and COG, the courseline for the current route leg, and your position in relation to that leg. It also displays range and bearing from the current position to the TO-waypoint, plus all stored waypoints that are within range of the selected plot scale.

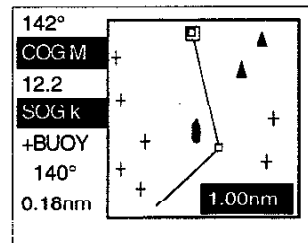

The current plot scale is shown in the lower right corner. The display scale is changed by scrolling through 1, 5, 10, 50, 100, and .25 distance units (the units are the ones selected in SETUP). The larger the number, the greater the area that is shown on the display. Press **2** to increase the scale and **1** to decrease the scale.

To display range and bearing to any of the displayed waypoints, press the **RIGHT/DOWN ARROW** until the desired position is highlighted on the plot display. Each time an arrow is pressed, the name of the highlighted waypoint is displayed on the left, along with distance and bearing.

You may highlight any waypoint to use as a Go-To destination. This is described in *GOTO*.

## **POSITION (POS)**

The NAV 5000DLX automatically computes and displays a position fix once the self-test portion of the power-on sequence

is complete. If another function is accessed before the fix is computed, the fix will be computed but will not be displayed.

The POS key is used to return to the position display after using another feature.

**The Receiver Activity Display.** When the unit is first turned on, it checks its almanac for satellite availability (given your initial position or last fix), then begins to search for satellites on all five channels.

The search can be visually monitored on the receiver activity screen, which is displayed automatically. Satellites that are being tracked or searched for are listed on the left. The strength of the satellite signal (SQ) is indicated by the bar; the longer the bar, the higher the SQ.

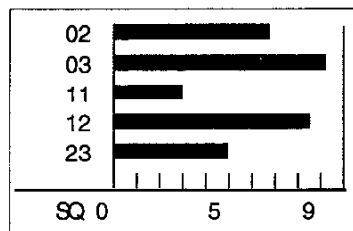

**NOTE**

If the NAV 5000DLX does not have a current almanac or has not been operated for more than a few minutes in the past six months, the unit enters Sky Search to locate a satellite, collect a current almanac, and self-initialize before calculating a position fix. (Refer to *▲UX 10 — Almanac Collect.*)

The receiver activity screen is displayed until ephemeris data has been collected from enough satellites to compute a position fix (given the operation mode selected).

**Displaying a Position Fix.** A position fix is displayed as soon as it is calculated (unless another feature is accessed before the fix is obtained). If the unit was initialized correctly, the first position fix (cold start) can be made in 55 seconds or less. If the previous fix was made in the last hour and you are using the same set of satellites (warm start), subsequent first position fixes can be made in about 30 seconds.

The POS screen displays the present position in the currently selected coordinate system, elevation, current time and date, and the GQ of the fix.

The receiver activity screen can be displayed at any time by pressing **POS** while the position screen is being displayed. Press **POS** again to return to the position display.

POSITION	
34 °06.576N	
117 °49.567W	
0f 08/30/94	
19:00:58UT	GQ=9

Pressing **POS** from any other function or feature will always display the current position.

**Position Fix Updates.** The position fix is normally updated approximately once every second, unless a satellite sets or its signal becomes blocked.

When the unit loses a satellite signal, it tries to locate the signal again. If the signal cannot be relocated, the satellite signal is replaced with another one. This rarely takes more than 10 seconds, but if it does, the most recent information is displayed with an Old Data symbol (⌘) on the last line.

## ROUTE

A route is a planned course of travel from one place to another. It is defined by a waypoint at the starting position (the FROM-waypoint) and another at the destination (the TO-waypoint).

In addition, routes are often broken into smaller segments, called "legs." Each leg has its own TO- and FROM-waypoints, but the TO-waypoint of one leg is also the FROM-waypoint of the next leg. Using legs makes it easier to plan a route that may include several starts and stops, such as travelling from one fishing spot to another.

The NAV 5000DLX can store up to 20 routes of as many as 20 legs each. All routes can be activated, edited, deleted, or reversed.

**Choosing Leg Switching.** A route can be followed using the automatic leg switching or manual leg switching mode. (Automatic is the default.) Which mode is selected determines whether the unit switches route legs automatically or if the user must switch legs manually. It does not affect the navigation displays.

The leg switching mode is selected in SETUP, and is described more fully in *AUX 8 — SETUP*.

**Creating a Route.** A route is created by deciding where your start position will be, where you want to go, the best way to travel from start to destination, and then defining the planned route with waypoints that are stored in the unit's memory.

Any waypoint can be used in more than one route, and may also be used more than once in the same route.

Press **ROUTE**. The unit displays GOTO and the first four route records. (The Go-To route can be accessed with the ROUTE key as well as with the GOTO key. Creating a Go-To route is described in *GOTO*.)

```

ROUTE
RTE___
GOTO  EMPTY ROUTE
RTE 1  EMPTY ROUTE
RTE 2  **COMMENTS**
RTE 3  **COMMENTS**
RTE 4  EMPTY ROUTE
      ↓
  
```

**NOTE**

Entering and using routes **requires** that waypoints already be stored in the unit's memory.

Press the **DOWN ARROW** to highlight an empty route record and press **ENTER**. If you prefer, key in the desired route number and press **ENTER**. If there is not empty record, you must delete an existing route before continuing. (Refer to *Deleting a Route*.)

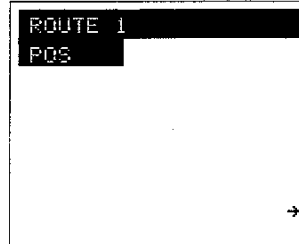

A screenshot of the device's screen. The top line is labeled 'ROUTE 1' and the second line is labeled 'POS'. A black bar highlights the 'POS' option. A right-pointing arrow is visible in the bottom right corner of the screen area.

POS is the first option for any TO- or FROM-waypoint until it is used in the route. When POS is selected, the present position is saved as waypoint +strxx, where "xx" is the number of the route being created, and POS is not displayed as an option again.

To use POS, press **ENTER**. (Remember that if you have moved since the unit was last used, POS is no longer the current position.) To use a waypoint, press the **RIGHT ARROW** to scroll through the waypoint catalog, or key in the name of the desired waypoint followed by **ENTER**. Press **ENTER** when the desired waypoint is displayed.

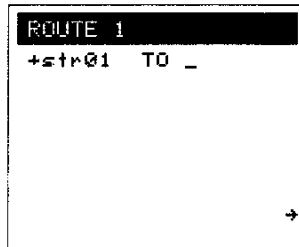

A screenshot of the device's screen. The top line is labeled 'ROUTE 1' and the second line is labeled '+str01 TO \_'. A black bar highlights the '+str01 TO \_' option. A right-pointing arrow is visible in the bottom right corner of the screen area.

Next, select the TO-waypoint for the first leg. Press the **RIGHT ARROW** to scroll through the waypoint catalog. If POS has not already been used, it will be displayed at the head of the catalog. Waypoint +strxx will not be displayed as part of the catalog; +strxx can be accessed only with the WPT key, and can be used only once in a route. If you know the name of the desired waypoint, key it in and press **ENTER**. Press **ENTER** again when the waypoint is displayed.

**NOTE**

If you decide not to continue entering this route, you can abort **before** the first leg is completed by pressing any function key to exit the ROUTE function. Once the first leg is completed by pressing ENTER, the unit automatically saves each leg as it is completed.

Once **ENTER** is pressed, the unit continues with the next leg. You will select only a TO-waypoint for this leg; the unit always uses the TO-waypoint of the previous leg as the FROM-waypoint of the current leg.

```
ROUTE 1
+TUNA TO _

```

When all of the legs have been entered, press **ENTER** again. The unit computes and displays distance/bearing for each leg and of the entire route (from the first FROM-waypoint to the last TO-waypoint).

```
ROUTE 1 28.00 NM
+str01 TO ΔTUNA
328° 3.56
ΔTUNA TO ∇PORT
118° 18.77 nm
∇PORT TO □DOCK
043° 5.67 nm

```



You must activate the route you just created in order to navigate on it. Be sure that the first leg you want to navigate on is highlighted, then press **NAV**.

**Entering Comments.** A descriptive comment can be entered at any time for a defined route. The comment is displayed as part of the route catalog.

A comment is entered after the route has been created by displaying the route catalog, highlighting the desired route, and keying in up to 12 characters. (Since a blank space is not available, try using a hyphen to separate words.) Press **ENTER** to save the comment.

If no comment is entered, the unit displays "\*\*\*COMMENTS\*\*" next to the route number.

**Activating a Route.** Any route must be activated in order to display navigation information relating to your progress along that route.

The exception is the Go-To route, which is activated automatically when created.

To activate a route, press **ROUTE** and use the **DOWN ARROW** to highlight the desired route. Press **ENTER**.

Scroll through the route with the **DOWN ARROW** until the desired leg is the first leg on the screen. Press **NAV**. The selected route is activated, with the displayed leg becoming the current leg.

**Changing to a Different Route/Leg.** To activate a different route, press **ROUTE** and select a new leg or a new route/leg, then press **POS** or **NAV**.

If you are supporting an NMEA device, the device should be turned off or put into standby before selecting a different route or leg. After the new route/leg is selected, reactivate the device.

**Viewing a Route.** A route can be viewed at any time by pressing the route key, highlighting a route, and pressing ENTER.

Press **ROUTE** and use the **DOWN ARROW** to select a route, or highlight "RTE\_\_" and key in the number of the desired route, followed by **ENTER**.

Press **ENTER** again. Use the **DOWN ARROW** to scroll through the legs.

**Replacing a Waypoint.** Routes can be edited in four ways; by replacing one waypoint with another, by deleting a waypoint, by adding a waypoint, and by appending new legs to the end of the route. This section describes how to replace one waypoint with another.

First, access the route as described in *Viewing a Route*. Use the **DOWN ARROW** to highlight either of the two legs in which the waypoint you want to change appears. Press the **RIGHT ARROW** to highlight the waypoint.

```
ROUTE 1 30.33 NM
ΔTUNA TO ▽PORT
118° 18.77 nm
▽PORT TO □DOCK
043° 5.67 nm
↓→
```

**NOTE**

It does not matter if the waypoint highlighted is the TO- or FROM-waypoint; the unit will automatically change the waypoint at both positions.

Press any alphanumeric key. The highlighted waypoint is replaced by a cursor.

```
ROUTE 1 30.33 NM
ΔTUNA TO _
118° 18.77 nm
TO □DOCK
↓→
```

Select an icon and key in the name of the new waypoint, or press the **RIGHT ARROW** to scroll through the waypoint catalog. Press **ENTER** when the desired waypoint is displayed. The unit will replace the deleted waypoint and its match in the previous/following leg. The unit will also recompute bearing and distance for the changed legs and the route.

```

ROUTE 1 21.70 NM
ΔTUNA TO ΔMARLN
118° 18.77 nm
ΔMARLN TO ΔDOCK
061° 9.47 nm
↓→

```

This edit is saved automatically.

**Deleting a Waypoint.** Deleting a waypoint has the effect of shortening the route by one leg.

Access the route as described in *Viewing a Route*. Use the **DOWN ARROW** to highlight either of the legs in which the waypoint appears. Press the **RIGHT ARROW** to highlight the waypoint.

#### NOTE

Highlight the desired waypoint at the the TO- or FROM-waypoint position.

Press **CLEAR**. The unit removes the highlighted waypoint from both legs, combines the legs into one, and recomputes the bearing and distance for this leg and for the route.

```

ROUTE 1 28.00 NM
+str01 TO ΔTUNA
320° 3.56
ΔTUNA TO ∇PORT
118° 18.77 nm
∇PORT TO ΔDOCK
043° 5.67 nm
↓→

```

This edit is saved automatically.

**Inserting a Waypoint.** Inserting a waypoint into the middle of a route has the effect of creating an additional leg.

Access the route as described in *Viewing a Route*. Use the **DOWN ARROW** to highlight the leg in which the new waypoint will be inserted. Press the **RIGHT ARROW** to highlight either the TO- or FROM-waypoint.

Press **ENTER**. The unit divides the leg in two between the TO- and FROM-waypoints by inserting a blank for a new TO/FROM-waypoint.

```

ROUTE 1 28.00 NM
+str01 TO -
          TO ∇PORT
    118° 18.77 nm
∇PORT TO □DOCK
    043° 5.67 nm
          ↓↔
  
```

Highlight either blank. Select a waypoint by entering all or part of a waypoint name or by using the **RIGHT ARROW** to scroll through the waypoint catalog. Press **ENTER** when the desired waypoint is displayed. The new waypoint is inserted

```

ROUTE 1 21.70 NM
+str01 TO □MARLN
    121° 8.77
□MARLN TO ∇PORT
    061° 9.47 nm
∇PORT TO □DOCK
    043° 5.67 nm
          ↓↔
  
```

into both blanks, distance and bearing for the two legs are computed, and distance and bearing for the route is recomputed.

This change is saved automatically.

**Appending Legs.** New legs can be added to the end of any route that has fewer than 20 legs.

To append a leg, select a route and highlight the TO-waypoint of the last leg. Press **ENTER**.

The unit adds a new leg. Select a TO-waypoint for the new leg and press **ENTER**. Continue adding legs until all additions have been made or until the 20-leg limit is reached. Press **ENTER** again to recompute and display bearing/distance information.

**Reversing a Route.** Reverse Route is an auxiliary function (AUX 2) that allows you to reverse the waypoint order of any route. This means that you can navigate from one place to another, reverse the route, and navigate back to your original starting point without manually entering a new route for the return trip.

Refer to *AUX 2 — Reverse Route* in Chapter 5.

**Deleting a Route.** Delete routes as they are no longer needed.

To clear a route, press **ROUTE** and highlight the desired route. Press **CLEAR**. The unit displays "PRESS CLEAR" in the comment field. Press **CLEAR** again to delete the route, or press any function key to abort.

## WAYPOINT (WPT)

A waypoint is the coordinates for a specific position or location that has been entered into the NAV 500DLX's memory. They are often saved position fixes, but can also be coordinates from a chart or map that you have entered manually.

### NOTE

With the exception of the MOB route and some Go-To routes, waypoints are required to create and navigate on a route.

The NAV 500DLX can store up to 1000 waypoints. It can also edit or rename existing waypoints and delete waypoints that are no longer needed.

**Naming a Waypoint.** A waypoint name is any unique, 6-character name (including the icon that is used to represent the waypoint on the plot display) that is assigned by you or by the unit. No two waypoints may have the same name, though since the icon is part of the waypoint name it is possible to have a waypoint named □BOAT and another named △BOAT.

To key in a waypoint name, first select the icon. The + is displayed automatically. To select a different icon, press the **RIGHT ARROW** to scroll through □, △, ▽, and +. Next, press the alphanumeric key that corresponds to the first character of the name you want to use, followed by the **RIGHT ARROW** until the desired character is displayed. Repeat until all of the characters of the name have been selected, then press **ENTER**.

**NOTE**

Use waypoint names that are easy to remember, and keep a log of waypoints that you have stored as a reference. This is especially important if you use the unit-generated waypoint names. A sample logbook page is included at the back of this manual.

To use a unit-generated name, press **ENTER** without keying in any characters. The unit will assign a numerically sequential name in the format +WPxxx, where xxx represents a number between 001 and 500. The waypoint's icon (+) can be changed by pressing the **RIGHT ARROW** before pressing **ENTER**.

**Saving a Position as a Waypoint.** A position fix can be saved as a waypoint from either the POS display or from the PLOT display.

To save the current position, press **ENTER**. Key in a name followed by **ENTER**, or press **ENTER** without making an entry to use a unit-generated name.

```

+WP001
34°06.576N
117°49.567W
0f 08/30/94
19:00:58UT GQ= 9
  
```

If a unit-generated name is used, the assigned name is displayed. Press **POS** to return to the position display.

**Manually Entering a Waypoint.** A manually entered waypoint may be a position from a chart or an old position from a waypoint log.

To manually enter a waypoint, press **WPT** to access the waypoint catalog.

```

WAYPOINT LOG
-----
+BAY  34°19.042N
      0f 117°49.576W
+BOAT 33°07.664N
      10f 117°52.321W
      ↓
  
```

Press **ENTER**. The first line is highlighted and the + icon appears. Press the **RIGHT ARROW** to select an icon, then key in a 5-character name followed by **ENTER**. You may also press **ENTER** without keying in a name (either before or after selecting another icon) to use a unit-generated name.

```

WAYPOINT LOG
+DOCK  + . . . N
+BAY  34°19.042N
      0f 117°49.576W
+BOAT 33°07.664N
      10f 117°52.321W
      ↓
  
```

Key in the latitude, then press the **RIGHT ARROW** to select N or S. (If using UTM coordinates, key in the easting.) Press **ENTER**.

```

MAYPOINT LOG
□DOCK 34°46.335N
      *      W
+BAY  34°19.042N
      0f 117°49.576W
+BOAT 33°07.664N
      10f 117°52.321W
      ↓
  
```

**NOTE**

Coordinates must be entered in the coordinate system that was selected in SETUP.

Key in the longitude, then press the **RIGHT ARROW** to select E or W. (Or key in the zone and northing.) Press **ENTER**.

```

MAYPOINT LOG
□DOCK 34°46.335N
      0f 118°19.022W
+BAY  34°19.042N
      0f 117°49.576W
+BOAT 33°07.664N
      10f 117°52.321W
      ↓
  
```

Key in the elevation, using the **RIGHT ARROW** to display a negative value if necessary, followed by **ENTER**, or press **ENTER** without making an entry to use the default elevation (the elevation of the last position fix).

```

MAYPOINT LOG
□DOCK 34°46.335N
      2f 118°19.022W
+BAY  34°19.042N
      0f 117°49.576W
+BOAT 33°07.664N
      10f 117°52.321W
      ↓
  
```

Press **ENTER** again to store the entered waypoint. Press **WPT** to key in another waypoint, any other function key to exit.



**Viewing the Waypoint Catalog.** All stored waypoints can be viewed at any time by pressing WPT, then using the DOWN ARROW to scroll through the catalog. (Waypoints are stored in alphanumeric order within each icon subgroup. Icons are listed in the order □, △, ▽, and +. Unit-generated names are listed at the end of their icon group.)

The waypoint catalog displays up to three waypoints (name and coordinates) at a time. Each time the DOWN ARROW is pressed, the display moves up by one waypoint.

If you know the name of the waypoint you want to view, press WPT then any alphanumeric key. Press the RIGHT ARROW to select the icon, then key in the remainder of the waypoint name.

Press ENTER when all or part of the waypoint name is displayed. The unit will search for and display the waypoint whose name most closely matches the entered name.

**Renaming a Waypoint.** Most waypoints can be renamed at any time. Simply display the waypoints on the first line of the waypoint catalog and press ENTER. The name is deleted; key in a new name (starting with the icon) and press ENTER.

Waypoints +strxx, and +mob cannot be renamed, but can be copied to another name. The procedure is the same. Display the waypoint with WPT, press ENTER, key in another name, and press ENTER again. The unit will create a waypoint with the new name and duplicate the coordinates to the new waypoint.

**Deleting a Waypoint.** To delete a waypoint, highlight it in the waypoint catalog, then press CLEAR, CLEAR. The waypoint will be erased from the unit's memory.

## Chapter 3

## AUXILIARY FUNCTIONS

The NAV 5000DLX has 13 auxiliary functions, which provide additional information and control over how information is displayed.

The auxiliary functions can be accessed two ways.

Press **AUX** and use the **DOWN ARROW** to scroll through the auxiliary functions until the one you want is highlighted. Press **ENTER** to access the function.

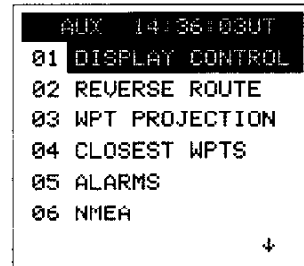

OR

Press **AUX** and the auxiliary function number you want to access. Pressing **ENTER** highlights the function you selected. Press **ENTER** again to access the function.

This chapter is arranged in numerical order; for your convenience, a table at the end of the chapter arranges the functions in alphabetical order.

### AUX 1 — DISPLAY CONTROL

The Display Control function allows you to change the brightness and contrast of the display.

Select AUX 1, then press **LIGHT** to backlight the display. Use the **DOWN ARROW** to highlight the desired feature, and the **RIGHT ARROW** to adjust the setting.

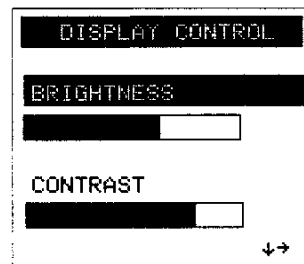

When the bar is filled, brightness/contrast is at the highest setting. Once changed, the selected values are retained until changed again or the unit's memory is cleared or lost.

### AUX 2 — REVERSE ROUTE

Reverse route allows you to reverse the order of all waypoints in any selected route (including the Go-To route). This means that you can navigate an outbound route, reverse it, and navigate back without having to manually enter a separate inbound route.

Access AUX 2. Press the **DOWN ARROW** to highlight the route to be reversed and press **ENTER**.

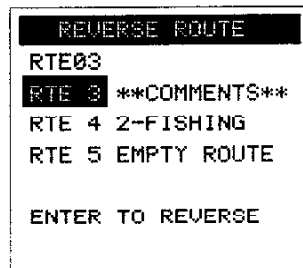

### AUX 3 — WAYPOINT PROJECTION

Waypoint projection calculates the position of a remote location, given the distance and bearing of the location from a reference position.

Access AUX 3. The unit displays POS as the reference position. To use a waypoint, press the **RIGHT ARROW** or enter all or part of the waypoint name followed by **ENTER**. Press **ENTER** when the desired position is displayed.

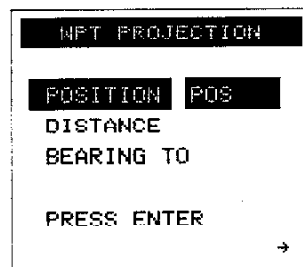

Next, enter the distance from the reference position to the remote location and press **ENTER**. Key in bearing to the remote position followed by **ENTER**. Press **ENTER** again when all entries are complete. The unit calculates and displays the coordinates of the projected waypoint.

```

WPT PROJECTION
WPT      34 *33.514N
          117 *33.142W
BEARING   013 *N
DISTANCE  30.25nm
ENTER TO NAME WPT
  
```

The projected position can be saved as a waypoint or used in a Go-To route. To save it as a waypoint, press **ENTER**. Select an icon and key in a name followed by **ENTER**, or press **ENTER** a second time without keying in a name.

To use the projected position in a Go-To route, press **GOTO**. The unit will automatically create a 1-leg route from the present position to the projected position.

#### AUX 4 — CLOSEST WAYPOINTS

This function calculates and displays the 10 waypoints that are the closest to your current position or other selected location.

Access AUX 4. The first location displayed is **POS**. To select another location, key in all or part of a waypoint name followed by **ENTER** or use the **RIGHT ARROW** to scroll through the waypoint catalog. When the desired location is displayed, press **ENTER** again.

```

CLOSEST WPTS
LOCATION POS
PRESS ENTER
  
```

The unit calculates the ten waypoints that are closest to the selected position, and lists them with the nearest waypoint first. The four closest waypoints and their range and bearing from the present position are displayed, with the nearest first. Press the **DOWN ARROW** to view the remaining waypoints.

You may set a Go-To route to any of the closest waypoints. Highlight the desired waypoint and press GOTO.

### AUX 5 — ALARMS

The NAV 5000DLX has an anchor alarm, an arrival alarm, an XTE alarm, and a proximity alarm. If AUX 5 has been turned on, each alarm causes an external beeper to sound when the vessel moves toward or away from a specific location, destination, or course by a pre-set distance.

The unit must be connected to an external beeper and to external power with the DC Power/NMEA Data Cable to use AUX 5. Although the NAV 5000DLX has an internal beeper that will sound under the same conditions that trigger the external beeper, the internal beeper is very quiet, and will not be heard if you are any distance from the unit.

#### NOTE

If the unit is unable to update the position fix for 1 minute, the external beeper will sound.

The **anchor alarm** is sounded when the vessel leaves a user-defined radius around a specific location. The location is always the current position at the time the alarm is set; the radius is entered by the user.

The **arrival alarm** is sounded when the vessel enters the arrival circle (when the unit displays the CLOSE message). The arrival circle is a 500-foot circle around the destination waypoint, and

cannot be redefined. The alarm will not sound when you pass the destination waypoint without entering the arrival circle.

The **XTE alarm** sounds when the vessel deviates a user-entered distance from the course line. It can be set to any value except "0."

The **proximity alarm** sounds when you enter a user-defined circle around a waypoint. It is usually used to mark a hazard (such as submerged rocks) and a safety zone around it. The proximity alarm is set by entering the coordinates of the hazard as a waypoint, then defining a radius around a user-selected waypoint.

**NOTE**

If the unit loses lock on a satellite while any alarm is turned on, the external beeper will be sounded.

Setting any alarm causes the unit to display an icon on the last line of all displays. The icon for the anchor alarm is ⚓; the icon for the arrival alarm is "A"; the icon for the XTE alarm is "X"; the icon for the proximity alarm is "P."

All of the alarms are reset to off when the unit is turned off.

To set the anchor alarm, highlight **ANCHOR ALARM**, **RADIUS**. Enter the distance at which you want the alarm to sound. (The unit of measure displayed is feet or meters, as selected for elevation units in **SETUP**.) Then press the **RIGHT ARROW** to turn the alarm on and off. Press **NAV**.

ALARMS	
ANCHOR ALARM	OFF
RADIUS	0 f
ARRIVAL ALARM	OFF
XTE	0 f OFF
TEST BEEPER	OFF
	↕↔

**NOTE**

We recommend entering a value that is no less than 328 feet (100 meters) when you are not receiving DGPS corrections; this will allow you to compensate for the effects of SA. If you are receiving DGPS corrections, a good minimum distance is about 98 feet (30 meters).

To turn the arrival alarm on, press **ENTER** or the **DOWN ARROW** to highlight ARRIVAL ALARM, then press the **RIGHT ARROW** to turn the alarm on and off. Press **NAV**.

The XTE alarm is set by highlighting XTE ALARM and pressing **ENTER**. Key in the distance from the course line at which the alarm will sound. Press the **RIGHT ARROW** to turn the alarm on, then press **NAV**.

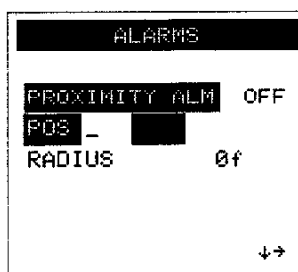

To turn the proximity alarm on, press the **DOWN ARROW** until PROXIMITY ALM is highlighted, then press **ENTER**. You may use the present position (POS) or select a waypoint by using the **RIGHT ARROW** to scroll through the waypoint catalog or by entering all or part of the waypoint name followed by **ENTER**. Press **ENTER** when the desired waypoint is displayed.

Press **ENTER** or the **DOWN ARROW** to highlight radius, then key in a value for the radius of the safe passage circle around the selected position. Press the **RIGHT ARROW** to turn the alarm on. Press **NAV**.

AUX 5 can also be used to test the external beeper. To test the beeper, press the **DOWN ARROW** until "TEST SETTING" is highlighted. Pressing the **RIGHT ARROW** should cause the

external beeper to sound. (If the beeper fails to sound, check the beeper and all connections.) Press the **RIGHT ARROW** again to turn the beeper off.

### AUX 6 — NMEA OUTPUT

If you will be supporting an NMEA device with the NAV 5000DLX, the unit's dataport must be turned on and set to an output message format that can be received by the device.

Consult your autopilot, plotter, or radar manual for instructions on how to connect to the NAV 5000DLX correctly, and to see what message format is appropriate. Also refer to *The DC Power/NMEA Data Cable* in Chapter 4.

The NAV 5000DLX supports the following NMEA messages:

- 0180
- 0183A — BWC, APA, GLL, VTG
- 0183B — RMC, RMB
- 0183C — BWC, XTE, GLL, VTG
- 0183D — APB, GGA, VTG, BWC, updated GLL  
(all 0183D messages per NMEA 0183  
ver. 2.0)

Access AUX 6, then press the **RIGHT ARROW** to select the output message format. This automatically activates the dataport.

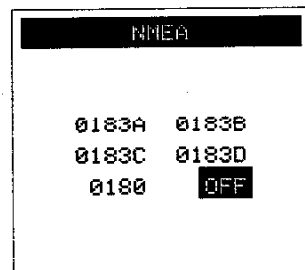

### AUX 7 — UPLOAD/DOWNLOAD

The Upload/Download feature transfers waypoints and routes between a PC and a NAV 5000DLX. This allows you to save data from the unit as a backup and to install data quickly after a memory loss.



This feature requires a PC or compatible running data transfer software that is compatible with Magellan products.

**NOTE**

Data that is uploaded from a PC to the unit will **replace** all existing waypoint and route information that is currently in the unit.

Access AUX 7, then press the **RIGHT ARROW** to select **UPLOAD-MAGELLAN** (to upload data in the Magellan format), **UPLOAD-NMEA** (to upload data in the NMEA format), or **DOWNLOAD**. Press **ENTER** to start data transfer.

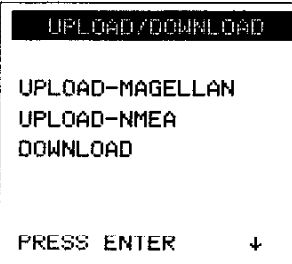

**NOTE**

To be sure that all transmitted data is received, start the receiving end first.

**AUX 8 — SETUP**

AUX 8 is used to initialize the unit before it is used for the first time or when it has been moved more than 300 miles (482.7 km) from where the last fix was taken. (Although it is possible to get a position fix without an initial position, the unit performs better when it has been initialized manually.) AUX 8 is also used to modify the unit's operating configuration.

Settings are changed by accessing AUX 8, then using the **DOWN ARROW** to scroll through the setup features and their options. (Currently selected options are highlighted.)

To change an option, press the **RIGHT ARROW**. To key in a different value (for initial position), press the alphanumeric keys.

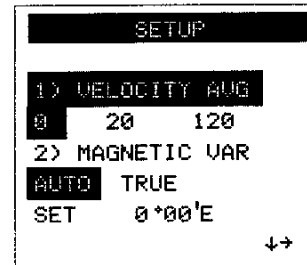
**NOTE**

When you change a feature with AUX 8, all related displays are affected. For example, once a coordinate format is chosen, that format is used for the current position, waypoints, and initial position.

**Velocity Average.** Velocity-related values (such as VMG and SOG) are based on an instantaneous measurement of speed (velocity). In practice, the instantaneous nature of the velocity measurement makes the values based on it vulnerable to momentary fluctuations. The measurements appear to vary from one moment to the next, sometimes considerably.

The velocity average feature allows you to replace the instantaneous measurement with a weighted average, taken over a selected number of seconds. This has the effect of "smoothing" and stabilizing the values displayed on the screen.

Averaging can be set to 0 seconds, 20 seconds, and 120 seconds.

To select a velocity average, use the **RIGHT ARROW** to highlight the desired setting.

**Magnetic Variation.** The heading and bearing of all displays and entries can be displayed in three ways:

Auto (M) Includes an automatic adjustment for variation by the NAV 5000DLX (default).

- True (T) Reference is True North  
Set (U) A constant user-entered adjustment is displayed.

The abbreviations M, T, and U are seen whenever bearing is displayed.

Highlight MAGNETIC VAR, then press the **RIGHT ARROW** to highlight the desired variation type. If you select SET, you must enter a variation. Key in the values, then press the **RIGHT ARROW** to toggle between E and W.

**Distance/Speed Units.** This feature selects the unit of measure that will be used to show distance and speed.

Highlight DISTANCE/SPEED UNITS, then press the **RIGHT ARROW** to select STA MI. (statue miles and mph), NM (nautical miles and knots), or KM (kilometers and kph).

**Coordinate System.** The NAV 5000DLX can display coordinates in three different systems. You may select Lat/Lon, UTM, or TD coordinates. If you select Lat/Lon, you may also select the display format; degrees/minutes or degrees/minutes/seconds.

Whichever coordinate system you choose, all coordinate entry must be in that system. The NAV 5000DLX will not accept degrees/minutes coordinates when UTM or degrees/minutes/secs has been selected.

To change the coordinate system or format, highlight COORDINATE SYSTEM. Press the **RIGHT ARROW** to highlight LAT/LON, UTM, or TD. When LAT/LON is highlighted, D/MIN and D/MIN/SEC appears. Press **ENTER**, then press the **RIGHT ARROW** to select a Lat/Lon format.

When TD is selected, press **ENTER**, then use the **RIGHT ARROW** to select the GRI of the Loran-C chain you want to use. Press **ENTER**, then use the **RIGHT ARROW** to scroll through the secondary pairs that are available for the selected GRI. Press **ENTER** when the desired pair is displayed.

**Choosing a Leg Switching Mode.** Which mode is selected here determines how the unit switches legs when navigating on a route.

With both modes, the unit constantly updates the navigation and plot screens to reference your present position to the current leg's destination waypoint. It also displays a "CLOSE" message (at the bottom of Nav2) when you are within 500 feet (152.4 meters) of the destination waypoint.

In the automatic mode, the unit switches from the current leg to the next when you cross an imaginary line that runs through the destination waypoint and is perpendicular to the course line. (Refer to the illustration below.) All navigation information is now referenced to the destination waypoint of the new leg.

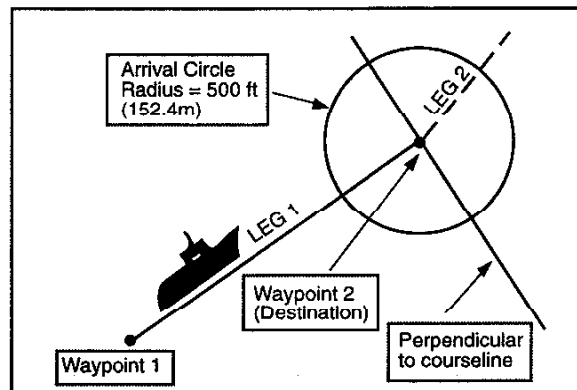

**The Route Leg**

In the manual mode, the unit does not switch legs. Instead, "ARRIVED" is displayed at the bottom of Nav2, and the unit continues to compute navigation information referenced to the destination waypoint you just passed. You must switch to the next leg manually by displaying the current route with ROUTE and using the DOWN ARROW to select the next leg. Press NAV to continue navigation.

**SETUP WORKSHEET**

SELECT ONE OPTION FOR EACH SETUP FEATURE (Factory defaults are shown in bold)

- |                             |   |
|-----------------------------|---|
| <b>VELOCITY AVERAGE</b>     | <input type="checkbox"/> <b>0 SECONDS</b><br><input type="checkbox"/> 20 SECONDS<br><input type="checkbox"/> 120 SECONDS  |
| <b>MAGNETIC VARIATION</b>   | <input type="checkbox"/> <b>AUTO (M)</b><br><input type="checkbox"/> TRUE (T)<br><input type="checkbox"/> SET (USER SET - U)<br>___° ___ E or W (Specify)   |
| <b>DISTANCE/SPEED UNITS</b> | <input type="checkbox"/> <b>STA MI. (statue mile and mph)</b><br><input type="checkbox"/> KNOTS (nautical mile and knots)<br><input type="checkbox"/> KM (kilometer and kph)  |
| <b>COORDINATES</b>          | <input type="checkbox"/> <b>LAT/LON</b><br><input type="checkbox"/> <b>D/MIN</b><br><input type="checkbox"/> D/MIN/SEC<br><input type="checkbox"/> UTM<br><input type="checkbox"/> TD<br>GRI _____<br>Secondaries _____ |
| <b>ROUTE MODE</b>           | <input type="checkbox"/> <b>AUTO</b><br><input type="checkbox"/> MANUAL   |
| <b>DGPS</b>                 | <input type="checkbox"/> <b>OFF</b> <input type="checkbox"/> ON   |
| <b>ALTITUDE UNITS</b>       | <input type="checkbox"/> METERS <input type="checkbox"/> <b>FEET</b>  |
| <b>DATE ORDER</b>           | <input type="checkbox"/> <b>M/D/Y</b><br><input type="checkbox"/> D/M/Y   |
| <b>INTERNAL BEEPER</b>      | <input type="checkbox"/> <b>OFF</b> <input type="checkbox"/> ON   |
| <b>PLOT TRACK</b>           | <input type="checkbox"/> <b>OFF</b> <input type="checkbox"/> 10 min<br><input type="checkbox"/> 1 hr <input type="checkbox"/> 2 hr<br><input type="checkbox"/> 12 hr <input type="checkbox"/> 24 hr                     |

**PLOTTER ORIENTATION**     **COG UP**     NORTH UP

**INITIAL POSITION**    Latitude \_\_\_\_\_  
Longitude \_\_\_\_\_  
Elevation \_\_\_\_\_

**MODE**     **2D**     3D     AUTO

**DATE & TIME**    Date \_\_\_\_\_  
Time \_\_\_\_\_  
 **UTC**  
 LOCAL (AM/PM)  
 LOCAL (24-Hour)

**NAV2 (A)**     **COG**     DMG     TTG  
 SOG     VGM     SOA  
 BRG     ETA     STR  
 DST     XTE

**NAV2 (B)**     COG     DMG     TTG  
 **SOG**     VGM     SOA  
 BRG     ETA     STR  
 DST     XTE

**NAV2 (C)**     COG     DMG     TTG  
 SOG     VGM     SOA  
 BRG     ETA     **STR**  
 DST     XTE

**NAV2 (D)**     COG     DMG     TTG  
 SOG     VGM     SOA  
 BRG     **ETA**     STR  
 DST     XTE

**NAV2 DISPLAY**     CDI     **VMG**

**MAP DATUM**     **WGS84**     ALASK  
 WGS72     MAUI  
 GRB36     OAHU  
 AUSTR\*     KAUAI  
 EUROP\*\*     TOKYO  
 NAD27     USER

\* Austalian Geodetic 1984    \*\* European 1950

Press the **RIGHT ARROW** to highlight the desired route mode.

**Differential Corrections.** This feature enables the NAV 5000DLX to receive broadcast differential corrections in the RTCM SC-104 format. (To use this feature, the NAV 5000DLX must be connected to a compatible DGPS receiver, such as the Magellan DBR.)

To accept differential corrections, press the **RIGHT ARROW** to highlight ON.

Once this feature is turned on, the unit displays a "D" on the status line when it is receiving differential corrections. All position fixes displayed while the "D" is visible will be differentially corrected fixes.

The unit will continue to receive and apply corrections until DGPS input is turned off or until the unit is turned off.

**Altitude Units.** Altitude units refers to the unit of measure that is used to display elevation above sea level.

Highlight ALTITUDE UNITS, then press the **RIGHT ARROW** to select FEET or METER.

The unit of measure selected here will also be used in AUX 5 for the anchor alarm radius and the proximity alarm radius.

**Date Order.** Use this feature to change the month/day order of displayed dates.

Highlight DATE ORDER, then use the **RIGHT ARROW** to select month/day/year or day/month/year.

**Internal Beeper.** The NAV 5000DLX has an internal beeper that sounds when any key on the keypad is pressed and when the SQ, GQ, and Old Data symbols are displayed.

To turn the internal beeper on, highlight INTERNAL BEEPER. Press the **RIGHT ARROW** to select YES (beeper on) or NO (beeper off).

**Plot Track.** The unit can display your actual course travelled (track) over the last 10 minutes, 1 hour, 2 hours, 12 hours, or 24 hours on the Plot display. (Plot is described in Chapter 4.) You can also select OFF.

To plot your track, highlight PLOT TRACK. Press the **RIGHT ARROW** to select how much of your track will be computed and displayed.

**Plot Orientation.** The Plot screen can display either your COG or north (true, user-set, or magnetic, as selected in SETUP) at the top of the Plot display.

To change the orientation of the Plot screen, highlight PLOTTER ORIENT, then press the **RIGHT ARROW** to highlight either COG UP or NORTH UP.

**Entering an Initial Position.** Entering an initial position is referred to as "initializing." Although the unit is able to initialize itself, entering an initial position manually will allow the unit to compute its first position fix in only a few minutes; self-initializing requires up to 15 minutes from start to finish.

The initial position must be accurate within 300 miles (482.7 km). If you are not sure what your current position is, refer to a map or chart, use the coordinates of a nearby city, or call your local marine electronics dealer.

The unit displays initial position coordinates in the format that was selected earlier in SETUP. Coordinate entry can be made only in the currently selected format.

Press the **DOWN ARROW** until INITIAL POSITION is highlighted. Press the **RIGHT ARROW** to highlight latitude (easting). Erase an existing value by pressing **CLEAR** or by entering the first number of the new position; the old position will disappear. If using Lat/Lon coordinates, use the **RIGHT ARROW** to toggle between N and S after the value for latitude has been keyed in.



**NOTE**

When entering Lat/Lon coordinates, the default hemispheres (before initialization or after memory loss) are North and West. The unit assumes that the hemispheres you choose here (or the hemispheres calculated in the last fix, whichever is more recent) are current. These hemispheres are offered as your first choice when you enter a waypoint manually.

Press **ENTER** to save the value entered and to highlight the next line. Enter the longitude (grid and northing). If entering Lat/Lon coordinates, use the **RIGHT ARROW** to toggle between E and W.

Press **ENTER** and key in your current elevation. Use the **RIGHT ARROW** to toggle between positive and negative elevations (above or below sea level). Press **ENTER**.

An accurate (within 5 meters) elevation must be entered, regardless of the mode (2D, 3D, or AUTO) you select.

**NOTE**

Failure to complete this step will cause the unit to use the default elevation of 0 feet, which may prevent the unit from obtaining the best accuracy possible.

If you are using the external antenna, enter the antenna's elevation. Antenna elevation is the sum of the elevation of your current position plus the height of the antenna installation above you.

**NOTE**

The unit can accept elevations up to 57,415 feet (17,500 meters).

**Selecting a Navigation Mode.** The NAV 5000DLX has three navigation modes. The default mode is 2D, which uses three satellites to calculate position and displays a user-entered value for elevation; 2D is used primarily at sea. The 3D mode uses four satellites to calculate position and elevation; it is used primarily on land. The Automatic mode uses 3D when at least four satellites are visible, and switches to 2D when only three satellites are visible.

Use the **DOWN ARROW** to highlight MODE, then use the **RIGHT ARROW** to highlight 2D, 3D, or AUTO.

**Date and Time Display.** The NAV 5000DLX has an almanac stored in its permanent memory, which will help the unit locate satellites to collect a current almanac and a first position fix after memory loss. In order for the unit to use the permanent almanac, you must enter the current date and time.

The GPS satellites operate on Universal Time Coordinated (UT or UTC), which is very close to the time and date that is current at the Prime Meridian.

The unit collects the current time (UT) from the GPS satellites when it collects or refreshes its almanac. It is therefore unnecessary to set the time if you want to operate in UT.

If you prefer, the unit can display local time on a 12-hour (AM/PM) clock or a 24-hour clock.

Highlight TIME, and use the **RIGHT ARROW** to highlight UT or LOC.

If LOCAL is selected, you must enter the local clock time. Key in the time, then press **ENTER**. Press the **RIGHT ARROW** to select 24 or AM/PM.

**Nav2 Variables.** The Nav2 display has four user-selected variables, which may be selected with Nav2(A), Nav2(B), Nav2(C), and Nav2(D). The defaults and locations are as shown below.

COG <A>	SOG <B>
STR <C>	ETA <D>

Press the **DOWN ARROW** to highlight the position whose variable you want to change. Press the **RIGHT ARROW** to select SOG, COG, BRG, DIS, DMG, VMG, ETA, XTE, TTG, SOA, or STR.

**Nav2 Display.** Either a CDI or a VMG bar can be shown on the NAV2 display. Default is the VMG bar.

The CDI is described in *Navigation*.

The VMG bar is a hollow horizontal bar that fills from left to right to display your current VMG in relation to your current SOG as a percentage. (This is rounded to the nearest 10% for display.)

Press the **DOWN ARROW** to highlight NAV2 DISPLAY, then press the **RIGHT ARROW** to select the VMG bar or CDI.

**Map Datums.** The NAV 5000DLX provides 11 geodetic map datums for use with charts and maps worldwide. The unit also allows you to enter manually any map datum into the unit's memory.

You must operate the NAV 5000DLX on a datum that corresponds to the charts you are using in order to take advantage of GPS's accuracy. Which datum your chart uses can usually be found in the legend.

Highlight MAP DATUM, then press the **RIGHT ARROW** to select the desired datum.

OFF: the unit has been instructed to ignore this satellite by the user, perhaps because its SQ is very low. The satellite remains off until the user turns it back on.

Satellites that are listed in the almanac as being unhealthy by the GPS system operators are not shown in Sat Status. Satellites are identified by a pseudorange number (PRN), which is used by the government to identify the satellites.

Access AUX 9. The unit displays POS and the current date and time. You may use POS or select a waypoint by pressing the **RIGHT ARROW** or keying in all or part of a waypoint name followed by **ENTER**. Press **ENTER** when the desired position is displayed.

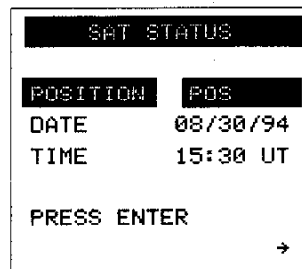

You may use the current date and time or enter another date and time (up to six months in the future) to project Sat Status into the future. Press the **DOWN ARROW** to highlight DATE and key in a new date followed by **ENTER**. Press the **DOWN ARROW** again to highlight TIME; key in a new time followed by **ENTER**.

Press **ENTER** again when all entries are complete. The unit computes and displays graphically the satellites that are visible to the selected position on the date and time entered.

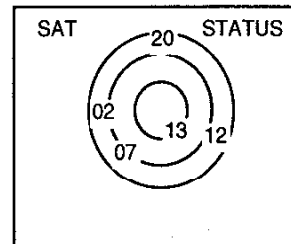

Each PRN represents a satellite, with the location of the PRN approximating the elevation and azimuth of the satellite. Satellites with higher elevations are closer to the center of the concentric circles. The position of the PRN along the concentric circles represents the satellite's azimuth; north is the top of the display.

To view the status of the rest of the satellite constellation, press **ENTER**. The operating status (ON, OFF, or TOFF) of the satellites is on the left side of the column marked "STATUS."

The right side displays the acquisition status of the satellites that are visible to the selected position. This column will contain data only if the current time and date were used and the unit has been operated in the last two hours.

SAT STATUS		
SAT	EL	AZ STATUS
02	71	*088 *M ON *9T
03		
06	30	*178 *M ON *8T
11		
12		

↕→

The acquisition status is:

- \* is or will be used for a position fix
- S unit is searching for this satellite
- L unit is locked onto this satellite's signal
- E unit has collected ephemeris data for this satellite
- T unit is locked onto the signal and has obtained ephemeris data

The information displayed with Sat Status is current for the place, date, and time entered only. The display does not update to reflect changing conditions.

### **AUX 10 — SKY SEARCH /ALMANAC COLLECT**

Sky Search is a random search for satellites from all channels that is conducted automatically when the unit's almanac is 6 months old or has been erased. It is initiated manually with AUX 10 whenever you want to collect a new almanac.

In Sky Search, the unit follows a prescribed search hierarchy on all five channels to search the sky for satellites. When a satellite is located the unit collects an almanac from it. At the same time, the unit continues to search for other satellites on the remaining four channels in order to obtain a position fix. (If you do not have an initial position when you enter Sky Search, the unit calculates one and self-initializes.)

Sky Search is not initiated immediately when AUX 10 is accessed.



Press **ENTER** again to activate Sky Search. The unit deletes the existing almanac (if any) and displays the receiver activity screen while it searches for and acquires satellites. Once the first satellite is acquired, the unit collects an almanac from it and displays "ALM CLLCT"

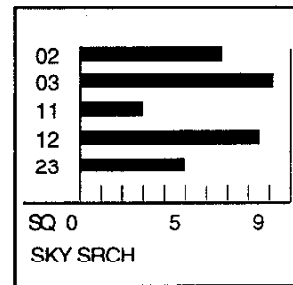

at the bottom of the screen. The unit continues to search for satellites on the remaining four channels while the almanac is being collected.

A position fix is computed and displayed as soon as three satellites have been located and acquired. (If the unit has no initial position this fix will be used as the initial position.) This usually occurs before Almanac Collect is finished. "ALM CLLCT" will remain on the screen until a complete almanac has been collected.

Once Almanac Collect is finished (about 12-1/2 minutes), the unit verifies the almanac data; the unit will display "ALM VERIFY" at the bottom of the display.

Do **not** turn the unit off during Almanac Collect or Almanac Verify; doing so will prevent the unit from collecting a complete almanac, and will cause the unit to collect another almanac when it is turned on again. This will delay your time to first fix.

#### AUX 11 — BATTERY SAVER

The Battery Saver allows you to conserve power by controlling how long the unit operates (2-minute periods or continuously) when operating from battery power.

When the Battery Saver is on, the unit obtains position fixes for 2 minutes and turns itself off. This drains relatively little power from the batteries. (The unit will **not** turn itself off during Sky Search, Almanac Collect, or Almanac Verify.)

#### NOTE

The unit does not adequately support most NMEA devices when the Battery Saver is on. If you want to support an NMEA device, we recommend that you turn the Battery Saver off or operate from external power.

When the Battery Saver is off, the unit operates until it is turned off with the ON/OFF key or until two minutes after the second battery warning appears. Battery Saver OFF is the default setting.

Operating the unit with the Battery Saver off is a heavy drain on the batteries. If you plan on operating for any length of time with the Battery Saver off, consider using external power instead.

Once set, Battery Saver remains unchanged until reset with AUX 11 or until the unit's memory is lost or cleared.

Access AUX 11. Press the **RIGHT ARROW** to toggle between ON and OFF.



### AUX 12 — ERASE WAYPOINTS

This feature is used to delete either the current track from the Plot display or **all** of the waypoints and routes in the unit's memory.

Access AUX 12. Press the **RIGHT ARROW** to select TRACK or ROUTE AND WPTS. When the desired category is highlighted, press **CLEAR**.

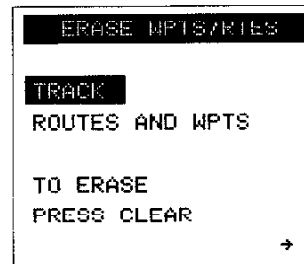

The unit provides an opportunity to abort the procedure. To continue clearing the selected category, press **CLEAR** again. To abort, press any other function key.

### AUX 13 — ERASE MEMORY

Erase Memory erases all or selected portions of the unit's memory. Before using this function be very sure that this is what you really want to do.

#### NOTE

Clear Memory can be accessed only by pressing AUX 13. It does not appear if you scroll through the Auxiliary Functions with the DOWN ARROW.



You may select:

ALL – to erase **everything** in the unit's memory

USER DATUM – to erase a user-entered datum

FACTORY DEFAULT – erases all non-default setup parameters that were entered with AUX 8; the unit will return to factory-set defaults

ALMANAC/EPHEMEROUS – to erase the almanac and ephemeris data the unit may have collected recently

INITIAL POSITION – to erase the initial position.



Access AUX 13. Use the **DOWN ARROW** to highlight the area you want to delete. Press **CLEAR**; the unit displays "PRESS CLEAR AGAIN" Press any key (other than **CLEAR**) to abort. Press **CLEAR** to erase everything in the highlighted area.

The last line of the screen displays CLEARED when the highlighted option has been erased. Select another area and press **CLEAR** again, or exit AUX 13 by turning the unit off.

The unit must be turned off after using AUX 13.

The following table is an alphabetical list and brief description of the Auxiliary Functions. It is not intended to replace the descriptions earlier in this chapters, but only to provide a quick reference.

<b>Auxiliary</b>	<b>Code (AUX +)</b>	<b>Page</b>	<b>Description/Function</b>
Alarms	5	3-4	Turns on an external anchor alarm, an arrival alarm, a proximity alarm, and an XTE alarm. Also tests external beeper.
Battery Saver	11	3-23	Turns the Battery Saver on and off.
Closest Waypoints	4	3-3	Computes and displays the 10 waypoints that are closest to your present position.
Display Control	1	3-1	Controls the brightness and contrast of the unit's display.
Erase Memory	13	3-24	Deletes all or selected areas of the unit's memory.
Erase WPT/Routes	12	3-24	Deletes all waypoints/routes or track.
NMEA Output	6	3-7	Selects the output message format for supported NMEA devices and turns on dataports.
Reverse Route	2	3-2	Reverses the order of all waypoints in the selected route.



*Magellan NAV 5000DLX*

*Auxiliary Functions*

Sat Status	9	3-19	Computes the azimuth and elevation of satellites for the location, date, and time entered; also displays satellite status.
Setup	8	3-8	Initializes the unit; displays and changes operating parameters including display language selection.
Sky Search/ Almanac Collect	10	3-21	Searches for satellites in a prescribed hierarchy to collect an almanac and determine position after a total memory loss. Also accessed with POS after memory loss.
Upload/ Download	7	3-7	Transfers waypoints and route information between the NAV 5000DLX and a personal computer. Requires Magellan software.
Waypoint Projection	3	3-2	Estimates the latitude and longitude of a distant position, based on the estimated distance and bearing from POS or a selected waypoint.

This chapter describes how to replace batteries, connect the NAV 5000DLX to external power and equipment, and how to solve the operating problems you may encounter.

### BATTERIES

The NAV 5000DLX uses six AA alkaline batteries as an operating power source and to maintain memory between operating sessions. (We recommend Eveready Energizer™ batteries.)

Batteries are never recharged while in the unit.

The unit operates continuously until it is turned off or until the batteries (or the battery pack) no longer has sufficient power to operate the unit. Battery life can be extended by turning the Battery Saver on with AUX 11.

#### NOTE

The unit does not adequately support most NMEA devices when the Battery Saver is on. Turn the Battery Saver off or use external power to support NMEA devices.

**Alkaline Batteries.** Alkaline batteries provide up to 10 hours of continuous use. The drop off at the end of their lives is gradual enough to allow the unit to display two power warnings: an initial warning that battery power is low, and a second warning that there is insufficient power remaining to continue operation (the batteries will still have enough power to maintain the unit's memory for up to one month).

The first warning is an icon (🔋) that appears on all displays; you should still have about 30 minutes of operating time remaining when the battery icon appears.

The second warning is a full-screen display (REPLACE BATTs OR LOSE DATA) that is shown for two minutes, after which the unit turns itself off. When the second warning appears, the batteries have enough power to maintain memory for up to 4 months, but not to operate the unit. Fresh batteries must be installed to ensure that the unit's memory will be protected. Until the batteries are replaced, the unit can be operated only from external power.

The NAV 5000DLX is shipped with alkaline batteries already installed.

**The Rechargeable Battery Pack.** The NAV 5000DLX can also be powered from the Magellan Rechargeable Battery Pack. The battery pack contains high-capacity nickel cadmium batteries, which are compatible with the power requirements of Magellan products. The Rechargeable Battery Pack can be used with all 5000-series Magellan hand-held receivers.

The battery pack can power the unit for up to 5 hours of continuous use, after which the power drop can be quite sudden. (The same battery warnings are displayed when the battery pack is at low power, but because of the sudden power drop, you may notice only the second warning.) When using the battery pack for long operating sessions, we suggest that replacement batteries, a fully charged battery pack, or external power be available.

The Rechargeable Battery Pack and a variety of charging adapters are available as options from your Magellan dealer. The battery pack cannot be recharged in the unit.

**Loading the Batteries.** Use the procedure below to install alkaline batteries or the battery pack in the unit.

1. Turn the unit off. If the unit was being operated from external power, also disconnect the NAV 5000DLX from the external power source.

**NOTE**

Always be sure the unit is off when connecting or disconnecting external power. Failure to observe this precaution may result in lost memory or a frozen display.

2. Holding the unit as shown in the illustration, pull the battery cover firmly toward the bottom of the unit until it stops, then lift the door off. To create a seal against moisture, the cover fits snugly and will not move easily.

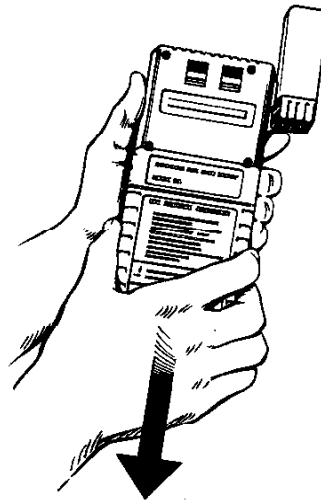

**Opening the Battery Cover**

3. Remove the battery clip or battery pack. Insert fresh batteries in the clip, being careful to align the batteries as shown on the clip.
4. Insert the fresh clip or a fully charged battery pack into the battery compartment so the external contacts are on the right.

**NOTE**

The unit can maintain its memory without batteries for as long as 15 minutes. To reduce the risk of memory loss, batteries should be changed as quickly as possible.

5. Remove any dirt, sand, or other foreign matter from the battery compartment seal.
6. Replace the battery cover. Position the cover over the battery clip and push up firmly until the door settles into place. Be sure the door is secure.

**EXTERNAL POWER OPERATION**

Operating power for the NAV 5000DLX can also be provided by an AC wall outlet, ship's power, or a car's battery. How external power is provided is determined by your other power needs and available connections, and whether connections are also be made to other navigation equipment or a PC.

All connections to the unit are made via the 5-pin power/data port opposite the unit's antenna. Only Magellan equipment should be used to connect the unit to any external power source. All Magellan adapters and interfaces have been designed to supply to correct level of DC voltage; the use of any other equipment or altered Magellan equipment may harm the unit and will void the warranty.

**NOTE**

Always be sure the unit is off when connecting or disconnecting external power. Failure to observe this precaution may result in lost memory or a frozen display.

As part of the power-on sequence, the unit looks for an external power source. If external power is detected (and is at acceptable levels), the unit will bypass the batteries. (The batteries are still

required to maintain memory between operating sessions.) Batteries will not be recharged during operation from external power.

If external power is lost or falls below acceptable levels during operation, the unit will display "EXTERNAL POWER LOST" for two minutes then turns itself off. To continue operating on battery power, press any function key before power-off.

**NOTE**

Whichever method you choose to provide external power to your NAV 5000DLX, remember to turn the unit off before connecting or disconnecting external power, and to use only Magellan equipment to make connections to external power supplies.

**The DC Power/NMEA Data Cable.** The DC Power/NMEA Data Cable is used to connect the NAV 5000DLX to a DC power source such as ship's power, to an NMEA device, to a DBR, and/or to an external alarm. Any or all connections can be made at the same time with one cable as shown in the illustration below. Please note that the single back wire must be connected to the ground of both the NMEA device and the power source.

The NMEA device being supported must receive data in the 0180 or 0183 formats. The differential radio beacon receiver must relay data at 4800 baud when an NMEA 0183 or no device is supported, or at 1200 baud when an NMEA 0180 device is supported.

**The PC Interface Cable.** The PC Interface Cable has connections for the unit, any Magellan power adapter, and a PC's 9-pin serial port. It is required if you plan to transfer data between the unit and a PC.



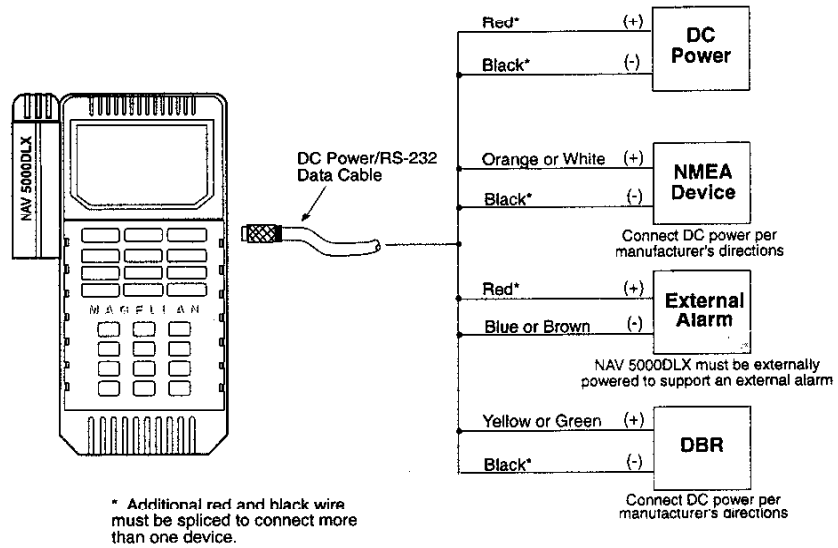

Connecting the DC Power/NMEA Data Cable

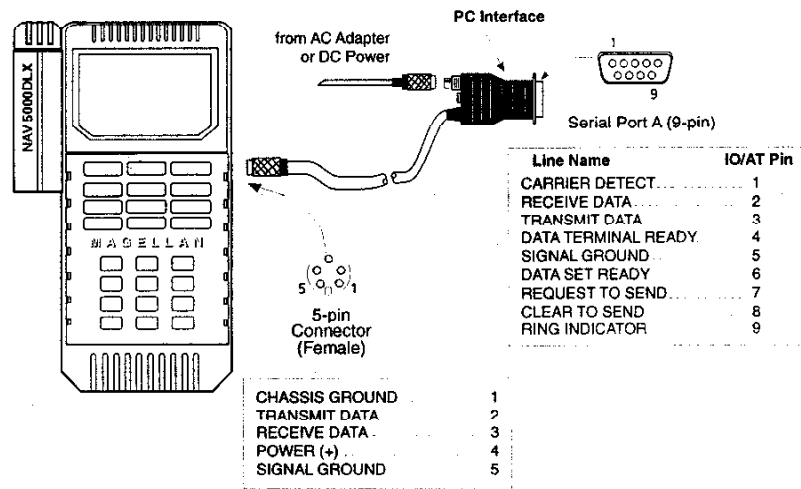

Connecting the PC Interface Cable

**Power Adapters.** The NAV 5000DLX can be operated from an AC power supply such as a home or office wall outlet or a car battery. This requires the use of the appropriate Magellan AC adapter or the Cigarette Lighter Adapter.

Before purchasing an adapter, discuss your requirements with your Magellan dealer to select the correct adapter for your application.

### ERROR AND WARNING MESSAGES

Error and warning messages are displayed to alert you to a condition you need to be aware of. Most messages require a response or action on your part. A few are informative only.

MESSAGE	DESCRIPTION/SOLUTION
	<p><b>First battery warning:</b> The 6 AA-batteries (or the battery pack) are getting low. Typically, the unit can be operated for 30 minutes (Battery Saver off) or 15 sets of fixes (Battery Saver on) without jeopardizing the unit's memory.</p> <p><b>Do this:</b> <i>Replace the batteries. The unit can maintain its memory without batteries for as long as 15 minutes.</i></p>
	<p><b>Old data:</b> The unit has lost contact with one or more of the satellites used for the previous fix and cannot find another available satellite. The position fix displayed with this symbol is at least 10 seconds old, and should not be used to navigate.</p> <p><b>Try this:</b></p> <ol style="list-style-type: none"> <li><i>1. Press POS, POS to check receiver activity. Also check Sat Status (AUX 9) to be sure all visible satellites are set to ON.</i></li> <li><i>2. Reposition the antenna to see if you can get a clearer view of the sky.</i></li> <li><i>3. If using 3D or AUTO, try 2D.</i></li> </ol>

-  **GQ warning:** The Geometric Quality of the position fix is 3 or less; the fix is not accurate, and should not be used to navigate. This symbol appears on all screens of the affected position fix.

- Try this:**
1. **Check Sat Status (AUX 9) to be sure all satellites are ON.**
  2. **Check the angle of elevation and azimuth of the visible satellites: are signals being blocked by your surroundings? Try changing your position or the location of the antenna and taking another fix.**
  3. **If using 3D or AUTO, try 2D.**

-  **SQ warning:** The Signal Quality of one or more satellites is 3 or less. This indicates that the signal is not strong and the unit may lose it. SQ has little effect on accuracy, and is displayed for information only. This symbol appears on all screens of the affected position fix.

- Try this:** **Change your position or the position of the antenna. Even a slight change may be enough to allow the receiver to get a stronger signal.**

#### NOT ENOUGH SATELLITES

**Not enough satellites are visible to take a position fix:** If operating in 2D, there are fewer than three satellites; if operating in 3D, there are fewer than four satellites.

- Try this:**
1. **Make sure the antenna has a clear view of the sky.**
  2. **If using an exterior antenna, check the connections.**
  3. **Verify the initial position and time (see SETUP).**

**4. Check Sat Status (AUX 9) to be sure all satellites are set to ON.**

**5. If in 3D, try using 2D or switch to AUTO. In AUTO the unit takes 3D fixes when four satellites are available and 2D fixes when only three satellites are available.**

**6. If none of the above works, or if the unit has not been used for more than a few minutes in the past six months, press AUX 10 to initiate Sky Search and collect a new almanac.**

#### EXTERNAL POWER LOST

**External power has been lost or the level of external power supplied to the unit is below minimum requirements:** The unit is therefore operating on battery power.

- Do this:**
- 1. Check the cable and/or adapter to be sure it is secure. Be sure to turn the unit off before securing loose connections.**
  - 2. Check the external power source for malfunctions.**
  - 3. Press any function key except ON/OFF or LIGHT to continue.**

#### REPLACE BATTS OR LOSE DATA

**Second battery warning:** You ignored the first battery warning, and battery power is now dangerously low. The unit turns itself off two minutes after this message appears, even if the Battery Saver is off. Until fresh batteries are installed, the unit can be operated only from external power. Once this message appears, the batteries have enough residual power to protect memory for up to four weeks.

- Do this:** **Turn the unit off immediately and insert new batteries.**

## OPERATING PROBLEMS

Use the table below to identify problems that arise when operating the unit.

CONDITION	DESCRIPTION/SOLUTION
FROZEN DISPLAY:	The display is frozen and the keypad does not respond.
<b>Do this:</b>	<b>Remove the batteries and wait for the unit to turn off.</b>
NO POWER:	
Battery operation	The batteries are inserted into the clip incorrectly.
<b>Do this:</b>	<b>Insert the batteries into the clip correctly.</b>
	The battery compartment is not clean or dry.
<b>Do this:</b>	<b>Make sure the battery compartment is clean and dry.</b>
	The batteries have run down completely; memory is lost.
<b>Do this:</b>	<b>Replace the batteries. Initialize the unit manually, then collect a current almanac with AUX 10; or allow the unit to self-initialize.</b>
External power	The power jack or cable connectors are loose or not fully inserted
<b>Do this:</b>	<b>Make sure the connections are secure and fully inserted. The connections should be snug; if necessary, replace the adapter.</b>

**Do this:**

Power adapter connections loose.

**Make sure the connector is securely connected. The connection should be snug; if necessary, replace the adapter.**

DC Power/NMEA Data Cable has not been connected to a DC power supply.

**Do this:**

**Connect the unterminated wires of the DC Power/NMEA Data Cable to a DC power source, as shown earlier in this chapter.**

UNIT TURNS OFF  
DURING USE

The unit is operating with the Battery Saver on.

**Do this:**

**Turn unit back on. Use AUX 11 to turn the Battery Saver off.**

External power was interrupted, and the unit switched to battery power.

**Do this:**

**Turn the unit on. Watch the self-test display to verify the power source. Check the external power source for malfunctions. Also check all connections.**

POSITION FIX  
DOESN'T CHANGE

The signal from one or more satellites has been lost; the position fix displayed is the most recent one available, and the hourglass is visible on the fourth line of the display.

**Do this:**

**Refer to §. in "Error and Warning Messages."**

Display may be frozen; keypad does not respond.

**Do this:**

**Remove the batteries and wait for the unit to turn off.**

THE "D" DOES NOT  
APPEAR ON POSITION  
FIX SCREENS

The "D" is displayed only when the unit is receiving differential corrections and producing corrected fixes. It does not appear when the fix is old.

**Do this:**

- 1. Check SETUP (AUX 8) to be sure the DGPS function is on.**
- 2. Check all connections.**
- 3. The differential radio beacon receiver must relay corrections at 4800 baud when an NMEA 0183 or no NMEA device is being supported, and at 1200 when an NMEA 0180 device is supported.**
- 4. Check to be sure that the differential radio beacon receiver is locked onto a DGPS beacon, receiving and demodulating data, and relaying data. Refer to the user guide for your differential radio beacon receiver.**

The satellite set being used by the unit includes one or more satellites the U.S. Coast Guard beacon is not currently tracking. The unit is

**Do this:**

therefore not receiving corrected information on all of the satellites being used for the position solution.

- 1. Use AUX 9 (Sat Status) to determine where in the sky the satellites being used are, and which satellites are furthest away from the beacon. Turn off the satellites that are the most distant and try again.**

FIXES VARY  
A LOT

The position accuracy of the NAV 5000DLX is affected by several variables, the most important of which is the geometric quality of the fix. Therefore, the specified accuracy of 15 meters RMS in 2D is statistical, not absolute, and assumes the absence of selective availability.

Since 20 meters is approximately 0.01 minute of latitude (and 0.01 minute of longitude at the equator), it is possible to see variations as large as  $\pm 0.03$  minutes of latitude/longitude from fix to fix when conditions are good.

You can increase position fix accuracy by using differential.

If the unit is being operated near the poles, small changes in position may cause great variations in position and velocity-related data.

NMEA DEVICE IS NOT  
RESPONDING

The dataport is not turned on.



**Do this:**

**Use AUX 6 to turn the dataport on.**

The unit is not sending output messages in correct format.

**Do this:**

**Refer to the device's user guide to determine the correct message format.**

Cables and adapters are not secure or are not connected correctly.

**Do this:**

**Check all cables and adapters; refer to the illustrations in this chapter for proper connections.**

The unit is not in continuous operation.

**Do this:**

**Turn the unit off, connect the unit to an external power source, and turn the unit back on; or turn the Battery Saver off (AUX 11).**

AUTOPILOT DOES NOT RESPOND

Refer to "NMEA Devices," above.

You are not navigating on a route.

**Do this:**

**Activate a route as described in Chapter 2. Operate from external power or with the Battery Saver off.**

NAV DOES NOT WORK

You must be travelling faster than 0.2 knots to get velocity-related data, such as speed over ground (SOG), course over ground (COG), steering, speed of advance (SOA) or time to go (TTG).



**Try this:** **Increase speed to 0.2 knots or greater.**

Navigation- and velocity-related data is not available until three fixes have been made.

**Do this:** **Wait until three position fixes have been taken, then try again.**

Only SOG and COG are displayed when a route is not active.

**Do this:** **Activate a route.**

DASHES APPEAR IN NAV DISPLAYS

You are 65.6 feet (20 meters) or less from your destination. Bearing is no longer available. This is normal.

OR

Your speed is too slow to provide velocity-related data such as speed, ground course, and steering. You must be travelling at least 0.2 knots to obtain this data.

**Do this:** **Increase your speed to at least 0.2 knots.**

SOME VALUES IN NAV DISPLAYS ARE NOT STABLE

Certain values are calculated from an instantaneous measurement of speed. Since speed may fluctuate from one instant to another, these calculations may seem unsteady. The navigation calculations that may be affected are VMG, SOA COG, TTG, and ETA; the velocity calculation that may be affected is SOG.

**Do this:**

**Use Velocity Average to replace the instantaneous measurement with a weighted average. Select an average of fixes over 20 seconds or 120 seconds. See AUX 8 — SETUP.**

SATELLITE  
AVAILABILITY NOT  
TO YOUR  
EXPECTATIONS

The position or health of a satellite may have been changed by the government. You may also have last collected an almanac on a day when one or more satellites were set to "unhealthy."

**Do this:**

**Check your initialized position, time, and the satellites listed in Sat Status (AUX 9). Collect a new almanac with Sky Search, then check Sat Status again. Note if more satellites are listed now.**

You may have turned some satellites off, perhaps because they had low SQs or low elevations and you wanted the unit to ignore them.

**Do this:**

**Check Sat Status with AUX 9. Scroll through the satellites. If any are set to OFF, reset them to ON.**

You are using 3D, which requires four satellites. Until the GPS constellation is complete, satellite coverage in some areas and at some times of day may not be sufficient to support 3D operation to your complete satisfaction.

**Try this:**

**Try operating in 2D or AUTO.**

### OPERATING TIPS

---

**General.** Most equipment malfunctions can be prevented by observing the following guidelines:

- Turn the unit off before connecting or disconnecting external power
- Do not leave the unit face up in the sun
- Do not operate the unit in temperatures above 60°C or below -10°
- Do not store the unit at temperatures above 70°C or below -40°C
- If the unit is dropped in the water, carefully rinse both the outside of the unit and the battery compartment with fresh water, then dry thoroughly

**Unsure of Your position When Initializing.** You have several options if you do not know the coordinates for your current position when initializing the NAV 5000DLX.

You can determine your position from a map or chart, using basic navigation techniques. You can also use the coordinates of some nearby landmark or city; any position that is within 300 miles (482.7 km) of your true position is accurate enough to allow the unit to identify which satellites should be visible to your location.

If you know your approximate distance and bearing from a known location (such as an easily identified landmark on a map), you can use Waypoint Projection to project coordinates for your present position. This should be accurate enough to allow the unit to obtain a first position fix fairly quickly.

You can also allow the unit to self-initialize. When the unit is turned on and has no initial position or almanac, it automatically starts Sky Search. (Sky Search is described in Chapter 4.) This is normally interrupted by the initial position and time/date you

enter during initialization, which allows the unit to refer to its permanent almanac to determine satellite availability. If uninterrupted, self-initialization requires about 15 minutes to collect and verify an almanac and to compute a position fix using the first three satellites acquired. Since the unit has no initial position, the first fix obtained is saved as the initial position.

**Initialization Errors.** An initialization error occurs when the initial position you entered is 300 miles (482.7 km) or more from your true position. It may also occur when the unit has been moved 300 miles or more since its last position fix.

The unit searches for satellites based on where it thinks it is; it compares its initial position or last fix (whichever is more recent) to the almanac, and determines which satellites are likely to be visible to its location. If the initial position/last fix is 300 miles or more away from the unit's true position, the unit searches for satellites that are not visible, which greatly increases the length of time required to locate satellites and compute a position fix.

When the computed fix is far from the initial position/last fix, that the unit assumes that an initialization error has occurred and self-initializes using the satellites that have already been acquired. This takes between 10 and 60 seconds.

Sometimes, the initialization error is so large that the unit is unable to locate enough satellites for a position fix. When this occurs, the unit will continually search the sky for satellites. (You will notice the PRN numbers on the receiver activity change periodically.) If the unit does not have a new position fix after about 20 minutes, either re-initialize or use AUX 10 to start Sky Search. Also check the receiver activity screen to be sure the antenna is receiving enough satellite signals to compute a fix.

**The Signal Environment.** The signal environment is the physical conditions in which the unit is being operated that may affect the unit's ability to locate and track satellite signals.

Poor environments include areas that obstruct or hinder the antenna's view of satellites. The effects of poor signal environ-

ments can be lessened by operating the unit with its antenna in a near vertical position, giving the antenna as clear a view of the sky as possible, and not putting the antenna too close to possible obstructions.

If the unit is unable to locate satellites, either because of an initialization error or because of a poor signal environment, it will search continually until a satellite is found. If the unit does not have a position fix after about 20 minutes, re-initialize and/or move the antenna to a better location. Check the receiver activity screen and the Satellite Status screen, and refer to *Orienting the Antenna* in Chapter 1 to position the antenna correctly.

### CHOOSING A DATUM

A MAP datum is a mathematical description of the earth or a part of the earth that is necessary to correctly assign real-world coordinates to points on a map or chart. Since each datum is based on different assumptions and measurements, a position calculated in one datum can differ by 600 meters or more from the same position calculated in another datum. To take advantage of the inherent accuracy of GPS, it is necessary to reference the datum used by the NAV 500DLX to the datum used by your maps and charts.

There are hundreds of datums, but only a few are in widespread use today. The NAV 500DLX uses the WGS84 datum as its default; this is a world-wide datum that is also used by the GPS system. Which datum is used by your charts can be found in the map legend (look for "horizontal datum") and in the user guides for your electronic navigation equipment.

If your maps or equipment uses a different datum, be sure to set the NAV 500DLX to use the same datum. The NAV 500DLX has 11 datums in its memory. If the datum you need is not pre-defined, select "USER" and key in the constants for the desired datum as described in *SETUP, Map Datums*. The constants can be found in *Appendix 3*.

The National Oceanic and Atmospheric Administration (NOAA) is currently changing its charts to NAD83; for most purposes, this is the same as WGS84. Most NOAA charts in use now are NAD27 or NAD83. USGS (U.S. Geological Survey) maps are usually in NAD27.

### STORING THE UNIT

---

Use the instructions below to prepare the NAV 5000DLX for storage.

**For More Than 3 Months.** To prepare the unit for long-term storage:

- Manually record all waypoints, or use data transfer software to transfer your waypoint catalog to a PC
- Record any non-default parameters from SETUP
- Remove the battery clip or battery pack from the unit
- Place the unit in the carrying/storage case or in its original box

When the unit is taken out of storage, reload the battery clip with fresh batteries, then re-initialize and re-configure SETUP. Enter or transfer the waypoints you recorded before removing the batteries.

**For Less Than 3 Months.** To prepare the unit for short-term storage:

- Load fresh batteries into the unit to save any stored waypoints, almanac, and non-default SETUP settings
- Place the unit in the carrying/storage case or in its original box
- If storing the unit in the carrying/storage case, place the field card in the front pocket to be sure no keys are accidentally pressed

### **WHEN NOTHING ELSE WORKS**

---

When nothing described in *Operating Problems* solves your problem, you can try clearing the unit's memory by pressing AUX 13. This is a last-ditch solution, since all of the unit's memory will be cleared. Be sure to record your waypoints and any non-default SETUP setting before doing this.

In extreme cases, such as when the display is frozen and the keypad will not respond, remove the battery clip for at least 1/2 hour. This will also erase the memory.

### **MAGELLAN'S CUSTOMER SUPPORT**

---

Customer Service representatives are available Monday through Friday, between 8 AM and 5 PM, Pacific Standard Time at 909-394-5000. Faxes can be sent at any hour to 909-394-7050.

If necessary, you can also return your unit to Magellan for repair. (Please call Customer Service for assistance first.) If possible, please notify us before shipping the unit by Parcel Post or UPS. Include with the unit a description of the problems and your name and address. If your return shipping address is different, please include it.

#### **Packages should be sent to:**

Magellan Systems Corporation  
960 Overland Court  
San Dimas, CA 91773  
Attention: Warranty Repair



## Free Manuals Download Website

<http://myh66.com>

<http://usermanuals.us>

<http://www.somanuals.com>

<http://www.4manuals.cc>

<http://www.manual-lib.com>

<http://www.404manual.com>

<http://www.luxmanual.com>

<http://aubethermostatmanual.com>

Golf course search by state

<http://golfingnear.com>

Email search by domain

<http://emailbydomain.com>

Auto manuals search

<http://auto.somanuals.com>

TV manuals search

<http://tv.somanuals.com>