



PCIe Expansion System User's Manual



ExpressBox²
PCI Express® to PCI Express® Expansion

Model: EB2
Model: EB2R

Copyright © 2008 Mission Technology Group, Inc. - DBA Magma

This publication is protected by Federal Copyright Law, with all rights reserved. No part of this publication may be copied, photocopied, reproduced, stored in a retrieval system, translated, transmitted or transcribed, in any form or by any means manual, electric, electronic, electro-magnetic, mechanical, optical or otherwise, in whole or in part without prior written consent from Magma.

Limitation of Liability

Information presented by Magma in this guide is believed to be accurate and reliable. However, Magma assumes no responsibility for its use. No license is granted by implication or otherwise to any rights of Magma.

Product specifications and prices are subject to change without notice.

Trademark References

Trademarks and registered trademarks are proprietary to their respective manufacturers.

Table of Contents

PREFACE	III
Advisories	iii
Safety Instructions.....	iv
When Working Inside a Computer	iv
Protecting Against Electrostatic Discharge	v
Rack-Mount Instructions	vi
CHAPTER 1 INTRODUCTION	1
General Specifications	1
Pre-Installation Information	2
Parts List	2
Tools Required for Installation.....	2
CHAPTER 2 HARDWARE INSTALLATION	3
Before you Begin.....	4
Install PCI Express Host Card.....	4
Attach Power and Expansion Cables	6
Laptop Installation (optional).....	7
Recheck the Installation	10
Applying Power Correctly	11
Starting Up:.....	11
Software Installation (Optional, for ExpressCard):.....	12
Shutting Down:.....	15
Rack Installations (for the EB2R model)	15
Add Screws to Rack Post	15
Attach Slide Rail to Rack	16
Attach Chassis to Slide Rail.....	17
CHAPTER 3 VERIFY INSTALLATION	18
Windows	18
Mac OS X.....	19
Expansion Slot Utility	19
Apple System Profiler.....	20
RedHat 9 Linux	22
CHAPTER 4 INSTALL CARDS AND DRIVES	24
Remove PCIe Expansion Chassis Cover	24
Install 3 rd Party PCIe Cards.....	25
Installing Double-Wide PCIe Video Cards	27
Install Hard Drive(s)	28
System Should Be Up and Running.....	30
Finishing Touches	30
“Hot-Swappable” PCIe Card Installations.....	31
Procedure for hot-un-plugging a PCIe plug in card:	32
PCIe Expansion Solutions with the EB2.....	35
Digi Design Pro Tools®	35

M A G M A

Video Card expansion solutions..... 36
High Throughput storage solutions 38

CHAPTER 5 TROUBLESHOOTING..... 40

Locate the Problem 40
My Computer Can't Find the PCIe Expansion System 41
When Nothing Works 43
 My Computer Hangs During Power Up..... 44
My PCIe Card Doesn't Work..... 45
 Support for 3rd Party PCIe Cards 47
 Windows Error Codes 47
The System Fans Don't Appear To Spin Fast Enough 49

CHAPTER 6 HOW TO GET MORE HELP..... 51

Frequently Asked Questions (FAQ)..... 51
Contacting Technical Support 51
 Magma Debug Utility 52
 PCIScope Software Utility 53
Returning Merchandise to MAGMA..... 55

APPENDIX A NEED MORE PCIE SLOTS? 56

Multiple PCIe Expansion System Configurations 56
 Fan-Out 58
 Verify your configuration 59
 Daisy-Chaining 60
 Verify your configuration 60
 Combination Configurations..... 61
PCI e Card Conflicts..... 62
Power-On Sequence for Advanced Configurations 62
Troubleshooting Advanced Configurations..... 62
 Finding the Problem Card 64

APPENDIX B COMPLIANCE 65

FCC 65
Industry Canada 65
CE 65

Preface

Advisories

Five types of advisories are used throughout this manual to provide helpful information, or to alert you to the potential for hardware damage or personal injury. They are **Note**, **Important**, **Caution**, **Warning**, and **Danger**. The following is an example of each type of advisory.



NOTE

Used to amplify or explain a comment related to procedural steps or text.



IMPORTANT

Used to indicate an important piece of information or special "tip" to help you



CAUTION

Used to indicate and prevent the following procedure or step from causing damage to the equipment.



WARNING

Used to indicate and prevent the following step from causing injury.



DANGER or STOP

Used to indicate and prevent the following step from causing serious injury or significant data loss.

Disclaimer: We have attempted to identify most situations that may pose a danger, warning, or caution condition in this manual. However, Magma. does not claim to have covered all situations that might require the use of a Caution, Warning, or Danger indicator.

Safety Instructions

Always use caution when servicing any electrical component. Before handling the Magma PCI-Express Expansion chassis, read the following instructions and safety guidelines to prevent damage to the product and to ensure your own personal safety. Refer to the "[Advisories](#)" section for advisory conventions used in this manual, including the distinction between Danger, Warning, Caution, Important, and Note.

- ◆ Always use caution when handling/operating the computer. Only qualified, experienced, authorized electronics personnel should access the interior of the computer. The power supplies produce high voltages and energy hazards, which can cause bodily harm.
- ◆ Use extreme caution when installing or removing components. Refer to the [installation instructions](#) in this manual for precautions and procedures. If you have any questions, please contact Magma Technical Support.



WARNING

High voltages are present inside the expansion chassis when the unit's power cord is plugged into an electrical outlet. Disconnect the power cord from its source before removing the system cover.

Never modify or remove the radio frequency interference shielding from your workstation or expansion unit. To do so may cause your installation to produce emissions that could interfere with other electronic equipment in the area of your system.

When Working Inside a Computer

Before taking covers off a computer, perform the following steps:

1. Turn off the computer and any peripheral devices.
2. Disconnect the computer and peripherals from their power sources to prevent electric shock or system board damage.
3. Disconnect any telephone or telecommunications lines from the computer.

In addition, take note of these safety guidelines when appropriate:

- ◆ To help avoid possible damage to systems boards, wait five seconds after turning off the computer before removing a component, removing a system board, or disconnecting a peripheral device from the computer.
- ◆ When you disconnect a cable, pull on its connector or on its strain-relief loop, not on the cable itself. Some cables have a connector with locking tabs. If you are disconnecting this type of cable, press in on the locking tabs before disconnecting the cable. As you pull connectors apart, keep them evenly aligned to avoid bending any connector pins. Also, before connecting a cable, make sure both connectors are correctly oriented and aligned.

**CAUTION**

Do not attempt to service the system yourself except as explained in this manual. Follow installation instructions closely.

Protecting Against Electrostatic Discharge

**Electrostatic Discharge (ESD) Warning**

Electrostatic Discharge (ESD) is the enemy of semiconductor devices. You should always take precautions to eliminate any electrostatic charge from your body and clothing before touching any semiconductor device or card by using an electrostatic wrist strap and/or rubber mat.

Static electricity can harm system boards. Perform service at an ESD workstation and follow proper ESD procedures to reduce the risk of damage to components. Magma strongly encourages you to follow proper ESD procedures, which can include wrist straps and smocks, when servicing equipment.

You can also take the following steps to prevent damage from electrostatic discharge (ESD):

- ◆ When unpacking a static-sensitive component from its shipping carton, do not remove the component's anti-static packaging material until you are ready to install the component in a computer. Just before unwrapping the anti-static packaging, be sure you are at an ESD workstation or are grounded.
 - ◆ When transporting a sensitive component, first place it in an anti-static container or packaging.
-

M A G M A

- ◆ Handle all sensitive components at an ESD workstation. If possible, use anti-static floor pads and workbench pads.
- ◆ Handle components and boards with care. Don't touch the components or contacts on a board. Hold a board by its edges or by its metal mounting bracket.

Rack-Mount Instructions

Elevated Operating Ambient - If installed in a closed or multi-unit rack assembly, the operating ambient temperature of the rack environment may be greater than room ambient. Therefore, consideration should be given to installing the equipment compatible with the maximum ambient temperature (T_{ma}) Specified by the manufacturer.

Reduced Air Flow - Installation of the equipment in a rack should be such that the amount of air flow required for safe operation of the equipment is not compromised.

Mechanical Loading - Mounting of the equipment in the rack should be such that a hazardous condition is not achieved due to uneven mechanical loading.

Circuit Overloading - Consideration should be given to the connection of the equipment to the supply circuit and the effect that overloading of the circuits might have on overcurrent protection and supply wiring. Appropriate consideration of equipment nameplate ratings should be used when addressing this concern.

Reliable Earthing - Reliable earthing of rack-mounted equipment should be maintained. Particular attention should be given to supply connections other than direct connections to the branch circuit (e.g. use of power strips).

Chapter 1 Introduction

General Specifications

The Magma 2 Slot PCI Express® to PCI Express® Expansion System is a general-purpose bus expansion chassis for the Peripheral Component Interconnect Express (PCIe) local bus. The expansion chassis is fully compliant with the PCI Express Local Bus Specification. This system consists of a PCI Express host card, a 3-meter iPass cable, the 2-slot PCIe expansion chassis and a set of rack-mount brackets.

Item	Description
▪ Host Card:	Low Profile PCI Express x8 host card
▪ Backplane:	2 PCIe slots (expandable to 4 or more by chaining chases)
▪ Enclosure:	1U Rack-mount
▪ Dimensions:	14.26" W x 1.735" H x 16.41" D
▪ Weight:	5.2lbs or 2.40 kg
▪ Standard Cable Length:	3-meter iPass cable
▪ PCI Express Bus Specification	Revision 1.1
▪ PCI Local Bus Specification:	Revision 2.3
▪ PCI Bridge Architecture Spec:	Revision 1.2
▪ Interconnect Bandwidth:	4000 MB/sec or 4 GByte/sec
▪ Cooling:	Three 20mmx40mm, 12VDC, 6 CFM fans
▪ Power Supply:	200W auto-switching power supply
▪ MTBF:	53,000 hours
▪ Operating Environment:	0° to 50° C Operating Temperature -20° to 60° C Storage Temperature 5% to 85% Relative Humidity, Non-condensing
▪ Operating Systems:	Windows XP/2000/Server 2003/Vista Mac OS X version 10.4.x + Red Hat Linux 9
▪ Warranty:	1 Year Return to Factory
▪ Available Options:	Hi Speed, 13.2 CFM Fan (PN:01-05052-01)

Pre-Installation Information

Before using the Magma expansion chassis you should perform the following steps:

- Inventory the shipping carton contents for all of the required parts
- Gather all of the necessary tools required for installation
- Read this manual

Parts List

The following parts are provided in the EB2 model. The EB2R model includes a rack installation kit as well.

Item	Qty	Item
①	1	EB2 Magma expansion chassis
②	1	3-meter shielded iPass™ cable
③	1	Low profile PCI Express x8 host card
④	1	U.S. Standard 115V power cord
	1	Quick Start Guide



Tools Required for Installation



In order to complete the installation of the Magma expansion system you may need a Phillips-head screwdriver, depending on the installation type.

Chapter 2 Hardware Installation

The following steps will guide you through the installation of your Magma expansion system.

Electrostatic Discharge (ESD) Warning



All PCI cards are susceptible to electrostatic discharge. When moving PCI cards, it is best to carry the cards in anti-static packaging. If you need to set a PCIe card down, be sure to place it inside or on top of an anti-static surface. For more information, see "[Protecting Against Electrostatic Discharge](#)" in the Preface.

WARNING



High voltages are present inside the expansion chassis when the unit's power cord is plugged into an electrical outlet. Disconnect the power cord from its source before removing the enclosure cover. Turning the system power off at the power on/off switch does not remove power to components. High voltage is still present.

CAUTION



Before touching anything inside the enclosure, move to an ESD station and follow proper ESD procedures. Failure to do so may result in electrostatic discharge, damaging the computer or its components. For more information, see "[Protecting Against Electrostatic Discharge](#)" in the Preface.

STOP



If your Magma expansion chassis was not purchased directly from Magma, you must check to ensure that it doesn't contain any pre-installed PCIe cards.

Check the rear side of the chassis to see if any PCIe cards are visible in the slots. If you see a PCIe card, you should continue installation using instructions provided by your dealer. If no separate instructions are available, remove the cover by using instructions in [Chapter 4 Install Cards and Drives](#). Then remove the card(s) as normal. If no PCIe card is visible, then continue with the cable installation.

Before you Begin

The system's ATX power supply is auto-switching. This means that it will automatically switch to match whatever source power you are using. Since all products ship with a US/Canadian Standard 125V power cord, you will need to use a locally available power cord for non-US Standard power sources.

1 Install PCI Express Host Card

Begin the installation of your PCI Express (PCIe) host card by first powering down your computer. Use the procedures for shutting down your operating system and shutting off power to your system provided in your owner's manual or system documentation.

The PCIe host card is a "half-height," x8-capable PCIe card mounted to a "full-height" bracket as shown below:



For low profile case applications, you may need to change the mounting bracket to the low profile bracket that shipped with your system. This is done by removing the screws that hold the card to the bracket. Be sure you are using proper ESD procedures when completing this action.

Once the host computer is off and all power cords disconnected, remove the cover and insert the PCI Express host card into a vacant x8 (or x16) PCIe slot by gently pushing the card until it is firmly seated. Then secure the card to the slot with a mounting screw.

Notice that the PCI Express slots are located at a greater distance from the edge of the computer's mother-board than are the standard PCI slots as illustrated in the following figure.

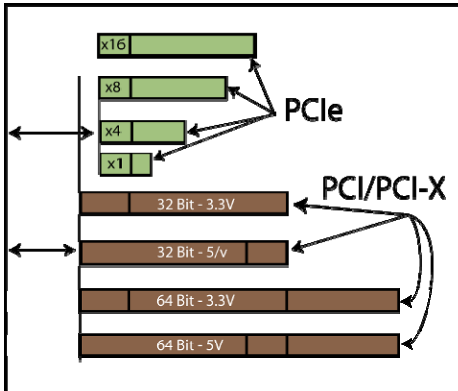
**STOP**

YOU MUST ONLY INSTALL THE PCIe HOST CARD INTO A **PCI EXPRESS SLOT**.



Only use cards WITH brackets. This will ensure that your PCIe host card can only be inserted into a PCIe slot. Although PCI Express cards without brackets may fit into conventional PCI slots, you run the risk of damaging the PCI Express host card if you insert it into a PCI slot. Please ensure that your host computer has PCI Express slots and install the host card **only** into a PCI Express slot.

For more information on using PCIe cards, please refer to your computer's user manual or system documentation.

Note that a physical x16 slot (in length) can electrically be connected as x4 or less. Therefore it is important to consult your motherboard's user manual to verify the actual bandwidth supported by the slot.

M A G M A

Next check the DIP switch settings on the Magma Host Card as shown:

The DIP switch can be set to either the x4 or x8 position as can be seen in the photo.

Since EB2 supports x8 speeds, it is recommended to set it in the x8 position for optimized performance and compatibility. It should only be set to x4 if one is certain that the PCIe slot on the host PC is x4.

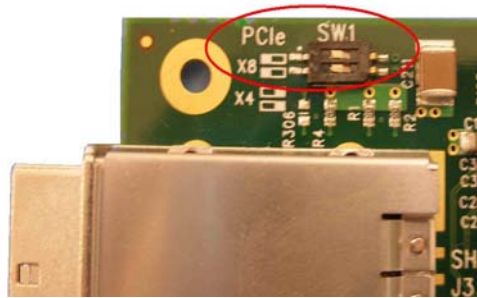

2 Attach Power and Expansion Cables

Carefully position the expansion chassis so that the supplied expansion cable will conveniently reach from the host computer to the connectors on the back of the chassis. Connect one end of the iPass cable to the expansion chassis' iPass connector labeled "IN". Then connect the other end of the iPass cable to the host card located in the host computer. Finally connect the power cord to the back of the chassis.

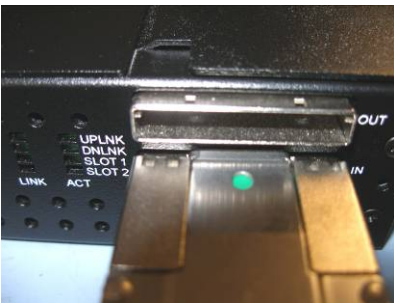

Connect one end of the cable to the bottom iPass connector



Connect the other end of the cable to the host card.

**CAUTION**

All cables attached to the expansion chassis must be securely fastened. When you hear a “click,” it is properly secured. If not securely connected, the connectors may cause intermittent or lost connections.

**NOTE**

If at all possible, plug all power cords from the expansion chassis and your host computer into a shared power strip, preferably one that has surge and noise suppression circuitry built into it.

Laptop Installation (optional)

In addition to interfacing the EB2 expansion system to a PC, you can now add additional PCI Express slots to your laptop by installing Magma’s ExpressCard host and connecting it to your chassis with a dedicated iPass-to-TDP cable featuring an iPass interface on one side and a TDP interface on the other.

Attach one end of the PCI Express cable to the Magma ExpressCard module and the other end to the connector on the back of the Magma chassis.

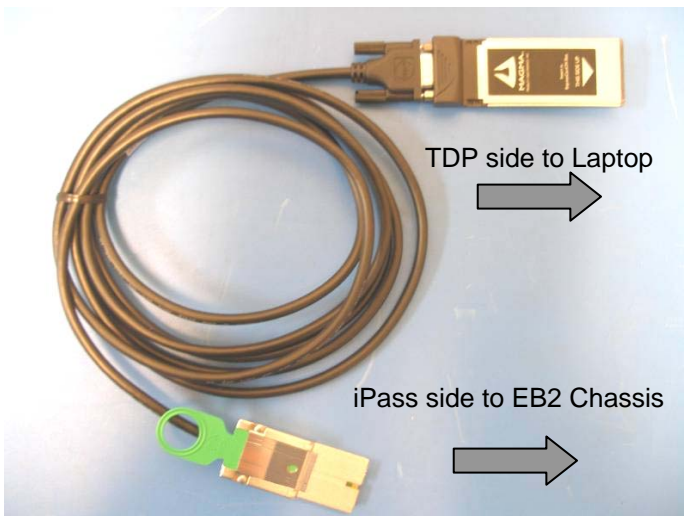

M A G M A

Tighten the thumbscrews connecting the ExpressCard to the cable on one end and verify the other end is properly latched into the iPass connector of the chassis.

In spite of the standardized design of the TDP interface, it is not impossible to connect the male and female connectors upside-down. In order to avoid that, please note the proper and improper concavity orientation of the connectors as shown in the two cases below:

Picture A shows the correct orientation:

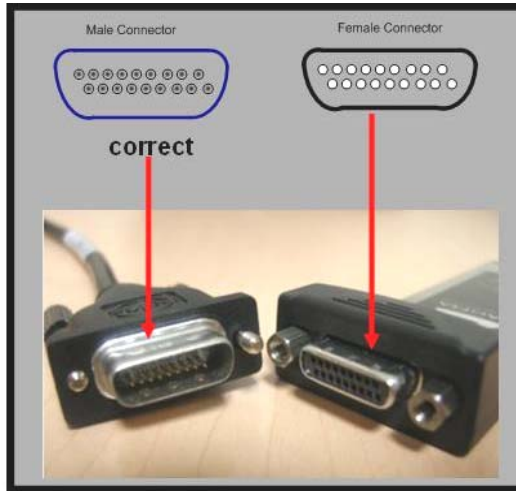

PICTURE A

Picture B shows the Incorrect orientation:

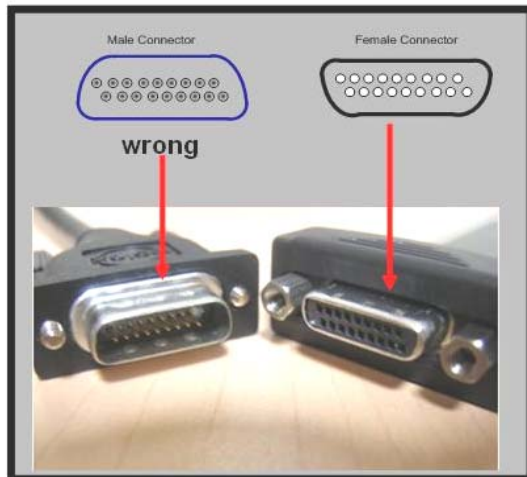

PICTURE B

Before inserting the Magma ExpressCard, power down your laptop computer. Use the procedures for shutting down and powering off your system provided in your owner's manual or system documentation.

Insert the Magma ExpressCard module with the logo side up, into the ExpressCard slot on your computer. Gently push the card until it is firmly seated.

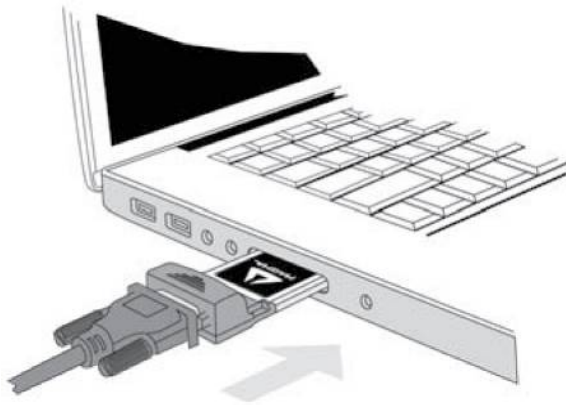
**NOTE**

The Magma ExpressCard module can only be used in a computer system that contains an ExpressCard slot. It will not function in CardBus or PCMCIA slots.

**NOTE**

If your laptop's ExpressCard slot is "spring-loaded", be sure that your ExpressCard is inserted correctly. It is very easy for this style slot to partially release a card if touched slightly.

For more information on using ExpressCard modules, please refer to your computer's user manual or system documentation.

**IMPORTANT**

Due to an incompatibility issue between the chipsets used in the expansion system and those used by nVidia in its line of PCIe video cards, nVidia video cards will not function in the EB2 chassis if it is connected through the ExpressCard interface to the host PC. There is no issue interfacing with nVidia cards plugged into the EB2 chassis via the PCIe host card interface.

3

Recheck the Installation

Check your installation **before** powering up the Magma expansion chassis for the first time. Although the power supply has an over voltage protection device built into it, it may not "trip" in time to fully protect a device that has been improperly connected, or whose power cable has been damaged.



CAUTION

This product is provided with a power supply that automatically adjusts to input voltages between 100 to 240 Vac. A U.S. and Canadian 125 V power supply cord is provided with this product. If using this product outside of the U.S. or Canada, please use locally available power supply cords

4 Applying Power Correctly

Starting Up:

It is recommended that you apply power to the Magma expansion chassis prior to powering up your computer. This will allow the PCIe bus hierarchy to be in a stable state when the host system issues its master power-on bus reset. This will also allow the software driver to recognize the PCI bus hierarchy and any attached devices.

The system's On/Off switch is located on the front panel, as well as an LED indicator to indicate power status. Verify that the green power indicator is ON after pressing the button.



Windows Start Up

As your Windows computer starts up, you will see a small message box pop-up in the lower-right corner of the screen to alert you that Windows has found new hardware.



The system does not require any Magma drivers in order to operate properly with the [x8 PCIe Host card](#). However, it may require a driver in order to work with the optional [ExpressCard host](#), hence we added the next section.

You may now proceed to [Chapter 3 Verify Installation](#).

MAC Start Up

Apple MAC OS computers will boot up without any visible indicators that the Expansion System is connected. Go to: [Chapter 3 Verify Installation](#).

RedHat 9 Linux Start Up

Similarly, RedHat9 OS computers will boot up without any visible indicators that the Expansion System is connected. Proceed to: [Chapter 3 Verify Installation](#).

Software Installation (Optional, for ExpressCard):

A driver is NOT required for Windows Vista, but may be required for a Windows XP installation. You should first install your 3rd Party card and connect the system as described in [Chapter 2](#). Only if you are having problems accessing the expansion system under Windows XP should you install the Magma ExpressCard drivers.

Before attempting to install anything on a Windows XP system, you should ensure that you have set a new Restore Point. See your Windows XP manual to learn how to set a new Restore Point. You should ensure that all data files are closed and that you have a current backup.

STOP

Before installing drivers, you should ensure that you have a current system backup of all of your important data.



Failure to follow these instructions exactly could result in a system lock-up and potential loss of data.

Be alert

Be careful

Be protected

You must also disable your anti-virus software before continuing.

For best success when installing the Magma driver:

- Have a current system backup or restore point
- Reboot and Shut down each time you are prompted
- Be logged in as 'System Administrator'
- Follow the installation instructions provided in this guide-

Install Driver

- 1 Download driver from Magma website at <http://www.magma.com/support/drivers/index.html>
- 2 Click on the Open button to create a C:\ExpressBox folder on your computer.

- 3 Click on the Winzip button to unpack the files into the C:\ExpressBox folder.
- 4 Click on the OK button to confirm the files are unpacked.
- 5 Click on the Close button to close WinZip.
- 6 Go to the C:\ExpressBox folder and double-click on the Setup.exe file to start the driver installation.
- 7 Follow instructions on the screen during the installation.
- 8 Reboot your computer.

The setup program will prepare the necessary files and present the following window to start the driver installation.

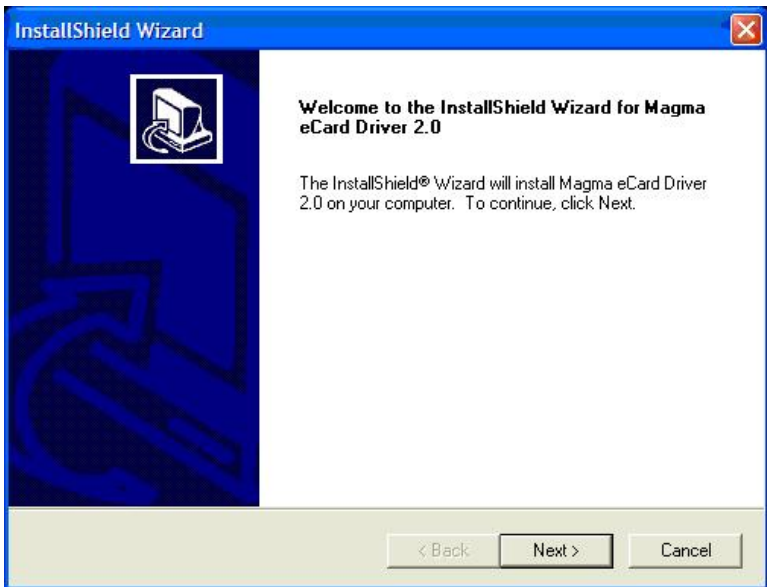

Click **Next** to continue and review the licensing agreement.

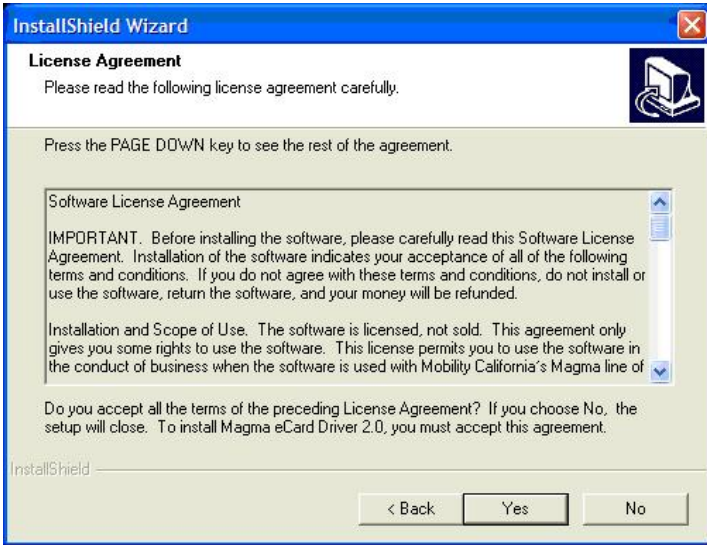

Review the licensing agreement. If you agree, click **Yes** to continue. If you do not agree, click **No** to exit.



Rather than restarting your computer, it is recommended that you click **“No, I will restart my computer later.”**, and then click **Finish**. You will be instructed to SHUT DOWN your computer in the next step.

Shutting Down:



STOP

DO NOT TURN OFF THE MAGMA EXPANSION CHASSIS UNTIL YOU HAVE SHUT DOWN YOUR COMPUTER COMPLETELY! It can cause a system lockup and loss of any unsaved data.

When shutting your system down, it is recommended that you first shut down the computer correctly, and then power down the Magma expansion chassis to avoid 'computer lock-up' and potential data loss.

Rack Installations (for the EB2R model)

Locate a vacant 1U slot in your rack that is within the reach of the iPass data cable provided with your EB2 Expansion System. Install the rails in the rack as shown below:

Measure the rack from front to back so you can confirm how long the rail must be to fit properly.

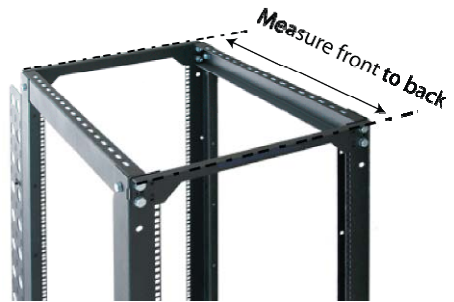

Next, assemble the Slide piece with the end bracket as shown and secure with 2 Panhead screws and locking nut. Ensure the Phillips screw head is located on the "open" side of the Slide pieces as shown.

Tighten finger tight only to allow for minor adjustment during assembly.

Depending on the depth of your rack you may select either the long or the short end bracket.



Add Screws to Rack Post

Attach 2 Panhead screws into the rack post where you want the chassis mounted. Be sure you have measured accurately to ensure that everything fits in the rack correctly. Leave the screws untightened until after you place the slide rail's fingers between the screws as shown.

M A G M A

If your rack has holes too large for the screws, you can use the Bar Nut to secure your mounting by inserting the Panhead screw through the rack hole and screwing it into the Bar Nut on the reverse side of the rack post, as shown:

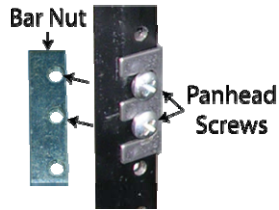

NOTE

Notice that the holes on the Bar Nut are spaced unevenly to accommodate different racks.

The EB2 chassis requires two extender brackets (supplied with the rack-mounting kit) be installed on one side of the chassis in order for the chassis to fit widthwise in a standard rack.

The extender brackets should be attached in-between the Bar Nut and the Panhead screws as shown:

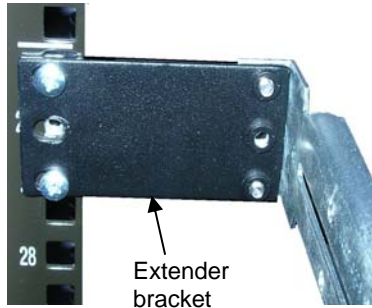

Attach Slide Rail to Rack

Attach the other side of the rack with "fingers" pointing "out" and the end bracket to the rear. Secure each Slide Mount with 4 screws as shown below.

Secure the slide rail to the rack with 2 screws to both front and rear posts. After you have secured the slide rail fingers to the rack posts, tighten the 2 screws used to attach the slide rail to the end bracket.

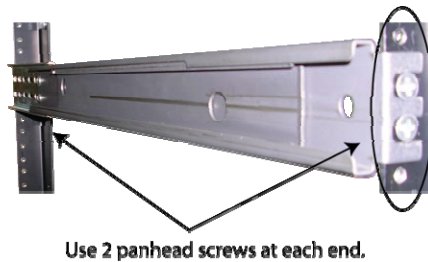

Attach Chassis to Slide Rail

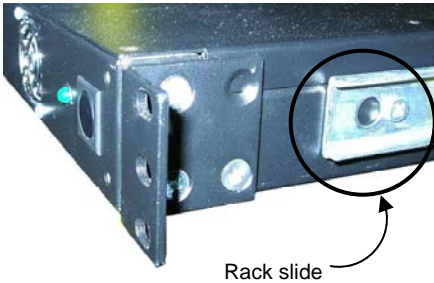

The chassis mounts into the rack from the rear. Before you can attempt to insert the chassis's rack slide into the half of the rack slide you just mounted to the rack, you must first fold the hinged mounting brackets to a forward position as shown.

Next, insert the chassis into the rack slide and press it forward until the chassis stops.

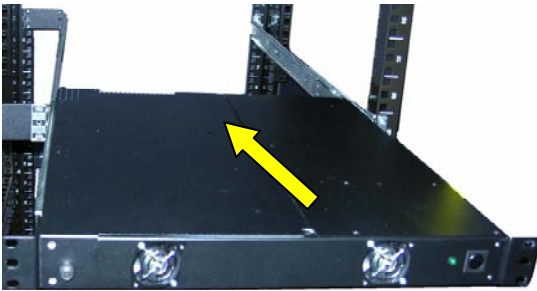

When the chassis is completely inserted into the rack, secure the hinged mounting brackets with 2 screws on each side.

CHAPTER 3 Verify Installation

Windows

To verify a successful installation on Windows, find the **'My Computer'** icon and "right-click" on it. Then select **'Manage'** from the pop-up menu. Next, click on **'Device Manager'** in the leftmost Computer Management window. Finally, click on the **View Menu** and select **View Devices by Connection**.

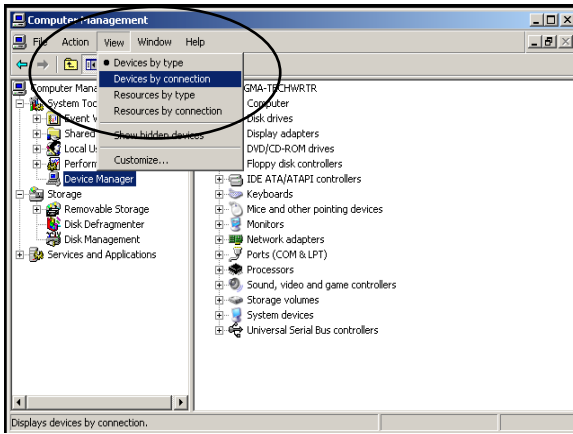

Open ACPI (BIOS) → Open PCI Bus → Click the '+' sign several times until your reach a PCI Express Root Port with a PCI Standard PCI-to-PCI Bridge beneath it.

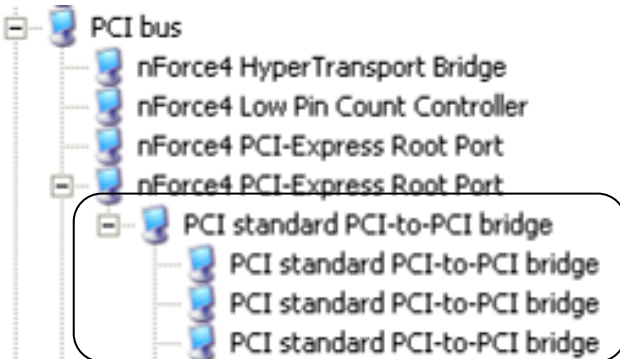

When installed properly, you will see four PCI Bridges (ports) below your system's PCIe Root port: One x8 uplink and three x8 downlink.

If the verification is successful, you may now proceed to [Chapter 4](#) and install 3rd Party PCIe Cards as well as auxiliary peripherals, such as hard drives into the chassis.

If, however, the installation was unsuccessful, you may not see the PCI to PCI Bridge, or it will have a small yellow  in front of it as shown below:

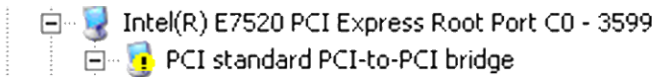

In that case proceed to [Chapter 5](#) for Troubleshooting installation problems.

Mac OS X

When using Mac OS X no additional software or drivers are needed. The operating system should automatically recognize the Magma host card and expansion chassis.

Expansion Slot Utility

The following screen may be displayed the first time you turn on your computer with the Magma EB2 installed.

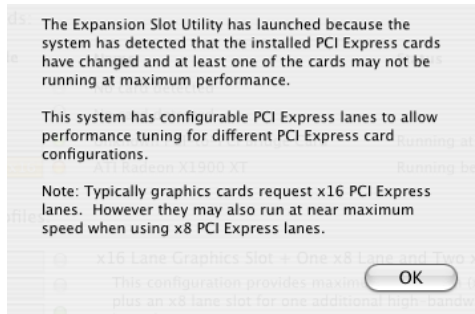

Choose OK.

MacOS X is prompting you to choose a PCI Express profile that maximizes the performance of your attached devices. **The Magma host card can communicate up to a bandwidth of x8 to and from the expansion chassis and devices.** You should choose a profile that matches the configuration of all the cards installed in your Mac. Magma recommends that you install the system host card into a x8 slot in order to maximize throughput.

M A G M A

In this example, the Magma host card is installed in slot 4 and appears as “Intel PCI-to-PCI Bridge Card”.

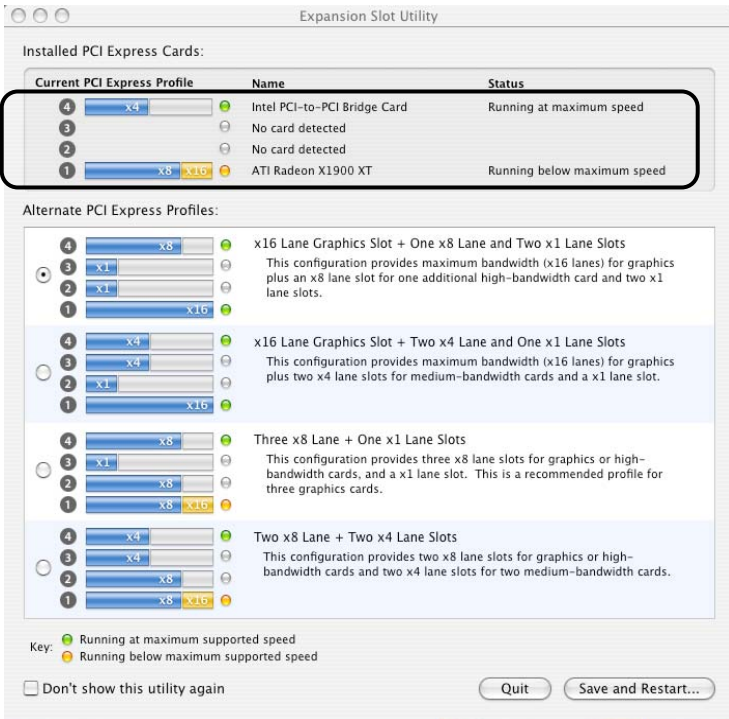

If your computer did not automatically prompt you to choose a PCI Express profile, you can locate this utility under System → Library → CoreServices → Expansion Slot Utility.app.

Apple System Profiler

When using Mac OS X no additional software or drivers are needed. As long as you are using Mac OS X Version 10.4 or newer, the operating system should automatically recognize the Magma expansion chassis.

Select “About This Mac” under the Apple Icon

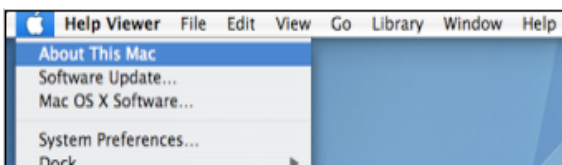

Then click the “More Info” button → click on the Devices tab → you should see a **pci-bridge** device listed under PCI as shown below:

Any PCIe Cards you install in the expansion chassis will appear behind the **pci-bridge** device.

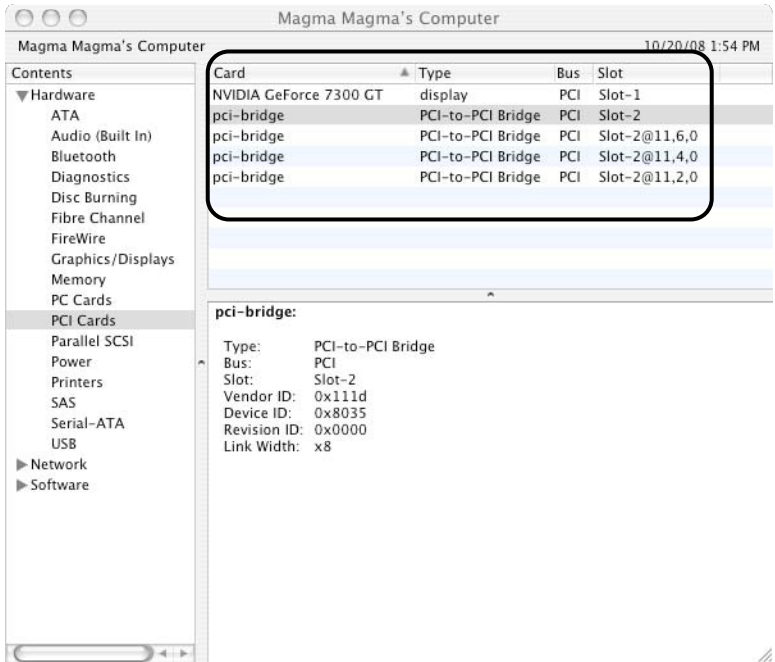

Mac OS 10.5.x

If any of these devices are not displayed as shown above, you should shut down your system (computer first, then the expansion chassis) and reconnect the cables and the PCIe expansion host card to ensure that you have a solid connection. Then restart the Magma expansion chassis followed by the computer. Next, try to verify the installation again, as shown above. If you are still having problems, contact Magma Technical Support at (858) 530-2511.

RedHat 9 Linux

Once the EB2 has been installed in a RedHat9-based system, its installation can be verified by typing the following command lines:

lspci -t Displays the overall structure of the PCIe expansion system

lspci -vv Lists additional information about the PCIe switch (in our case it will list the Integrated Device Technology (IDT) information.

lspci -vvv Displays the most comprehensive information about the expansion system.

Below we've shown the output corresponding to the **lspci** command:

```
00:00.0 Host bridge: Intel Corporation 82945G/GZ/P/PL Memory Controller Hub (rev 02)

00:01.0 PCI bridge: Intel Corporation 82945G/GZ/P/PL PCI Express Root Port (rev 02)

00:1b.0 Audio device: Intel Corporation 82801G (ICH7 Family) High Definition Audio Controller (rev 01)

00:1c.0 PCI bridge: Intel Corporation 82801G (ICH7 Family) PCI Express Port 1 (rev 01)

00:1c.2 PCI bridge: Intel Corporation 82801G (ICH7 Family) PCI Express Port 3 (rev 01)

00:1d.0 USB Controller: Intel Corporation 82801G (ICH7 Family) USB UHCI #1 (rev 01)

00:1d.1 USB Controller: Intel Corporation 82801G (ICH7 Family) USB UHCI #2 (rev 01)

00:1d.2 USB Controller: Intel Corporation 82801G (ICH7 Family) USB UHCI #3 (rev 01)

00:1d.3 USB Controller: Intel Corporation 82801G (ICH7 Family) USB UHCI #4 (rev 01)

00:1d.7 USB Controller: Intel Corporation 82801G (ICH7 Family) USB2 EHCI Controller (rev 01)

00:1e.0 PCI bridge: Intel Corporation 82801 PCI Bridge (rev e1)
```

00:1f.0 ISA bridge: Intel Corporation 82801GB/GR (ICH7 Family) LPC Interface Bridge (rev 01)

00:1f.2 IDE interface: Intel Corporation 82801GB/GR/GH (ICH7 Family) Serial ATA Storage Controller IDE (rev 01)

00:1f.3 SMBus: Intel Corporation 82801G (ICH7 Family) SMBus Controller (rev 01)

01:00.0 PCI bridge: Integrated Device Technology, Inc. Unknown device 802f (rev 0d)

02:01.0 PCI bridge: Integrated Device Technology, Inc. Unknown device 802f (rev 0d)

02:02.0 PCI bridge: Integrated Device Technology, Inc. Unknown device 802f (rev 0d)

02:03.0 PCI bridge: Integrated Device Technology, Inc. Unknown device 802f (rev 0d)

0b:00.0 Ethernet controller: Broadcom Corporation NetLink BCM5789 Gigabit Ethernet PCI Express (rev 11)

0c:02.0 VGA compatible controller: ATI Technologies Inc RV280 [Radeon 9200 PRO] (rev 01)

0c:02.1 Display controller: ATI Technologies Inc RV280 [Radeon 9200 PRO] (Secondary) (rev 01)

0c:06.0 RAID bus controller: <pci_lookup_name: buffer too small> (rev 13)

Chapter 4 Install Cards and Drives

This chapter provides information on how to install 3rd Party PCIe cards or hard drives into your Magma expansion chassis. More details on the installation of individual cards are provided by the card's manufacturer. This chapter is provided as a simple guide to help you install your PCIe cards, or hard drives, in the chassis.

For the purpose of installation, the Magma EB2 functions exactly as a standard desktop computer chassis. Always follow the manufacturer's instructions for installing their card or hard drive on a desktop computer.

IMPORTANT



We will provide reasonable technical support with 3rd Party PCIe cards or hard drives. However, if you have verified a successful installation of the Magma expansion system (as defined in [Chapter 3](#)), but experience difficulty installing your 3rd Party PCIe cards or hard drive, the card or drive manufacturer should be able to provide the best support.

1 Remove PCIe Expansion Chassis Cover

By design, the top cover of the chassis is divided in two: One portion, covering the card expansion bay can be removed by simply unscrewing a thumbscrew on each side of the chassis (see photo below).

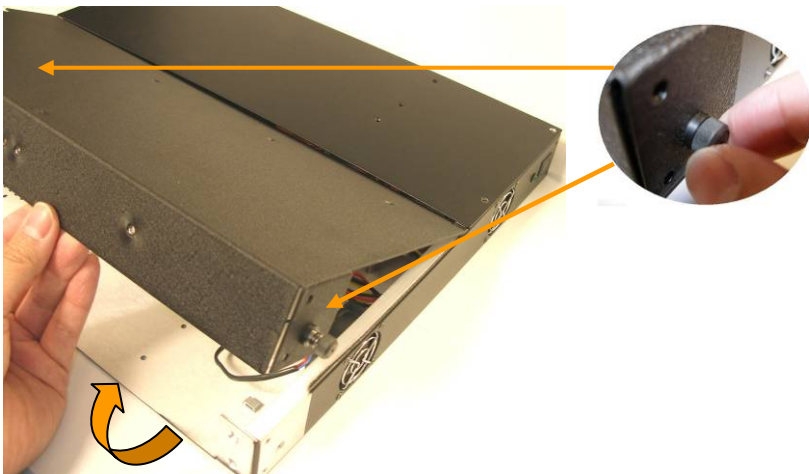

The second portion, covering the power supply and other circuitry being less frequently accessed is secured with seven (7) regular screws. To remove that portion of the cover use a regular Phillips-head screwdriver.

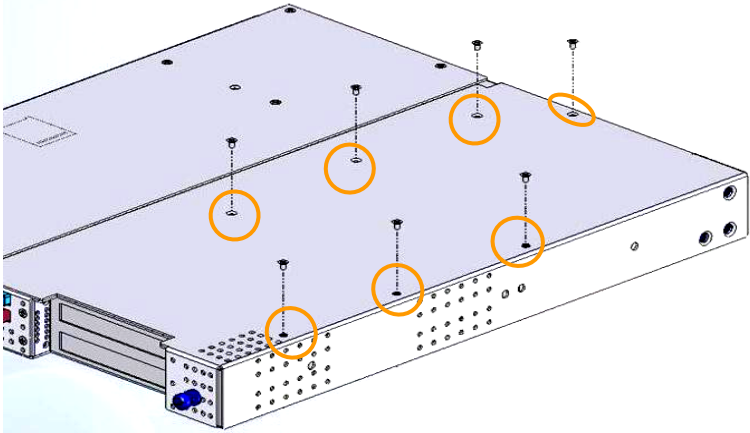

2 Install 3rd Party PCIe Cards

When installing 3rd Party PCIe cards into the Magma expansion chassis, it makes no difference which PCIe slot you place your cards in. Usually that is determined by accessibility and heat dissipation considerations as may be specified by the card manufacturer.

Install the PCIe peripheral cards following the card manufacturer's recommendations. Some PCIe card manufacturers recommend that you install their software driver(s) prior to installing the hardware. If this is the case, you should install their driver before you connect and power up the expansion chassis.



CAUTION

Please ensure that the current ratings specified on the power supply label are not exceeded as a result of installing PCIe cards or hard drives.

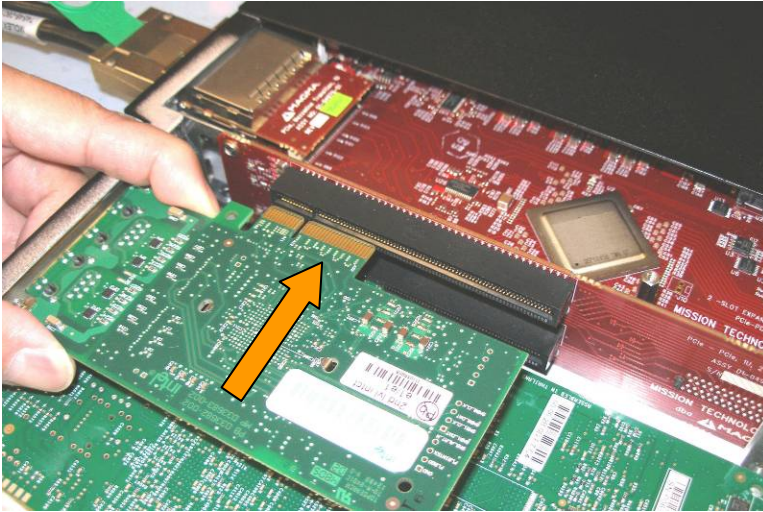

Make sure that all PCIe cards are fully seated in their connectors. When correctly seated in its connector, you will notice a firm resistance when you pull up gently on the card. To keep the cards in place, secure them in the enclosure with their retaining screws (supplied with the Magma expansion chassis).

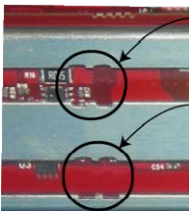

Card Slot #1 Adjuster
Rotate Connector

Card Slot #2 Adjuster
Rotate Connector

If your PCIe card is too short for the adjustable card slot guides, you can rotate the slot guard to make it fit. Simply loosen the adjustment screw for the slot you are using and slide the guard to pivot hole, as shown, and remove it. Next, rotate the slot guard 180° and reinsert it. Finally, adjust the card slot guard to fit

the card's length.

IMPORTANT



The sheer number of PCIe cards and device drivers available makes it impossible for Magma to fully test and certify all available PCIe cards for use in the Magma expansion chassis. Our best advice to you in this regard is to insist on full PCI Express Specification compliance from your card and system vendors. Cards and systems should be at least compliant with PCIe revision 1.0 or better. Compliance in your system motherboard, PCIe cards, and console firmware (or BIOS) is your best assurance that everything will install and operate smoothly.

Installing Double-Wide PCIe Video Cards

Double-wide PCIe video cards require special attention when being installed into the EB2 chassis. Not only do they require proper cooling, but we must also ensure adequate power for them to operate optimally. After verifying that the built-in power supply can adequately power the video card, connect it into the lower PCIe slot and be sure to connect the appropriate auxiliary power connector to the card as follows:

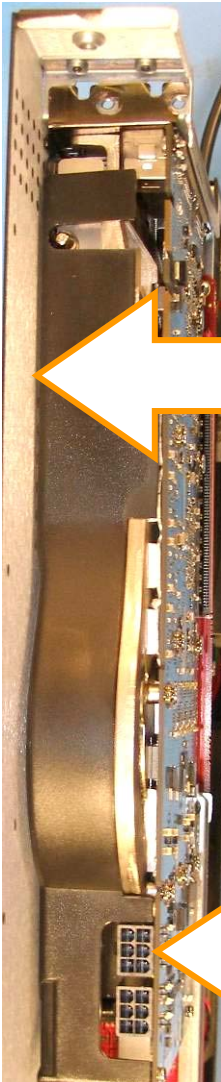

IMPORTANT

Double-wide video cards require proper air circulation in order to remain cool. For that purpose the chassis has a special ventilation cutout behind the cards' fan. Blocking it from the outside should therefore be avoided whenever possible.

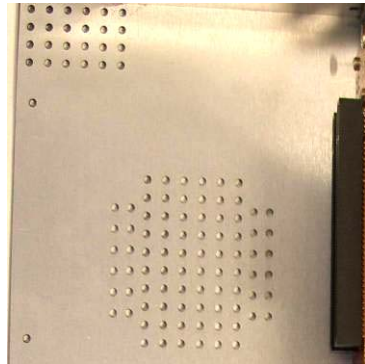

Connect the auxiliary power connector here. In any case of discrepancies between the sample card shown here and the one to be installed, please follow the card vendors' installation instructions.

3 Install Hard Drive(s)

The EB2 chassis can accommodate up to two 3.5" or 2.5" hard drives. Before installing hard drives in your system you should locate the brackets on which they will be installed. A pair of brackets should be preinstalled in the chassis while a second pair should be provided separately from the chassis as shown below:

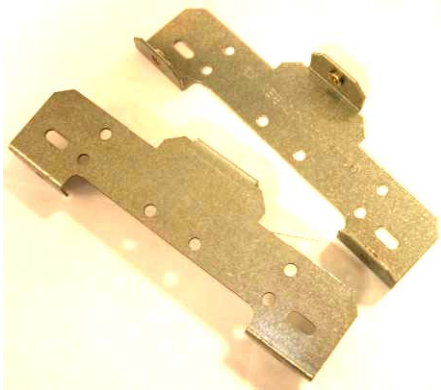

Once identified, mount your hard drive(s) to the hard drive bracket using two screws on each side of the hard drive as shown below:

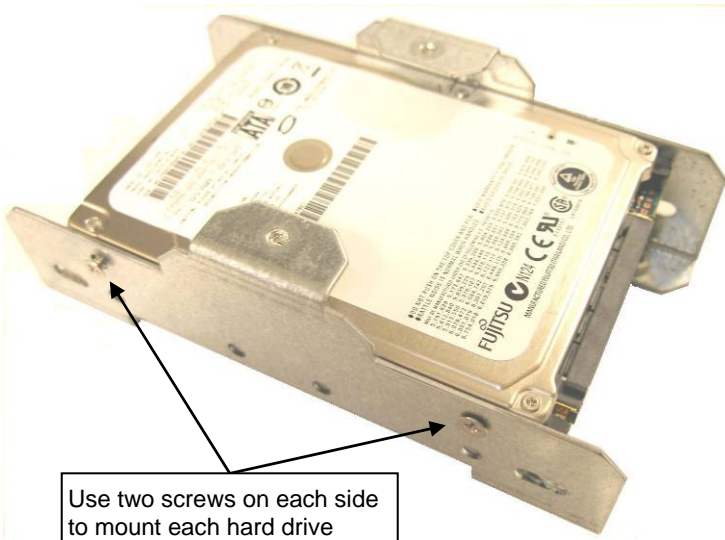

Use two screws on each side to mount each hard drive

Note that a PCIe hard drive controller card must be installed in one of the two PCIe slots for the hard drive(s) to interface with the host system. However that controller card should be no longer than PCIe half-length in order to accommodate a second (optional) hard drive in the area designated as zone 2 below:

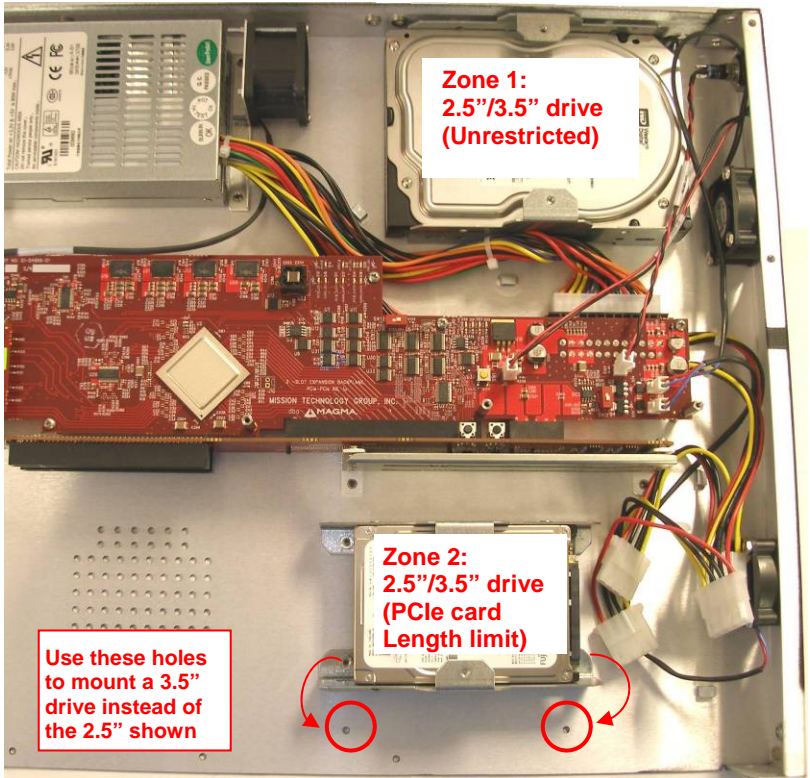

Both zones feature six holes in the base of the chassis so that both 2.5" and 3.5" drives with their respective brackets can be installed in the system.

Finally secure each of the installed hard drive(s)' brackets from the bottom of the chassis with two screws per bracket. Then be sure to connect the power and data cables to the newly installed hard drive(s).

4 System Should Be Up and Running

As noted previously, apply power to the Magma expansion chassis first, then power up the computer.

Use the procedures detailed in [Chapter 3](#) to confirm proper card installation(s). When everything is functioning correctly, your Windows Device Manager should look something like this for any given slot:

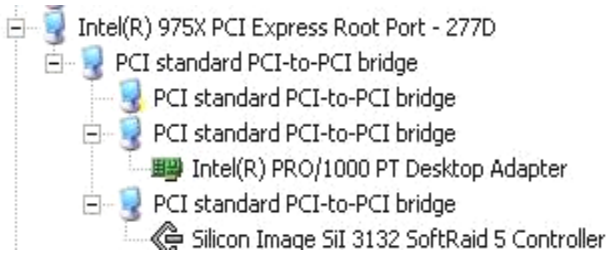

If you discover that any of your 3rd Party PCIe cards contains a  (exclamation mark) you have a problem with that card.

Refer to [Chapter 5 Troubleshooting](#) for further guidance.

5 Finishing Touches

Once your system is working properly, replace the host computer and the expansion chassis covers.

Last, if you previously installed the rack-mounting brackets, simply slide and secure the chassis in its place within the rack cabinet.

It is advisable for the chassis to be turned off while docking it into the rack cabinet. If it cannot be turned off, pay special attention to the iPass and power cable management prior to plugging them into the chassis.

“Hot-Swappable” PCIe Card Installations

New PCI Express technology allows you to remove your 3rd Party PCIe cards for maintenance or replacement – without shutting down the system. The EB2 expansions system supports Hot Plugging/Hot Swapping of cards as defined by the PCI express specifications.

By design, this feature allows the host PC to gracefully remove power to a slot, so that a PCIe card can be removed and replaced. It then powers on the new card in coordination with the PC's operating system. By default, the EB2 ships with this feature turned on.

IMPORTANT

There are cases in which you would wish to turn off this feature, especially if the PCIe cards you plan on installing in the EB2 chassis require or adhere to a different timing budget than allowed in the PCIe specifications.

In order to turn off Hot-plug/Hot-swap simply toggle the SW13 DIP switch from its default right position to the left as shown below:

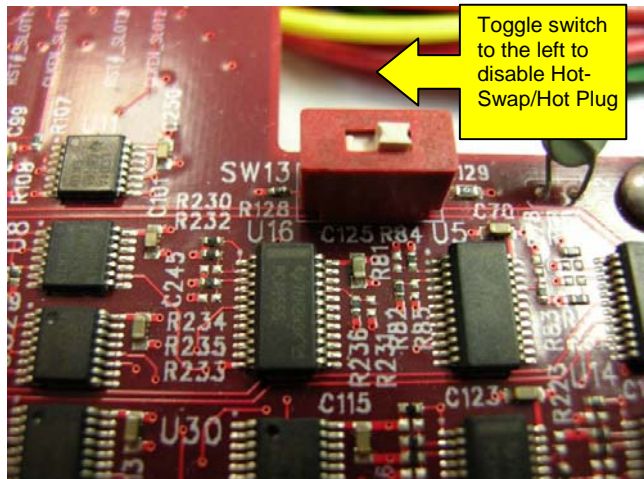

If you have any doubts, please check with your card's vendor that no such constraints exist for this card.



For this feature to work, you need to install the Magma software driver. See [Chapter 6](#) for instructions on how to download the latest software for your system, should you require this feature.

Each of the PCIe slots is controlled by a Hotplug Button as seen below:

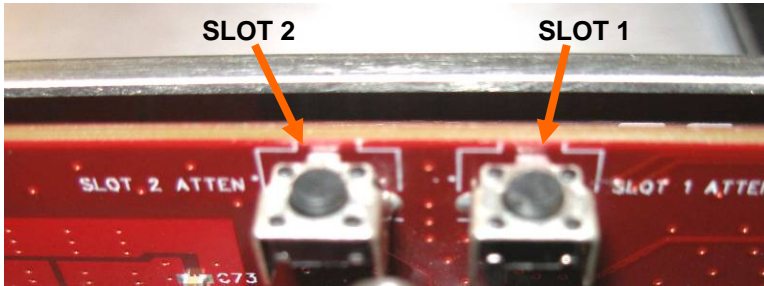

Simply press the button corresponding to the slot you wish to “power-down.” The power will now be removed from that slot so that the card can be replaced. All other PCIe cards remain fully functional, as they are independent of this slot. Below is the outlined procedure step-by-step:

Procedure for hot-un-plugging a PCIe plug in card:

1. Given a stable Windows-based system booted with the Magma chassis, an applet on the right hand side of the start menu bar should appear depicting a card with a green arrow above it.



Double click on the applet.

2. A dialog should appear with the title “Safely Remove Hardware” in the dialog will be a list of devices that may be removed from the system. Within this list will be the cards currently plugged into the chassis.

Select a device and click on the “Properties button”.

3. If the device is currently in the Magma chassis, the location will show “Magma chassis x slot y”. Where x identifies the physical chassis and y identifies the slot the device is plugged into.

After verifying that this is the device to be removed, click

on the OK button to close the new dialog.

- The properties dialog should close and the original “Safely Remove Hardware” dialog should remain.

Click on the Stop button of the dialog.

- A dialog with the title “Stop a Hardware device” should appear. This device is used to confirm that the user wishes to stop this device.

Click on the OK button of the new dialog.

- After a brief period a pop up will appear telling the user that the device may be removed safely, and the device will be removed from the list of the original dialog.

Press the Attention button that corresponds to the slot where the device is located.

- An LED, labeled *SLOT X Attention* (where **X** corresponds to the slot number) will begin to flash. The LED is located on the vertical backplane towards the back edge of the chassis as shown below:

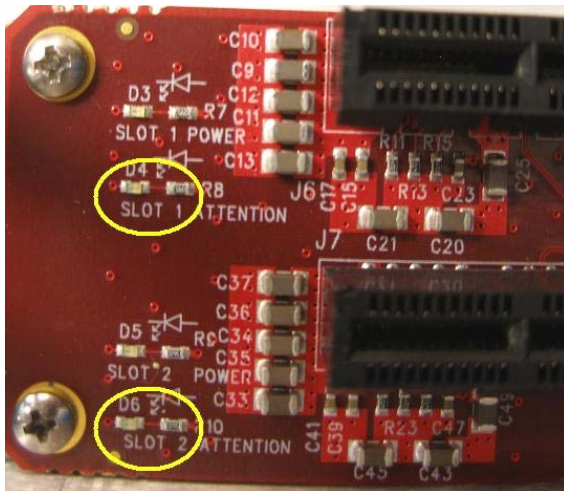

Note: If, by mistake, you’ve pressed the button corresponding to the wrong slot, then press it again within 5 seconds and the hot plug request will be ignored. Otherwise continue to step 8.

M A G M A

8. After 5-6 seconds the LED will stop flashing and turn off completely.

Remove the card and replace it with a new one, then press the button again.

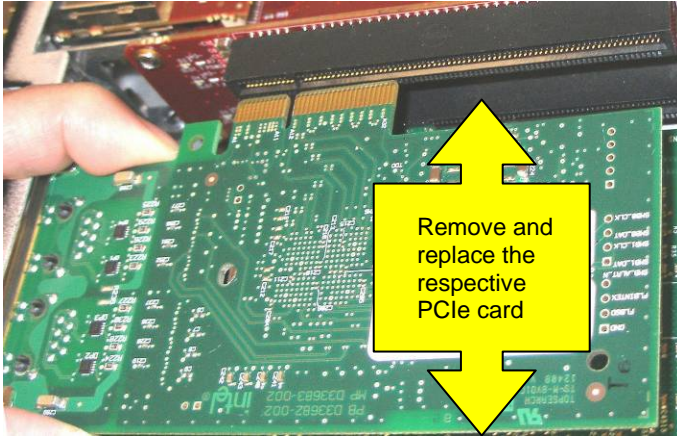

Ideally the PCIe card that was removed from the system will be replaced with an identical, working card. Replacing that card with one that has a different function or purpose may cause the system to crash due to a mismatch in the resources pre-allocated by the operating system.

9. The LED should start flashing again.

If power should not be applied to this slot, immediately press the button again and the LED will stop flashing and remain off, otherwise go to step 11.

10. After 5-6 seconds the LED will stop flashing and remain on.

After a brief period the new device will be recognized by the system, and it should be added to the list in the “Safely Remove Hardware” dialog

PCIe Expansion Solutions with the EB2

In the following section we will take a look at possible PCI Express expansion solutions using Magma's EB2 chassis.

Digi Design Pro Tools®

Pro Tools® is a comprehensive solution for professional music editing. It offers advanced capabilities for recording and manipulation of music by controlling a large number of music tracks.

This is done using at least one PCIe card with multiple Digital Signal Processor (DSP) chips onboard. From a system's standpoint, the more PCIe cards (and hence DSP chips) are available, the more tracks can be edited and recorded digitally for a better final result.



By combining the power of PCIe expansion through an EB2 system with multiple such PCIe cards, the same PC can record substantially more tracks. Additionally the same system may contain a storage controller (SAS/SATA/SCSI) and the hard drives for actually recording the tracks – all inside one box, freeing much of the PC hardware for other tasks.

The table below shows a comparison between PCI and PCIe cards in terms of the number of recorded tracks.

Sampled Frequency	No. of tracks out of maximum possible	Description/Notes
48KHz	192 out of 192	Using Magma ExpressBox2 PCIe Expansion system
96KHz	96 out of 96	
192 KHz	36 out of 36	
48KHz	144 out of 192	Using Magma CB2 PCI Expansion
96KHz	96 out of 96	
192 KHz	13 out of 36	

M A G M A

Note that the maximum number of tracks is achieved with all PCIe cards inserted directly into the PC. Using the EB2 expansion chassis we note the difference in track counts is no larger than 20% compared to a scenario where all cards reside in the PC, taking up all available slots.

Video Card expansion solutions

Magma's EB2 chassis can be used to add a high end PCI express video card to a PC system or laptop that were not equipped with such a device for various reasons: cost , physical space, heat dissipation etc.

A question then arises as to how good of a performance we can get by utilizing the expanded PCIe bus and high end video card . In order to obtain a definitive answer we turn to Futuremark's 3DMark® benchmarking software. Since its introduction at the turn of the millennium, 3DMark® has become the de-facto standard in Video card performance testing and evaluation.

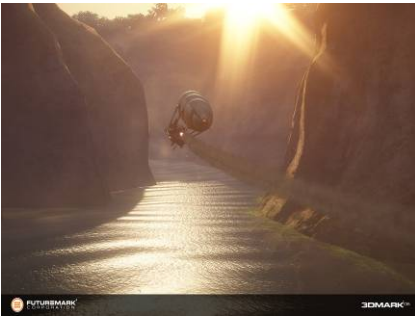
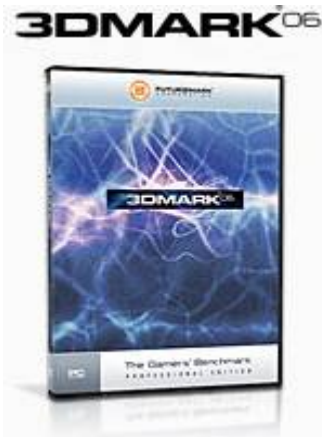

The 3DMark® suite is optimized to work under Windows Vista and supports the latest DirectX and derivative 3D multimedia technologies. In this environment, a low-profile Dell PowerEdge server (with a built-in ATI ES1000 video chipset) was tested with various external PCIe video cards.

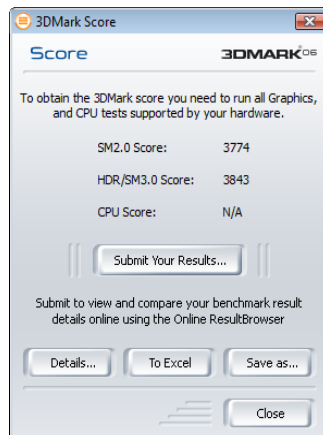

Since the built-in video chipset doesn't support 3D rendering needed to run 3DMark®, we first established a baseline by installing an entry level PCIe card into an EB2 expansion chassis (Nvidia Quadro NVS440).

All subsequent benchmarks were completed using higher performing video cards and documented in the table below:

Tested Video Card	SM2.0 Benchmark Score	SM3.0 Benchmark Score
NVidia Quadro NVS440	151	182
NVidia Quadro FX560	229	479
ATI 1650 Pro	757	773
NVidia GeForce 7600GS	861	768
NVidia Quadro FX1500	1048	979
NVidia GeForce 7900GS	1582	1528
ATI 1900XT	2286	2504
NVidia Quadro FX5600	3678	3412
NVidia 8800 Ultra	3774	3843

The comparison table shows performance improvements from 263% to 2111% between the baseline and the highest-end video card tested (the NVidia GeForce 8800 Ultra). In other words, by expanding the PCI Express bus, the EB2 system was able to facilitate an ever-improving benchmark result limited only by the 3rd party card's performance and the bandwidth limitations of the bus itself.

For more details on the actual test methodology and an explanation of the benchmark figures please refer to: www.futuremark.com

High Throughput storage solutions

The growing demand for storage solutions in the past few years was one of the major catalysts behind the exponential growth in hard drive capacity. Moreover, a new breed of faster and more efficient interfaces have emerged in order to provide higher throughput while maintaining the lowest possible delays in accessing our data.

One such solution is ATTO Technology's FC-44ES Fibre Channel PCIe controller. It can reach data transfer rates of up to 800MB/sec per channel when taking full advantage of the PCI Express bandwidth.



But what if this impressive performance is still not enough to satisfy a bandwidth-hungry application such as a multi-dimensional database, or a high-definition, real time, video streaming broadcast? In that case, the EB2 becomes an obvious solution by allowing the user to combine up to 4 Fibre Channel controllers into one system, which, in turn, only compromises a single PCIe slot out of the ones available in the host computer.

Assuming we acquired the necessary hardware (controllers, the fiber medium and an array of high-speed storage devices) the question that arises is: How can we quantify the power of multiple controller cards? The answer lies in an open-source application, vastly popular among those working in the storage industry: iometer® (see screenshot below)

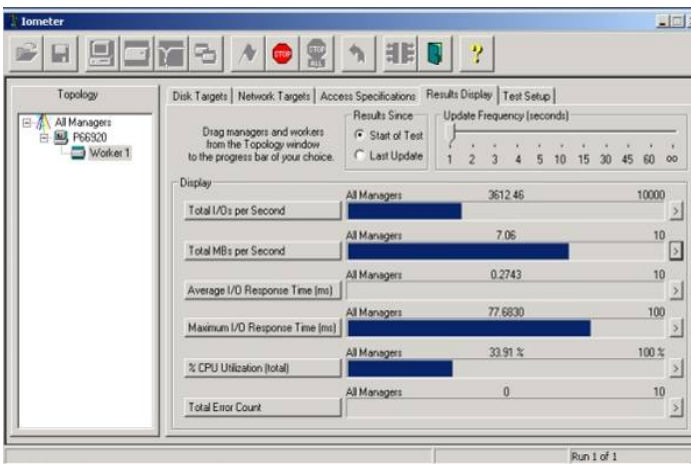

lometer® is a software-based I/O exerciser capable to test and characterize stand-alone as well as clustered storage systems. Developed originally by Intel as a proprietary tool, it eventually became part of the Open Source Development Lab (OSDL) from which point it has undergone several revisions and updates.

Going back to the Fibre channel host controller cards, one of the features that the ATTO FC-44ES supports is the creation of multiple, small virtual drives that can be striped by the OS for faster access. What that translates to is the ability of two cards to communicate amongst themselves at the fastest possible rate, unaffected by delays otherwise encountered by moving parts in an actual disk drive.

By using this method combined with the lometer® application, one can benchmark the communication channel and verify that the PCIe express link is utilized to its fullest potential.

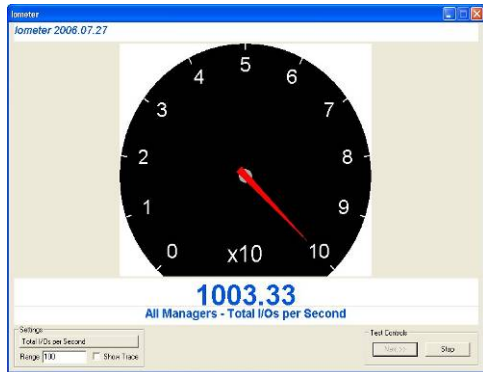

In the example below, a single ATTO FC-44ES card was installed into one of the 4 PCIe expansion slots provided by the EB2 chassis. It was then connected via fiber optic cables to a second FC-44ES card (set to simulate a fibre disk array, by using a striped set of small virtual drives). Three tests were performed using lometer. In the first, an equal amount of read and write threads were exercised between the two cards. The following two tests focused on either all-read or all-write threads. The test results are shown in the table below:

I/O Test type	Throughput [MByte/sec]
50% Reads; 50% Writes	1003.3
100% Reads	696.1
100% Writes	677.7

The results show an aggregate throughput exceeding 1GByte in the case where reads and writes are evenly split 50-50 and a slower, more realistic rate when only a single type of threads was exercised.

Chapter 5 Troubleshooting

Locate the Problem

If you are having trouble with the Magma expansion system, first verify that all cards and cables are seated properly. Be sure you followed the instructions in earlier sections of this User Guide. Always remember to power **On** and **Off** correctly when rechecking your installation. If you are still having problems, try these troubleshooting steps:

- [My Computer Can't Find the PCIe Expansion System](#)
- [When Nothing Works](#)
- [My PCIe Card Doesn't Work](#)
- [The System Fans Don't Appear To Spin Fast Enough](#)

The Magma PCIe Expansion System is correctly displayed as a “**PCI standard PCI-to-PCI bridge**” in Windows Device Manager and as a “**pci-bridge**” in the MAC Apple System Profiler and in Linux. When connected and functioning correctly, this Expansion System will be displayed as follows:

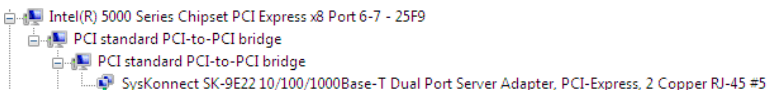

Windows

pci-bridge	pci	PCI	SLOT-2
pci-bridge	pci	PCI	SLOT-2
pci8086,1107	Ethernet Controller	PCI	9x9

MAC

If this is not what you see when you verify your installation, the following troubleshooting steps may help you locate and resolve your installation issues without having to call Technical Support.

My Computer Can't Find the PCIe Expansion System

If the expansion system is not visible in your Windows Device Manager or your Apple System Profiler at all, you will need to turn off your computer (first) and then the Magma expansion chassis (second) and test all cords and cables to ensure you have everything connected correctly. If everything seems to be connected correctly, and you are sure you have applied power correctly (power up the expansion chassis first and then the computer), then try the following troubleshooting steps:

- Verify that the required LEDs on the back of the chassis are lit. The most important indicators are the LINK LEDs that indicate a proper connection. All LINK LEDs should be ON if both PCIe slots are populated and both an uplink and a downlink iPass cable are connected properly. In the example shown below, we see all but the DNLNK LEDs are on indicating that the downlink cable is not connected, but otherwise all is functional. The ACT (activity) LEDs will light/blink only upon data transfers between host and expansion. They can be off so long as the required LINK LEDs remain on.

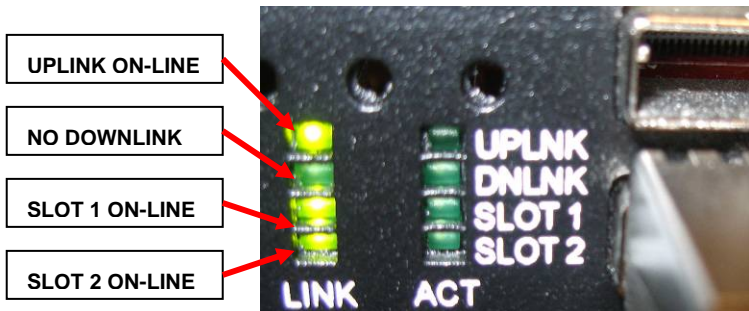

- Also verify the Magma PCI Express Host card is properly inserted into the host computer slot. In case any other LED is off, ensure the respective card is functional and properly seated in its ExpressBox slot.
- Try moving the PCIe host card to a different PCIe slot.
- If the expansion system is still not visible after trying all of the above steps, go to [Chapter 6](#) to get additional help.

M A G M A

Windows

If the PCI-to-PCI Bridge is now visible, but contains a  (exclamation) in front of it, it has a problem that must be fixed.

To identify this problem, right-click on the line with the  and select "Properties" from the pop-up menu.

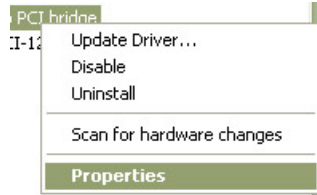

Resolve the identified problem or go to [Chapter 6](#) to get additional help.

MAC

Go to [Chapter 6](#) to get additional help.

RedHat9 Linux

Go to [Chapter 6](#) to get additional help.

When Nothing Works

The following troubleshooting steps will help you when the computer or chassis won't turn on or "nothing seems to work" correctly:

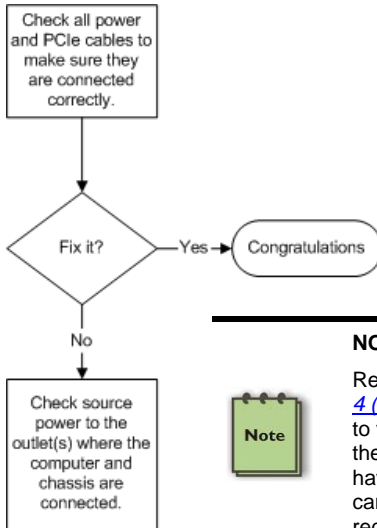

NOTE



Review Chapters [3 \(Verify Installation\)](#) and [4 \(Install Cards and Drives\)](#) as necessary to verify that you have a valid installation of the Magma expansion system and that you have correctly installed your 3rd Party PCIe card(s) and their associated drivers (as required).

If it powers up OK, but nothing works, check the computer's Device Manager or System Profiler to see if the expansion system has been found. If not found, try the troubleshooting steps for [My Computer Can't Find the PCIe Expansion System](#). If the expansion system is visible, but has a problem, try to resolve the problem (See Note above). If that fails, go to [Chapter 7](#) to get additional help.

My Computer Hangs During Power Up

If your computer “hangs” while being turned on and you can’t even start, follow the following steps to try to fix this problem:

1. Shut off the computer (first) and then the Magma expansion system and verify that all cards and cables are connected and seated correctly.
2. If it still hangs and you have added one or more hard drives in addition to several PCIe cards, ensure that you have not exceeded the power capabilities of the expansion system’s power supply. You can verify the capacity of your power supply by checking the label on the power supply. If you are not certain about the power consumption of your peripherals, it is best to remove them one by one (starting with those you suspect of being most “power hungry”) until the system powers up.
3. If you have removed all 3rd Party PCIe cards from the Magma chassis and it still hangs, try the following:
 - a. Remove the Magma PCIe expansion host card from the computer and try booting up without the Magma expansion system attached.
 - i. If it boots up OK without the Magma expansion system attached, call Magma Technical Support.
 - ii. If it still hangs, the problem is in the computer and not with the Magma expansion system or the 3rd Party PCIe cards.
 - b. If it boots up OK without any 3rd Party PCIe cards installed, try adding only one card and see if it boots up.
 - i. If it boots up OK with one card in it, shut it down and swap cards. Repeat this until all cards have been tested. If they all test OK, then add them back one at a time until you find the combination that doesn’t work. If you find a bad card, call Technical Support. If you don’t – congratulations, you fixed it!
 - ii. If it still hangs up, try a different card – this one is probably bad (or has driver problems). If the second card works, troubleshoot the first card. If the second card also fails, call Technical Support.

My PCIe Card Doesn't Work

The following flowchart describes a general approach to resolve PCIe card issues:

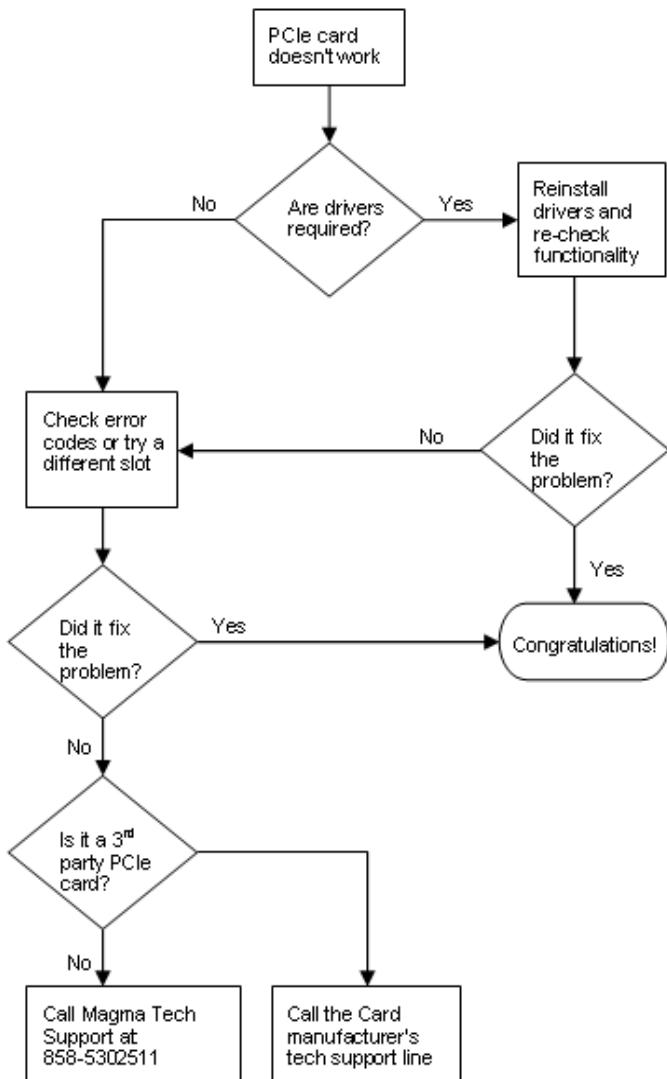

The following additional steps might also help when the above troubleshooting steps fail to resolve your problem:

M A G M A

1. Shut down the computer followed by the Magma expansion chassis
2. Remove the PCIe card displaying a problem
3. Replace the “problem card” with a *simple* PCIe card, such as an Ethernet card that has drivers built into the operating system. (*Using this “type of card” will avoid any future questions about drivers possibly being installed incorrectly.*)
4. Turn on the Magma expansion chassis, and then turn on the computer.

Windows

5. Next, open the Device Manager (View by Connection selection).

If the  is gone, the problem is with the 3rd Party PCIe card or the card drivers. You should go to the [Windows Error Codes](#) section of this chapter to learn how to troubleshoot using error codes.

If the  is still visible, the problem may be with the Magma expansion system. Please contact Magma Technical Support for further guidance and/or a replacement product.

MAC

5. Next, open the Apple System Profiler and the 3rd Party PCIe card(s) should now be visible.

RedHat9 Linux

5. Using the **lspci** command, verify that the PCIe card is visible.

Support for 3rd Party PCIe Cards

Magma will provide reasonable technical support to with 3rd Party PCIe cards. However, if you have verified a successful installation of the Magma PCIe Expansion System (as defined in [Chapter 4](#)), but experience difficulty installing your 3rd Party PCIe cards, the card manufacturer should be able to provide the best support.

IMPORTANT



The Magma PCIe Expansion System is designed to function exactly like your desktop computer. This means that you should follow the card maker's instructions for installation on a Windows or Mac computer as if the expansion chassis WAS the desktop computer. When correctly installed, there is no difference to the operating system, removable cards, or most software.

Windows Error Codes

If you are having a problem with one of your devices, and the Device status box shows a Windows Error Code, refer to the following list of error codes for guidance:

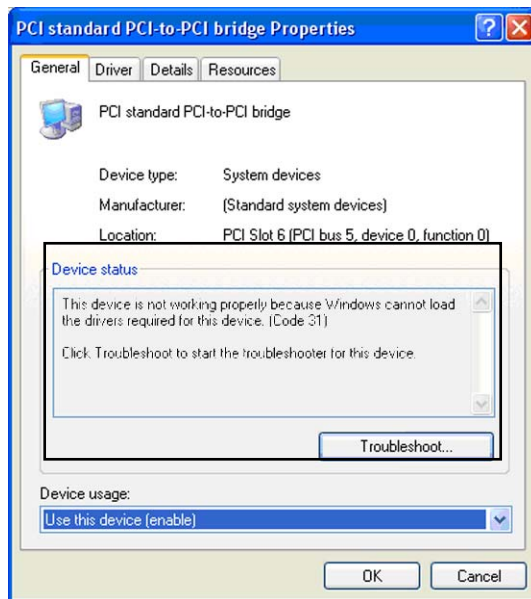

Error Code	Description/Action
10	<p>This code indicates that there is a problem with the 3rd Party PCIe Card driver.</p> <p>If necessary, contact the card's manufacturer for updated software drivers. If all else fails, contact Magma Technical Support for further assistance.</p>
12	<p><u>On the Bridge:</u> If you receive error code 12 on the first PCI to PCI Bridge, call Magma Technical Support.</p> <p><u>On the Card:</u> This usually means the memory, I/O, or prefetch is more than has been allocated. Call Magma Technical Support.</p>

Error Code	Description/Action
28	<p>The driver for the PCIe card is not installed on your system. Reinstall the card driver following the manufacturer's instructions. If that fails to fix the problem, call the card manufacturer for new drivers.</p>
1	<p>The PCIe host card or expansion chassis are not working correctly. Reinstall the PCIe host card into the computer's slot and recheck all cable connections. If the error code remains, try another PCIe slot. If the error persists, call Magma Technical Support.</p>
Other Codes	<p>For all other error codes, call:</p> <p><u>On the PCI to PCI Bridge:</u> Magma Technical Support</p> <p><u>On the Card:</u> Card Manufacturer's Technical Support, after first verifying that the Magma expansion system is installed properly.</p>

If you are still having problems, contact Magma Technical Support for more help.

The System Fans Don't Appear To Spin Fast Enough

The EB2 chassis is equipped with three fans: One for the power supply and two for the chassis.

The power supply fan should always rotate at full speed, while the two chassis fans are thermally controlled both for acoustic and increased reliability reasons. In other words, those fans can adjust their rotation speed based on the user's preference as well as the amount of heat dissipated by the components inside the chassis. Switches SW10 and SW11 (see their location below), are the ones who determine whether the two chassis fans should automatically regulate their speed based on the temperature inside the chassis or rotate at full speed nonetheless.

SW10 Position:

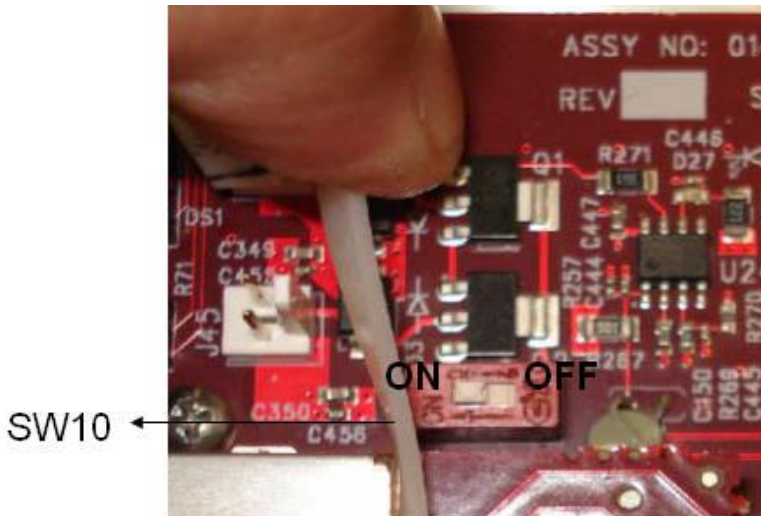

SW11 Position:

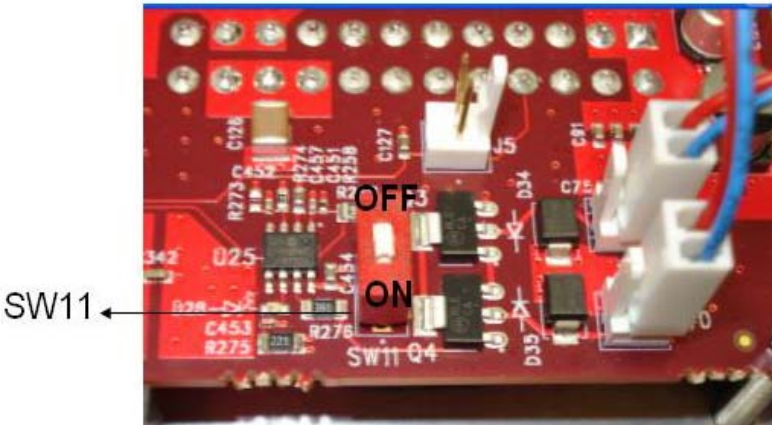

By default, the EB2 system comes with the two switches in the OFF position (meaning, that their speed is thermally controlled automatically). By switching them ON, the user can effectively bypass this circuitry and set the fans' rotation speed to maximum.

This setting is particularly recommended if one plans on using double-wide PCIe video cards or other peripherals known to generate excessive heat, while the additional noise generated by the fans is not a concern.

Chapter 6 How to Get More Help

Frequently Asked Questions (FAQ)

You can visit the Magma Technical Support FAQ pages on the Internet at:

www.magma.com/support/

Contacting Technical Support

Our support department can be reached by fax at (858) 530-2733 or by phone at (858) 530-2511. Support is available Monday through Friday, 8:00 AM to 5:00 PM PT. When contacting Magma Technical Support, please be sure to include the following information:

- | | |
|------------------|--|
| 1) Name | 7) Serial Number |
| 2) Company Name | 8) Computer Make |
| 3) Phone Number | 9) Computer Model |
| 4) Fax Number | 10) Operating System and Version |
| 5) Email Address | 11) Make/Model of PCI cards in expansion chassis |
| 6) Model Number | 12) Detailed description of the problem |

You can also visit our web site at:

www.magma.com/support/

For a quick response, use the Technical Support and RMA Request Form available in the Support Section of the website. Simply complete the form with all required information. Please make sure that your problem description is sufficiently detailed to help us understand your problem.

For example: Don't say "Won't boot up." Do say "Tried all the steps in the Troubleshooting Section and it still won't boot up."

For faster diagnosis of your problem, please run the two utility programs described in the following sections and include the diagnostic files they generate with your email.

Magma Debug Utility

Occasionally, Technical Support may request Windows users to produce and email a Magma debug log file to help them resolve your problem. This file should be included as an attachment when submitting a Technical Support request at www.magma.com/support.

1. Locate a file called **dbgview.exe** on the Magma CDROM.
2. Double-click on the file **dbgview.exe**
3. While the **dbgview** screen is open, locate and double-click on a file called **dump.exe** on the Magma CDROM.
4. Switch back to the **dbgview** screen, which is now filled with data.
5. Save the file and include it as an attachment when submitting a Technical Support request.

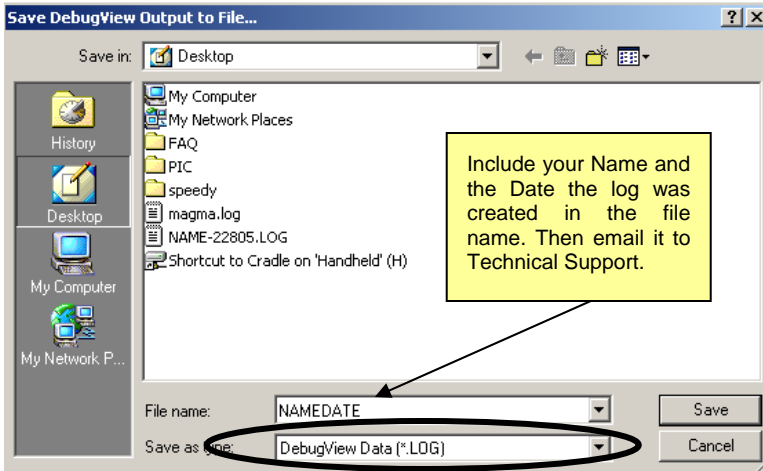

Use the "Save as type" drop-down arrow to select a file type of (*.LOG).

PCIScope Software Utility

PCIScope is a powerful tool for Windows users. It was designed by a Germany company called APSoft. This software utility is a valuable resource to explore, examine and debug the PCI subsystem of your computer. It was made to fit the requirements of the most demanding users, especially engineers, programmers, and system administrators, and to integrate all advanced functions and tools into one product. Please visit www.tssc.de for more information about the capabilities of **PCIScope** and other utilities offered by APSoft.

An evaluation version of **PCIScope** is available for download at www.tssc.de. (You can purchase an inexpensive license from APSoft for use beyond the evaluation period.)

PCIScope has proven to be extremely useful when verifying and debugging configurations involving the Magma PCI Expansion Systems under any Windows platform.

PCIScope can provide information to you and our Technical Support Group such as PCI Bus Numbering, Resource Allocation, and other information that may prove useful when debugging expansion chassis or PCI card problems.

If you are experiencing problems setting up your system, you should run **PCIScope** before contacting the Magma Technical Support Group.

With the Magma expansion chassis powered up and connected to your computer, load and launch the **PCIScope** application. The **PCIScope** Program will be installed on your computer and a window similar to the one shown below will appear. (The example was taken from a Compaq Armada 7400)

PCI Scope - [C:\WINDOWS\DESKTOP\SAMPLE.BPD]

File Edit View Descriptions Tools Window Help

Bus 00h

- Multifunctional device (C...
- 00:00 Compaq - DRA
- 00:01 Compaq - DRA
- Cardbus bridge (Texas In...
- 0C:00 Socket 0**
- 0C:01 Socket 1
- Multifunctional device (C...
- 0E:00 Compaq - CET
- 0E:01 Compaq - Trifite
- 0E:02 Compaq - USB

Bus 01h

- 00:00 S3 Inc - 86C260 V...

Bus 04h

- 00:00 Digital Equipment C...

Bus 05h

- 04:00 Digital Equipment C...

Bus 06h

- Multifunctional device (Br...
- 04:00 Brooktree Corp
- 04:01 Brooktree Corp

Bus 03h

Information | PCI Registers | PCI Registers form

PCI1250 PC card CardBus Controller
CardBus Bridge
Bus 00h : Device 0Ch : Function 00h

Vendor ID : 104Ch (Texas Instruments (TI))
Device ID : AC16h (PCI1250 PC card CardBus Contro...
SubVendor ID : 0E11h (Compaq)
SubDevice ID : B048h (Unknown)
Revision ID : 02h

Base class code : 06h (Bridge Device)
Sub-class code : 07h (CardBus Bridge)
Programming interface : 00h (CardBus Bridge)

Header Type : 82h (CardBus bridge, Multiple functio...
Built-In Self-Test : No

Bridging Information

PCI bus number : 00h
CardBus bus number : 04h **PCI Bus Numbering**
Subordinate bus number : 06h

Filter Settings

Reg.	Type	Base	Limit	Size	Comment
0	Mem				
1	Mem	D0000000h	D01FFFFFFh	00200000h	2 MB. Prefetchable.
0	I/O				
1	I/O				

Resource Allocation

CardBus socket Registers/ExCA

Base address Register : 7FFFFFF00h (Locate anywhere in 32 bit ...)

Interrupt Line : IRQ 11 (0Bh)
Interrupt Pin : INTA

Device Configuration

Command register : 07h

I/O space access : Enabled **It's a good sign if any of these read "Enabled"**
Memory space access : Enabled
Bus master : Enabled
Special cycles operations : Disabled
Memory write and invalidate : Disabled

You should save this data as a file on your computer. Please include your name and date as part of the file name with an extension of ".bpd." This file should be included as an attachment when submitting a Technical Support request at www.magma.com/support.

Returning Merchandise to MAGMA

If factory service is required, a Service Representative will give you a Return Merchandise Authorization (RMA) number. Put this number and your return address on the shipping label when you return the item(s) for service. **Magma will return any product that is not accompanied by an RMA number.** Please note that Magma WILL NOT accept COD packages, so be sure to return the product freight and duties-paid.

Ship the well-packaged product to the address below:

MAGMA RETURNS DEPT.
RMA # _____
9918 Via Pasar
San Diego, CA 92126
USA

It is not required, though highly recommended, that you keep the packaging from the original shipment of your Magma product. However, if you return a product to Magma for warranty repair/ replacement or take advantage of the 30-day money back guarantee, you will need to package the product in a manner similar to the manner in which it was received from our plant. Magma cannot be responsible for any physical damage to the product or component pieces of the product (such as the host or expansion interfaces for the PCIe expansion chassis) that are damaged due to inadequate packing. Physical damage sustained in such a situation will be repaired at the owner's expense in accordance with Out of Warranty Procedures. Please, protect your investment, a bit more padding in a good box will go a long way to insuring the device is returned to use in the same condition you shipped it in. Please call for an RMA number first.

Appendix A Need More PCIe Slots?

Multiple PCIe Expansion System Configurations

The PCI Express Local Bus Specification defines the bus as *hierarchical*, where logical PCI to PCI Bridges (PPBs) may be used to add "levels" to the PCI bus hierarchy within a PCIe switch. Because hierarchies are *organized systems arranged into different levels*, you can take advantage of this automatic organizing and layering to expand the number of available PCIe slots beyond the number available in your computer's motherboard.

You can easily add two or more Magma expansion systems to your current system in either a "fan-out" or "daisy-chain" configuration. Each of these configurations has advantages and uses. To determine which type of configuration you wish to use, you should first understand a few basic facts:

1. In a desktop computer, the BIOS enumerates automatically behind logical PCI bridges. In the Magma configuration, the BIOS looks beyond the Host card to find any PCIe cards installed in the expansion chassis behind a PCIe switch. The PCIe switch, in turn, emulates logical PRBs. The BIOS can then configure the cards and allocate resources. Empty PCIe slots are ignored during configuration.



In theory, your computer "should" be able to travel across up to 255 PCIe buses to identify and configure all installed PCIe cards. The 255 PCI bus limit is actually a theoretical maximum. The practical limit is somewhat lower and differs from one system to another, but should still be a fairly large number.



In a desktop computer the bus numbers tend to be lower (0, 1, 2, etc.). Once the BIOS is finished configuring everything and assigning resources, the Operating System starts loading and activates the PCIe cards found.



When adding more Expansion Systems to an existing system, be sure to connect and test them "one-at-a-time." This will allow you to quickly resolve any connectivity, or other, issues right at the start. **DO NOT INSTALL any 3rd Party PCIe cards into any system until ALL attached systems are working correctly.**

2. Most computers allow multiple logical bridges (and thus PCIe buses) to be correctly configured. Some computers, unfortunately, place an arbitrary limit on the number of bridge levels that can be traveled during power-on configuration. Your computer "power-on-software" should be compliant with the PCIe bus specification 1.1 in order to effectively use a Magma PCIe Expansion System. For "fan-out" and "daisy chained" system configurations, where more than one PCIe expansion system is being used, you should count all of the logical bridge levels to your most deeply nested PCI bus to determine the maximum number of bridge levels that must be traveled. Exceeding this number may cause software configuration conflicts even though hardware-wise the PCIe system is properly configured.
3. For easier understanding, a given PCI system should be viewed as a "Resource Toll road" that runs from the computer CPU (resource home), through the "Toll Booths" (the PCIe switches and logical PCI bridges), to the "Resource Users" (PCIe Cards). As in the case of a real Toll Road, the more Toll Booths you have to cross (even if it takes a nanosecond), the longer it will take you (your data) to get from the PCIe Card to the CPU and back again. Under most circumstances the effect cannot even be detected. However, under other conditions, it can be important to know about.

Fan-Out

For reasons described in bullet #3 above, we recommend using a fan-out configuration when you need to add successive PCIe expansion systems to the host computer. This addition to the PCI bus hierarchy is at the "peer" level of other existing expansion buses, thus adding "breadth" to the PCI bus hierarchy, since these buses will be at the same hierarchical level within the system configuration.



You must ensure that you have the corresponding PCIe to PCIe Expansion System, or chassis to connect with your host card to support your desired configuration.

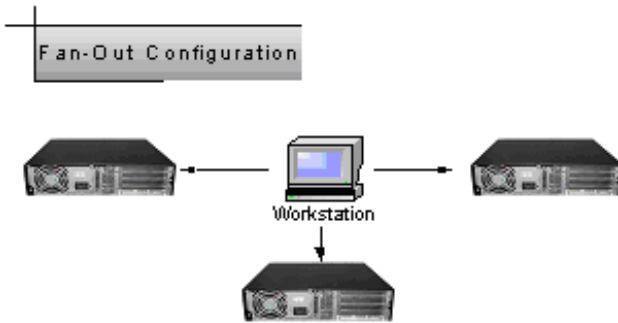

In this configuration, you have fewer "Toll Booths" to pass through; therefore the latency is shorter, however you've "sacrificed" another PCIe slot from the host computer, which may not always be an option.



For clarification, it is necessary to understand that the amount of latency caused by a PCIe switch (or a PCIe-to-PCI bridge built into some 3rd Party PCIe cards) is negligible ("nanoseconds") and will not produce any visible effect on most systems. It is only mentioned here because of certain specialized configurations involving unique PCIe cards with special software drivers. The total number of logical buses that the data must pass through COULD make a difference. See [Chapter 5 Troubleshooting](#) for more information if you suspect this could be an issue with one of your specialty PCIe cards.

Verify your configuration

Before you start installing your PCIe cards (refer to [Chapter 4 Install Cards and Drives](#) for more information), you should confirm that everything is in proper working order. Refer to [Chapter 3 Verify Installation](#) for guidance in verifying the proper installation of your Expansion System. For example, the following image shows the division within the Windows Device Manager display between two Expansion Systems connected in a “Fan-Out” configuration. In this case each expansion chassis offers only two slots of expansion.

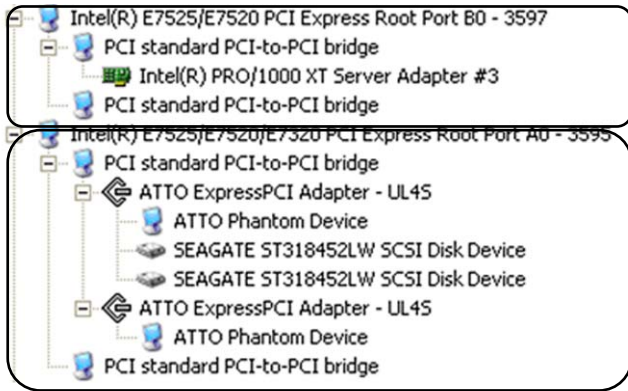

The following image shows the Apple Profiler display when a MAC has 2 Expansion Systems connected in a “Fan-Out” configuration

Card	Type	Bus	Slot
ATTO ExpressPCI UL45	scsi-2	PCI	ex9
ATTO ExpressPCI UL45	scsi-2	PCI	ex9
ATY,RADEON	display	PCI	bx9
bcom5714	network	PCI	GIGE
bcom5714	network	PCI	GIGE
GeForce 6600	display	PCI	SLOT-1
pci-bridge	pci	PCI	SLOT-4
pci-bridge	pci	PCI	SLOT-3
pci-bridge	pci	PCI	SLOT-3
pci-bridge	pci	PCI	SLOT-2
pci-bridge	pci	PCI	SLOT-2
pci-bridge	pci	PCI	SLOT-4
pci8086,1001	Ethernet Controller	PCI	7x9

Daisy-Chaining

Recognizing the typical insignificance of the performance variance between the “Fan-Out” and “Daisy-Chaining” configurations, the primary reason for using this one would be limitations on physical space. This could be the number of available slots on the host computer motherboard, or a lack of desk or rack space.

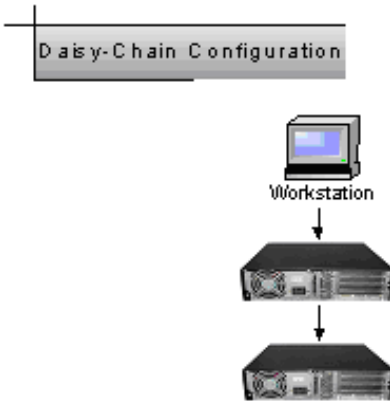

In the daisy-chain configuration, successive PCIe expansion systems are added to the "end" of the PCIe expansion hierarchy, which adds "depth" to the Local Bus by increasing the number of the logical PCI levels active in the system configuration.

Verify your configuration

Before you start installing your PCI cards (refer to [Chapter 4 Install Cards and Drives](#) for more information), you should confirm that everything is in proper working order. Refer to [Chapter 3 Verify Installation](#) for guidance in verifying the proper installation of your Expansion System.



NOTE

Notice that each Daisy-Chain unit appears in the Device Manager in the reverse order of its place in the configuration.

Combination Configurations

Depending on your business requirements, and your physical space limitations, you can add additional Expansion System in multiple configurations, such as these. These combinations are only limited by the availability of PCIe slots (both in the host and in subsequent chasses).

Fan-Out Daisy-Chain Combination Configuration

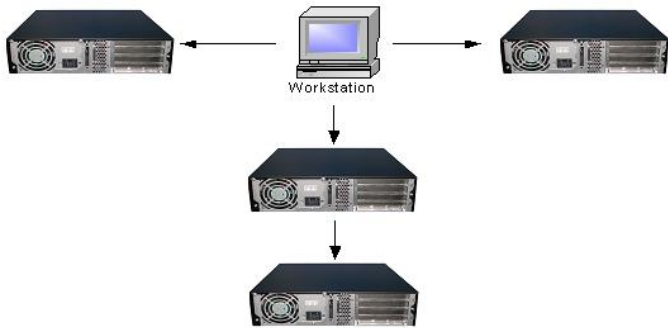

Daisy-Chain Fan-Out Combination Configuration

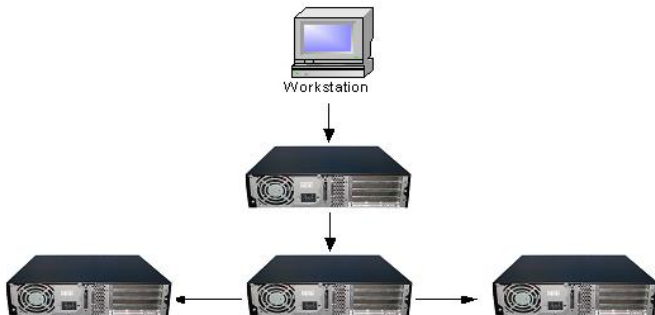

Obviously, you will need to keep an eye on your overall system's performance and make any required adjustments in an incremental manner such that the end result is a robust expansion solution.

PCI e Card Conflicts

If you determine that one PCIe card is interfering with the operation of another card, first try reorganizing the cards on the motherboard. Moving the cards around can change the order in which the cards are configured by the system during power-on. This will go a long way toward resolving module conflicts.

Power-On Sequence for Advanced Configurations

As previously stated in [Chapter 2 Hardware Installation](#), it remains necessary to power up ALL Expansions Systems BEFORE you turn on the computer. This will ensure that your power-on software can read all available buses and properly configure all installed PCIe cards.

Obviously, the reverse also remains true for shutting your system down. The computer must be shut off BEFORE you attempt to turn off your Expansion System(s).

Troubleshooting Advanced Configurations

When trying to troubleshoot problems with PCIe cards in a multiple expansion system configurations, it is vital to correctly determine the nature of the problem. Therefore, the first task is to identify the card or chassis having a problem by using the Windows Device Manager, or Apple System Profiler. Refer to the first part of this Appendix for more information on identifying hierarchical levels in multiple expansion system configurations.

Problems with 3rd Party PCIe cards might only be traceable once you have identified the expansion system containing the problem card.

Below is a flow chart offering a troubleshooting approach when multiple expansion chasses are involved:

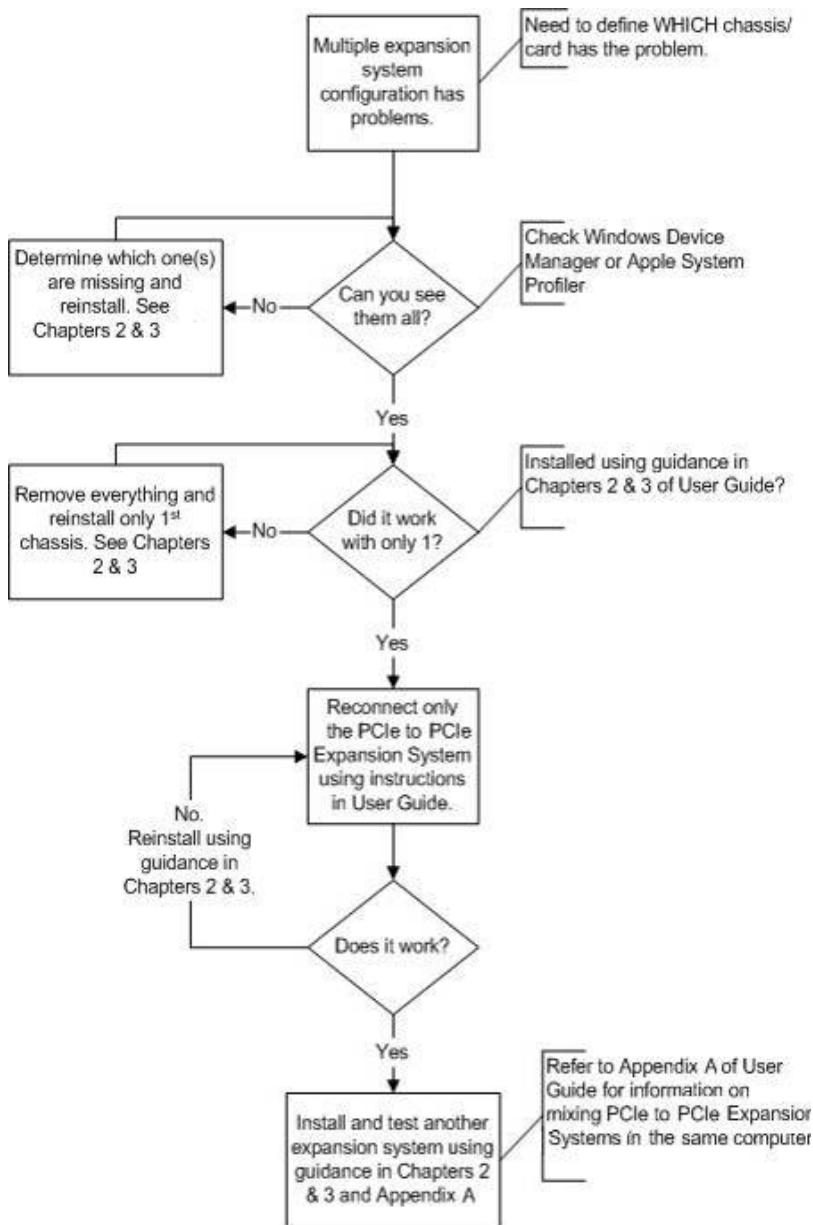

Finding the Problem Card

Windows

If you need help to determine which PCIe card, or which expansion chassis, has the problem, you can “right-click” on the card with the  and check the information contained in the “Location:” field.

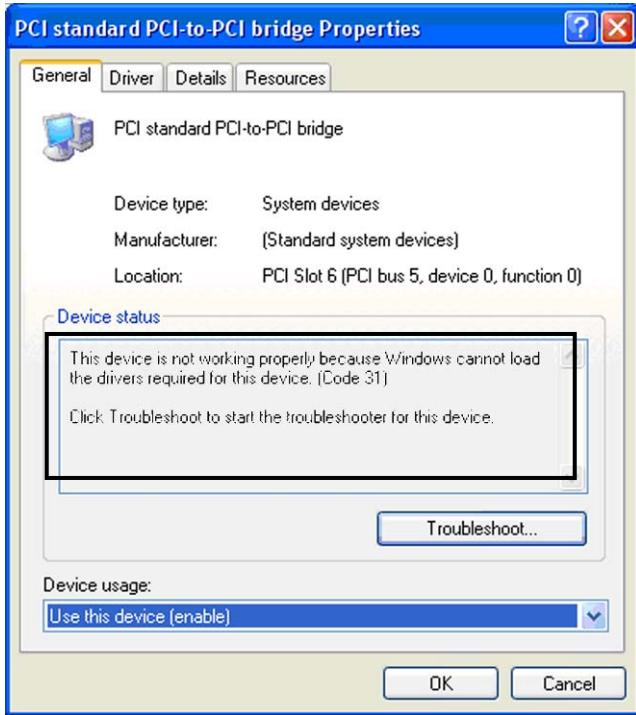

Look for the “Error Code” in the box in the center of the Properties Window and then go to the [Windows Error Code](#) section for information on how to resolve this issue.

MAC and Linux

If you have already reinstalled and reseated everything according to instructions in [Chapter 2](#), and the PCI to PCI Bridge is still not visible in the Apple System Profiler, call Magma Technical Support.

APPENDIX B Compliance

FCC

NOTE: This equipment has been tested and found to comply with the limits for a Class A digital device, pursuant to part 15 of the FCC Rules. These limits are designed to provide reasonable protection against harmful interference when the equipment is operated in a commercial environment. This equipment generates, uses, and can radiate radio frequency energy and, if not installed and used in accordance with the instruction manual, may cause harmful interference to radio communications. Operation of this equipment in a residential area is likely to cause harmful interference in which case the user will be required to correct the interference at his own expense.

This device complies with Part 15 of the FCC Rules. Operation is subject to the following two conditions: (1) this device may not cause harmful interference, and (2) this device must accept any interference received including interference that may cause undesired operation.

Changes or modifications not expressly approved by the party responsible for compliance could void the user's authority to operate the equipment.



NOTE

The assembler of a personal computer system may be required to test the system and/or make necessary modifications if a system is found to cause harmful interferences or to be noncompliant with the appropriate standards for its intended use.

Industry Canada

This Class A digital apparatus complies with Canadian ICES-003. Cet appareil numérique de la classe A est conforme à la norme NMB-003 du Canada



CE

The product(s) described in this manual complies with all applicable European Union (CE) directives. Magma will not retest or recertify systems or components that have been reconfigured by customers.



Magma

9918 Via Pasar, San Diego, CA 92126, USA

Phone (858) 530-2511 • Fax (858) 530-2733

www.magma.com

Manual P/N 09-09947-01-A

Free Manuals Download Website

<http://myh66.com>

<http://usermanuals.us>

<http://www.somanuals.com>

<http://www.4manuals.cc>

<http://www.manual-lib.com>

<http://www.404manual.com>

<http://www.luxmanual.com>

<http://aubethermostatmanual.com>

Golf course search by state

<http://golfingnear.com>

Email search by domain

<http://emailbydomain.com>

Auto manuals search

<http://auto.somanuals.com>

TV manuals search

<http://tv.somanuals.com>