

TECHNICAL INFORMATION



PRODUCT

P 1 / 26

Models No. ▶ LS0714, LS0714F, LS0714FL, LS0714L

Description ▶ Slide Compound Saw 190mm (7-1/2")

CONCEPT AND MAIN APPLICATIONS

New slide compound saw model LS0714 has been developed to improve cost-effectiveness by removing electronic circuit for soft start & constant speed from model LS0713.

The primary use is for making/modifying interior decorations in apartment building. Model LS0714's compact design and light weight are convenient to carry to workplace.

The LS0714 series is available in the following variations:

- *LS0714: With neither Fluorescent job light nor Laser marker
- *LS0714F: With Fluorescent job light for cutting workpiece in dark places
- *LS0714FL: With Fluorescent job light and Laser marker for easy trace of cutting line
- *LS0714L: With Laser marker

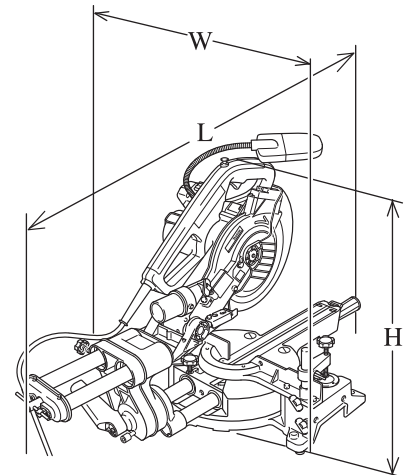

Dimensions : mm (")	
Length (L)	670 (26-3/8)
Width (W)	430 (17)
Height (H)	458 (18)

► Specification

Voltage (V)	Current (A)	Cycle (Hz)	Continuous Rating (W)		Max. Output(W)
			Input	Output	
110	9.7	50 / 60	1,010	450	1,200
120	10.0	50 / 60	—	500	1,200
220	4.8	50 / 60	1,010	450	1,200
230	4.6	50 / 60	1,010	450	1,200
240	4.4	50 / 60	1,010	450	1,200

Model No.	LS0714	LS0714F	LS0714FL	LS0714L
Saw blade	Diameter: mm (") 190 (7-1/2)			
	Hole diameter: mm (") 20 (13/16) [Canada, Chile, Colombia, Mexico, Panama, USA: 15.88 (5/8)]			
No load speed: min-1= rpm.	6,000			
Fluorescent job light	No	Yes	Yes	No
Laser marker	No	No	Yes	Yes
Lock-off botton for trigger switch	Yes			
Electric brake	No (for Canada and USA: Yes)			
Protection against electric shock	Double insulation			
Power supply cord: m (ft)	Australia 2.0 (6.6)			
	Except Australia 2.5 (8.2)			
Net weight: kg (lbs)	12.5 (27.6)	12.8 (28.2)	13.1 (28.9)	12.8 (28.2)

Cutting capacity: mm (")

Bevel angle		45° Left	90°	5° Right	
Miter angle	90°	With a 20mm auxiliary wood fence	45 x 265 (1-3/4 x 10-3/8)	60 x 265 (2-3/8 x 10-3/8)	—
		—	40 x 300 (1-9/16 x 11-3/4)	52 x 300 (2-1/16 x 11-3/4)	40 x 300 (1-9/16 x 11-3/4)
	45° Left and Right	With a 15mm auxiliary wood fence	45 x 185 (1-3/4 x 7-1/4)	60 x 185 (2-3/8 x 7-1/4)	—
		—	40 x 212 (1-9/16 x 8-3/8)	52 x 212 (2-1/16 x 8-3/8)	—
	57° Right	With a 10mm auxiliary wood fence	—	60 x 145 (2-3/8 x 5-3/4)	—
		—	—	52 x 163 (2-1/16 x 6-3/8)	—

► **Standard equipment**

T.C.T. Saw blade 190mm	1 pc	Holder set (2 pcs. in set)	1 set
Socket wrench 10	1 pc	Triangular rule	1 pc
Dust bag	1 pc	Hex wrench 2.5 (LS0714FL/ LS0714L only).....	1 pc
Vertical vise	1 pc	Switch button	2 pcs

Note: The standard equipment for the tool shown may differ from country to country.

► **Optional accessories**

Horizontal vise	Set plate assembly	Holder assembly for supporting long stock
Holder assembly	Various TCT saw blades	Fluorescent tube for LS0714F and LS0714FL

► Repair

WARNING: Be sure to unplug the tool before maintenance or repair.

See the instruction manual on how to handle the tool.

Remove the following parts from the machine for safety before repair/ maintenance:

***Saw Blade *Inner Flange *Outer Flange *Dust Nozzle**

[1] Lubrication

1. Apply Makita grease N. No.1 to the following portions designated by black triangle to protect parts and product from unusual abrasion. See Fig. 1.

Item No.	Parts description	Portion to lubricate
16	Blade case	Apply 6g to the gear room if the room has been washed for cleaning. Both pivot portions where front arm (item No. 145) contacts
136	Arm complete	Inside of hole which accepts arm holder's (156) rib portion. Linear ball bearing in which pipe portion of front arm (145) slides
139	Stopper plate	Surface to which inner wall of arm holder (156) contacts
145	Front arm complete	Pivot portion where blade case (16) contacts
153	O ring 5	Whole
155	Pipe 16-90	Pipe ends to which axis holes of front arm complete (145) contact
156	Arm holder	Swivel portion where arm complete (136) contacts
158	Screw M10	Threads
159, 161	Flat washer 10	Surfaces where thrust needle gauge 1024 (160) contacts
160	Thrust needle gauge 1024	Head and reverse side to which washers 10 (159 and 161) contact

Fig. 1

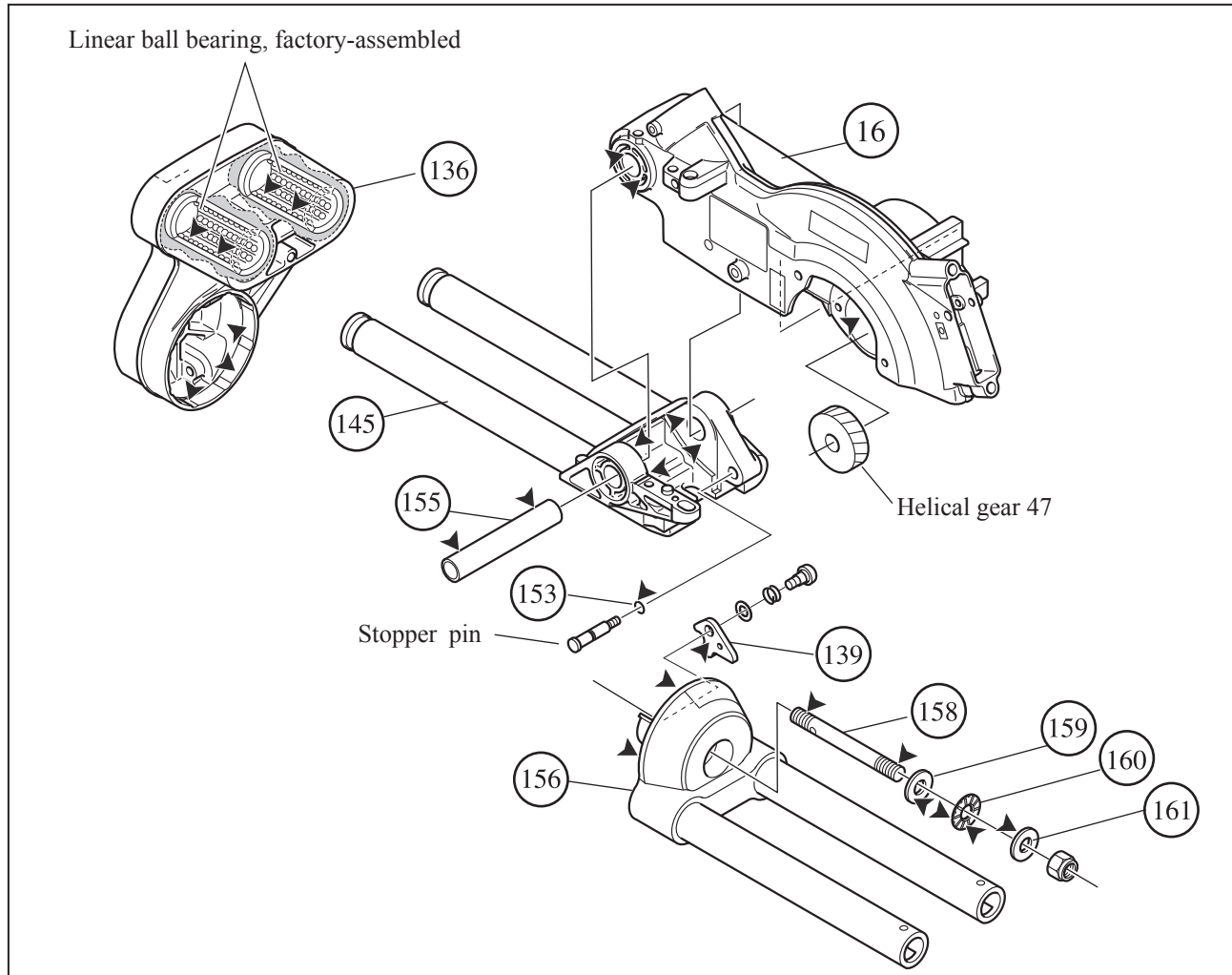

► Repair

2. Apply Makita grease N. No.1 to the following portions designated by black triangle to protect parts and product from unusual abrasion. See **Fig. 2**.

Item No.	Parts item	Portion to lubricate
17	Spiral spring 26	Whole
21	Center plate	Portion where center cover contacts
27	Link plate	Tip round portion
173	Turn base	Axis
		Linear ball bearing in which arm holder's (156) pipe slides
190	Grip 32	Threads
194	Base	The boss for accepting (173) turn base's axis
195, 196	Slide plate	The surface on which (173) turn base's edge slides

Fig. 2

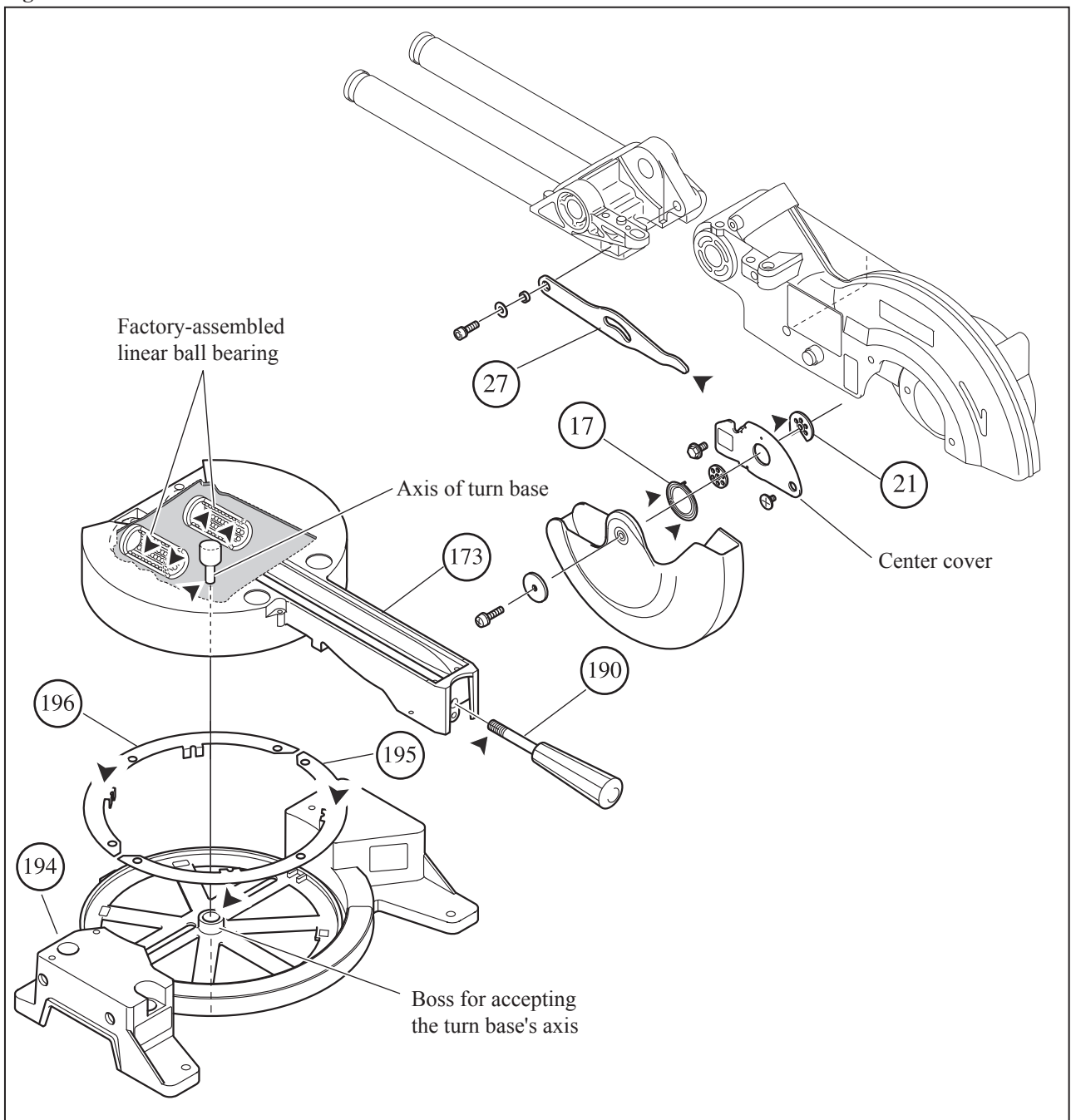

► **Repair**

[2] Removing motor unit (blade case, motor housing, handle etc.) from front arm complete

1. Remove safety cover section from blade case as illustrated in **Fig. 3-1**, **Fig.3-2** and **Fig.3-3**.

Fig. 3-1

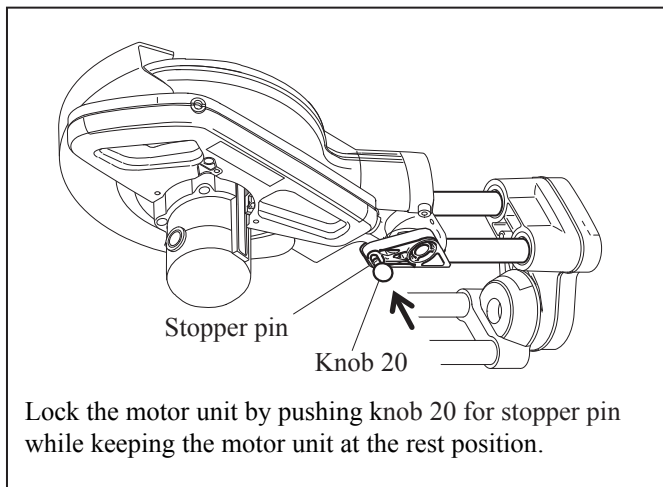

Fig. 3-2

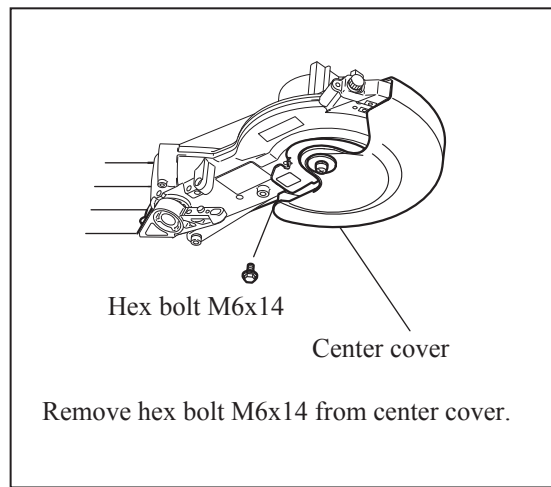
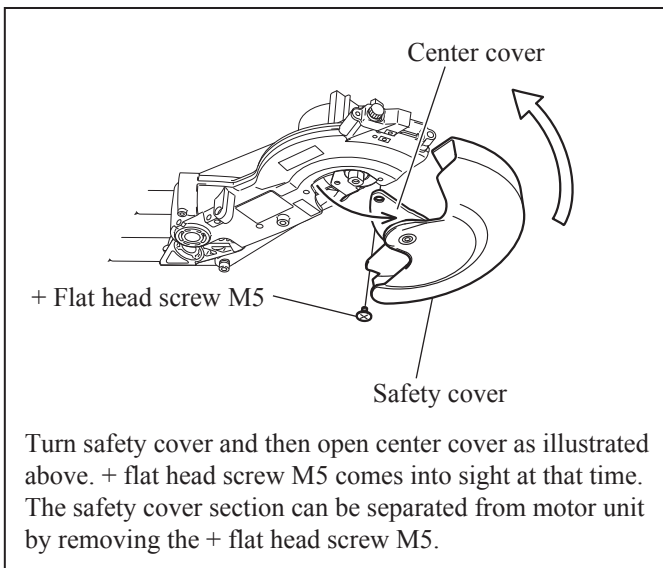
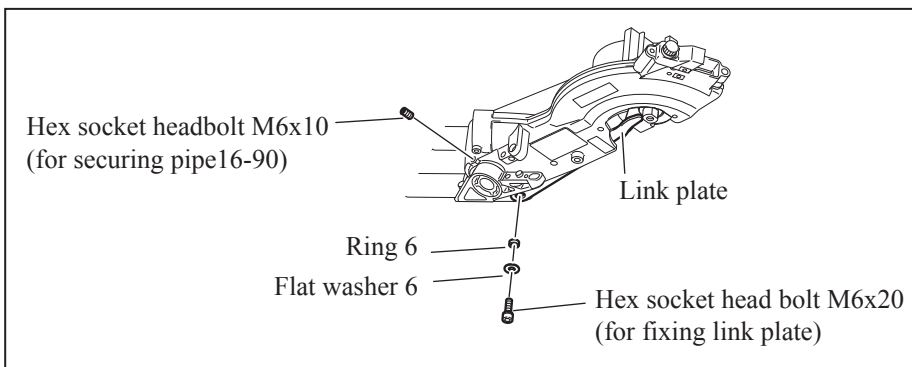

Fig. 3-3



2. Remove the screws in **Fig. 3-4** to disconnect the linkage of motor unit and front arm complete.

Fig. 3-4



► Repair

3. While holding the motor unit with your hand, pull out knob 20 for stopper pin to release the lock of motor unit, and lift up the motor unit slowly until it comes to the free point from return force of torsion spring 28. See **Fig. 3-5**.
4. Remove pipe 16-90 by pushing it out using socket wrench 10. See **Fig. 3-6**.
5. Remove motor unit from front arm complete. See **Fig. 3-7**.

Fig. 3-5

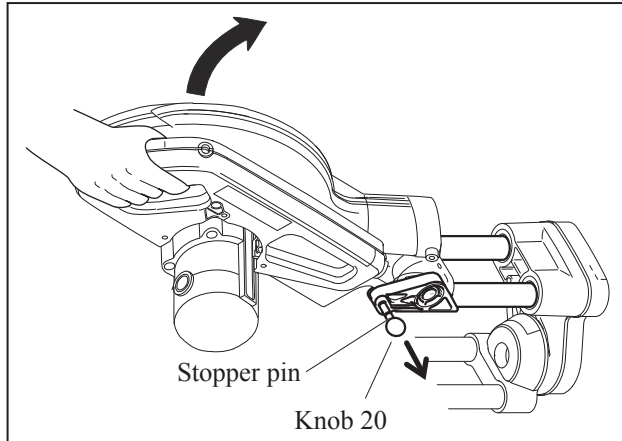

Fig. 3-6

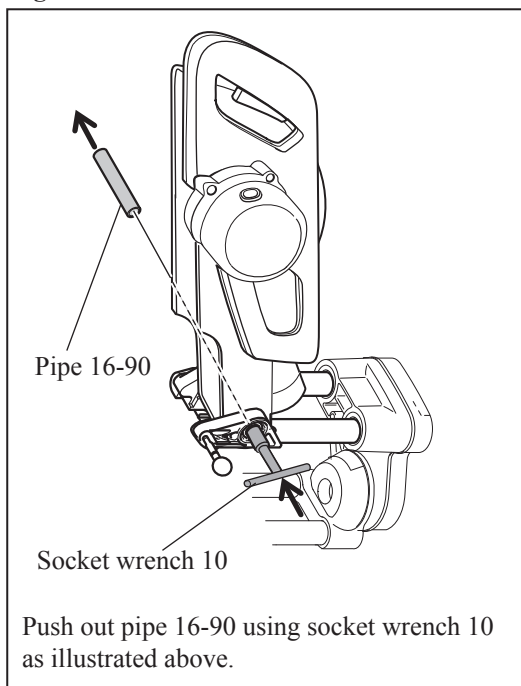
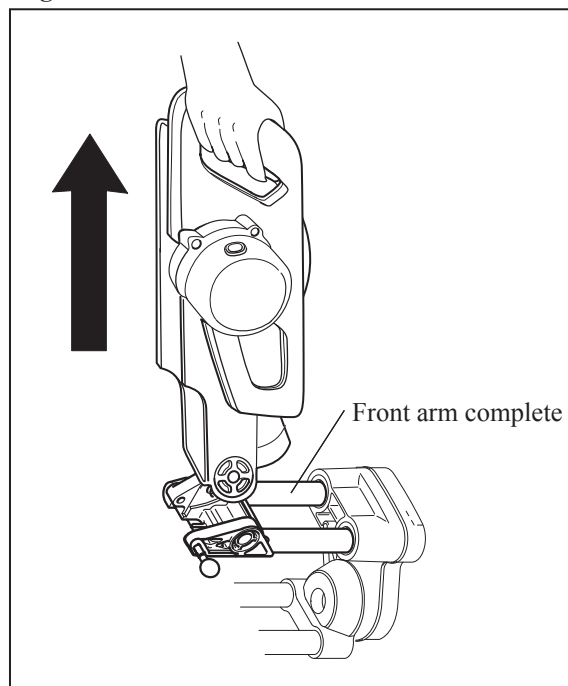

Fig. 3-7



[3] Mounting motor unit (blade case, motor housing, handle etc.) to front arm complete

1. Insert two sleeves 17 into torsion spring 28. See **Fig. 4**.
2. Mount the motor unit to front arm complete. Refer to **Fig. 3-7**.
3. Pass pipe 16-90 through the holes of front arm and blade case. Refer to **Fig. 3-6**.
4. While keeping motor unit in the rest position, push knob 20 for stopper pin toward the blade case side. Refer to **Fig. 3-5**.
5. Secure link plate with hex socket head bolt M6x20, and secure the pipe 16-90 with ring 6, flat washer 6 and hex socket head screw M6x10. Refer to **Fig. 3-4**.

Fig. 4

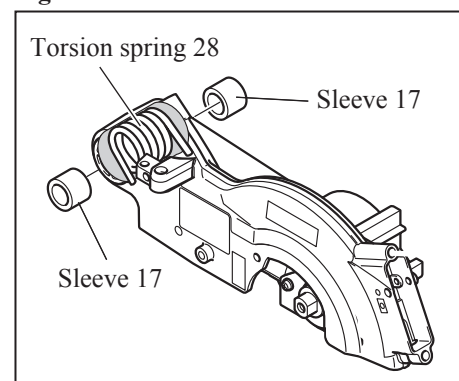

► Repair

[5] Adjusting the return force of torsion spring 28

1. Torsion spring 28 should be adjusted so that motor unit can smoothly return to the initial raised position from any other place.

Turning hex socket head set screw M6x16 with hex wrench allows to adjust the return force. See **Fig. 5**.

Fig. 5

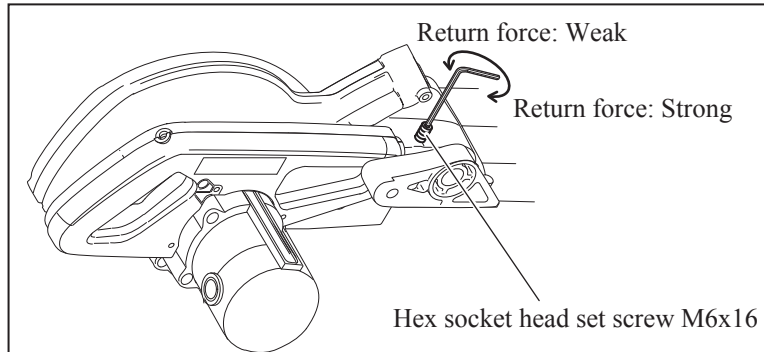

[6] Assembling safety lock mechanism

Note: The products for the following countries are equipped with safety lock mechanism.

* Europe * South Africa * China

1. Assemble the component parts of safety lock mechanism as illustrated in **Fig. 6-1**.
2. Holding the mounted compression spring 7 to lock lever, pass the lock lever through the loop portion of handle, and bring the safety lock mechanism between handle and blade case complete. See **Fig. 6-2**.
3. Pass lock pin through the large hole of lock plate. And lift up lock plate in order to align its screw holes with those of rod 8. Then, the lock pin's head comes to the keyhole slot of lock plate. And secure lock plate with pan head screw M4x10 to rod 8. See **Fig. 6-3**.
4. Secure rod holder with tapping screw bind CT 4x16, while pressing it toward blade case complete in order to make rod 8 parallel to handle as **Fig. 6-4**. Make sure that safety cover is locked with safety lock mechanism when lock lever is in the original position.

Fig. 6-1

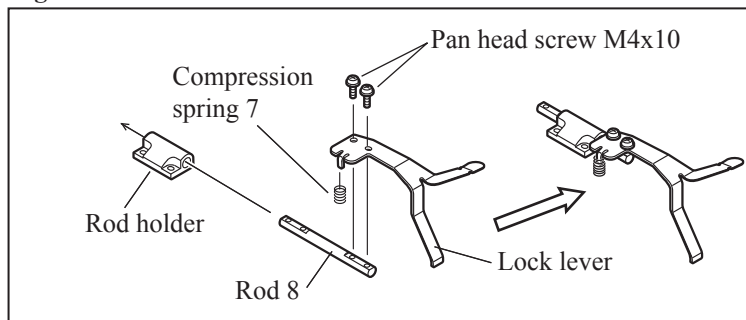

Fig. 6-2

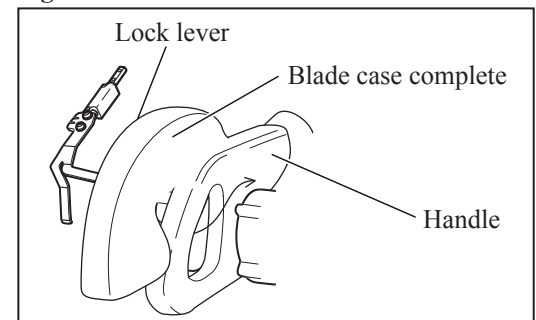

Fig. 6-3

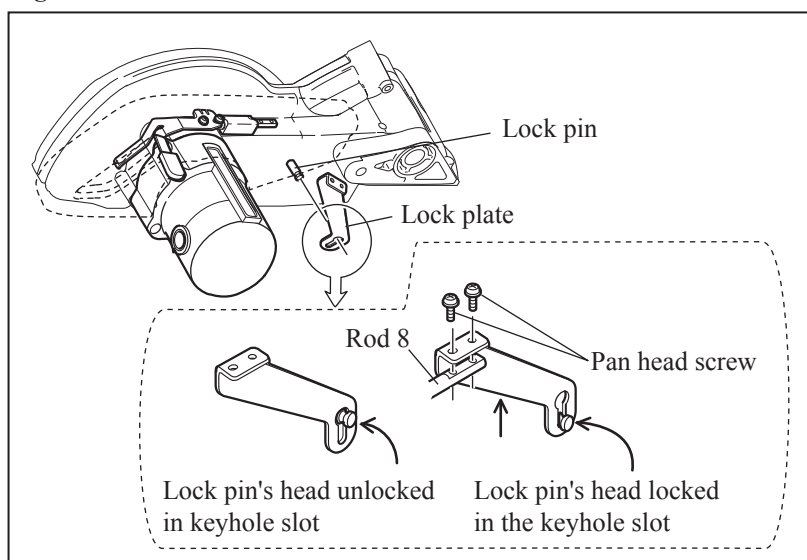
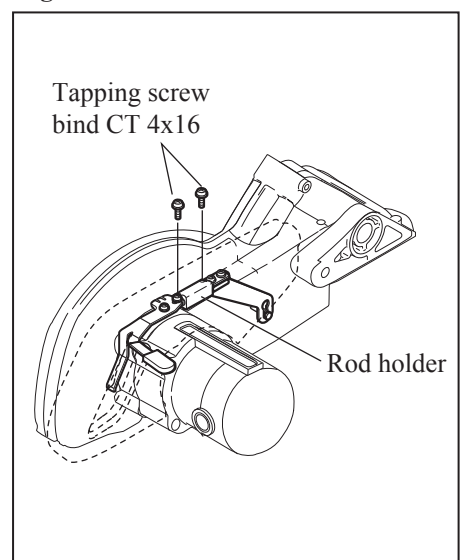

Fig. 6-4



► Repair

[7] Assembling safety cover section

1. Insert the tail portion of spiral spring 26 into the elliptical hole of safety cover. See **Fig. 7-1**.
2. Mount center washer to safety cover by aligning its holes with four bosses of safety cover. See **Fig. 7-2**.
3. Mount center cover by inserting the another tail portion of spiral spring 26 into the center cover's hole. See **Fig. 7-3**.
4. Mount center plate to safety cover by fitting four bosses of safety cover into center plate's holes. See **Fig. 7-4**.
5. Fix the assembled parts with pan head screw M5x18. See **Fig. 7-5**.

Fig. 7-1

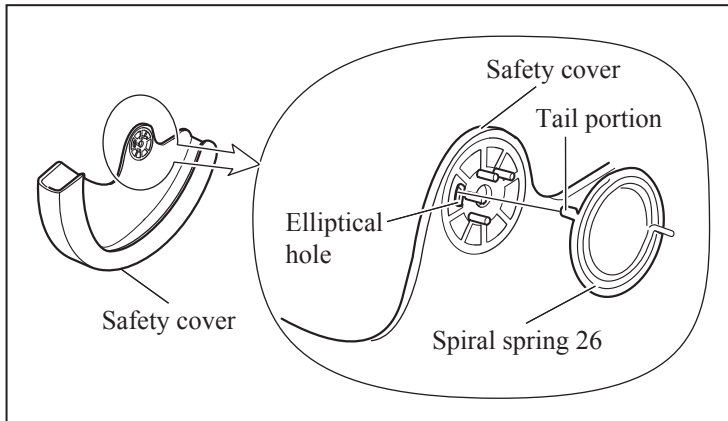

Fig. 7-2

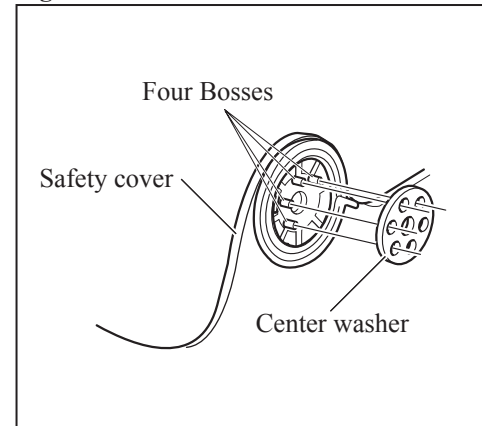

Fig. 7-3

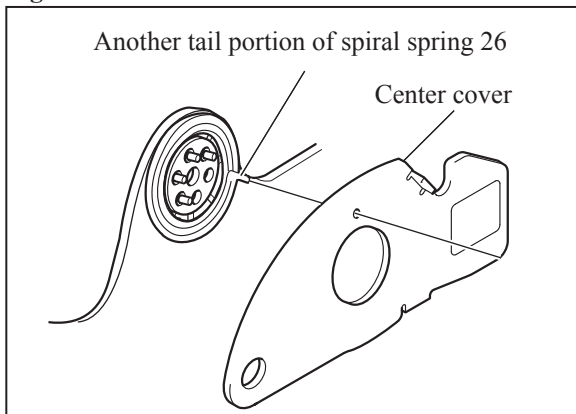

Fig. 7-4

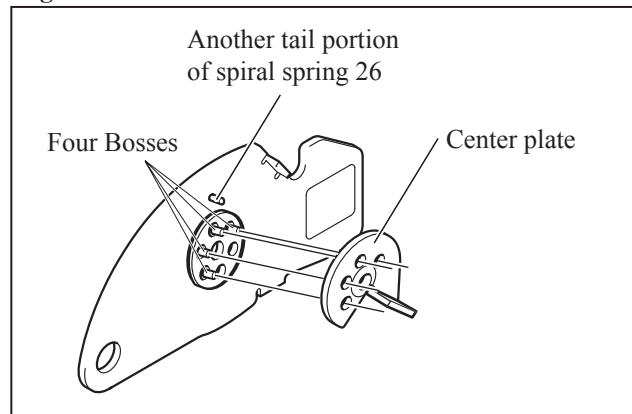
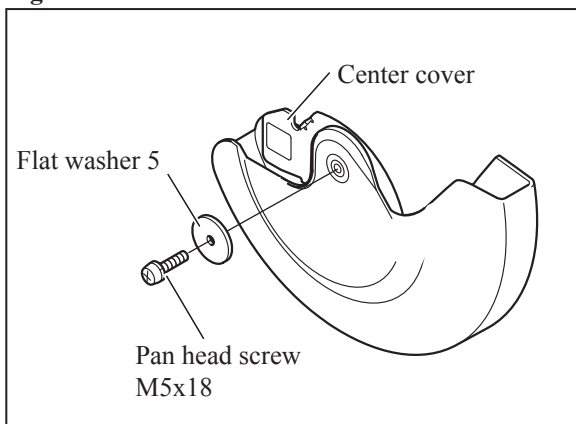

Fig. 7-5



► **Repair**

[8] Removing turn base from base

1. Remove guide fence and kerf board. See **Fig. 8-1**.
2. Remove hex lock nut M8-13 using socket wrench. And then, remove turn base from base while pushing lock lever in the direction designated with arrow. See **Fig. 8-2**.

Fig. 8-1

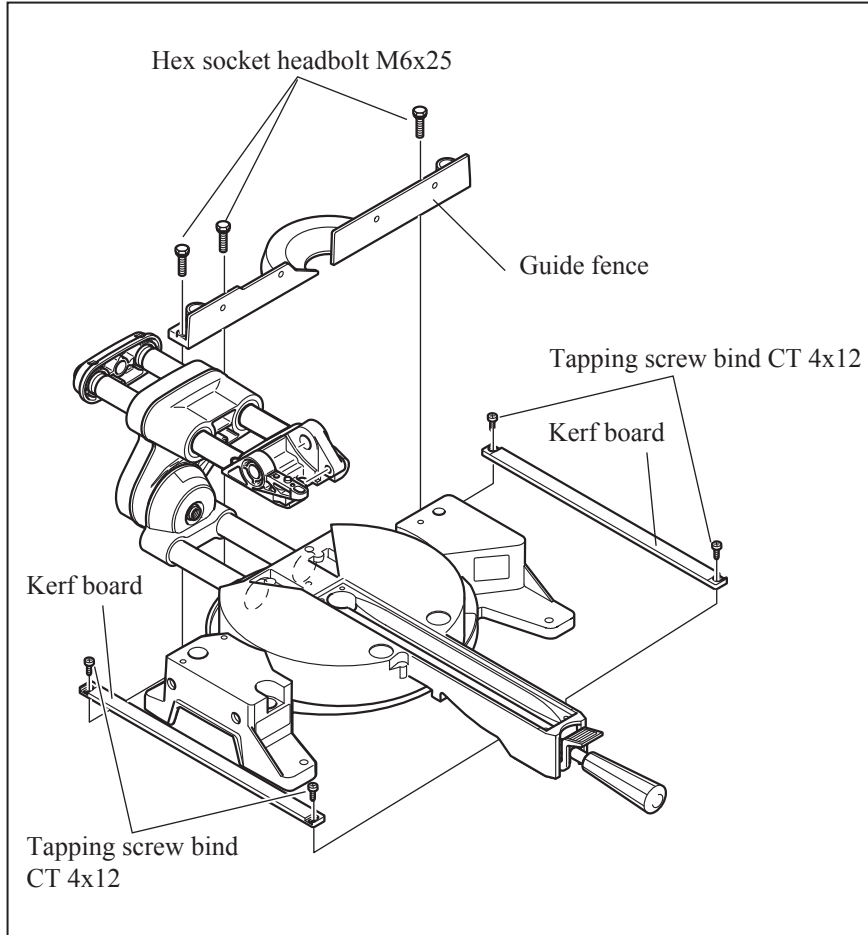
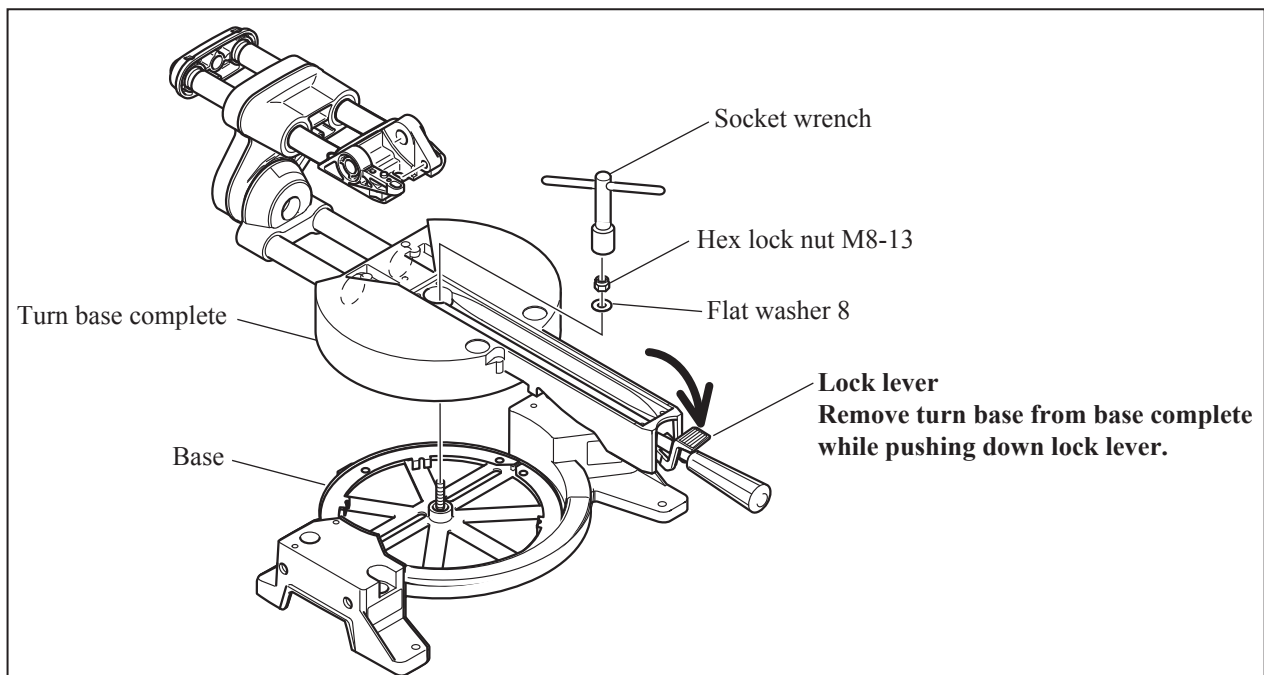

Fig. 8-2



► Repair

[9] Mounting turn base to base

1. Apply grease to slide plate and boss for accepting the turn base's axis. Refer to **Fig. 2**.
2. Fasten hex lock nut M8-13 so that the turn base can move smoothly without wobbling. Refer to **Fig. 8-2**.

[10] Mounting square rod and securing ring 26

1. Setting ring 26 to pipe 25-235 of arm holder complete, mount arm holder complete to turn base. See **Fig. 9-1**.
2. Slide arm holder complete so that each end of the two pipes come nearer to the axis of turn base. See **Fig. 9-2**.
3. Secure square rod to pipes of arm holder complete with hex bolt M5x30.

Fig. 9-1

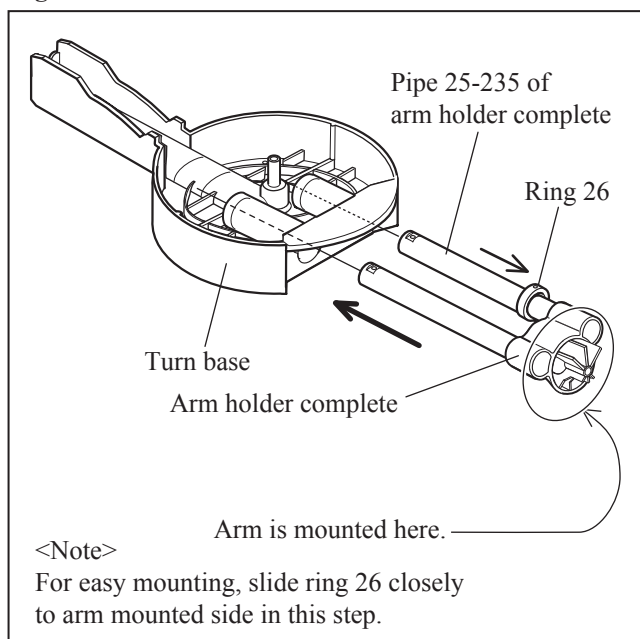
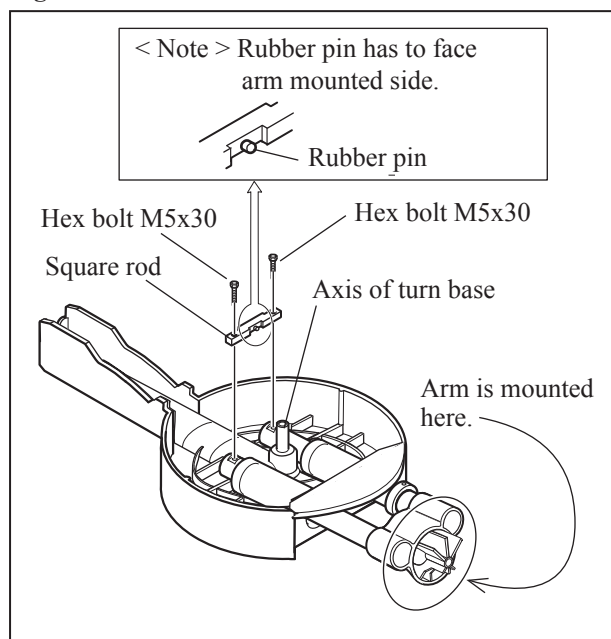
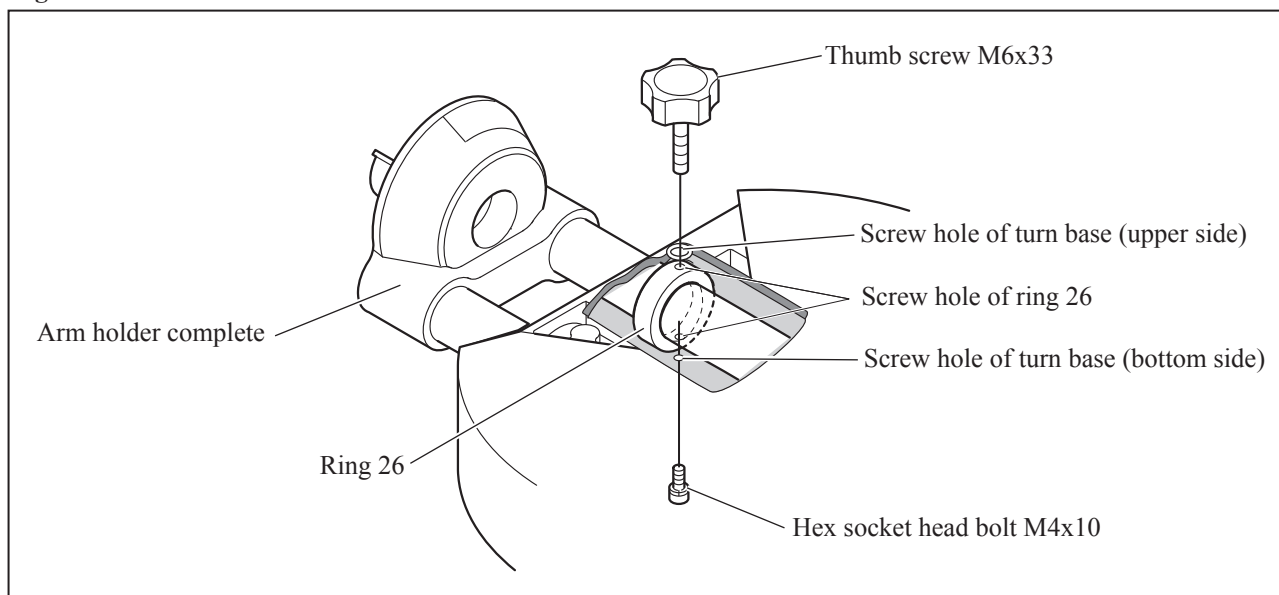

Fig. 9-2



4. Slide ring 26 toward turn base and align the following holes for thumb screw M6x33 and hex socket head bolt M4x10.
 - * Screw hole of turn base (upper side)
 - * Screw holes of ring 26
 - * Screw hole of turn base (bottom side)
 And tighten thumb screw M6x33 to secure ring 26 to turn base. See **Fig. 9-3**.
5. Tighten hex socket head bolt M4x10 from the bottom side of turn base. Then ring 26 is completely secured to turn base.

Fig. 9-3



► **Repair**

[11] Disassembling positive lock mechanism of turn base

1. Remove grip 32.
2. Separate lock lever plate and lock lever from turn base by removing tapping screw bind CT 4x16. See **Fig. 10-1**.
3. Turn lock pin in order to face pin 3 to vertical direction. And remove pin 3 while pushing compression spring 6 toward the grip side. See **Fig. 10-2**.
4. By pulling off lock pin from turn base, compression spring 6 can be removed from lock pin.

Fig. 10-1

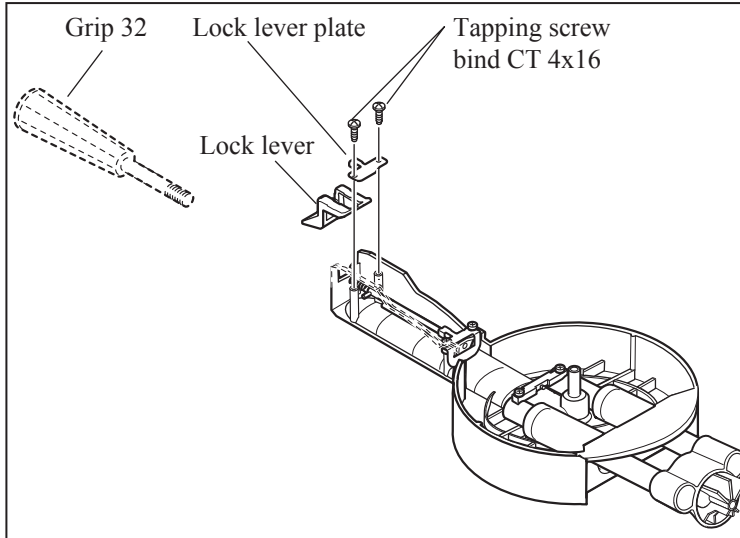
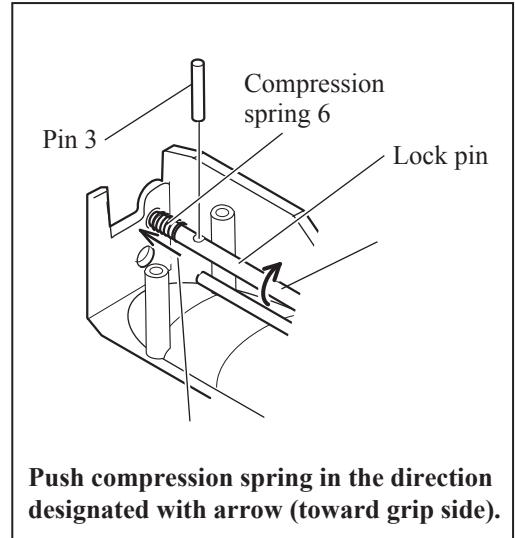

Fig. 10-2



[12] Assembling positive lock mechanism of turn base

Do the reverse of disassembling procedure with the following attention:

1. The protrusion of lock lever plate has to face the grip side.
2. Apply grease to the threaded portion of the grip.
See **Fig. 11**.

Fig. 11

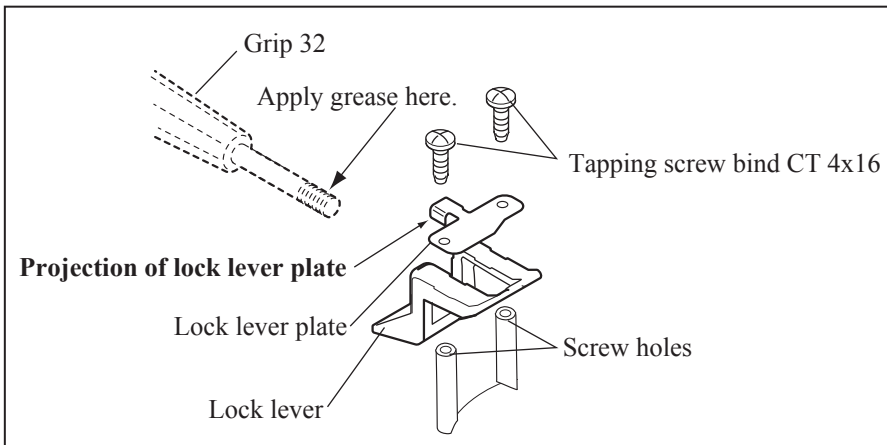

► Repair

[13] Mounting stopper plate to arm holder

Mount stopper plate as illustrated in Fig. 12.

Fig. 12

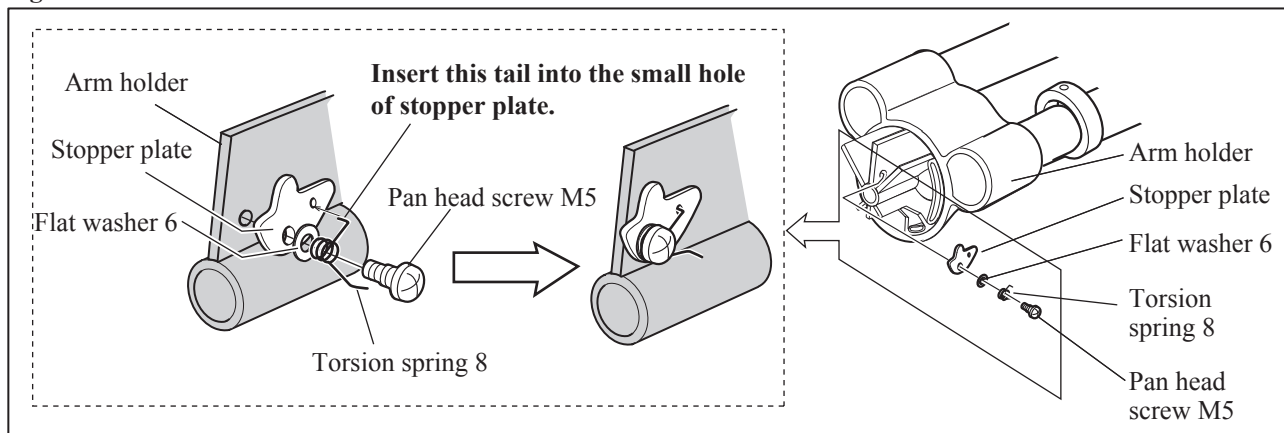

[14] Mounting ring 26 and set screw M4x8

1. Insert ring 26 into the hole of arm. See Fig. 13.
2. Drive set screw M4x8 into the screw hole of arm by screwing thumb screw M6x33 with hex wrench. Stop driving the set screw at the same time it reaches surface A.

Fig. 13

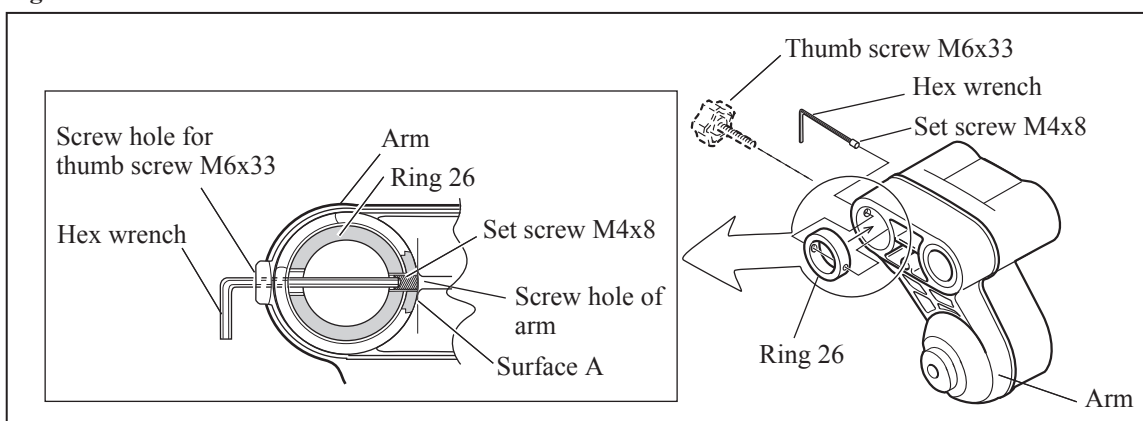

[15] Adjusting arm for smooth pivot action

1. Adjust hex lock nut M10x17 so that arm can pivot smooth without backlash. See Fig. 14-1.
2. Mount lever 100 and the relevant parts to arm with keeping the lever angle in lock position as Fig. 14-2.

Fig. 14-1

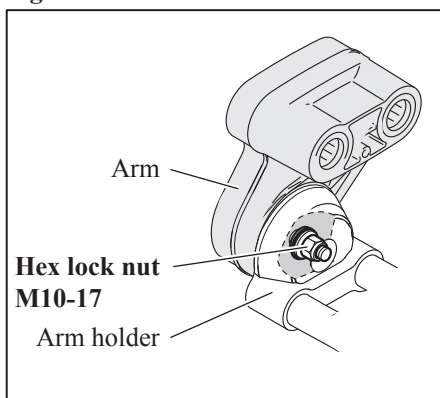
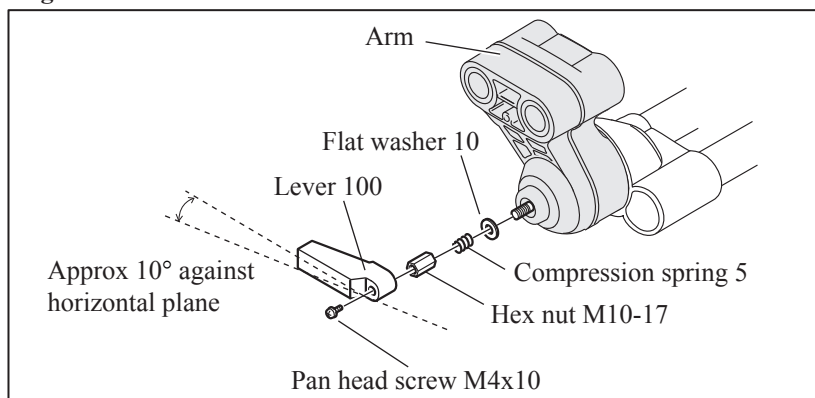

Fig. 14-2



► Repair

[16] Angle adjustment of saw blade

1. Adjust the angle of saw blade at 90° against turn base using 90 degrees set square (Makita Part No.1R208). See **Fig. 15-1**.
While keeping this condition, fix the angle by adjusting 0° degrees bevel angle adjusting bolt at the side of arm. See **Fig. 15-2**.
2. As for 45° degrees adjusting, use 45 degrees set square as **Fig. 15-3**.
After that the fix the angle by adjusting 0° degrees bevel angle adjusting bolt at the side of arm as **Fig. 15-4**.

Fig. 15-1

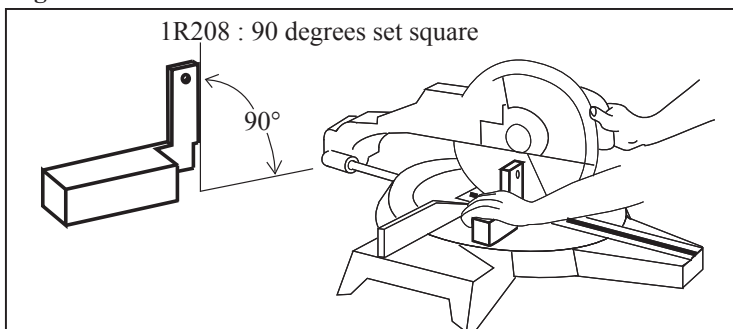

Fig. 15-2

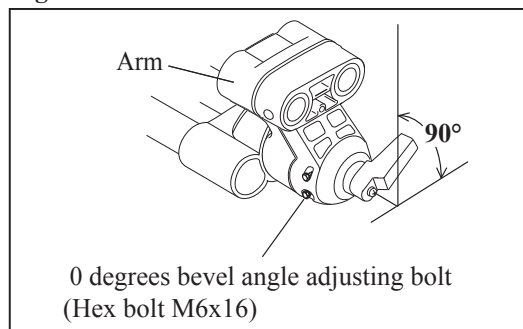

Fig. 15-3

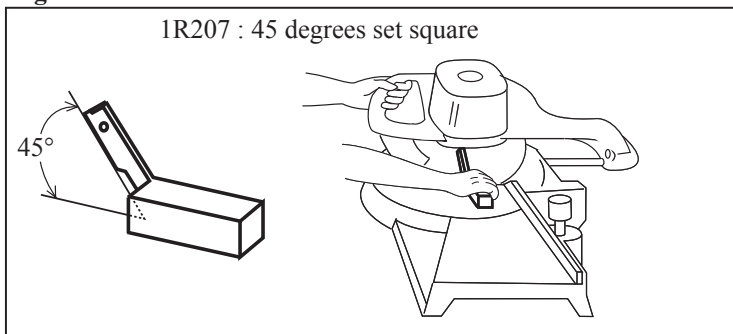
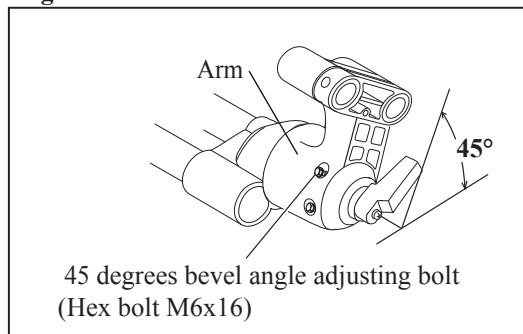

Fig. 15-4



[17] Adjustment for max. cutting capacity

Do the following steps to obtain the max. cutting capacity.

1. Pull the motor unit to your side until it stops.
2. Lower the motor unit until it stops.
3. And then adjust the $\varnothing 190\text{mm}$ saw blade so that it comes to the position shown in **Fig. 16**.

Note: The saw blade must not contact kerf boards and base, when the motor unit is in the lowest position.

4. Tighten hex bolt M6x16 using socket wrench 10.

Fig. 16

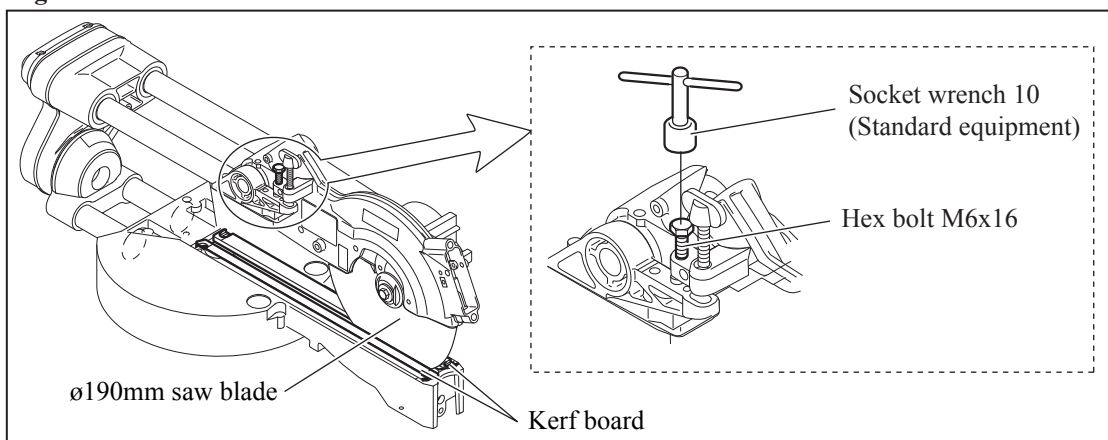

► Repair

[18] Angle adjustment of guide fence

1. Provisionally tighten a M6x25 hex bolt into screw hole A on the operator's left side of guide fence as **Fig. 17**.
2. While checking the angle of guide rule to saw blade using 90 degrees set square (No.1R208), adjust the guide fence by moving its right end until the angle sets at 90 degrees.
3. After completion of squaring adjustment, securely tighten three M6x25 hex bolts in order of C, B, A.

Fig. 17

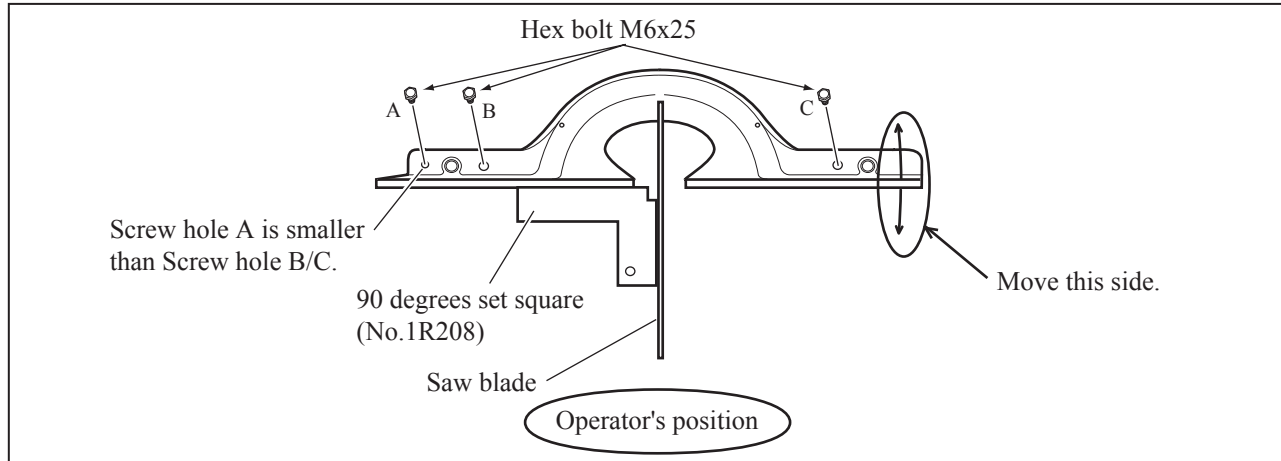

[19] Disassembling laser section (exclusively for LS0714FL/ LS0714L)

1. Remove lock lever from rod 8 before disassembling laser section.
Refer to the chapter < 6 > "Assembling safety lock mechanism".
2. After removing thumb screw M5x24, remove top cover by taking off tapping screw bind CT4x20. See **Fig. 18-1**.
3. Take off laser line label which adheres on blade case, and remove shoulder screw M5 with which laser section is secured on blade case.

Fig. 18-1

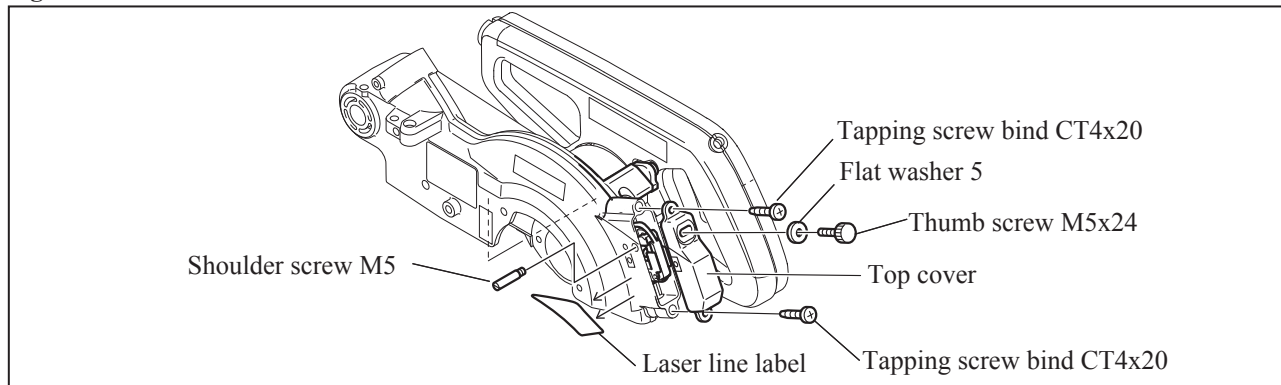

4. Remove lead cover holder by unscrewing tapping screw bind CT4x20. Then, lead cover A and lead cover B can be removed from blade case. See **Fig. 18-2**.
5. Disconnect socket unit of laser circuit from connector of lead unit.
6. Then, laser section can be removed from blade case.

Fig. 18-2

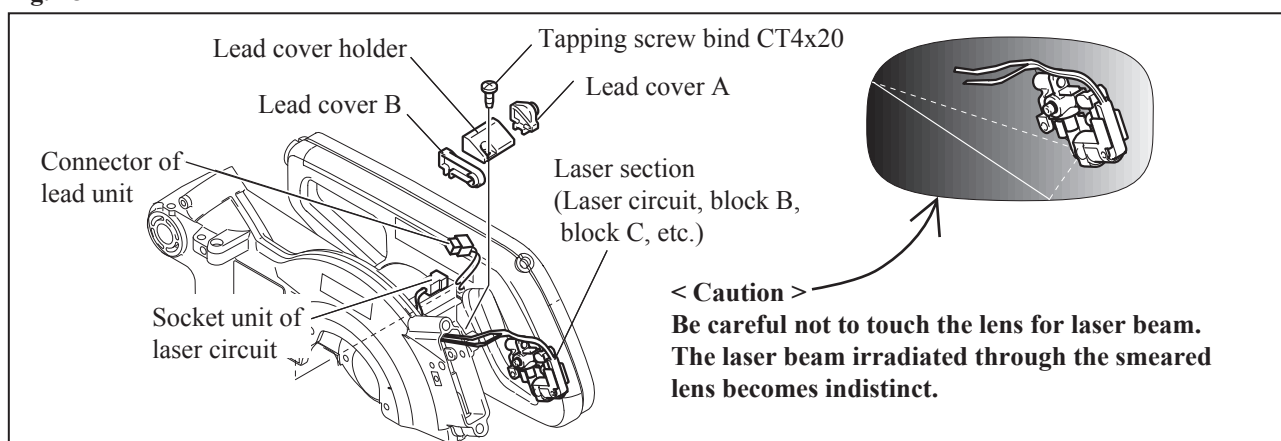

► Repair

7. Laser section can be disassembled as shown in **Fig. 18-3**.

Fig. 18-3

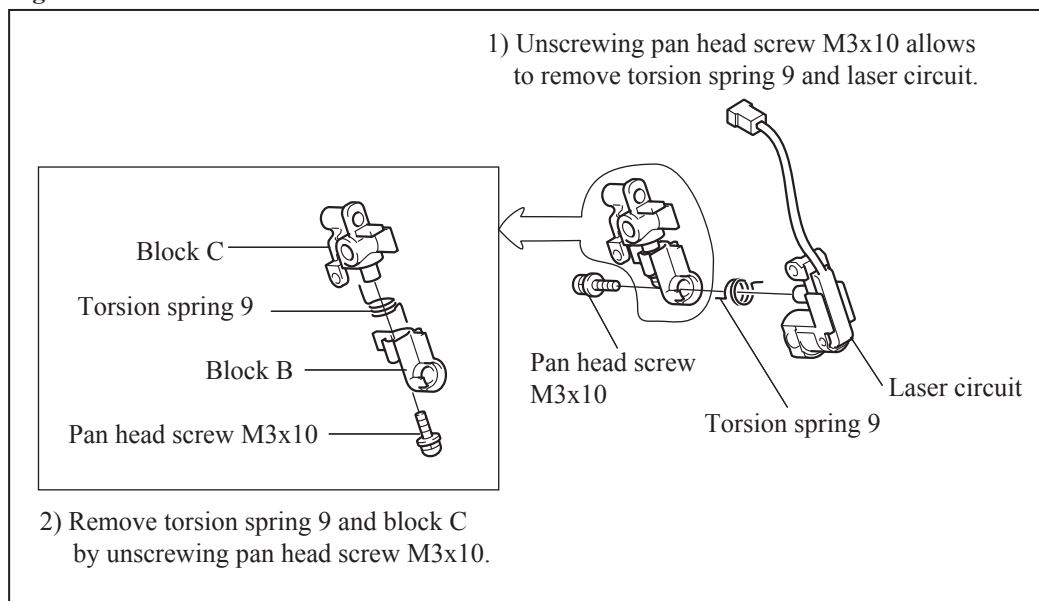

[20] Assembling laser section (exclusively for LS0714FL/ LS0714L)

1. Mount torsion spring 9 and block B to block C and secure them with pan head screw M3x10. Refer to **Fig. 19-1**.
Make sure that block C and block B can move in torsional direction.
2. Mount torsion spring 9 and laser circuit to block B, and secure them with pan head screw M3x10. Refer to **Fig. 18-3**.
Make sure that block B and laser circuit can move in torsional direction. See **Fig. 19-2**.

Fig. 19-1

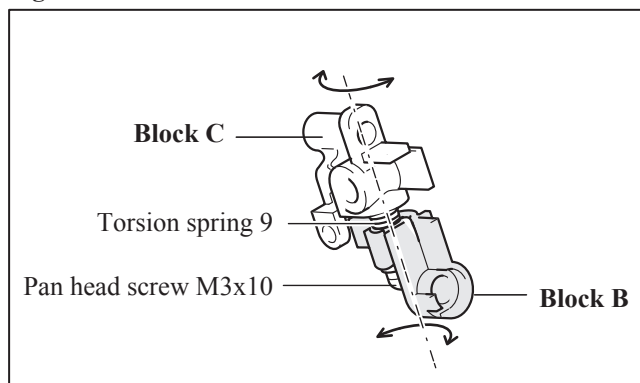
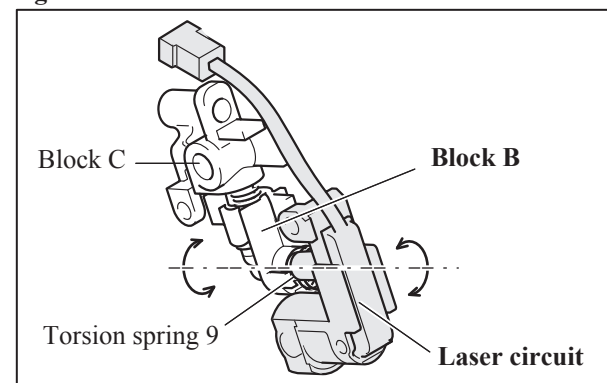

Fig. 19-2



3. For easy adjustment of irradiated angle of laser beam from now on, drive hex socket set screws M4x6 until their head portions come to the same level with the surfaces of block C and laser circuit. See **Fig. 19-3**.
4. Hold the lead wires of laser circuit between two ribs of block C. See **Fig. 19-4**.

Fig. 19-3

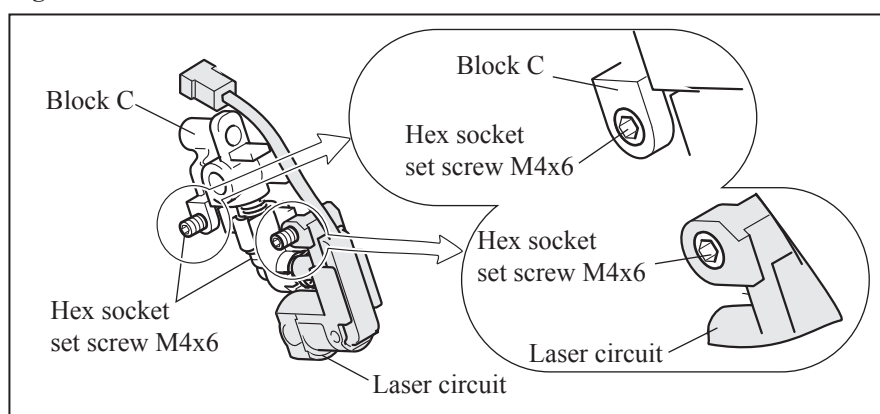
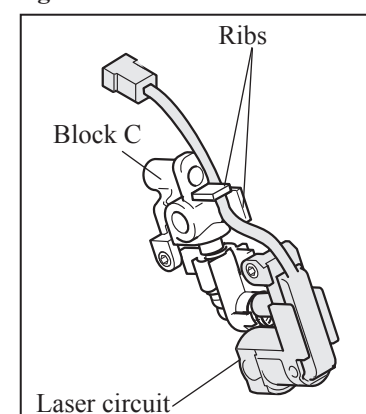

Fig. 19-4



► Repair

WARNING: Special attention should be taken to the adjustment because plugging the tool is required. Don't turn on the main switch for cutting operation of the tool while adjusting the laser line position. Turn on the switch of laser beam only. Never look into the laser beam. Direct laser beam may injure your eyes.

(1) Mechanism for adjustment of the position of laser line

1. Adjustment of the position of laser line can be made with the following screws which are under laser line label.

* Hex socket set screw M4x6 (A): for adjusting 90° to turn base See **Fig.20-A**

* Hex socket set screw M4x6 (B): for adjusting 90° to guide fence See **Fig. 20-B**

Fig. 20-1

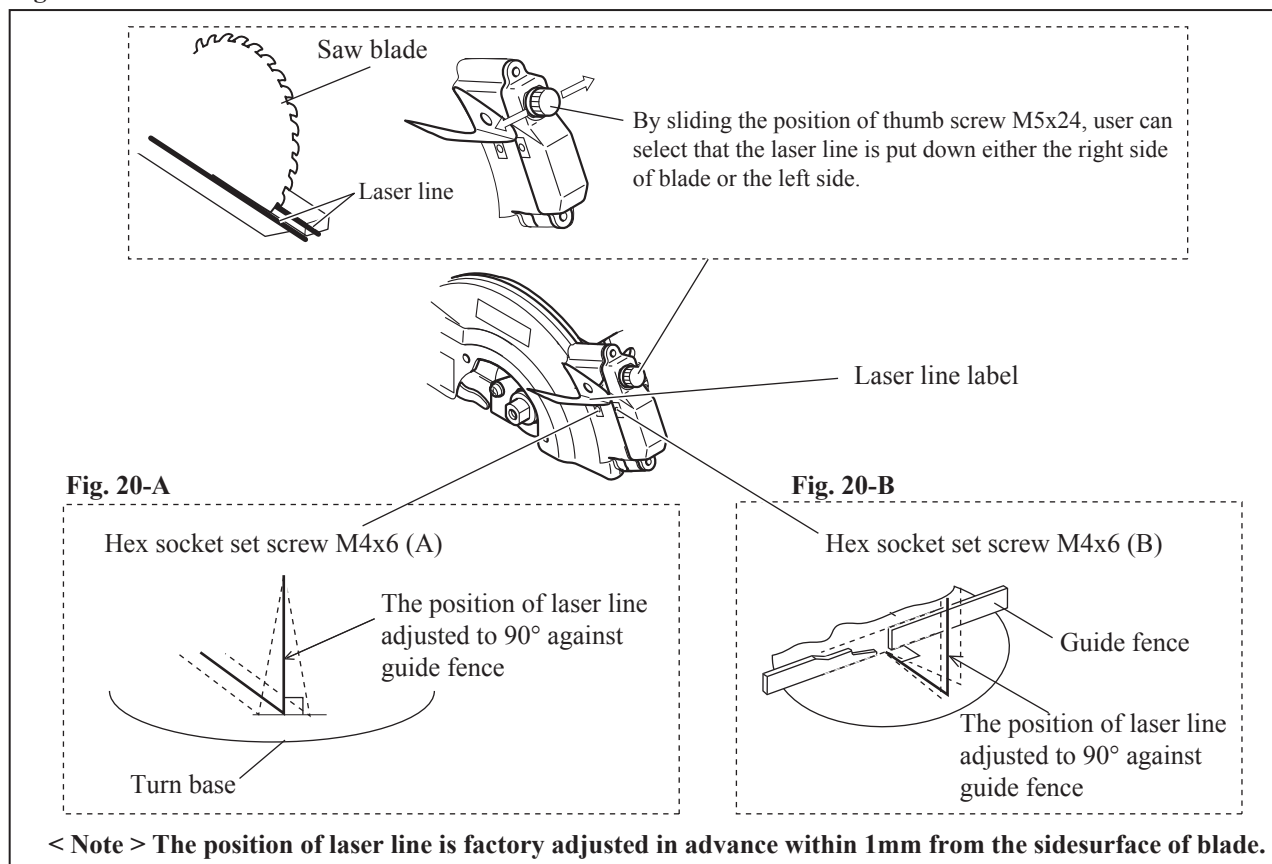

(2) Precise adjustment of laser line

1. Lock the motor unit at the initial position. Mount "Jig for laser line adjustment" (Makita part No. 1R315) to spindle and drive hex bolt M6x18 into the screw hole of spindle head. See **Fig. 20-2**.

Fig. 20-2

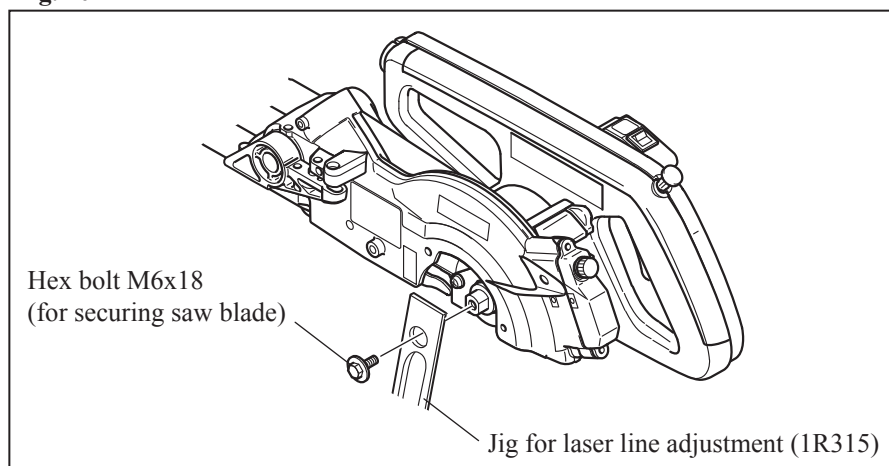

► Repair

2. Make precise adjustment so that the laser line should be aligned with the line of jig for laser line adjustment (1R315) when lowering the jig until it reaches the pan head screw M5x16 of link plate side. See **Fig. 20-3**.

Fig. 20-3

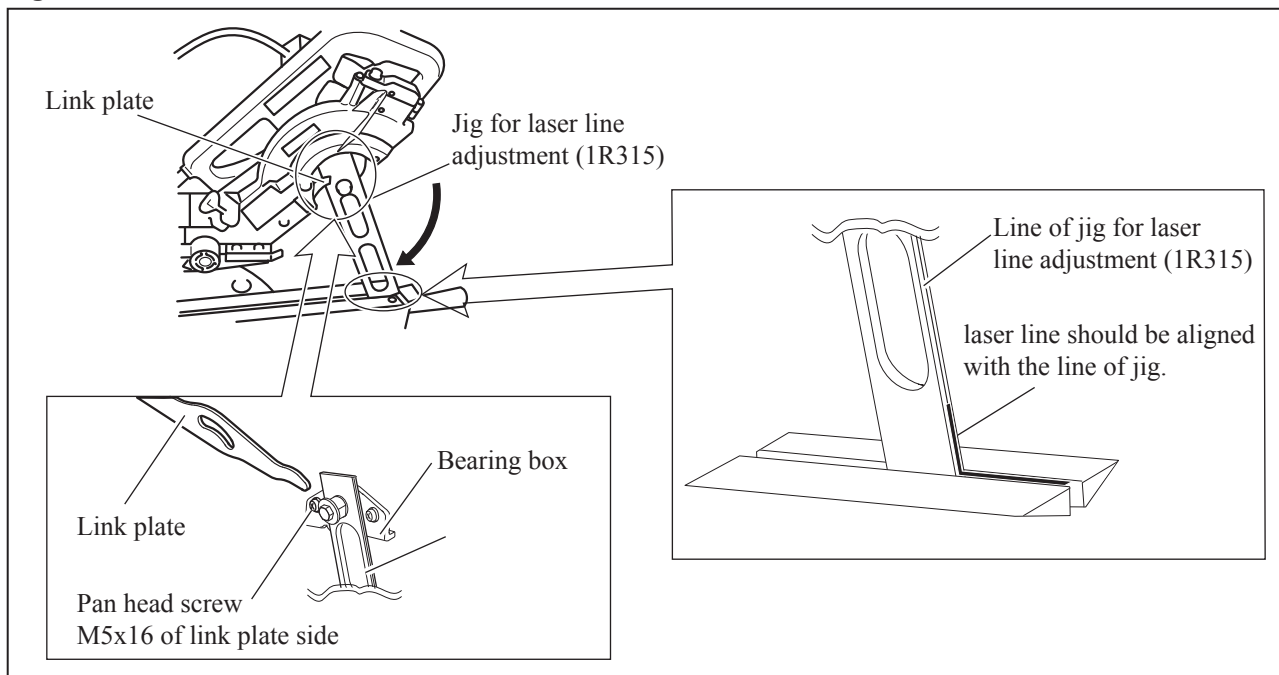

3. When lifting up the jig for laser line adjustment (1R315) until it reaches the pan head screw M5x16 of the laser box side, be sure to make precise adjustment as **Fig. 20-4**.

Fig. 20-4

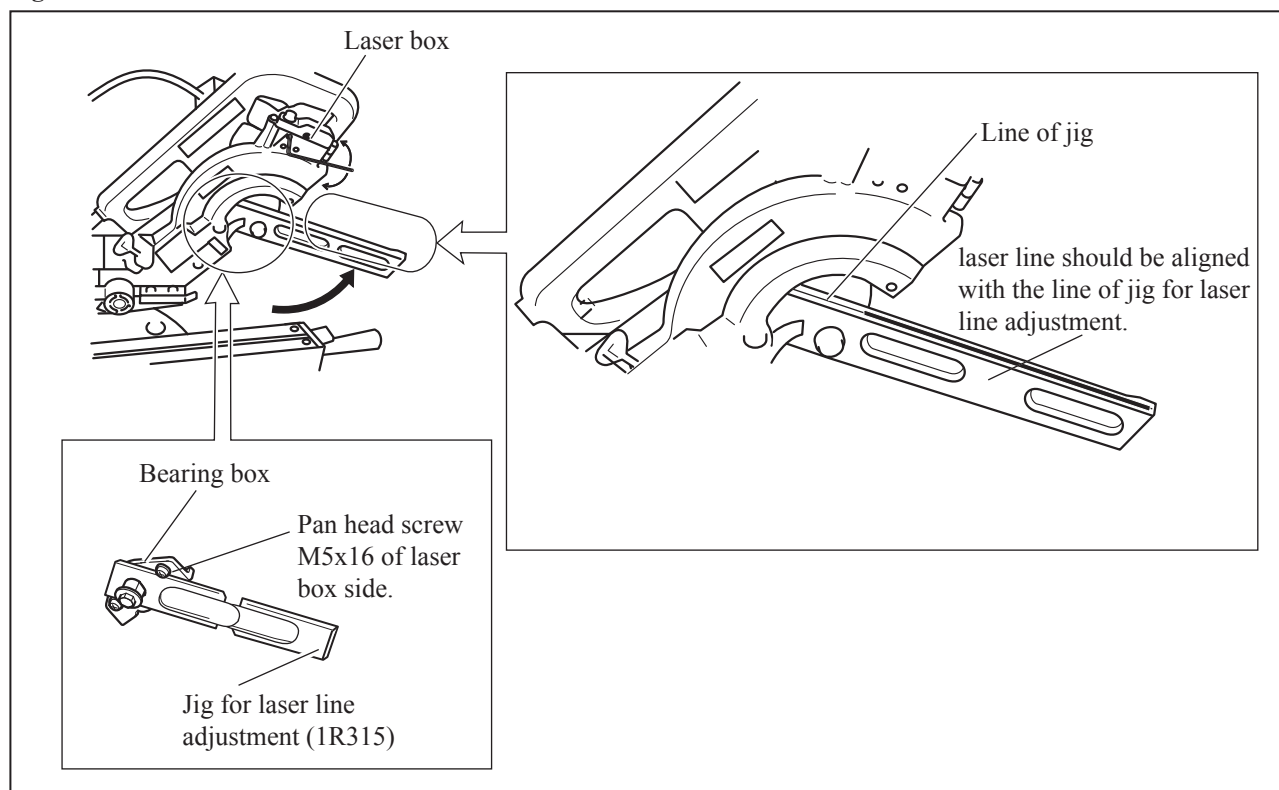

► Repair

(3) Adjustment of laser beam positioning (exclusively for LS0714FL/ LS0714L)

For safety and easy adjusting work, remove saw blade, safety cover section, flanges (outer and inner) and dust nozzle.

1. Mount Jig for laser line adjustment (1R315) to spindle. See **Fig. 20-2**.
2. Tear away a part of laserline label until hex socket head set screws M4x6 (A and B) come into your sight as **Fig.20-5**.
3. Connect the machine with power source, and turn on the switch of laser. See **Fig. 20-5**.
4. Slide the position of thumb screw M5x24 to the center point for the movable range in order to reserve the adjustment range to be wide. After that, drive the thumb screw M5x24 to fix the laser section.

Fig. 20-5

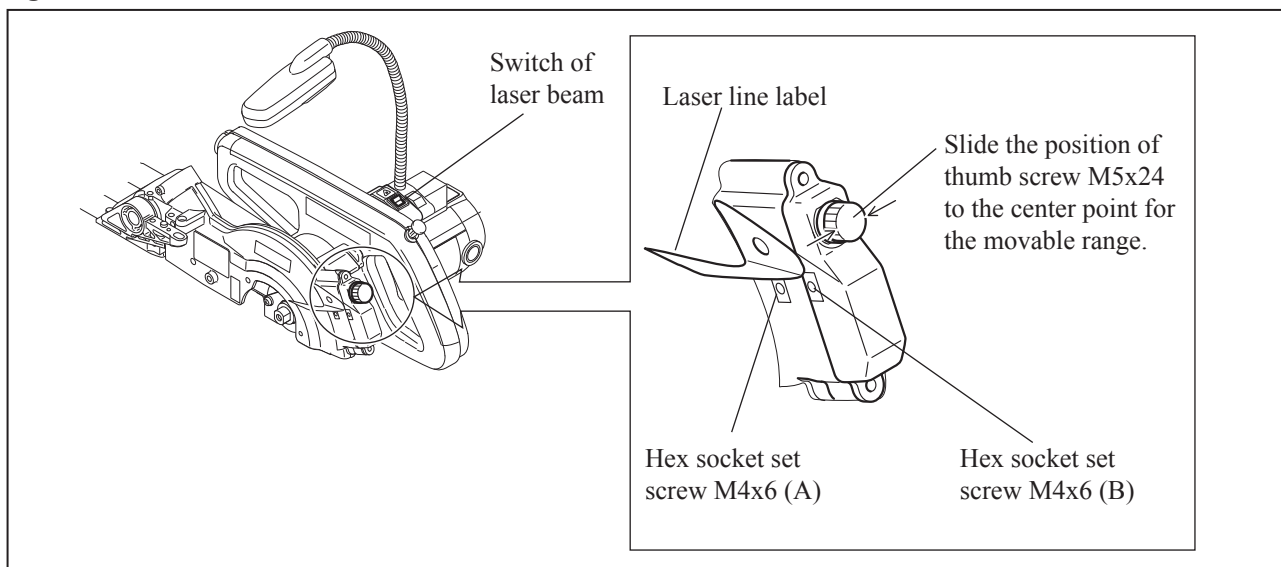

5. Lower the jig until it reaches the pan head screw M5x16 of link plate side. See **Fig. 20-3**.
6. Move the laser line to the closest position to the line of jig by adjusting with hex socket set screw M4x6(A). See **Fig. 20-6**.

Fig. 20-6

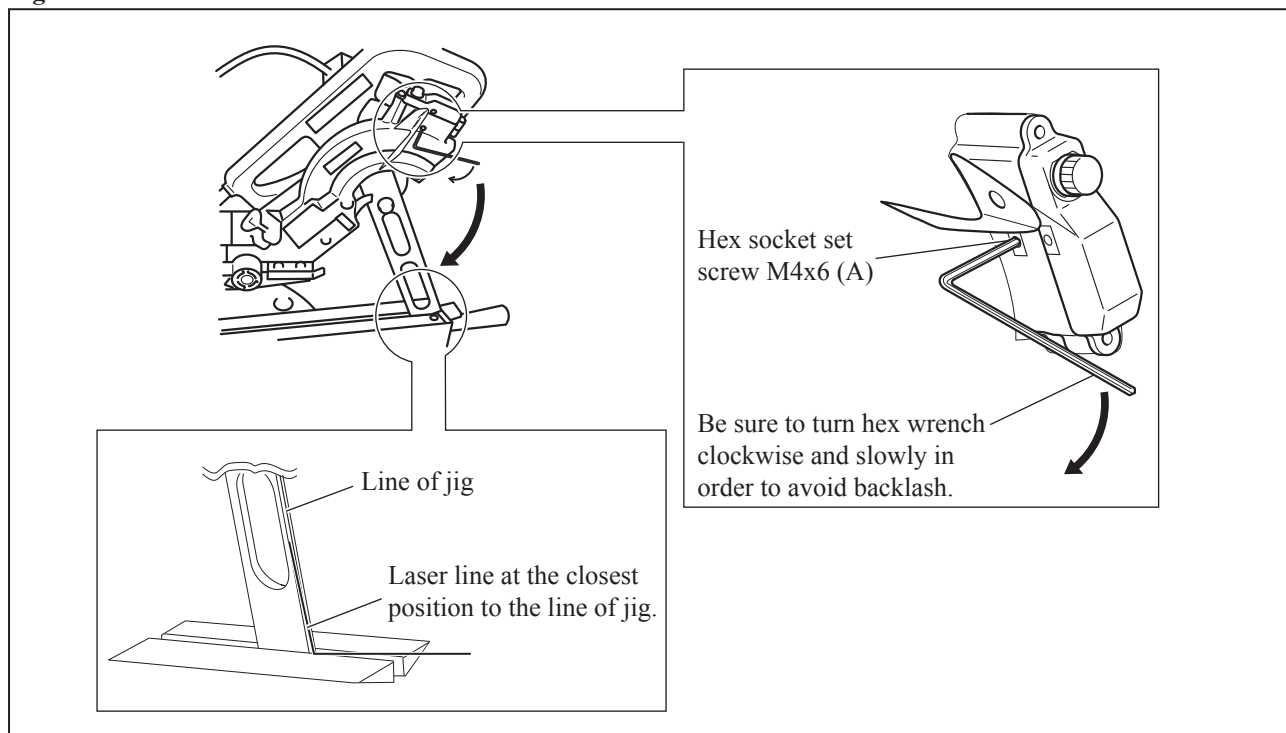

► Repair

7. Lift up the jig until it reach the pan head screw M5x16 of laser box side. See **Fig. 20-4**.
8. Adjust the laser line so as to parallel the line of jig by turning hex socket set screw M4x6 (B). See **Fig. 20-7**.

Fig. 20-7

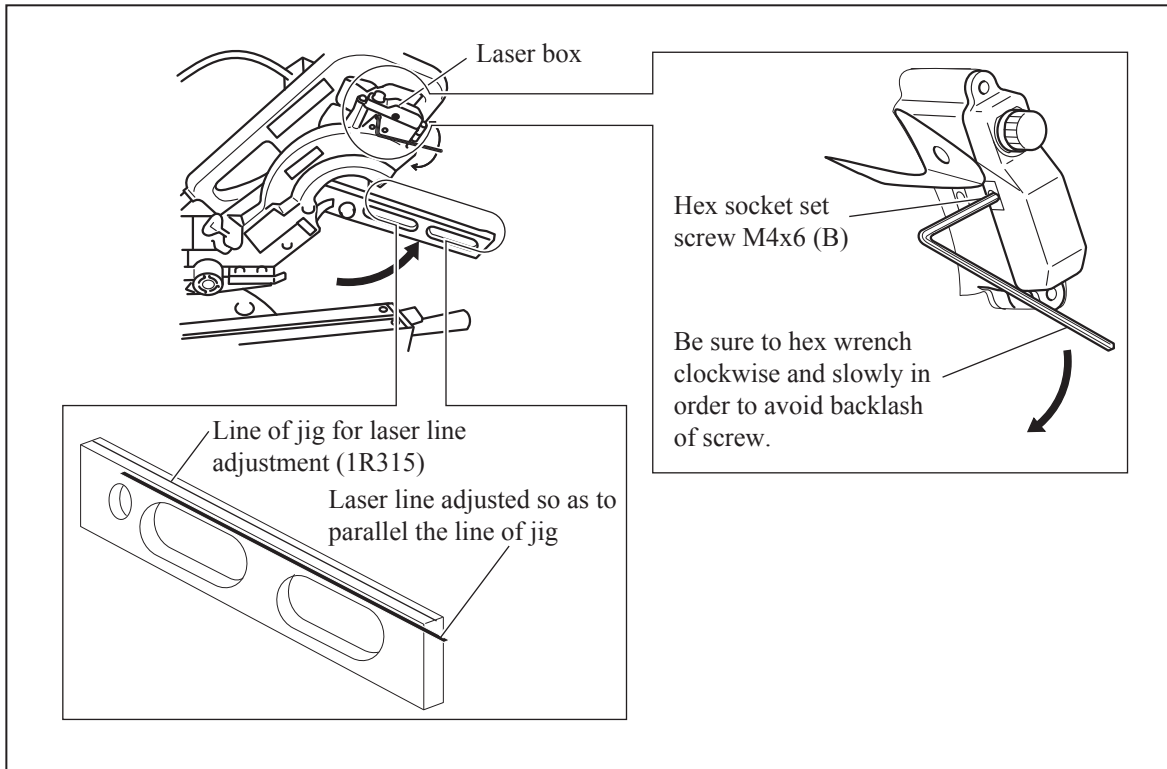

9. In order to move the laser line onto the line of jig for laser line adjustment, slide the position of thumb screw M5x24 to left or right as **Fig. 20-8**. Finally drive Thumb screw M5x24 to fix the laser section.

Fig. 20-8

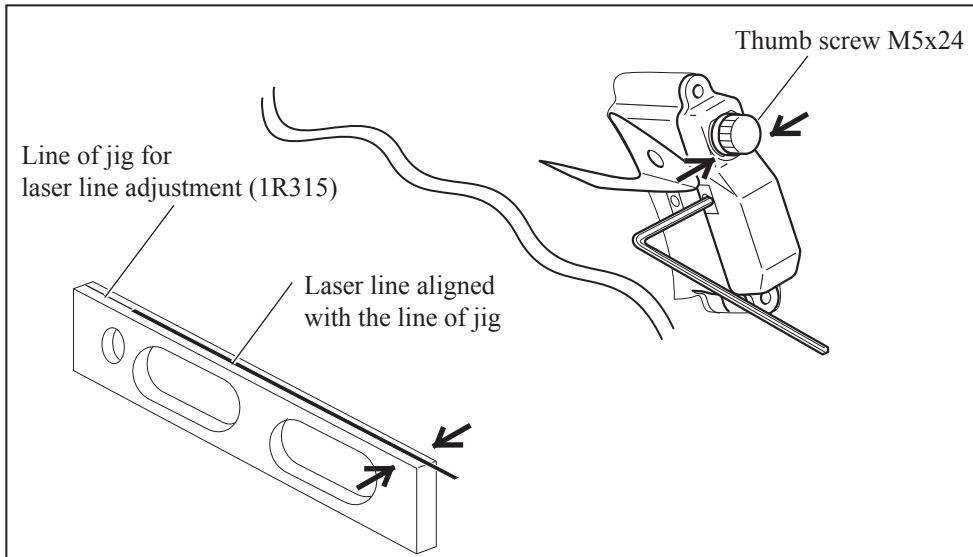

► Repair

10. Lower the jig again until it reaches the pan head screw M5x16 of link plate side. See **Fig. 20-6**.

11. Align the laser line with the line of jig by turning hex socket set screw M4x6 (A). See **Fig. 20-9**.

Fig. 20-9

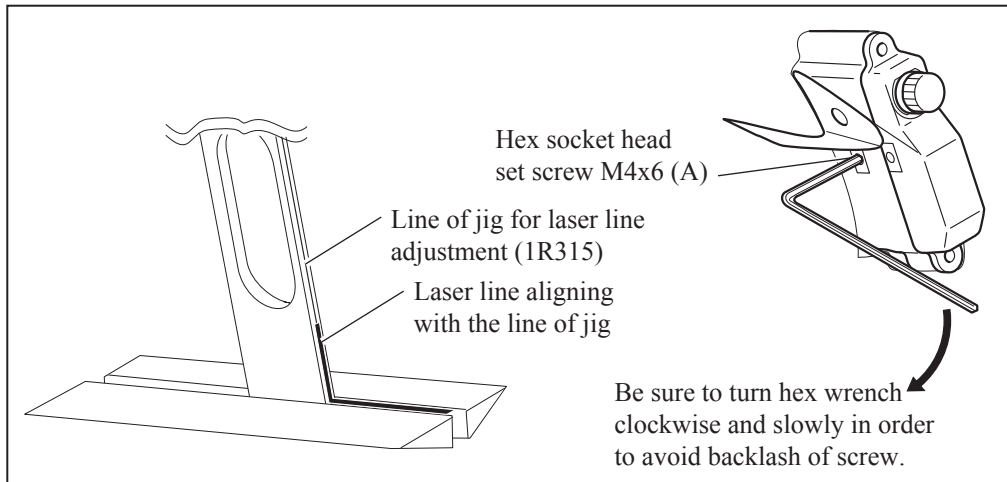

12. Lift up the jig again until it reaches the pan head screw M5x16 of laser box side. See **Fig. 20-7**.

13. Align the laser line with the line of jig by turning hex socket set screw M4x6 (B). See **Fig. 20-10**.

Fig. 20-10

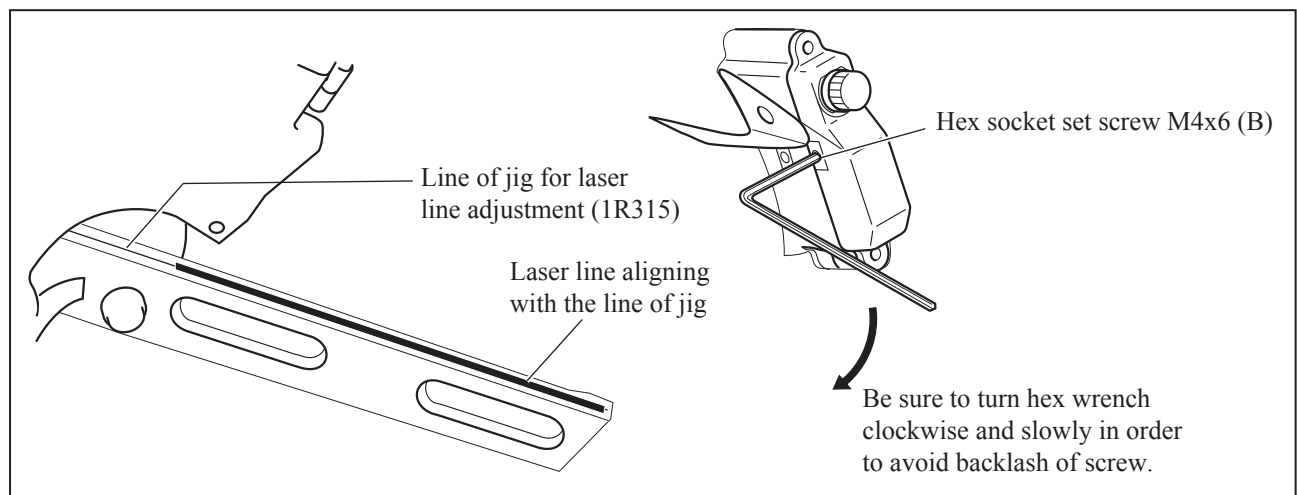

14. Repeat the steps 9, 10, 11, 12 and 13, until the laser line aligns with the line of jig as illustrated in **Fig. 20-3** and **Fig. 20-4**.

Caution: Laserline label should be pasted again after adjustment.

This prevents dust from invading into the laser circuit and hex socket set screws M4x6 (A and B).

► **Wiring of Lead Wire to Terminal Block**

(For all the subject models)

When connecting power supply cord with electrical parts in handle, strip the power supply cord to expose 50mm up to 70mm of one inner lead wire for connecting with Terminal as illustrated to right.

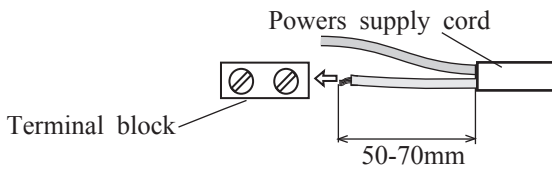

► **Circuit diagram**

LS0714FL (with Fluorescent light and laser marker)

Color index of lead wires' sheath			
Black		Orange	
White		Blue	
Red			

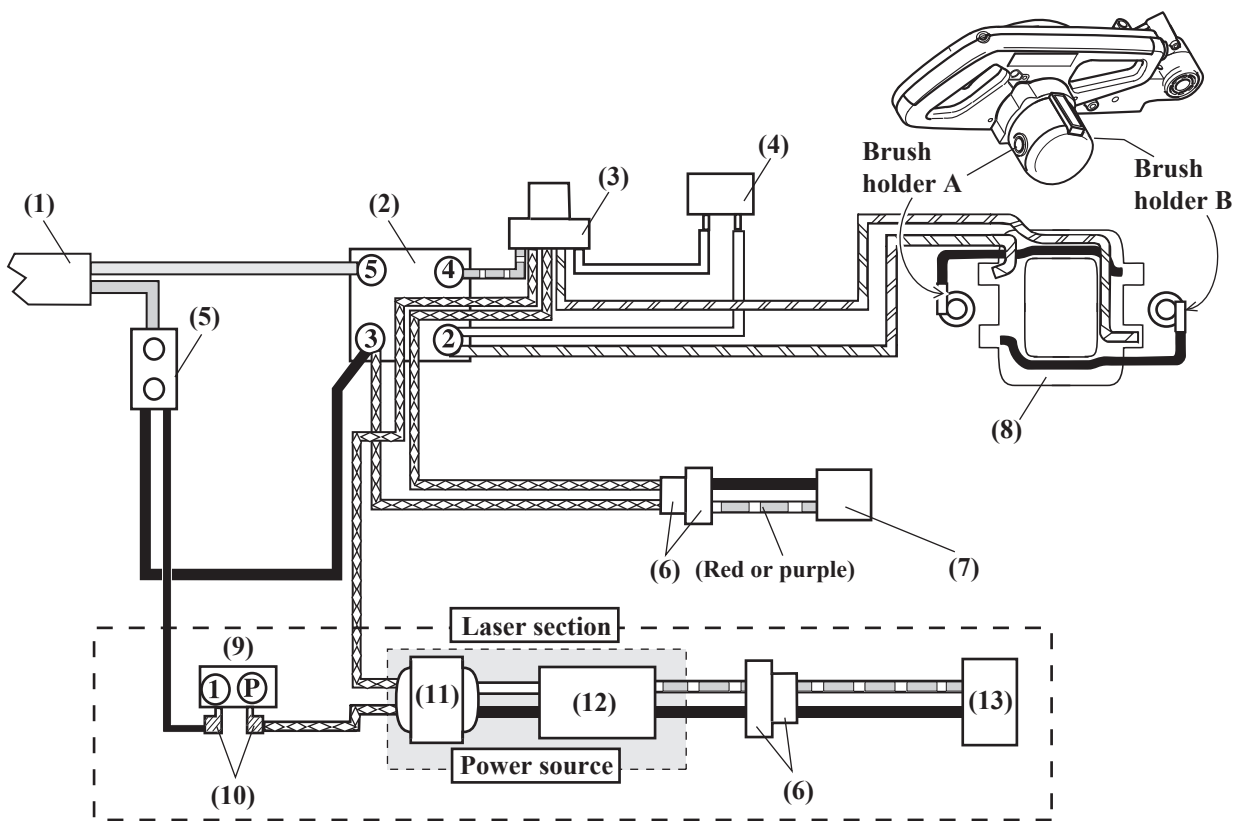

- | | | | |
|-------------------------|----------------------|---------------------------|--------------------|
| (1) Power supply cord | (5) Terminal block | (9) Laser switch | (13) Laser circuit |
| (2) Main switch | (6) Connectors | (10) Receptacle | |
| (3) Insulated connector | (7) Light assembly | (11) Transformer | |
| (4) Noise suppressor | (8) Support complete | (12) Printed wiring board | |

► Wiring diagram in Handle L

LS0714FL (with Fluorescent light and laser marker)

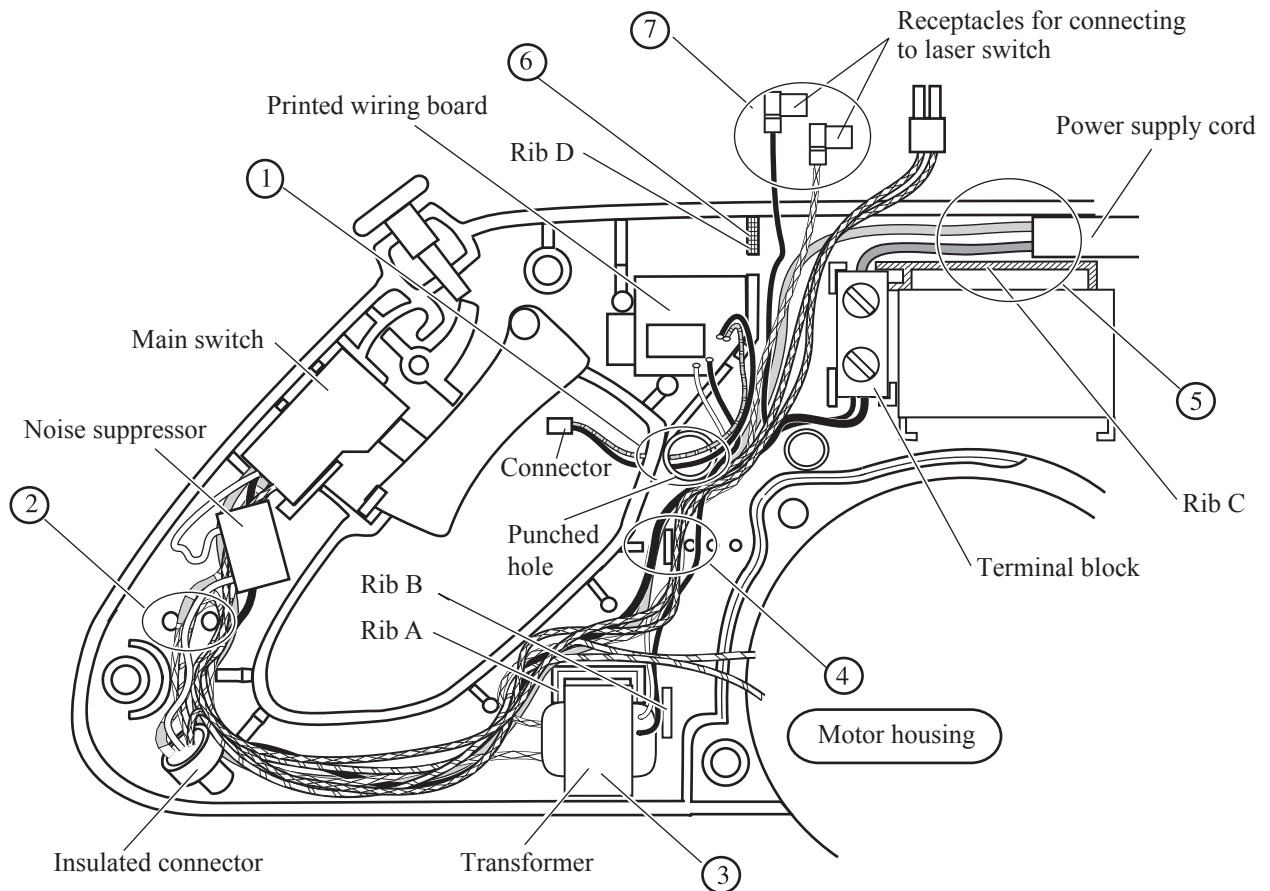



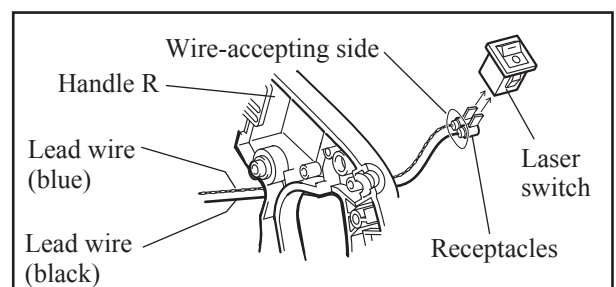

- ① Pass the lead wires (black and red) of wiring board through the punched hole.
- ② The following lead wires for connecting insulated connector should be put into lead wire holder so that insulated connector does not rise from handle L.
 - * Lead wire (red) to switch
 - * Lead wire (blue) to transformer
 - * Lead wire (blue) to light assembly
 - * Field lead wire (orange)
 - * Lead wire (white) of noise suppressor
- ③ Transformer must be mounted so that lead wires (black and white) face the side of handle R and are in the side of motor housing. If these lead wires go over Rib A/B, these are pinched between the Rib A/B and handle R. Therefore, fix them with full attention.
- ④ When putting the lead wires into lead wire holders, the thin lead wires have to be put under the thick lead wires so as not to rise from the original position.
- ⑤ Power supply cord should be put so that its sheath portion is between Rib C and the wall of housing L.
- ⑥ When putting handle R on housing L, be careful not to go over lead wires on Rib D. Otherwise it will happen pinching.
- ⑦ When connecting receptacles to laser switch, be sure to face its wire-accepting side to handle R. The receptacle with blue colored lead wire should be close to I mark on the laser switch. The receptacle with black colored lead wire should be close to O mark on the laser switch. See illustration below.



► **Circuit diagram**

LS0714F (with Fluorescent light)

Color index of lead wires' sheath			
Black		Orange	
White		Blue	
Red			

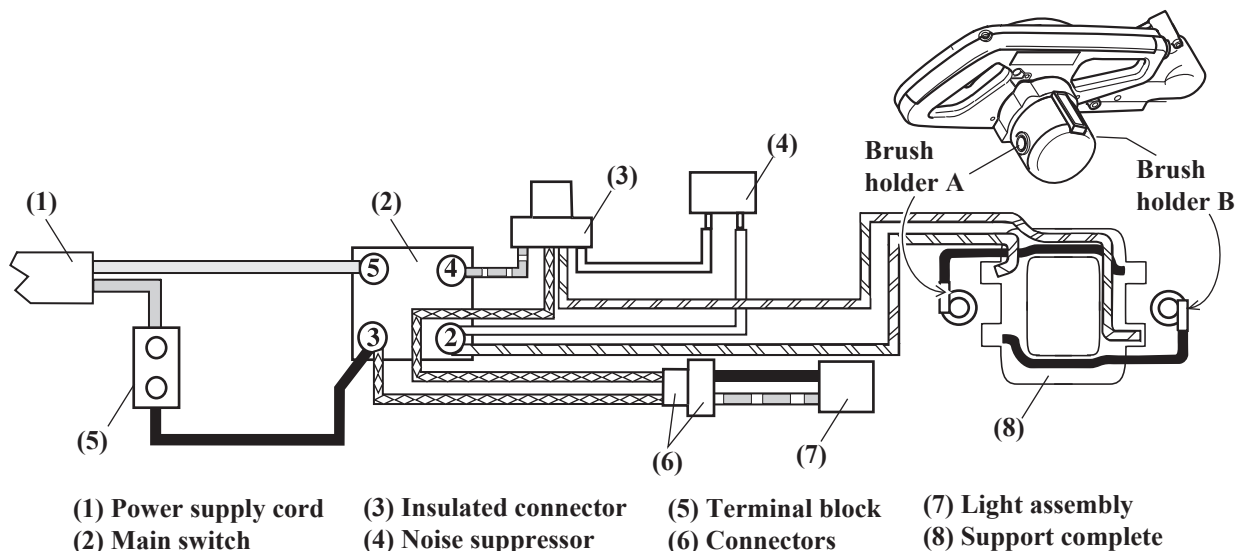

► **Wiring diagram in handle L**

LS0714F (with Fluorescent light)

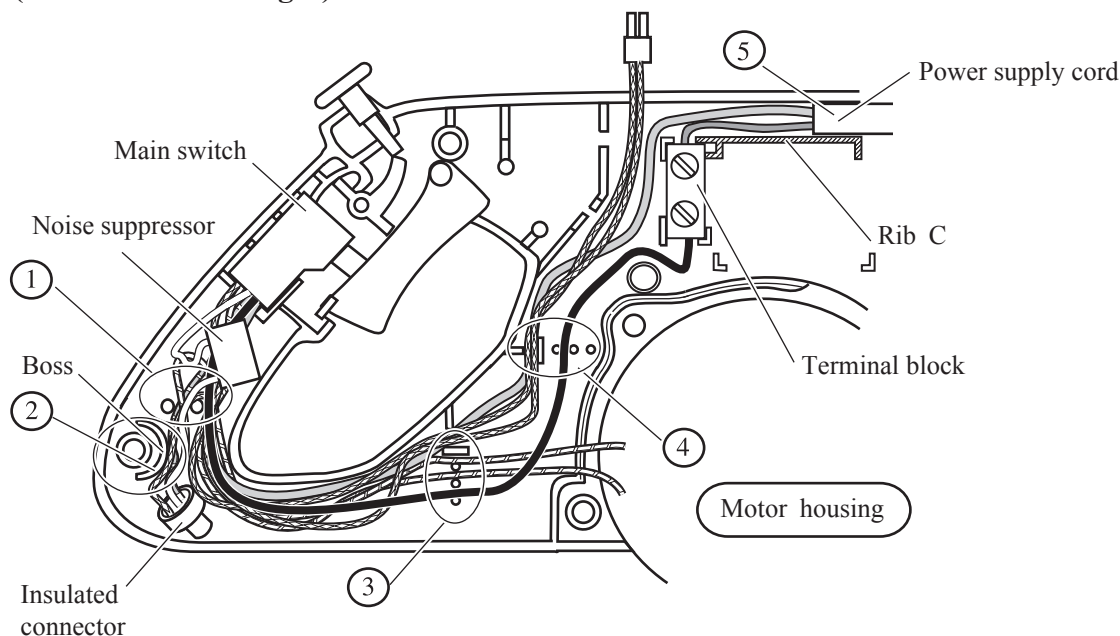

- ① The following lead wires for connecting insulated connector should be put into lead wire holder so that insulated connector does not rise from handle L.
 - * Lead wire (red) to switch
 - * Lead wire (blue) to light assembly
 - * Field lead wire (orange)
 - * Lead wire (white) of noise suppressor
- ② All lead wires have to be put on the right side of boss.
- ③ Put field lead wires (orange) into lead wire holder so that their wires do not sag in the motor housing.
- ④ When putting the lead wire into lead wire holders, the thin lead wires have to be put under the thick wires so as not to rise from the original position.
- ⑤ Power supply cord should be put so that its sheath portion is between Rib C and the wall of housing L.

► Circuit diagram

LS0714 (without Fluorescent light and laser)

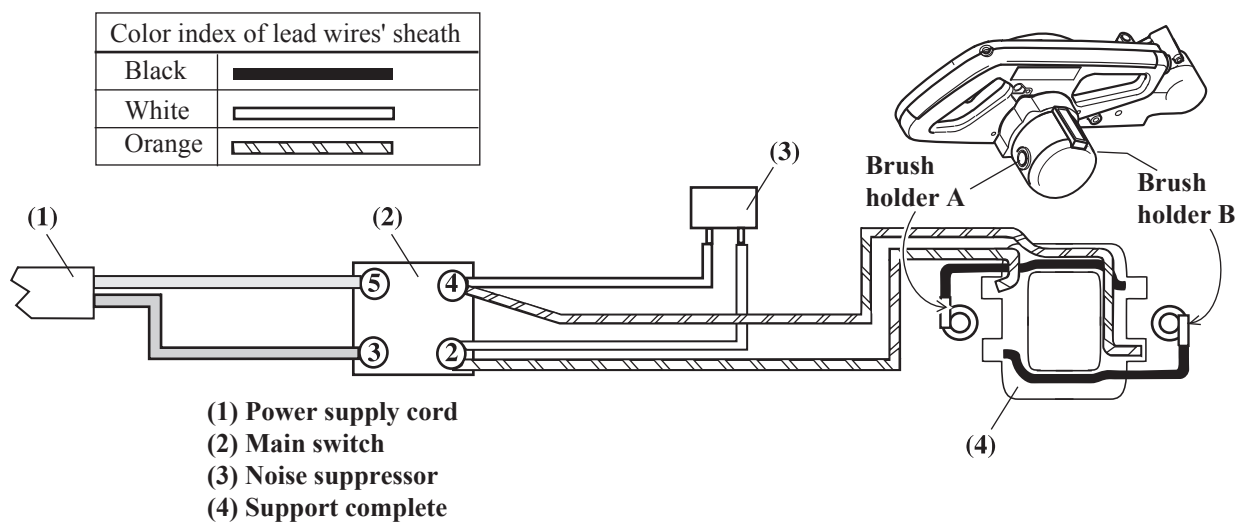

► Wiring diagram in handle L



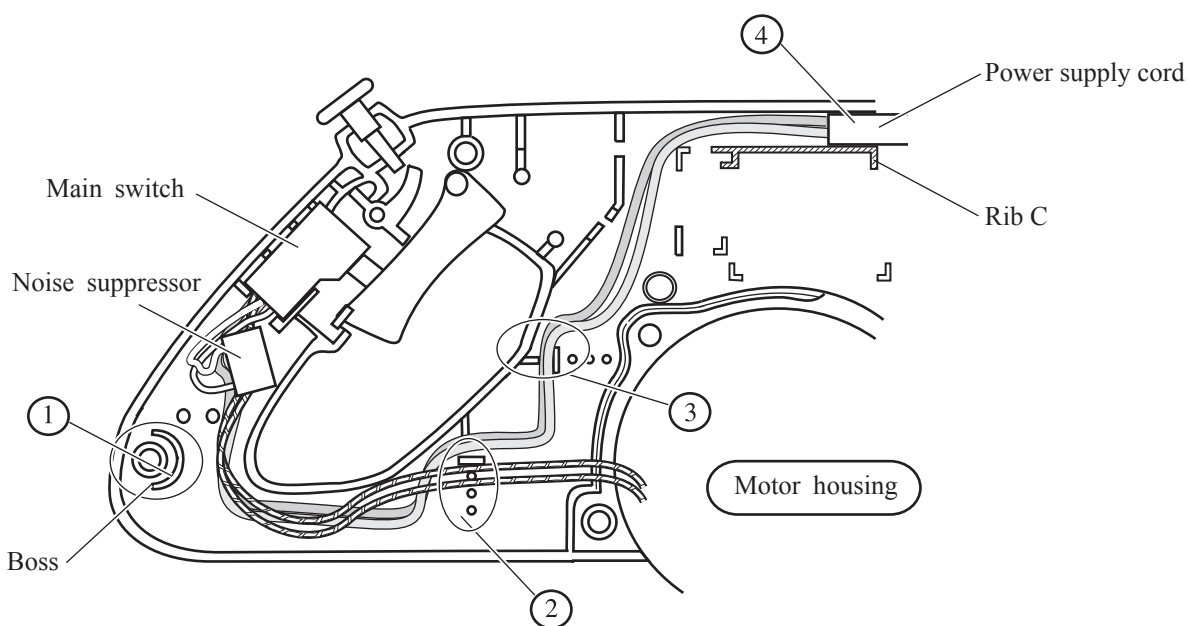

LS0714 (without Fluorescent light and laser)



- ① All lead wires have to be put on the right side of boss.
- ② Put field lead wires (orange) into lead wire holder so that their wires do not sag in the motor housing.
- ③ These lead wires have to be put into lead wire holder.
- ④ Power supply cord should be put so that its sheath portion is between Rib C and the wall of housing L.

► **Circuit diagram**

LS0714L (with laser marker)

Color index of lead wires' sheath			
Black		Orange	
White		Blue	
Red			

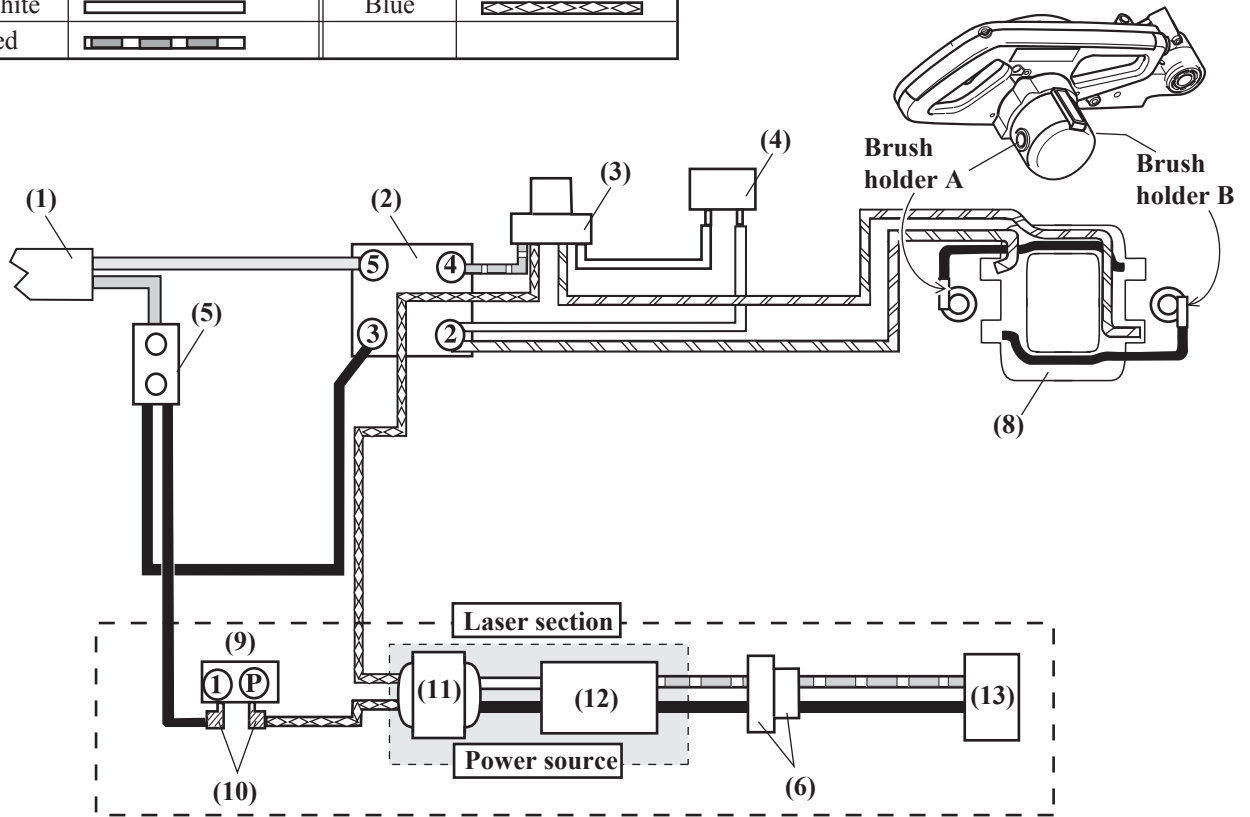

- | | | | |
|-------------------------|----------------------|---------------------------|--------------------|
| (1) Power supply cord | (5) Terminal block | (9) Laser switch | (13) Laser circuit |
| (2) Main switch | (6) Connectors | (10) Receptacle | |
| (3) Insulated connector | | (11) Transformer | |
| (4) Noise suppressor | (8) Support complete | (12) Printed wiring board | |

► Wiring diagram in Handle L

LS0714L (with laser marker)

When connecting power supply cord with electrical parts in handle, strip the power supply cord to expose 50mm up to 70mm of one inner lead wire for connecting with Terminal as illustrated to right.

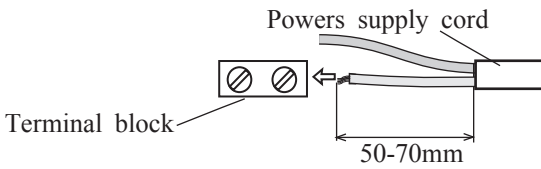

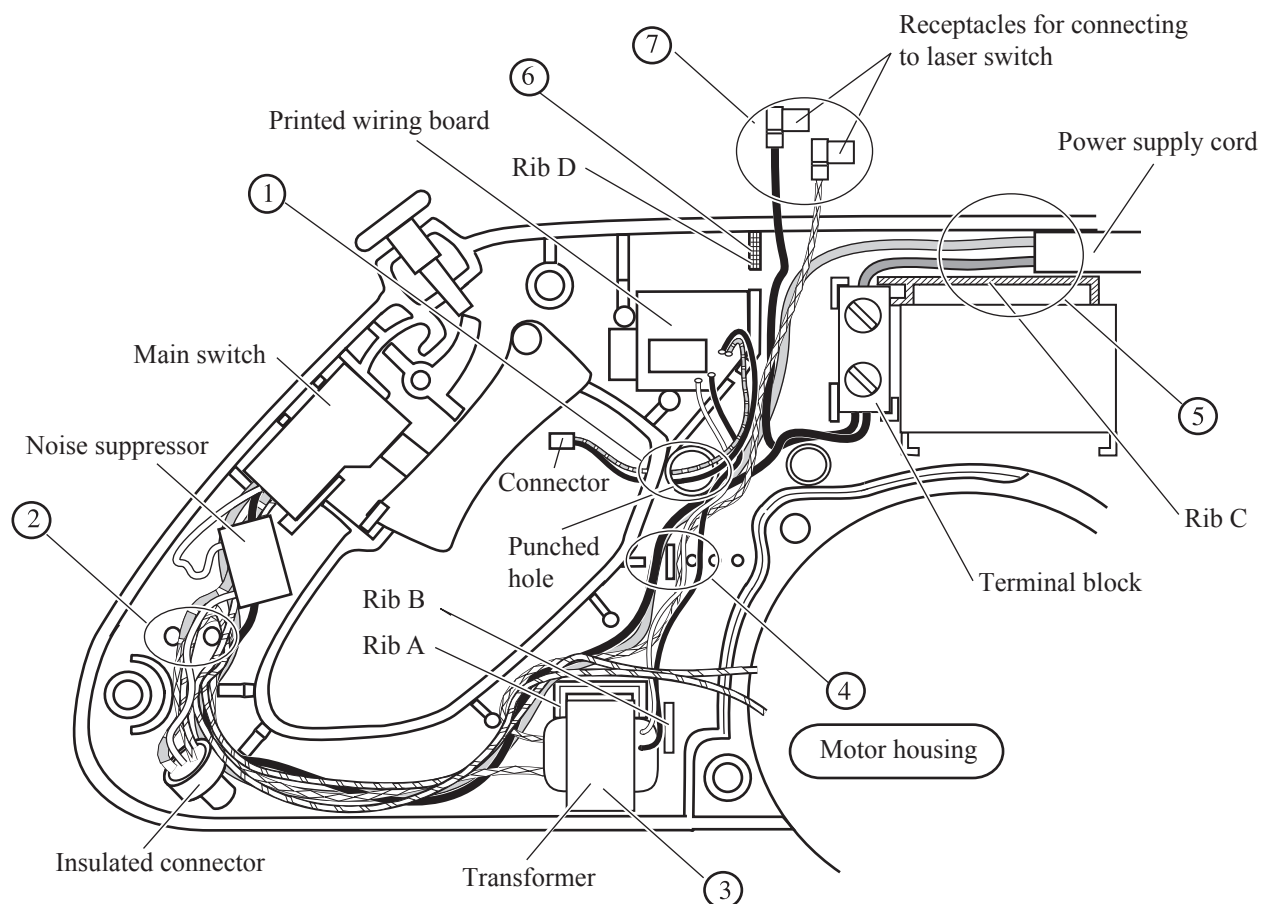

- ① Pass the thin lead wires (black and red) with connector of wiring board through the punched hole.
- ② The following lead wires for connecting insulated connector should be put into lead wire holder so that insulated connector does not rise from handle L.
 - * Lead wire (red) to switch
 - * Lead wire (blue) to transformer
 - * Field lead wire (orange)
 - * Lead wire (white) of noise suppressor
- ③ Transformer must be mounted so that lead wires (black and white) face the side of handle R and are in the side of motor housing. If these lead wires go over Rib A/B, these are pinched between the Rib A/B and handle R. Therefore, fix them with full attention.
- ④ When putting the lead wires into lead wire holders, the thin lead wires have to be put under the thick lead wires so as not to rise from the original position.
- ⑤ Power supply cord should be put so that its sheath portion is between Rib C and the wall of housing L.
- ⑥ When putting handle R on housing L, be careful not to go over lead wires on Rib D. Otherwise it will happen pinching.
- ⑦ When connecting receptacles to laser switch, be sure to face its wire-accepting side to handle R. The receptacle with blue colored lead wire should be close to I mark on the laser switch. The receptacle with black colored lead wire should be close to O mark on the laser switch. See illustration below.

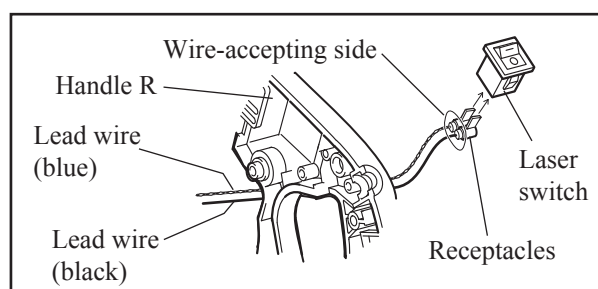

Free Manuals Download Website

<http://myh66.com>

<http://usermanuals.us>

<http://www.somanuals.com>

<http://www.4manuals.cc>

<http://www.manual-lib.com>

<http://www.404manual.com>

<http://www.luxmanual.com>

<http://aubethermostatmanual.com>

Golf course search by state

<http://golfingnear.com>

Email search by domain

<http://emailbydomain.com>

Auto manuals search

<http://auto.somanuals.com>

TV manuals search

<http://tv.somanuals.com>