

TECHNICAL INFORMATION



PRODUCT

P 1 / 6

Models No. ▶ TD090D

Description ▶ 10.8V Cordless Impact Driver

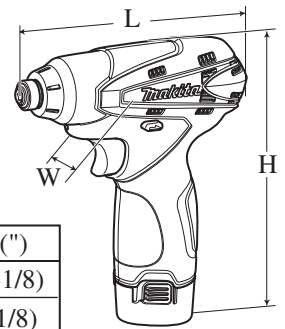

CONCEPT AND MAIN APPLICATIONS

Model TD090D is a 10.8V cordless impact driver compact and lightweight for easy handling, but featuring high operation efficiency.

Uses new 10.8V Li-ion battery of stick type as a power unit.

Dimensions: mm (")	
Length (L)	155 (6-1/8)
Width (W)	54 (2-1/8)
Height (H)	178 (7)

This product is available in the following variations.

Model No.	Battery		Charger	Plastic carrying case	Housing color	Offered to
	type	quantity				
TD090D	BL1013 (Li-ion 1.3Ah)	2	DC10WA	Yes	Makita-blue	USA, Canada Mexico, Panama
TD090DW					white	
TD090DWE					Makita-blue	All countries except the four listed above
TD090DWEW					white	

The models also includes the accessories listed below in "Standard equipment".

► Specification

Battery	Cell	Li-ion
	Voltage: V	10.8
	Capacity: Ah	1.3
	Charging time (approx.): min.	50 with DC10WA
Max. output: W		115
Driving shank: mm (")		6.35 (1/4) Hex
Capacities	Machine screw	M4 - M8 (5/32 - 5/16")
	Standard bolt	M5 - M12 (3/16 - 1/2")
	High tensile bolt	M5 - M10 (3/16 - 3/8")
	Coarse thread screw	22 - 90mm (7/8 - 3-1/2")
Impacts per min.: min-1=ipm		0 - 3,000
No load speed: min-1= rpm		0 - 2,400
Max. fastening torque: N.m [kgf.cm] (in.lbs)		90 [910] (800)
Electric brake		Yes
Variable speed control by trigger		Yes
Reverse switch		Yes
LED job light		Yes
Net weight [with battery BL1013]: kg (lbs)		0.92 (2.0)

► Standard equipment

Holster 1 pc

Note: The standard equipment for the tool shown above may differ by country.

► Optional accessories

Phillips bits, Square bits, Socket bits, Drill chucks, Hex shank auger bits,
Hole saws for impact driver, Bit piece,
Charger DC10WA, Battery BL1013

► **Repair**

CAUTION: Remove the bit and the battery from the machine for safety before repair/ maintenance in accordance with the instruction manual!

[1] NECESSARY REPAIRING TOOLS

Code No.	Description	Use for
1R041	Vise plate	Removing of Hammer case complete
1R045	Gear extractor (large)	Removing of Hammer
1R346	Center attachment for 1R045	
1R223	Torque wrench shaft	Removing of Hammer case complete
1R224	Ratchet head for 1R223	
1R232	Pipe 30	Removing of Bit sleeve
1R288	Screwdriver Magnetizer	Removing Steel balls
1R291	Retaining Ring S and R Pliers	Removing Bit sleeve
134844-7	Socket 27 -50	Disassembling of Hammer case complete

[2] LUBRICATION

Apply Makita grease N. No.2 to the portions designated with the black triangle and Makita grease FA No.2 to the portions designated with gray triangle to protect parts and product from unusual abrasion.

Item No.	Description	Portion to lubricate	Lubricant	Amount
⑰	Anvil	Outer periphery where the neck of Hammer case contacts Hole into which the bottom of Anvil is inserted	Makita grease FA. No.2	a little
⑳	Spindle			
⑲	Steel ball 3 (24 pcs.)	Whole portion	Makita grease N. No.2	a little
㉓	Steel ball 4.8 (2 pcs.)			
㉟	DC motor	Pinion teeth that engages with Spur gear 17		1g

Fig. 1

▼ Makita grease FA. No.2
▼ Makita grease N No. 2

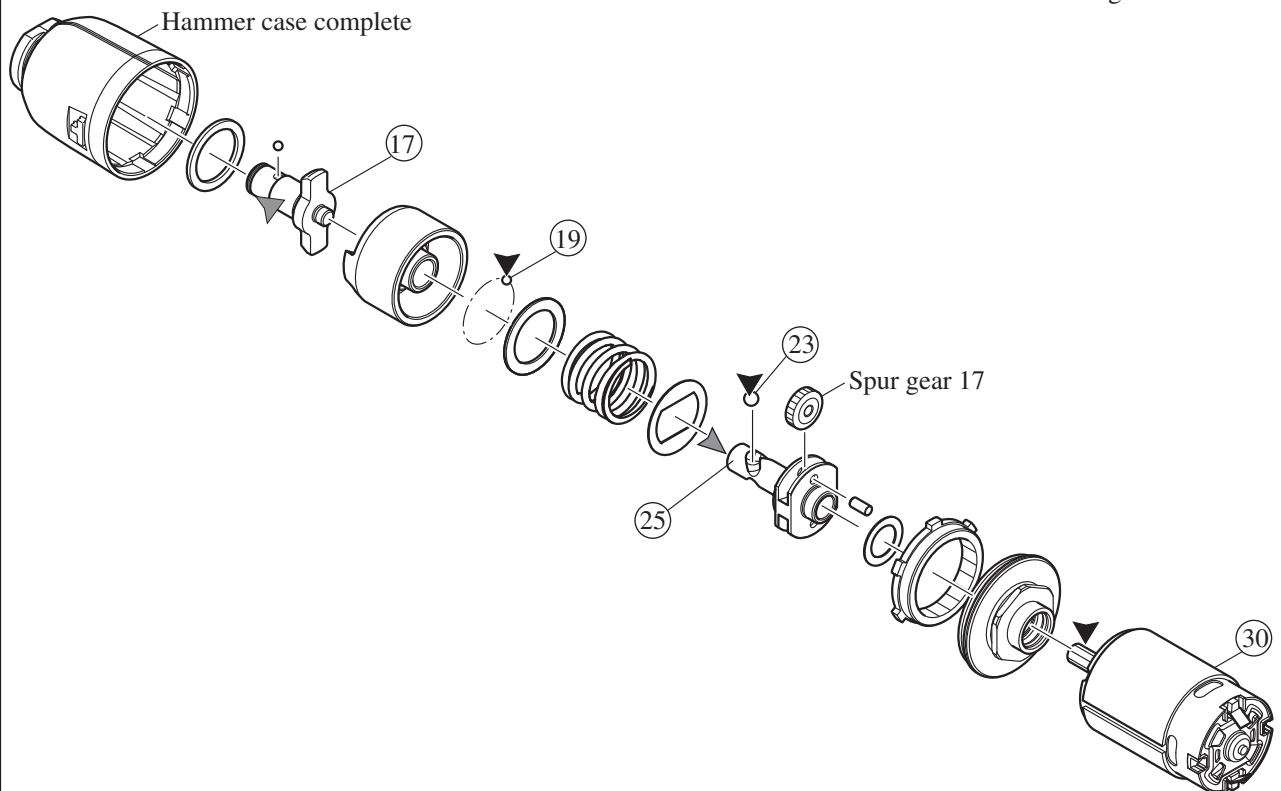

► Repair

[2] DISASSEMBLY/ASSEMBLY

[3]-1. Hammer case section

DISASSEMBLING

- 1) Remove Bumper from Hammer case complete. (**Fig. 2**)
- 2) Remove two Set plates with which Housings L and R are assembled to one another as follows:
Insert a small slotted screwdriver through the punched hole of Set plate and move Set plate in the direction of the arrow using the screwdriver. (**Fig. 3**)
- 3) Remove Housing R from Housing L by removing Bind PT3x6 tapping screws (6pcs.).
- 4) Remove Hammer case section and DC motor section together at one time, and then separate Hammer case section from DC motor section.
- 5) Clamp the flats of Hammer case complete in a vise with 1R041 as illustrated in **Fig.4**, and fit Socket 27-50 into the hexagon of Bearing box complete. Turn Socket 27-50 clockwise using 1R224 and 1R223 to remove the hexagon of Bearing box complete. Hammer section, Internal gear 43 and Bearing box complete can be separated from Hammer case complete.

Fig. 2

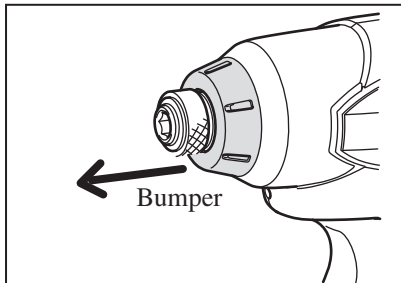

Fig. 3

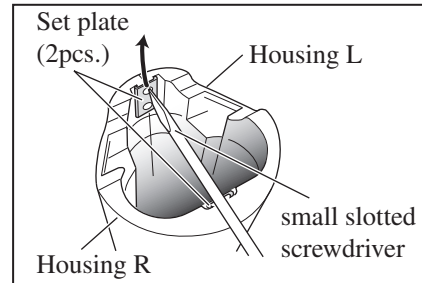
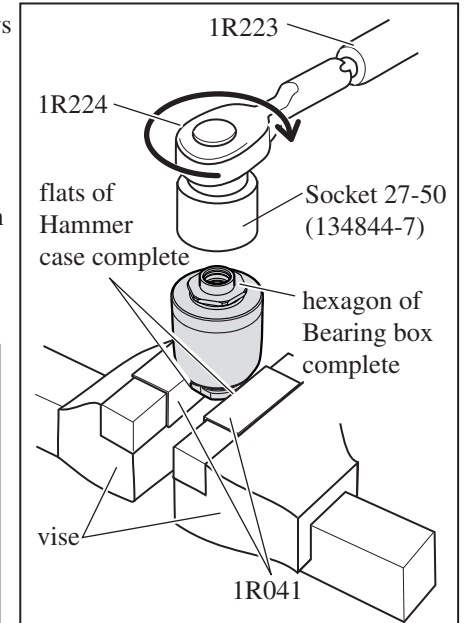

Fig. 4



ASSEMBLING

- 1) Put Bearing box on a worktable and stack Internal gear 53, Hammer section and Hammer case complete (including Anvil and Bit sleeve, etc.) vertically on Bearing box as illustrated in **Fig. 5**. Then fasten Bearing box to Hammer case complete by turning Socket 27-50 counterclockwise to 25 up to 30N.m. with 1R224 and 1R223.
- Note:** Internal gear 43 is directional as illustrated in **Figs. 5 and 6**. Therefore;
- fit the internal ring portion into the groove of Bearing box.
 - fit six protrusions into the grooves of Hammer case complete.

Fig. 5

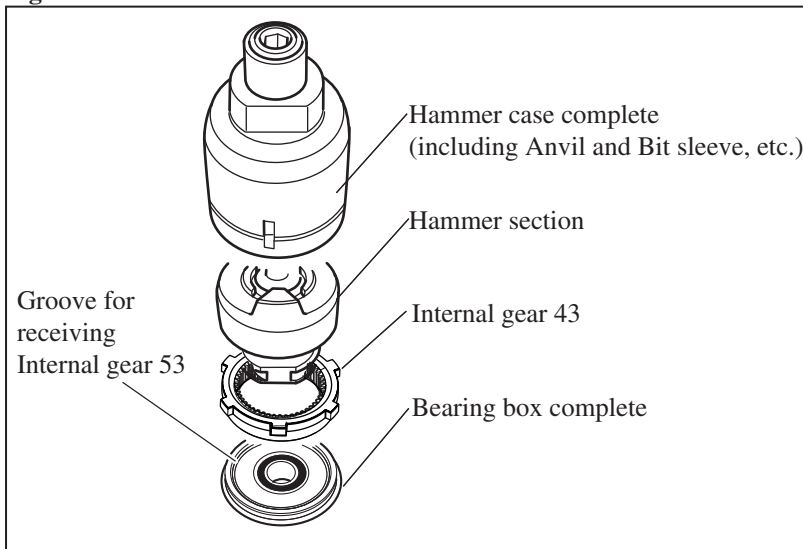
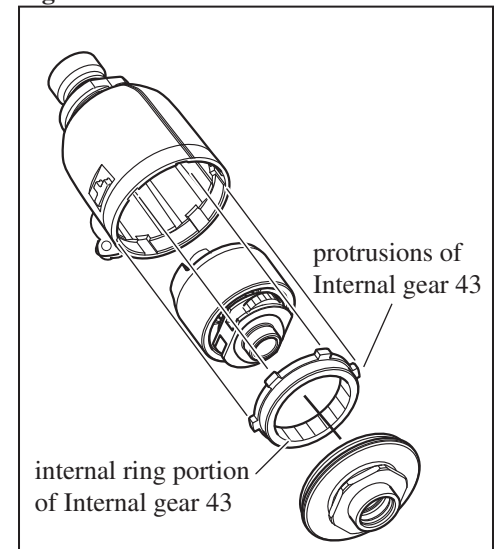

Fig. 6



- 2) Engage the pinion gear of DC motor with the assembled Hammer case section.
- 3) Set the assembled Hammer case section with DC motor to Housing L.
- 4) Do the reverse of the disassembling step to fix Housing L to Housing R. Refer to **Fig. 3**.
- 5) Mount Bumper on Hammer case complete. (**Fig. 2**)

► Repair

[3]-2. Hammer section

DISASSEMBLING

- 1) Remove Hammer section in accordance with [3]-1. Hammer case section.
 - 2) Press down Hammer using 1R045 and 1R346 to align the opening for Steel ball insertion with the top of cam grooving on Spindle. And then, remove Steel ball 4.8 from Spindle. (Fig. 7)
 - 3) Hold Hammer section as illustrated in Fig. 8 and release it from 1R346 and 1R045.
- Note:** Do not hold 1R346 and 1R045 as illustrated in Fig. 9 when releasing Hammer section from them.
Failure to follow this instruction could cause Steel balls to get out of hammer.
- 4) Hammer section can be disassembled as illustrated in Fig. 10. Flat washer 20 and Steel balls 3 can be removed. (Fig. 11)

Fig. 7

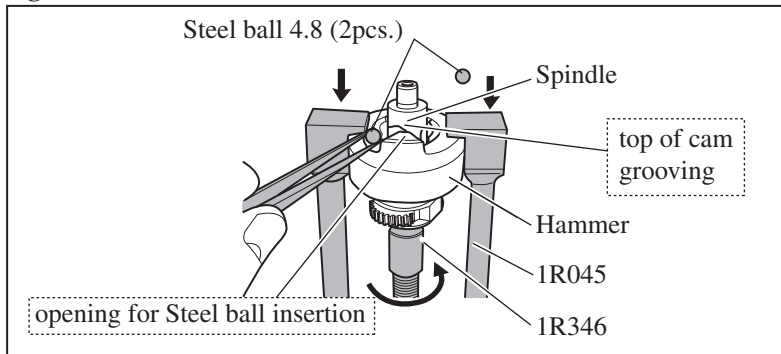

Fig. 8

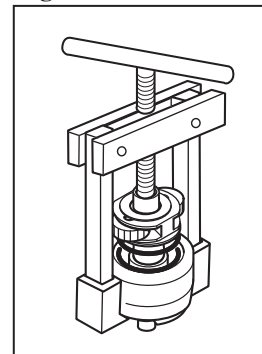

Fig. 9

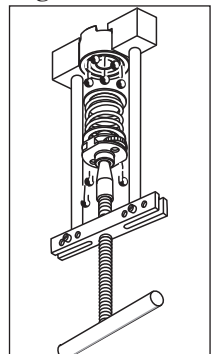

Fig. 10

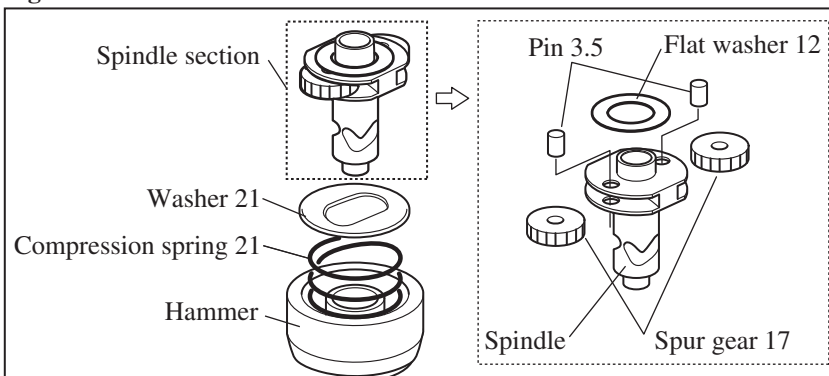
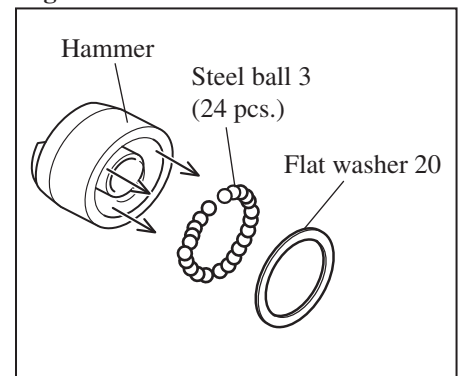

Fig. 11



ASSEMBLING

Take the reverse of the disassembling step.

Note: Put Steel ball 3 (24pcs.) into Hammer as illustrated in Fig. 12.

Space equivalent to one Steel ball proves Hammer and Steel ball 3 (24pcs.) are normal.

Fig. 12

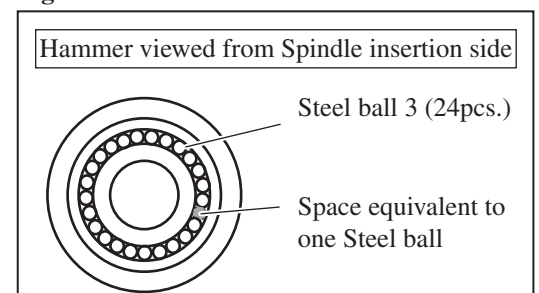

[3]-3. Assembling F/R Change Lever

Link the notch of F/R change lever and the protrusion of Switch, then install them in Housing L. (Fig. 13)

Fig. 13

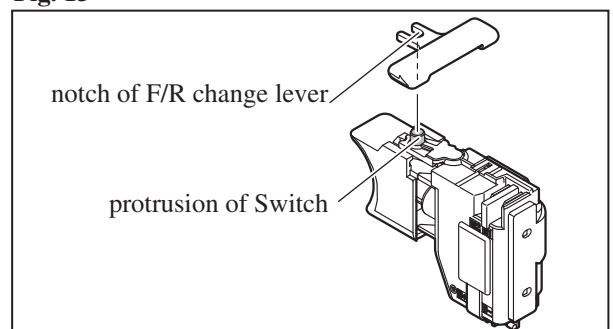

► Repair

[3]-4. Bit Holder Section and Anvil

DISASSEMBLING

- (1) Disassemble Hammer case complete. See Figs. 2 to 5.
- (2) Put Hammer case complete on 1R232 to disassemble Ring spring 11 easily. See Fig. 14.
- (4) Remove Ring spring 11 as illustrated in Fig. 15. Now Bit holder section can be disassembled as illustrated in Fig. 16.

Fig. 14

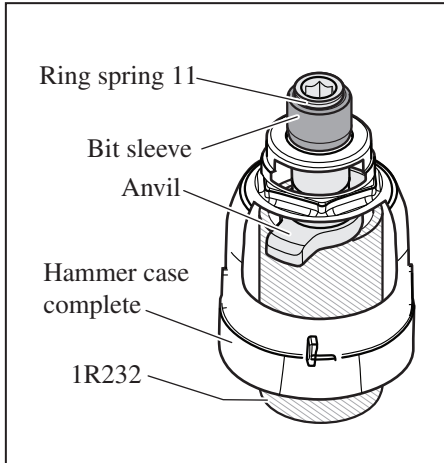

Fig. 15

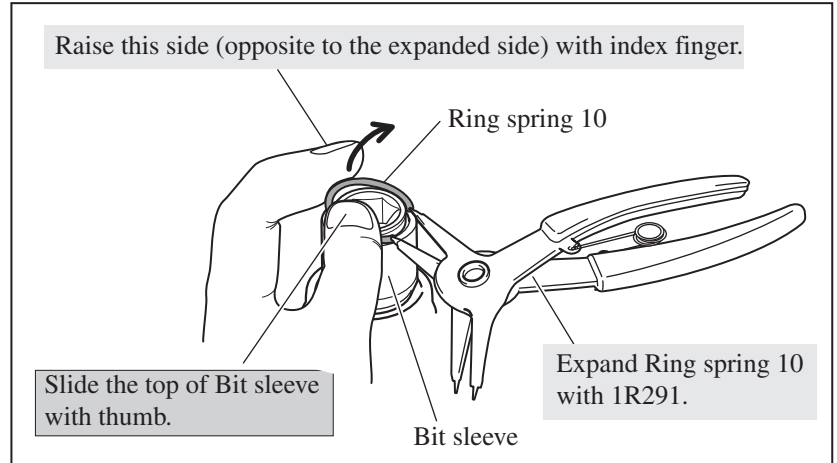
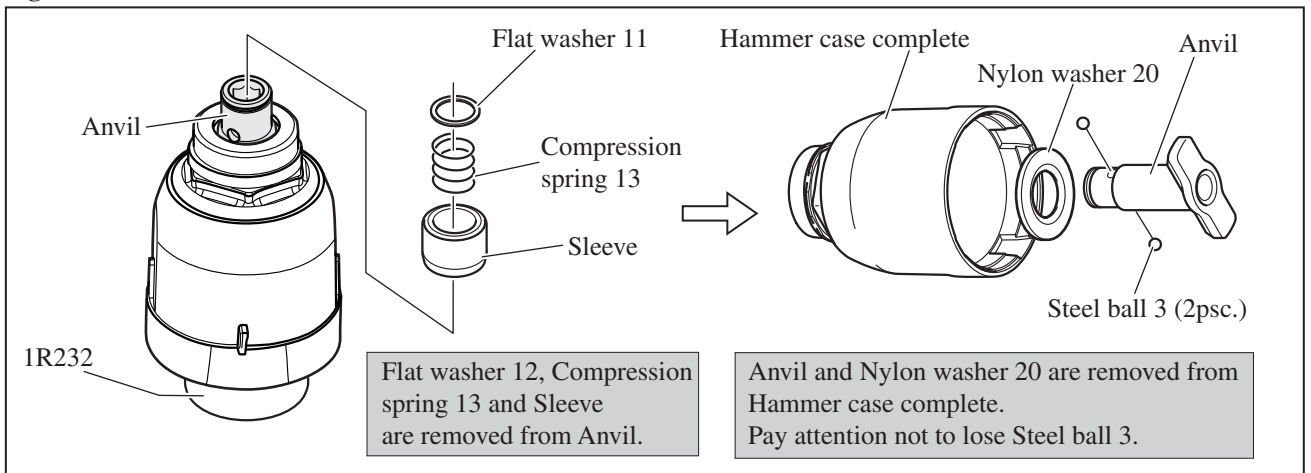

Fig. 16



ASSEMBLING

Take the reverse of the disassembling step.

► Circuit diagram

Fig. D-1

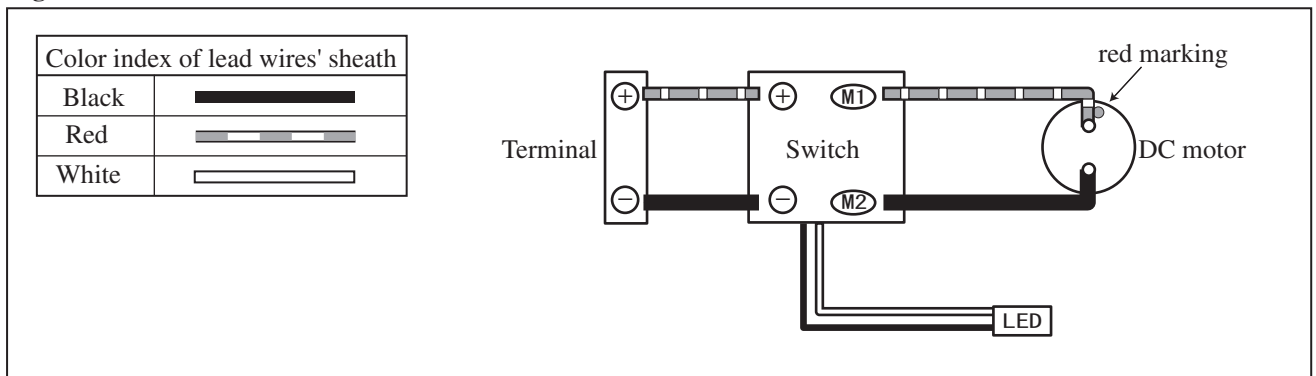

► **Wiring diagram**

Fig. D-2

Pay attention to the directions of lead wires and connect Flag receptacles to electrical parts.
Refer to the following illustration.

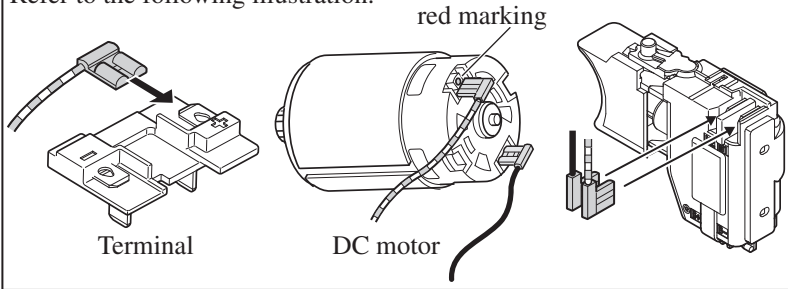

Fig. D-3

Before installing Switch in Housing R, route Lead wires as illustrated below and connect two Connectors. Do not put their Lead wires on the ribs of Housing L.

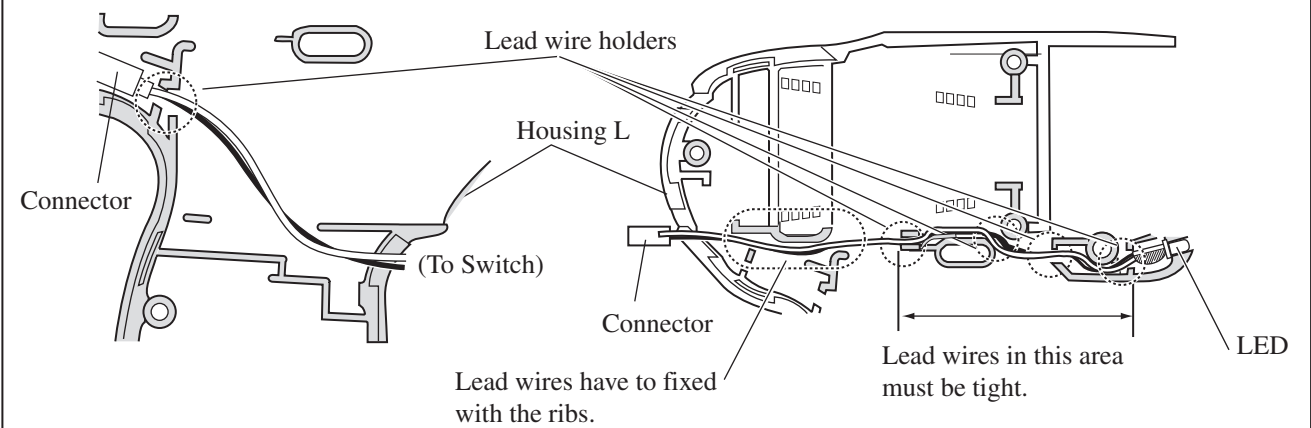
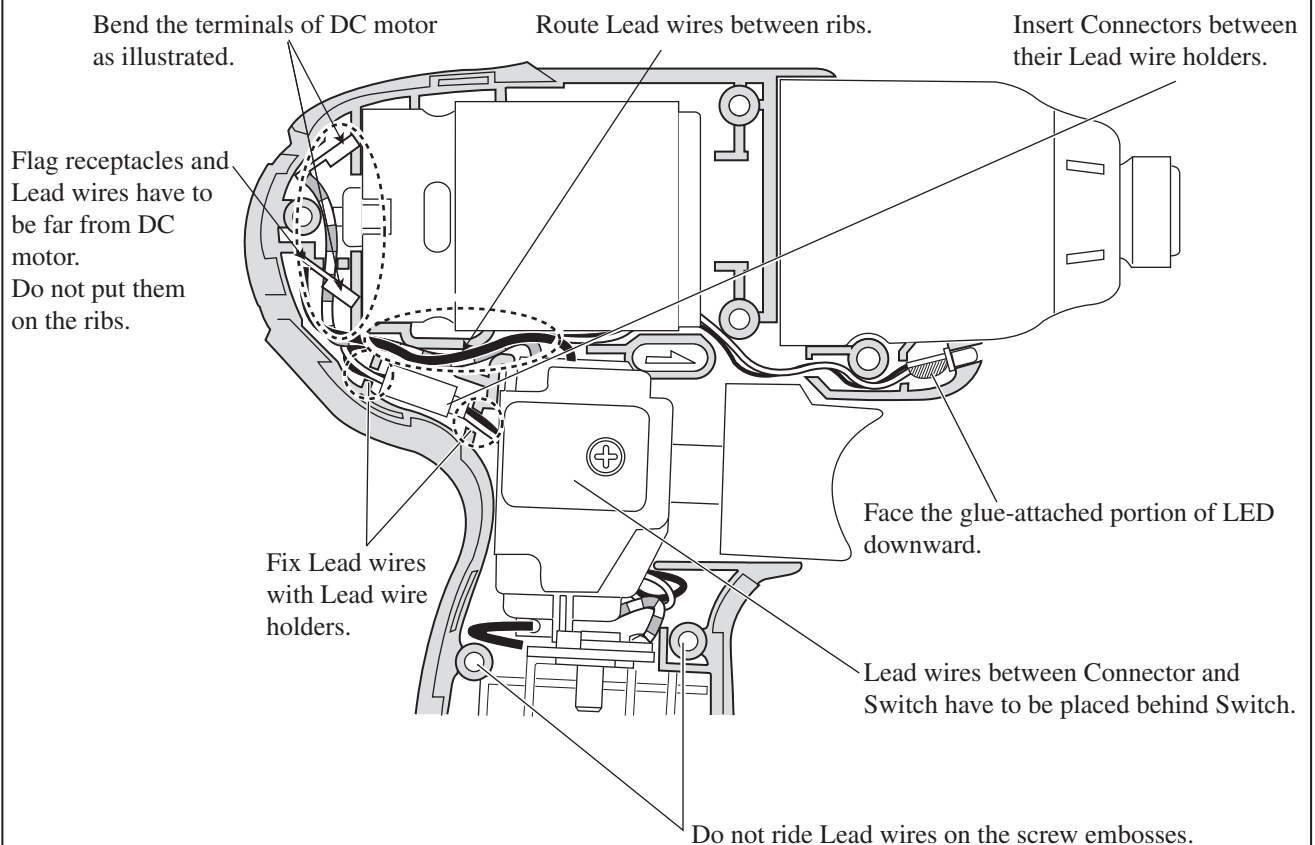

Fig. D-4



Free Manuals Download Website

<http://myh66.com>

<http://usermanuals.us>

<http://www.somanuals.com>

<http://www.4manuals.cc>

<http://www.manual-lib.com>

<http://www.404manual.com>

<http://www.luxmanual.com>

<http://aubethermostatmanual.com>

Golf course search by state

<http://golfingnear.com>

Email search by domain

<http://emailbydomain.com>

Auto manuals search

<http://auto.somanuals.com>

TV manuals search

<http://tv.somanuals.com>