

Makita GENERATOR

アメリカ

G series
MODEL **G12010R**

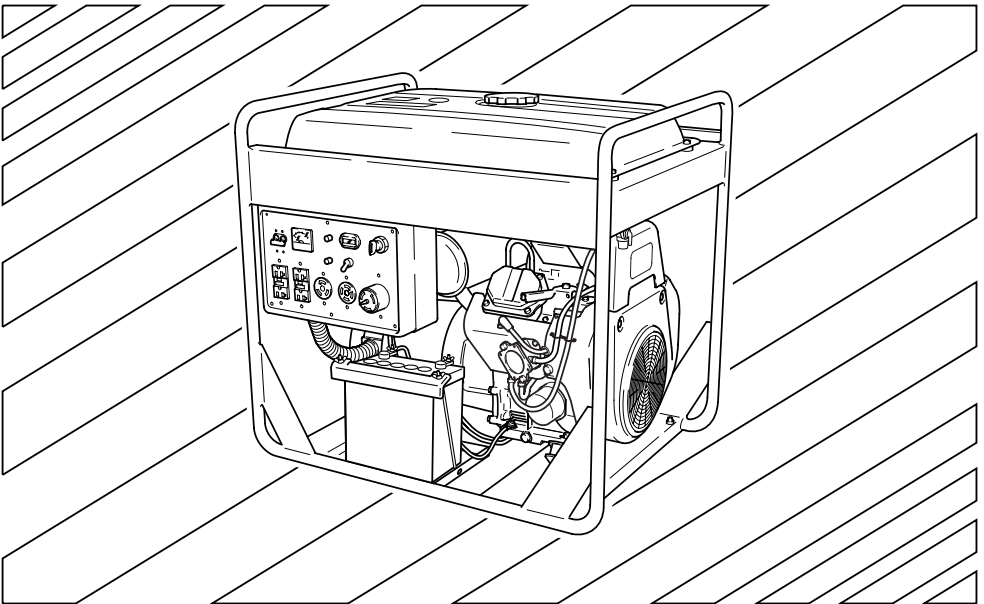

INSTRUCTIONS FOR USE

ISSUE EMD-GU2000

3ZZ9020161



WARNING:



The engine exhaust from this product contains chemicals known to the State of California to cause cancer, birth defects or other reproductive harm.

NOTICE

FEDERAL EMISSION COMPONENT DEFECT WARRANTY and CALIFORNIA EMISSION CONTROL WARRANTY are applicable to only those engines/generators complied with EPA (Environmental Protection Agency) and CARB (California Air Resources Board) emission regulations in the U.S.A.

NOTICE

To the engines/generators exported to and used in the countries other than the U.S.A., warranty service shall be performed by the distributor in each country in accordance with the standard engine/generator warranty policy as applicable.

AIR INDEX

To show compliance with California emission regulations, a hangtag has been provided displaying the Air Index level and durability period of this engine.

The Air Index level defines how clean an engine's exhaust is over a period of time. A bar graph scaled from "0" (most clean) to "10" (least clean) is used to show an engine's Air Index level. A lower Air Index level represents cleaner exhaust from an engine.

The period of time (in hours) that the Air Index level is measured is known as the durability period. Depending on the size of the engine, a selection of time periods can be used to measure the Air Index level (see below).

<u>Descriptive Term</u>	<u>Applicable to Emissions Durability Period</u>
Moderate	- 50 hours (engine from 0 to 80 cc) 125 hours (engine greater than 80 cc)
Intermediate	- 125 hours (engine from 0 to 80 cc) 250 hours (engine greater than 80 cc)
Extended	- 300 hours (engine from 0 to 80 cc) 500 hours (engine greater than 80 cc)

Notice : This hangtag must remain on this engine or piece of equipment, and only be removed by the ultimate purchaser before operation.

FEDERAL EMISSIONS COMPONENT DEFECT WARRANTY

EMISSIONS COMPONENT DEFECT WARRANTY COVERAGE - This emission warranty is applicable in all States, except the State of California

Makita U.S.A. Inc., La Mirada, California, (herein "MAKITA") warrant(s) to the initial retail purchaser and each subsequent owner, that this Nonroad engine (herein "engine") has been designed, built, and equipped to conform at the time of initial sale to all applicable regulations of the U.S. Environmental Protection Agency (EPA), and that the engine is free of defects in materials and workmanship which would cause this engine to fail to conform with EPA regulations during its warranty period.

For the components listed under PARTS COVERED, the Makita Factory Service Center or Service Center authorized by MAKITA will, at no cost to you, make the necessary diagnosis, repair, or replacement necessary to ensure that the engine complies with applicable U.S. EPA regulations.

EMISSION COMPONENT DEFECT WARRANTY PERIOD

The warranty period for this engine begins on the date of sale to the initial purchaser and continues for a period of 2 years.

PARTS COVERED

Listed below are the parts covered by the Emission Components Defect Warranty. Some of the parts listed below may require scheduled maintenance and are warranted up to the first scheduled replacement point for that part.

- | | |
|---|--|
| (1) Fuel Metering System | (3) Ignition System |
| (i) Carburetor and internal parts (and/or pressure regulator or fuel injection system). | (i) Spark plugs. |
| (ii) Air/fuel ratio feedback and control system, if applicable. | (ii) Magneto or electronic ignition system. |
| (iii) Cold start enrichment system, if applicable. | (iii) Spark advance/retard system, if applicable. |
| (iv) Regulator assy (gaseous fuel, if applicable) | (4) Exhaust manifold, if applicable |
| (2) Air Induction System | (5) Miscellaneous Items Used in Above Systems |
| (i) Intake manifold, if applicable | (i) Electronic controls, if applicable |
| (ii) Air filter. | (ii) Hoses, belts, connectors, and assemblies. |
| | (iii) Filter lock assy (gaseous fuel, if applicable) |

OBTAINING WARRANTY SERVICE

To obtain warranty service, take your engine to the nearest Makita Factory Service Center or Service Center authorized by MAKITA. Bring your sales receipts indicating date of purchase for this engine. The Makita Factory Service Center or Service Center authorized by MAKITA will perform the necessary repairs or adjustments within a reasonable amount of time and furnish you with a copy of the repair order. All parts and accessories replaced under this warranty become the property of MAKITA. EPA - MAKITA FEDERAL EMISSIONS COMPONENT DEFECT WARRANTY-continued

WHAT IS NOT COVERED

*Conditions resulting from tampering, misuse, improper adjustment (unless they were made by the Makita Factory Service Center or Service Center authorized by MAKITA during a warranty repair), alteration, accident, failure to use the recommended fuel and oil, or not performing required maintenance services.

- *The replacement parts used for required maintenance services.
- *Consequential damages such as loss of time, inconvenience, loss of use of the engine or equipment, etc.
- *Diagnosis and inspection charges that do not result in warranty-eligible service being performed.
- *Any non-authorized replacement part, or malfunction of authorized parts due to use of non-authorized parts.

OWNER'S WARRANTY RESPONSIBILITIES

As the engine owner, you are responsible for the performance of the required maintenance listed in your owner's manual. MAKITA recommends that you retain all receipts covering maintenance on your engine, but MAKITA cannot deny warranty solely for the lack of receipts or for your failure to ensure the performance of all scheduled maintenance.

As the engine owner, you should however be aware that MAKITA may deny warranty coverage if your engine or a part has failed due to abuse, neglect, improper maintenance or unapproved modifications.

You are responsible for presenting your engine to the nearest Makita Factory Service Center or Service Center authorized by MAKITA when a problem exists.

If you have any questions regarding your warranty rights and responsibilities, you should contact the Makita Warranty Department at 1-800-4-MAKITA for the information.

THINGS YOU SHOULD KNOW ABOUT THE EMISSION CONTROL SYSTEM WARRANTY MAINTENANCE AND REPAIRS

You are responsible for the proper maintenance of the engine. You should keep all receipts and maintenance records covering the performance of regular maintenance in the event questions arise. These receipts and maintenance records should be transferred to each subsequent owner of the engine. MAKITA reserves the right to deny warranty coverage if the engine has not been properly maintained. Warranty claims will not be denied, however, solely because of the lack of required maintenance or failure to keep maintenance records.

MAINTENANCE, REPLACEMENT OR REPAIR OF EMISSION CONTROL DEVICES AND SYSTEMS MAY BE PERFORMED BY ANY REPAIR ESTABLISHMENT OR INDIVIDUAL ; HOWEVER, WARRANTY REPAIRS MUST BE PERFORMED BY THE MAKITA FACTORY SERVICE CENTER OR SERVICE CENTER AUTHORIZED BY MAKITA. THE USE OF PARTS THAT ARE NOT EQUIVALENT IN PERFORMANCE AND DURABILITY TO AUTHORIZED PARTS MAY IMPAIR THE EFFECTIVENESS OF THE EMISSION CONTROL SYSTEM AND MAY HAVE A BEARING ON THE OUTCOME OF A WARRANTY CLAIM.

If other than the parts authorized by MAKITA are used for maintenance replacements or for the repair of components affecting emission control, you should assure yourself that such parts are warranted by their manufacturer to be equivalent to the parts authorized by MAKITA in their performance and durability.

HOW TO MAKE A CLAIM

All repair qualifying under this limited warranty must be performed by a Makita Factory Service Center or Service Center authorized by MAKITA. In the event that any emission-related part is found to be defective during the warranty period, you shall notify Makita Warranty Department at 1-800-4-MAKITA and you will be advised of the appropriate warranty service dealer or service providers where the warranty repair can be performed.

CALIFORNIA EMISSION CONTROL WARRANTY STATEMENT

(This warranty does not apply in any other state.)

YOUR WARRANTY RIGHTS AND OBLIGATIONS

The California Air Resources Board and Makita U.S.A., Inc. (herein "MAKITA") are pleased to explain the emission control warranty on your 2005 and later small off-road engine (herein "engine"). In California, new engine must be designed, built and equipped to meet the State's stringent anti-smog standards. MAKITA must warrant the emission control system on your engine for the periods of time listed below provided there has been no abuse, neglect or improper maintenance of your engine.

Your emission control system includes parts such as the carburetor or fuel injection systems, the ignition system and the catalytic converter. Also included are the hoses, belts, connectors and other emission-related assemblies.

Where a warrantable condition exists, MAKITA will repair your engine at no cost to you including diagnosis, parts and labor.

MANUFACTURER'S WARRANTY COVERAGE :

The 2005 and later engines are warranted for two years. If any emission-related part on your engine is defective, the part will be repaired or replaced by MAKITA.

OWNER'S WARRANTY RESPONSIBILITIES :

- As the engine owner, you are responsible for the performance of the required maintenance listed in your Owner's Manual. MAKITA recommends that you retain all receipts covering maintenance on your engine, but MAKITA cannot deny warranty solely for the lack of receipts or for your failure to ensure the performance of all scheduled maintenance.
- As the engine owner, you should be aware, however, that MAKITA may deny you warranty coverage if your engine or a part has failed due to abuse, neglect, improper maintenance or unapproved modifications.
- You are responsible for presenting your engine to a MAKITA service center as a problem exists.

The warranty repairs should be completed in a reasonable time, not to exceed 30 days.

If you have any questions regarding your warranty rights and responsibilities, you should contact a Makita Factory Service Center Manager nearest you. A list of the Factory Service Center locations and phone numbers is provided below for your convenience.

MAKITA, a distributor of small off-road equipment in the U.S., warrants to the owner of 2005 and later engines that the engine (1) has been designed, built, and equipped at the time of manufacture so as to conform with the applicable regulations of the California Air Resources Board and, (2) is free from defects in materials and workmanship which may cause it to fail to conform with those regulations as applicable according to the terms and conditions stated below.

WARRANTY PERIOD

This warranty period begins on the date which the engine is delivered to the original retail purchaser and ends two years after that date. During this two year period MAKITA warrants to the original retail purchaser and each subsequent purchaser that the engine is free from defect in material and workmanship that can cause the failure of a warranted emission-related part.

WHAT IS COVERED UNDER THIS WARRANTY

Repair and/or replacement of any warranted emission-related part will be performed at no charge provided the work is performed at an authorized warranty station. There will also be no charge for any diagnostic labor performed at an authorized warranty station which leads to the determination that a warranted emission-related part is defective.

Any warranted part which is not scheduled for replacement as required maintenance, or which is scheduled only for regular inspection to the effect of "repair or replace as necessary" shall be warranted for the warranty period. Any warranted part which is scheduled for replacement as required maintenance shall be warranted for the period of time up to the first scheduled replacement of that part. This warranty shall apply only towards the repair, replacement, and/or adjustment of the component parts listed below.

EMISSION-RELATED PARTS COVERED UNDER THIS WARRANTY

(1) Fuel Metering System

- (i) Carburetor and internal parts (and/or pressure regulator or fuel injection system).
- (ii) Air/fuel ratio feedback and control system, if applicable.
- (iii) Cold start enrichment system, if applicable.
- (iv) Regulator assy (gaseous fuel, if applicable)

(2) Air Induction System

- (i) Intake manifold, if applicable
- (ii) Air filter.

(3) Ignition System

- (i) Spark plugs.
- (ii) Magneto or electronic ignition system.
- (iii) Spark advance/retard system, if applicable.

(4) Exhaust manifold, if applicable

(5) Miscellaneous Items Used in Above Systems

- (i) Electronic controls, if applicable
- (ii) Hoses, belts, connectors, and assemblies.
- (iii) Filter lock assy (gaseous fuel, if applicable)

If it is determined by an authorized warranty station that other engine components have been damaged due to the failure of a warranted emission-related part during the warranty period, MAKITA will repair and/or replace the necessary components.

WHAT IS NOT COVERED UNDER THIS WARRANTY

This warranty does not cover any emission-related part which malfunctions, fails, or is damaged due to alterations and/or modifications such as changing, adding, or removing parts.

When an engine is being serviced under warranty, MAKITA and any of its authorized dealers, distributors, or warranty stations shall not be liable for any loss of use of the engine, for any damage to goods, or loss of time or inconvenience. This limited warranty also does not apply to any emission-related part which malfunctions, fails, or is damaged due to failure to follow the maintenance and operating instructions specified in the 2005 and later Owner's Manual including.

- (a) Improper or inadequate maintenance of any warranted emission-related part.
- (b) Improper installation, adjustment, or repair of the engine or any warranted emission-related part unless performed by a factory authorized warranty station.
- (c) Failure to use recommended fuel as specified in the 2005 and later Owner's Manual.
- (d) Repairs and diagnosis performed outside of an authorized warranty station.
- (e) Use of parts which are not authorized by MAKITA.

MAINTENANCE SCHEDULE

The engine owner is responsible for having all scheduled inspection and maintenance services performed at the intervals specified in the 2005 and later Owner's Manual and to retain records of these services as having been performed. These records should be transferred to each subsequent owner of the engine. MAKITA cannot deny a claim solely because there are no records of scheduled maintenance, however, a warranty claim may be denied if the failure to perform the scheduled maintenance and inspection resulted in the failure of a warranted emission-related part.

As a minimum, the engine owner is responsible for the scheduled inspection and maintenance described below which are based on the procedures described in the Owner's Manual.

PROCEDURE	INTERVAL
1) Change engine oil	: Initial 20 hours and every 100 hours afterward
2) Clean air cleaner (element)	: Every 50 hours
3) Replace air cleaner element	: Every 200 hours
4) Clean and adjust spark plug and electrodes	: Every 200 hours

Note: More frequent maintenance may be necessary under dusty, dirty or severe conditions.

REPAIR AND REPLACEMENT OF EMISSION-RELATED PARTS

It is recommended that only engine replacement parts which have been authorized and approved by MAKITA should be used in the performance of any warranty maintenance or repairs of emission-related parts. These replacement parts will be provided at no charge if the part is still under warranty.

HOW TO FILE A WARRANTY CLAIM AND WHERE TO GET WARRANTY SERVICES

Contact the nearest Makita Factory Service Center Manager to determine the appropriate location where the required warranty services are to be performed. A list of the Factory Service Center locations and phone numbers are provided below for your convenience.

41850 Christy Street
Fremont, CA 94538-5107
(510)657-9881

7674 Clairemont Mesa Blvd.
San Diego, CA 92111
(619)278-4471

1421 N. Clovis Ave., Ste. 112
Fresno, CA 93727
(209)252-5166

1714 E. McFadden Ave., Unit M
Santa Ana, CA 92705
(714)667-5066

14930 Northam Street
La Mirada, CA 90638-5753
(714)522-8088

333 Littlefield Ave.
South San Francisco, CA 94080
(415)875-1002

1970 Fulton Avenue
Sacramento, CA 95825
(916)482-5197

16735 Saticoy St., Ste. 105
Van Nuys, CA 91406
(818) 782-2440

1440 South "E" Street
San Bernardino, CA 92408
(909)885-1289

FOREWORD

Thank you for purchasing a Makita generator.

This manual covers operation and maintenance of the Makita generators. All information in this publication is based on the latest production information available at the time of approval for printing.

Pay special attention to statements preceded by the following words:

WARNING

Indicates a strong possibility of severe personal injury, loss of life and equipment damage if instructions are not followed.

[CAUTION]

Indicates a possibility of personal injury or equipment damage if instructions are not followed.

NOTE :

Gives helpful information.

If a problem should arise, or if you have any questions about the generator, consult an authorized dealer or factory service center.

WARNING

- **The generator is designed to give safe and dependable service if operated according to instructions.**
- **Do not operate the generator before you have read and understood the instructions. Failure to do so could result in death, personal injury or equipment damage.**

■ **Check that following accessories come with your Makita Generator.**

- (1) Instruction for use
- (2) Servicing tools
- (3) Battery mounting bracket
(See page 8 and 9.)

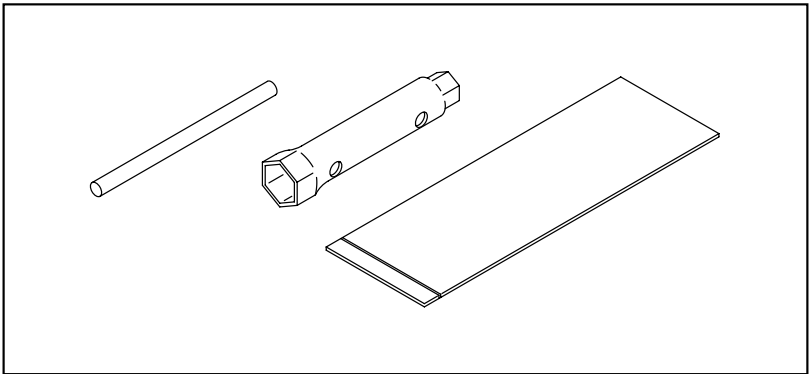



■ **Be sure to replenish with engine oil.**
(See page 6 for details.)

CONTENTS

1. SAFETY PRECAUTIONS	1
2. SPECIFICATIONS	4
3. COMPONENTS	5
4. PRE-OPERATION CHECKS	6
5. OPERATING PROCEDURES	11
6. WATTAGE INFORMATION	21
7. SPARK ARRESTER	23
8. MAINTENANCE SCHEDULE	24
9. "HOW-TO" MAINTENANCE	26
10. PREPARATION FOR STORAGE	30
11. TROUBLESHOOTING	31
12. WIRING DIAGRAM	32

1. SAFETY PRECAUTIONS

 Do not operate the generator near gasoline or gaseous fuel because of the potential danger of explosion or fire.
Do not fill the fuel tank with fuel while the engine is running. Do not smoke or use open flame near the fuel tank. Be careful not to spill fuel during refueling. If fuel is spilt, wipe it off and let dry before starting the engine.





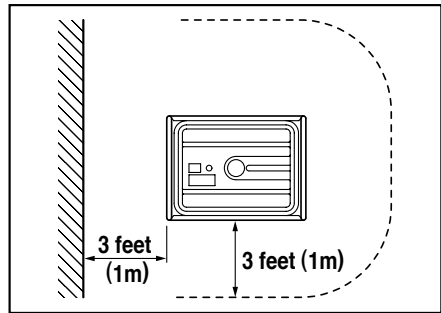

 Do not place inflammables near the generator.
Be careful not to place fuel, matches, gunpowder, oily cloths, straw, trash, or any other inflammables near the generator.

 Do not operate the generator inside a room, cave, tunnel, or other insufficiently ventilated area. Always operate it in a well-ventilated area, otherwise the engine may become overheated, and the poisonous carbon monoxide gas contained in the exhaust gases will endanger human lives. Keep the generator at least 3 feet (1 meter) away from any structure or building during use.





If the generator must be used indoors, the area must be well-ventilated and extreme caution must be taken regarding the discharge of exhaust gases.

 Do not enclose the generator nor cover it with a box.
The generator has a built-in forced air cooling system, and may become overheated if it is enclosed. If generator has been covered to protect it from the weather during non use, be sure to remove it and keep it well away from the area during generator use.

-
-  Operate the generator on a level surface.
It is not necessary to prepare a special foundation for the generator. However, the generator will vibrate on an irregular surface, so choose a level place without surface irregularities.
If the generator is tilted or moved during operation, fuel may spill and/ or the generator may tip over, causing a hazardous situation.
Proper lubrication cannot be expected if the generator is operated on a steep incline or slope. In such a case, piston seizure may occur even if the oil is above the upper level.
-  Pay attention to the wiring or extension cords from the generator to the connected device.
If the wire is under the generator or in contact with a vibrating part, it may break and possibly cause a fire, generator burnout, or electric shock hazard. Replace damaged or worn cords immediately.
-  Do not operate in rain, in wet or damp conditions, or with wet hands.
The operator may suffer severe electric shock if the generator is wet due to rain or snow.
-  If wet, wipe and dry it well before starting. Do not pour water directly over the generator, nor wash it with water.
-  Be extremely careful that all necessary electrical grounding procedures are followed during each and every use. Failure to do so can be fatal.
-  Do not contact the generator to a commercial power line. Connection to a commercial power line may short circuit the generator and ruin it or cause electric shock hazard. Use the transfer switch for connecting to domestic circuit.
-  No smoking while handling the battery. The battery emits flammable hydrogen gas, which can explode if exposed to electric arcing or open flame. Keep the area well-ventilated and keep open flames/sparks away when handling the battery.

 Engine becomes extremely hot during and for some time after operation. Keep combustible materials well away from generator area. Be very careful not to touch any parts of the hot engine especially the muffler area or serious burns may result.

 Keep children and all bystanders at a safe distance from work areas.

 It is absolutely essential that you know the safe and proper use of the power tool or appliance that you intend to use. All operators must read, understand and follow the tool/appliance owners manual. Tool and appliance applications and limitations must be understood. Follow all directions given on labels and warnings. Keep all instruction manuals and literature in a safe place for future reference.

Notes on installation

1. Select a place which allows you to maintain and inspect the generator, which is not exposed to contamination caused by exhaust gas.
If you are planning to install the generator without its wheels attached, consider the work efficiency in terms of an oil change.
2. In ground connection, be sure to use the designated ground terminal.
(A grounding cable is not included in the set of accessories.)
3. During use, be sure not to disconnect the battery.
4. While the power is on, do not unplug the unit or disconnect cables from the terminals.

2. SPECIFICATIONS

Model		G12010R
Alternator	Type	Brush, Self-exciting, 2-pole, Single-phase
	Rated frequency	60 Hz
	Rated voltage	120V / 240V
	Maximum output	12000 W
	Rated output	9500 VA
	Power factor	1.0
	Voltage regulator	A.V.R type
Engine	Model	EH65D
	Type	Twin cylinder, Air-cooled, 4-stroke, Overhead valve engine
	Displacement	653 cm ³
	Fuel	Automotive unleaded gasoline
	Oil capacity	0.41 US-gal (1.55 liters)
	Starting system	Electric starter
Fuel tank capacity		11.38 US-gal (44 liters)
Rated continuous operation per a tankful of fuel	Rated	Approx. 8.2 hours
Dimension	Length	32.5 in. (826 mm)
	Width	24.1 in. (611 mm)
	High	30.4 in. (771 mm)
Dry weight		310.9 lb (141 kg)
Remote controller terminal (Auto choke)		Standard
Valve Clearance (Intake & Exhaust)		0.0039±0.0008 in. (0.1±0.02 mm) Note : Adjust the valve clearance while the engine is cold.
Emissions Durability Period (California only)		500 hours

3. COMPONENTS

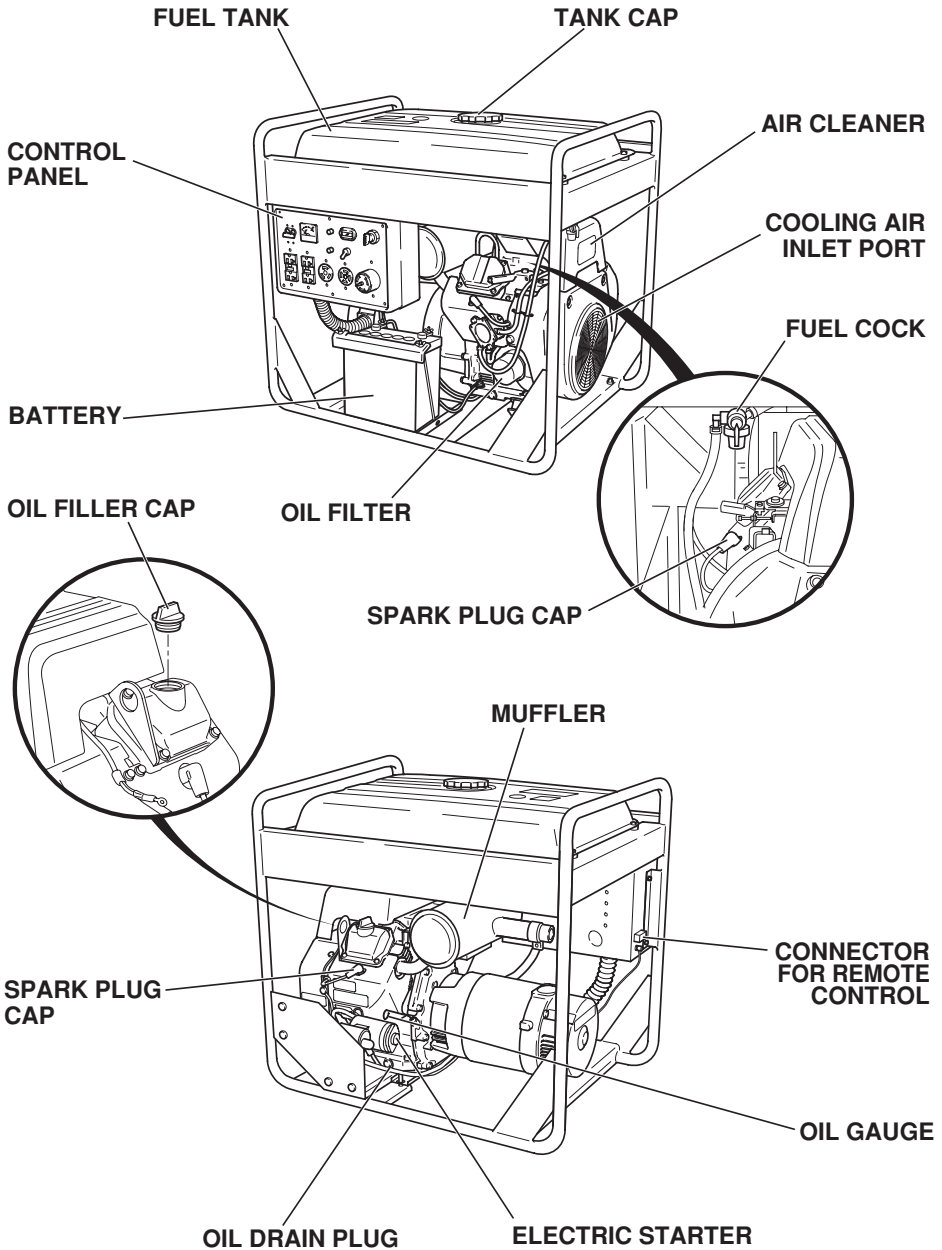

4. PRE-OPERATION CHECK

CHECK ENGINE OIL

Before checking or refilling oil, be sure generator is located on stable and level surface with engine stopped.

- 1) Remove oil level gauge and check the engine oil level.
- 2) If oil level is below the lower level "L" refill with suitable oil (see table) to upper level "F" after removing the engine oil filler cap.
- 3) Change oil if contaminated.
(See "How-To" Maintenance.)

Oil capacity 0.41 US-gal (Upper level)
1.55 liters (Upper level)

NOTE :

- The engine is equipped with an oil sensor unit (hydraulic pressure detection type) that will automatically stop the engine if oil in the crank case is reduced below the specified level. Should the engine be automatically stopped, be sure to check the amounts of fuel and oil.
- When the oil is reduced below the specified level, add new oil to the upper limit. Since the oil sensor will not detect the deterioration of oil, visually check the quality or determine it by the specified time and then change the oil if necessary. (Refer to page 25.)

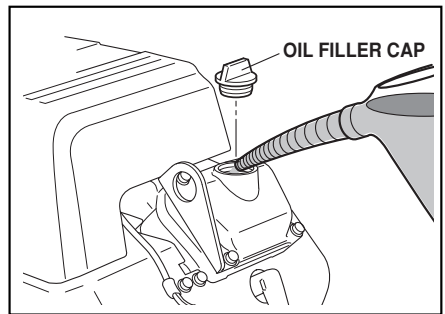
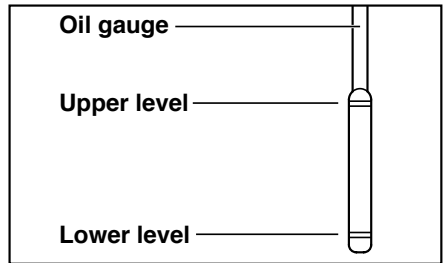
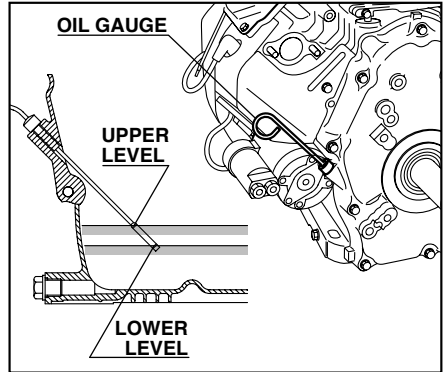

Recommended engine oil :

Use 4-stroke automotive detergent oil of API service class **SE** or higher grade (**SG**, **SH** or **SJ** is recommended). **SAE 10W-30** or **10W-40** is recommended for general, all-temperature use. If single viscosity oil is used, select the appropriate viscosity for the average temperature in your area.

Single grade	5W						
	10W						
Multigrade	10W-30						
	10W-40						
Ambient temperature	-20	-10	0	10	20	30	40°C
	-4	14	32	50	68	86	104°F

CHECK ENGINE FUEL

⚠ WARNING

Do not refuel while smoking or near open flame or other such potential fire hazards. Otherwise fire accident may occur.

- 1) Check fuel level at fuel level gauge.
- 2) If fuel level is low, refill with automotive unleaded gasoline only.
This engine is certified to operate on automotive unleaded gasoline.
- 3) Be sure to use the fuel filter screen on the fuel filter neck.

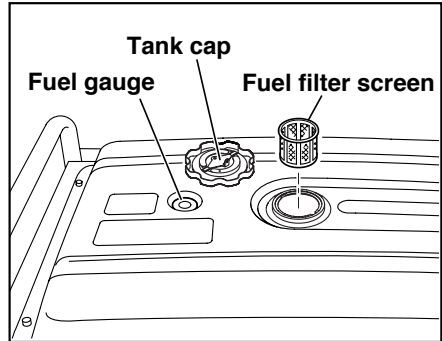

Recommended fuel :

Unleaded automotive gasoline of octane rating RON87 or higher.

Fuel tank capacity :

11.38 US-gal (44 liters)

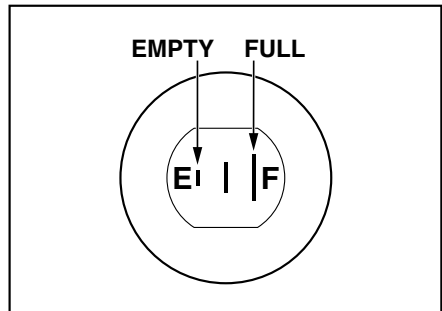

NOTE :

- The full level of fuel is the upper surface of the fuel filter.

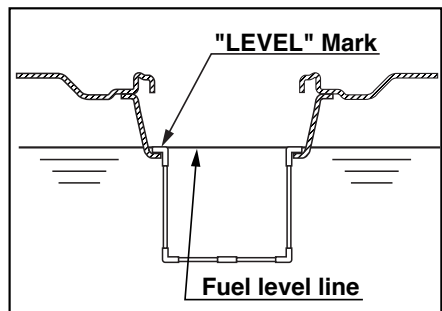

Continuous operation time in normal use (rated load)	
G12010R	Approx. 8.2 hours

⚠ WARNING

Make sure you review each warning in order to prevent fire hazard.

- Do not refill tank while engine is running or hot.
- Close fuel cock before refueling with fuel.
- Be careful not to admit dust, dirt, water or other foreign objects into fuel.
- Do not fill above the top of the fuel filter (marked "LEVEL") or the fuel may overflow when it heats up later and expands.
- Wipe off spilt fuel thoroughly before starting engine.
- Keep open flames away.

BATTERY INSTALLATION

Recommended Battery

Lead-acid battery : A capacity of 12V-32A·h or larger.

For the generators used in low temperature (below -5°C),
12V-40A·h or larger battery is recommended.

- 1) Attach terminals to a lead-acid battery already charged. Mount the battery onto the position as specified below, with its terminals facing inward.
- 2) Insert each long bolt through the specified hole, its tip pointing outward.
- 3) Put the supporting arm on the long bolts and tighten with the butterfly nuts. (Push the lead-acid battery all the way inward.)
- 4) Arrange the wiring so that it won't be damaged by possible vibration caused by the engine.
- 5) Only after checking that the engine's starter key is in the "OFF" position, securely connect the red cable, to the positive (+) terminal. And then connect the other cable to the negative (-) terminal.

Red cable : to the (+) terminal

Black cable : to the (-) terminal

[CAUTION]

Should the connection be made in incorrect manner, the engine will be broken.

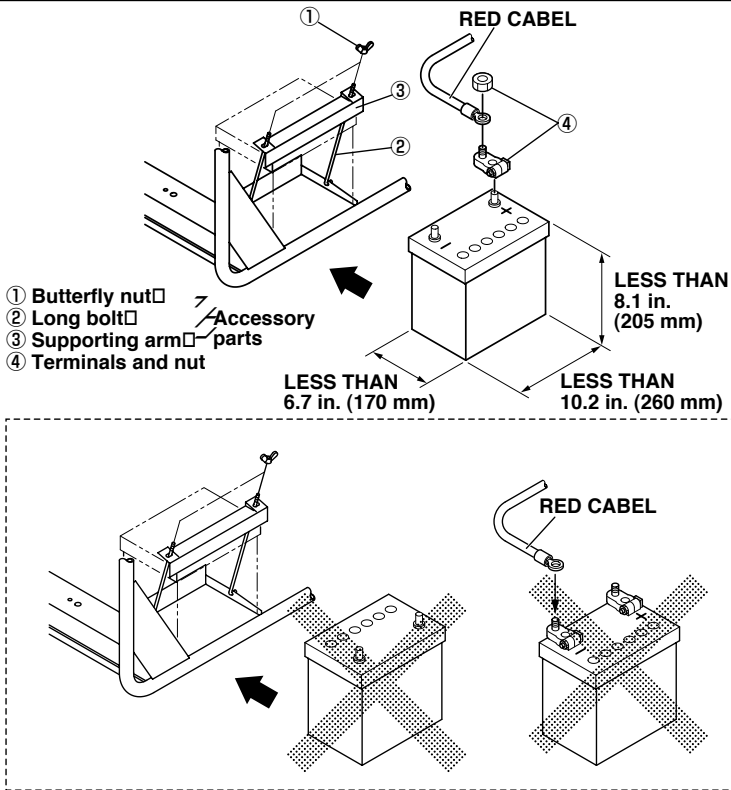

⚠ WARNING

Death, personal injury and/ or property damage may occur unless instructions are followed carefully.

- Disconnect battery cables when charging battery.
- Use battery of specified capacity listed in the owner's manual.
- Turn the starter switch to the "STOP" position when mounting or dismantling battery. Connect positive (+) terminal first when mounting battery, and disconnect negative (-) terminal first when dismantling.

RED CABLE : To positive (+) terminal

BLACK CABLE : To negative (-) terminal

CHECK COMPONENT PARTS

Check following items before starting engine:

- Fuel leakage from fuel hose, etc.
- Bolts and nuts for looseness.
- Components for damage or breakage.
- Generator not resting on or against any adjacent wiring.

CHECK GENERATOR SURROUNDINGS

WARNING

Make sure you review each warning in order to prevent fire hazard.

- **Keep area clear of inflammables or other hazardous materials.**
- **Keep generator at least 3 feet (1 meter) away from buildings or other structures.**
- **Only operate generator in a dry, well ventilated area.**
- **Keep exhaust pipe clear of foreign objects.**
- **Keep generator away from open flame. No smoking!**
- **Keep generator on a stable and level surface.**
- **Do not block generator air vents with paper or other material.**

5. OPERATING PROCEDURES

STARTING THE ENGINE

[CAUTION]

- Check the oil level before each operations. (See page 6)
- Perform the specified Daily Inspection to see if it is in normal condition.

(1) Make sure that the no-fuse breaker is off.

(2) Turn the fuel cock to the vertical (open) position

(3) Turn the key switch to the "START" position.

If the engine won't start, turn the switch back to "RUN" position and then wait for approximately 10 seconds to try it again.

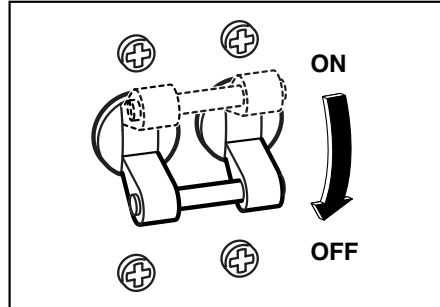

NOTE :

- You might have to keep the starter running for at least 3 to 5 seconds, since the engine incorporates the mechanism in it where the ignition circuit is activated by the increase of hydraulic pressure.

- In the following occasion, two or three trials may be required for starting the engine :

(1) The very first starting of a new generator.

(2) After the refueling of the engine which has been stopped due to fuel shortage.

(3) Starting after the oil filter change.

(4) Warm the engine up for a minute or two. Longer time would be needed in cold weather.

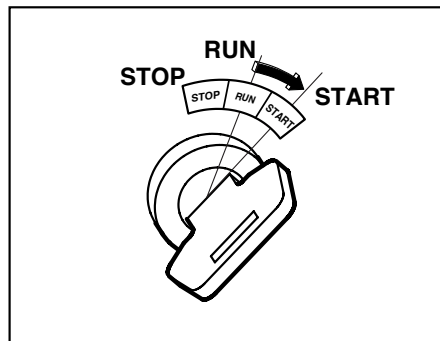
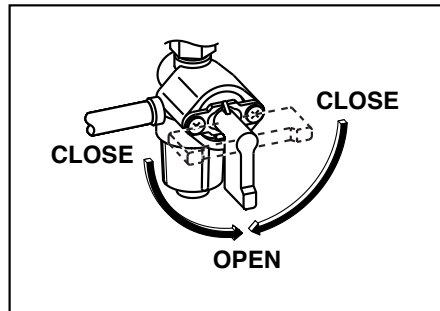

USING ELECTRIC POWER

⚠ WARNING

- Make sure that the appliance is switched OFF before connecting it to the generator.
- Do not move the generator while it is running.
- Be sure to ground the generator if the connected appliance is grounded. Failure to ground unit may lead to electrical shock.

CONTROL PANEL

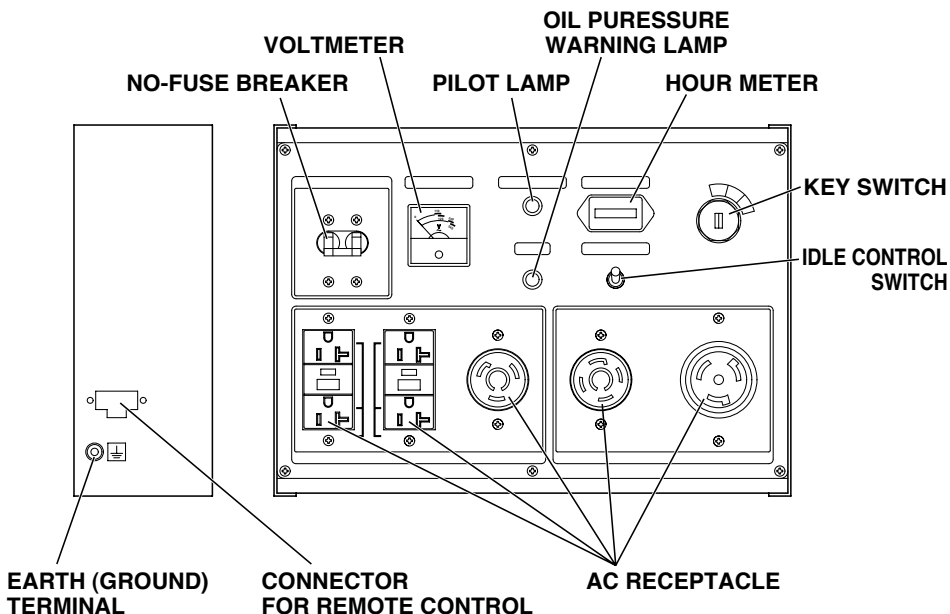

(1) AC APPLICATION

- (a) Ground the generator, using the ground terminal located at the side of the panel.
- (b) Before starting the engine, check that the no-fuse breaker of the generator and the power switches of the appliances are turned off.
- (c) Connect the plugs of the appliances to the receptacles before starting the engine. If you wish to use for a long period of time, connecting to the output terminal is recommended.
- (d) Start the engine and check that the voltage meter is indicating correct voltage.

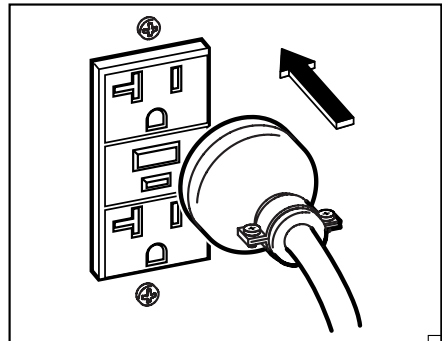
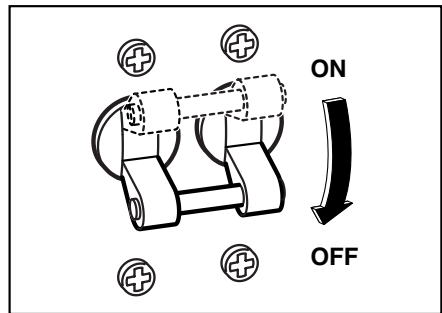
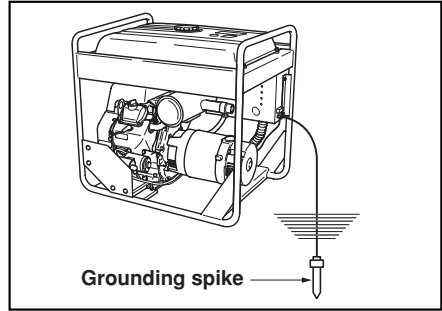

- Check the amperage of the receptacles used referring to **TABLE 1**, and be sure not to take a current exceeding the specified amperage.
- Be sure that the total wattage of all appliances dose not exceed the rated output of the generator.





Style	Ampere	Receptacle	AC plug	Description
	up to 20A	NEMA 5-20R	NEMA 5-20P	GFCI (Ground Fault Circuit Interrupter) Receptacle, duplex (REC1)
	up to 30A	NEMA L5-30R	NEMA L5-30P	Locking Receptacle (REC2)
	up to 30A	NEMA L14-30R	NEMA L14-30P	Locking Receptacle (REC3)
	up to 50A	Locking Receptacle (REC4)		

TABLE 1

⚠ WARNING

- To take power out from the **TWIST LOCK RECEPTACLE**, insert the plug into the receptacle, and turn it clockwise to the lock position.
- Be sure to ground the generator if the connected electrical device is grounded.

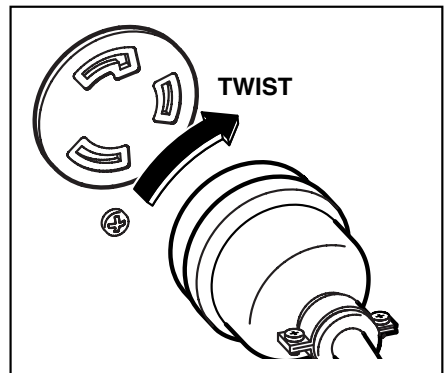

NOTE :

When the no-fuse breaker turns off during operation, the generator is over loaded or the appliance is defective. Stop the generator immediately, check the appliance and / or generator for overloading or detect and have repaired as necessary by Makita dealer or service shop.

[CAUTION]

The duplex 120V receptacle is protected by a GFCI (Ground Fault Circuit Interrupter). GFCI shuts off the output current from the duplex 120V receptacle when a ground fault occurs in the generator or the appliance. Please note that other receptacles are not protected by GFCI.

GFCI RECEPTACLE

After starting the engine, check the GFCI for proper functioning by the following test procedure.

- Push blue TEST button, The red RESET button will pop out exposing the word TRIP. Power is now off at the outlets protected by the GFCI, indicating that the device is functioning properly.
- If TRIP dose not appear when testing, do not use the generator. Call a qualified electrician.
- To restore power, push RESET button.

WARNING

If the RESET button pops out during operation, stop the generator immediately and call a qualified electrician for checking generator and the appliances.

(2) CONNECTING TO DOMESTIC CIRCUIT (HOUSE WIRING)

WARNING

This generator is neutral grounded type.

If a generator is to be connected to residential or commercial power lines, such as a stand-by power source during power outage, all connections must be made by a licensed electrician.

Failure in connection may result in death, personal injury, damage to generator, damage to appliances, damage to the building's wiring or fire.

(a) When connecting a Makita generator to a house wiring, generator output power must be taken from the 240V-4P receptacle.

(b) Install a transfer switch.

A transfer switch must be installed to transfer the load from the commercial power source to the generator. This switch is necessary to prevent accidents caused by the recovery from power outage. Use a transfer switch of the correct capacity.

Install transfer switch between the meter and the fuse or AC breaker box.

[CAUTION]

If the neutral wire of house wiring is grounded, be sure to ground the ground terminal of the generator, Otherwise an electric shock may occur to the operator.

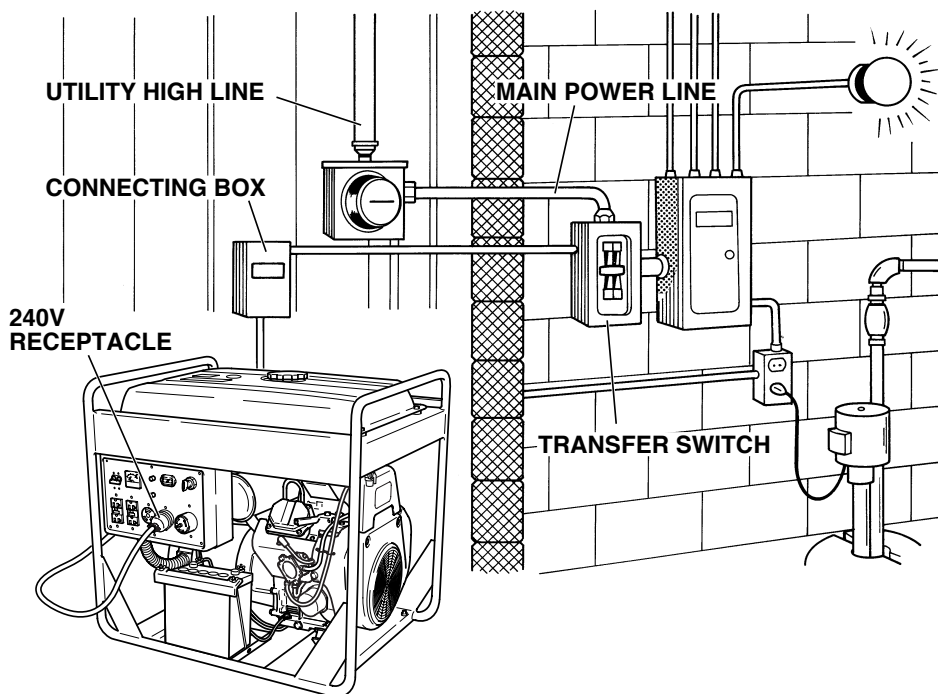

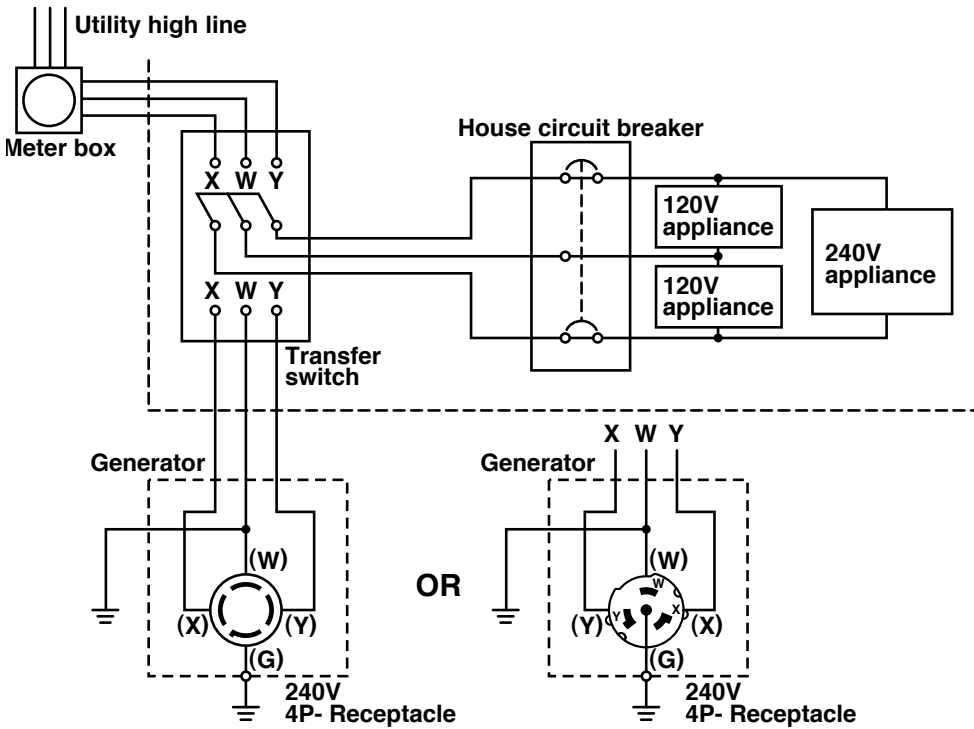

(c) Operating the generator.

- Set the full power switch to 120V/240V side.
- Turn the house AC breaker off before starting the generator.
- Start the generator and warm it up.
- Turn the house AC breaker on.

[CAUTION]

Do not start the generator with electrical appliance (s) connected and with their switches on.

Otherwise the appliance (s) may be damaged by the surge voltage at starting.

NOTE :

When the no-fuse breaker turns off during operation, the generator is over loaded or the appliance is defective. Stop the generator immediately, check the appliance and / or generator for overloading or detect and have repaired as necessary by Makita dealer or service shop.

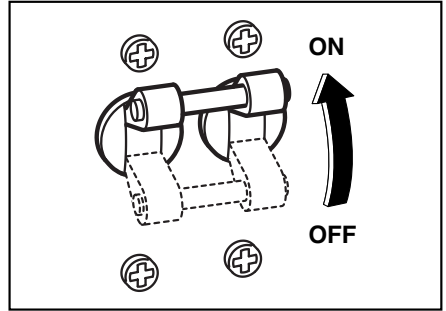

(d) Turn the breaker on to see if the pilot lamp lights up.

(e) Turn on the switch of the appliance.

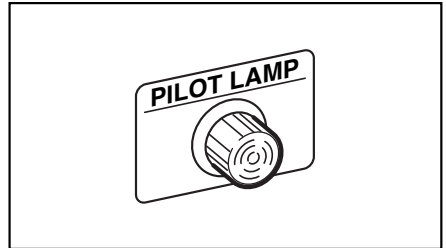

(3) IDLE CONTROL SWITCH

IDLE CONTROL SWITCH automatically reduces engine speed when load is OFF, and automatically increases engine speed to rated r.p.m. when load is ON.

IDLE CONTROL SWITCH provides fuel economy and low noise operation at no-load running.

(1) HOW TO USE IDLE CONTROL SWITCH

- Start the engine with IDLE CONTROL SWITCH off.

NOTE :

Warm up the engine without a load for a few minutes.

- Turn IDLE CONTROL SWITCH on.

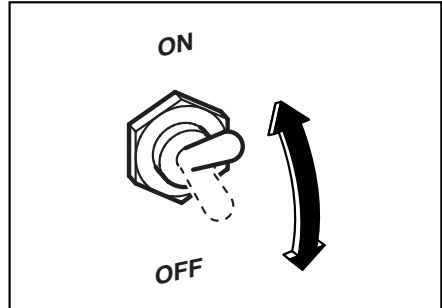

(2) CHECKING THE OPERATION

When IDLE CONTROL SWITCH does not operate normally, please check following :

- Overloaded ?

Please make it sure that the generator is not overload.

NOTE :

Most induction loads such as electric motors require three to five times more wattage than their ratings during starting.

This starting wattage should not exceed the rated output of the generator for proper operation of IDLE CONTROL SWITCH.

- Turn IDLE CONTROL SWITCH off when the IDLE CONTROL SWITCH does not work normally under the rated output.

NOTE :

The IDLE CONTROL SWITCH may not operate when the applied load is under 40W. In such cases turn the IDLE CONTROL SWITCH off.

STOPPING THE GENERATOR

- (1) Turn off the power switch of the electric equipment.
- (2) Turn the no-fuse breaker to off.
- (3) Unplug the cord from receptacle of the generator.

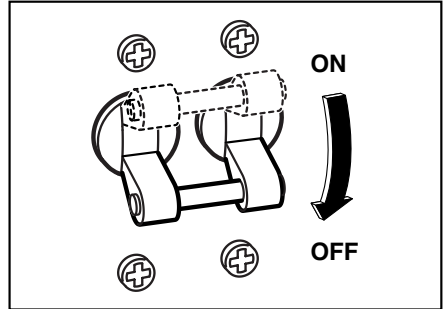

- (4) Allow the engine to run at no-load for about 3 minutes to cool down before stopping.
- (5) Turn the key switch to the STOP position.

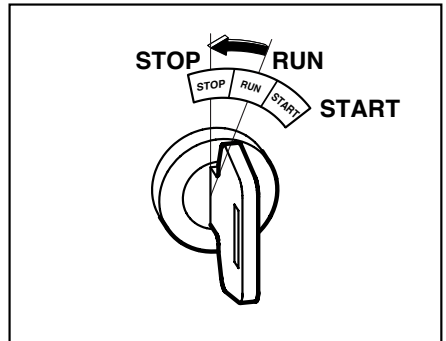

- (6) Close the fuel cock.

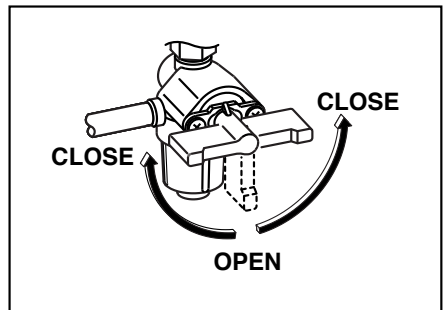

6. WATTAGE INFORMATION

Some appliances need a "surge" of energy when starting.

This means that the amount of electrical power needed to start the appliance may exceed the amount needed to maintain its use.

Electrical appliances and tools normally come with a label indicating voltage, cycles/Hz, amperage (amps) and electrical power needed to run the appliance or tool.

Check with your nearest dealer or service center with questions regarding power surge of certain appliances or power tools.

- Electrical loads such as incandescent lamps and hot plates require the same wattage to start as is needed to maintain use.
- Loads such as fluorescent lamps require 1.2 to 2 times the indicated wattage during start-up.
- Loads for mercury lamps require 2 to 3 times the indicated wattage during start-up.
- Electrical motors require a large starting current. Power requirements depend on the type of motor and its use. Once enough "surge" is attained to start the motor, the appliance will require only 50% to 30% of the wattage to continue running.
- Most electrical tools require 1.2 to 3 times their wattage for running under load during use. (For example, a 9,000 watt generator can power a 3,200 to 7,000 watt electrical tool.)
- Loads such as submersible pumps, air conditioners and air compressors require a very large force to start. They need 3 to 5 times the normal running wattage in order to start. (For example, a 5,000 watt generator would only be able to drive a 1,800 to 3,100 watt pump.)
- If the power consumption of electrical appliances exceeds the operating range or if there is short circuit or other problems in the appliances, the AC breaker could trip "OFF" or the rotation of the generator could be abnormally reduced. In this case, stop the generator to see if the power consumption of the appliances is too large and if there is a problem in the appliances.
- The frequency (the number of the generators rotation) was adjusted before the time of shipment. Changing the frequency could result in the generators breakdown, so refrain from changing it.

To determine the total wattage required to run a particular electrical appliance or tool, multiply the voltage figure of the appliance/tool by the amperage (amps) figure of same. The voltage and amperage (amps) information can be found on a name plate which is normally attached to electrical appliances and tools.

Applications	Applicable Wattage (W)	
	G12010R	
	60 Hz	
Incandescent lamp, Heater	9,500	
Fluorescent lamp, Electric tool	4,700	
Pump, Compressor	2,400	

NOTE :

- The above wattage chart is general guide only. Refer to your specific appliance for correct wattage.
- When you use two or more alternating current outlets at a time, be careful that the sum of the appliances' power consumption does not exceed the value specified in the above chart.

VOLTAGE DROP IN ELECTRIC EXTENSION CORDS

When a long electric extension cord is used to connect an appliance or tool with the generator, a certain amount of voltage drop occurs in the extension cord which lessens the effective voltage available to the appliance or tool.

The chart below has been prepared to illustrate the approximate voltage loss when an extension cord of 300 feet (approx. 100 meters) is used to connect an appliance or tool to the generator.

Nominal cross section	A.W.G.	Allowable current	No.of strands / strands dia.	Resistance	Current Amp.							Voltage drop
					1A	3A	5A	8A	10A	12A	15A	
mm ²	No.	A	No./mm	Ω/100m	1A	3A	5A	8A	10A	12A	15A	
0.75	18	7	30/0.18	2.477	2.5V	8V	12.5V	—	—	—	—	
1.27	16	12	50/0.16	1.486	1.5V	5V	7.5V	12V	15V	18V	—	
2.0	14	17	37/0.26	0.952	1V	3V	5V	8V	10V	12V	15V	
3.5	12 to 10	23	45/0.32	0.517	—	1.5V	2.5V	4V	5V	6.5V	7.5V	
5.5	10 to 8	35	70/0.32	0.332	—	1V	2V	2.5V	3.5V	4V	5V	

7. SPARK ARRESTER

SPARK ARRESTER

In a dry or wooded area, it is recommendable to use the product with a spark arrester. Some areas require the use of a spark arrester. Please check your local laws and regulations before operating your product.

The spark arrester must be cleaned regularly to keep it functioning as designed. A clogged spark arrester :

- Prevents the flow of exhaust gas
- Reduces engine output
- Increases fuel consumption
- Makes starting difficult

If the engine has been running, the muffler and the spark arrester will be very hot. Allow the muffler to cool before cleaning the spark arrester.

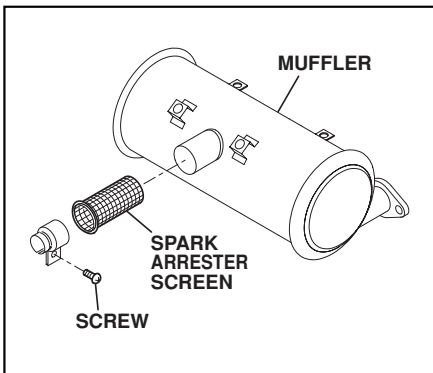

How to remove the spark arrester

1. Remove the flange bolts from the muffler cover and remove the muffler cover.
2. Remove the special screw from the spark arrester and remove the spark arrester from the muffler.

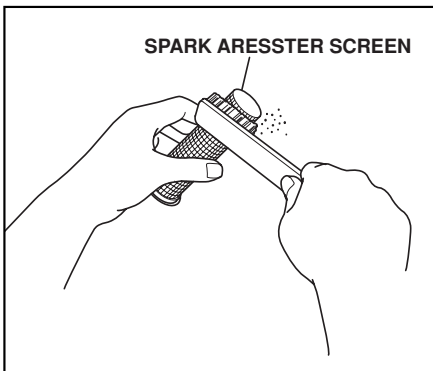

Clean the spark arrester screen

Use a brush to remove carbon deposits from the spark arrester screen. Be careful to avoid damaging the screen.

The spark arrester must be free of breaks and holes. Replace the spark arrester if it is damaged.

Install the spark arrester, and muffler protector in the reverse order of disassembly.

8. MAINTENANCE SCHEDULE

MAINTENANCE, REPLACEMENT OR REPAIR OF THE EMISSION CONTROL DEVICES AND SYSTEMS MAY BE PERFORMED BY ANY NONROAD ENGINE REPAIR ESTABLISHMENT OR INDIVIDUAL.

DAILY INSPECTION

Before running the generator, check the following service items:

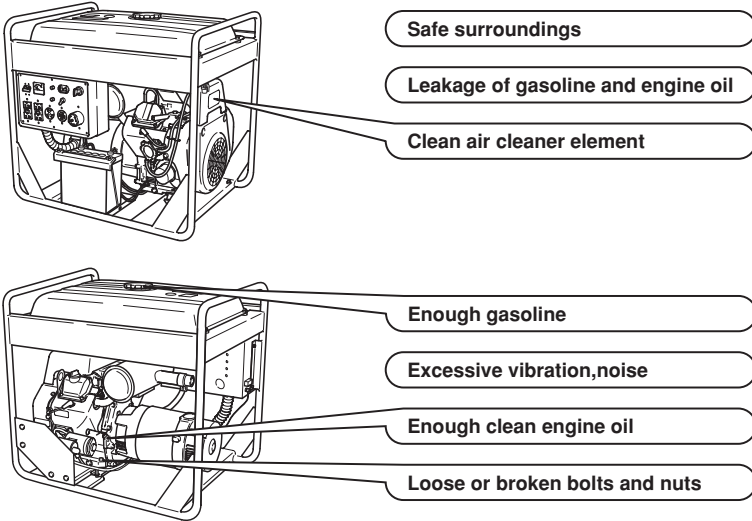

PERIODIC MAINTENANCE

Periodic maintenance is vital to safe and efficient operation of your generator. Check the table below for periodic maintenance intervals.

IT IS ALSO NECESSARY FOR THE USER OF THIS GENERATOR TO CONDUCT THE MAINTENANCE AND ADJUSTMENTS ON THE EMISSION-RELATED PARTS LISTED BELOW TO KEEP THE EMISSION CONTROL SYSTEM EFFECTIVE.

The emission control system consists of the following parts :

- | | | |
|---|--|--|
| (1) Carburetor and internal parts | (4) Air cleaner elements | (8) Exhaust manifold, if applicable |
| (2) Cold start enrichment system, if applicable | (5) Spark plug | (9) Hoses, belts, connectors, and assemblies |
| (3) Intake manifold, if applicable | (6) Magneto or electronic ignition system | |
| | (7) Spark advance/retard system, if applicable | |

The maintenance schedule indicated in the table is based on the normal generator operation. Should the generator be operated in extremely dusty condition or in heavier loading condition, the maintenance intervals must be shortened depending on the contamination of oil, clogging of filter elements, wear of parts, and so on.

(Periodic Maintenance Schedule table)

Maintenance Items	Every 8 hours (Daily)	Every 20 hours	Every 50 hours	Every 200 hours	Every 500 hours	Every 1000 hours
Clean generator and check bolts and nuts	● (Daily)					
Check and refill engine oil	● (Refill daily to upper level)					
Change engine oil (*Note 1)		● (Initial)	● (Every 100 hours)			
Replace engine oil filter (*Note 1)		● (Initial)		●		
Check battery electrolyte fluid level			●			
Clean spark plug			●			
Clean air cleaner			●			
Replace air cleaner element				●		
Clean fuel strainer				●		
Clean and adjust spark plug and electrodes				●		
Replace spark plug					●	
Spark arrester			● (Every 100 hours)			
Remove carbon from cylinder head					●	
Clean and adjust carburetor					●	
Clean engine base (oil pan)					●	
Check and adjust valve clearance					●	
Check and replace carbon brushes					●	
Replace fuel lines						● (Yearly)
Overhaul engine (*Note 2)						●

*Note 1 : Initial oil change should be performed after first twenty (20) hours of operation. Thereafter change oil every hundred (100) hours. Before changing oil, check for a suitable way to dispose of old oil. Do not pour it down into sewage drains, onto garden soil or into open streams. Your local zoning or environmental regulations will give you more detailed instructions on proper disposal.

*Note 2 : As to the procedures for these items, please refer to the SERVICE MANUAL or consult your nearest Makita service dealer.

*Note 3 : More frequent oil changing, oil filter replacement and air cleaner service on replacement may be necessary depending on operating conditions. This would include dusty environment, high ambient temperature, heavy engine loading.

9. "HOW-TO" MAINTENANCE

ENGINE OIL CHANGE

- Initial oil change
 - · · · · After 20 hours of operation
 - Thereafter
 - · · · · Every 100 hours of operation
1. When changing oil, stop the engine and loosen the drain plug.
 2. Re-install the drain plug before refilling oil.
 3. Refer to the recommended oil table on page 6.
 4. Always use the best grade and clean oil. Contaminated oil, poor quality oil and shortage of oil cause damage to engine or shorten the engine life.

Oil capacity · · · · · 0.41 US-gal (Upper level)
1.55 liters (Upper level)

ENGINE OIL FILTER REPLACEMENT

- Initial engine oil filter replacement should be performed after 20 hours of operation. Thereafter replace the engine oil filter every 200 hours.
- When installing a new oil filter, apply oil to O-ring, attach the oil filter in position and tighten 2/3 turns by hand or with wrench after touching the O-ring to the sealing surface of engine.
- Run the engine for a minute ; stop the engine and check for oil leakage around the oil filter and recheck the oil level.

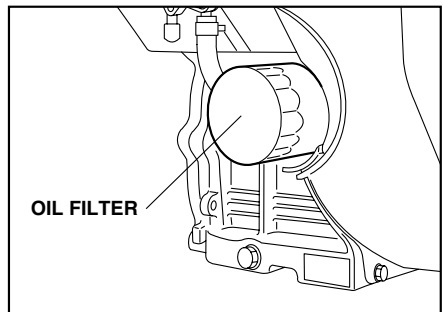
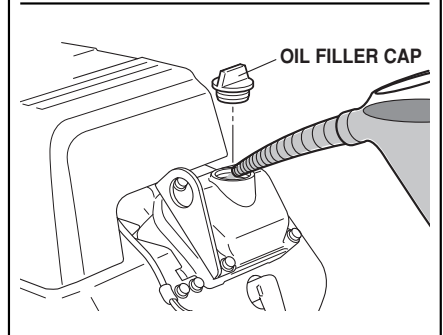
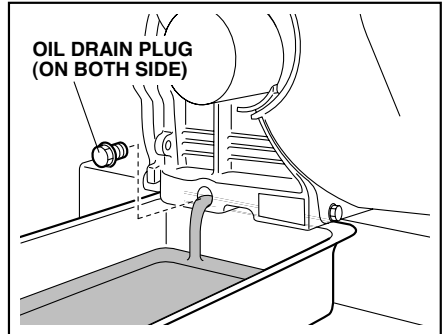

CAUTION

To prevent injury, pay attention to the spilled hot engine oil when replacing engine oil filter.

SERVICING AIR CLEANER

A dirty air cleaner element will cause starting difficulty, power loss, engine malfunctions, and shorten engine life extremely.

Always keep the air cleaner element clean. Replace the air cleaner element set more often in dusty environments.

The air cleaner paper inner element and urethane foam outer element can be removed after removing knob and air cleaner cover. When installing, set the paper element and urethane foam on the air cleaner base. Check that the grommet is in position, and then install the cover with knob tightened securely.

■ Urethane Foam cleaning

Wash and clean the urethane foam in kerosene. Saturate in a mixture of 3 parts kerosene and 1 part engine oil, and then squeeze to remove excess oil.

Clean or replace the urethane foam element every 50 hours. (more often in dusty environments)

■ Paper element

Clean by tapping gently to remove dirt and blow off dust. Never use oil.

Clean or replace the paper element every 50 hours of operation, and replace element set every 200 hours.

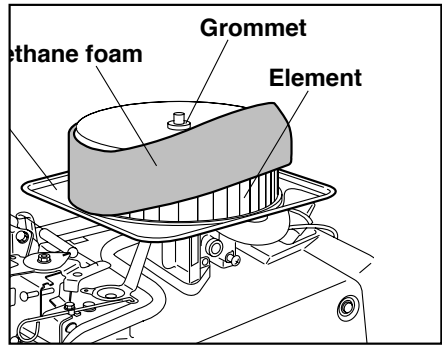
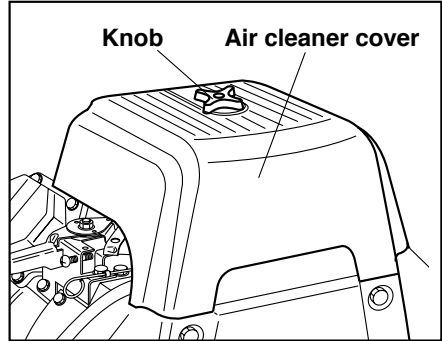

CLEANING AND ADJUSTING SPARK PLUG

- (a) Unplug the high-voltage cables (located at the outlet panel and lead-acid battery).
- (b) Using the supplied plug wrench and handle, turn it counterclockwise until it comes off.
- (c) Clean the area around the mounting hole.

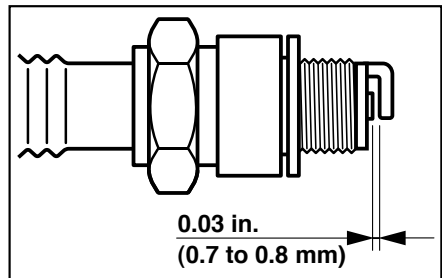

- (d) Clean the electrodes if they are dirty. Adjust the clearance to 0.03 in. (0.7-0.8 mm). Replace it with a new one if the abrasion has developed to the degree where a flat surface cannot be obtained on its projection. If the electrodes turn black, also inspect the air cleaner.
- (e) Attach and tighten the plug with the specified torque : 25 to 30 Nm (2.5 to 3.0 kg-m).
- (f) After checking that the contact area inside the plug cap is not corroded, connect the high-voltage cables.

Spark plug
NGK BPR5ES (CHAMPION RN11YC)

CLEANING FUEL STRAINER

Dirt and water in the fuel are removed by the fuel strainer.

- (a) Remove the strainer cup and throw away water and dirt.
- (b) Clean the screen and strainer cup with gasoline.
- (c) Tightly fasten the cup to main body, making sure to avoid fuel leak.

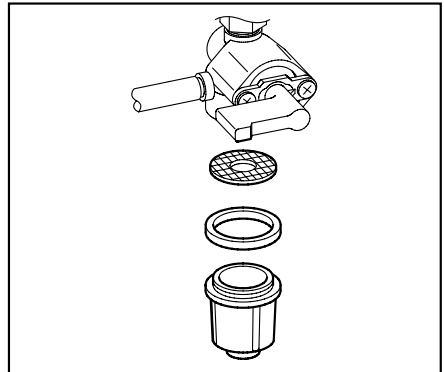

FUEL HOSE REPLACEMENT

WARNING

Take extreme caution when replacing fuel hose ; gasoline is flammable.

Replace the fuel hose every 1,000 hours or every year.

If fuel hose leak is found, replace the fuel hose immediately.

CHECKING CARBON BRUSH

If the brush become excessively worn, its contact pressure with the slip ring changes and causes a roughened surface on the slip ring, resulting in irregular generator performance.

Check the brush every 500 hours or if generator performance is irregular.

If the brush is 0.2 in.(5 mm) long or less, replace it with a new one.

- (a) Remove the brush cover.
- (b) Disconnect the wire connector and remove the brush.
- (c) Carefully note the brush direction and relative position with the slip ring when installing new brush.

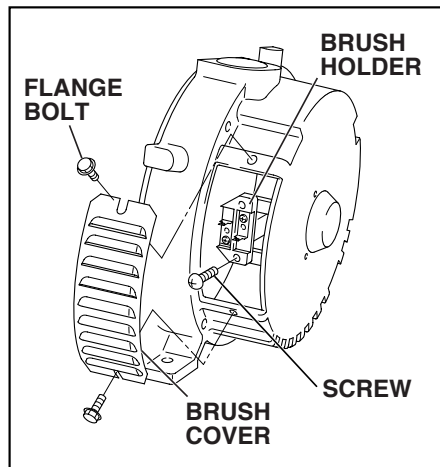
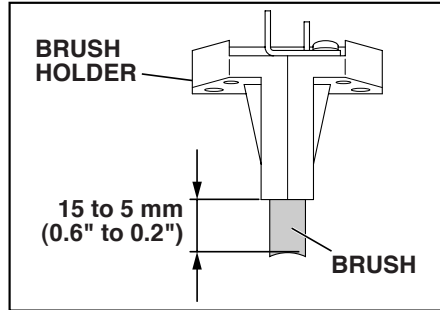

10. PREPARATION FOR STORAGE

The following procedures should be followed prior to storage of your generator for a period of 6 months or longer.

- Drain fuel from fuel tank and strainer (cup) carefully by disconnecting the fuel line. Gasoline left in the fuel tank will eventually deteriorate making engine-starting difficult.
- In order to remove the fuel in the carburetor, run the engine at no-load until it stops.
- Disconnect the terminal of the battery.
- Change engine oil.
- Check for loose bolts and screws, tighten them if necessary.
- Clean generator thoroughly with oiled cloth. Spray with preservative if available. **NEVER USE WATER TO CLEAN GENERATOR !**
- Store generator in a well ventilated, low humidity area.

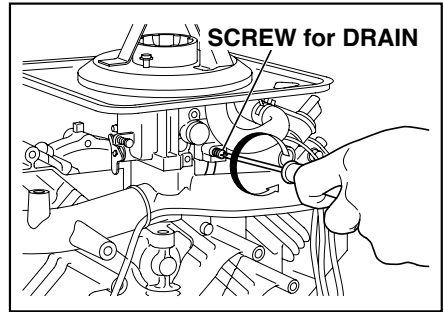

11. TROUBLESHOOTING

When generator engine fails to start after several attempts, or if no electricity is available at the output receptacles, check the possible causes in accordance with the following table. If your generator still fails to start or generate electricity, contact your nearest Makita dealer or authorized service center for further information or corrective procedures.

Problem		Possible causes												
		Low battery	Blown fuse	Deteriorated fuel	Fuel piping		Clogging of Air cleaner	Clogging of Cooling air intake	Low oil level	Faulty spark plug	Overload by connected appliance	Incorrect or poor connection of wires	Insufficient capacity of extension cable	Carbon brushes are excessively worn
Starter won't run		×	×											
Starter runs, but Engine won't start.				×	×	×		×	×					
During operation	Rotation decreased			×	×	×	×	×	×	×				
	Unstable rotation			×	×	×	×		×					
	Breaker turned off									×	×			
	Low power			×	×	×	×		×	×	×	×	×	×

12. WIRING DIAGRAM

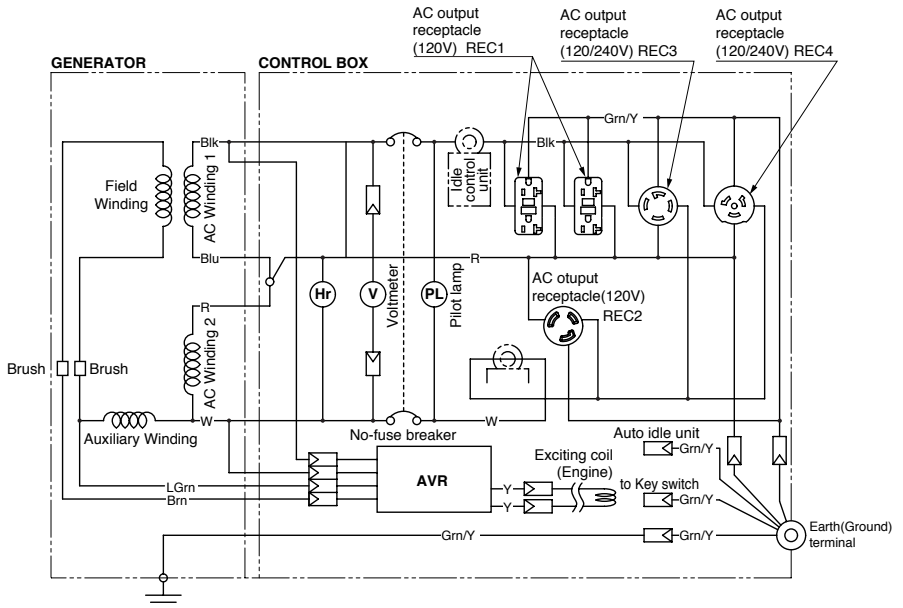
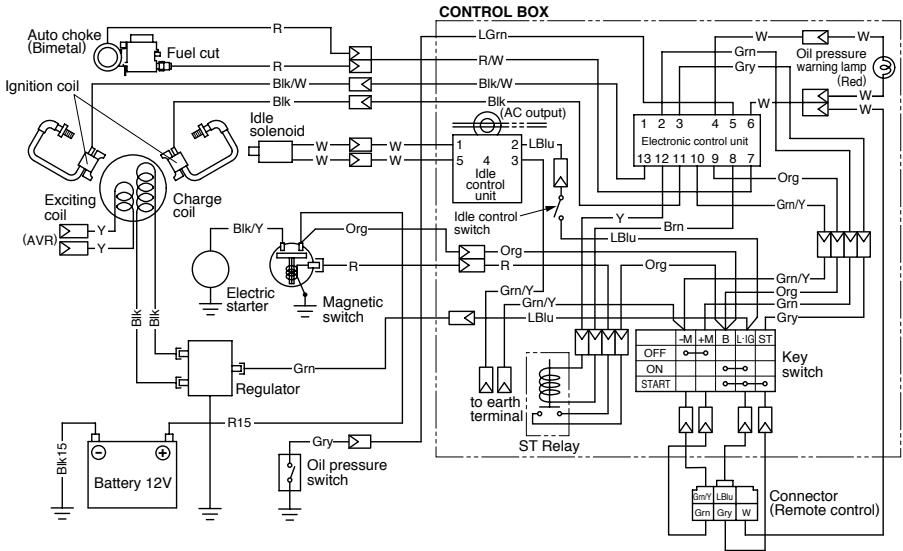

Wiring color cord

Blk : Black	Brn/W : Brown/White	R : Red	Blk/R : Black/Red
Blk/W : Black/White	Grn : Green	W : White	R/W : Red/White
Blu : Blue	Grn/W : Green/White	Y : Yellow	LGrn : Light green
LBlu : Light blue	Org : Orange	Pik : Pink	
Brn : Brown	Gry : Gray	Grn/Y : Green/Yellow	

Makita Corporation

3-11-8, Sumiyoshi-cho

Anjo, Aichi 446-8502 Japan

PRINTED IN JAPAN
October 2004 CE-SK

Download from Www.Somanuals.com. All Manuals Search And Download.

Free Manuals Download Website

<http://myh66.com>

<http://usermanuals.us>

<http://www.somanuals.com>

<http://www.4manuals.cc>

<http://www.manual-lib.com>

<http://www.404manual.com>

<http://www.luxmanual.com>

<http://aubethermostatmanual.com>

Golf course search by state

<http://golfingnear.com>

Email search by domain

<http://emailbydomain.com>

Auto manuals search

<http://auto.somanuals.com>

TV manuals search

<http://tv.somanuals.com>