

Makita GENERATOR

アメリカ

G series

MODEL **G2800R**
G4100R
G4101R
G6100R
G6101R

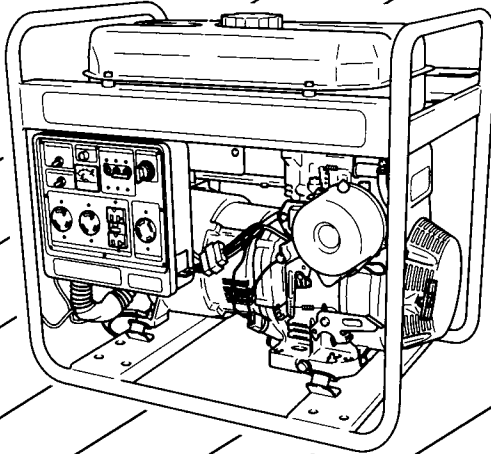

INSTRUCTIONS FOR USE

3ZZ9020076



WARNING:



The engine exhaust from this product contains chemicals known to the State of California to cause cancer, birth defects or other reproductive harm.

FEDERAL EMISSION COMPONENT DEFECT WARRANTY

EMISSION COMPONENT DEFECT WARRANTY COVERAGE – This emission warranty is applicable in all States, except the State of California

MAKITA U. S. A. Inc., La Mirada, California, (herein "MAKITA") warrants to the initial retail purchaser and each subsequent owner, that this utility equipment engine (herein "engine") was designed, built, and equipped to conform at the time of initial sale to all applicable regulations of the U. S. Environmental Protection Agency (EPA), and that the engine is free of defects in materials and workmanship which would cause this engine to fail to conform with EPA regulations during its warranty period.

For the components listed under PARTS COVERED, Makita Factory Service Center or Service Center authorized by MAKITA will, at no cost to you, make the necessary diagnosis, repair, or replacement necessary to ensure that the engine complies with applicable U. S. EPA regulations.

EMISSION COMPONENT DEFECT WARRANTY PERIOD

The warranty period for this engine begins on the date of sale to the initial purchaser and continues for a period of 2 years.

PARTS COVERED

Listed below are the parts covered by the Emission Component Defect Warranty.

Some of the parts listed below may require scheduled maintenance and are warranted up to the first scheduled replacement point for that part.

- 1) Fuel Metering System
 - (a) Carburetor and its internal parts
- 2) Ignition System
 - (a) Spark plug
 - (b) Flywheel Magneto
 - (c) Ignition Coil
- 3) Other Miscellaneous Items Used in Above Systems
 - (a) Fuel Hoses
 - (b) Sealing Gaskets

OBTAINING WARRANTY SERVICE

To obtain warranty service, take your engine to the nearest Makita Factory Service Center or Service Center authorized by MAKITA. Bring your sales receipts indicating date of purchase for this engine. Makita Factory Service Center or Service Center will perform the necessary repairs or adjustments within a reasonable amount of time and furnish you with a copy of the repair order.

All parts and accessories replaced under this warranty become the property of MAKITA.

WHAT IS NOT COVERED

- * Conditions resulting from tampering, misuse, improper adjustment (unless they were made by Makita Factory Service Center or Service Center authorized by MAKITA during a warranty repair), alteration, accident, failure to use the recommended fuel and oil, or not performing required maintenance services.
- * The replacement parts used for required maintenance services.
- * Consequential damages such as loss of time, inconvenience, loss of use of the engine of

equipment, etc.

- * Diagnosis and inspection charges that do not result in warranty-eligible service being performed.
- * Any non-authorized replacement part, or malfunction of authorized parts due to use of non-authorized parts.

OWNER'S WARRANTY RESPONSIBILITIES

As the engine owner, you are responsible for the performance of the required maintenance listed in your owner's manual. MAKITA recommends that you retain all receipts covering maintenance on your engine, but MAKITA can not deny warranty solely for the lack of receipts or for your failure to ensure the performance of all scheduled maintenance.

As the engine owner, you should however be aware that the MAKITA may deny your warranty coverage if your engine or a part has failed due to abuse, neglect, improper maintenance or unapproved modifications.

You are responsible for presenting your engine to the nearest Makita Factory Service Center or Service Center authorized by MAKITA when a problem exists.

If you have any questions regarding your warranty rights and responsibilities, you should contact the MAKITA Warranty department at 1-800-4-MAKITA for the information.

THINGS YOU SHOULD KNOW ABOUT THE EMISSION CONTROL SYSTEM WARRANTY MAINTENANCE AND REPAIRS

You are responsible for the proper use and maintenance of the engine. You should keep all receipts and maintenance records covering the performance of regular maintenance in the event questions arise. These receipts and maintenance records should be transferred to each subsequent owner of the engine. MAKITA reserves the rights to deny warranty coverage if the engine has not been properly maintained. Warranty claims will not be denied, however, solely because of the lack of required maintenance or failure to keep maintenance records.

MAINTENANCE, REPLACEMENT OR REPAIR OF EMISSION CONTROL DEVICES AND SYSTEMS MAY BE PERFORMED BY ANY REPAIR ESTABLISHMENT OR INDIVIDUAL ; HOWEVER, WARRANTY REPAIRS MUST BE PERFORMED BY MAKITA FACTORY SERVICE CENTER OR SERVICE CENTER AUTHORIZED BY MAKITA. THE USE OF PARTS THAT ARE NOT EQUIVALENT IN PERFORMANCE AND DURABILITY TO AUTHORIZED PARTS MAY IMPAIR THE EFFECTIVENESS OF THE EMISSION CONTROL SYSTEM AND MAY HAVE A BEARING ON THE OUTCOME OF A WARRANTY CLAIM.

If other than the parts authorized by MAKITA are used for maintenance replacements or for the repair of components affecting emission control, you should assure yourself that such parts are warranted by their manufacturer to be equivalent to the parts authorized by MAKITA in their performance and durability.

HOW TO MAKE CLAIM

All repairs qualifying under this limited warranty must be performed by Makita factory Service Center or Service Center authorized by MAKITA. In the event that any emission-related part is found to be defective during the warranty period, you shall notify MAKITA Warranty department at 1-800-4-MAKITA and you will be given the appropriate warranty service facilities where the warranty repair can be performed.

California Emission Control Warranty Statement

[This warranty does not apply in any other state.]

YOUR WARRANTY RIGHTS AND OBLIGATIONS

The California Air Resources Board and Makita U.S.A., Inc. are pleased to explain the emission control warranty on your 1995 utility and /or lawn and garden equipment engine. In California, new utility and lawn and garden equipment engines must be designed, built and equipped to meet the State's stringent anti-smog standards. Makita U.S.A., Inc. must warrant the emission control system on your utility and/or lawn and garden equipment engine for the periods of time listed below provided there has been no abuse, neglect or improper maintenance of your utility and/or lawn and garden equipment engine.

Your emission control system includes parts such as the carburetor or fuel injection systems, the ignition system and the catalytic converter. Also included are the hoses, and connectors and other emission-related assemblies.

Where a warrantable condition exists, Makita U.S.A., Inc. will repair your utility and/or lawn and garden equipment at no cost to you including diagnosis, parts and labor.

MANUFACTURER'S WARRANTY COVERAGE :

The 1995 and later utility and/or lawn and garden equipment engines are warranted for two years. If any emission-related part on your engine is defective, the part will be repaired or replaced by Makita U.S.A., inc.

OWNER'S WARRANTY RESPONSIBILITIES :

As the utility and lawn and garden equipment engine owner, you are responsible for the performance of the required maintenance listed in your owner's manual. Makita U.S.A., Inc. recommends that you retain all receipts covering maintenance on your utility and /or lawn and garden equipment engine, but Makita U.S.A., Inc. cannot deny warranty solely for the lack of receipts or for your failure to ensure the performance of all scheduled maintenance.

As the utility and/or lawn and garden equipment engine owner, you should be aware, however, that Makita U.S.A., Inc. may deny you warranty coverage if your utility and/or lawn and garden equipment engine or a part has failed due to abuse, neglect, improper maintenance or unapproved modifications.

You are responsible for presenting your utility and/or lawn and garden equipment engine to a Makita U.S.A., inc. service center as a problem exists. The warranty repairs should be completed in a reasonable time, not to exceed 30 days.

If you have any questions regarding your warranty rights and responsibilities, you should contact a Makita Factory Service Center Manager nearest you. A list of the Factory Service Center locations and phone numbers is provided below for your convenience.

LIMITED WARRANTY

—California Only—

Makita U.S.A., Inc., a distributor of utility and lawn and garden equipment in the U.S., warrants to the owner of 1995 and later utility and/or lawn and garden equipment engines that the engine(1) has been designed, built, and equipped at the time of manufacture so as to conform with the applicable regulations of the California Air Resources Board and, (2) is free from defects in materials and workmanship which may cause it to fail to conform with those regulations as applicable according to the terms and conditions stated below.

WARRANTY PERIOD

The warranty period begins on the date which the utility and/or lawn and garden equipment engine is delivered to the original retail purchaser and ends two years after that date. During this two year period Makita U.S.A., inc. warrants to the original retail purchaser and each subsequent purchaser that the engine is free from defect in material and workmanship that can cause the failure of a warranted emission-related part.

WHAT IS COVERED UNDER THIS WARRANTY

Repair and/or replacement of any warranted emission-related part will be performed at no charge provided the work is performed at an authorized warranty station. There will also be no charge for any diagnostic labor performed at an authorized warranty station which leads to the determination that a warranted emission-related part is defective.

Any warranted part which is not scheduled for replacement as required maintenance, or which is scheduled only for regular inspection to the effect of“repair or replace as necessary”shall be warranted for the warranty period. Any warranted part which is scheduled for replacement as required maintenance shall be warranted for the period of time up to the first scheduled replacement of that part. This warranty shall apply only towards the repair, replacement, and/or adjustment of the component parts listed below.

EMISSION-RELATED PARTS COVERED UNDER THIS WARRANTY

1. Fuel Metering Systems
 - (a) Carburetor and its internal parts
2. Ignition Systems
 - (a) Spark plug
 - (b) Flywheel Magneto
 - (c) Ignition Coil
3. Other Miscellaneous Items Used in Above Systems
 - (a) Fuel Hoses
 - (b) Sealing Gaskets

If it is determined by an authorized warranty station that other engine components have been damaged due to the failure of a warranted emission-related part during the warranty period, Makita U.S.A., Inc. will repair and/or replace the necessary components.

WHAT IS NOT COVERED UNDER THIS WARRANTY

This warranty does not cover any emission-related part which malfunctions, fails, or is damaged due to alterations and/or modifications such as changing, adding, or removing parts.

When an engine is being serviced under warranty, Makita U.S.A., Inc. and any of its authorized dealers, distributors, or warranty stations shall not be liable for any loss of use of the engine, for any damage to goods, or loss of time or inconvenience.

This limited warranty also does not apply to any emission-related part which malfunctions, fails, or is damaged due to failure to follow the maintenance and operating instructions specified in the 1995 and later Owner's Manual including.

- (a) Improper or inadequate maintenance of any warranted emission-related part.
- (b) Improper installation, adjustment, or repair of the engine or any warranted emission-related part unless performed by a factory authorized warranty station.
- (c) Failure to use recommended fuel as specified in the 1995 and later Owner's Manual.
- (d) Repairs and diagnosis performed outside of an authorized warranty station.
- (e) Use of parts which are not authorized by Makita U.S.A., Inc.

MAINTENANCE SCHEDULE

The engine owner is responsible for having all scheduled inspection and maintenance services performed at the intervals specified in the 1995 and later Owner's Manual and to retain records of these services as having been performed. These records should be transferred to each subsequent owner of the engine. Makita U.S.A., Inc. cannot deny a claim solely because there are no records of scheduled maintenance, however, a warranty claim may be denied if the failure to perform the scheduled maintenance and inspection resulted in the failure of a warranted emission-related part. As a minimum, the engine owner is responsible for the scheduled inspection and maintenance described below which are based on the procedures described in the Owner's Manual.

PROCEDURE

INTERVAL

- | | |
|--|-------------------------------------|
| (a) Check all nuts and bolts and tighten as necessary. | Every 8 hours of use or daily. |
| (b) Check air passages and engine cylinder fins for clogging.
Remove all obstructions as necessary. | Every 8 hours of use or daily. |
| (c) Check air cleaner. | Every 8 hours of use or daily. |
| (d) Check spark plug.
Clean and adjust if necessary. | Every 8 hours of use or daily. |
| (e) Check muffler exhaust port.
Clean if necessary. | Every 50 hours of use or monthly. |
| (f) Replace fuel lines. | Every 200 hours of use or annually. |
| (g) Overhaul engine. | Every 200 hours of use or annually. |
| (h) Replace packings and gaskets. | Every time engine is reassembled. |

REPAIR AND REPLACEMENT OF EMISSION-RELATED PARTS

It is recommended that only engine replacement parts which have been authorized and approved by Makita U.S.A., Inc. should be used in the performance of any warranty maintenance or repairs of emission-related parts. These replacement parts will be provided at no charge if the part is still under warranty.

HOW TO FILE A WARRANTY CLAIM AND WHERE TO GET WARRANTY SERVICES

Contact the nearest Makita Factory Service Center Manager to determine the appropriate location where the required warranty services are to be performed. A list of the Factory Service Center locations and phone numbers are provided below for your convenience.

14930-B Northam Street
La Mirada, CA 90638
(714) 522-8088

41850 Christy Street
Fremont, CA 94538
(510) 657-9881

1401 N.Clovis Ave., Ste. 110
Fresno, CA 93727
(209) 252-5166

4554 Roseville Rd., Ste. E
North Highlands, CA 95660
(916) 331-6211

392 S. Arrowhead, #A-1
San Bernardino, CA 92408
(714) 885-1289

7674 Clairemont Mesa Blvd.
San Diego, CA 92111
(615) 278-4471

180 S Spruce Ave., Unit D
South San Francisco, CA 94080
(415) 875-1002

15722-B Tustin Village Way
Tustin, CA 92680
(714) 667-5066

16735 Saticoy St., Ste. 105
Van Nuys, CA 91406
(818) 782-2440

FOREWORD

Thank you for purchasing a Makita generator.

This manual covers operation and maintenance of the Makita generators. All information in this publication is based on the latest production information available at the time of approval for printing.

Pay special attention to statements preceded by the following words:

WARNING

Indicates a strong possibility of severe personal injury, loss of life and equipment damage if instructions are not followed.

[CAUTION]

Indicates a possibility of personal injury or equipment damage if instructions are not followed.

NOTE:

Gives helpful information.

If a problem should arise, or if you have any questions about the generator, consult an authorized dealer or service shop





WARNING









- **The generator is designed to give safe and dependable service if operated according to instructions.**
- **Do not operate the generator before you have read and understood the instructions. Failure to do so could result in death, personal injury or equipment damage.**

CONTENTS

1. SAFETY PRECAUTIONS	·1
2. SPECIFICATIONS	·4
3. COMPONENTS	·5
4. PRE-OPERATION CHECKS	·6
5. OPERATING PROCEDURES	·9
6. WATTAGE INFORMATION	·22
7. MAINTENANCE SCHEDULE	·24
8. "HOW-TO" MAINTENANCE	·26
9. PREPARATION FOR STORAGE	·28
10. TROUBLESHOOTING	·29
11. WIRING DIAGRAM	·30
12. OPTIONAL PARTS	·35

1. SAFETY PRECAUTIONS

-  Do not operate the generator near gasoline or gaseous fuel because of the potential danger of explosion or fire.
Do not fill the fuel tank with fuel while the engine is running. Do not smoke or use open flame near the fuel tank. Be careful not to spill fuel during refueling. If fuel is spilled, wipe it off and let dry before starting the engine.
-  Do not place in flammables near the generator.
Be careful not to place fuel, matches, gunpowder, oily cloths, straw, trash, or any other in flammables near the generator.
-  Do not operate the generator inside a room, cave, tunnel, or other insufficiently ventilated area. Always operate it in a well-ventilated area, otherwise the engine may become overheated, and the poisonous carbon monoxide gas contained in the exhaust gases will endanger human lives. Keep the generator at least 1 meter (3 feet) away from any structure or building during use. If the generator must be used indoors, the area must be well-ventilated and extreme caution must be taken regarding the discharge of exhaust gases.
-  Do not enclose the generator nor cover it with a box.
The generator has a built-in forced air cooling system, and may become overheated if it is enclosed. If generator has been covered to protect it from the weather during non use, be sure to remove it and keep it well away from the area during generator use.
-  Operate the generator on a level surface.
It is not necessary to prepare a special foundation for the generator. However, the generator will vibrate on an irregular surface, so choose a level place without surface irregularities.
If the generator is tilted or moved during operation, fuel may spill and / or the generator may tip over, causing a hazardous situation.
Proper lubrication cannot be expected if the generator is operated on a steep incline or slope. In such a case, piston seizure may occur even if the oil is above the upper level.

-
-  Pay attention to the wiring or extension cords from the generator to the connected device.
If the wire is under the generator or in contact with a vibrating part, it may break and possibly cause a fire, generator burnout, or electric shock hazard. Replace damaged or worn cords immediately.
 -  Do not operate in rain, in wet or damp conditions, or with wet hands.
The operator may suffer severe electric shock if the generator is wet due to rain or snow.
 -  If wet, wipe and dry it well before starting. Do not pour water directly over the generator, nor wash it with water.
 -  Be extremely careful that all necessary electrical grounding procedures are followed during each and every use. Failure to do so can be fatal.
 -  Do not contact the generator to a commercial power line. Connection to a commercial power line may short circuit the generator and ruin it or cause electric shock hazard. Use the transfer switch for connecting to domestic circuit.
 -  No smoking while handling the battery. The battery emits flammable hydrogen gas, which can explode if exposed to electric arcing or open flame.
Keep the area well-ventilated and keep open flames/sparks away when handling the battery.
 -  Engine becomes extremely hot during and for some time after operation.
Keep combustible materials well away from generator area.
Be very careful not to touch any parts of the hot engine especially the muffler area or serious burns may result.
 -  Keep children and all bystanders at a safe distance from work areas.

 It is absolutely essential that you know the safe and proper use of the power tool or appliance that you intend to use. All operators must read, understand and follow the tool/appliance owners manual. Tool and appliance applications and limitations must be understood. Follow all directions given on labels and warnings. Keep all instruction manuals and literature in a safe place for future reference.

 Use only "LISTED" extension cords.
When a tool or appliance is used outdoors, use only extension cords marked "For Outdoor Use". Extension cords, when not in use should be stored in a dry and well ventilated area.

 Always switch off generator's no-fuse breaker and disconnect tools or appliances when not in use, before servicing, adjusting, or installing accessories and attachments.

2. SPECIFICATIONS

MODEL		G2800R	G4100R, G4101R	G6100R, G6101R	
Alternator	Type	Brushless, Self-Exciting, 2-Poles, Single Phase			
	Voltage regulator	Condenser type			
	Rated voltage	60 Hz	120 V	120 V/ 240 V	
	Maximum output	60 Hz	2.8 kW	4.1 kW	5.8 kW
	Rated output	60 Hz	2.3 kW	3.6 kW	4.8 kW
	Rated power factor	1.0			
	DC output	12V-8.3A			
	Over current protector	No-fuse Breaker			
Engine	Model	Robin EH17-2D	Robin EH25-2D	Robin EH34D	
	Type	Forced air-cooled, 4-cycle, Gasoline Engine			
	Displacement	172 cm ³	251 cm ³	338 cm ³	
	Fuel	Automobile Gasoline			
	Fuel tank capacity	3.17 US-gal (12.0 liter)	4.39 US-gal (16.6 liter)	5.68 US-gal (21.5 liter)	
	Rated continuous operation (Approx.)	60 Hz	9.0 hours	7.0 hours	7.0 hours
	Starting system	Recoil	Recoil (Electric starter)*		
Dimension	Length	22.4 in. (570 mm)	24.4 in. (620 mm)	26.8 in. (680 mm)	
	Width	16.1 in. (410 mm)	17.7 in. (450 mm)	18.5 in. (470 mm)	
	High	19.3 in. (490 mm)	21.3 in. (540 mm)	24.4 in. (619 mm)	
Dry weight (Electric start type)		21.8 lb (48 kg)	27.2 lb (60 kg) 28.8 lb (63.5 kg)*	35.3 lb (78 kg) 37.0 lb (81.5 kg)*	

Specifications are subject to change without notice.

* : Electric starter is available as option

3. COMPONENTS

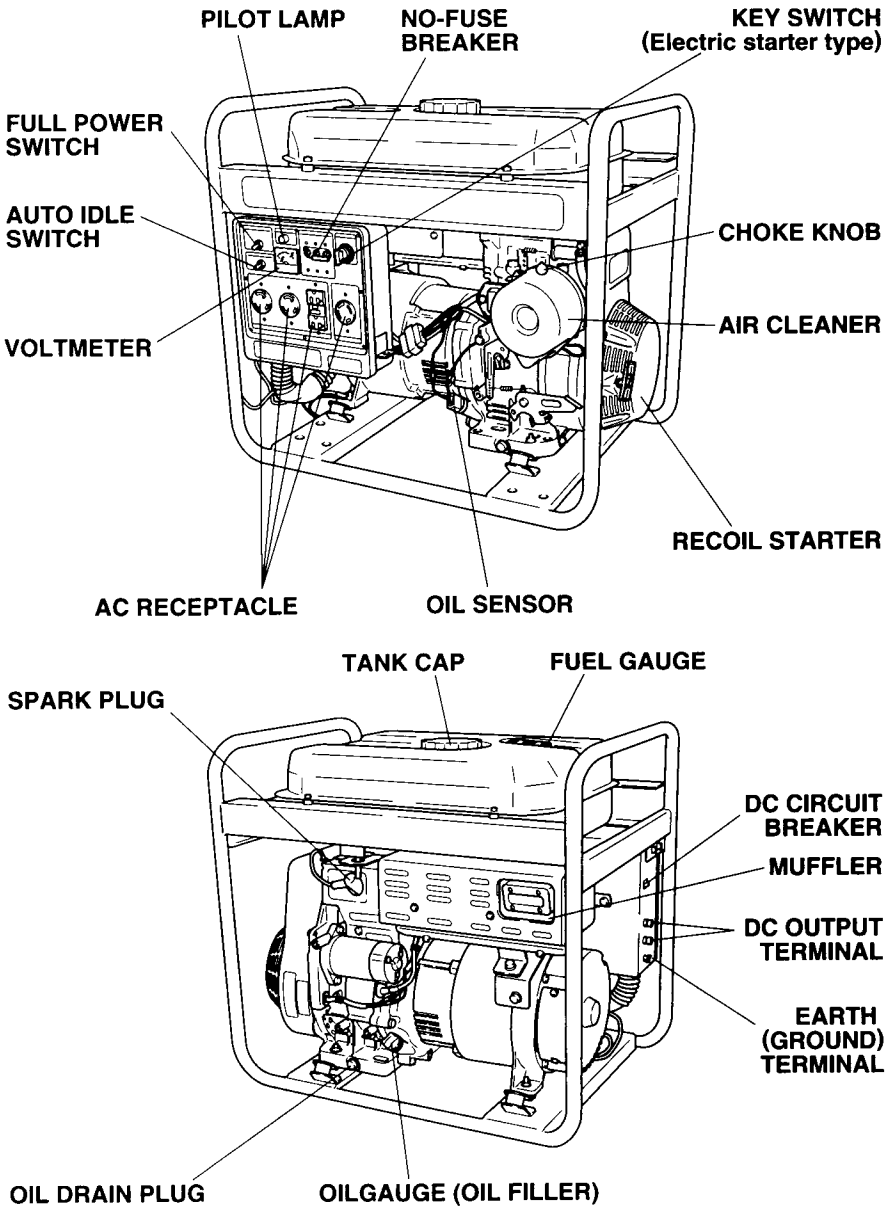

4. PRE-OPERATION CHECKS

CHECK ENGINE OIL.

Before checking or refilling oil, be sure generator is located on stable and level surface with engine stopped.

- Remove oil filler cap and check the engine oil level.
- If oil level is below the lower level line, refill with suitable oil (see table) to upper level line. Do not screw in the oil filler cap when checking oil level.
- Change oil if contaminated.
(See "How-To" Maintenance.)

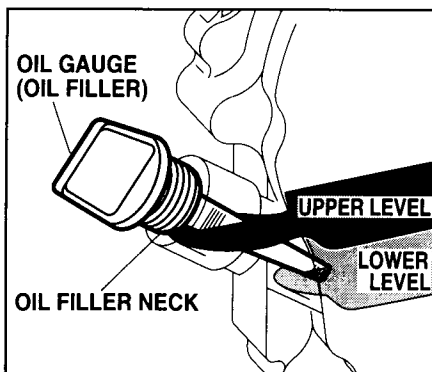

Oil capacity

Model	Upper level
G2800R	0.17 US-gal. (0.65 liter)
G4100R,G4101R	0.26 US-gal. (1.0 liter)
G6100R,G6101R	0.32 US-gal. (1.2 liter)

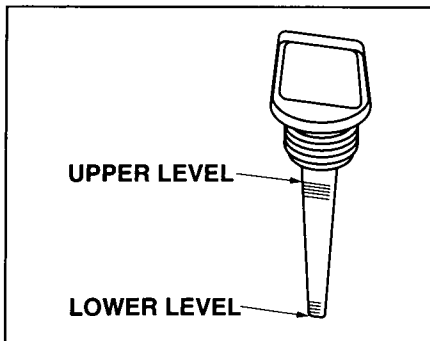

Recommended engine oil :

Use class SE (API classification) oil or a higher grade oil according to the table below. SAE 10W-30 or 10W-40 is recommended for general, all-temperature use. If single viscosity oil is used, select the appropriate viscosity for the average temperature in your area.

Single grade	5W						
	10W						
	20W						
	#20						
	#30						
Multigrade	10W-30						
	10W-40						
Ambient temperature	-20	-10	0	10	20	30	40°C
	-4	14	32	50	68	86	104°F

CHECK ENGINE FUEL.

⚠ WARNING

Do not refuel while smoking or near open flame or other such potential fire hazards. Otherwise fire accident may occur.

- Check fuel level at fuel level gauge.
- If fuel level is low, refill with unleaded automotive gasoline.
- Be sure to use the fuel filter screen on the fuel filter neck.

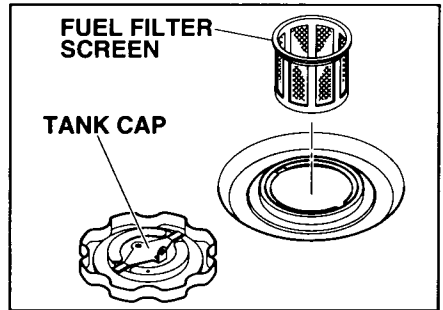

Fuel tank capacity :

G2800R · · · · · 3.17 US-gal. (12.0 liter)

G4100R,G4101R · · 4.39 US-gal. (16.6 liter)

G6100R,G6101R · · 5.68 US-gal. (21.5 liter)

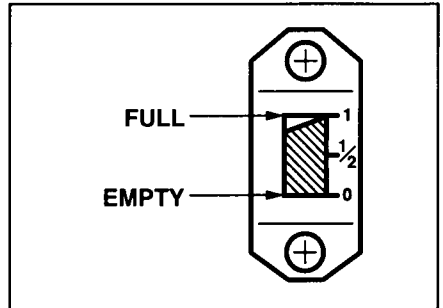

⚠ WARNING

Make sure you review each warning in order to prevent fire hazard.

- Do not refill tank while engine is running or hot.
- Close fuel cock before refueling with fuel.
- Be careful not to admit dust, dirt, water or other foreign objects into fuel.
- Wipe off spilt fuel thoroughly before starting engine.
- Keep open flames away.

CHECKING COMPONENT PARTS

Check following items before starting engine:

- Fuel leakage from fuel hose, etc.
- Bolts and nuts for looseness.
- Components for damage or breakage.
- Generator not resting on or against any adjacent wiring.

CHECK GENERATOR SURROUNDINGS.

⚠ WARNING

Make sure you review each warning in order to prevent fire hazard.

- **Keep area clear of in flammables or other hazardous materials.**
- **Keep generator at least 3 feet (1 meter) away from buildings or other structures.**
- **Only operate generator in a dry, well ventilated area.**
- **Keep exhaust pipe clear of foreign objects.**
- **Keep generator away from open flame. No smoking!**
- **Keep generator on a stable and level surface.**
- **Do not block generator air vents with paper or other material.**

GROUNDING THE GENERATOR

- To ground the generator to the earth, connect the grounding lug of the generator to the grounding spike driven into the earth or to the conductor which has been already grounded to the earth.
- If such grounding conductor or grounding electrode is unavailable, connect the grounding lug of the generator to the grounding terminal of the using electric tool or appliance.

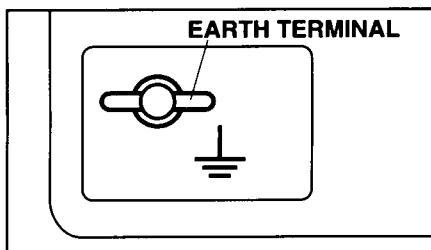
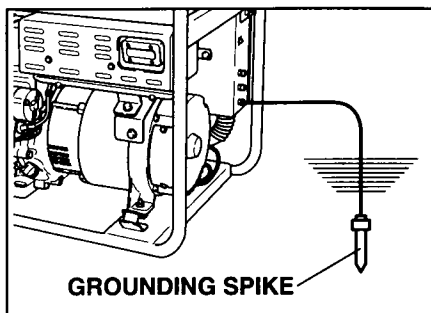

5. OPERATING PROCEDURES

STARTING THE ENGINE

[CAUTION]

Check the oil level before each operations as outlined on page 6.

(a) Turn the engine switch to the position "ON". (Recoil starter model only)

(b) Turn the no-fuse breaker to the "OFF" position.

(c) Open the fuel cock.

(d) Pull the choke knob to close if the engine is cold.

(e) [Recoil starter model]

Pull the starter handle slowly until resistance is felt.

This is the "compression" point.

Return the handle to its original position and then pull swiftly.

- If the engine fails to start after several attempts, repeat above procedures with choke knob returned to open.
- Do not fully pull out the rope.
- After starting, allow the starter handle to return to its original position while still holding the handle.

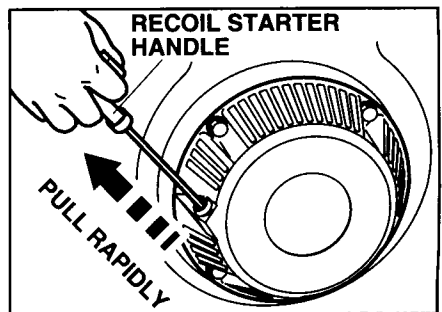
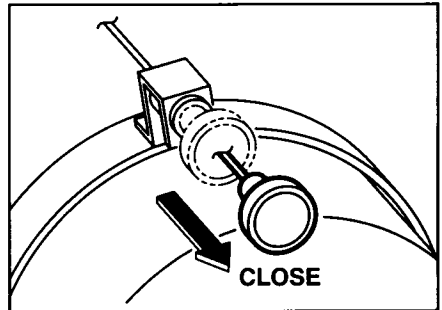
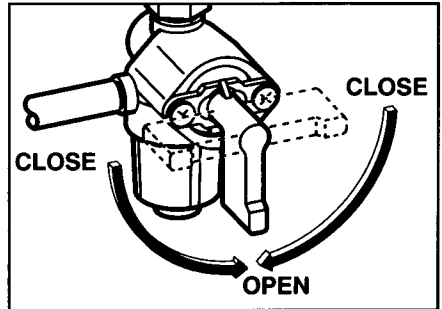
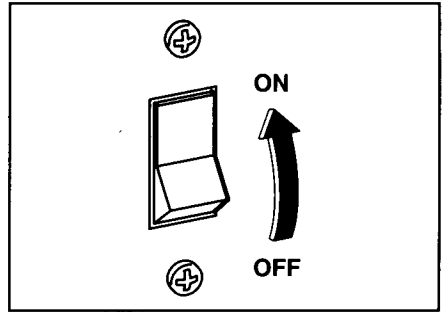

(f) **[Electric starter model]**

Insert the key into the key switch and turn it clockwise to the "RUN" position to start the engine.

Then turn the key further to the "START" position. The engine will be started by starting motor.

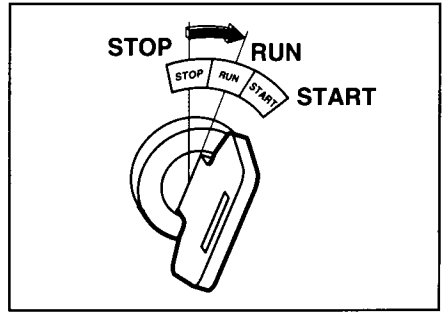

[CAUTION]

- Do not run the starting motor over 5 seconds continuously. If the engine fails to start, return the key to the "RUN" position and wait about 10 seconds then start again.
- Do not turn the key switch to "START" when the engine is running to prevent damage of starting motor.
- Do not turn the key switch to "START" position when the engine is running to prevent damage of starting motor.
- When starting the engine by recoil starter, set the key switch at the "ON" position and pull the starter handle.

(g) After the engine started, return the choke knob gradually to "OPEN" position.

(h) Warm up the engine without a load for a few minutes.

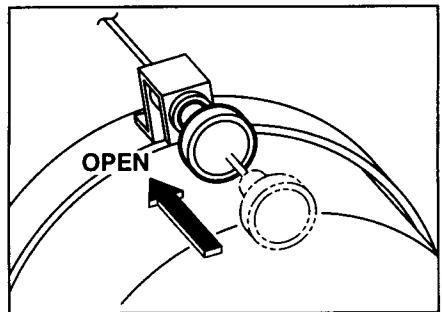

USING ELECTRIC POWER

⚠ WARNING

- Make sure that the appliance is switched OFF before connecting it to the generator.
- Do not move the generator while it is running.
- Be sure to ground the generator if the connected appliance is grounded. Failure to ground unit may lead to electrical shock.

CONTROL PANEL (G2800R)

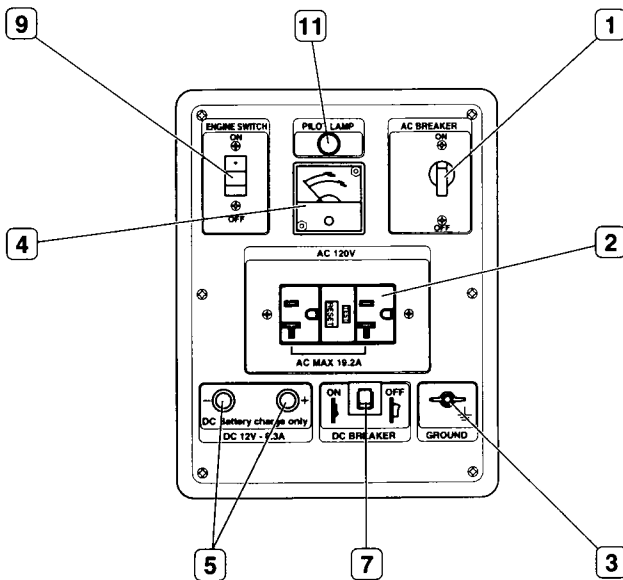

- | | |
|---------------------------|----------------------|
| 1 No-fuse breaker | 7 DC circuit breaker |
| 2 AC receptacle | 8 Auto idle switch |
| 3 Earth (Ground) terminal | 9 Engine switch |
| 4 Voltmeter | 10 Key switch |
| 5 DC output terminal | 11 Pilot lamp |
| 6 Full power switch | |

(G4101R / G4100R)

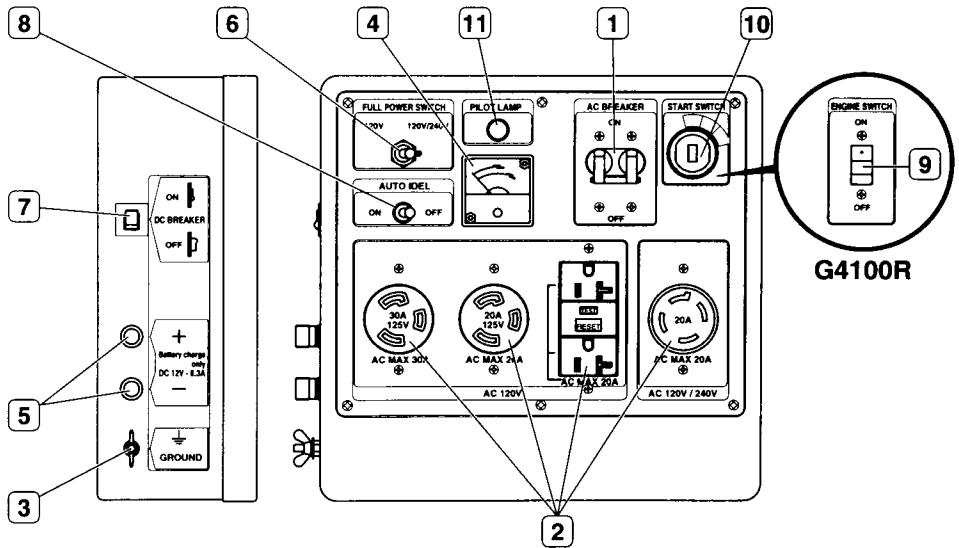

(G6101R / G6100R)

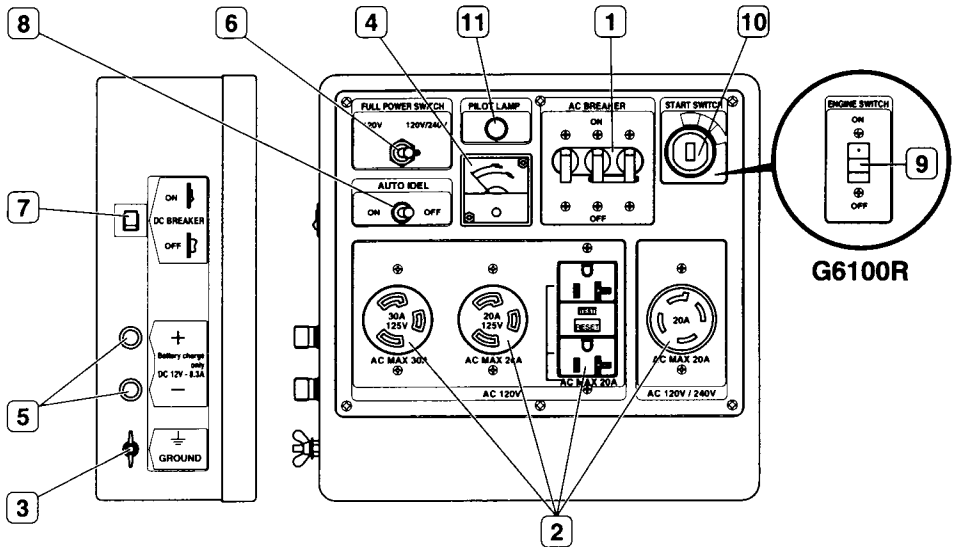

(1) AC APPLICATION

(a) Check the pilot lamp for proper voltage.

- This generator is thoroughly tested and adjusted in the factory. If the generator does not produce the specified voltage, consult your nearest Makita factory or authorized service center.

(b) Turn off the switch (es) of the electrical appliance (s) before connecting to the generator.

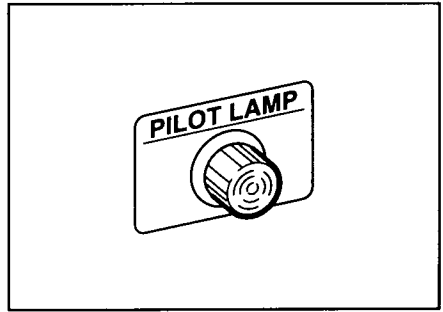

(c) Insert the plug (s) of the electrical appliance(s) into the receptacle.

- Check the amperage of the receptacles used referring to **TABLE 1**, and be sure not to take a current exceeding the specified amperage.
- Be sure that the total wattage of all appliances dose not exceed the rated output of the generator.

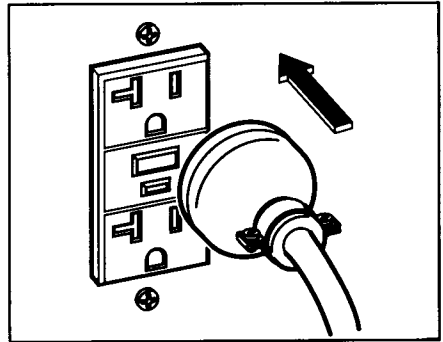

(d) Turn the no-fuse breaker to the position "ON".

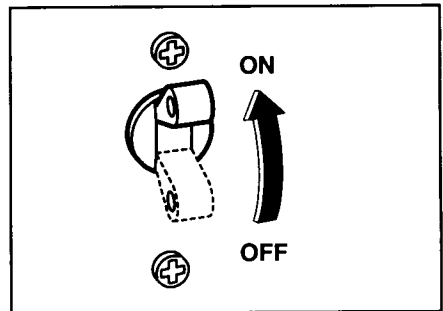





Style	Ampere	Receptacle	AC plug	Description
	up to 20A	NEMA 5-20R	NEMA 5-20P	GFCI (Ground Fault Circuit Interrupter) Receptacle, duplex (REC 1)
	up to 20A	NEMA L14-20R	NEMA L14-20P	Locking Receptacle (REC 4)
	up to 30A	NEMA L5-30R	NEMA L5-30P	Locking Receptacle (REC 2)
	up to 20A	NEMA L5-20R	NEMA L5-20P	Locking Receptacle (REC 3)

TABLE 1

⚠ WARNING

- To take power out from the TWIST LOCK RECEPTACLE, insert the plug into the receptacle, and turn it clockwise to the lock position.
- Be sure to ground the generator if the connected electrical device is grounded.

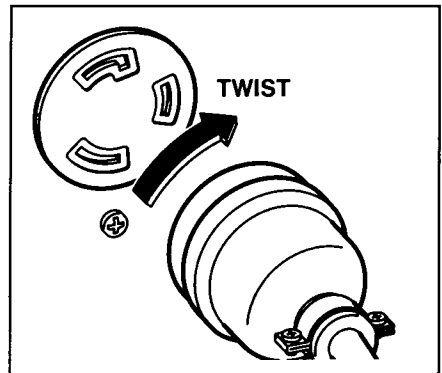

NOTE :

When the no-fuse breaker turns off during operation, the generator is over loaded or the appliance is defective. Stop the generator immediately, check the appliance and / or generator for overloading or detect and have repaired as necessary by Makita factory or authorized service center.

[CAUTION]

The duplex 120V receptacle is protected by a GFCI (Ground Fault Circuit Interrupter). GFCI shuts off the output current from the duplex 120V receptacle when a ground fault occurs in the generator or the appliance. Please note that other receptacles are not protected by GFCI.

GFCI RECEPTACLE

After starting the engine, check the GFCI for proper functioning by the following test procedure.

- Push yellow TEST button, The red RESET button will pop out exposing the word TRIP. Power is now off at the outlets protected by the GFCI, indicating that the device is functioning properly.
- If TRIP dose not appear when testing, do not use the generator. Call a qualified electrician.
- To restore power, push RESET button.

⚠ WARNING

If the RESET button pops out during operation, stop the generator immediately and call a qualified electrician for checking generator and the appliances.

FULL POWER SWITCH

Select the voltage using the FULL POWER SWITCH in accordance with the electrical appliance.
Refer to **TABLE 2**.

[CAUTION]

Change the FULL POWER SWITCH after turning the no-fuse breaker to "OFF".

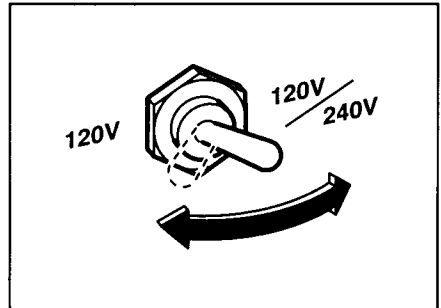

NOTE :

Voltmeter always indicates the lower voltage whichever the FULL POWER SWITCH is set.

Switch position	Lower Voltage Receptacle	Higher Voltage Receptacle
120V	Activated full rated output	N.A
120/240V	Activated half of rated output	Activated full rated output

TABLE 2

(2) CONNECTING TO DOMESTIC CIRCUITS (HOUSE WIRING)

⚠ WARNING

All Makita generators are a neutral ungrounded type.

If a generator is to be connected to residential or commercial power lines, such as a stand-by power source during power outage, all connections must be made by a licensed electrician.

Failure in connection may result in death, personal injury, damage to generator, damage to appliances, damage to the building's wiring or fire.

(a) When connecting a Makita generator to a house wiring, generator output power must be taken from the 240V-4P receptacle.

(b) Install a transfer switch.

A transfer switch must be installed to transfer the load from the commercial power source to the generator. This switch is necessary to prevent accidents caused by the recovery from power outage. Use a transfer switch of the correct capacity.

Install transfer switch between the meter and the fuse or AC breaker box.

[CAUTION]

If the neutral wire of house wiring is grounded, be sure to ground the ground terminal of the generator. Otherwise an electric shock may occur to the operator.

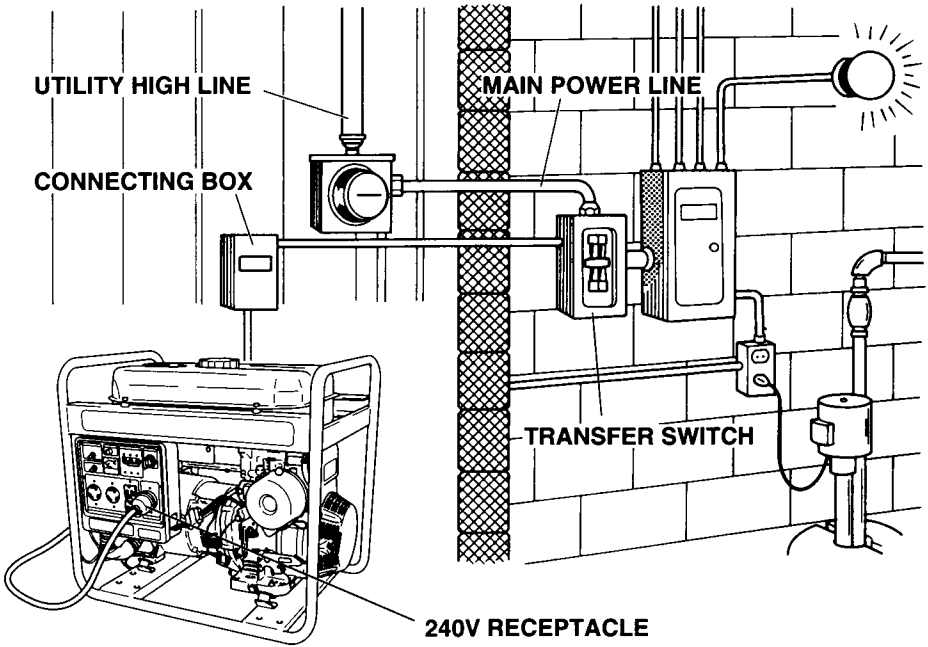

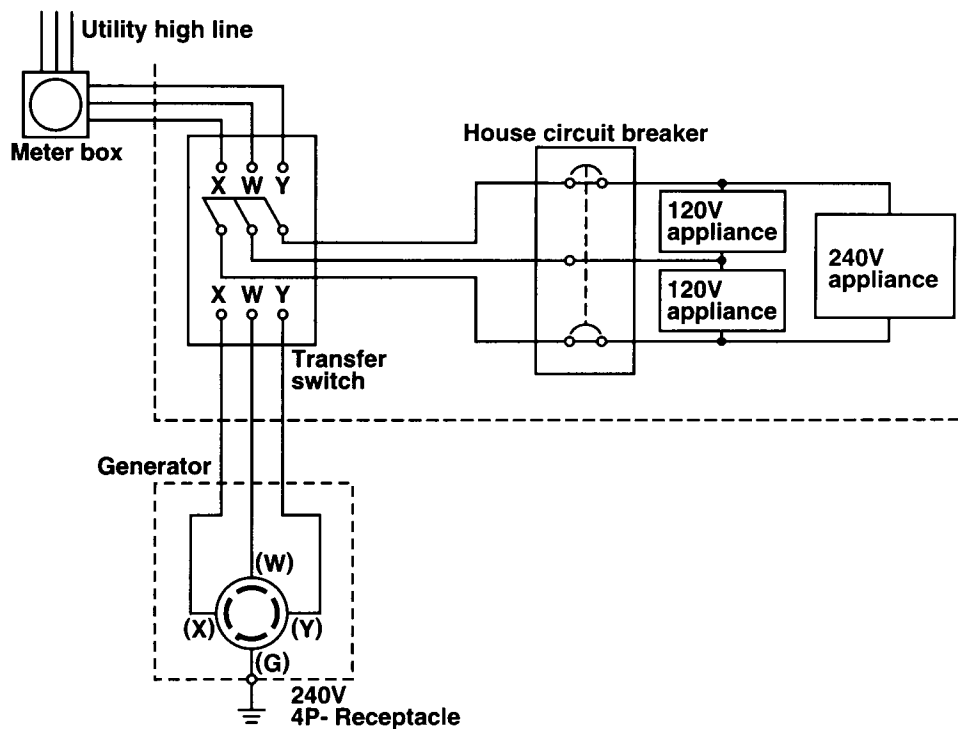

(c) Operating the generator.

- Set the full power switch to 120V/ 240V side.
- Turn the house AC breaker off before starting the generator.
- Start the generator and warm it up.
- Turn the house AC breaker on.

[CAUTION]

Do not start the generator with electrical appliance (s) connected and with their switches on.

Otherwise the appliance (s) may be damaged by the surge voltage at starting.

(3) DC APPLICATION

The DC terminal is used only for charging 12 volt batteries. It provides up to 12V-8.3A (100W) of maximum power.

CONNECTION OF CABLE :

- Connect positive (red) terminal on generator to positive (+) terminal on battery.
- Connect negative (black) terminal on generator to negative (-) terminal on battery.
- Both AC and DC output can be used at the same time if the total output is within rated output of the generator.

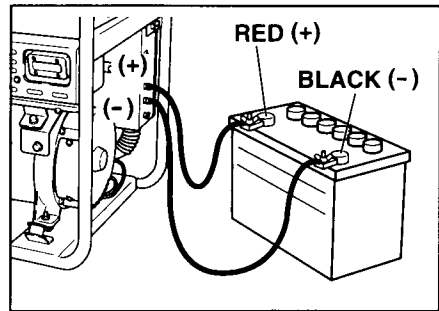

SAFETY PRECAUTIONS WHILE CHARGING

- An explosive hydrogen gas is discharged through vent holes in the battery during the charging process. Do not allow spark or open flame around the generator or battery during the charging process.
- Electrolyte fluid can burn eyes and clothing. Be extremely careful to avoid contact. If injured, wash the affected area immediately with large quantities of water and consult a doctor for treatment.
- When charging a large capacity battery or totally discharged battery, excessive current may force the DC breaker to turn off. In such cases, use a battery charger to charge a large battery with AC output.
- Battery defects may cause the DC breaker to turn off. Check the battery before replacing the DC breaker.

STOPPING THE GENERATOR

- (a) Turn off the power switch of the electric equipment and unplug the cord from receptacle of the generator.
- (b) Turn the no-fuse breaker to the "OFF" position.
- (c) Allow the engine about 3 minutes to cool down at no-load before stopping.
- (d) **[Recoil starter model]**
Turn the engine switch to the position "OFF".
[Electric starter model]
Turn the key switch to the STOP position.
- (e) Close the fuel cock.

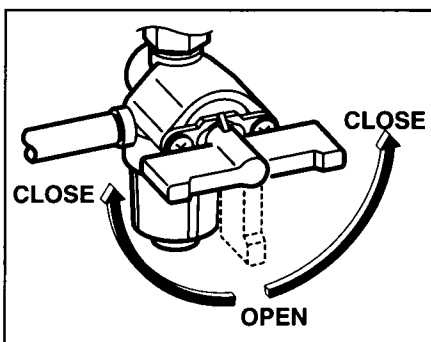
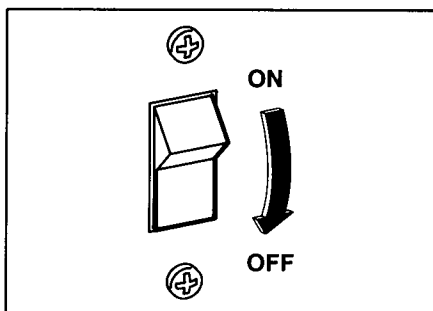

OIL SENSOR

- (a) The oil sensor detects the fall in oil level in the crankcase and automatically stops the engine when the oil level falls below a predetermined level.
- (b) When engine has stopped automatically, switch off generator's no-fuse breaker, and check the oil level. Refill engine oil to the upper level as instructed on page 6 and restart the engine.
- (c) If the engine does not start by usual starting procedures, check the oil level.

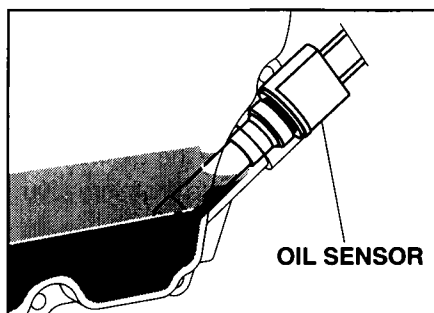

[CAUTION]

Do not remove OIL SENSOR PROBE when refilling with oil.
Remove oil filler cap on the opposite side of carburetor.

AUTO IDLE (Except G2800R)

AUTO IDLE automatically reduces engine speed when load is OFF, and automatically increases engine speed to rated r.p.m. when load is ON.

AUTO IDLE provides fuel economy and low noise operation at no-load running.

(1) HOW TO USE AUTO IDLE

- Start the engine with AUTO IDLE SWITCH off.

NOTE :

Warm up the engine without a load for a few minutes.

- Turn AUTO IDLE SWITCH on.

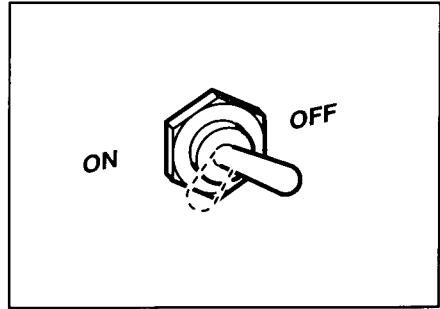

(2) CHECKING THE OPERATION

When AUTO IDLE does not operate normally, please check following :

- Overloaded ?
Please make it sure that the generator is not overload.

NOTE :

Most induction loads such as electric motors require three to five times more wattage than their ratings during starting.

This starting wattage should not exceed the rated output of the generator for proper operation of AUTO IDLE.

- Turn AUTO IDLE SWITCH off when the AUTO IDLE does not work normally under the rated output.

NOTE :

The AUTO IDLE may not operate when the applied load is under 40W. In such cases turn the AUTO IDLE SWITCH off.

(3) STOPPING THE ENGINE

- Turn off the switch of load.
- Switch off generator's AC breaker.
- Disconnect tool or appliance.
- Turn the AUTO IDLE SWITCH off.
- Turn the STOP SWITCH to the position "O" (OFF).

NOTE :

Allow the engine about 3 minutes to cool down at no-load before stopping.

6. WATTAGE INFORMATION

Some appliances need a "surge" of energy when starting.

This means that the amount of electrical power needed to start the appliance may exceed the amount needed to maintain its use.

Electrical appliances and tools normally come with a label indicating voltage, cycles / Hz, amperage (amps) and electrical power needed to run the appliance or tool.

Check with your nearest dealer or service center with questions regarding power surge of certain appliances or power tools.

- Electrical loads such as incandescent lamps and hot plates require the same wattage to start as is needed to maintain use.
- Loads such as fluorescent lamps require 1.2 to 2 times the indicated wattage during start-up.
- Loads for mercury lamps require 2 to 3 times the indicated wattage during start-up.
- Electrical motors require a large starting current. Power requirements depend on the type of motor and its use. Once enough "surge" is attained to start the motor, the appliance will require only 50% to 30% of the wattage to continue running.
- Most electrical tools require 1.2 to 3 times their wattage for running under load during use. For example, a 5,000 watt generator can power a 1800 to 4000 watt electrical tool.
- Loads such as submersible pumps and air compressors require a very large force to start. They need 3 to 5 times the normal running wattage in order to start. For example, a 5,000 watt generator would only be able to drive a 1,000 to 1,700 watt pump.

NOTE :

The following wattage chart is general guide only. Refer to your specific appliance for correct wattage.

To determine the total wattage required to run a particular electrical appliance or tool, multiply the voltage figure of the appliance/tool by the amperage (amps) figure of same. The voltage and amperage (amps) information can be found on a name plate which is normally attached to electrical appliances and tools.

Applications	Applicable Wattage (W)		
	G2800R	G4100R,G4101R	G6100R,G6101R
	60Hz	60Hz	60Hz
Incandescent lamp, Heater	2300	3600	4800
Fluorescent lamp, Electric tool	1200	1800	2400
Mercury lamp	800	1400	1600
Pump, Compressor	550	850	1100

VOLTAGE DROP IN ELECTRIC EXTENSION CORDS

When a long electric extension cord is used to connect an appliance or tool to the generator, a certain amount of voltage drop or loss occurs in the extension cord which reduces the effective voltage available for the appliance or tool.

The use of improper size or gauge of extension cords may cause unsafe or inefficient operation of your tool or appliance. It may also damage the tool or appliance. Be sure that any extension cord that you use is rated to allow sufficient current flow to the motor or appliance. Select the required wire gauge size according to the chart below. Chart lists the minimum wire gauge size for the proper extension cord.

EXTENSION CORD CHART

Use the right extension cord. An extension cord should have a suitable wire size for the overall cord length and tool amperage rating. This is to prevent a serious voltage drop, power loss and possible motor damage. Generally, heavier gauge wire is required as cord length increases. Use the recommendations in this table.

Extension Cord Length	Amperage Rating of Tool					
	0.2	2.1-3.4	3.5-5.0	5.1-7.0	7.1-12.0	12.1-16.0
	Recommended Wire Size (A.W.G. Gauge No.)					
7.5m	18	18	18	18	16	14
15m	18	18	18	16	14	12
22.5m	18	18	16	14	12	10
30m	18	16	14	12	10	8
45m	16	14	12	10	8	8
60m	16	14	12	10	8	6
90m	14	12	10	8	6	4
120m	12	10	8	6	4	4
150m	12	10	8	6	4	2
180m	10	8	6	4	2	2
240m	10	8	6	4	2	1

Not normally available as flexible extension cord.

7. MAINTENANCE SCHEDULE

DAILY INSPECTION

Before running the generator, check the following service items:

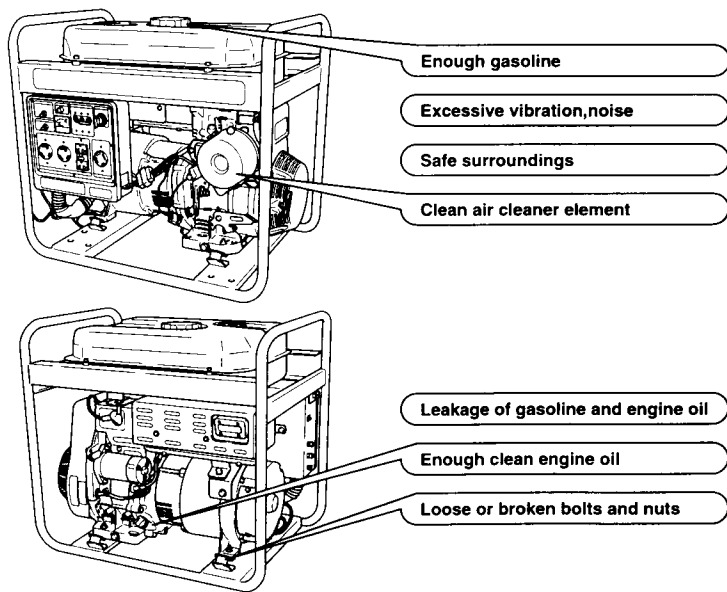

PERIODIC MAINTENANCE

Periodic maintenance is vital to safe and efficient operation of your generator.

Check the table below for periodic maintenance intervals.

It is also necessary for the user of this generator to conduct the maintenance and adjustments on the emission-related parts listed below to keep the emission control system effective.

The emission control system consists of the following parts :

- | | | |
|-----------------------------------|---|-------------------|
| (1) Carburetor and internal parts | (2) Choke system | (3) Fuel strainer |
| (4) Air cleaner elements | (5) Intake pipe | (6) Spark plug |
| (7) Magneto | (8) Fuel hoses, clamps, and sealing gaskets | |

The maintenance schedule indicated in the table is based on the normal generator operation. Should the generator be operated in extremely dusty condition or in heavier loading condition, the maintenance intervals must be shortened depending on the contamination of oil, clogging of filter elements, wear of parts, and so on.

	8 hours (daily)	20 hours (weekly)	50 hours	200 hours	500hours (monthly)	1000hours (24months)
CLEAN GENERATOR AND CHECK BOLT AND NUTS	X (daily)					
CHECK AND REFILL ENGINE OIL	X (Refill daily up to upper limit)					
CHANGE ENGINE OIL (*Note 1, 2)		X (Initial 20)	X			
CLEAN SPARK PLUG			X			
WASH AIR CLEANER ELEMENT			X			
CLEAN FUEL STRAINER				X		
CLEAN AND ADJUST SPARK PLUG GAP				X		
REPLACE SPARK PLUG					X	
REPLACE CLEANER ELEMENT (*Note 3)					X	
CLEAN VALVE SEAT ALONG WITH CYLINDER HEAD (*Note 3)					X	
REMOVE CARBON FROM CYLINDER HEAD (*Note 3)					X	
ADJUST VALVE CLEARANCE (*Note 3)					X	
CLEAN AND ADJUST CARBURETOR (*Note 3)					X	
INSPECT CONTROL PANEL PARTS (*Note 3)					X	
CHANGE FUEL LINES						X
CHECK ROTOR AND STATOR (*Note 3)						X
REPLACE ENGINE MOUNT RUBBER (*Note 3)						X
OVERHAUL ENGINE (*Note 3)						X

***NOTE: 1.** Initial oil change should be performed after first twenty (20) hours of operation. Thereafter change oil every fifty (50) hours. Before changing oil, check for a suitable way to dispose of old oil. Do not pour it down into sewage drains, onto garden soil or into open streams. Your local zoning or environmental regulations will give you more detailed instructions on proper disposal.

***NOTE: 2.** Change more often if used in dusty or dirty environments.

***NOTE: 3.** As to the procedures for these items, please consult your nearest Makita factory or authorized service center.

8. "HOW-TO" MAINTENANCE

ENGINE OIL CHANGE

- Change engine oil every 100 hours.
(For new engine, change oil after 20 hours.)

- (a) Drain oil by removing the drain plug and the oil filler cap while the engine is warm.
- (b) Reinstall the drain plug and fill the engine with oil until it reaches the upper level on the oil filler cap.

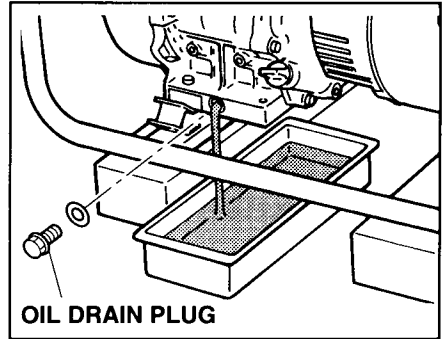

- Use fresh and high quality lubricating oil to the specified level as directed on page 6. If contaminated or deteriorated oil is used or the quantity of the engine oil is not sufficient, the engine damage will result and its life will be greatly shortened.

SERVICING THE AIR CLEANER

Maintaining an air cleaner in proper condition is very important.

Dirt induced through improperly installed, improperly serviced or inadequate elements damages and wears out engines. Keep the element always clean.

- (a) Unhook the cover and remove the cleaner element.
- (b) Inner element : Wash the element with kerosene, then soak it in mixed oil (Kerosene (3 parts) : Engine oil (1 part)). Drain the mixed oil.
- (c) Outer element : Wash the element with kerosene, then dip it into the mixed oil (Kerosene (3 parts) : Engine oil (1 part)). Squeeze out the mixed oil. (Do not twist.)

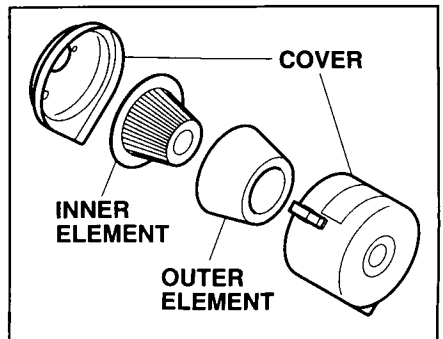
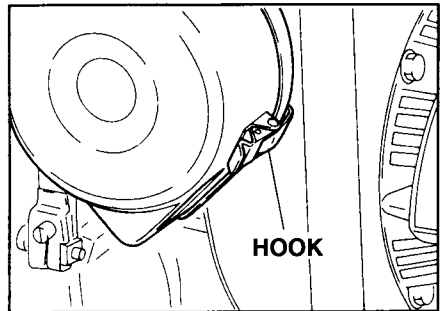

CLEANING AND ADJUSTING SPARK PLUG

- (a) If the plug is contaminated with carbon, remove it using a plug cleaner or wire brush.
- (b) Adjust the electrode gap to 0.024" to 0.028" (0.6 to 0.7 mm).

Model	Spark plug
G2800R G4100R, G4101R	NGK BR6HS
G6100R, G6101R	NGK BPR6ES

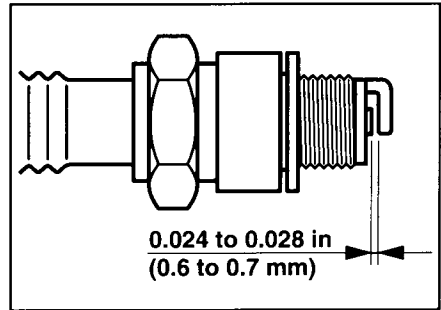

CLEANING FUEL STRAINER

Dirt and water in the fuel are removed by the fuel strainer.

- (a) Remove the strainer cup and throw away water and dirt.
- (b) Clean the screen and strainer cup with gasoline.
- (c) Tightly fasten the cup to main body, making sure to avoid fuel leak.

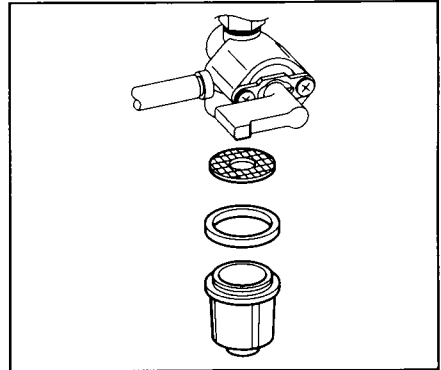

9. PREPARATION FOR STORAGE

The following procedures should be followed prior to storage of your generator for periods of 6 months or longer.

- Drain fuel from fuel tank carefully by disconnecting the fuel line.
Gasoline left in the fuel tank will eventually deteriorate making engine-starting difficult.
- Remove the carburetor float chamber and also drain the carburetor.
- Change engine oil.
- Check for loose bolts and screws, tighten them if necessary.
- Clean generator thoroughly with oiled cloth. Spray with preservative if available. **NEVER USE WATER TO CLEAN GENERATOR !**
- Pull starter handle until resistance is felt, leaving handle in that position.
- Store generator in a well ventilated, low humidity area.

10. TROUBLESHOOTING

When generator engine fails to start after several attempts, or if no electricity is available at the output socket, check the following chart. If your generator still fails to start or generate electricity, contact your nearest Makita factory or authorized service center for further information or corrective procedures.

When Engine Fails to Start :

Check if choke lever is in its proper position.		Set the choke lever to "CLOSE" position.
Check if fuel cock is open.	↔	If closed, open fuel cock.
Check fuel level.		If empty, refill fuel tank making sure not to overfill.
Check if engine switch is in OFF.		Turn engine switch to ON.
Check to make sure generator is not connected to an appliance.		If connected, turn off the power switch on the connected appliance and unplug.
Check spark plug for loose spark plug cap.	↔	If loose, push spark plug cap back into place.
Check spark plug for contamination.		Remove spark plug and clean electrode.

When No Electricity Is Generated at Receptacle :

Check to make sure no-fuse breaker is in the "ON" position.	↔	After making sure that the total wattage of the electrical appliance is within permissible limits and there are no defects in the appliance, turn the no-fuse breaker to the "ON" position. If breakers continue to actuate, consult your nearest servicing dealer.
Check AC and DC terminals for loose connection.		Secure connection if necessary.
Check to see if engine starting was attempted with appliances already connected to generator.	↔	Turn off switch on the appliance, and disconnect cable from receptacle. Reconnect after generator has been started properly.

11. WIRING DIAGRAM

G2800R

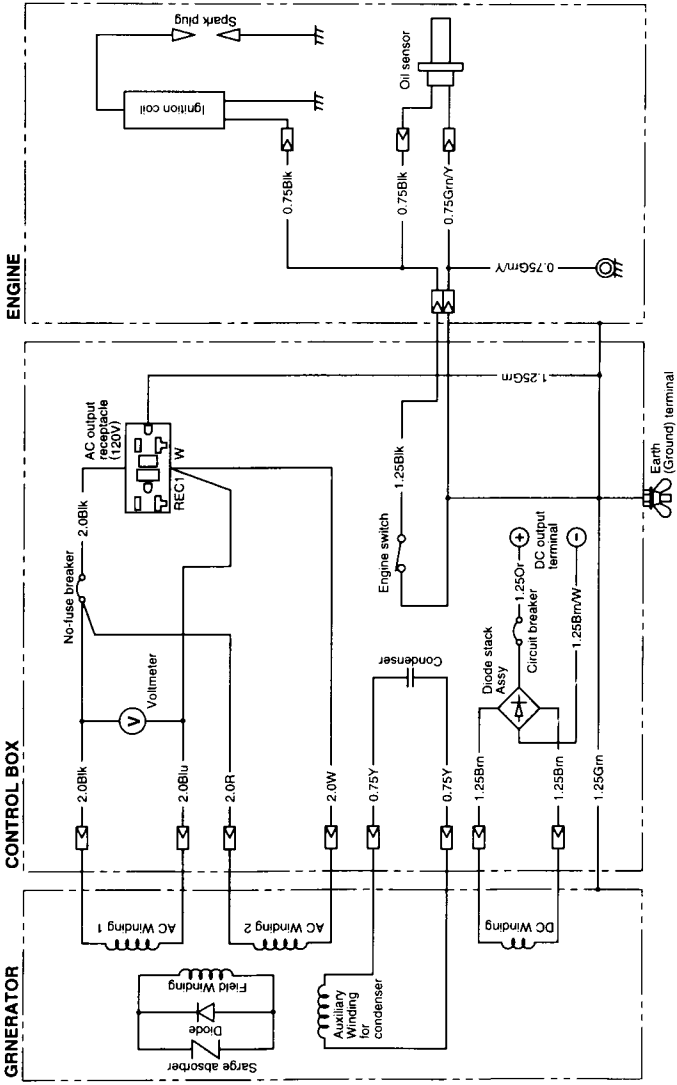

Wiring color cord

- | | | |
|---------------------|---------------------|------------|
| Blk : Black | Brn/W : Brown/White | R : Red |
| Blk/W : Black/White | Grn : Green | W : White |
| Blu : Blue | Grn/W : Green/White | Y : Yellow |
| LBlu : Light blue | Org : Orange | |
| Bm : Brown | Gry : Gray | |

G4100R

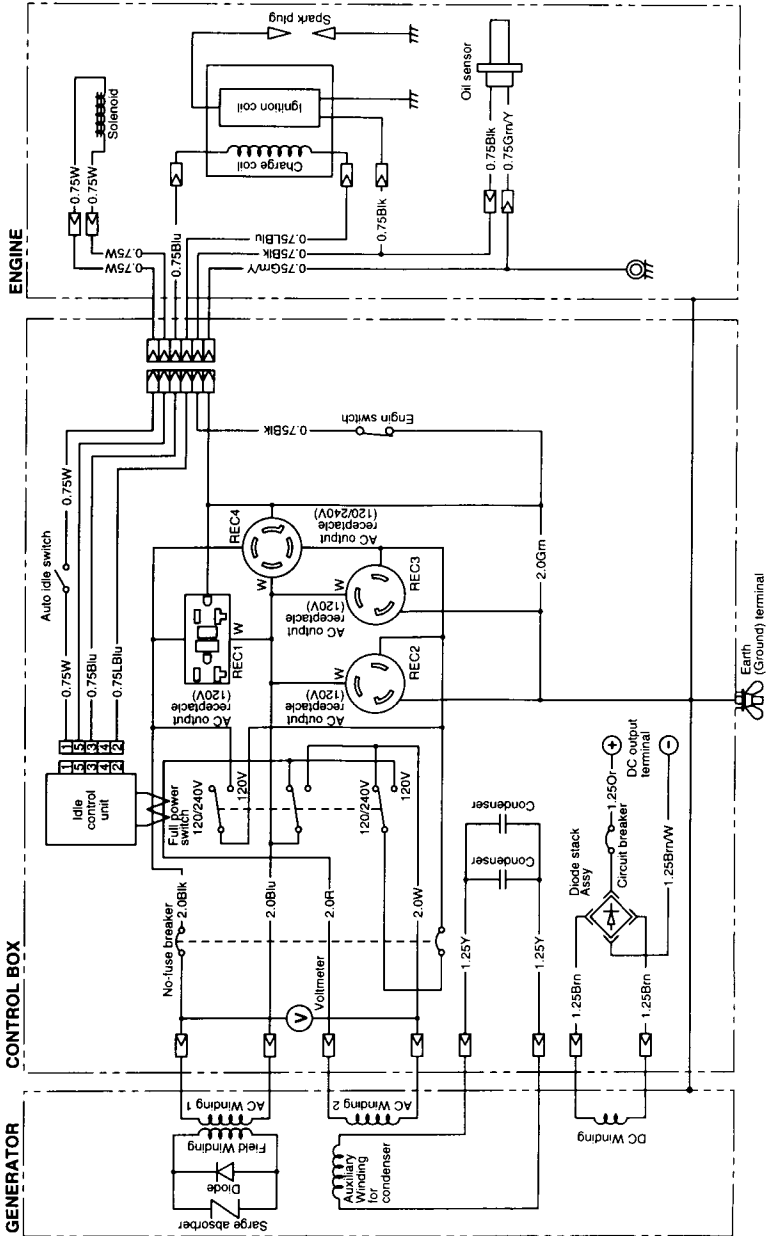

G4101R

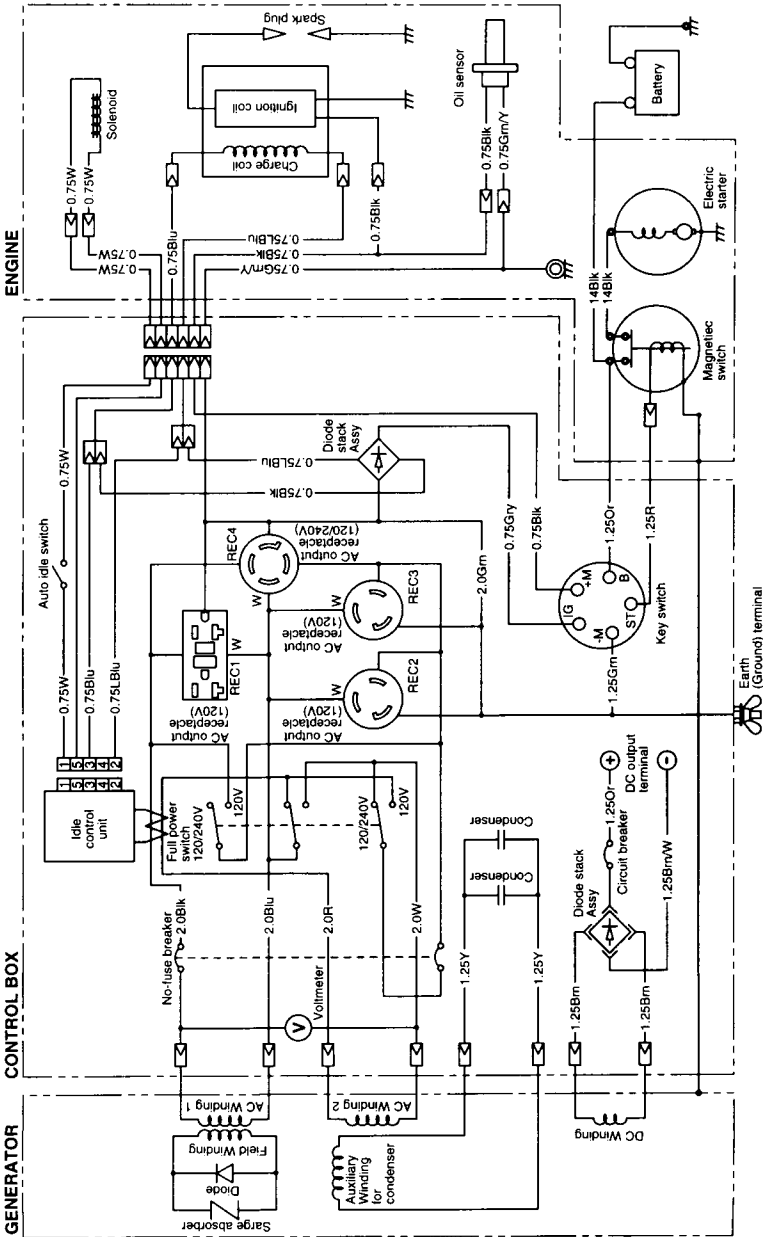

G6100R

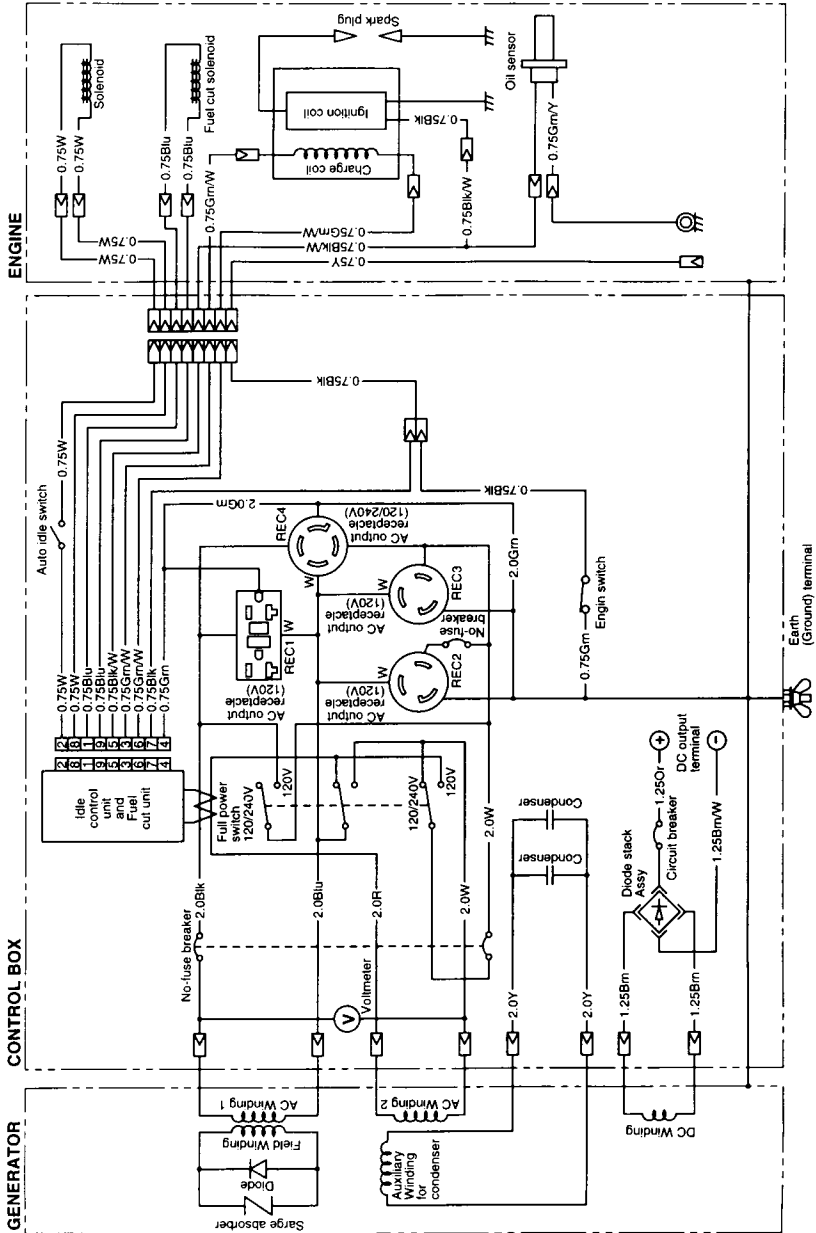

G6101R

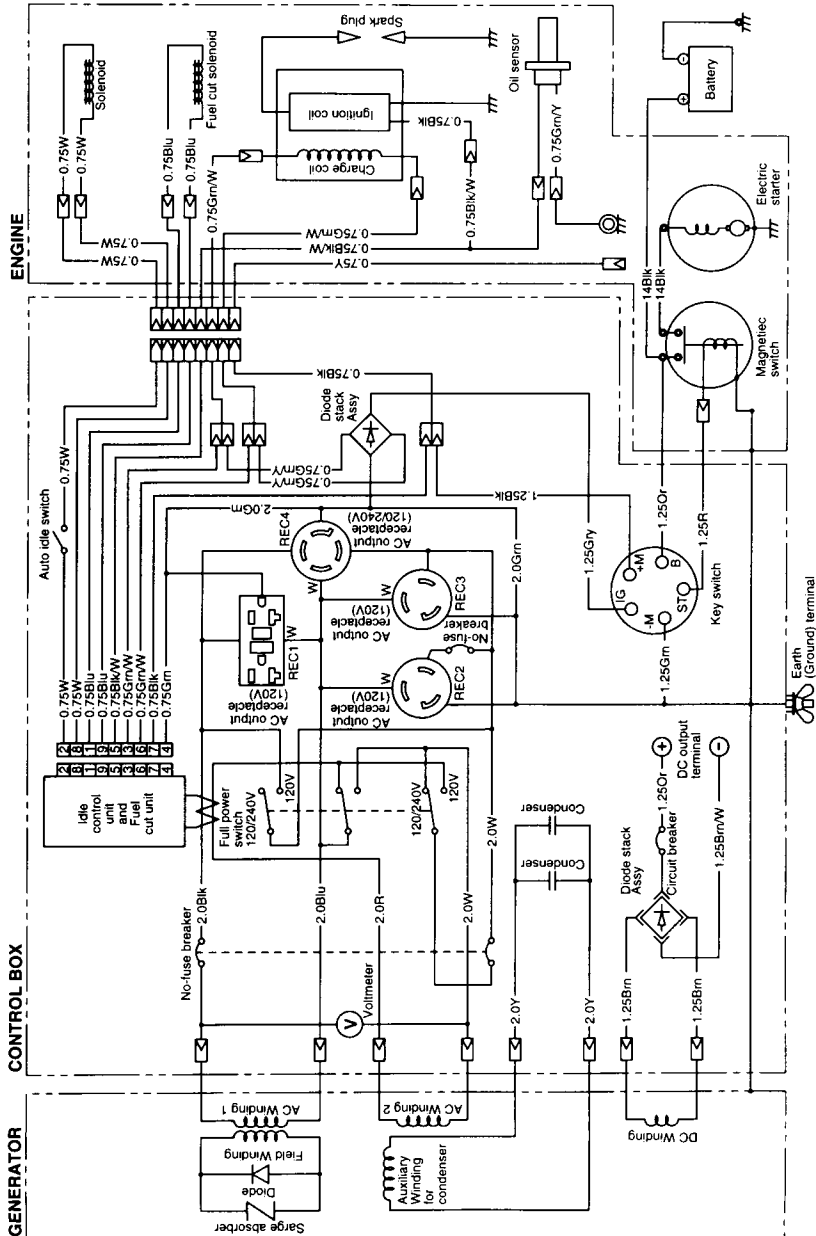

12. OPTIONAL PARTS

"HOW TO" INSTALL BATTERY

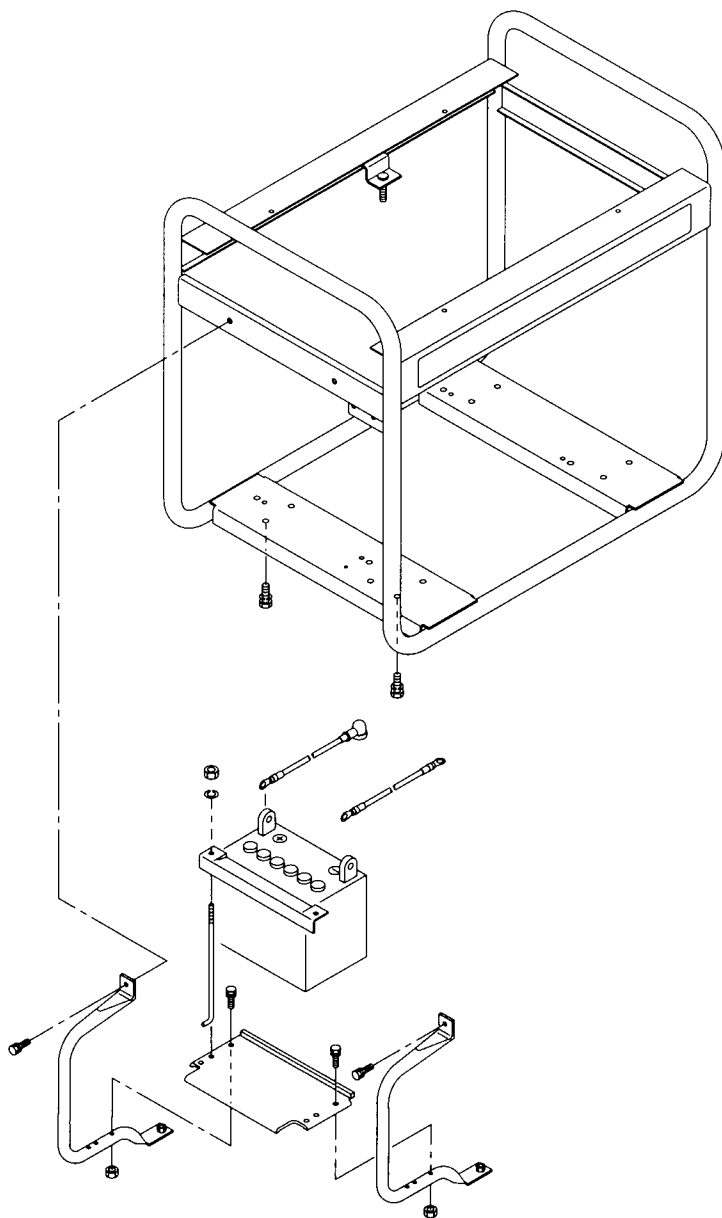

MAKITA LIMITED ONE YEAR WARRANTY

Warranty Policy

Every Makita tool is thoroughly inspected and tested before leaving the factory. It is warranted to be free of defects from workmanship and materials for the period of ONE YEAR from the date of original purchase. Should any trouble develop during this one-year period, return the COMPLETE tool, freight prepaid, to one of Makita's Factory or Authorized Service Centers. If inspection shows the trouble is caused by defective workmanship or material, Makita will repair (or at our option, replace) without charge.

This Warranty does not apply where:

- repairs have been made or attempted by others;
- there is evidence of normal wear and tear;
- The tool has been abused, misused or improperly maintained;
- alterations have been made to the tool.

Defects are due to the use of parts, accessories or attachments which are not Makita genuine products, specifically recommended for use with this tool.

Damage may be caused in transit. (This must be the responsibility of the carrier.) Claims arise from regulations such as for noise levels, exhaust gas emissions, etc. This product has been operated for racing purposes or other competitive activities. This product has been employed for powering equipment that is operated on, in or near water or explosive atmospheres.

The following parts are expendable (not durable), so warranty does not apply:

Expendable parts including, but not limited to:

Spark plugs, packings, gaskets, rubber materials, washers, nuts, V-belt, engine oil, grease, paper elements, brushes, mechanical seal, pump impeller and volute casing.

IN NO EVENT SHALL MAKITA BE LIABLE FOR ANY INDIRECT, INCIDENTAL OR CONSEQUENTIAL DAMAGES FROM THE SALE OR USE OF THE PRODUCT. THIS DISCLAIMER APPLIES BOTH DURING AND AFTER THE TERM OF THIS WARRANTY.

MAKITA DISCLAIMS LIABILITY FOR ANY IMPLIED WARRANTIES, INCLUDING IMPLIED WARRANTIES OF "MERCHANTABILITY" AND "FITNESS FOR A SPECIFIC PURPOSE," AFTER THE ONE-YEAR TERM OF THIS WARRANTY.

This Warranty gives you specific legal rights, and you may also have other rights which vary from state to state. Some states do not allow the exclusion of limitation of incidental or consequential damages, so the above limitation or exclusion may not apply to you. Some states do not allow limitation on how long an implied warranty lasts, so the above limitation may not apply to you.

Makita Corporation

3-11-8, Sumiyoshi-cho

Anjo, Aichi 446 Japan

PRINTED IN JAPAN

Free Manuals Download Website

<http://myh66.com>

<http://usermanuals.us>

<http://www.somanuals.com>

<http://www.4manuals.cc>

<http://www.manual-lib.com>

<http://www.404manual.com>

<http://www.luxmanual.com>

<http://aubethermostatmanual.com>

Golf course search by state

<http://golfingnear.com>

Email search by domain

<http://emailbydomain.com>

Auto manuals search

<http://auto.somanuals.com>

TV manuals search

<http://tv.somanuals.com>