

# TECHNICAL INFORMATION

**Model No.** ▶ HR2600/ HR2601

**Description** ▶ Rotary Hammers 26mm (1")

## CONCEPT AND MAIN APPLICATIONS

HR2600/ HR2601 are 26mm (1") 2-mode rotary hammers adapted for SDS-PLUS bits, featuring compact and lightweight design, enhanced comfort and better control with ergonomic handle. Model HR2601 is equipped with AVT; Anti Vibration Technology consisting of Active dynamic vibration absorber with counterweight and Damper spring. AVT ensures operation with extremely low vibration, which is much superior to the competitors. HR2600 series models are available in the variations listed below, including HR2300 and HR2610 series models developed on the same concept.

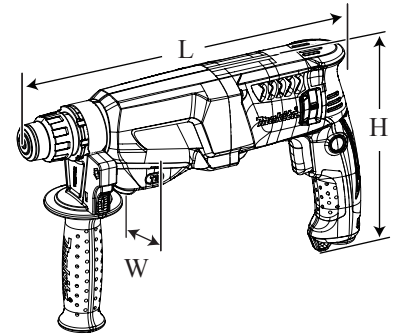

Model	Capacity	Operation Mode	AVT	LED	Chuck type
HR2300	23mm	2 modes (Rotation only/ Rotation with hammering)	No	No	Adapted for SDS-PLUS shank bits
HR2600	26mm		No	No	
HR2601		Yes	No		
HR2610		No	No		
HR2611F		3 modes (Rotation only/ Rotation with hammering/ Hammering only)	Yes	Yes	Adapted for SDS-PLUS shank bits and Round shank bits*
HR2310T	23mm	No	No		
HR2610T	26mm	No	No		
HR2611FT		Yes	Yes		

Dimensions: mm (")	
Length (L)	361 (14-1/4)
Width (W)	77 (3)
Height (H)	209 (8-1/4)

\*Round shank bits can also be used by replacing the factory-mounted chuck with **Quick change drill chuck** (keyless).

For information of HR2300 and HR2610 series models, see "TECHNICAL INFORMATION" of each series.

## Specification

Voltage (V)	Current (A)	Cycle (Hz)	Continuous Rating (W)		Max. Output (W)
			Input	Output	
110	7.7	50/ 60	800	400	550
120	7	50/ 60	---	400	550
127	6.6	50/ 60	800	400	550
220	3.8	50/ 60	800	400	550
230	3.7	50/ 60	800	400	550
240	3.5	50/ 60	800	400	550

Specification	Model	HR2600/ HR2601	
No load speed: min <sup>-1</sup> = rpm		0 - 1,200	
Impacts per minute= min <sup>-1</sup>		0 - 4,600	
Chuck type		Adapted for SDS-PLUS shank bits	
Capacities: mm (")	Concrete	TCT bit	26 (1)
		Core bit	68 (2-11/16)
		Diamond core bit	80 (3-1/8)
	Steel	13 (1/2)	
	Wood	32 (1-1/4)	
Operation mode		2 modes (Rotation only/ Rotation with Hammering)	
Vibration absorption		No/ Yes (AVT*1)	
Variable speed control		Yes (by trigger)	
Rotation reversing facility		Yes	
Torque limiter		Yes	
LED Job light		No	
Double insulation		Yes	
Power supply cord: m (ft)		Europe, North America: 4.0 (13.1), Australia, Brazil: 2.0 (6.6), Other countries: 2.5 (8.2)	
Weight according to EPTA-Procedure 01/2003*2: kg (lbs)		2.8/ 2.9 (6.2/ 6.3)	

\*1 AVT (Anti Vibration Technology); Counterweight mechanism + Damper spring

\*2 with side grip

## ▶ **Standard equipment**

Depth gauge .....	1
Side grip .....	1
Dust cup set .....	1 <b>(for some countries only)</b>
Plastic carrying case .....	1

**Note:** The standard equipment for the tool shown above may vary by country.

## ▶ **Optional accessories**

SDS-PLUS shank TCT hammer drill bits	Dust cups 5 and 9
Taper shank TCT hammer drill bits	Hose
Taper shank adaptor	Joint 25
Cotter	Dust cup set
Core bits	Plastic carrying case
Center bits	Hammer grease (30g)
Core bit adaptor	Bit grease
Rod	Depth gauge
Drill chuck ass'y	Blow out bulb
Chuck adapter assembly	Safety goggles
Drill chuck S13	Bull points
Chuck key S13	Cold chisels
Tool holder set	Scaling chisels
Scraper assembly	Grooving chisels
Waterproof cover	Hammer service kit
Quick change drill chuck (keyless)	

## ► Repair

**CAUTION:** Repair the machine in accordance with “Instruction manual” or “Safety instructions”.

### [1] NECESSARY REPAIRING TOOLS

Code No.	Description	Use for
1R003	Retaining ring S pliers ST-2N	removing Ring spring 14 and Ring spring 15 from Tool holder complete
1R026	Bearing setting pipe 16-8.2	assembling Bearing box
1R028	Bearing setting pipe 20-12.2	removing Helical gear 26
1R033	Bearing setting plate 10.2	
1R035	Bearing setting plate 15.2	
1R045	Gear extractor (large)	removing/ assembling Spiro lock washer 30
1R164	Ring spring setting tool A	assembling Oil seal 25
1R212	Tip for retaining ring pliers	Use with 1R003
1R228	1/4" Hex. shank bit for M4	removing M4 Hex socket head bolt
1R232	Pipe 30	assembling Oil seal 25
1R252	Round bar for arbor 30-100	removing Oil seal 25
1R258	V block	assembling Oil seal 25
1R269	Bearing extractor	removing Ball bearing 6000LLB / 627DDW
1R273	Ring spring 26 setting tool B	removing Cup sleeve / Ball bearing 6806LLU
1R281	Round bar for arbor 7-50	removing Helical gear 26
1R369	Jig for Spiro lock washer	removing/ assembling Spiro lock washer 30
1R388	Ring spring extractor	removing Ring spring 28

► **Repair**

**[2] LUBRICATION**

Apply the following grease/ lubricant to protect parts and product from unusual abrasion.

Item No.	Description	Portion to lubricate	Grease/ Lubricant	Amount	
①	Cap 35	Lip portion where Bit is to be inserted	Makita grease RB No. 00 ◀	a little	
①⑥	Gear housing complete	Oil seal 25 on the inside of Gear housing complete			
②①	Push corn	Portion that contacts Clutch cam B			
②①	Compression spring 5	Periphery			
②③	O ring 21	Entire surface	Makita lubricating oil VG100 ◀	a little	
②⑥	Steel ball 7.0 (2 pcs.)	Entire surface	Makita grease RB No. 00 ◀		
②⑧	Tool holder complete	(a) Periphery that contacts Driving flange/ Spur gear 51 (b) Inside where ④⑥ Piston cylinder reciprocates			
②⑨	Driving flange	Portion that contacts ③① Spur gear 51/ Pins 6			
③②	Flat washer 30	Portion that contacts ③① Spur gear 51/ Pins 6			
③⑥	Flat washer 30	Portion that contacts Inner housing complete			
③⑧	Impact bolt	Entire surface			
④②	O ring 9	Entire surface			
④④	Striker	Entire surface			
④⑤	O ring 17.5	Entire surface			
③①	Spur gear 51	Gear portion			
④⑥	Piston cylinder	(c) Inside where ④④ Striker moves (d) Periphery that ②⑧ Tool holder complete contacts			
④⑦	Guide plate	Inside that contacts ④⑧ Piston joint			
⑤⑥	Spur gear 10	(e) Gear portion (f) Portion that contacts ⑤⑧ Swash bearing 10			
⑤⑧	Swash bearing 10	(g) Interleaved portion to Piston joint (h) Ball bearing portion			
⑥④	Helical gear 26	Gear portion that engages with Armature gear shaft	Makita lubricating oil VG100 ◀	a little	
⑥⑤	O-ring 68	Whole portion			
⑦①	O ring 26				
⑦①	Oil seal 12	Portion that contacts Sleeve 9			
④①	HR2601 only	Compression spring 20	Periphery that contacts ②⑧ Tool holder complete	Makita grease RB No. 00 ◀	a little

**Fig. 1**

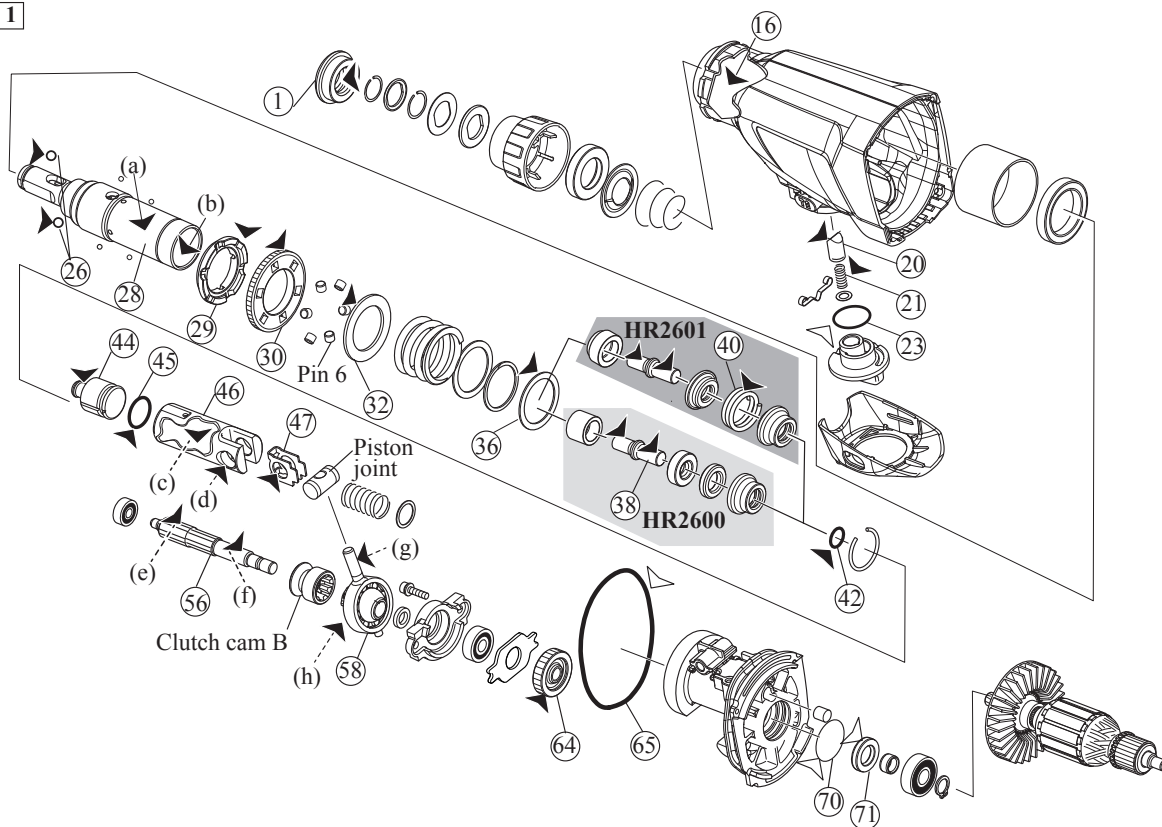

► **Repair**

**[3] DISASSEMBLY/ASSEMBLY**

**[3]-1. Bit holder section**

**DISASSEMBLING**

- (1) Remove Cap 35.
- (2) Separate Ring spring 14 from the groove of Tool holder complete using 1R003 with 1R212. (Fig. 2)  
Washer 16 on Ring spring 15 is removed.
- (3) Remove Ring spring 15 in the same way while pressing down Chuck cover. (Fig. 3) Then pick up Flat washer 17 and Rubber washer 16 from the space between Chuck cover and Tool holder complete. Chuck cover is removed.
- (4) Remove two Steel balls 7.0 while pressing down Ring 21. (Fig. 4)  
Ring 21, Guide washer and Conical compression spring 21-29 are removed.

**Fig. 2**

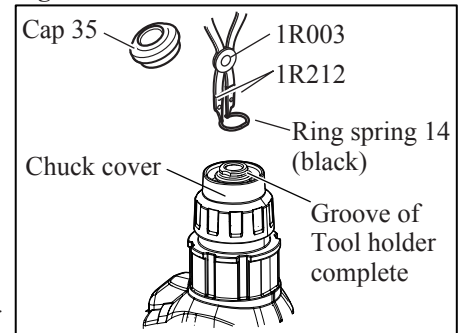

**Fig. 3**

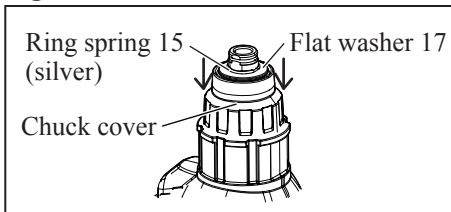

**Fig. 4**

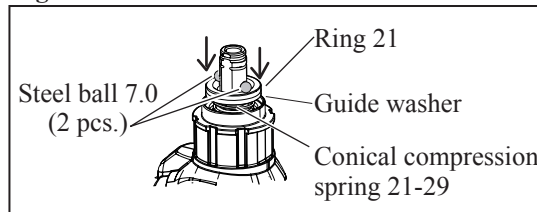

**ASSEMBLING**

Assemble in the reverse order of disassembly. Refer to Fig. 5 for the directions of the components.

**Fig. 5**

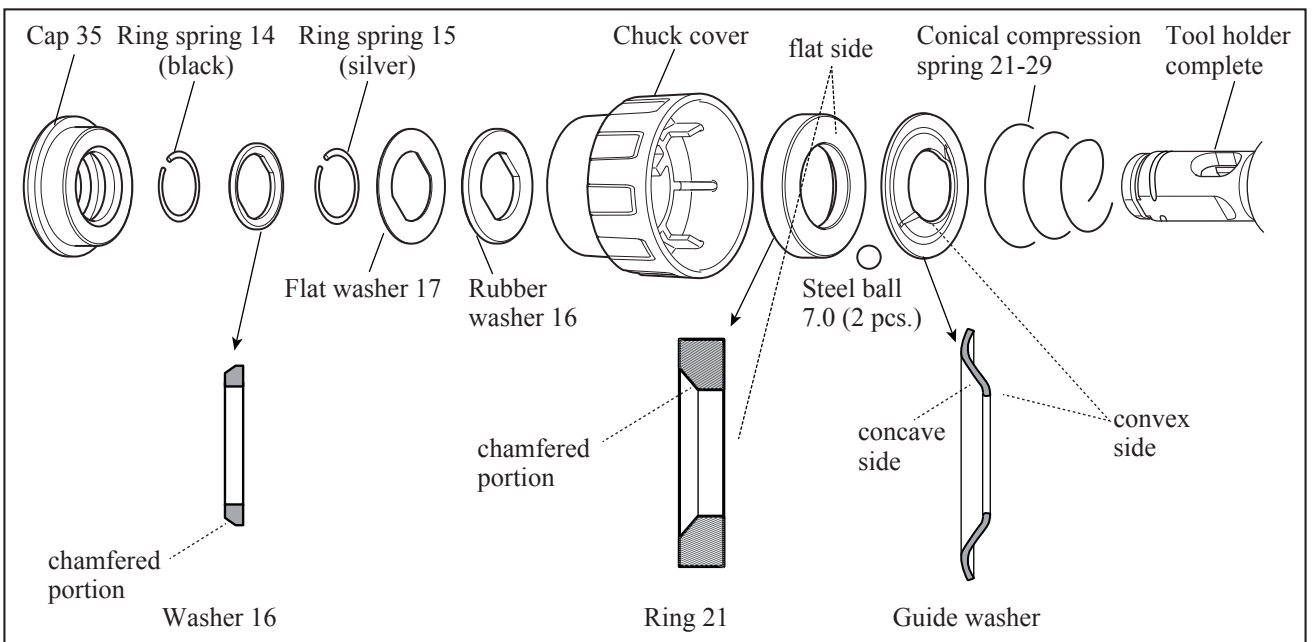

## ► Repair

### [3] DISASSEMBLY/ASSEMBLY

#### [3]-3. Change lever section

##### DISASSEMBLING

Insert the tip of thin slot screwdriver into the notch of Gear housing complete, then lever up one side of Change lever cover B. (Fig. 6)

Lever up the other side of Change lever cover B in the same way, then remove Change cover lever B. Change lever B can be removed.

##### ASSEMBLING

(1) Set Change lever B to 45° position as drawn in Fig. 7.

(2) While checking the V-edge of Push corn fits into V-groove of Clutch cam B, insert Change lever B into Gear housing.

(3) After turning Change lever B to hammer drill mode position, put Change lever cover B on Change lever B.

**Note:** The V-groove of Change lever B has to come on the center of Leaf spring. (Fig. 8)

(4) Be sure to check Change lever B works properly after assembling.

Fig. 6

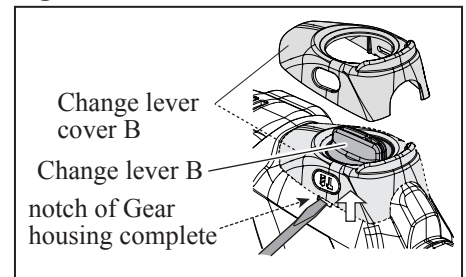

Fig. 7

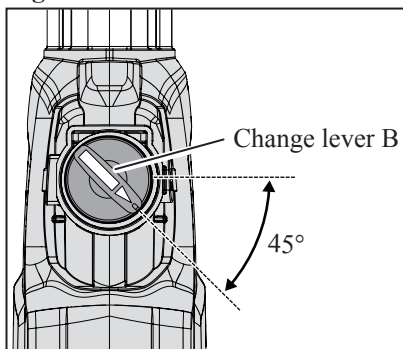
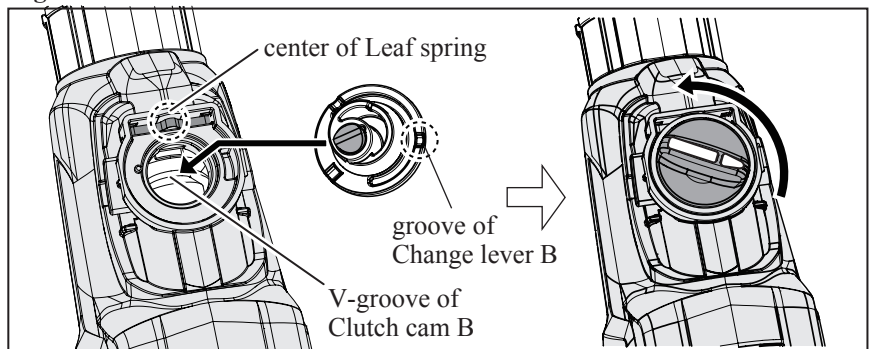

Fig. 8



#### [3]-4. Armature

##### REPLACING

(1) Remove three 4x18 Tapping screws and Handle cover.

(2) Slide Brush holder unit to the best position to repair, and move the arms of Spiral springs aside, then separate Carbon brushes from Commutator. (Fig. 9)

(3) Remove four 4x30 Tapping screws then separate Motor housing from Gear housing complete. Armature is left on Gear housing at that time. (Fig. 10)

**Note:** Do not lose Wave washer 15 on the bottom of Motor housing. Do not fail to set it in place when assembling.

(4) Remove Armature ass'y from Gear housing complete by pulling by hand.

**Note:** Ball bearing 6000LLB of Armature ass'y is held in Inner housing complete with O ring 26. Therefore, it is not necessary to tap Gear housing complete with Plastic hammer to remove Armature ass'y.

(5) Remove Ball bearings 6000LLB with 1R269.

Remove 627DDW and Insulation washer together at one time with 1R269.

(6) Assemble the components in the reverse order of disassembly after replacing the damaged parts.

Fig. 9

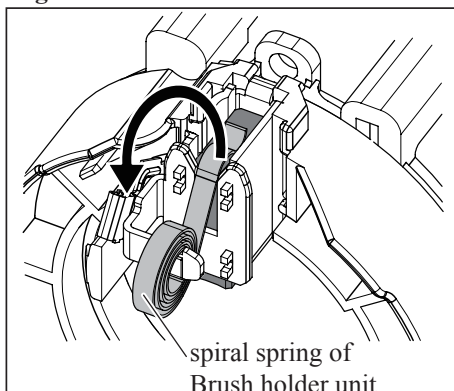
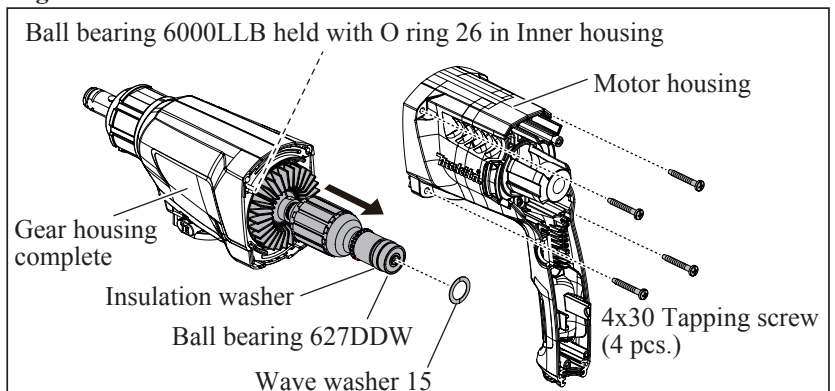

Fig. 10





# ► Repair

## [3] DISASSEMBLY/ASSEMBLY

### [3]-5. Torque limiter section

#### REPLACING

- (1) Remove Bit holder section.
  - (2) Remove Change lever section.
  - (3) Separate Gear housing from Motor housing.
  - (4) Remove Tool holder complete by tapping the top as drawn in **Fig. 11**.
- Note:** Flat washer 30 is located between Tool holder complete and Inner housing complete. Be careful to lose it.
- (5) Set 1R045 and 1R369 to Tool holder complete. (**Fig. 12**)
  - (6) Compress Compression spring 32 (**Fig. 13**), then separate Spiro lock washer 30 from Tool holder complete by sliding a thin slotted screwdriver from the upper end as drawn in **Fig. 14**. The components are disassembled. (**Fig. 15**)

**Fig. 11**

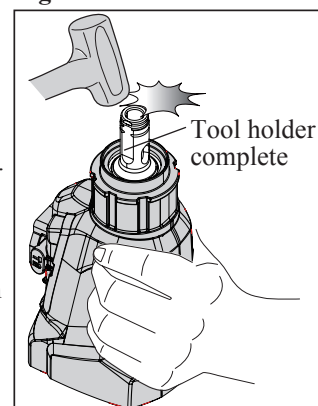

**Fig. 12**

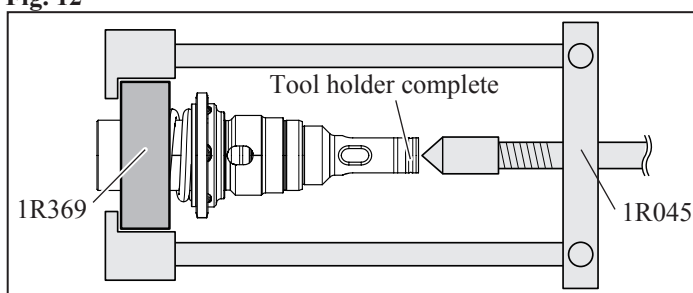

**Fig. 13**

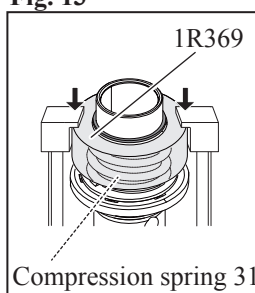

**Fig. 14**

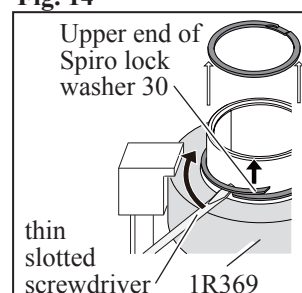

**Fig. 15**

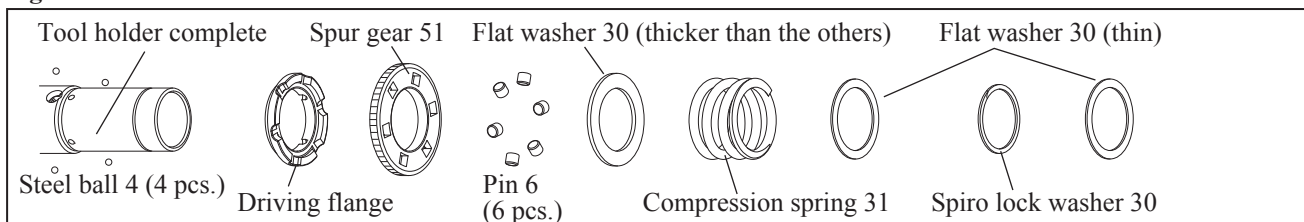

► **Repair**

**[3] DISASSEMBLY/ASSEMBLY**

**[3]-6. Impact bolt in Tool holder complete**

**DISASSEMBLING**

- (1) Put 1R388 into Tool holder complete then push 1R388 in vise with the access holes on Tool holder complete parallel to Vise. (**Fig. 16**)  
O-ring case A/ B is moved toward the top of Tool holder complete, and therefore, Ring spring 28 can be relieved from O-ring case A/ B.
- (2) When the end gap of Ring spring 28 is in the access hole, slide it with slotted screwdriver until it is completely hidden.
- (3) Using slotted screwdriver, tap Ring spring 28 through the two access holes alternately to push it out of the inner groove of Tool holder complete.
- (4) The components are removed by tapping with phillips screwdriver and plastic hammer from bit installation side of Tool holder complete. (**Fig. 17**)

**Fig. 16**

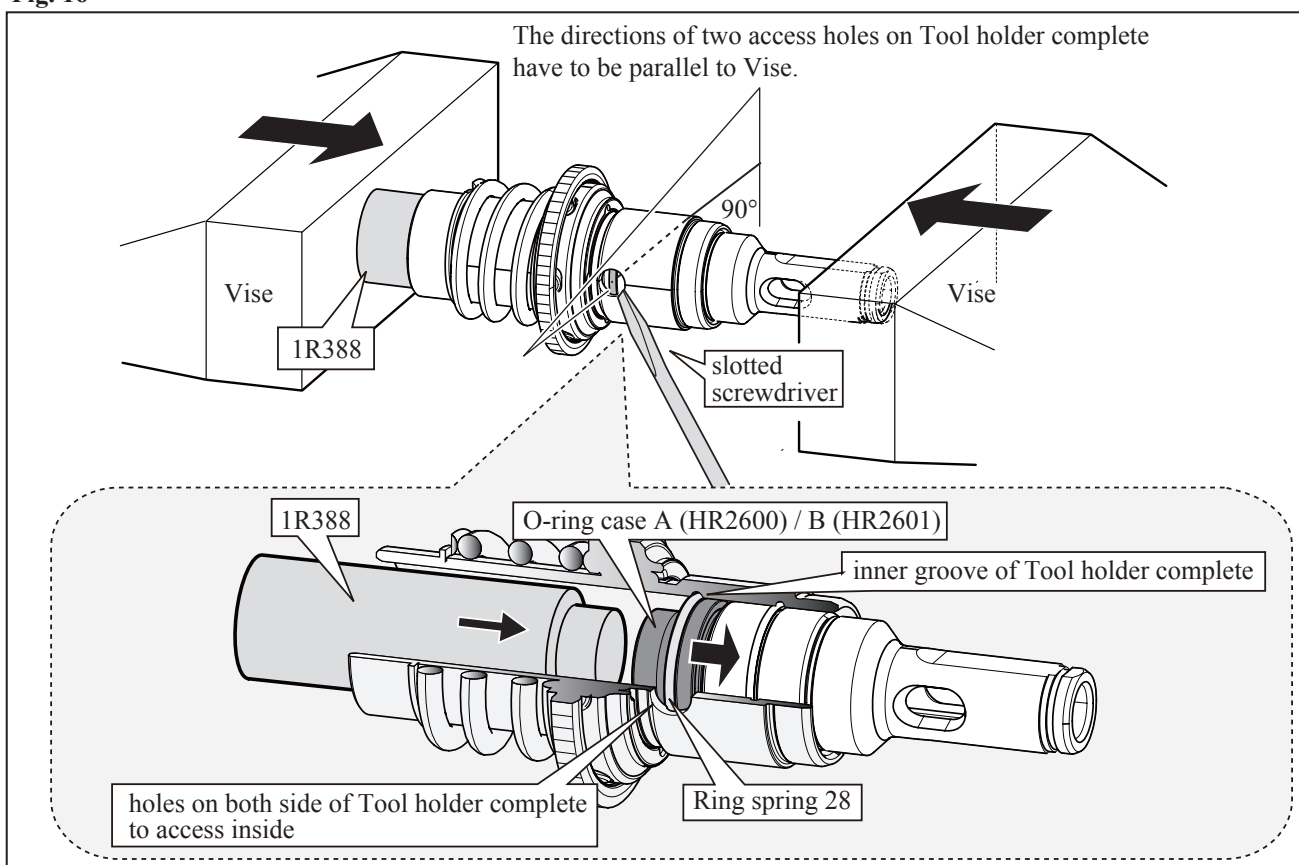

**Fig. 17**

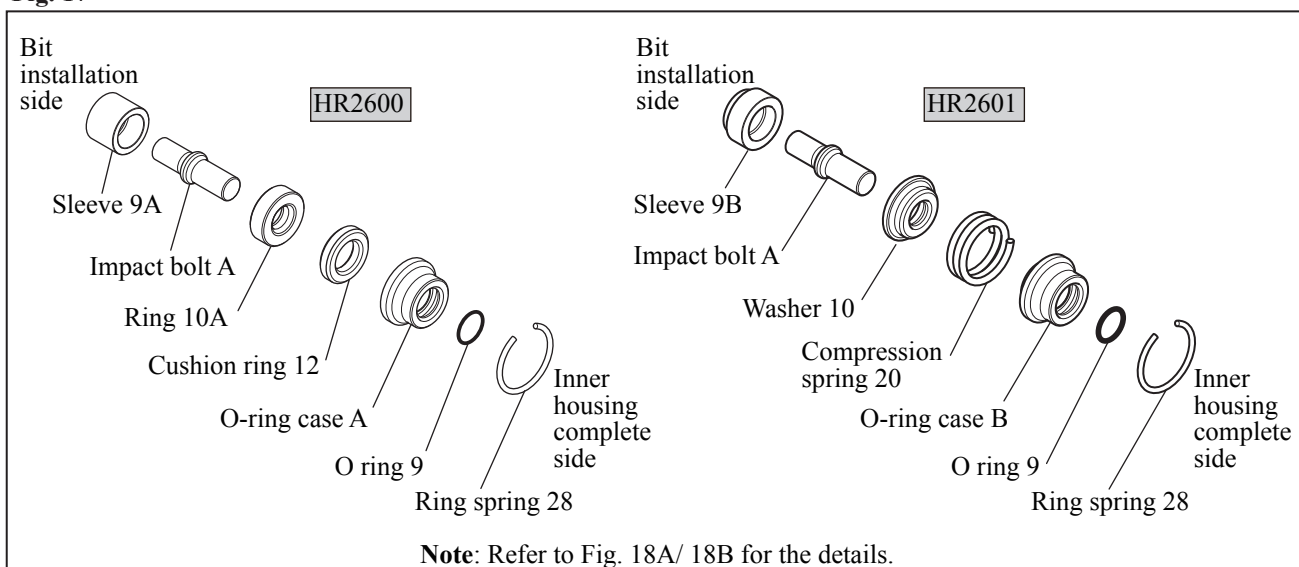



► **Repair**

**[3] DISASSEMBLY/ASSEMBLY**

**[3]-6. Impact bolt section in Tool holder complete (cont.)**

**ASSEMBLING**

(1) Assemble Impact bolt section to Tool holder complete as drawn in **Fig. 18A/ 18B**.

**Fig. 18A**

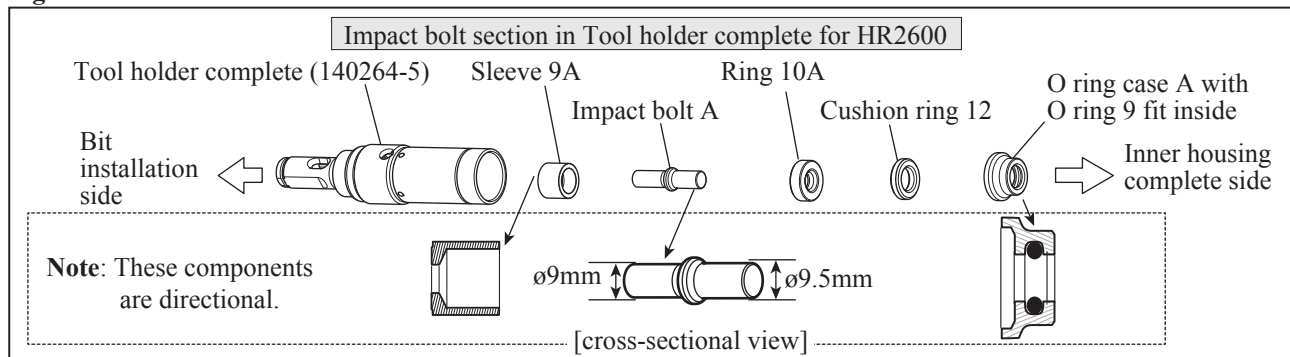

**Fig. 18B**

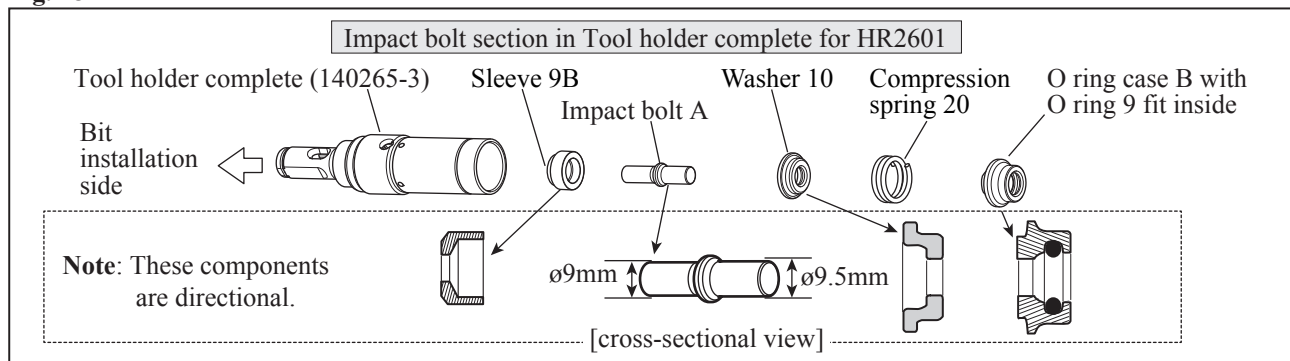

(2) Push Ring spring 28 into the inner groove of Tool holder complete as drawn in **Fig. 19**.

**Note:** Do not reuse the removed Ring spring 28 if it is deformed or damaged.

**Fig. 19**

**Note:** 1. Use an extra Piston cylinder as a jig. Never use Piston cylinder that is to be assembled to the machine.  
 2 2 The end gap of Ring spring 28 must not be located at the two holes of Tool holder complete.

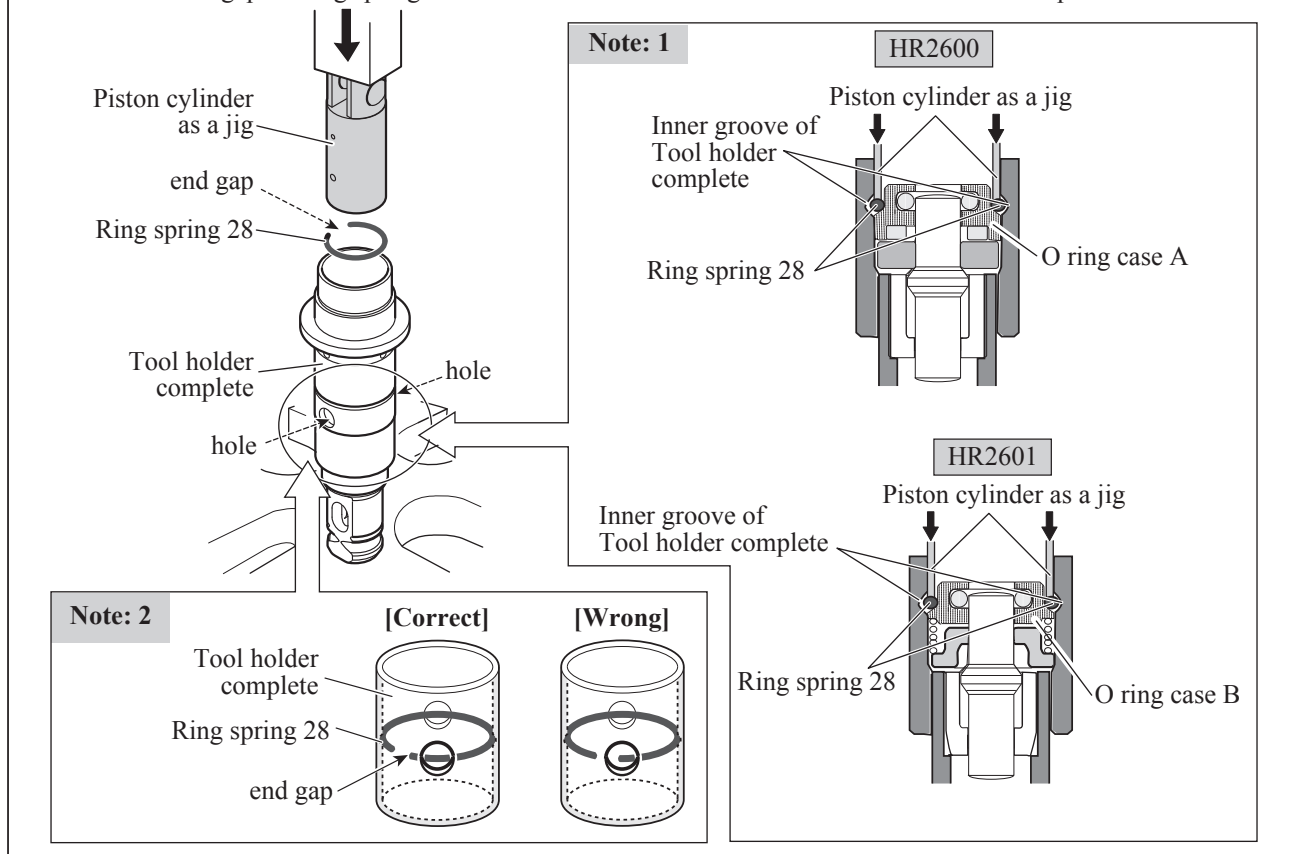

► **Repair**

**[3] DISASSEMBLY/ASSEMBLY**

**[3]-7. Swash bearing section**

**DISASSEMBLING**

- (1) Disassemble Motor housing section, Gear housing section and Inner housing section. As for HR2601, remove two M4x12 Hex socket head bolts. And then separate Counter weight section from Inner housing complete. (Fig. 20)
  - (2) Remove two M4x16 Hex socket head bolts with hex wrench 3 and 1R228. (Fig. 21)  
Then pull Swash bearing section out of Inner housing complete. (Fig. 22)
  - (3) Remove Ball bearing 606ZZ from Gear housing complete using the removed Swash bearing section. (Fig. 23)
  - (4) Receive Clutch cam B on 1R035 and press Spur gear 10 out of Clutch cam B.
- The swash bearing section can be removed as drawn in Fig. 24.

**Fig. 20**

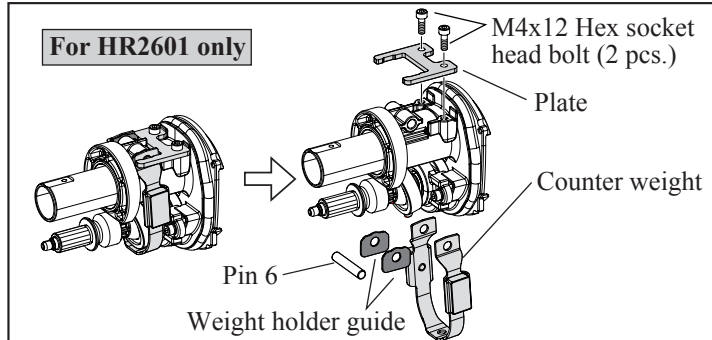

**Fig. 21**

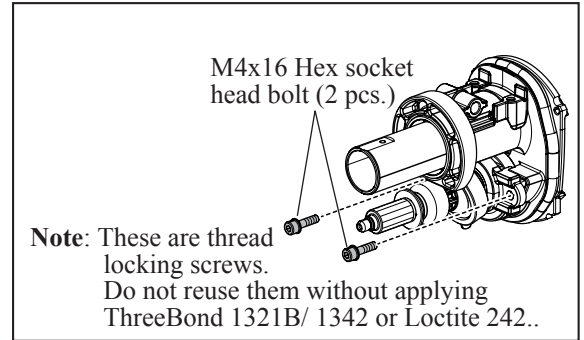

**Fig. 22**

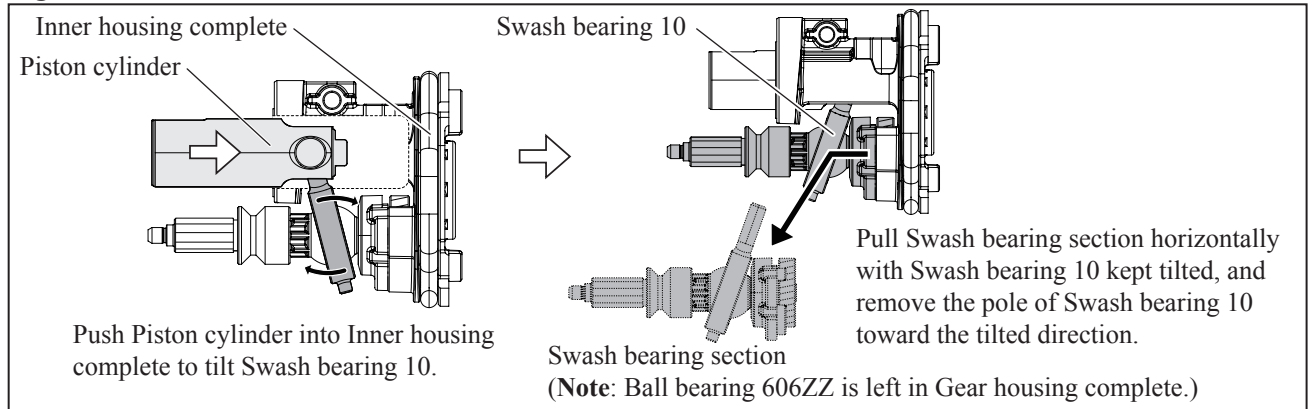

**Fig. 23**

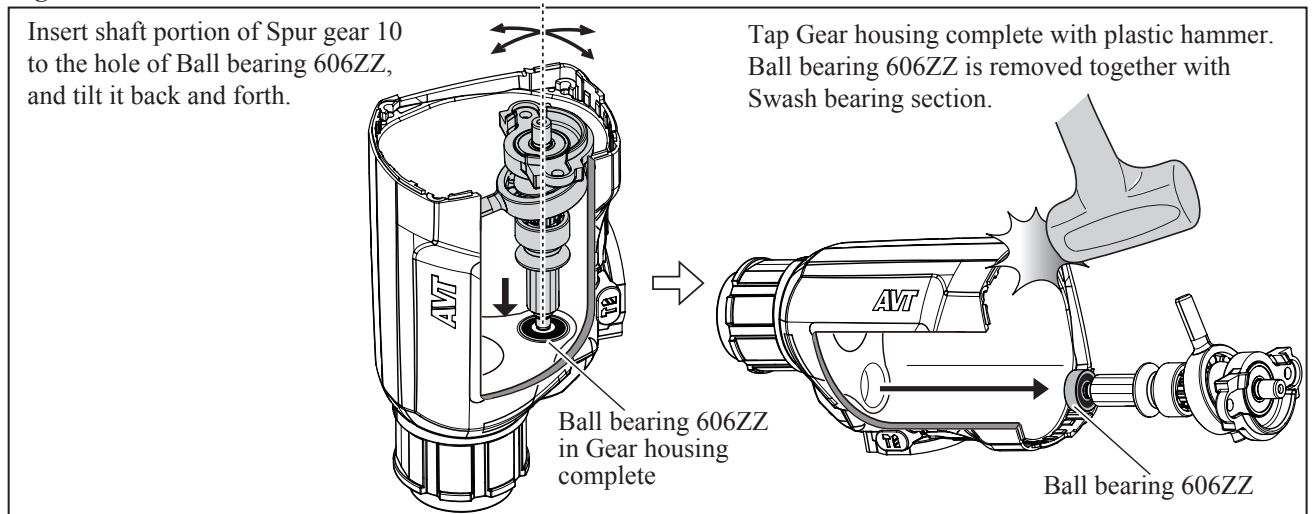

**Fig. 24**

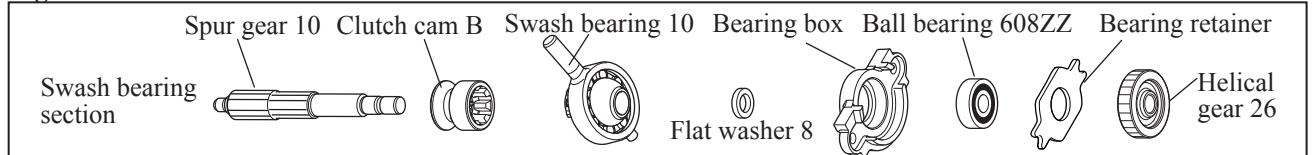

► **Repair**

**[3] DISASSEMBLY/ASSEMBLY**

**[3]-7. Swash bearing section (cont.)**

**ASSEMBLING**

- (1) Pressfit Ball bearing 608ZZ into Bearing box.
- (2) Put Clutch cam B, Swash bearing 10, Flat washer 8 and Bearing box to Spur gear 10 in order, then secure them using 1R033, 1R026 and arbor press.
- (3) Fit Bearing retainer in Bearing box, then pressfit Helical gear 26 to the shaft of Swash bearing section. Be careful of the directions of Bearing box and Helical gear 26. **(Fig.25)**

**Fig. 25**

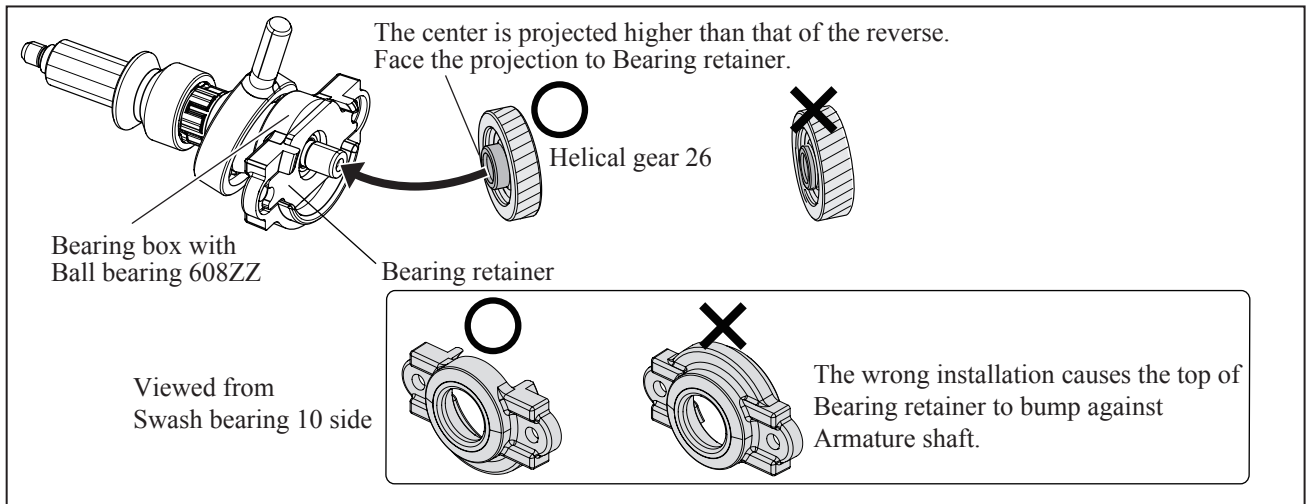

**[3]-8. How to assembly of Piston cylinder section to Swash bearing section**

- (1) Assemble Guide plate and Piston joint to Piston cylinder. Align the holes of Piston joint to the installed direction of Swash bearing 10. **(Fig. 26)**
- (2) Set Flat washer 14 and Compression spring 14 on the boss of Inner housing complete. **(Fig. 26)**
- (3) Put the opposite end of Compression spring 14 on Guide plate, then push Piston cylinder into the bottom of Inner housing complete and insert the pole of Swash bearing 10.
- (4) Assemble Striker with O ring 17.5 to Piston cylinder. Refer to **Fig 1**.

**Fig. 26**

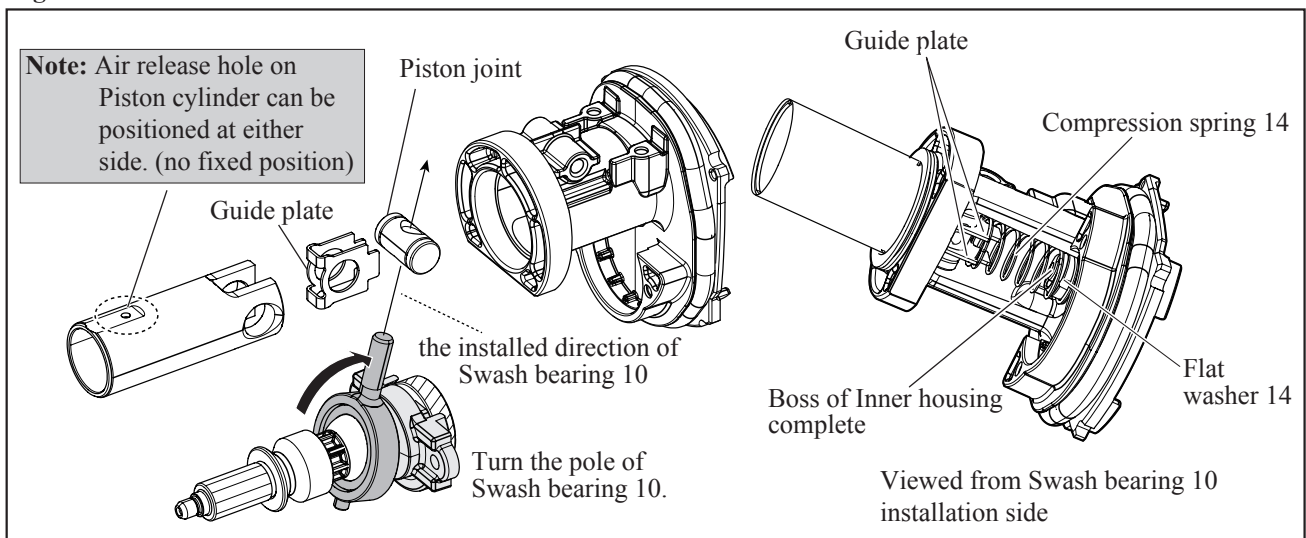

**[3]-9. How to assemble Gear housing to Inner housing**

- (1) Check that Clutch cam B is engaged with Swash bearing 10. **(Fig. 27)**
- (2) Assemble Gear housing complete to Inner housing complete.

**Fig. 27**

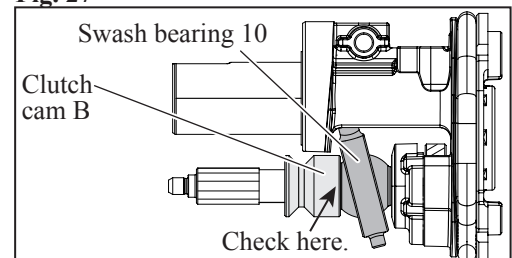

# ► Repair

## [4] Maintenance program

It is recommended to replace the following parts at the same time when replacing Carbon brushes. (Fig. 28)

**Note:** Be sure to put Makita grease RB No. 00 to the specific portions. (Fig. 1)

Fig. 28

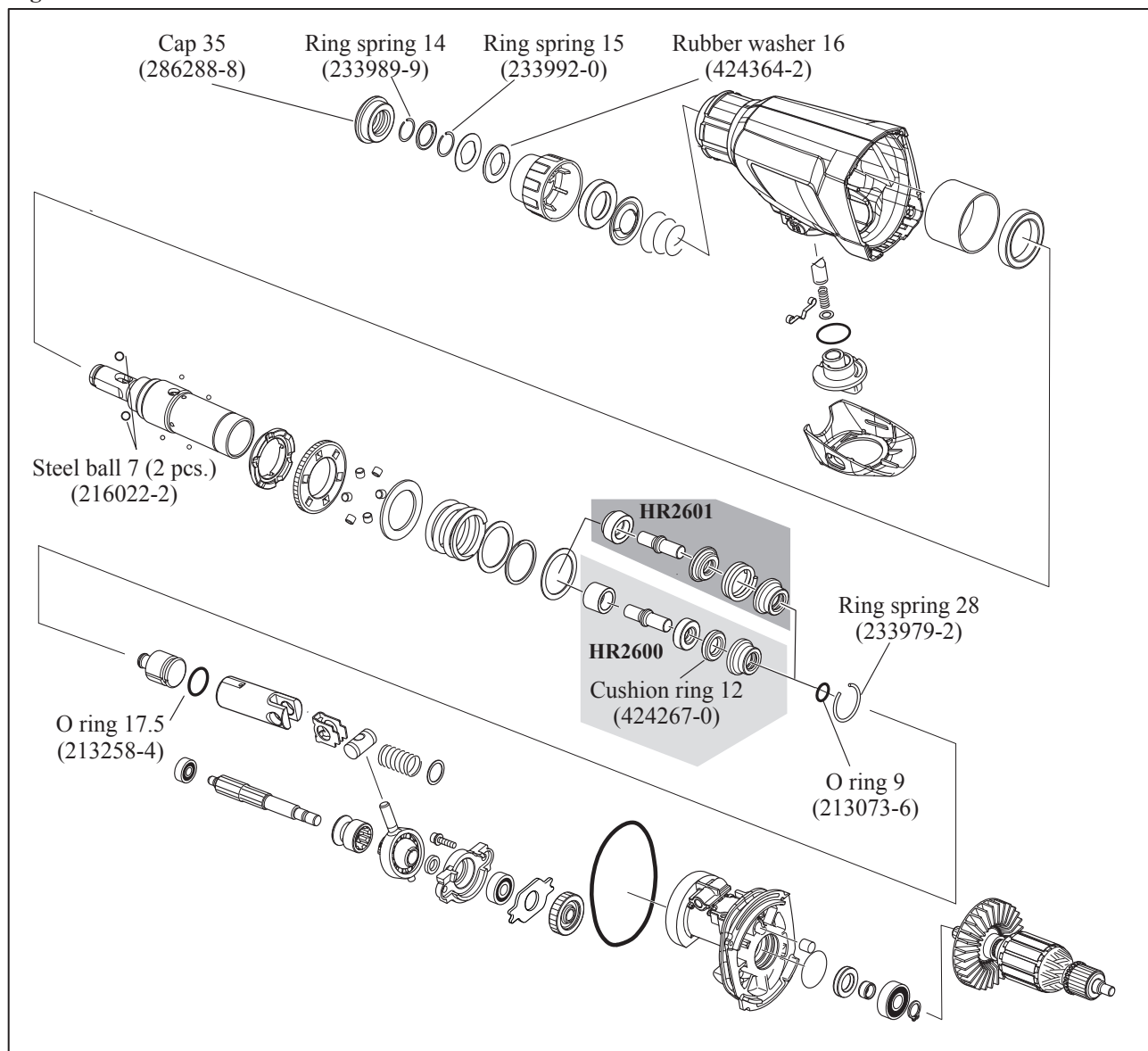

► **Circuit diagram**

Fig. D-1

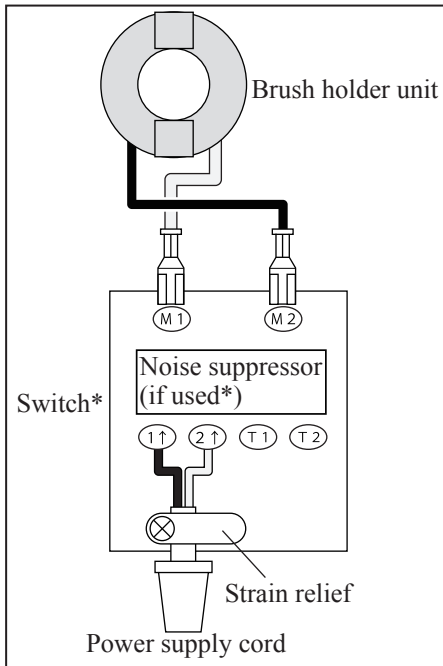

\* To comply with the electromagnetic compatibility-requirement, Switch equipped with Noise suppressor is used for some countries.

► **Wiring diagram**

Fig. D-2

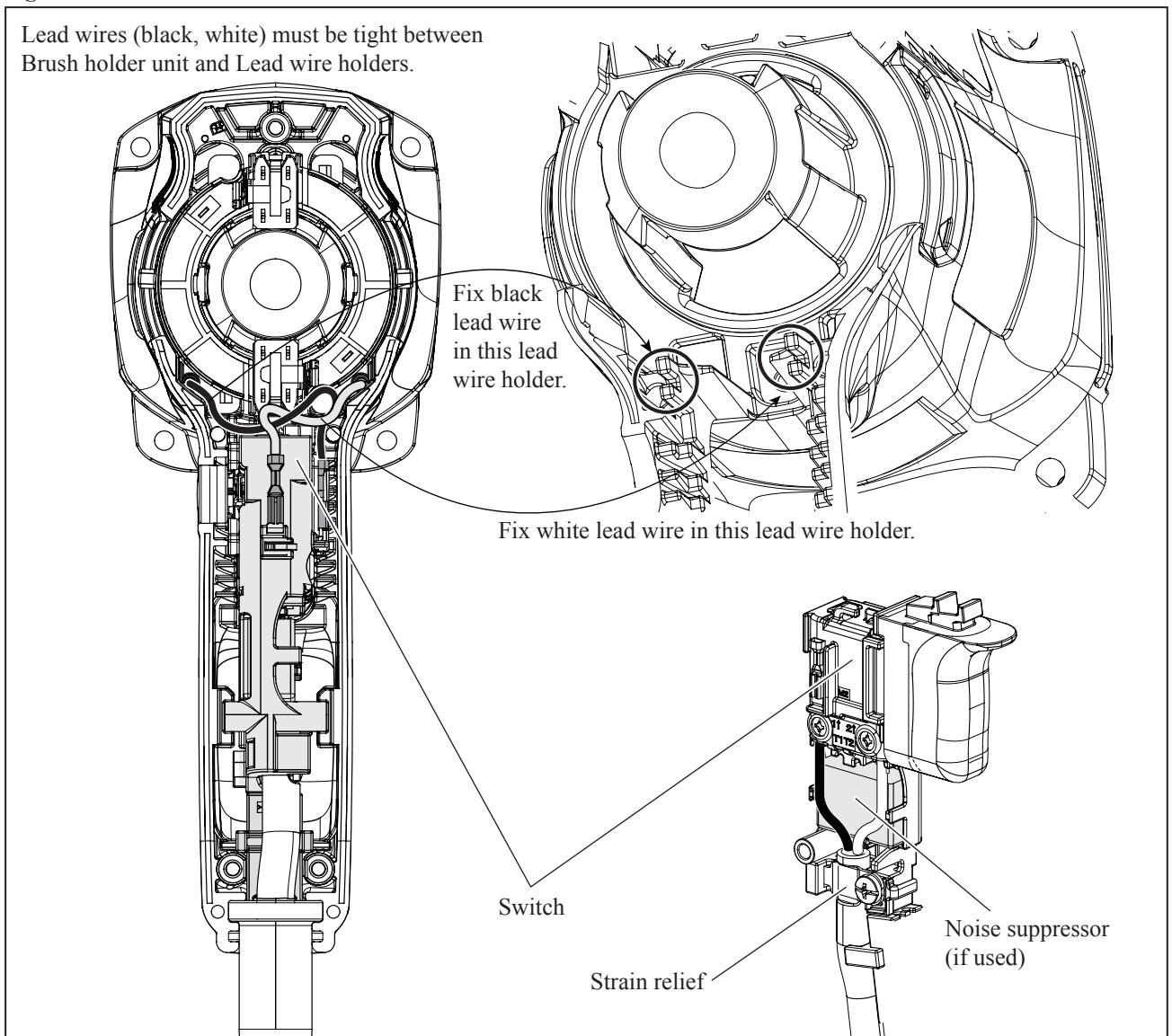

## Free Manuals Download Website

<http://myh66.com>

<http://usermanuals.us>

<http://www.somanuals.com>

<http://www.4manuals.cc>

<http://www.manual-lib.com>

<http://www.404manual.com>

<http://www.luxmanual.com>

<http://aubethermostatmanual.com>

Golf course search by state

<http://golfingnear.com>

Email search by domain

<http://emailbydomain.com>

Auto manuals search

<http://auto.somanuals.com>

TV manuals search

<http://tv.somanuals.com>