

TECHNICAL INFORMATION



PRODUCT

P 1/22

- Models No.** ▶ HR262D/BHR262, HR262TD/BHR262T (HRH01C/HRH01, HRH02C/HRH02)*1
- Description** ▶ 26mm (1") Cordless Combination Hammers
*1 Model numbers for North and Central American countries

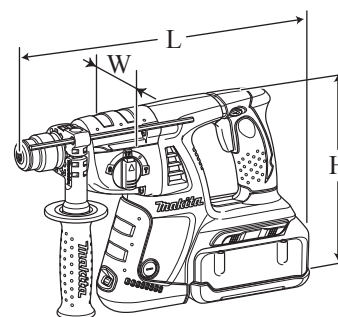

CONCEPT AND MAIN APPLICATIONS

These 36V cordless combination hammers have been developed based on Models BHR261 and BHR261T, and feature compatibility with both Makita 36V-2.6Ah Li-ion battery BL3626 and 36V-2.2Ah Li-ion battery BL3622A.

(Note: BHR261 and BHR261T run on only 36V-2.6Ah battery BL3626.)

Other features are exactly the same as BHR261 and BHR261T as follows:

- 3 operation modes (rotation only/ rotation with hammering/ hammering only)
 - Vibration absorbing handle and soft grips
 - Good tool-balance due to the center of gravity closer to handle
- HR262TD/BHR262T (HRH02/HRH02C*1) are equipped with quick change chuck.

These new products are available in the variations listed in the next page.

Dimensions: mm (")		
	HR262D/ BHR262	HR262TD/ BHR262T
Length (L)	363 (14-1/4)	387 (15-1/4)
Width (W)	104 (4-1/8)	
Height (H)	235 (9-1/4)	

Specification

		HR262D/ BHR262 (HRH01C/ HRH01)*1	HR262TD/ BHR262T (HRH02C/ HRH02)*1
Battery	Voltage: V	36	
	Capacity: Ah	2.2/ 2.6	
	Cell	Li-ion	
	Energy capacity: Wh	80/ 94	
	Charging Time: min.	60 with DC36WA/ 22 with DC36RA	
No load speed: min. ⁻¹ = rpm		0 - 1,200	
Impacts per minute= min. ⁻¹		0 - 4,800	
Max. output (W)		500	
Chuck type		Adapted for SDS-PLUS bits	Adapted for SDS-PLUS bits and Round shank bits*2
Capacity: mm (")	Concrete	26 (1)	
	Steel	13 (1/2)	
	Wood	32 (1-1/4)	
Operation mode		3 modes (Rotation only/ Rotation with hammering/ Hammering only)	
Variable speed control		Yes (by trigger)	
Reverse switch		Yes	
Torque limiter		Yes	
LED job light		Yes	
Weight according to EPTA-Procedure 01/2003*3: kg (lbs)		4.5 (9.9)	4.8 (10.6)

*2 Round shank bits can also be used by replacing the factory-mounted chuck with Quick change drill chuck (keyless).
*3 with Battery and Side grip

Standard equipment

- Grip assembly 1
- Depth gauge (Stopper pole) ... 1
- Quick change drill chuck 1
(for HR262TD/BHR262T,
HRH02/HRH02C*1)
- Bit grease 1
(for some country)
- Waste cloth 1
(for some country)

Note: The standard equipment for the tool shown above may vary by country.

Optional accessories

- SDS-PLUS bits
- Taper shank TCT bits
- Taper shank adapter
- Cotter
- Grip drill
- Grip drill holder
- Drill chuck assembly
- Chuck adapter
- Drill chuck S13
- Chuck key S13
- SDS-Plus hammer chuck set
- Scraper assembly
- Dust cup 5
- Dust cup 9
- Dust extractor attachment
- Grease vessel 30g
- Hose
- Joint 25
- Bit grease
- Plastic carrying case
- Depth gauge (Stopper pole)
- Blow out bulb
- Cold chisels
- Keyless drill chuck
- Safety goggles
- Dust cup
- Grooving chisels
- Bull points
- Scaling chisels
- Fast charger DC36RA
- Battery BL3626
- Charger DC36WA
- Battery BL3622A
- Battery adapter BAP36N
- Battery converter BCV01
- Battery converter BCV02
- Side grip set
- Grip base set

► Variation list

BHR262/ HR262D

Model No.	Charger	Battery		Battery cover	Plastic carrying case	Battery adapter	Battery converter
		Type	Quantity				
BHR262Z	No	No	No	No	No	No	No
BHR262ZC	No	No	No	No	No	No	BCV01
BHR262Z2C	No	No	No	No	No	No	BCV02
BHR262RD	DC36RA	BL3626	1	No	Yes	No	No
BHR262RDE	DC36RA	BL3626	2	1	Yes	No	No
BHR262DP1	DC36RA	BL3626	2	1	Yes	BAP36N	No
HR262DZ	No	No	No	No	No	No	No
HR262DWB	DC36WA	BL3622A	1	No	Yes	No	No
HR262DWB	DC36WA	BL3622A	2	1	Yes	No	No
HR262DBP1	DC36WA	BL3622A	2	1	Yes	BAP36N	No

BHR262T/ HR262TD

Model No.	Charger	Battery		Battery cover	Plastic carrying case	Battery adapter	Battery converter
		Type	Quantity				
BHR262TZ	No	No	No	No	No	No	No
BHR262TRDE	DC36RA	BL3626	2	1	Yes	No	No
BHR262TDP1	DC36RA	BL3626	2	1	Yes	BAP36N	No
HR262TDZ	No	No	No	No	No	No	No
HR262TDWBE	DC36WA	BL3622A	2	1	Yes	No	No

HRH01*1/ HRR01C*1, HRH02*1/ HRH02C*1

Model No.	Charger	Battery		Battery cover	Plastic carrying case	Battery adapter	Battery converter
		Type	Quantity				
HRH01Z	No	No	No	No	No	No	No
HRH01ZX2	No	No	No	No	No	No	BCV02
HRH01	DC36RA	BL3626	2	1	Yes	No	No
HRH01C	DC36WA	BL3622A	2	1	Yes	No	No
HRH02ZX2	No	No	No	No	No	No	BCV02
HRH02	DC36RA	BL3626	2	1	Yes	No	No
HRH02C	DC36WA	BL3622A	2	1	Yes	No	No

Note: All models also include the accessories listed in "Standard equipment" of page 1.

*1 Model numbers for North and Central American countries

► Repair

CAUTION: Repair the machine in accordance with “Instruction manual” or “Safety instructions”.

[1] NECESSARY REPAIRING TOOLS

Code No.	Description	Use for
1R003	Retaining ring S pliers ST-2N	Removing Ring spring 19 from Tool holder complete/ Tool holder guide complete Removing Retaining ring WR-12 from Armature shaft
1R004	Retaining ring S pliers ST-2	Removing Ring spring 29
1R022 or 1R356	Bearing plate (for arbor press)	Removing Ring spring 29
1R032	Bearing setting plate 8.2	Assembling Spiral bevel gear 26
1R033	Bearing setting plate 10.2	Assembling Spiral bevel gear 26
1R139	Drill chuck extractor	Removing Spiral bevel gear 26
1R164	Ring spring setting tool A	Assembling Oil seal 25 to Gear housing complete
1R165	Ring spring setting tool B	Assembling Needle bearing complete to Gear housing complete
1R170	T-type hex wrench 3-127	Removing two M4x25 hex socket head bolts on Inner support complete
1R212	Tip for Retaining ring pliers	Attachment of 1R003
1R232	Pipe 30	Assembling Oil seal 25 to Gear housing complete
1R249	Round bar for arbor 24-100	Removing Ring spring 28
1R252	Round bar for arbor 30-100	Removing Oil seal 25 from Gear housing complete
1R269	Bearing extractor	Removing Ball bearing 608ZZ from Inner support complete
1R281	Round bar for arbor 7-50	Removing Ring 8
1R291	Retaining ring S and R pliers	Removing Retaining Ring S-7
1R306	Ring spring removing jig	Removing Ring spring 29 from Tool holder complete/ Tool holder guide complete
318132-2	Piston cylinder	Assembling Ring spring 28 to Tool holder complete/ Tool holder guide complete

[2] LUBRICATION

Apply the following grease to protect parts and product from unusual abrasion.

* Makita grease RB No.00 to the portions indicated by black triangle

* Molybdenum disulfide lubricant to the portions indicated by gray triangle

Item No.	Description	Portion to lubricate	Lubricant	Amount
④①	O ring 16	Whole surface	Makita grease RB No.00	a little
④①	Piston cylinder	(a) Inside where Striker moves	Molybdenum disulfide	
		(b) Outside that contacts Tool holder (guide) complete		
④②	Guide plate	Inside that contacts ④③ Piston joint	Makita grease RB No.00	
④③	Piston joint	Grooves that contact ④② Guide plate		
④④	Compression spring 14	End to be fixed to the boss in Inner housing complete		
④⑧	Spur gear 10	Gear portion that engages with Spur gear 51		
④⑨	Cam shaft	(c) Gear portion that engages with ⑤① Clutch cam	Molybdenum disulfide	
		(d) Portion to be inserted into ⑤① Swash bearing 10		
		(e) Small diameter portion to be inserted into ④⑧ Spur gear 10		
⑤①	Clutch cam	(f) Groove for hooking Change plate	Makita grease RB No.00	
		(g) Gear portion that engages with ④⑨ Cam shaft		
⑤①	Swash bearing 10	(h) Pole portion to be inserted into ④③ Piston joint	Makita grease RB No.00	4g
		(i) Ball bearing portion (See Fig. 3.)		
		(j) Inside of hole		
⑤③	Spiral bevel gear 26	Gear portion that engages with Armature shaft gear		a little

Fig. 1

Transmission parts

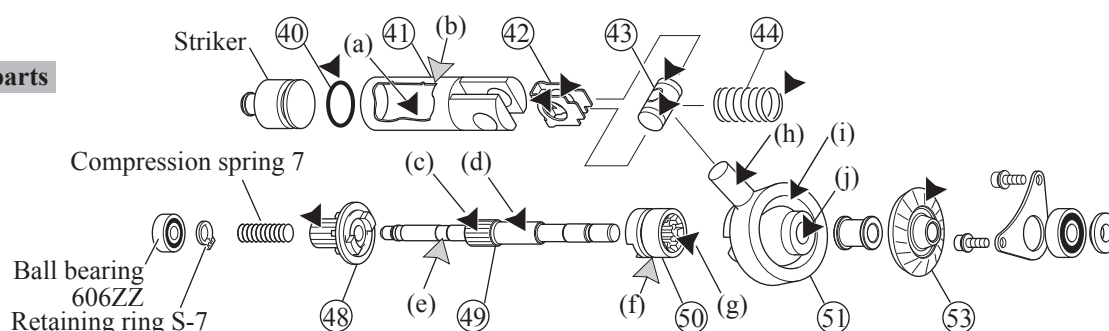

► **Repair**

[2] LUBRICATION (cont.)

Apply Makita grease RB No.00 to the following portions indicated by black triangle to protect parts and product from unusual abrasion.

Item No.		Description	Portion to lubricate
BHR262 HR262D	BHR262T HR262TD		
①	①①①	Cap 35	Lip portion where Bit is to be inserted
④		Ring 21	Inner periphery
	①①④	Stopper	Inner periphery
	①②①	Steel Ball 6 (2 pcs.)	Entire surface
	①②④	Steel Ball 5	Entire surface
⑬		Change lever	Pins
⑯		O ring 17	Entire surface
⑰		Gear housing complete	(a) Oil seal 25 on the inside of Gear housing complete
			(b) Inside where Swash bearing section rotates (See Fig. 3.)
⑲		Needle bearing complete	Needle bearing portion in Cup washer (See Fig. 37.)
⑳		Lock plate complete	Pins
㉘		Spur gear 51	(c) Gear portion
			(d) Surface where Clutch portion of ㉚ Tool holder (guide) complete contacts
㉙	①①⑤	Steel ball 7	Entire surface
㉚		Tool holder complete	Inside where Piston cylinder reciprocates
	③①	Tool holder guide complete	
㉛		Sleeve 9	Inside where Impact bolt reciprocates
㉜		Ring 10	Portion that contacts Cushion ring 13
㉞		O ring 9	Entire surface

Fig. 2

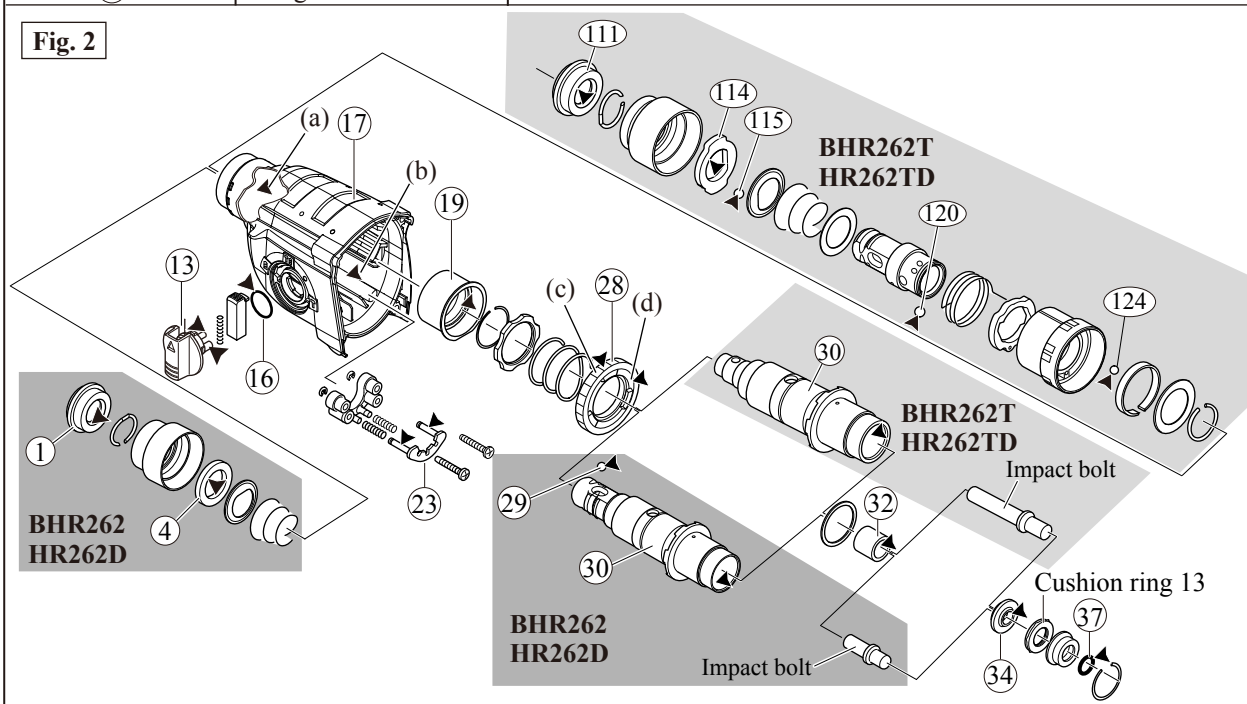
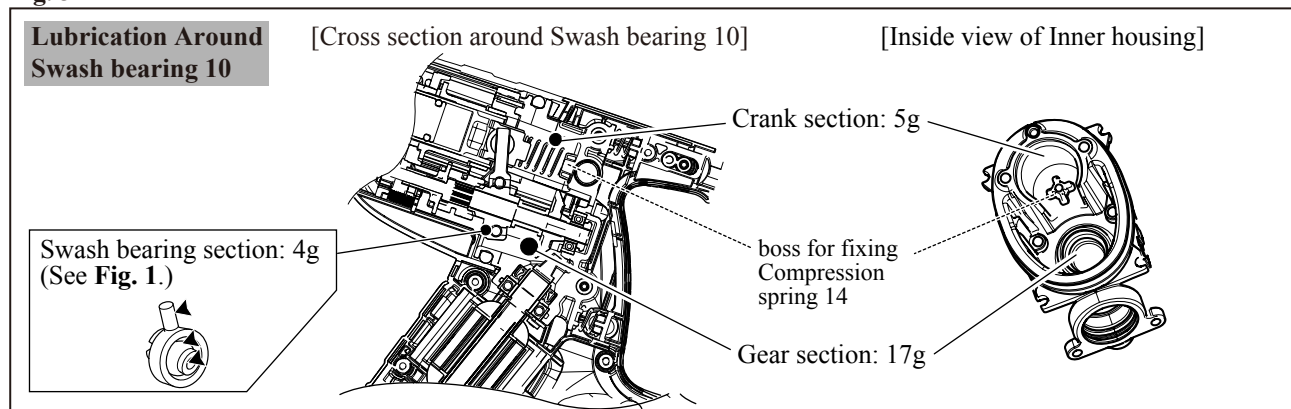

Fig. 3



► **Repair**

[3] DISASSEMBLY/ASSEMBLY

[3] -1. Bit holder section for BHR262, HR262D

Holder section for Drill chuck of BHR262T, HR262TD

DISASSEMBLING for BHR262, HR262D

Fig. 4

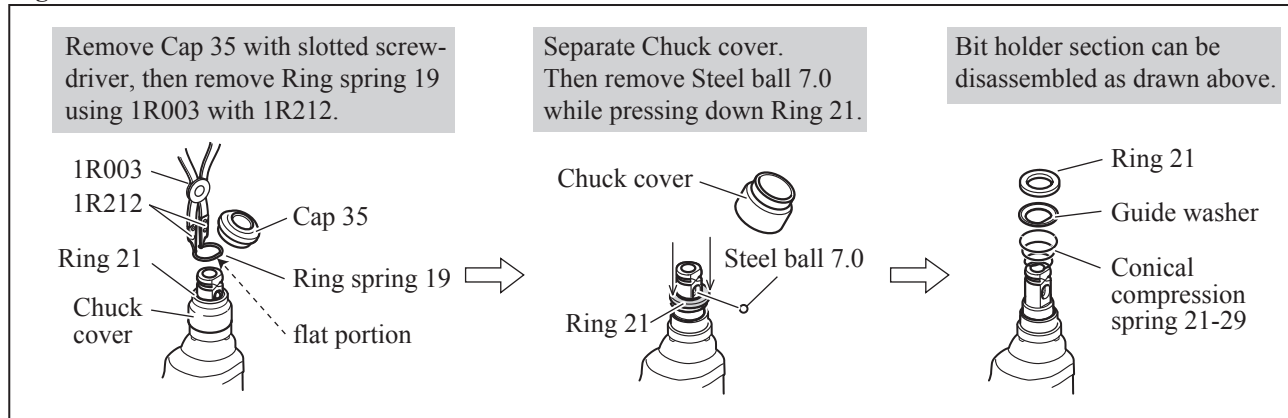

ASSEMBLING for BHR262, HR262D

Take the disassembling step in reverse.

Note: Be sure to place the flat portion of Ring spring 19 on Steel ball 7.0. (Fig. 4)

DISASSEMBLING for BHR262T, HR262TD

Fig. 5

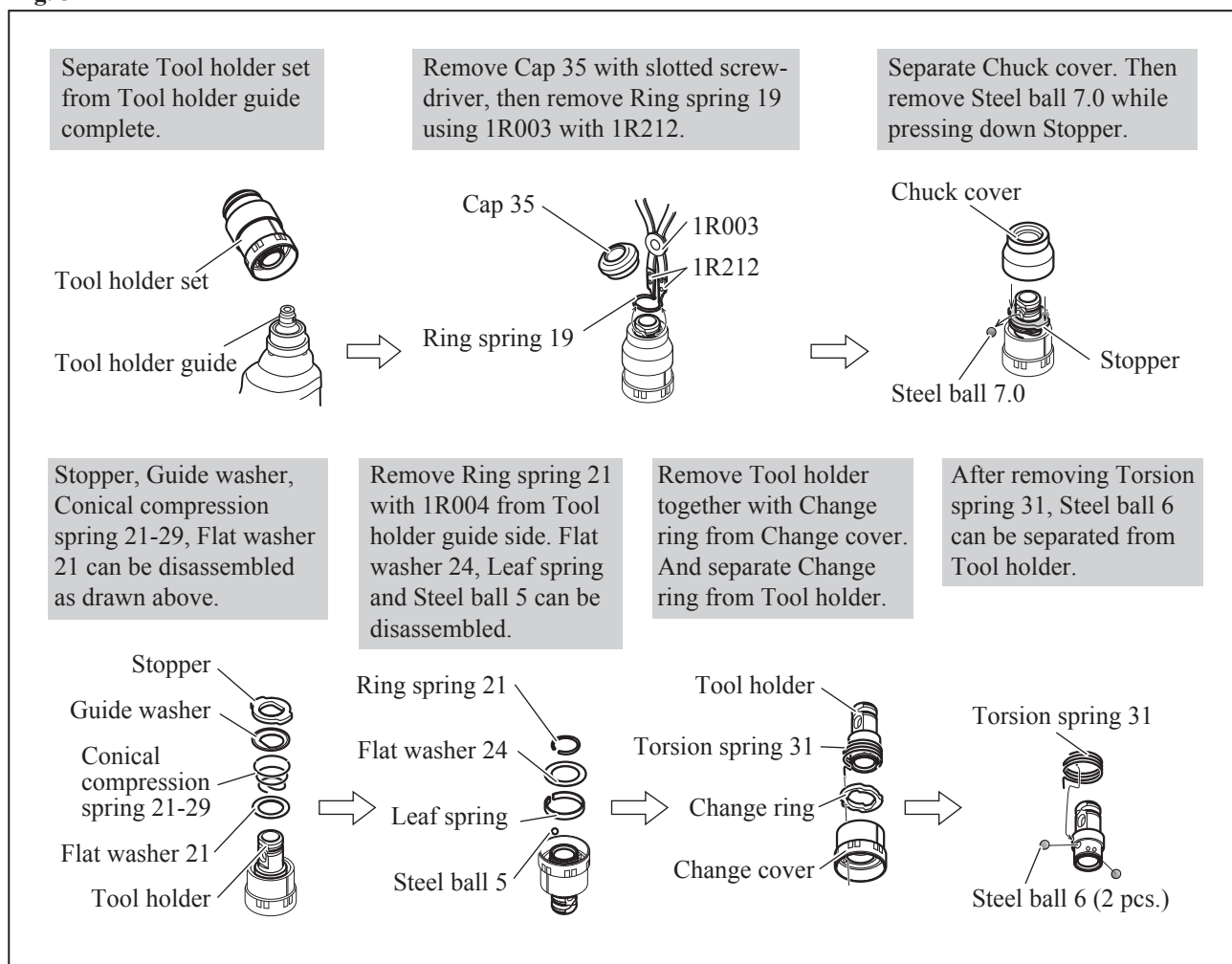

► **Repair**

[3] DISASSEMBLY/ASSEMBLY

[3] -1. Bit holder section for BHR262, HR262D

Holder section for Drill chuck of BHR262T, HR262TD (cont.)

ASSEMBLING for BHR262T, HR262TD

- (1) Assemble Change ring to Change cover. (Fig. 6)
- (2) Assemble Torsion spring 31 to Tool holder, then mount Steel balls 6 to Tool holder. (Fig. 7)

Note: Apply Makita Grease RB No.00 to Steel balls 6 to prevent them from falling off.

Fig. 6

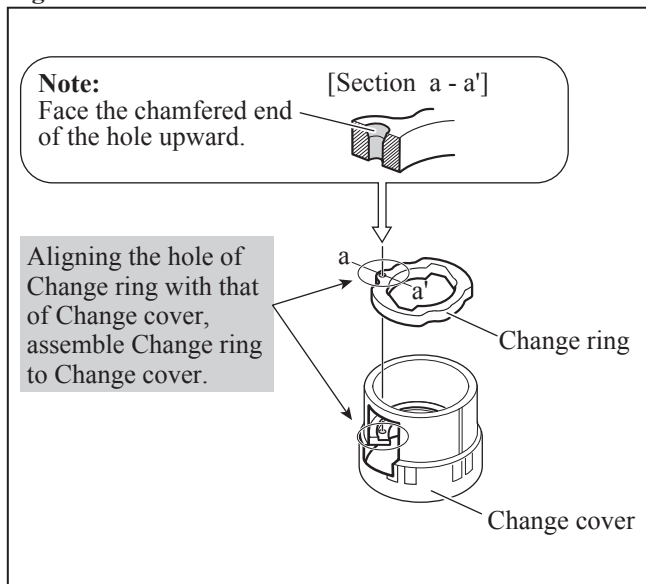
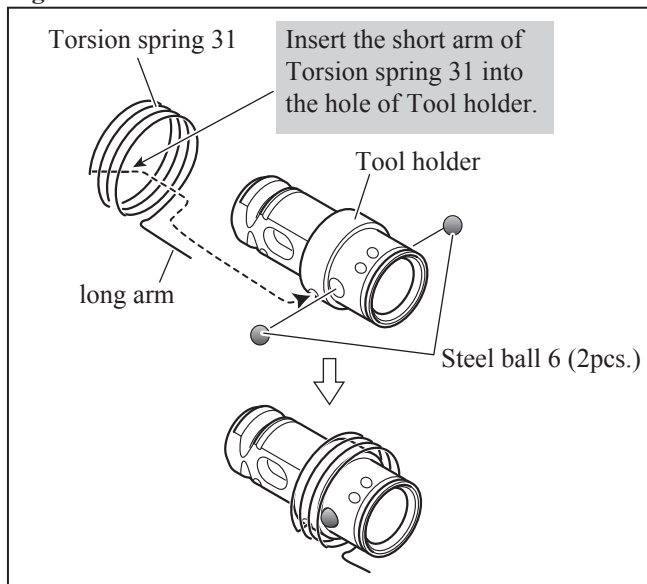
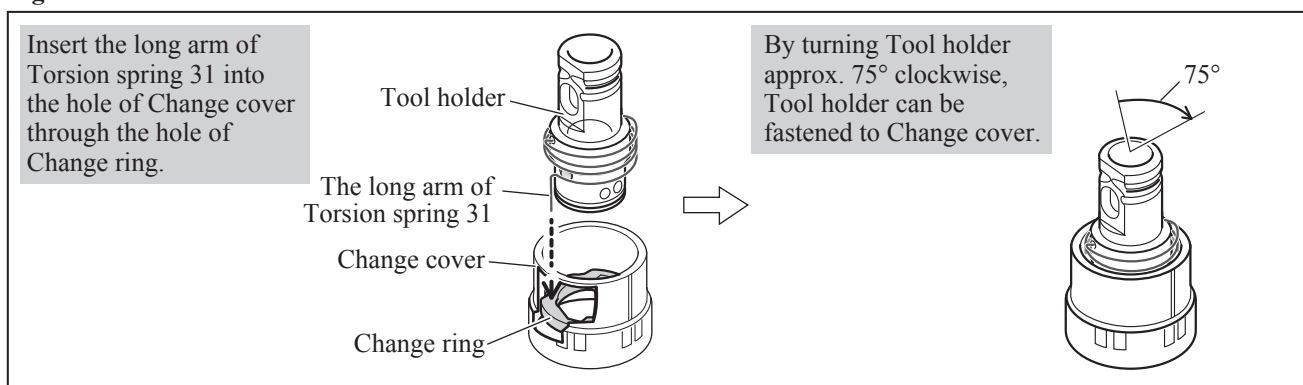

Fig. 7



- (3) Assemble Tool holder to Change cover. (Fig. 8)

Fig. 8



- (4) Put Steel ball 5.0 in the groove surrounded by Change cover and Tool holder. (left in Fig. 9)
- (5) Set Leaf spring and Flat washer 24 in change cover, then secure them with Ring spring 21. (right in Fig. 9)
- (6) As for the assembling of Cap 35 side, do the reverse of disassembling steps. Refer to Fig. 4.

Fig. 9

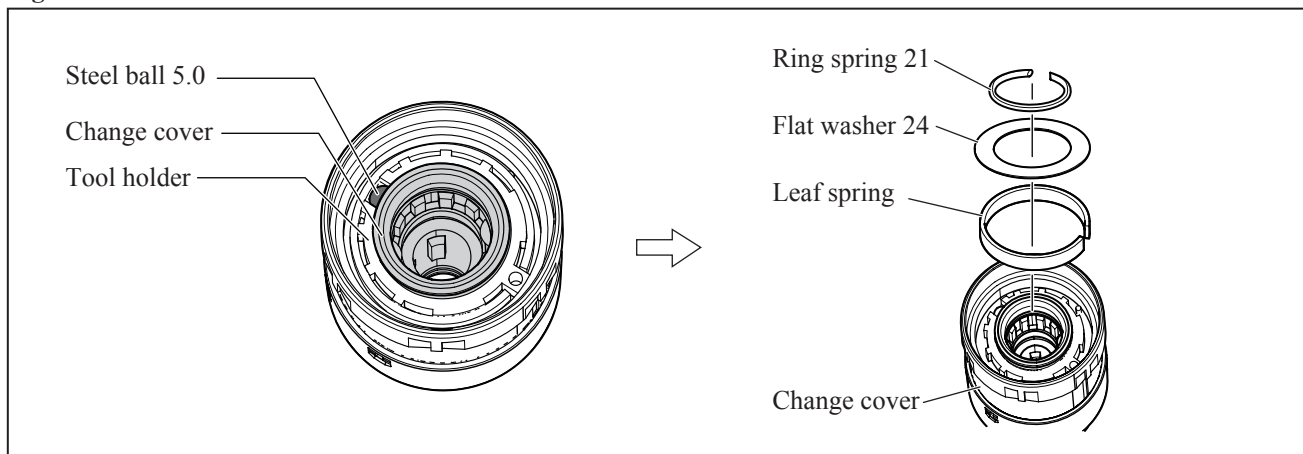

► **Repair**

[3] DISASSEMBLY/ ASSEMBLY

[3] -2. Drill chuck assembly for BHR262T, HR262TD

DISASSEMBLING

Drill chuck assembly can be disassembled as drawn in **Figs. 10 to 14**.

Fig. 10

After Removing Ring spring 21, strike Drill chuck assembly against workbench which is covered with a cloth as a cushion. Flat washer 24, Leaf spring and Steel ball 5.0 can be removed.

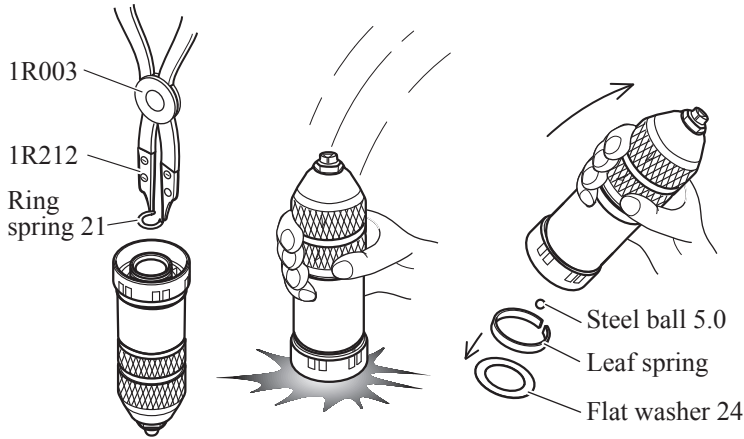

Fig. 11

Pull off Change cover. Change ring and Torsion spring 31 can be removed.

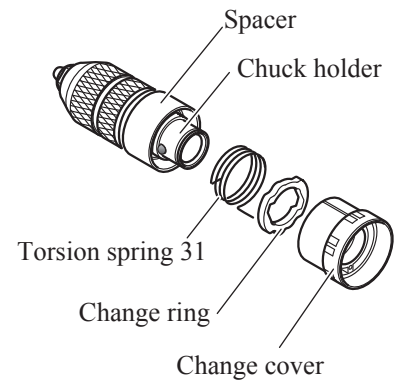

Fig. 12

Remove Spacer and two Steel balls 6 from Chuck holder.

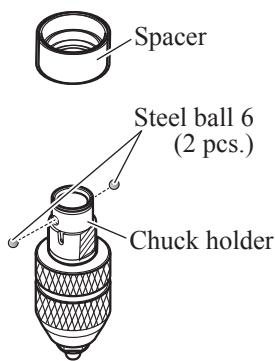

Fig. 13

Clamp the flats of Chuck holder in vise, then unscrew M6x22 Flat head screw by turning it clockwise using Impact driver.

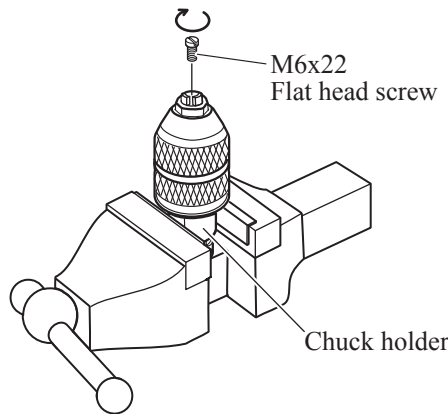
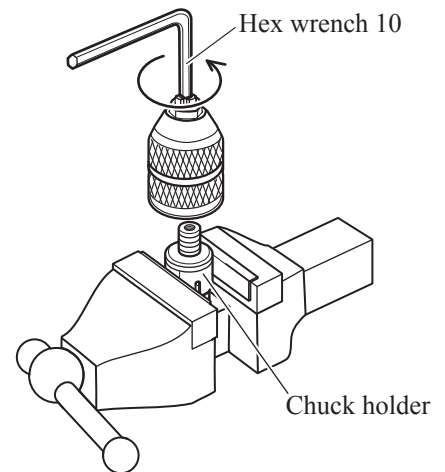

Fig. 14

Clamp the flats of Chuck holder in vise, then separate Drill chuck from Chuck holder by turning it counterclockwise using Hex wrench 10.



► Repair

[3] DISASSEMBLY/ ASSEMBLY

[3] -2. Drill chuck assembly for BHR262T, HR262TD (cont.)

ASSEMBLING

- (1) Holding Chuck holder's flat portions in vise, assemble Drill chuck to Chuck holder by turning it **clockwise** using Hex wrench 10.
- (2) Secure Drill chuck with M6x22 Flat head screw by turning it **counterclockwise** using Impact driver.
- (3) Assemble Drill chuck to Spacer. (**Fig. 15**) Then mount two Steel balls 6. (**Fig. 16**)
- (4) Mount Torsion spring 31. Then assemble Drill chuck to Change cover. (**Fig. 17**)
- (5) Mount Steel ball 5, Leaf spring and Flat washer 24 to Chuck holder, then secure them with Ring spring 21. (**Fig. 18**)

Fig. 15

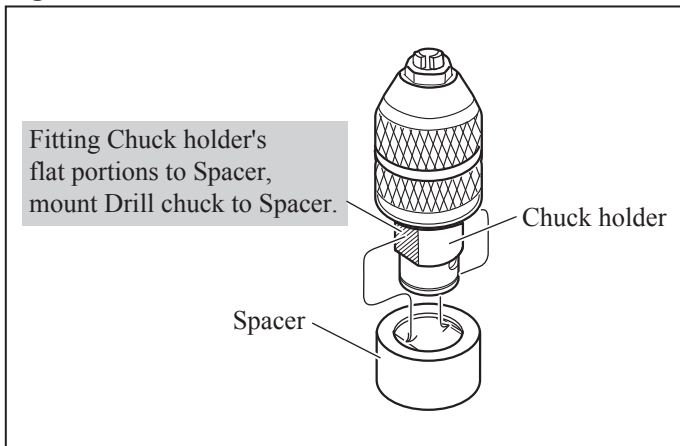

Fig. 16

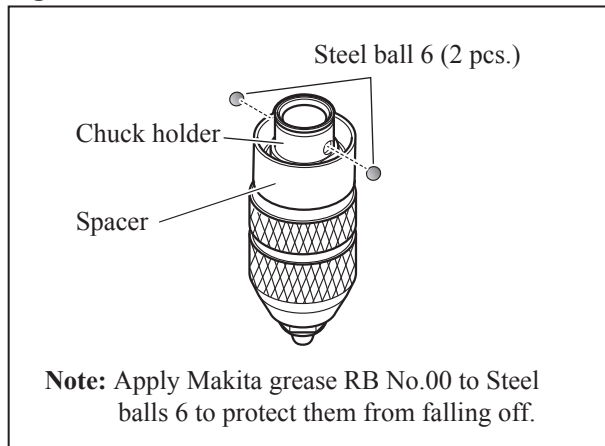

Fig. 17

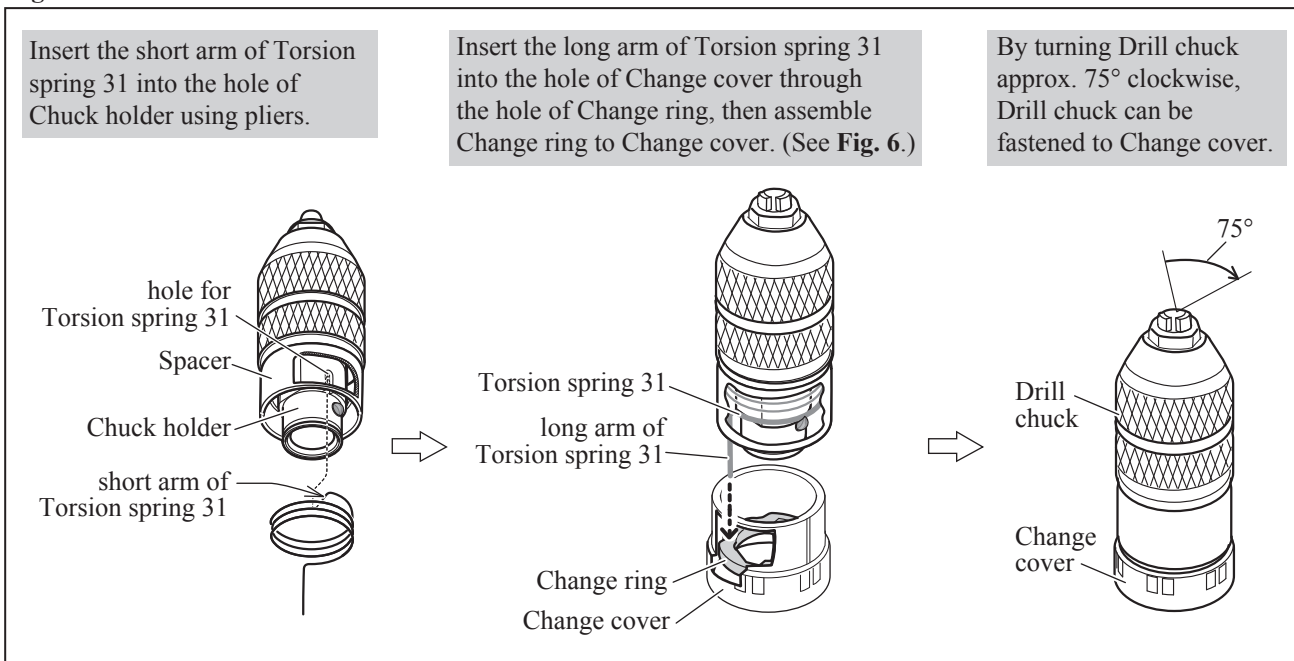
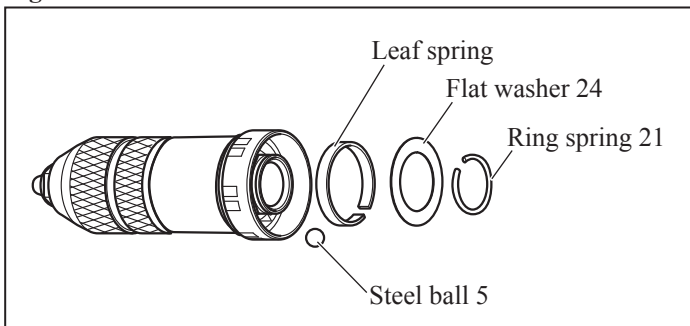

Fig. 18



► Repair

[3] DISASSEMBLY/ASSEMBLY

[3]-3. Change lever

DISASSEMBLING

Fig. 19

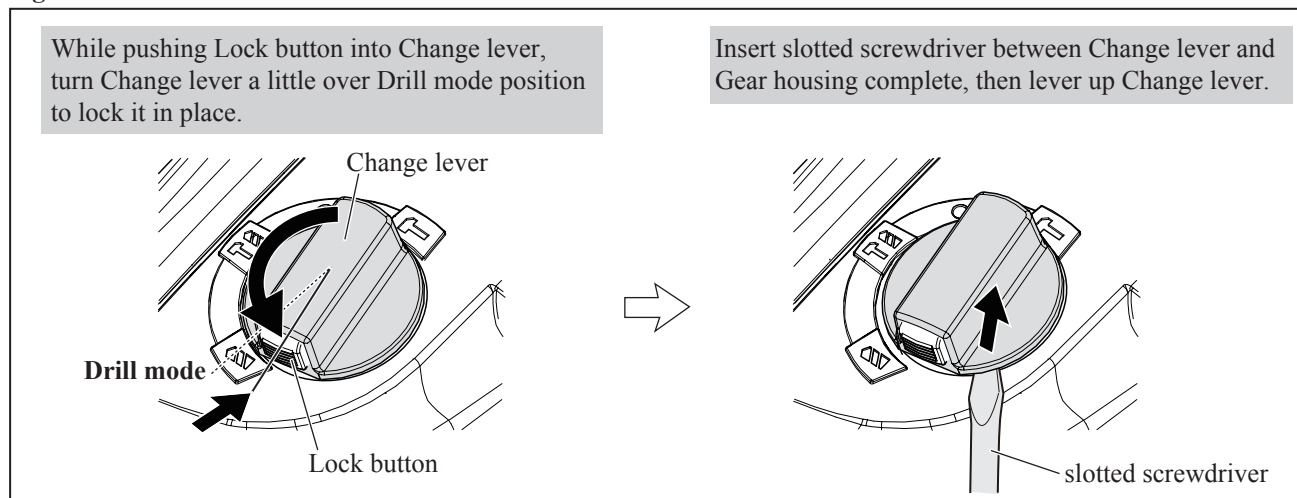

ASSEMBLING

Fig. 20

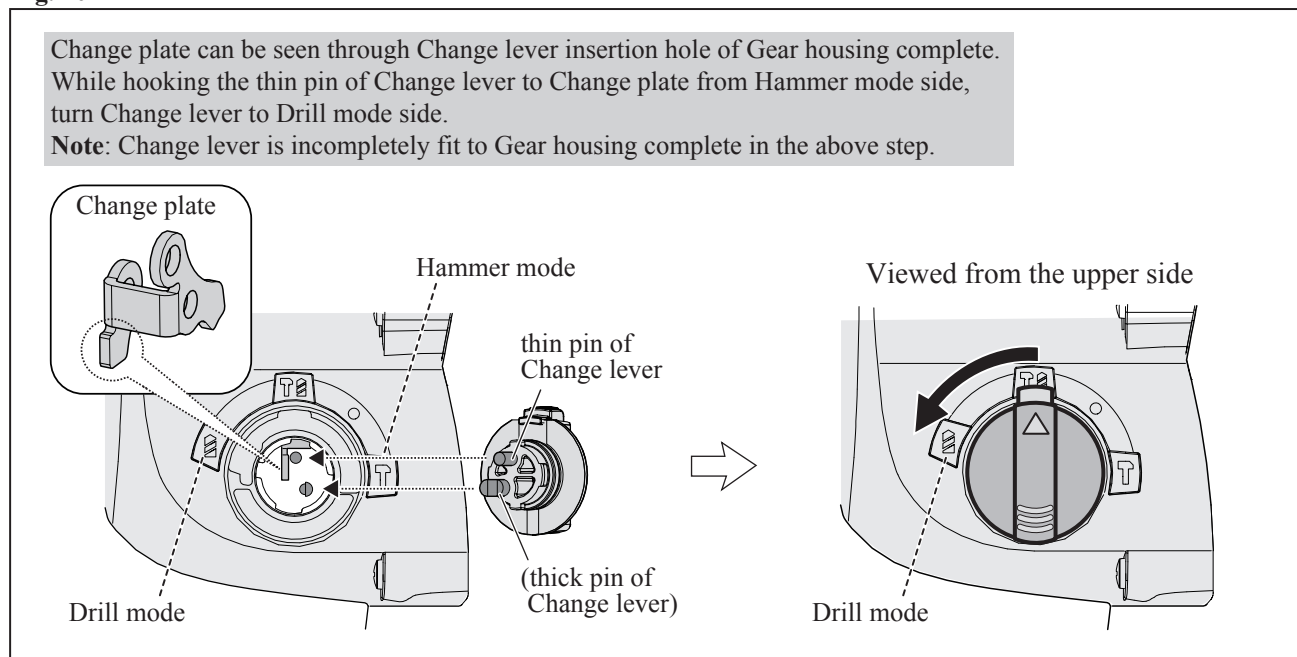
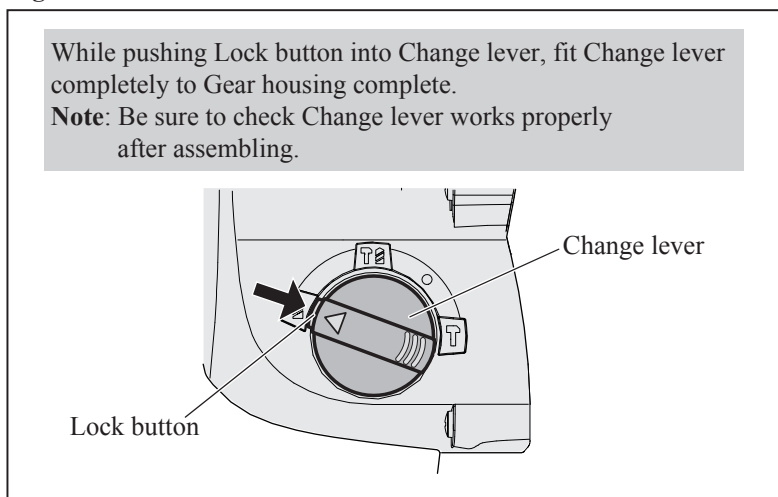

Fig. 21



► **Repair**

[3] DISASSEMBLY/ASSEMBLY

[3]-4. Motor section, Switch

DISASSEMBLING

Note: Motor section and Switch can be replaced without removing Carbon brushes.

Fig. 22

Remove four 4x35 Tapping screws from Gear housing complete and nine 4x18 Tapping screws from Housing (R). Housing (R) can now be removed.

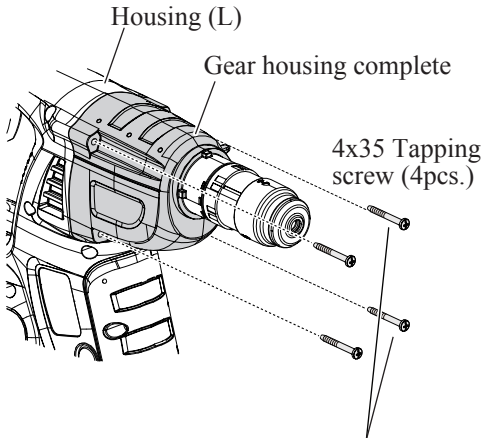

Housing (L)
Gear housing complete
4x35 Tapping screw (4pcs.)

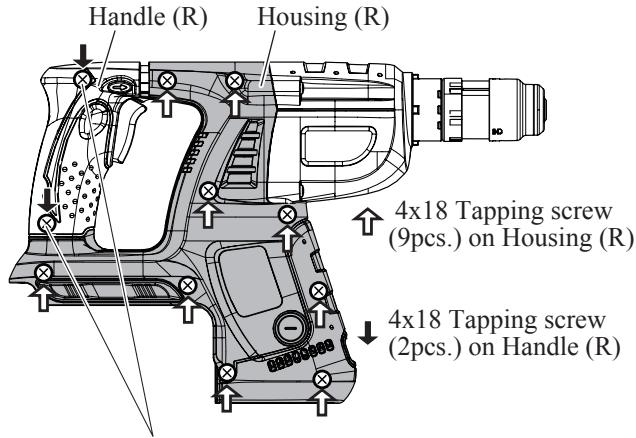

Handle (R) Housing (R)
4x18 Tapping screw (9pcs.) on Housing (R)
4x18 Tapping screw (2pcs.) on Handle (R)

Note:
For easier repair, except when repairing Motor section, it is recommended not to remove two 4x35 Tapping screws that fasten Housing (L) to Gear housing complete. (See Fig. 23.)

Note:
Except when replacing Switch, it is recommended not to remove two 4x18 Tapping screws that fasten Handle (R) to Handle (L). (See Fig. 24.) With the screws left untightened, Handle section can be removed as an assembly. (See Fig. 25.)

Fig. 23

When removing four 4x35 Tapping screws from Gear housing complete and nine 4x18 Tapping screws from Housing (R), put the loop portion of Side grip between workbench and Housing (L) as drawn on the right for efficient disassembly. Without the support of Side grip, Gear housing complete will tend to separate from Housing (L), causing the machine to fall apart.

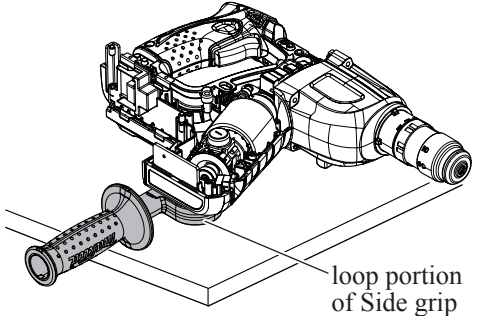

loop portion of Side grip

Fig. 24

Remove two Pins 6 and two 4x18 Tapping screws, then separate Handle (R) from Handle (L). Switch can now be replaced. (Also see Figs. D-1 and D-2.)

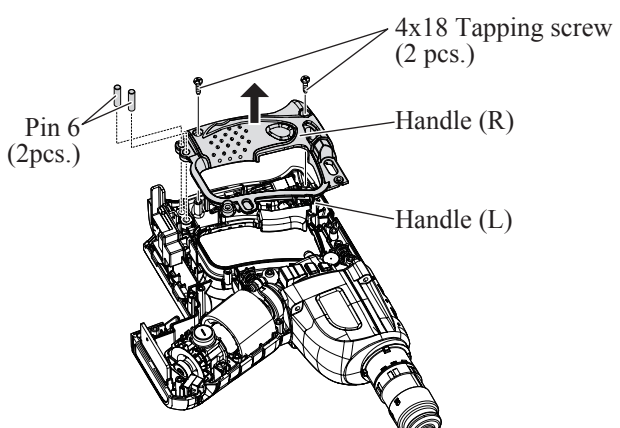

4x18 Tapping screw (2 pcs.)
Pin 6 (2pcs.)
Handle (R)
Handle (L)

Fig. 25

Remove two Pins 6 and Handle section from Housing (L) to disassemble Motor section.

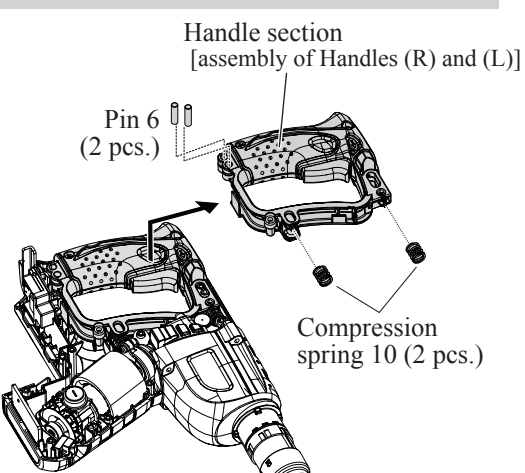

Handle section [assembly of Handles (R) and (L)]
Pin 6 (2 pcs.)
Compression spring 10 (2 pcs.)

► Repair

[3] DISASSEMBLY/ASSEMBLY [3]-4. Motor section, Switch (cont.)

DISASSEMBLING

Fig. 26

Remove Brush holder on the right side by unscrewing two 4x18 Tapping screws. Motor section and Gear section can now be removed as an assembly.

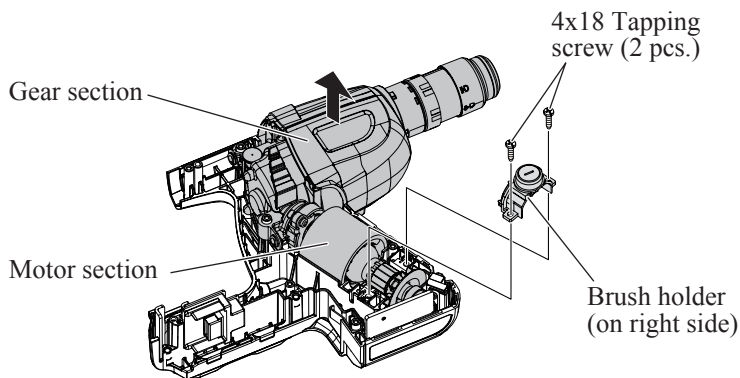

Fig. 27

- ① Remove two M4x12 Hex socket head bolts with 1R170.
- ② Remove Bearing retainer A.
- ③ Pull out Armature from Inner housing complete.

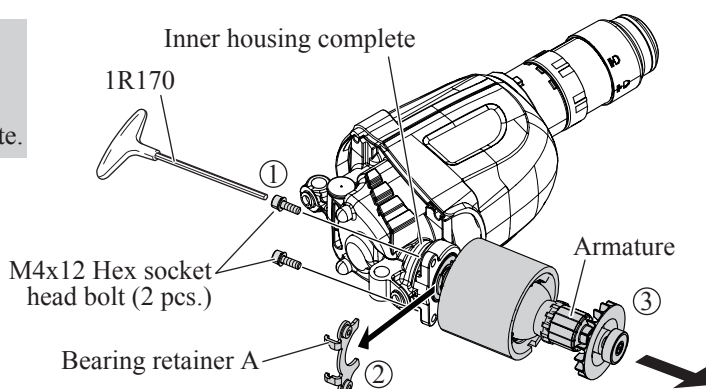
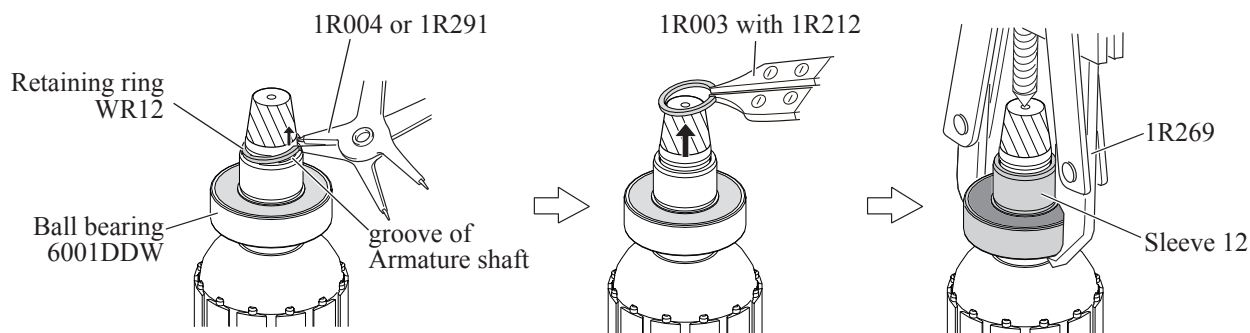

Fig. 28

When removing Ball bearing 6001DDW, remove Retaining ring WR12 from Armature shaft in advance. Then remove Ball bearing 6001DDW together with Sleeve 12 using 1R269.

Note: Retaining ring WR12 is firmly seated in the groove of Armature shaft, and the groove is so small that the ring cannot be removed with a pair of commercial retaining ring pliers only.

Therefore, slip the gap of the ring outside of the groove using 1R004 or 1R291, then remove the ring using commercial retaining ring pliers or 1R003 with 1R212.



► Repair

[3] DISASSEMBLY/ASSEMBLY

[3]-4. Motor section, Switch (cont.)

ASSEMBLING

Fig. 29

When inserting Armature into Inner housing complete, do not fail to pass Armature through Yoke unit in advance.

Note: Yoke unit is not directional when assembled with Armature.

Without enough care, Ball bearing 6001DDW on the drive-end of Armature may often be incompletely seated in the bearing room of Inner housing complete. Therefore, fit Ball bearing 6001DDW completely into the bearing room in Inner housing complete while carefully turning Armature by hand to engage the gear of Armature shaft with Spiral bevel gear 26 in Inner housing complete. Then fix Ball bearing 6001DDW with Bearing retainer and two M4x12 Hex socket head bolts.

Note: Be sure to apply adhesive (ThreeBond 1321B/1342 or Loctite 242) to the threads when reusing M4x12 Hex socket head bolts removed from the machine because they are threadlocking bolts.

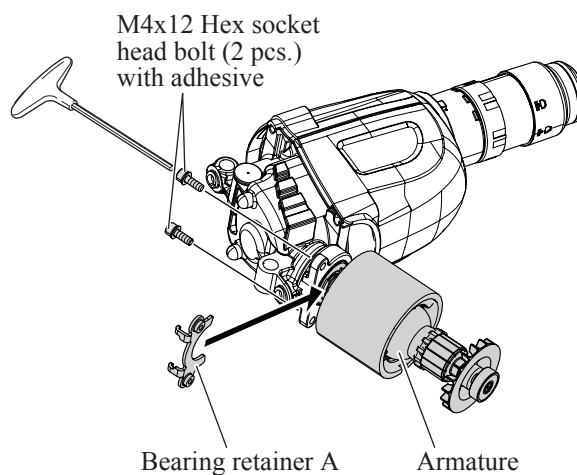
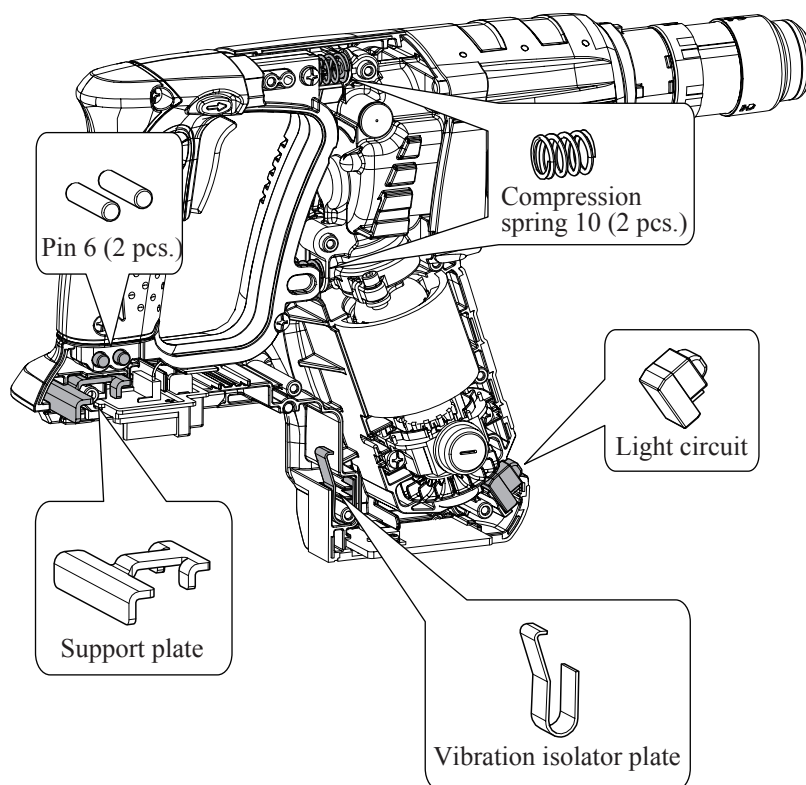

Fig. 30

Make sure that the five parts shown below are set in place before mounting Housing R to Housing L.



► Repair

[3] DISASSEMBLY/ASSEMBLY

[3]-5. Tool holder section for BHR262, HR262D/

Tool holder guide section for BHR262T, HR262DT

DISASSEMBLING

Note: Tool holder (guide) section can be removed without disassembling Housing section.

- (1) Remove Chuck section as drawn in **Figs. 4 and 5**.
- (2) Remove Change lever as drawn in **Fig. 19**.
- (3) Remove four 4x35 Tapping screws as drawn in **Fig. 22**.
- (4) Take steps drawn in **Figs. 31 and 32**.

Fig. 31

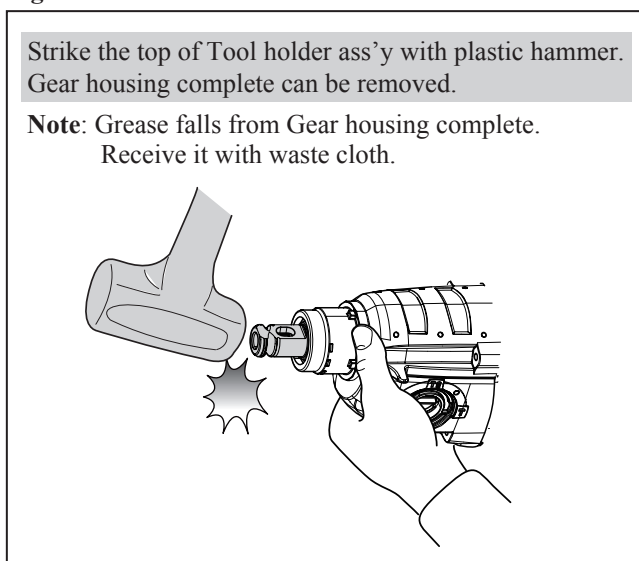

Fig. 32

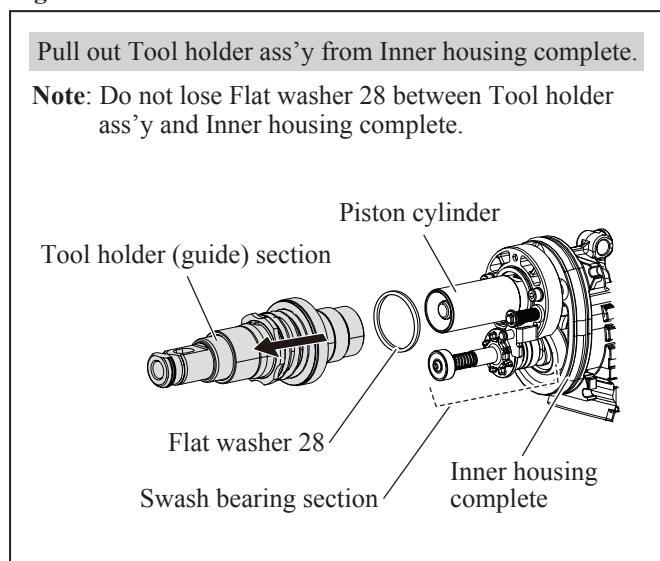
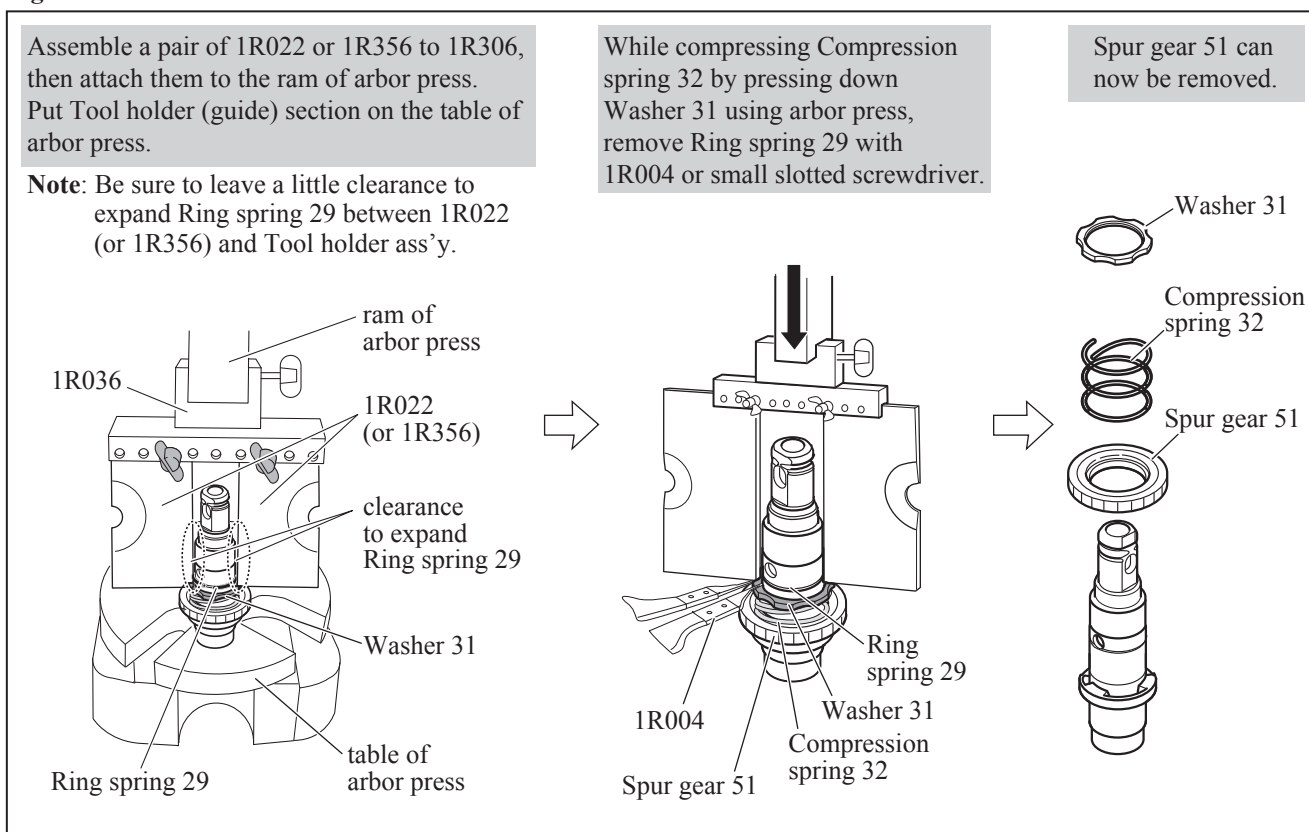

Fig. 33



ASSEMBLING

Take the disassembling step in reverse.

► Repair

[3] DISASSEMBLY/ASSEMBLY

[3]-6. Needle bearing complete and Oil seal 25

DISASSEMBLING

Fig. 34

Put Gear housing complete on arbor press table, and keep it upright. Then, by pressing down Oil seal 25 using 1R252, Oil seal 25 and Needle bearing complete can be removed from Gear housing complete with gentle pressure.

Note:

On arbor press table, Gear housing complete can stand almost upright on its end edges. Although the end edges are rather thin, you need not worry about breakage because Oil seal 25 and Needle bearing complete are fitted to Gear housing complete with low press fit force.

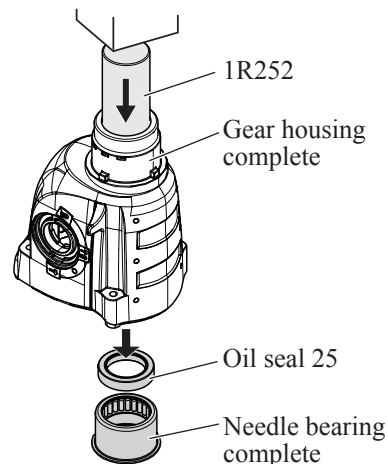

ASSEMBLING

- 1) Assemble Oil seal 25 to Gear housing complete. (Figs. 35, 36)
- 2) Assemble Needle bearing complete. (Fig. 37)

Fig. 35

With 1R232 and arbor press, insert Oil seal 25 until it stops. In this step, Oil seal 25 is not yet inserted completely because the outer diameter of 1R232 is larger than that of Oil seal setting hole.

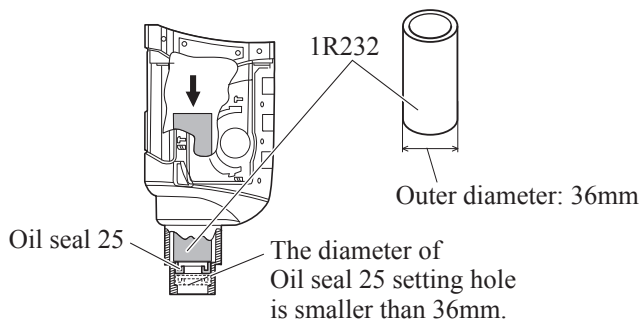

Fig. 36

Using arbor press and the 34mm outer diameter end of 1R164, press down Oil seal 25 until it stops at its original position.

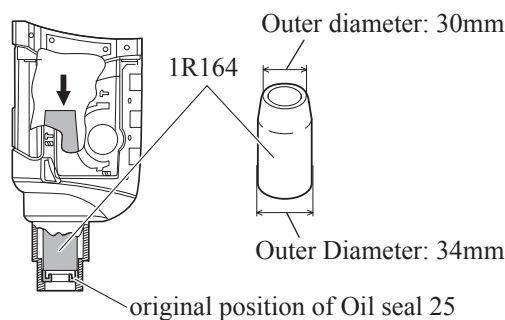
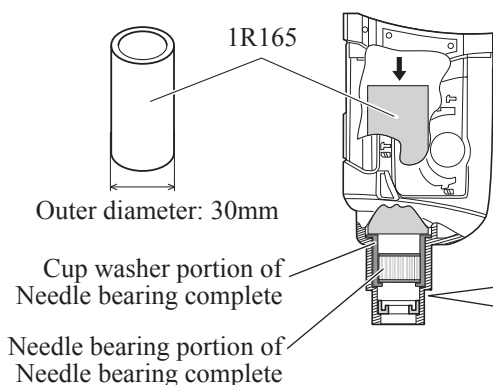

Fig. 37

With 1R165 and arbor press, press down Needle bearing complete until it stops.



Note:

- 1) Do not use 1R164 in this step.
- 2) Do not press **Needle bearing portion** directly.
- 3) Too much pressure will deform Needle bearing complete. Do not press hard.
- 4) Be sure to press **Cup washer portion** with gentle pressure.

bottom side of Gear housing complete

Needle bearing complete, viewed from rear side

Face the flat portion of Needle bearing complete towards the bottom side of Gear housing complete.

► **Repair**

[3] DISASSEMBLY/ASSEMBLY

**[3]-7. Impact bolt in Tool holder complete for BHR262, HR262D)/
Tool holder guide complete for BHR262T, HR262TD**

DISASSEMBLING

- (1) When Striker is left in Tool holder (guide) complete, push Striker out of Tool holder (guide) complete by inserting 1R281 from the top end then by striking 1R281 with plastic hammer.
- (2) Remove Tool holder (guide) section as instructed in [3]-5.
- (3) Remove Ring spring 28 from Tool holder (guide) complete and disassemble Impact bolt section. (Figs. 38 to 41)

Fig. 38

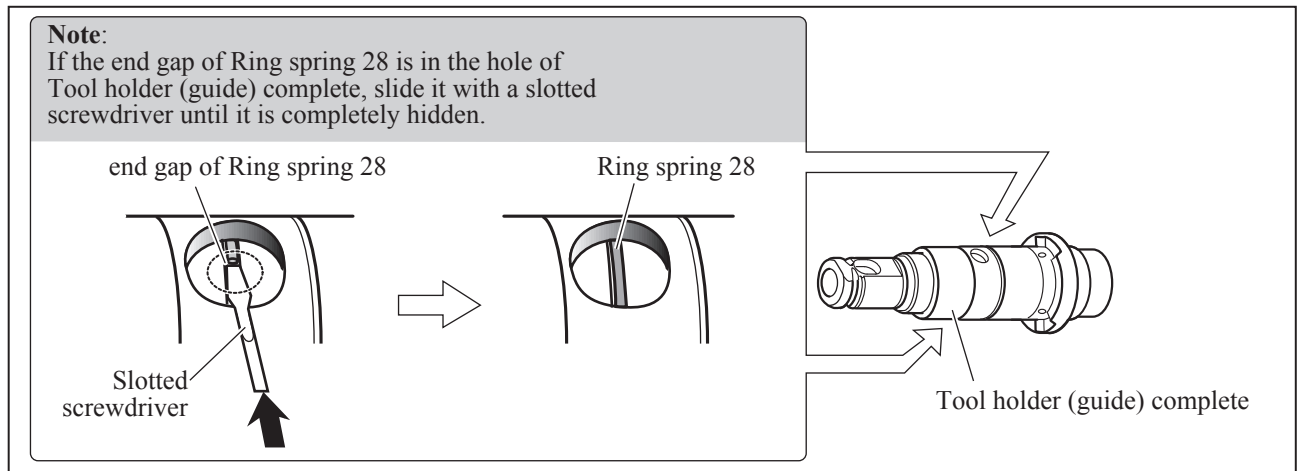

Fig. 39

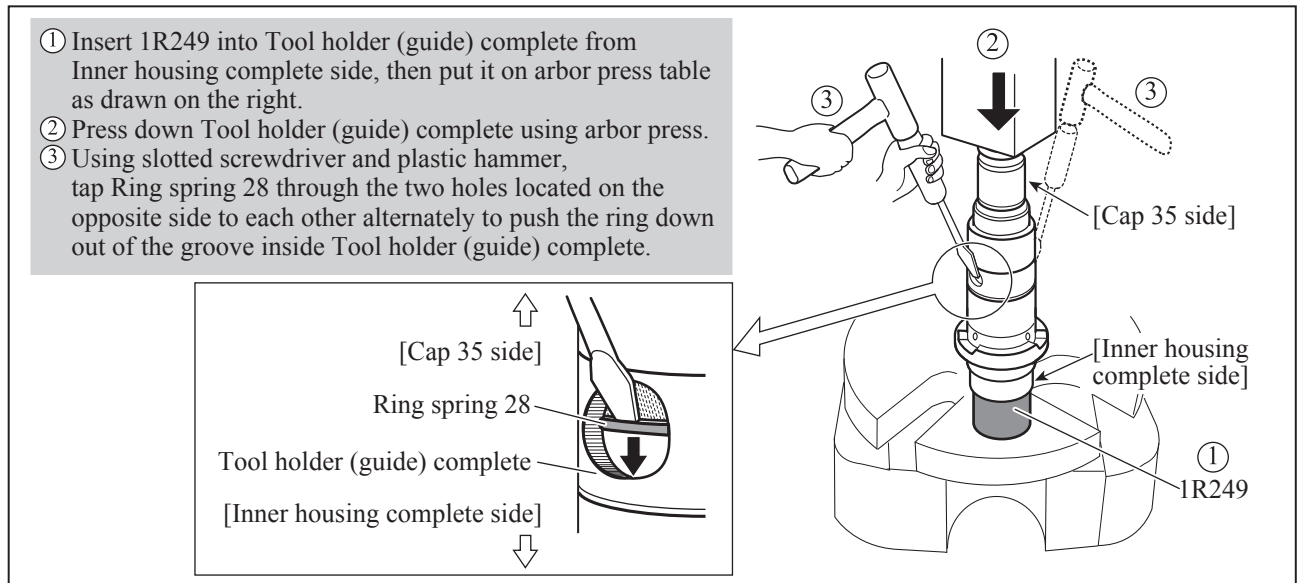

Fig. 40

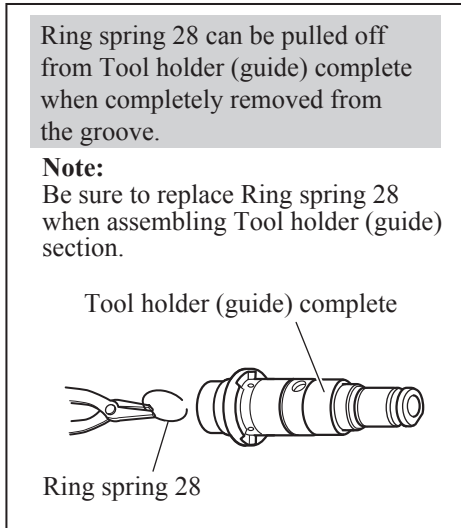
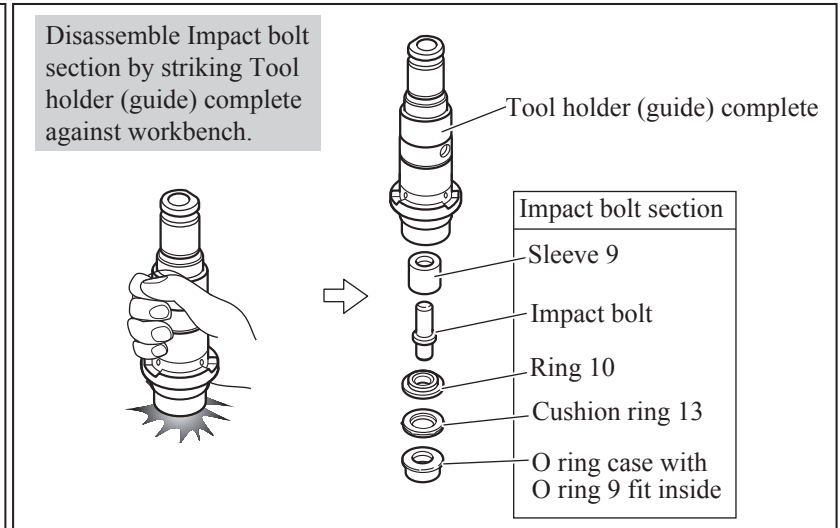

Fig. 41



► **Repair**

[3] DISASSEMBLY/ASSEMBLY

**[3]-7. Impact bolt in Tool holder complete for BHR262, HR262D)/
Tool holder guide complete for BHR262T, HR262TD (cont.)**

ASSEMBLING

1) Assemble Impact bolt section to Tool holder (guide) complete as drawn in **Fig. 42**.

Fig. 42

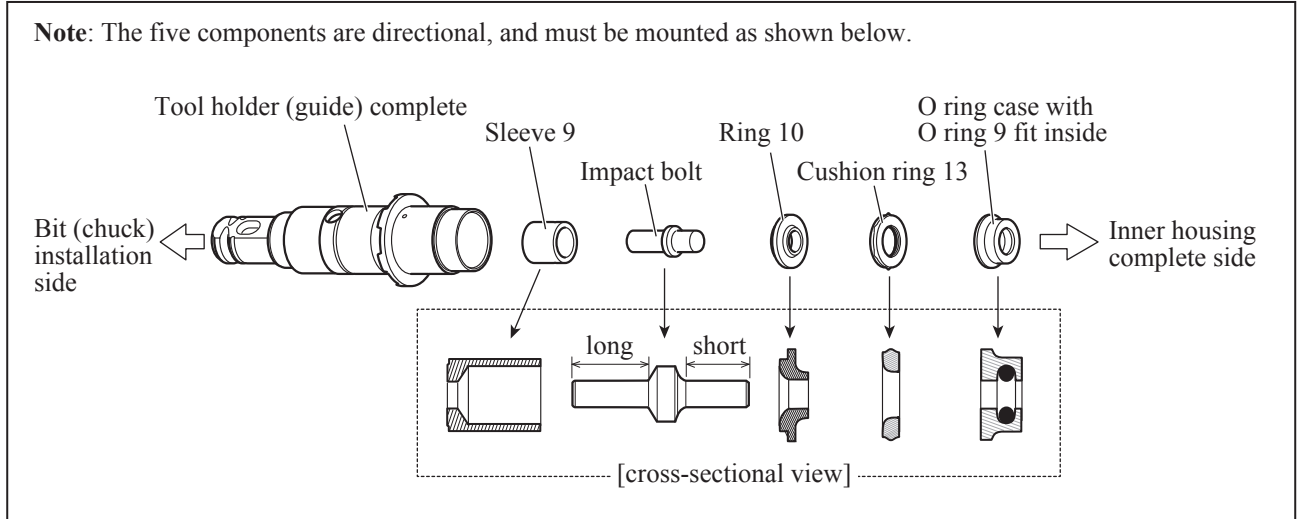

2) Push Ring spring 28 into the inner groove of Tool holder (guide) complete as drawn in **Fig. 43**.

Fig. 43

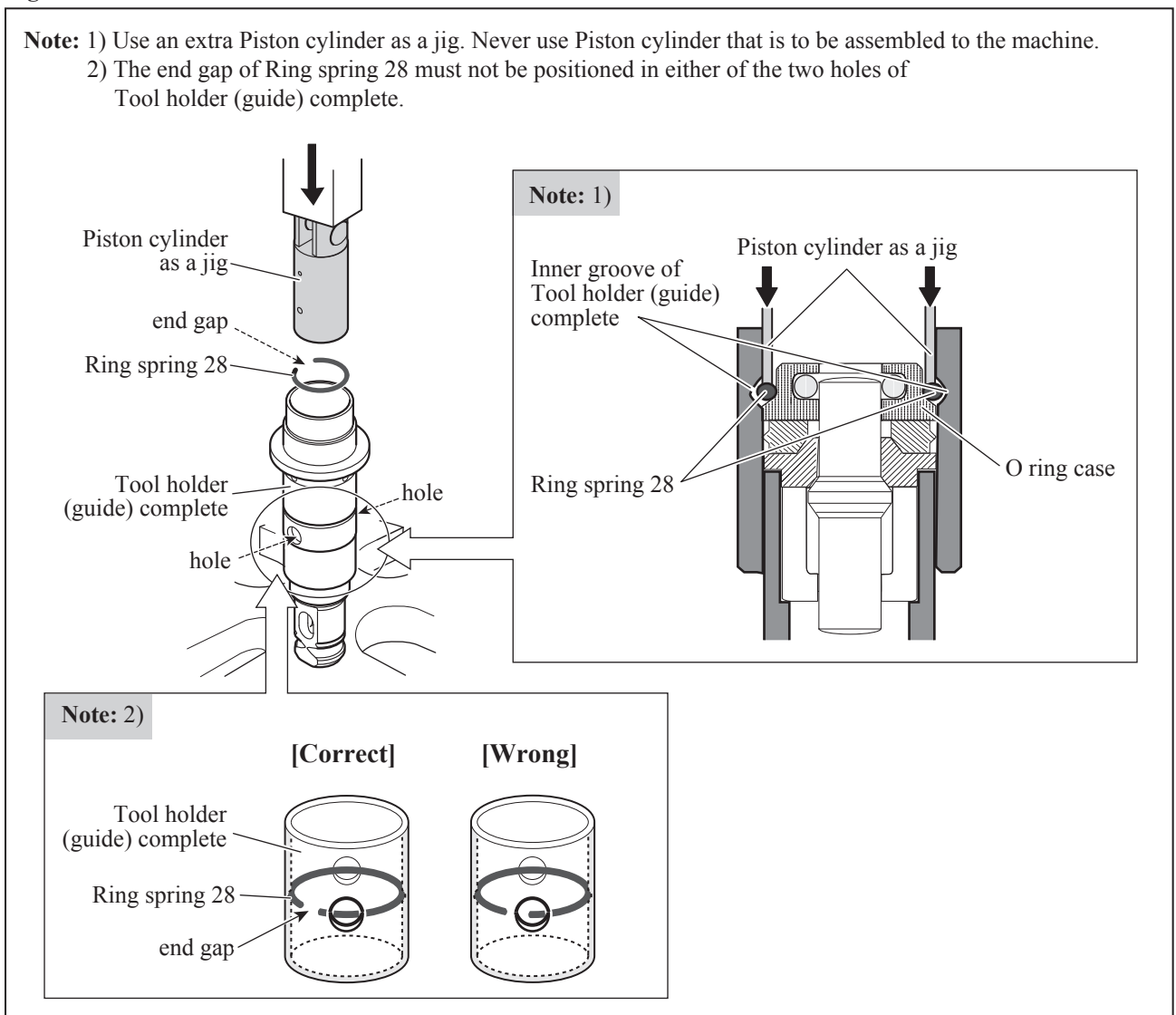

► **Repair**

[3] DISASSEMBLY/ASSEMBLY

[3]-8. Swash bearing 10, Gear section

DISASSEMBLING

Note: This step can be done without removing Motor section.

- 1) Remove Gear housing complete as instructed in [3]-5.
- 2) Remove Inner support complete by loosening two M4x25 Hex socket head bolts using 1R170. (**Fig. 44**)
- 3) Remove two M4x12 Hex socket head bolts that is seated on Bearing retainer B on Inner support complete. (**Fig. 45**)
- 4) Remove Swash bearing 10 portion and Piston cylinder portion from Inner housing complete. (**Fig. 46**)
- 5) When Ball bearing 606ZZ is left in Gear housing complete after removing Swash bearing section, insert Cam shaft into the hole of Ball bearing 606ZZ and tilt Cam shaft back and forth (**Fig. 47**), then tap Gear housing complete with plastic hammer as drawn in **Fig. 48**. Ball bearing 606ZZ can now be removed.
- 6) Put Spiral bevel gear 26 on a U-groove of 1R139 as shown in **Fig. 49**, then press down Cam shaft using 1R281 to loosen the press fit of Cam shaft to Spiral bevel gear 26, Ball bearing 608ZZ and Ring 8 at a time. (**Fig. 49**) Also Clutch cam, Swash bearing 10, Sleeve 9 and Bearing retainer B can be removed from Cam shaft in this step. (**Fig. 50**)
- 7) By removing Retaining ring S-7 from Cam shaft using 1R291, Compression spring 7 and Spur gear 10 can be removed from Cam shaft. (**Fig. 50**)

Fig. 44

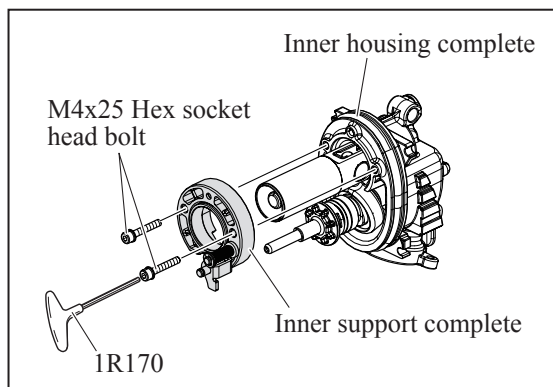

Fig. 45

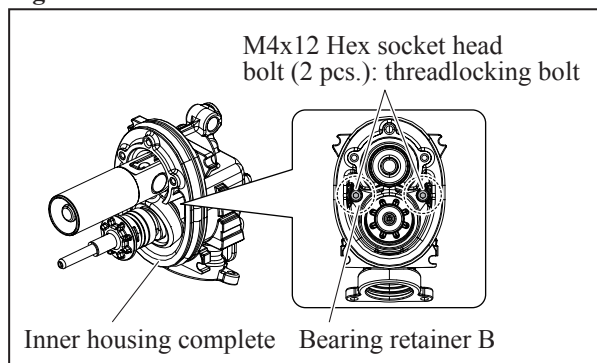

Fig. 46

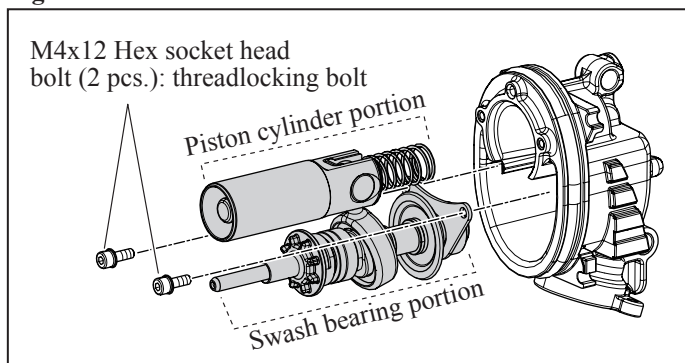

Fig. 47

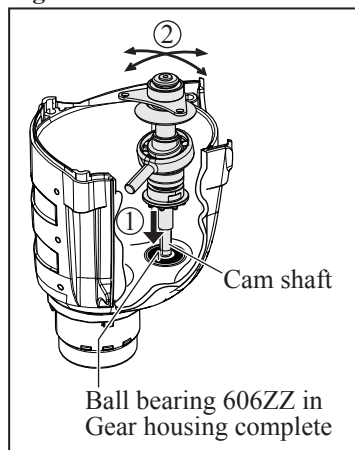

Fig. 48

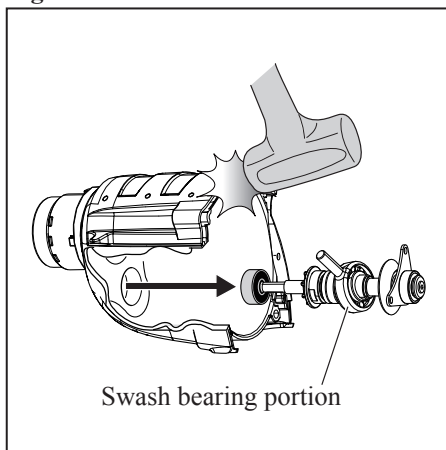

Fig. 49

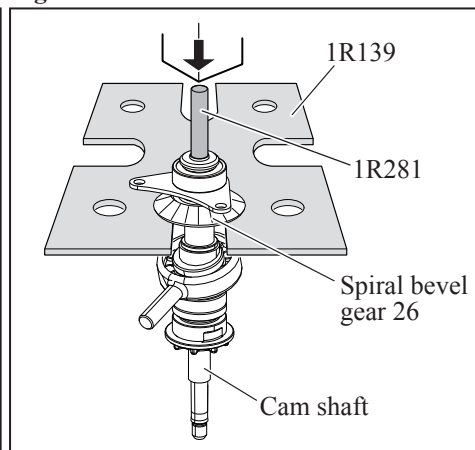
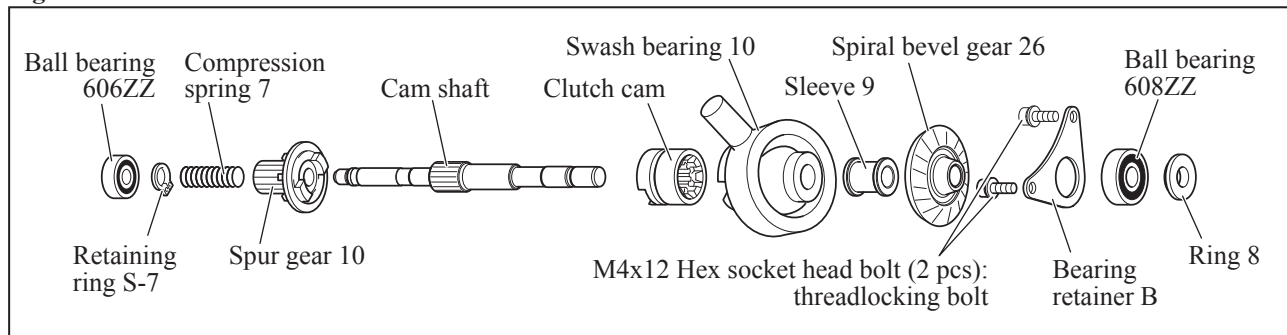

Fig. 50



► **Repair**

[3] DISASSEMBLY/ASSEMBLY

[3]-8. Swash bearing 10, Gear section (cont.)

ASSEMBLING

Note: Be sure to apply Makita grease RB No.00 and Molybdenum disulfide lubricant to the specific portions shown in **Figs. 1, 2 and 3.**

- 1) Onto Cam shaft, slide Swash bearing 10, Sleeve 9, Spiral bevel gear 26 in order, then press-fit them using 1R032, 1R033 and arbor press.
- 2) Slide Bearing retainer B onto Cam shaft in advance, then press-fit Ball bearing 608ZZ then Ring 8 onto the shaft; be careful not to fix Bearing retainer B between the bearing and Spiral bevel gear 26.
- 3) Onto Cam shaft, slide Super gear 10 and Compression spring 7 in order, then secure them with Retaining ring S-7 using 1R291.
- 4) Mount Guide plate then Piston joint to Piston cylinder. (**Fig. 51**)
- 5) Fit Compression spring 14 over the boss of Inner housing complete. (**Figs. 3 and 52**)
- 6) Insert the pole of Swash bearing 10 through the hole of Piston joint, then mount Swash bearing portion into Inner housing complete. Secure Swash bearing portion by fixing Bearing retainer B to Inner housing complete with two M4x12 Hex socket head bolts. (**Fig. 53**)
Note: Be sure to apply adhesive to the threads of the two M4x12 Hex socket head bolts.
- 7) Insert Change plate into the groove of Clutch cam, then secure Inner support complete with two M4x25 Hex socket head bolts. (**Fig. 54**)

Fig. 51

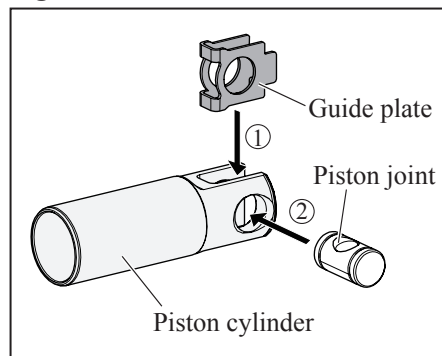

Fig. 52

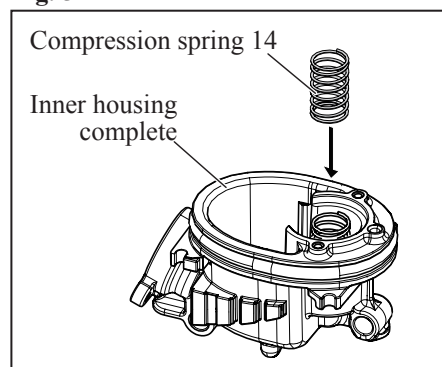

Fig. 53

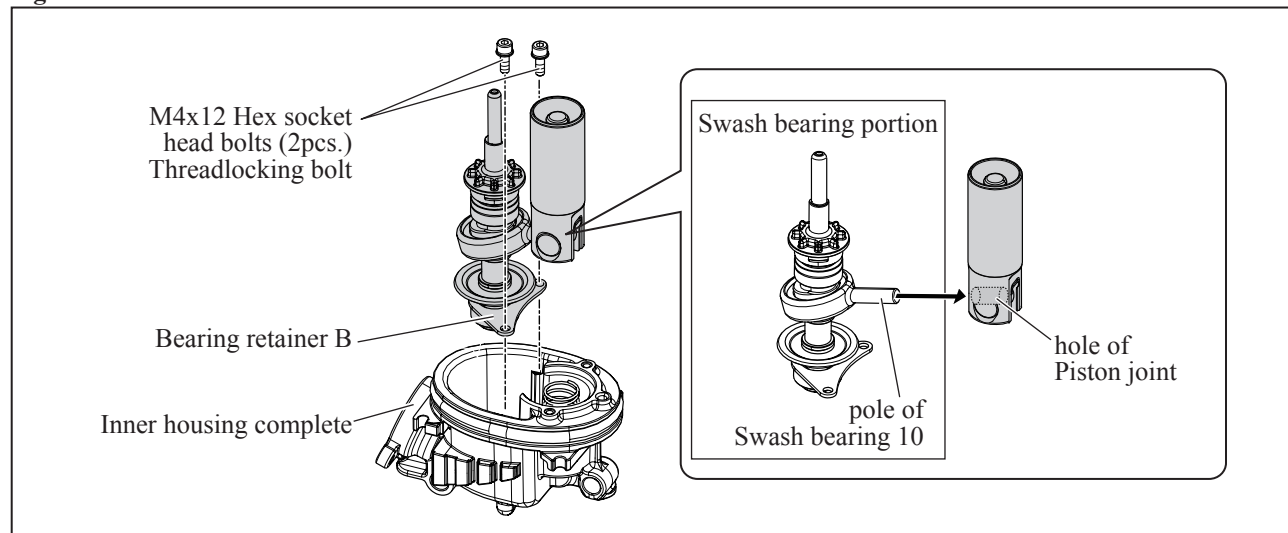
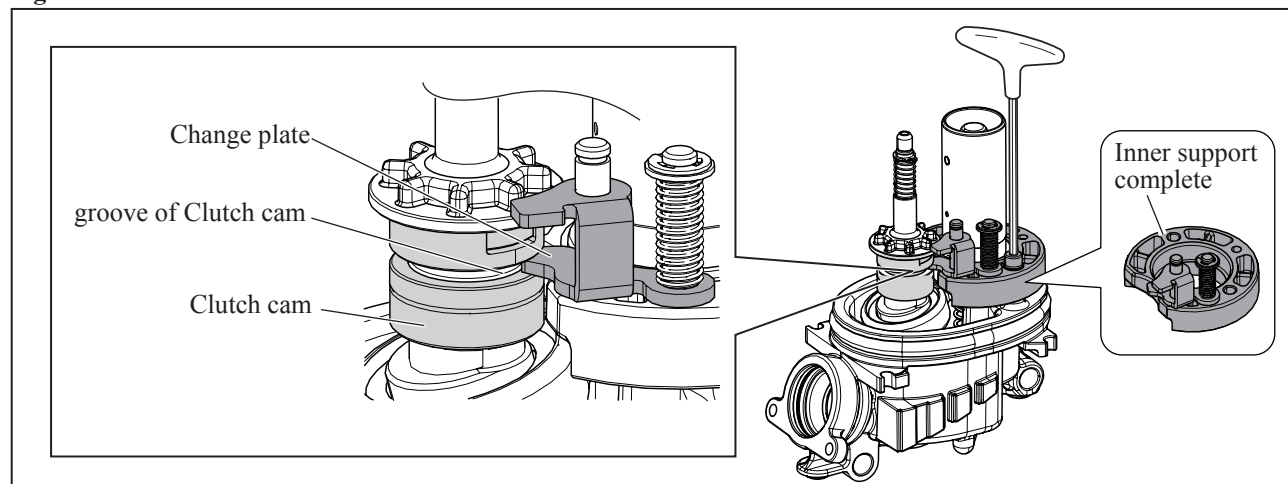

Fig. 54



► **Repair**

[4] Maintenance program

It is recommended to replace the following parts at the same time when replacing Carbon brushes. (**Fig. 55**)

Note: Be sure to put Makita grease RB No. 00 and Molybdenum disulfide lubricant to the specific portions.

Refer to **Figs. 1, 2 and 3.**

Fig. 55

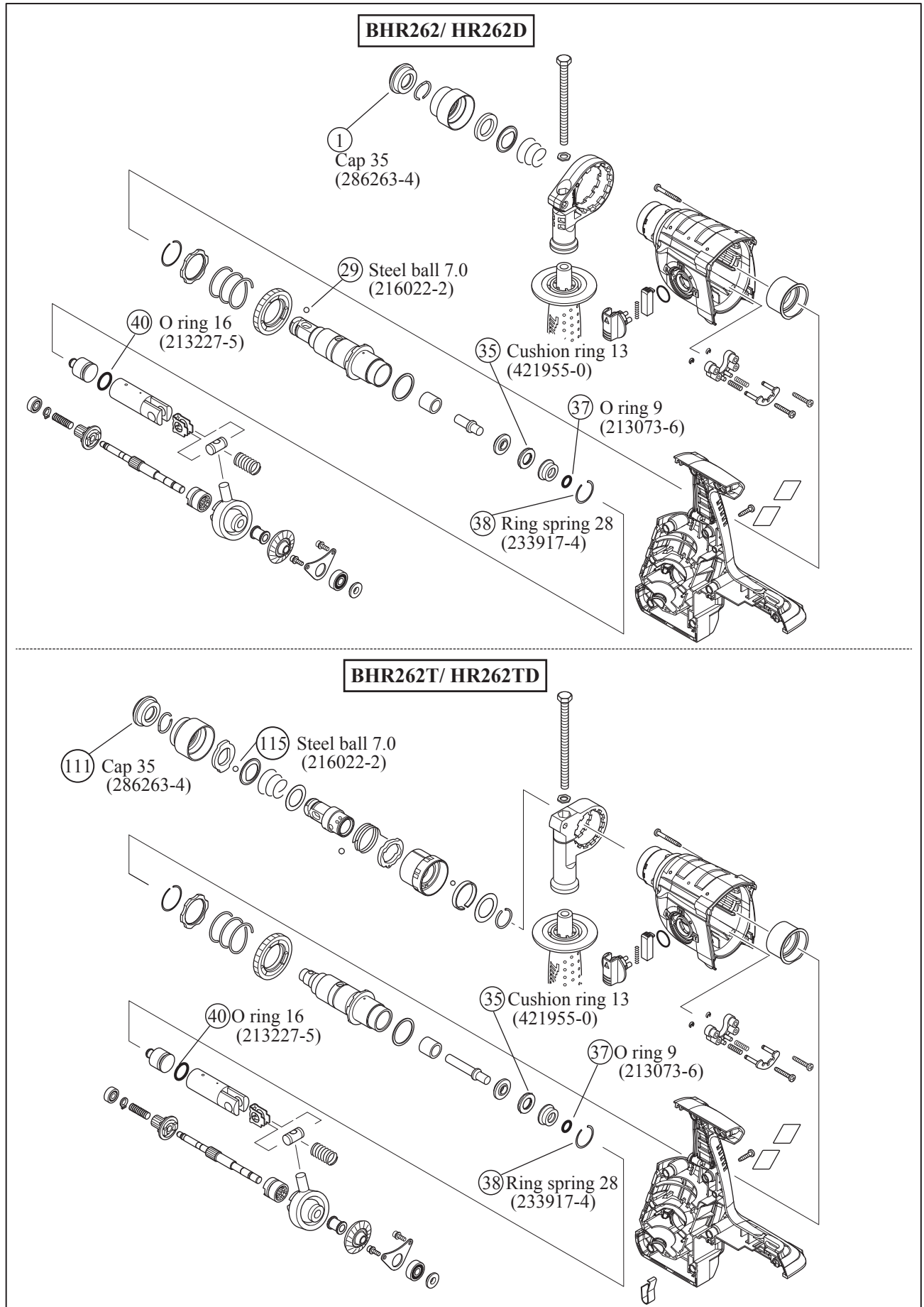

► **Circuit diagram**

Fig. D-1

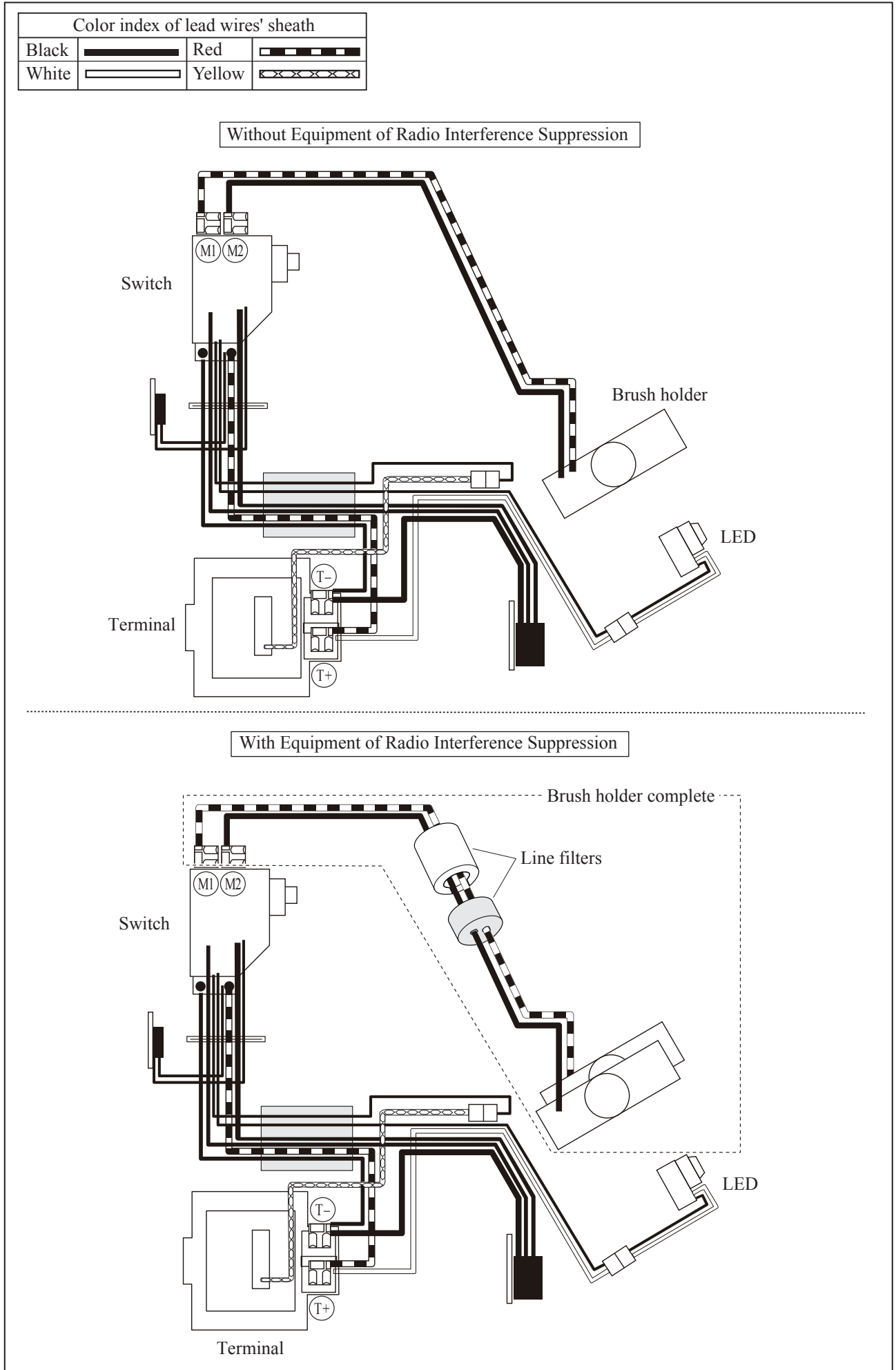

▶ Wiring diagram

Fig. D-2

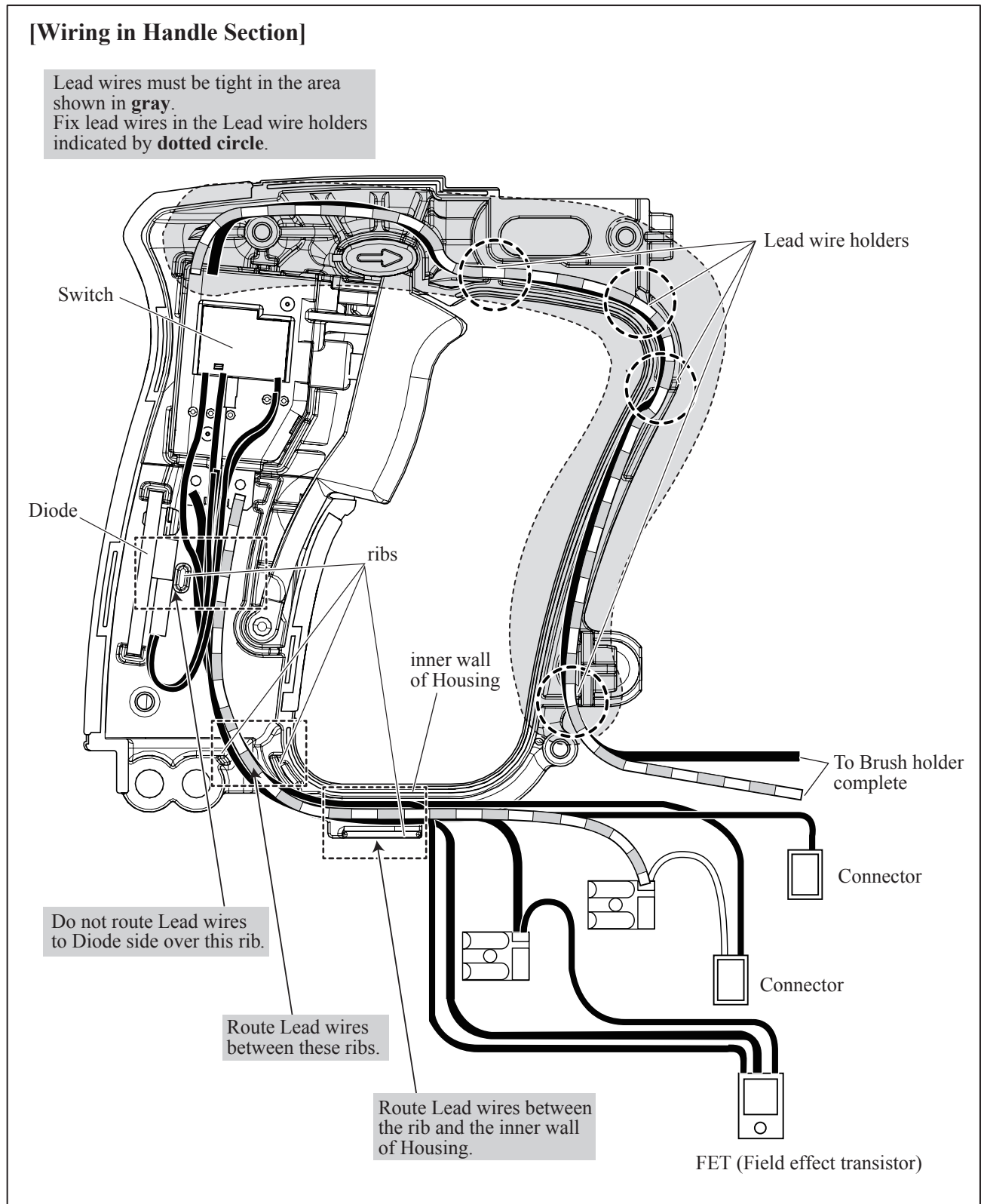

► **Wiring diagram**

Fig. D-3

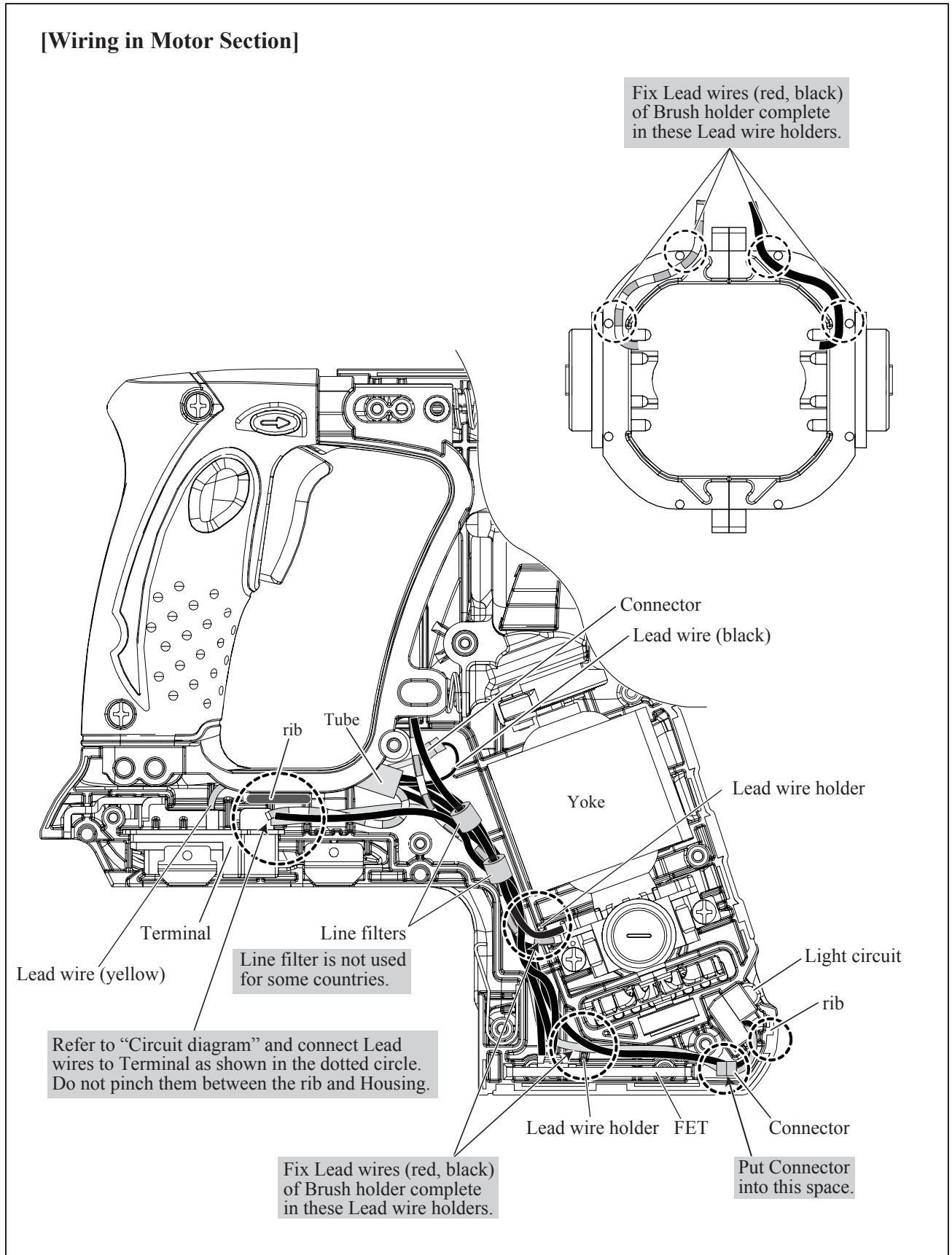

Free Manuals Download Website

<http://myh66.com>

<http://usermanuals.us>

<http://www.somanuals.com>

<http://www.4manuals.cc>

<http://www.manual-lib.com>

<http://www.404manual.com>

<http://www.luxmanual.com>

<http://aubethermostatmanual.com>

Golf course search by state

<http://golfingnear.com>

Email search by domain

<http://emailbydomain.com>

Auto manuals search

<http://auto.somanuals.com>

TV manuals search

<http://tv.somanuals.com>