

marantz
PROFESSIONAL

Model PMD620MKII User Guide

Handheld Solid State Recorder



CAUTION
RISK OF ELECTRIC SHOCK
DO NOT OPEN



CAUTION:

TO REDUCE THE RISK OF ELECTRIC SHOCK, DO NOT REMOVE COVER (OR BACK).

NO USER-SERVICEABLE PARTS INSIDE. REFER SERVICING TO QUALIFIED SERVICE PERSONNEL.



The lightning flash with arrowhead symbol, within an equilateral triangle, is intended to alert the user to the presence of uninsulated "dangerous voltage" within the product's enclosure that may be of sufficient magnitude to constitute a risk of electric shock to persons.



The exclamation point within an equilateral triangle is intended to alert the user to the presence of important operating and maintenance (servicing) instructions in the literature accompanying the appliance.

IMPORTANT TO SAFETY

WARNING:

To reduce the risk of fire and electric shock, this apparatus should not be exposed to rain or moisture and objects filled with liquids, such as vases, should not be placed on this apparatus.

CAUTION:

USE OF CONTROLS OR ADJUSTMENTS OR PERFORMANCE OF PROCEDURES OTHER THAN THOSE SPECIFIED HEREIN MAY RESULT IN HAZARDOUS RADIATION EXPOSURE.

THIS PRODUCT SHOULD NOT BE ADJUSTED OR REPAIRED BY ANYONE EXCEPT PROPERLY QUALIFIED SERVICE PERSONNEL.

FCC INFORMATION **(For US customers)**

1. COMPLIANCE INFORMATION

Product Name: Handheld Solid State Recorder
Model Number: PMD620MKII

This product complies with Part 15 of the FCC Rules. Operation is subject to the following two conditions: (1) this product may not cause harmful interference, and (2) this product must accept any interference received, including interference that may cause undesired operation.

Marantz Professional div. D&M Professional
1100 Maplewood Drive Itasca, IL 60143
Tel. 630-741-0330

2. IMPORTANT NOTICE: DO NOT MODIFY THIS PRODUCT

This product, when installed as indicated in the instructions contained in this manual, meets FCC requirements. Modification not expressly approved by Marantz may void your authority, granted by the FCC, to use the product.

3. IMPORTANT

When connecting this product to network hub or router, use only a shielded STP or ScTP LAN cable which is available at retailer. Follow all installation instructions. Failure to follow instructions could void your authority, granted by the FCC, to use the product.

4. NOTE

This product has been tested and found to comply with the limits for a Class B digital device, pursuant to Part 15 of the FCC Rules. These limits are designed to provide reasonable protection against harmful interference in a residential installation.

This product generates, uses and can radiate radio frequency energy and, if not installed and used in accordance with the instructions, may cause harmful interference to radio communications. However, there is no guarantee that interference will not occur in a particular installation. If this product does cause harmful interference to radio or television reception, which can be determined by turning the product OFF and ON, the user is encouraged to try to correct the interference by one or more of the following measures:

- Reorient or relocate the receiving antenna.
- Increase the separation between the equipment and receiver.
- Connect the product into an outlet on a circuit different from that to which the receiver is connected.
- Consult the local retailer authorized to distribute this type of product or an experienced radio/TV technician for help.

For Canadian customers:

This Class B apparatus complies with Canadian ICES-003.

Cet appareil numérique de la classe B est conforme à la norme NMB-003 du Canada.

IMPORTANT SAFETY INSTRUCTIONS

READ BEFORE OPERATING EQUIPMENT

This product was designed and manufactured to meet strict quality and safety standards. There are, however, some installation and operation precautions which you should be particularly aware of.

1. Read these instructions.
2. Keep these instructions.
3. Heed all warnings.
4. Follow all instructions.
5. Do not use this apparatus near water.
6. Clean only with dry cloth.
7. Do not block any ventilation openings. Install in accordance with the manufacturer's instructions.
8. Do not install near any heat sources such as radiators, heat registers, stoves, or other apparatus (including amplifiers) that produce heat.
9. Do not defeat the safety purpose of the polarized or grounding-type plug. A polarized plug has two blades with one wider than the other. A grounding type plug has two blades and a third grounding prong. The wide blade or the third prong are provided for your safety. If the provided plug does not fit into your outlet, consult an electrician for replacement of the obsolete outlet.
10. Protect the power cord from being walked on or pinched particularly at plugs, convenience receptacles, and the point where they exit from the apparatus.
11. Only use attachments/accessories specified by the manufacturer.
12. Use only with the cart, stand, tripod, bracket, or table specified by the manufacturer, or sold with the apparatus. When a cart is used, use caution when moving the cart/apparatus combination to avoid injury from tip-over.
13. Unplug this apparatus during lightning storms or when unused for long periods of time.
14. Refer all servicing to qualified service personnel. Servicing is required when the apparatus has been damaged in any way, such as power-supply cord or plug is damaged, liquid has been spilled or objects have fallen into the apparatus, the apparatus has been exposed to rain or moisture, does not operate normally, or has been dropped.



CAUTION

1. Handle the power supply cord carefully

Do not damage or deform the power supply cord. If it is damaged or deformed, it may cause electric shock or malfunction when used. When removing from wall outlet, be sure to remove by holding the plug attachment and not by pulling the cord.

2. Do not open the rear cover

In order to prevent electric shock, do not open the top cover.
If problems occur, contact your Marantz DEALER.

3. Do not place anything inside

Do not place metal objects or spill liquid inside the system.
Electric shock or malfunction may result.

Please, record and retain the Model name and serial number of your set shown on the rating label.

Model No. PMD620MKII

Serial No. _____

NOTE ON USE

English

WARNINGS

- Handle the power cord carefully.
- Hold the plug when unplugging the cord.
- Keep the unit free from moisture, water, and dust.
- Unplug the power cord when not using the unit for long periods of time.
- Do not obstruct the ventilation holes.
- Do not let foreign objects into the unit.
- Do not let insecticides, benzene, and thinner come in contact with the unit.
- Never disassemble or modify the unit in any way.
- Ventilation should not be impeded by covering the ventilation openings with items, such as newspapers, tablecloths or curtains.
- Naked flame sources such as lighted candles should not be placed on the unit.
- Do not expose the unit to dripping or splashing fluids.
- Do not place objects filled with liquids, such as vases, on the unit.
- Do not handle the mains cord with wet hands.
- When the switch is in the OFF position, the equipment is not completely switched off from MAINS.
- The equipment shall be installed near the power supply so that the power supply is easily accessible.

OBSERVATIONS RELATIVES A L'UTILISATION

Français

AVERTISSEMENTS

- Manipuler le cordon d'alimentation avec précaution.
- Tenir la prise lors du débranchement du cordon.
- Protéger l'appareil contre l'humidité, l'eau et la poussière.
- Débrancher le cordon d'alimentation lorsque l'appareil n'est pas utilisé pendant de longues périodes.
- Ne pas obstruer les trous d'aération.
- Ne pas laisser des objets étrangers dans l'appareil.
- Ne pas mettre en contact des insecticides, du benzène et un diluant avec l'appareil.
- Ne jamais démonter ou modifier l'appareil d'une manière ou d'une autre.
- Ne pas recouvrir les orifices de ventilation avec des objets tels que des journaux, nappes ou rideaux. Cela entraverait la ventilation.
- Ne jamais placer de flamme nue sur l'appareil, notamment des bougies allumées.
- L'appareil ne doit pas être exposé à l'eau ou à l'humidité.
- Ne pas poser d'objet contenant du liquide, par exemple un vase, sur l'appareil.
- Ne pas manipuler le cordon d'alimentation avec les mains mouillées.
- Lorsque l'interrupteur est sur la position OFF, l'appareil n'est pas complètement déconnecté du SECTEUR (MAINS).
- L'appareil sera installé près de la source d'alimentation, de sorte que cette dernière soit facilement accessible.

NOTAS SOBRE EL USO

Español

ADVERTENCIAS

- Maneje el cordón de energía con cuidado.
- Sostenga el enchufe cuando desconecte el cordón de energía.
- Mantenga el equipo libre de humedad, agua y polvo.
- Desconecte el cordón de energía cuando no utilice el equipo por mucho tiempo.
- No obstruya los orificios de ventilación.
- No deje objetos extraños dentro del equipo.
- No permita el contacto de insecticidas, gasolina y diluyentes con el equipo.
- Nunca desarme o modifique el equipo de ninguna manera.
- La ventilación no debe quedar obstruida por haberse cubierto las aperturas con objetos como periódicos, manteles o cortinas.
- No deberán colocarse sobre el aparato fuentes inflamables sin protección, como velas encendidas.
- No exponer el aparato al goteo o salpicaduras cuando se utilice.
- No colocar sobre el aparato objetos llenos de líquido, como jarras.
- No maneje el cable de alimentación con las manos mojadas.
- Cuando el interruptor está en la posición OFF, el equipo no está completamente desconectado de la alimentación MAINS.
- El equipo se instalará cerca de la fuente de alimentación de manera que resulte fácil acceder a ella.

HINWEISE ZUM GEBRAUCH

Deutsch

WARNHINWEISE

- Gehen Sie vorsichtig mit dem Netzkabel um.
- Halten Sie das Kabel am Stecker, wenn Sie den Stecker herausziehen.
- Halten Sie das Gerät von Feuchtigkeit, Wasser und Staub fern.
- Decken Sie den Lüftungsbereich nicht ab.
- Wenn das Gerät längere Zeit nicht verwendet werden soll, trennen Sie das Netzkabel vom Netzstecker.
- Lassen Sie keine fremden Gegenstände in das Gerät kommen.
- Lassen Sie das Gerät nicht mit Insektiziden, Benzin oder Verdünnungsmitteln in Berührung kommen.
- Versuchen Sie niemals das Gerät auseinander zu nehmen oder zu verändern.
- Die Belüftung sollte auf keinen Fall durch das Abdecken der Belüftungsöffnungen durch Gegenstände wie beispielsweise Zeitungen, Tischtücher, Vorhänge o. Ä. behindert werden.
- Auf dem Gerät sollten keinerlei direkte Feuerquellen wie beispielsweise angezündete Kerzen aufgestellt werden.
- Das Gerät sollte keiner tropfenden oder spritzenden Flüssigkeit ausgesetzt werden.
- Auf dem Gerät sollten keine mit Flüssigkeit gefüllten Behälter wie beispielsweise Vasen aufgestellt werden.
- Das Netzkabel nicht mit feuchten oder nassen Händen anfassen.
- Wenn der Schalter ausgeschaltet ist (OFF-Position), ist das Gerät nicht vollständig vom Stromnetz (MAINS) abgetrennt.
- Das Gerät sollte in der Nähe einer Netzsteckdose aufgestellt werden, damit es leicht an das Stromnetz angeschlossen werden kann.

NOTE SULL'USO

Italiano

AVVERTENZE

- Maneggiate il cavo di alimentazione con attenzione.
- Tenete ferma la spina quando scollegate il cavo dalla presa.
- Tenete l'unità lontana dall'umidità, dall'acqua e dalla polvere.
- Scollegate il cavo di alimentazione quando prevedete di non utilizzare l'unità per un lungo periodo di tempo.
- Non coprite i fori di ventilazione.
- Non inserite corpi estranei all'interno dell'unità.
- Assicuratevi che l'unità non entri in contatto con insetticidi, benzolo o solventi.
- Non smontate né modificate l'unità in alcun modo.
- Le aperture di ventilazione non devono essere ostruite coprendole con oggetti, quali giornali, tovaglie, tende e così via.
- Non posizionate sull'unità fiamme libere, come ad esempio candele accese.
- L'apparecchiatura non deve essere esposta a gocciolii o spruzzi.
- Non posizionate sull'unità alcun oggetto contenente liquidi, come ad esempio i vasi.
- Non toccare il cavo di alimentazione con le mani bagnate.
- Quando l'interruttore è nella posizione OFF, l'apparecchiatura non è completamente scollegata da MAINS.
- L'apparecchio va installato in prossimità della fonte di alimentazione, in modo che quest'ultima sia facilmente accessibile.

NOTA SOBRE UTILIZAÇÃO

Português

AVISOS

- Manuseie o cabo de alimentação com cuidado. Puxe pela ficha quando desligar o cabo de alimentação.
- Mantenha a unidade afastada da humidade, da água e do pó.
- Desligue o cabo de alimentação quando não estiver a utilizar a unidade por longos períodos de tempo.
- Não obstrua os orifícios de ventilação.
- Não deixe objectos estranhos dentro da unidade.
- Não permita que insecticidas, gasolina e diluente entrem em contacto com a unidade.
- Nunca desmonte ou modifique de alguma forma a unidade.
- A ventilação não deve ser obstruída, tapando as aberturas de ventilação com objectos, como jornais, toalhas ou cortinas.
- Não devem ser colocadas junto à unidade fontes de chama aberta, como velas acesas.
- Não exponha a unidade a gotejamento ou salpicos de líquidos.
- Não coloque objectos com líquidos, como jarras, em cima da unidade.
- Não manuseie o cabo de alimentação com as mãos molhadas.
- Quando o interruptor se encontra na posição OFF, o equipamento não está completamente desligado da REDE ELÉCTRICA.
- O equipamento deve ser instalado junto da fonte de alimentação, para que a fonte de alimentação esteja facilmente acessível.

OBSERVERA

Svenska

VARNINGAR

- Hantera nätkabeln varsamt.
- Håll i kabeln när den kopplas från el-uttaget.
- Utsätt inte apparaten för fukt, vatten och damm.
- Koppla loss nätkabeln om apparaten inte kommer att användas i lång tid.
- Täpp inte till ventilationsöppningarna.
- Se till att främmande föremål inte tränger in i apparaten.
- Se till att inte insektsmedel på spraybruk, bensen och thinner kommer i kontakt med apparatens hölje.
- Ta inte isär apparaten och försök inte bygga om den.
- Ventilationen bör inte förhindras genom att täcka för ventilationsöppningarna med föremål såsom tidningar, bordsdukar eller gardiner.
- Placera inte öppen eld, t.ex. tända ljus, på apparaten.
- Apparaten får inte utsättas för vätska.
- Placera inte föremål fyllda med vätska, t.ex. vasor, på apparaten.
- Hantera inte nåtsladden med våta händer.
- Även om strömbrytaren står i det avstängda läget OFF, så är utrustningen inte helt bortkopplad från det elektriska nätet (MAINS).
- Utrustningen ska vara installerad nära strömuttaget så att strömförsörjningen är lätt att tillgå.

ALVORENS TE GEBRUIKEN

Nederlands

WAARSCHUWINGEN

- Hanteer het netsnoer voorzichtig.
- Houd het snoer bij de stekker vast wanneer deze moet worden aan- of losgekoppeld.
- Laat geen vochtigheid, water of stof in het apparaat binnendringen.
- Neem altijd het netsnoer uit het stopcontact wanneer het apparaat gedurende een lange periode niet wordt gebruikt.
- De ventilatieopeningen mogen niet worden geblokkeerd.
- Laat geen vreemde voorwerpen in dit apparaat vallen.
- Voorkom dat insecticiden, benzene of verfdunner met dit toestel in contact komen.
- Dit toestel mag niet gedemonteerd of aangepast worden.
- De ventilatie mag niet worden belemmerd door de ventilatieopeningen af te dekken met bijvoorbeeld kranten, een tafelkleed of gordijnen.
- Plaats geen open vlammen, bijvoorbeeld een brandende kaars, op het apparaat.
- Stel het apparaat niet bloot aan druppels of spatten.
- Plaats geen voorwerpen gevuld met water, bijvoorbeeld een vaas, op het apparaat.
- Raak het netsnoer niet met natte handen aan.
- Als de schakelaar op OFF staat, is het apparaat niet volledig losgekoppeld van de netspanning (MAINS).
- De apparatuur wordt in de buurt van het stopcontact geïnstalleerd, zodat dit altijd gemakkelijk toegankelijk is.

DECLARATION OF CONFORMITY

English

We declare under our sole responsibility that this product, to which this declaration relates, is in conformity with the following standards: EN60065, EN55013, EN55020, EN61000-3-2 and EN61000-3-3. Following the provisions of Low Voltage Directive 2006/95/EC and EMC Directive 2004/108/EC, the EC regulation 1275/2008 and its frame work Directive 2009/125/EC for Energy-related Products (ErP).

DECLARATION DE CONFORMITE

Français

Nous déclarons sous notre seule responsabilité que l'appareil, auquel se réfère cette déclaration, est conforme aux standards suivants: EN60065, EN55013, EN55020, EN61000-3-2 et EN61000-3-3. Selon la directive 2006/95/EC concernant la basse tension et la directive CEM 2004/108/EC, la réglementation européenne 1275/2008 et la directive 2009/125/EC établissant un cadre de travail applicable aux produits liés à l'énergie (ErP).

DECLARACIÓN DE CONFORMIDAD

Español

Declaramos bajo nuestra exclusiva responsabilidad que este producto al que hace referencia esta declaración, está conforme con los siguientes estándares: EN60065, EN55013, EN55020, EN61000-3-2 y EN61000-3-3. De acuerdo con la directiva sobre baja tensión 2006/95/CE y la directiva sobre CEM 2004/108/CE, la normativa CE 1275/2008 y su directiva marco 2009/125/EC para productos relacionados con la energía (ErP).

ÜBEREINSTIMMUNGSERKLÄRUNG

Deutsch

Wir erklären unter unserer Verantwortung, daß dieses Produkt, auf das sich diese Erklärung bezieht, den folgenden Standards entspricht: EN60065, EN55013, EN55020, EN61000-3-2 und EN61000-3-3. Gemäß den Bestimmungen der Niederspannungsrichtlinie 2006/95/EG und EMV Richtlinie 2004/108/EG, der Verordnung (EG) Nr. 1275/2008 der Kommission und deren Rahmenrichtlinie 2009/125/EG zu energieverbrauchsrelevanten Produkten (ErP).

DICHIARAZIONE DI CONFORMITÀ

Italiano

Dichiariamo con piena responsabilità che questo prodotto, al quale la nostra dichiarazione si riferisce, è conforme alle seguenti normative: EN60065, EN55013, EN55020, EN61000-3-2 e EN61000-3-3. Facendo seguito alle disposizioni della direttiva sul basso voltaggio 2006/95/EC alla direttiva EMC 2004/108/EC, alla norma EC 1275/2008 e alla relativa legge quadro 2009/125/EC in materia di prodotti alimentati ad energia (ErP). QUESTO PRODOTTO E' CONFORME AL D.M. 28/08/95 N. 548

DECLARAÇÃO DE CONFORMIDADE

Português

Declaramos sob nossa exclusiva responsabilidade que este produto, ao qual se refere esta declaração, se encontra em conformidade com as seguintes normas: EN60065, EN55013, EN55020, EN61000-3-2 e EN61000-3-3. De acordo com as provisões da Directiva de Baixa Tensão 2006/95/CE e a Directiva CEM 2004/108/CE, o Regulamento (CE) 1275/2008 e a respectiva Directiva-Quadro 2009/125/CE para produtos relacionados com o consumo de energia (ErP).

ÖVERENSSTÄMMELSESINTYG

Svenska

Härmed intygas helt på eget ansvar att denna produkt, vilken detta intyg avser, uppfyller följande standarder: EN60065, EN55013, EN55020, EN61000-3-2 och EN61000-3-3. Uppfyller reglerna i lågspänningsdirektivet 2006/95/EC och EMC-direktivet 2004/108/EC, EU-förordningen 1275/2008 och ramverksdirektivet 2009/125/EC för energirelaterade produkter (ErP).

EENVORMIGHEIDSVERKLARING

Nederlands

Wij verklaren uitsluitend op onze verantwoordelijkheid dat dit product, waarop deze verklaring betrekking heeft, in overeenstemming is met de volgende normen: EN60065, EN55013, EN55020, EN61000-3-2 en EN61000-3-3. Volgens de voorzieningen van lage spanningsrichtlijn 2006/95/EC en EMC-richtlijn 2004/108/EC, de EU-richtlijn 1275/2008 en de kaderrichtlijn 2009/125/EC voor energieverbruikende producten (ErP).

D&M Professional Europe
A division of D&M Europe B.V.
Beemdstraat 11
5653 MA Eindhoven
The Netherlands

CAUTION:**English**

To completely disconnect this product from the mains, disconnect the plug from the wall socket outlet.

The mains plug is used to completely interrupt the power supply to the unit and must be within easy access by the user.

PRECAUTION:**Français**

Pour déconnecter complètement ce produit du courant secteur, débranchez la prise de la prise murale.

La prise secteur est utilisée pour couper complètement l'alimentation de l'appareil et l'utilisateur doit pouvoir y accéder facilement.

PRECAUCIÓN:**Español**

Para desconectar completamente este producto de la alimentación eléctrica, desconecte el enchufe del enchufe de la pared.

El enchufe de la alimentación se utiliza para interrumpir por completo el suministro de alimentación a la unidad y debe de encontrarse en un lugar al que el usuario tenga fácil acceso.

VORSICHT:**Deutsch**

Um dieses Gerät vollständig von der Stromversorgung abzutrennen, trennen Sie bitte den Netzstecker von der Wandsteckdose ab.

Die Hauptstecker werden verwendet, um die Stromversorgung zum Gerät völlig zu unterbrechen; er muss für den Benutzer gut und einfach zu erreichen sein.

ATTENZIONE:**Italiano**

Per scollegare definitivamente questo prodotto dalla rete di alimentazione elettrica, togliere la spina dalla relativa presa.

La spina di rete viene utilizzata per interrompere completamente l'alimentazione all'unità e deve essere facilmente accessibile all'utente.

ATENÇÃO:**Português**

Para desligar completamente este produto da corrente, desligue a ficha da tomada eléctrica.

A ficha eléctrica é utilizada para interromper completamente a alimentação da unidade e deve estar num local onde o utilizador lhe possa aceder facilmente. Não exponha as pilhas a fontes de calor excessivo, como luz solar, fogo ou semelhantes.

FÖRSIKTIHETSMÅTT:**Svenska**

Koppla loss stickproppen från eluttaget för att helt skilja produkten från nätet.

Stickproppen används för att helt bryta strömförsörjningen till apparaten, och den måste vara lättillgänglig för användaren.

VOORZICHTIGHEID:**Nederlands**

Om de voeding van dit product volledig te onderbreken moet de stekker uit het stopcontact worden getrokken.

De netstekker wordt gebruikt om de stroomtoevoer naar het toestel volledig te onderbreken en moet voor de gebruiker gemakkelijk bereikbaar zijn.

A NOTE ABOUT RECYCLING:

This product's packaging materials are recyclable and can be reused. Please dispose of any materials in accordance with the local recycling regulations.

When discarding the unit, comply with local rules or regulations.

Batteries should never be thrown away or incinerated but disposed of in accordance with the local regulations concerning battery disposal.

This product and the supplied accessories, excluding the batteries, constitute the applicable product according to the WEEE directive.

English



UNE REMARQUE CONCERNANT LE RECYCLAGE:

Les matériaux d'emballage de ce produit sont recyclables et peuvent être réutilisés. Veuillez disposer des matériaux conformément aux lois sur le recyclage en vigueur.

Lorsque vous mettez cet appareil au rebut, respectez les lois ou réglementations en vigueur.

Les piles ne doivent jamais être jetées ou incinérées, mais mises au rebut conformément aux lois en vigueur sur la mise au rebut des piles.

Ce produit et les accessoires inclus, à l'exception des piles, sont des produits conformes à la directive DEEE.

Français



ACERCA DEL RECICLAJE:

Los materiales de embalaje de este producto son reciclables y se pueden volver a utilizar. Disponga de estos materiales siguiendo los reglamentos de reciclaje de su localidad.

Cuando se deshaga de la unidad, cumpla con las reglas o reglamentos locales.

Las pilas nunca deberán tirarse ni incinerarse. Deberá disponer de ellas siguiendo los reglamentos de su localidad relacionados con los desperdicios químicos.

Este producto junto con los accesorios empaquetados es el producto aplicable a la directiva RAEE excepto pilas.

Español



Pb

HINWEIS ZUM RECYCLING:

Das Verpackungsmaterial dieses Produktes ist zum Recyceln geeignet und kann wieder verwendet werden. Bitte entsorgen Sie alle Materialien entsprechend der örtlichen Recycling-Vorschriften.

Beachten Sie bei der Entsorgung des Gerätes die örtlichen Vorschriften und Bestimmungen.

Die Batterien dürfen nicht in den Hausmüll geworfen oder verbrannt werden; bitte entsorgen Sie die Batterien gemäß der örtlichen Vorschriften.

Dieses Produkt und das im Lieferumfang enthaltene Zubehör (mit Ausnahme der Batterien!) entsprechen der WEEE-Direktive.

Deutsch

NOTA RELATIVA AL RICICLAGGIO:

I materiali di imballaggio di questo prodotto sono riutilizzabili e riciclabili. Smaltire i materiali conformemente alle normative locali sul riciclaggio.

Per lo smaltimento dell'unità, osservare le normative o le leggi locali in vigore.

Non gettare le batterie, né incenerirle, ma smaltirle conformemente alla normativa locale sui rifiuti chimici.

Questo prodotto e gli accessori inclusi nell'imballaggio sono applicabili alla direttiva RAEE, ad eccezione delle batterie.

Italiano



UMA NOTA SOBRE A RECICLAGEM:

Os materiais de embalagem deste produto são recicláveis e podem ser reutilizados. Elimine quaisquer materiais de acordo com as normas de reciclagem locais.

Quando eliminar a unidade, obedeça às regras ou normas locais.

As pilhas nunca devem ser deitadas fora ou incineradas, mas sim eliminadas de acordo com as normas locais relativas aos resíduos químicos.

Este produto e os respectivos acessórios embalados em conjunto constituem o produto aplicável de acordo com a directiva WEEE, excepto as pilhas.

Português



OBSERVERA ANGÅENDE ÅTERVINNING:

Produktens emballage är återvinningsbart och kan återanvändas. Kassera det enligt lokala återvinningsbestämmelser.

När du kasserar enheten ska du göra det i överensstämmelse med lokala regler och bestämmelser.

Batterier får absolut inte kastas i soporna eller brännas. Kassera dem enligt lokala bestämmelser för kemiskt avfall.

Denna apparat och de tillbehör som levereras med den uppfyller gällande WEEE-direktiv, med undantag av batterierna.

Svenska



EEN AANTEKENING MET BETREKKING TOT DE RECYCLING:

Het inpakmateriaal van dit product is recycleerbaar en kan opnieuw gebruikt worden. Er wordt verzocht om zich van elk afvalmateriaal te ontdoen volgens de plaatselijke voorschriften.

Volg voor het wegdoen van de speler de voorschriften voor de verwijdering van wit- en bruingoed op.

Batterijen mogen nooit worden weggegooid of verbrand, maar moeten volgens de plaatselijke voorschriften betreffende chemisch afval worden verwijderd.

Op dit product en de meegeleverde accessoires, m.u.v. de batterijen is de richtlijn voor afgedankte elektrische en elektronische apparaten (WEEE) van toepassing.

Nederlands

Pb

Table of Contents

Package Contents	4	Recording Format	25
Introduction	5	Recording Time Chart	26
Quick Start Guide	7	Recording Level Control	27
Names and Functions	9	Encrypted Recording	27
Front.....	9	Retake Recording	28
Left.....	11	Basic Playback Operation	30
Right	12	Connection Diagram	30
Top	13	Playback Procedure	30
Bottom	13	Access from File List.....	31
Rear Back	14	Search	32
Preparations Before Use	15	Skip Back	33
AC adapter connection	15	Passcode Input	33
Using batteries.....	15	Display	34
Installing a memory card.....	18	Advanced Features	37
Removing a memory card.....	18	Microphone(s).....	37
Clock Setting.....	19	Low Cut Filter.....	38
Font Size.....	20	Silent Skip.....	38
Tripod/Belt Clip Adapter	21	Manual Track.....	38
How to use a tripod	21	Auto Track	38
How to clip to your belt.....	21	Copy Segment	39
Basic Recording Operation	22	Key Lock	40
Connection Diagram	22	Remote	41
Recording Procedure.....	22	USB mode	43
Audio Input for Recording	24	How to connect via the USB port.....	43
		Diagram of file structure.....	44

Menu	45	11. Low Cut.....	63
Menu Structure	45	12. Mic Power.....	63
Menu List	46	13. Input Jack.....	64
Protecting the Menu Settings.....	46	14. Skip Back	64
File List.....	47	15. Key Lock.....	65
Play.....	48	16. Battery.....	65
Information.....	48	17. Auto Power Off.....	66
File Rename	49	18. Encrypt Rec	66
File Delete.....	50	19. Menu Lock.....	67
Utility Menu	51	20. Passcode	67
Load Settings.....	52	21. SP Mute	68
Save Settings.....	53	22. Machine ID.....	69
Card Check.....	53	23. Default.....	70
Card Format.....	54	Display Menu	71
Preset Menu	55	1. Brightness	72
Preset Rename.....	56	2. Font Size	72
Table of Preset	57	3. LED	73
1. Input	58	4. Time Form.....	73
2. Rec Format	58	5. Date Form	74
3. Rec Channel	59	6. File Sort.....	74
4. Sample Rate	59	7. Default.....	75
5. Level Control	60	Select Language	76
6. Level LED.....	60	Troubleshooting.....	77
7. Manual Track	61	Error Message.....	78
8. Auto Track.....	61	Factory Default	79
9. Silent Skip	62	Specifications	80
10. Mic Attenuator.....	62		

Limited Warranty.....81

Package Contents

- PMD620MKII

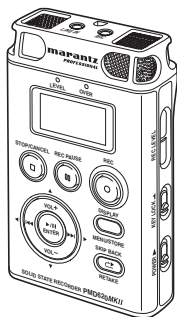

- User guide
- CD-ROM
- Handy strap

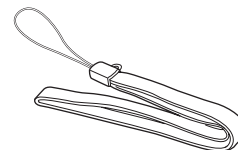

- Audio cable

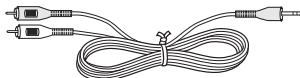

- Tripod/Belt clip adapter

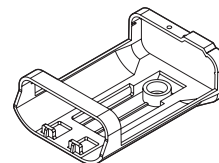

- USB cable

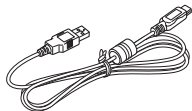

- SD card



- AC adapter



Introduction

Thank you for selecting the Marantz Professional PMD620MKII Handheld Solid State Recorder.

The PMD620MKII is an audio recorder that records in digital audio formats onto a SD (Secure Digital) memory card. SD cards, also used in digital cameras, are widely available at consumer electronics retailers and computer resellers.

Features

- Stereo (2 channels) and mono (1 channel) audio recording and playback.
- Audio inputs may be from :
 - the built-in microphone(s),
 - condenser or dynamic microphone(s) connected to the MIC IN jack, or
 - line level audio sources connected to the LINE IN jack.
- Audio outputs may be from :
 - the built-in speaker,
 - headphones connected to the PHONES jack, or
 - analog audio devices such as an amplifier or other devices connected to the LINE OUT jack.
- Records onto various types of SD cards.

- Computer compatible
The PMD620MKII records directly onto SD cards. Recordings can be transferred to your desktop or laptop computer by removing the SD card from the PMD620MKII or by connecting the PMD620MKII to your computer via the USB port. Audio recorded in the popular MP3 compression format is directly available for intranet or internet file sharing. MS-DOS™ and Windows compatible file system.
- Easy one control recording
Simply press the **REC** button.
- Automatic recording
The PMD620MKII can be set to stop recording when there is silence (Silent Skip) and automatically start when sound resumes.
- Manual and automatic record level control (ALC).
- Different recording formats :
 - Compressed recording using MP3 (MPEG1 Layer III) mono and stereo. MP3 compressed at 64/128/192kbps (Stereo) or 32/64/96kbps (Mono).
 - Uncompressed recording using 16/24-bit linear PCM (Pulse Code Modulation).
- Copy Segment
Copy Segment works just like the copy and paste function of your standard word processing program. It allows you to “highlight” a section of a file by setting an in point and an out point, and then paste that section into a new file without destroying the original file(s).
- Data secured
The recorded audio data until the recording stops is kept even if the power is interrupted suddenly during recording.
- Compatible with SDHC UHS-I card
- Retake function ( P.28)
- File encryption
- DMP Mark Editor software included

Quick Start Guide

Follow the instructions on this page to Quick Start your new PMD620MKII Solid State Recorder and begin recording. The PMD620MKII comes with factory preset defaults for MP3 recording using internal microphones.

1. Unpack the AC adapter and the PMD620MKII.
2. Setup the power supply.
 - Use either the provided AC adapter or batteries.
 - You can use 2 AA type batteries of Alkaline, or Nickel-Metal Hydride.

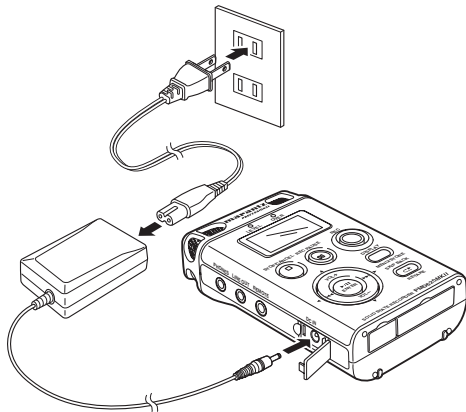

3. Slide and hold the **POWER** switch.

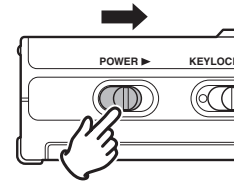

4. Press the **REC** button to begin recording.

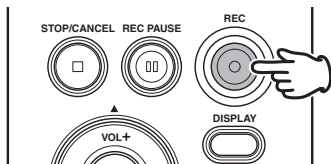

5. Press the **STOP/CANCEL** button to stop recording.

6. Press the **▶/||/ENTER** button to play the just recorded file via headphones or speaker.

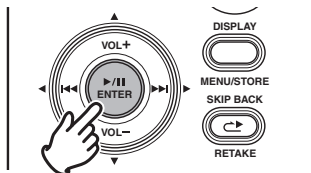

7. Press the **▶/||/ENTER** button again to pause playback.

8. Press the **STOP/CANCEL** button to stop playback.

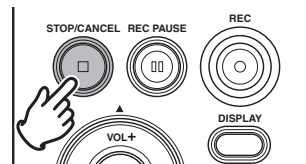

- For other recording condition, see page 22.
- For the clock setting, see page 19.
- For to select the display font size or brightness of the display, see page 72.

Names and Functions

Front

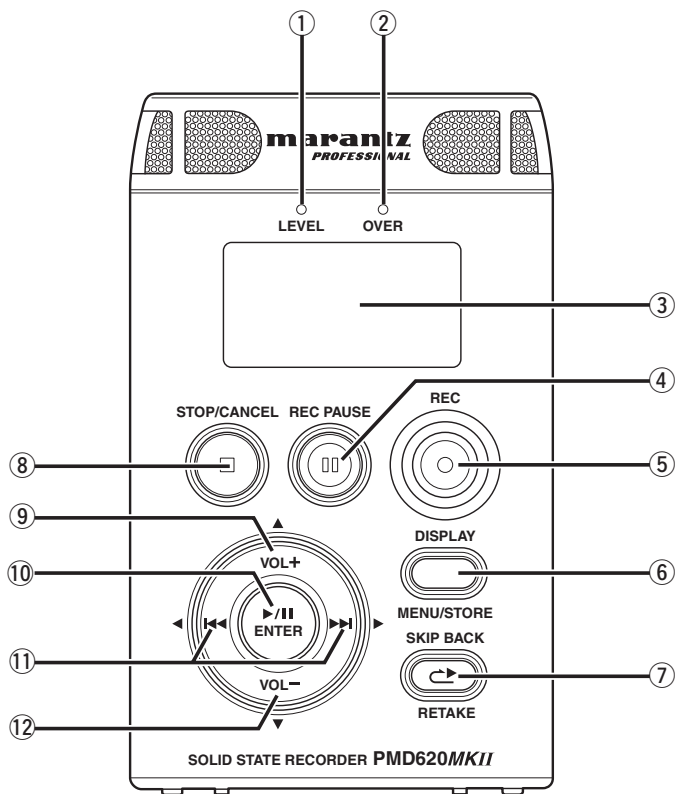

① LEVEL LED (Green)

When a sound is input during Record or Rec-Pause mode, it turns on. A level to turn on is decided in presetting. (☞ P.60)

② OVER LED (Red)

When a sound is over peak level during Record or Rec-Pause mode, it turns on.

③ DISPLAY

The display shows information of the PMD620MKII. (☞ P.34)

④ REC PAUSE button

Press to enter the Rec-Pause mode from Stop or Record mode.

⑤ REC button

Press to start recording from Stop or Rec-Pause mode. The **REC** button also works to create new file during recording if the "Manual Track" in the menu is placed in "On".

Press to set IN/OUT point for Copy Segment function during Playback or Play-Pause mode. (☞ P.39)

⑥ **DISPLAY/MENU/STORE button**

Press to change the display contents like the time information with toggle operation. The content is different depending on each operation mode. (👉 P.34)

From Stop mode press and hold to access the menu. The menu lets you set or change recording and playback parameters, such as changing inputs and setting the Date and Time. During the menu mode, press to exit the menu mode with saving preset changes. (👉 P.55)

⑦ **SKIP BACK button**

Press to skip back during Playback or Play-Pause mode. Also, when this button is pressed during the Rec-Pause mode, the Retake Record mode is set.

⑧ **STOP/CANCEL button**

Press to stop the Playback or Record mode and to release the Play-Pause or Rec-Pause mode. During menu mode, press to exit menu mode without saving preset changes.

⑨ **VOL + button**

Press to make a level big of both headphones and speaker.
During menu mode, this button is used to change item.

⑩ **▶/||/ENTER button**

From stop, press to begin playback.

During Playback mode, press to pause playback. Also, if this button is pressed when playback is paused, playback restarts.

During Menu mode, this is used to decide the choice.

⑪ **◀◀ button**

- In Stop, Playback or Play-Pause mode, press to choose the file (Jump to previous file)
- In Play-Pause mode, press and hold this for high speed reverse searching without audio. (Search -)
- In Playback mode, press and hold this to “rewind” and do a 2X speed search. (Audible Search -)

▶▶ button

Same as ◀◀ button except a difference of a direction.

⑫ **VOL – button**

Press to make a level small of both headphones and speaker.
During menu mode, this button is used to change item.

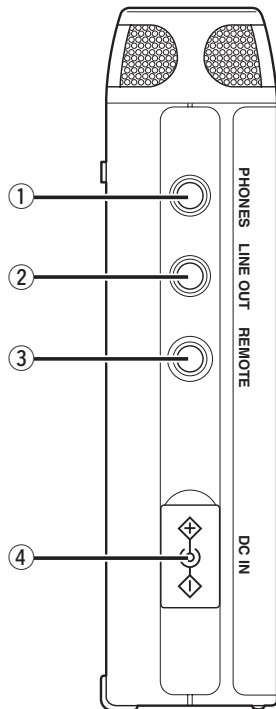

① **PHONES jack**

Insert the stereo headphones plug here.

② **LINE OUT jack**

Insert an audio cable plug connected to an external audio device into this jack to output audio signals to an external device (amp, etc.).

③ **REMOTE jack**

Connect microphone remote RC600PMD (sold separately) to this jack. There is a recording indicator lamp on the RC600PMD.

④ **DC IN jack**

Insert the provided AC adapter plug. The power supply is DC5V, 1.5A.

If the AC adapter plug is inserted while using the recorder on battery power, the recorder will automatically switch to adapter power. Also, if the AC adapter plug is removed, the recorder will automatically switch to battery power.

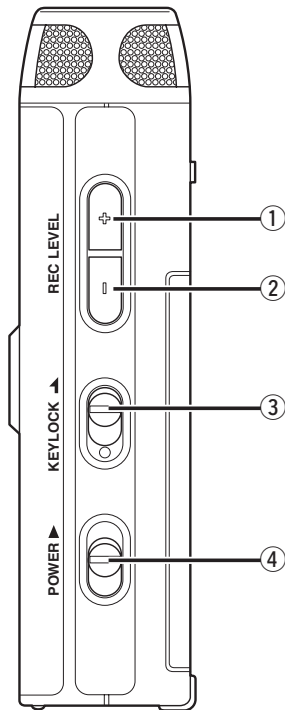

- ① **REC LEVEL + button**
Press to make a level big of input audio during Record or Rec-Pause mode.
- ② **REC LEVEL – button**
Press to make a level small of input audio during Record or Rec-Pause mode.
- ③ **KEY LOCK switch**
Slide switch for the Key Lock On and Off control.
- ④ **POWER slide switch**
Slide and hold to turn power On or Off.
During Record and Rec-Pause mode, the **POWER** switch is invalid.

Top

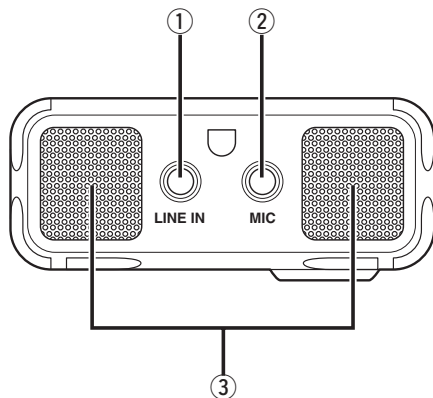

① LINE IN jack

Insert an audio cable plug connected to an external audio device into this jack to input the signals output from the external device into the recorder.

② MIC jack

Insert the external microphones plug.

③ Internal MIC

Stereo internal microphones.

Bottom

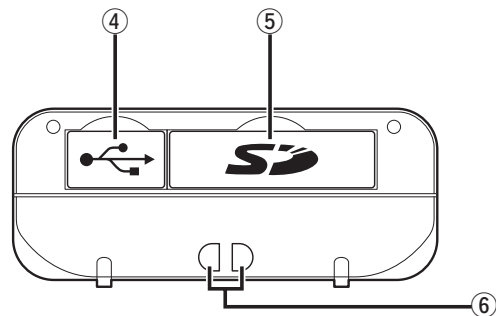

④ USB compartment

Pull the lid to connect PC via USB cable.

⑤ Card compartment

Pull the lid to access the SD card.

⑥ Strap hole

This hole is for handy strap.

Rear Back

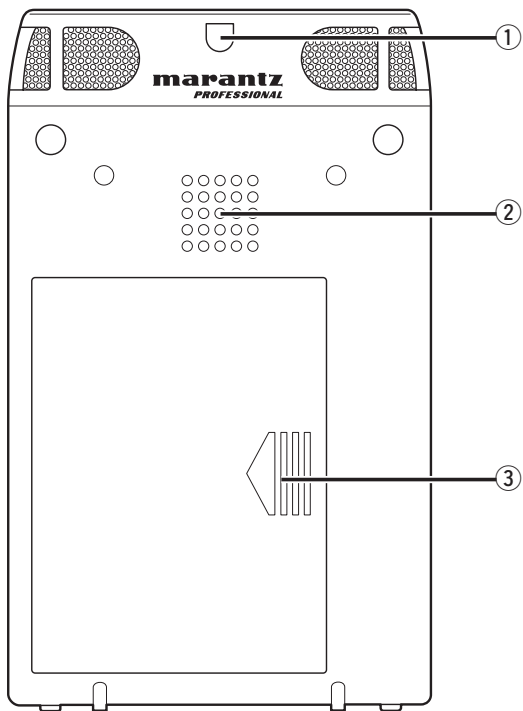

- ① **Strap hole**
This hole is for handy strap.
- ② **Speaker**
Monaural build-in speaker.
- ③ **Battery compartment**
Slide and pull the lid to open the Battery compartment.

Preparations Before Use

AC adapter connection

When using the recorder with the provided AC adapter, follow the procedure below to connect the AC adapter. If you wish to use batteries, please refer to the Using batteries section.

Notes:

- Only use the AC adapter that is provided with the recorder.
- Running the recorder on DC power without using the provided AC adapter will cause damage to the recorder.

- 1.** Connect the plug of AC power pack into the DC IN jack on the recorder.
- 2.** Connect the Power cord to a regular household plug socket.

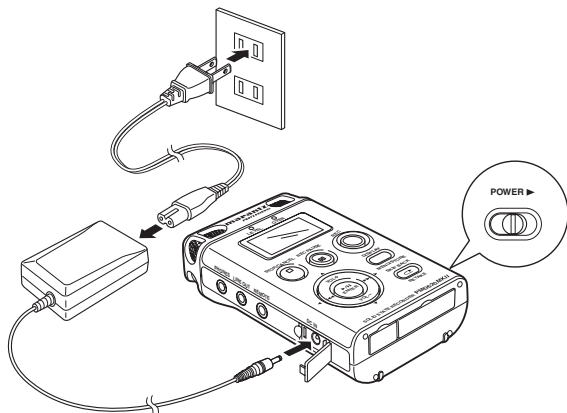

Using batteries

If you wish to run the recorder on battery power, follow the procedure below to install batteries into the recorder. The following types of battery can be used.

- Alkaline batteries (AA type)
- Nickel-Metal Hydride batteries (AA type)

Notes:

- When alkaline batteries (1450mAh type) are used recording: about 5 hours
- When running the recorder on batteries, always set the battery type in the preset menu to the correct setting for the batteries used. (☞ P.65)
- If the batteries run out during recording, recording automatically stops and the file information is updated before the recorder shuts down.
- AC adapter is priority than battery. In both power driven, when the AC adapter is taken off, the battery can backup and keep the all behavior on the PMD620MKII.

- 1.** Check that the power is turned off.
- 2.** Slide and pull the battery compartment.

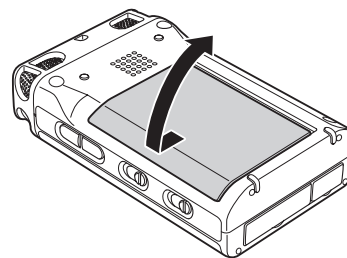

- 3.** Insert 2 batteries into the recorder correctly as shown in the diagram below, while paying attention to the polarity displays (\oplus : plus, and \ominus : minus).

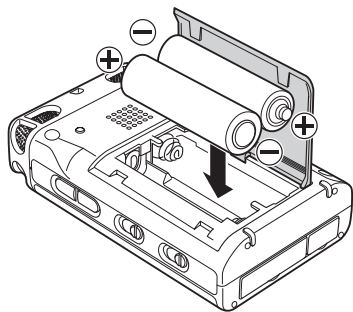

- 4.** Close the battery compartment.

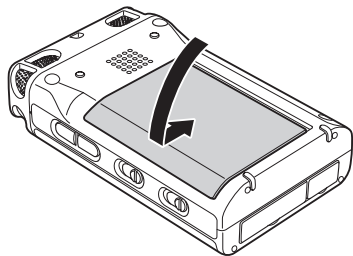

- 5.** Slide and hold the **POWER** switch to turn on.

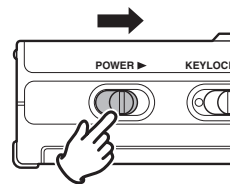

- 6.** Set the battery type for the recorder to match the type of batteries you are using. (☞ P.65)





Safety cautions on handling batteries

Always follow the points below when using batteries to avoid electrolyte leakage, overheating, fire, rupturing, ingestion, etc.

- Electrolyte leakage or corrosion may occur if batteries are kept inside the recorder for prolonged periods of time. If the recorder is not to be used for a prolonged period, remove the batteries to prevent electrolyte leakage.
- Make sure that the + and – markings on the batteries are aligned with the corresponding markings in the battery case and the battery holder.
- Do not insert old or exhausted batteries into the recorder.
- Do not mix the type of battery, and do not use both old and new batteries together.
- If the recorder does not operate correctly, replace the old batteries with new ones.
- If electrolyte has leaked, thoroughly wipe the inside of the battery holder, and then insert new batteries.
- Do not keep the battery in a place exposed to direct sunlight or in places with extremely high temperatures, such as near a heater.
- Used batteries should be disposed of in accordance with the local regulations regarding battery disposal.

Battery remaining indicator

The recorder operates using commercially available AA size alkaline or Ni-MH batteries. During operation, the battery remaining indicator is as follows.

Indicator	Meaning
	There is still ample battery power remaining.
	The amount of battery power remaining has decreased to approximately half.
	Only a small amount of battery power remaining.
	There is not enough battery power remaining to record or playback. Either replace the batteries with new ones, or recharge the rechargeable batteries. If you continue recording while this indicator is flashing, recording/playback will stop, and the recorder will shut down.
	The AC adapter is being used. The adapter power supply is valid.

Installing a memory card

The PMD620MKII records onto various types of SD cards.

1. Check that the power is turned off.
2. Pull the SD card lid.

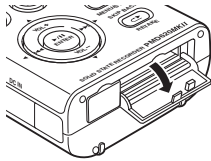

3. Fully insert the SD card.

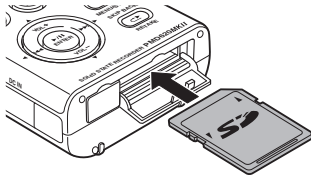

4. Close the SD card lid.

Removing a memory card

1. Check that the power is turned off.
2. Pull the SD card lid.
3. Push the card, then pull it to remove it.

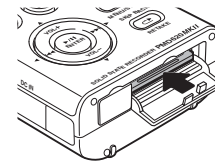

4. Close the SD card lid.

Notes:

- If the SD card lid opens while power is on, “Door Open” is displayed.
- If recording is in progress, opening the SD card lid automatically stops recording and writes critical file information to properly close the file.

Clock Setting

Set the current time (year, month, day, hour, minute).

1. From Stop, press and hold the **DISPLAY** button for one second.

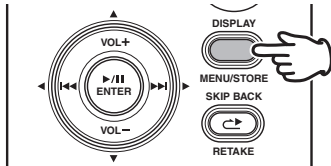

2. Press the **VOL +** or **VOL -** button to select "Time/Date".



3. Press the **>|/|<** button to enter the Time/Date setting.



- Press the **STOP/CANCEL** button to cancel.
 - Press the **<<<** or **>>>** button to select the item.
 - When the hour is set, press the **<<<** button to return to the Top Menu.
 - When the year is selected, the **>>>** button does not work.
 - Press the **VOL +** or **VOL -** button to select the value.
4. Press the **DISPLAY** button to write on the Real Time Clock.

Note:

If it happens to be the date which does not exist such as Feb. 31, it gets revised as back to Feb. 28.

Font Size

You can increase the font size of the text on the file list screen and preset setting screen.

1. From Stop, press and hold the **DISPLAY** button for one second.

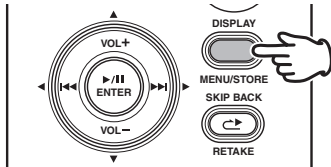

2. Press the **VOL +** or **VOL -** button to select “Display”. Then press the **►/II/ENTER** button to accept.



3. Press the **VOL +** or **VOL -** button to select the Font Size item. Then press the **◀◀** or **▶▶** button to tab through the Font Size choices (Large or Small).
4. Press the **DISPLAY** button to store the changes.
 - Press the **STOP/CANCEL** button to cancel.

Note:

For example, the file list screens are follows.

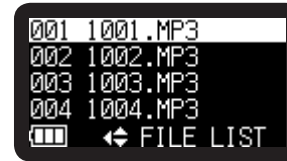

Large font

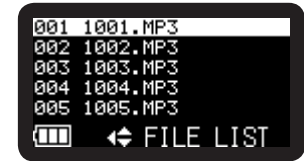

Small font

Tripod/Belt Clip Adapter

You can use a tripod to fix the PMD620MKII in the case of the record for a long period of time. To use the tripod, follow these steps to attach the tripod adaptor to the PMD620MKII.

How to use a tripod

1. Attach the tripod adaptor to the PMD620MKII.

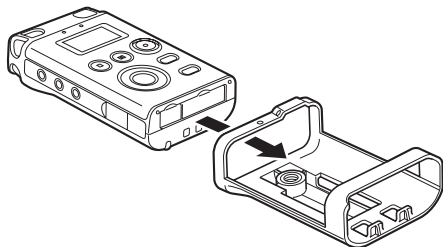

2. Fit the threaded hole in the bottom of the tripod adaptor to the screw on the tripod.

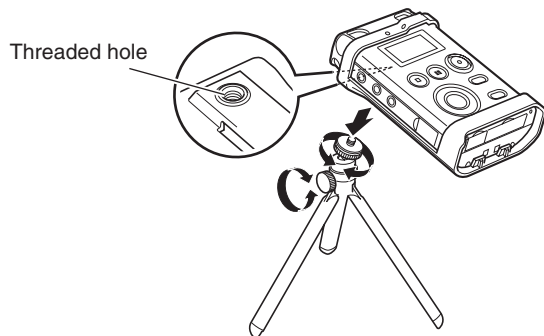

How to clip to your belt

Use this clip to attach the PMD620MKII to your belt.

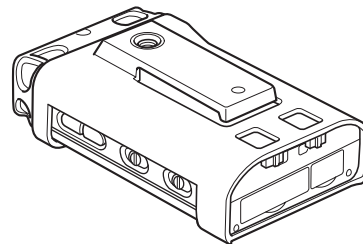

Notes:

- When the tripod is used, the battery door cannot be opened.
- Insert batteries before attaching the PMD620MKII to the tripod.

Basic Recording Operation

Connection Diagram

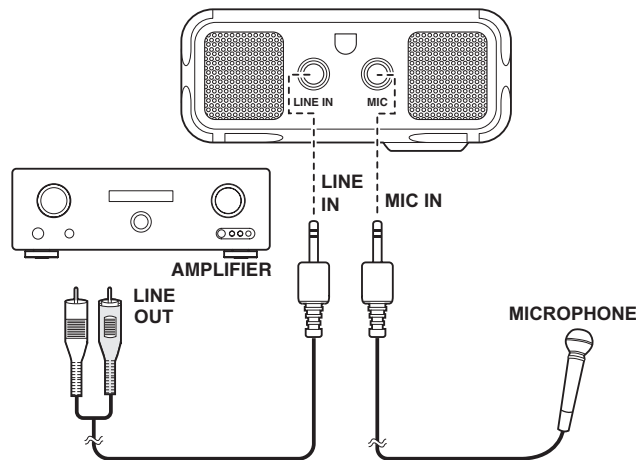

Recording Procedure

1. Slide and hold the **POWER** switch to turn on.

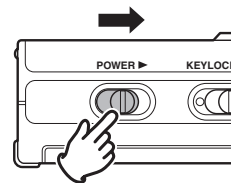

2. Press the **REC** button to begin recording.

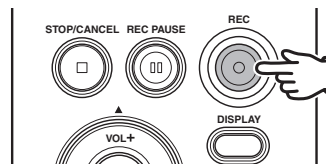

- The Rec indicator will be lit and steady while recording.

- The display will show the information display of recording.
(☞ P.35)

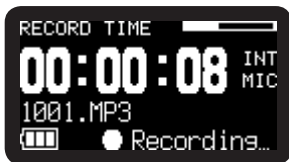

3. Press the **REC PAUSE** button to pause recording.

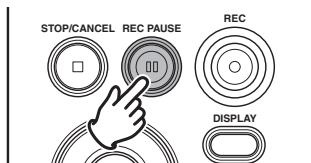

4. Press the **STOP/CANCEL** button to stop recording and end the file (close the audio file).

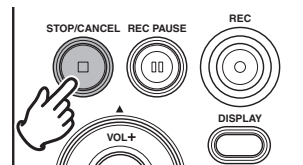

The display switches to information about the just recorded file. You can press the ►/||/ENTER button to play the just recorded file, or push the **STOP/CANCEL** button again to enter Stop mode. Then pressing the ►/||/ENTER button will play the beginning of the first audio file.

Audio Input for Recording

The audio input for recording can be set from the “Input” menu. (👉 P.58)

If “Input” of menu is Auto and External MIC is connected, Recording source is External MIC. When LINE jack is connected, Recording source is LINE audio. When the both connected at the same time the External MIC is active as priority.

You can perform 4 types of recording using combinations of the Preset “Rec Channel” (👉 P.59) and “Input Jack” (👉 P.64). Set the Rec Channel to “stereo” to create a stereo (2-channel) sound file. Or set it to “mono” to create a monaural (1-channel) sound file. The monaural file will be almost half the size as the stereo file. Set the input jack to “stereo” to record both channels. Or set it to “mono” to record the left channel only.

Rec Channel Setting	Input Jack Setting	Description
Stereo	Stereo	A stereo 2-channel file is created. The Left channel audio is recorded into one channel and the Right channel audio is recorded into another channel. This is standard stereo.
	Mono	A stereo 2-channel file is created. The 1-channel audio input is recorded into both channels. When the input is 2-channel stereo, only the Left channel is recorded into both channels.
Mono	Stereo	A monaural 1-channel file is created. The Left channel and Right channel are mixed.
	Mono	A monaural 1-channel file is created. When the input is 2-channel stereo, only the Left channel is recorded.

Recording Format

The PMD620MKII can record in several compression algorithms.

- Compressed recording using MP3 or uncompressed recording 16/24-bit linear PCM (👉 P.58).
- Stereo or Mono format. (👉 P.59).

Rec Format	Sample Rate	Channel	Bitrates	File Extension
MP3-H	44.1KHz	Stereo	192 kbps	mp3/mps
		Mono	96 kbps	mp3/mps
	48KHz	Stereo	192 kbps	mp3/mps
		Mono	96 kbps	mp3/mps
MP3-M	44.1KHz	Stereo	128 kbps	mp3/mps
		Mono	64 kbps	mp3/mps
	48KHz	Stereo	128 kbps	mp3/mps
		Mono	64 kbps	mp3/mps
MP3-L	44.1KHz	Stereo	64 kbps	mp3/mps
		Mono	32 kbps	mp3/mps
	48KHz	Stereo	64 kbps	mp3/mps
		Mono	32 kbps	mp3/mps
PCM-16	44.1KHz	Stereo	1411 kbps	wav/was
		Mono	705 kbps	wav/was
	48KHz	Stereo	1536 kbps	wav/was
		Mono	768 kbps	wav/was
PCM-24	44.1KHz	Stereo	2117 kbps	wav/was
		Mono	1058 kbps	wav/was
	48KHz	Stereo	2304 kbps	wav/was
		Mono	1152 kbps	wav/was

The record file of PCM is BWF (Broadcast Wave Format).

Recording Time Chart

All times are approximated record times.

Different media manufacturers allow more or less space for error correction and the like on their respective products.

Recording Time (hours : minutes)

Stereo channel

Settings	Bit Rate	Card Size					
		1GB	2GB	4GB	8GB	16GB	32GB
PCM-24 (48kHz)	2304kbps	0:59	1:59	3:57	7:54	15:48	31:36
PCM-24 (44.1kHz)	2117kbps	1:04	2:09	4:18	8:36	17:12	34:24
PCM-16 (48kHz)	1536kbps	1:29	2:58	5:56	11:51	23:42	47:24
PCM-16 (44.1kHz)	1411kbps	1:37	3:13	6:27	12:54	25:48	51:36
MP3-H	192kbps	11:51	23:42	47:24	94:49	189:38	379:16
MP3-M	128kbps	17:47	35:33	71:07	142:13	284:27	568:53
MP3-L	64kbps	35:33	71:07	142:13	284:27	568:53	1137:47

Mono channel

Settings	Bit Rate	Card Size					
		1GB	2GB	4GB	8GB	16GB	32GB
PCM-24 (48kHz)	1152kbps	1:59	3:57	7:54	15:48	31:36	63:13
PCM-24 (44.1kHz)	1058kbps	2:09	4:18	8:36	17:12	34:24	68:48
PCM-16 (48kHz)	768kbps	2:58	5:56	11:51	23:42	47:24	94:49
PCM-16 (44.1kHz)	705kbps	3:13	6:27	12:54	25:48	51:36	103:12
MP3-H	96kbps	23:42	47:24	94:49	189:38	379:16	758:31
MP3-M	64kbps	35:33	71:07	142:13	284:27	568:53	1137:47
MP3-L	32kbps	71:07	142:13	284:27	568:53	1137:47	2275:33

Recording Level Control

The recording level control lets you select the type of input level control.

– At the Manual Level Control

When Manual is set in the Level Control setting, press the **REC LEVEL +** or **REC LEVEL –** button to control the audio input level. The optimum record level is when the level meter goes as close to 0dB as possible but does not go OVER. When Level display is off, press the **REC LEVEL +** or **REC LEVEL –** button to display the level information for 1 second without changing recording level.

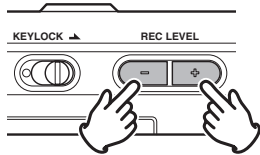

– At ALC (Automatic Level Control)

The PMD620MKII automatically responds to changes in input level. The **REC LEVEL** controls do not work when the ALC is selected. Set the Level Control of the preset menu “ALC” (P.60).

Encrypted Recording

When “Encrypt Rec” on the preset menu is set to “On”, files recorded on SD cards are encrypted.

Encryption is performed based on the passcode (0000 to 9999) set at “Passcode” on the preset menu.

The correct passcode must be input to play files recorded with encrypted recording. (P.33)

Files recorded with encrypted recording have the extension WAS for WAV files or MPS for MP3 files, according to the setting at “Rec Format” on the preset menu.

Use DMP Mark Editor to play files recorded with encrypted recording on a computer.

Retake Recording

The PMD620MKII is equipped with a retake recording function for recording over from any position in a file.

– Retake recording operation during recording

1. Press the **REC** button to begin recording.

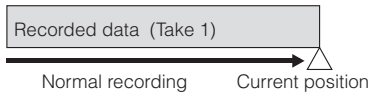

2. Press the **REC PAUSE** button to pause recording.

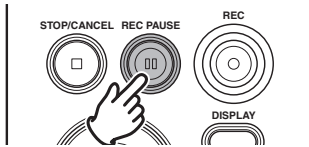

3. Press the **SKIP BACK** button to set the Retake Record mode.

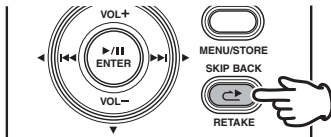

The recording position skips back the amount of time set at "Skip Back" on the preset menu and playback starts.



4. While monitoring the sound being played, find the position at which you want to start retake recording.

- Press the **▶/||/ENTER** button to pause playback.
- Press the **SKIP BACK, ◀◀** or **▶▶** button to search for the desired playback position.

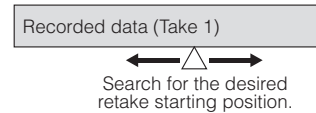

Press the **REC PAUSE** button to set the retake starting position.

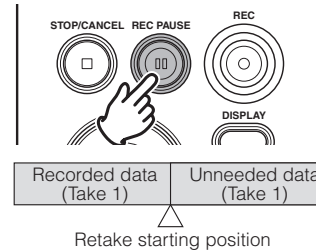

5. Press the **REC** button to start retake recording.

The unneeded data (Take 1) is deleted and Take 2 is recorded in its place.

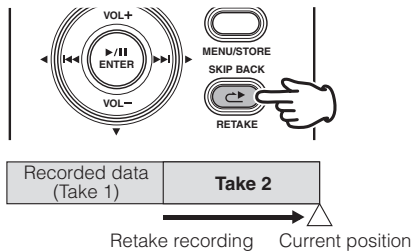

- When recording of Take 2 starts, 0.5 seconds or the time set at “PreRecord” on the preset menu is prerecorded.

– Retake recording operation during playback

- 1.** Press the **⏮** or **⏭** button to choose the file you wish to play.
- 2.** Press the **▶/⏸/ENTER** button to begin playback.

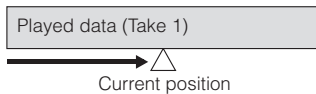

3. While monitoring the sound being played, find the position at which you want to start retake recording.

- Press the **▶/⏸/ENTER** button to pause playback.
- Press the **SKIP BACK**, **⏮** or **⏭** button to search for the desired playback position.

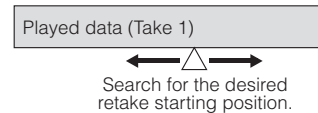

Press the **REC PAUSE** button to set the retake starting position.

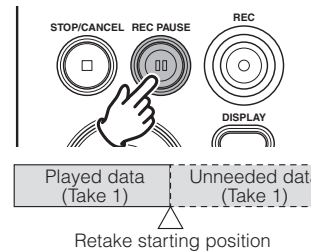

- 4.** Press the **REC** button to start retake recording. The unneeded data (Take 1) is deleted and Take 2 is recorded in its place.

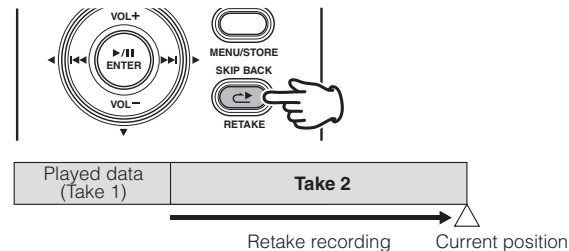

- When recording of Take 2 starts, 0.5 seconds or the time set at “PreRecord” on the preset menu is prerecorded.

Basic Playback Operation

Connection Diagram

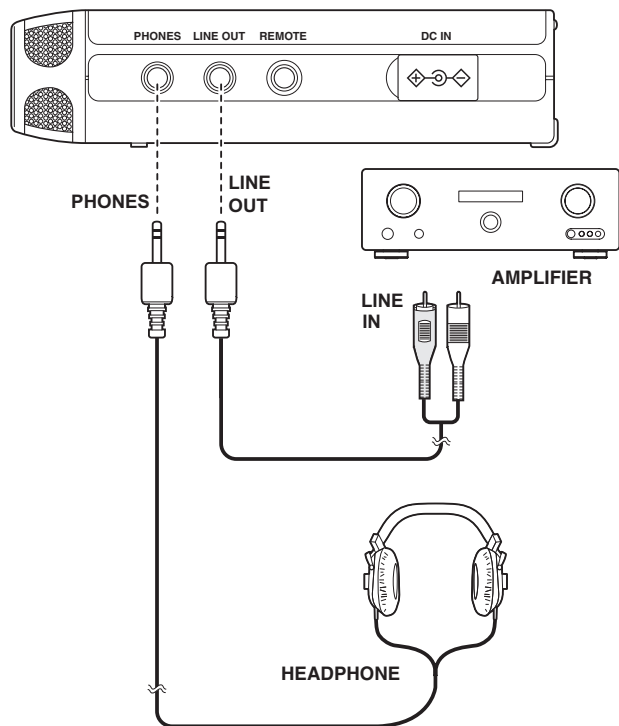

Caution:

To prevent hearing loss, do not raise the volume level excessively when using headphones.

Playback Procedure

1. Slide and hold the **POWER** switch to turn on.

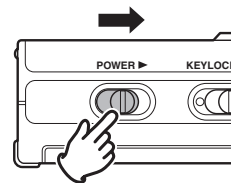

2. Press the **◀◀** or **▶▶** button to choose the file.

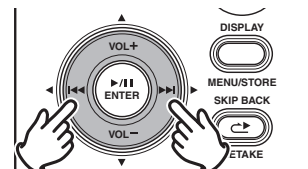

3. Press the ►/II/ENTER button to begin playback.

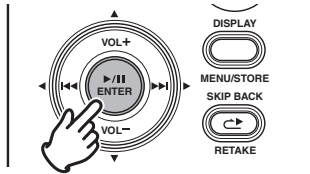

- When the selected file has been recorded with encrypted recording, the correct passcode must be input. (☞ P.33)
- Files recorded with encrypted recording have the extension WAS for WAV files or MPS for MP3 files.
- If an incorrect passcode is input, the file is not played.

4. Press the ►/II/ENTER button again to pause playback.

5. Press the STOP/CANCEL button to stop playback.

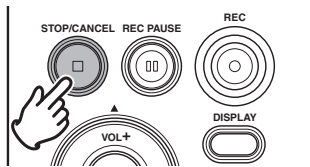

You can press the ►/II/ENTER button to play the just played file, or push the **STOP** button again to enter Stop mode. Then pressing the ►/II/ENTER button will play the beginning of the first audio file.

Note:

The file sort order can be changed using the preset “File Sort”. (☞ P.74)
When set to Alphabet, files are sorted in order of symbol, number, and alphabet. When set to Time/Date, audio files are sorted into the order in which they were created.

Access from File List

There are 2 ways to select the file you want to playback. Either use the ◀◀ or ▶▶ buttons during Stop mode, or select the files from the File List.

1. From Stop, press and hold the **DISPLAY** button for one second.

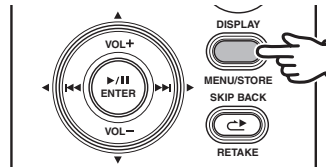

2. Press the ►/II/ENTER button to display the file list.

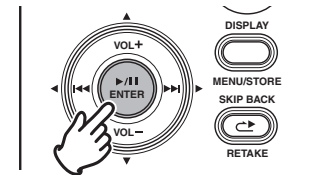

3. Press the **VOL +** or **VOL –** button to select the audio file.



- When the selected file has been recorded with encrypted recording, the correct passcode must be input. (☞ P.33)
- Files recorded with encrypted recording have the extension WAS for WAV files or MPS for MP3 files.
- If an incorrect passcode is input, the file is not played.

4. Press the **VOL +** or **VOL –** button to select “Play”. Then press the **▶/||/ENTER** button to begin playback.

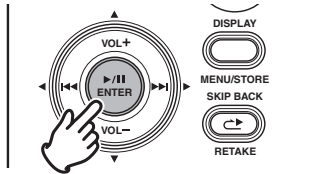

- During playback, press the **STOP/CANCEL** button to return to the File list.

Note:

If the text is small and difficult to see, you can increase the font size using the preset “Font Size”. (☞ P.72)

Search

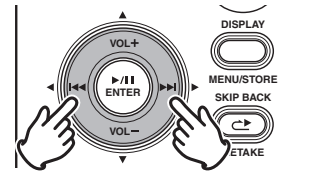

In Play-Pause mode, press and hold the **◀◀** or **▶▶** button for high speed searching without audio. 10X searching speed from beginning to 3 seconds, and 140X speed over 3 seconds until release the button. When you release the button, the recorder returns to playback paused.

If the end of the file is passed with **▶▶** button still held down, search moves to the next file and continues searching in the forward direction.

If the tip of the file is passed with **◀◀** button still held down, search moves to the previous file and continues searching in the reverse direction.

During playback, press and hold the **◀◀** button to “rewind” and do a 2X speed audible search in the reverse direction. During playback, press and hold the **▶▶** button to “fast forward” and do a 2X speed audible search in the forward direction. Release to return to normal forward playback.

Skip Back

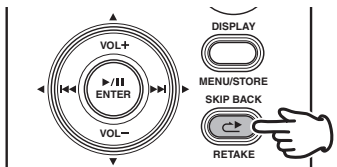

Press the **SKIP BACK** button during playback or pause to return the amount of time set in the preset Skip Back from the current playback point. (☞ P.64)

When this button is pressed during the Rec-Pause mode, the Retake Record mode is set.

Passcode Input

The passcode between 0000 and 9999 that is set at “Passcode” must be input to make the “Menu Lock” and “Passcode” settings on the preset menu and to play files recorded with encrypted recording.

When starting to make these settings or to play such files, the passcode input screen appears on the display and the character selected with the cursor flashes. By factory default, “0000” is displayed.

- 1.** Press the **VOL +** or **VOL –** button to change the character.
 - The number increases between 0 and 9 each time the **VOL +** button is pressed, and decreases between 0 and 9 each time the **VOL –** button is pressed.
 - Press the **◀◀** or **▶▶** button to move the cursor.
- 2.** Either press the **▶/II/ENTER** button or press the **▶▶** button with the cursor set at the last character to enter the passcode.
 - Inputting can be cancelled by pressing the **STOP/CANCEL** button.

Note:

If you have forgotten the passcode, you can change it to “0000” by restoring the PMD620MKII to the factory defaults. (☞ P.79)

Display

Press the **DISPLAY** button to alternate information displays. Displays are slightly different in Stop, Record and Playback mode.

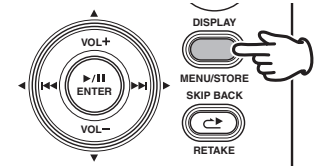

During Stop mode:

① Total Remain



② Current Time/Date



③ Record Setup



① Total Remain (Default display)



- If "Date Form" setting in preset menu is M/D/Y, the date field shows MMMDD/YYYY.
- If "Date Form" setting is D/M/Y, the date field shows DDDMM/YYYY. (P.74)



- The MP3 bitrate is disappeared if the "Rec Format" setting is PCM.
- The ALC icon is disappeared if the "Level Cont." setting is Manual.
- The AUTO TRK icon is disappeared if the "Auto Track" setting is Off.

During Record mode:

① Record Time



② Total Remain Time



③ Record Setup



④ Record Level



① Record Time (Default display)

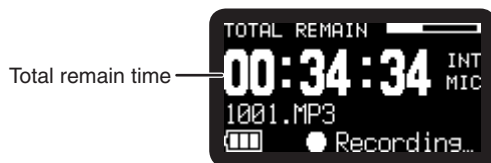

- The MP3 bitrate is disappeared if the "Rec Format" setting is PCM.
- The ALC icon is disappeared if the "Level Cont." setting is Manual.
- The AUTO TRK icon is disappeared if the "Auto Track" setting is Off.

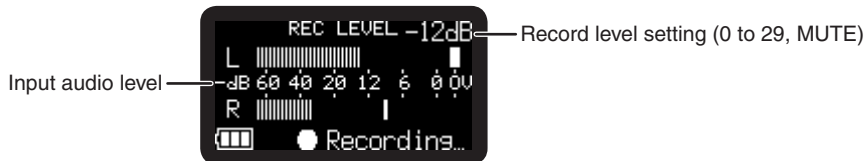

During Playback mode:

① Elapsed Time



② Remain Time



③ File Properties



① Elapsed Time (Default display)

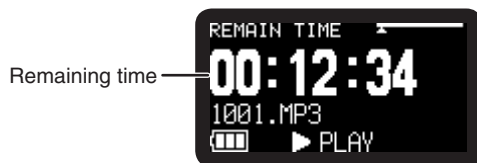

- If "Date Form" setting in preset menu is M/D/Y, the date field shows MMMDD/YYYY. If "Date Form" setting is D/M/Y, the date field shows DDMMM/YYYY. (P.74)

Advanced Features

Microphone(s)

– Attenuator

The microphone attenuation switch permits the direct use of microphones that differ in sensitivity.

- 0dB : No microphone attenuation.
- -12dB: Input from a microphone(s) connected to the MIC jack is cut by 12dB.
- -24dB: Input from a microphone(s) connected to the MIC jack is cut by 24dB.

Setup the “Mic Attenuator” of the preset menu.
( P.62)

– Mic Power

Switch “Mic Power” setting to On to provide +5V of power for a condenser microphone(s).

- On : +5V is supplied to power condenser microphone(s).
- Off : No microphone power is supplied.

Setup the “Mic Power” of the preset menu. ( P.63)

Microphone recommendations

Professional condenser microphone(s) (which require additional power from either the PMD620MKII's phantom power or from another source) are recommended because they provide greater sensitivity and higher quality audio recording.

Dynamic microphone(s) can be used, but they do not yield optimum audio quality recordings in some applications.

Consult with your local dealer to select the appropriate microphone(s) for your specific application. In many cases, they can demonstrate the various performances and characteristics of microphones for your use.

Low Cut Filter

The bass region of the input audio is cut as the audio is recorded. Set to On to reduce noise, such as the sound of the wind when recording outdoors.

Setup the “Low Cut” of the preset menu. (👉 P.63)

Silent Skip

The Silent Skip automatically pauses recording when there is a period of silence and resumes recording when sound resumes.

“Silent Skip” menu setting permits:

- Adjusting the margin sound level that defines silence in Off, -60dB, -54dB, -38dB, -20dB.

Setup the “Silent Skip” of the preset menu. (👉 P.62)

Manual Track

When the Manual Track (Manual Track incrementing) is On during recording, press the **REC** button to increment the audio file.

A new audio file is created at that point. The continuity of sound is not guaranteed and depends on the speed of a card or the audio file size.

Setup the “Manual Track” of the preset menu. (👉 P.61)

Auto Track

With the Auto Track (Automatic Track incrementing) On, a new audio file is begun automatically at specified intervals of recording time. The Auto Track can be set to increment every 1, 5, 10, 15 or 30 minutes, or every 1, 2, 6, 8, 12 or 24 hours. The Auto Track makes finding a particular point in a recording easier. For example, if a new audio file begins every minute during playback, the Auto Track makes finding a particular passage easier because of the relationship between file numbers and time. During playback, you can select file number 3 to play approximately the 3rd minute of recording. To go directly to the beginning of the 10th minute, select file number 10, etc.

#	Recording time minutes:seconds
001.....	0:00 – 1:00
002.....	1:01 – 2:00
003.....	2:01 – 3:00

The continuity of sound is not guaranteed and depends on the speed of a card or the file size.

Setup the “Auto Track” of the preset menu. (👉 P.61)

Note:

New audio file starts automatically when the recorded file size reaches 4GB.

Copy Segment

Copy Segment physically turns your “highlighted” section into a new and separate file, without destroying the original source file(s).

1. During playback, press the **REC** button when the audio reaches your desired In Point.

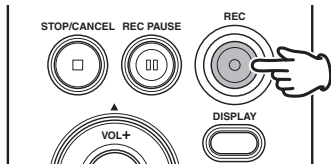

“Set as IN?” is displayed.

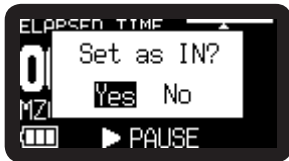

2. Press the **▶/II/ENTER** button to store the In point. “IN-” will flash in the display to indicate the In point has been stored and playback of the file resumes.

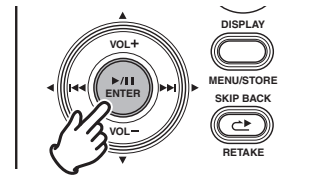

3. Continue to let the PMD620MKII play to your desired Out point, or use the standard transport controls like the **◀◀** or **▶▶** button to span greater time lengths.
4. When you have reached your desired Out point, press the **REC** button.

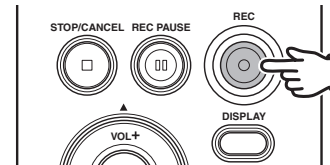

“Set as OUT?” is displayed.

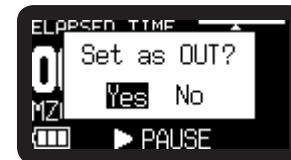

5. Press the ►/||/ENTER button to store the Out point.
“Copy Segment?” is displayed.

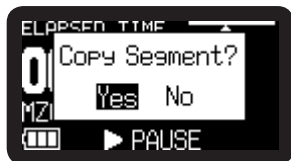

6. Press the ►/||/ENTER button to start the copy process.
“Executing...” will be shown on the display.
When the copy procedure is completed, the display will show
“Completed” for 1 second and then returns to stop mode with
your new file as the current file.

Notes:

- When a copy area spans across two or more files, a file is connected and copied.
- When the copy area spans across files of different “Rec Format” or “Rec Channel” setting, it can not copy.
- The copy area can not exceed 80 minutes.

Key Lock

Slide the **Key Lock** switch to lock the keys.
The key lock secures the PMD620MKII in the state it is in during recording, playback or stop.
During Record and Rec-Pause mode, the **POWER** switch is always invalid.

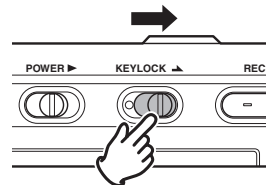

Notes:

- If “Key Lock” setting is All, only the optional remote controller RC600PMD is accepted.
- If “Key Lock” setting is Partial, the **REC**, **REC PAUSE** and **STOP/CANCEL** buttons on the panel, and RC600PMD are accepted.
Setup the “Key Lock” of the preset menu. (☞ P.65)
- “Key Locked” is displayed for 1 second when the key is pressed during key lock.



Remote

The PMD620MKII allows you to use an optional remote controller RC600PMD. (sold separately). The RC600PMD is designed for microphone interviews. It attaches to your microphone. The remote's five feet cord with a four contact mini plug, plugs into the PMD620MKII. The RC600PMD does not require any menu changes for use.

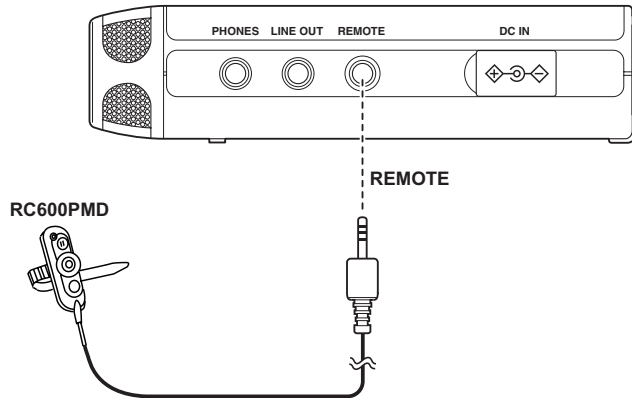

The RC600PMD includes:

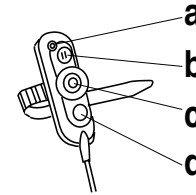

a An indicator light:

- (green) lit and steady during standby or stop
- (red) lit and steady while recording
- (flashing red) during Rec-Pause mode
- (orange) flashes for 1/2 second when an over peak level signal is input during Record or Rec-Pause mode, then it goes back to red.

b push to pause recording

c push to start/resume recording and to manually increment files

d Invalid

Extended Remote Jack

The play, FF, RWD keys can be added to the remote control functions by using the equivalent circuit showing below.

Circuit diagram:

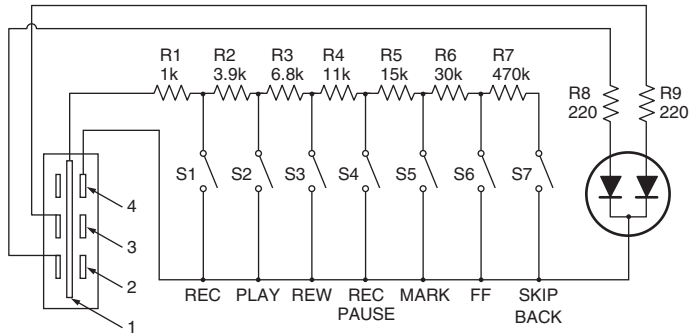

Notes:

- Playback during closing and holding the PLAY switch, and skip back then pause at the point when it opened.
- The MARK switch is invalid for the PMD620MKII.
- Resistance error - Within 5%.
- Never apply external voltage. Doing so will result in malfunction.
- Insulate the circuit so that it cannot be touched directly. Use a structure that protects the circuit from static electricity, which will cause malfunction.
- Do not operate the switches at the same time as the buttons on the set.
- D&M professional accepts no responsibility whatsoever for any damages or infringements of patents or other rights resulting from the use of the circuits. This does not sanction patents or other rights of D&M professional or third parties.
- It is strictly forbidden to reprint or reproduce the circuit diagrams in part or in whole.

Plug Type (1/8" T-R-R-S Mini Plug)

ø3.5/4P (TMP-B66)

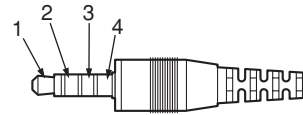

- 1: Tip
- 2: Ring
- 3: Ring
- 4: Sleeve

USB mode

The PMD620MKII records directly onto SD cards. Recordings can then be transferred to your desktop or laptop computer by removing the SD card from the PMD620MKII, or by connecting the PMD620MKII to your computer via the USB port. Audio recorded in the popular MP3 compression format is directly available for intranet or internet file sharing.

Computer compatible

On your computer you can then:

- log and archive audio files
- play audio files
- save audio files to your drive

How to connect via the USB port

The SD card in the PMD620MKII appears as an external drive on a connected computer.

- 1.** Power up the computer.
- 2.** Insert an SD card.
- 3.** Power up the PMD620MKII.
- 4.** During Stop mode, connect the cable to the PMD620MKII and your computer.

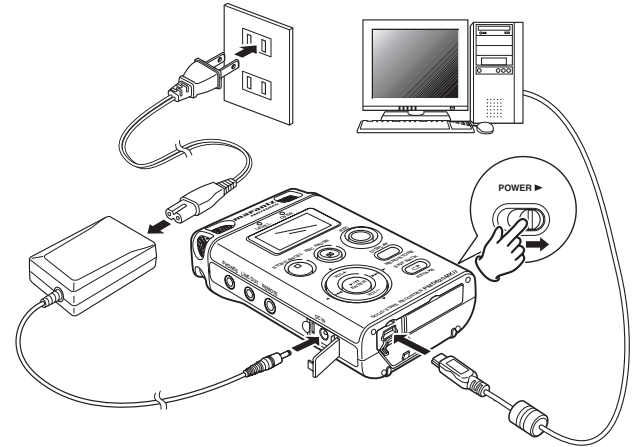

- While USB is on, a set screen is displayed.



- The SD card in the PMD620MKII appears as a removable device on your computer.
- The audio files are in a folder that is named MPGLANG1.

Notes:

- Check the operating system of your computer.
Windows XP, Vista, 7, MAC OS 10
- USB Bus Power activates this function even no service of AC adapter or batteries.
- No buttons other than the **POWER** switch function.

Caution:

- Do not remove a SD card during USB mode. The Data and the SD card may be damaged.
- During recording and playback, do not connect the cable to the PMD620MKII and your computer. The PMD620MKII may turn itself off or stop, by the USB Bus Power condition.

Diagram of file structure

A folder (directory) titled MPGLANG1 will appear on your computer. Files within the MPGLANG1 folder are numbered from aaaaa001 through the number of files recorded to a maximum of aaaaa999. (“aaaaa” depends on the “Machine ID” parameter. The default setting of “Machine ID” is 1) The file extension will be .mp3 or .wav depending on the “Rec Format” parameter that is set for the recording.

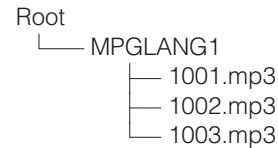

Changes made to file names or structures on your computer will prevent file recognition and playback in the PMD620MKII.

Machine ID

An audio file has Machine ID information. This information is included in a file name. For example, if the Machine ID is “1”, the first file is numbered “1001.wav” or “1001.mp3”. Setup the “Machine ID” of the preset menu. (🔧 P.69)

Menu

Menu Structure

1 File List -----						1 Play
2 Presets -----			Preset 1 -----	1 Select		2 Information
3 Display -----	01 Brightness		Preset 2	2 Edit -----	01 Input	3 Rename
4 Time/Date		02 Font Size	Preset 3	3 Rename	02 Rec Format	4 Delete
5 Utility -----	1 Load Settings	03 LED			03 Rec Channel	
6 Language	2 Save Settings	04 Time Form			04 Sample Rate	
7 F/W Version	3 Card Check	05 Date Form			05 Level Cont.	
	4 Card Format	06 File Sort			06 Level LED	
		07 Default			07 Manual Track	
					08 Auto Track	
					09 Silent Skip	
					10 Mic Atten.	
					11 Low Cut	
					12 Mic Power	
					13 Input Jack	
					14 Skip Back	
					15 Key Lock	
					16 Battery	
					17 Auto Power Off	
					18 Encrypt Rec	
					19 Menu Lock	
					20 Passcode	
					21 SP Mute	
					22 Machine ID	
					23 Preset Default	

Menu List

1. From Stop, press and hold the **DISPLAY** button for one second.

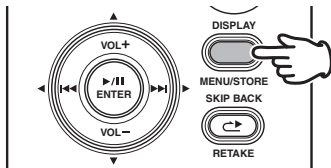

- Menu List appears in the display.
- The selected item is highlighted.
- When the first item is selected, press **VOL +** button to jump to the last item.
- When the last item is selected, press **VOL -** button to jump to the first item.

2. Press the **VOL +** or **VOL -** button to select the item.
3. Press the **▶/||/ENTER** button to confirm or execute the selected item.

Items and functions

#	Display	Description
1	File List	Browse audio files
2	Presets	Go to Preset menu
3	Display	Go to Display menu
4	Time/Date	Adjust current time and date
5	Utility	Go to Utility
6	Language	Select Language
7	F/W version	Display the firmware version

Protecting the Menu Settings

When “Menu Lock” on the preset menu is set to “On”, the passcode is required to select items below the top menu, thereby protecting the settings.

The passcode is the number from 0000 to 9999 set at “Passcode” on the preset menu. (P.33)

File List

File list displays a list of file titles, MP3 and WAV in 'MPGLANG1' folder. The selected file can be played, renamed and deleted. The file information can be displayed.

1. From Stop, press and hold the **DISPLAY** button for one second.
2. Press the **VOL +** or **VOL -** button to select "File List". Then press the **▶/||/ENTER** button to accept.



- File list appears in the display.
- The selected item is highlighted.
- When the first item is selected, press **VOL +** button to jump to the last item.
- When the last item is selected, press **VOL -** button to jump to the first item.

3. Press the **VOL +** or **VOL -** button to select the file you want to access. Then press the **▶/||/ENTER** button to enter the File list Menu.

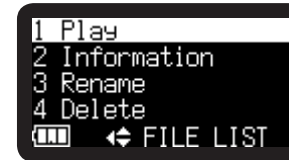

- During File list menu mode, press the **STOP/CANCEL** button to return to Stop mode.
- Press the **I◀◀** button to return to File list.

File list Functions

#	Display	Description
1	Play	Play the file
2	Information	Display information of the file
3	Rename	Rename the file title
4	Delete	Delete the file

Play

1. From Stop, press and hold the **DISPLAY** button for one second.

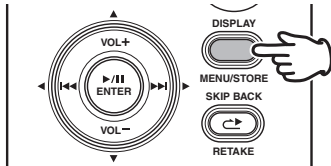

2. Press the **VOL +** or **VOL -** button to select “File List”. Then press the **▶/II/ENTER** button.
 - File list appears in the display.
 - Press the **STOP/CANCEL** button to return to Stop mode.
3. Press the **VOL +** or **VOL -** button to select the file you want to access. Then press the **▶/II/ENTER** button to enter the File list Menu.

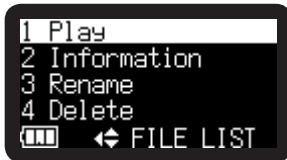

- Press the **I◀◀** button to return to File list.
4. Press the **VOL +** or **VOL -** button to select “Play”. Then press the **▶/II/ENTER** button to start playback.
 - During playback, press the **STOP/CANCEL** button to return to File list.

Information

1. From Stop, press and hold the **DISPLAY** button for one second.

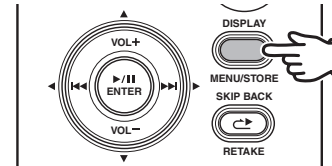

2. Press the **VOL +** or **VOL -** button to select “File List”. Then press the **▶/II/ENTER** button.
 - File list appears in the display.
 - Press the **STOP/CANCEL** button to return to Stop mode.
3. Press the **VOL +** or **VOL -** button to select the file. Then press the **▶/II/ENTER** button to enter the File list Menu.
 - Press the **I◀◀** button to return to File list.
4. Press the **VOL +** or **VOL -** button to select “Information”. Then press the **▶/II/ENTER** button to display the information.
 - Press the **I◀◀** button to return to the File list.
 - Press the **STOP/CANCEL** button to return to Stop mode.

File Rename

1. From Stop, press and hold the **DISPLAY** button for one second.

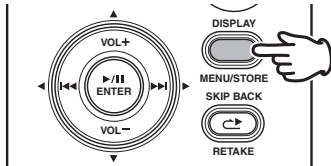

2. Press the **VOL +** or **VOL -** button to select “File List”. Then press the **▶/||/ENTER** button.



- File list appears in the display.
 - Press the **STOP/CANCEL** button to return to Stop mode.
3. Press the **VOL +** or **VOL -** button to select the file. Then press the **▶/||/ENTER** button to enter the File list Menu.
 - Press the **◀◀** button to return to the File list.
 - Press the **STOP/CANCEL** button to return to Stop mode.

4. Press the **VOL +** or **VOL -** button to select “Rename”. Then press the **▶/||/ENTER** button to access the rename window.



5. Rename the file title.

Text can be inserted and deleted. Press the **◀◀** or **▶▶** button to move the cursor to the place you wish to insert text into or delete text from.

To insert text

Press the **VOL +** or **VOL -** button to select the character you want to insert. When the character that you want to insert is displayed, press the **▶/||/ENTER** button to enter the character. The selected character for insertion is highlighted.

To delete text

Press the **SKIP BACK** button to delete the selected character.

6. Press the ►/||/ENTER button to enter the changes.

Notes:

- If there has been a file with the title changed with the ►/||/ENTER button exists, “Exist Title” is displayed for one second.
- If the last letter of the file title is Space(SP) character, the changed title does not include the last letter.
- Extensions are not displayed.
- If number of file title letter is more than 60, last letter is deleted when a new letter is added.
- The characters which you can insert are A B C D E F G H I J K L M N O P Q R S T U V W X Y Z a b c d e f g h i j k l m n o p q r s t u v w x y z (Space) ! “ # \$ % & ’ () + , - . ; = @] ^ _ ` { } ~ 0 1 2 3 4 5 6 7 8 9.

File Delete

- 1.** From Stop, press and hold the **DISPLAY** button for one second.
- 2.** Press the **VOL +** or **VOL –** button to select “File List”. Then press the ►/||/ENTER button.



- File list appears in the display.
 - Press the **STOP/CANCEL** button to return to Stop mode.
- 3.** Press the **VOL +** or **VOL –** button to select the file you want to delete. Then press the ►/||/ENTER button to enter the File list Menu.
 - Press the ◀◀ button to return to the File list.
 - Press the **STOP/CANCEL** button to return to Stop mode.
 - 4.** Press the **VOL +** or **VOL –** button to select “Delete”. Then press the ►/||/ENTER button. “File Delete?” message is displayed.
 - Press the **STOP/CANCEL** button to cancel a File Delete item and return to STOP.
 - 5.** While “File Delete?” message is displayed, select “Yes” and press the ►/||/ENTER button to delete the selected file. During the deletion of file, “Executing...” is displayed. Then “Completed” is displayed for one second.

Utility Menu

The setting data load and save functions and the SD card format and card writing performance can be checked on the “Utility” menu.

1. From Stop, press and hold the **DISPLAY** button for one second.
2. Press the **VOL +** or **VOL –** button to select “Utility Menu”.
3. Press the **▶/||/ENTER** button.



- During Utility menu mode, press the **STOP/CANCEL** button to return to Stop mode.

Utility Functions

#	Display	Description
1	Load Settings	Load setting data from SD card.
2	Save Settings	Save setting data to SD card.
3	Card Check	Check the SD card writing performance.
4	Card Format	Delete all files

Load Settings

Load Settings allows you to load all of the preset value from the SD card in the PMD620MKII.

When performing load settings, use a SD card in which the preset contents from Save Settings are stored.

This function is particularly useful when setting multiple PMD620MKIIs with the same settings.

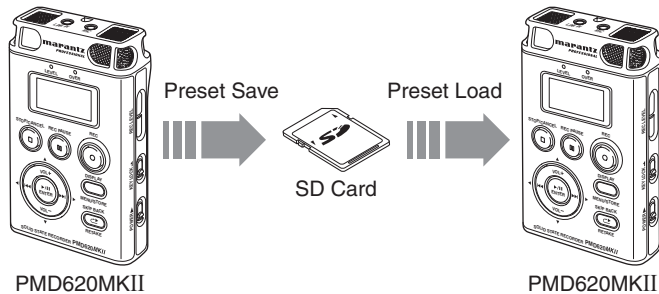

1. From Stop, press and hold the **DISPLAY** button for one second.
2. Press the **VOL +** or **VOL –** button to select “Utility”. Then press the **▶/||/ENTER** button to accept.

3. Press the **VOL +** or **VOL –** button to select “Load Settings”.

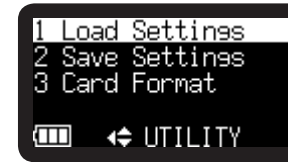

4. Press the **▶/||/ENTER** button. “Load?” message is displayed.
 - Press the **STOP/CANCEL** button to cancel loading items and return to Stop mode.
5. While “Load?” message is displayed, select “Yes” and press the **▶/||/ENTER** button to load the setting value in text format from the file in a route folder on card. The title of the file load is “620preset2.txt”. During load settings, it displays “Executing...”. After the file load is completed, “Completed” is displayed for one second and returns to Stop mode.

Save Settings

Save Settings saves all of the preset values onto the SD card. To set the saved files onto the PMD620MKII, perform Load Settings.

1. From Stop, press and hold the **DISPLAY** button for one second.
2. Press the **VOL +** or **VOL –** button to select “Utility”. Then press the **▶/||/ENTER** button to accept.
3. Press the **VOL +** or **VOL –** button to select “Save Settings”.



4. Press the **▶/||/ENTER** button. “Save?” message is displayed.
 - Press the **STOP/CANCEL** button to cancel saving item and return to Stop mode.
5. While “Save?” message is displayed, select “Yes” and press **▶/||/ENTER** button to output preset value in text format into the file in a route folder on card. The title of the file output is “620preset2.txt”. During preset output, “Executing...” is displayed. After the file output is completed, “Completed” is displayed for one second and returns to Stop mode.

Card Check

The “Card Check” checks the writing performance of the SD card being used and displays the results, as shown below.

Display	Description
Good	Recording is possible without problems.
Poor	Writing problems may occur during recording. It is recommended you use a different SD card.

Notes:

- Do not turn the power off or open the SD card compartment’s lid while the card is being checked. Doing so could damage the card or data. Also, it is recommended you use the AC adapter when checking the card.
- The check results are for reference purposes only; they do not guarantee operation.

Card Format

1. From Stop, press and hold the **DISPLAY** button for one second.
2. Press the **VOL +** or **VOL –** button to select “Utility”. Then press the **▶/||/ENTER** button.
3. Press the **VOL+** or **VOL–** button to select “Card Format”. Then press the **▶/||/ENTER** button.
 - “Card Format?” message is displayed.



- Press the **STOP/CANCEL** button to cancel a Card Format item and return to STOP.
4. While “Card Format?” message is displayed, select “Yes” and press the **▶/||/ENTER** button to format the SD card. During formatting, “Executing..” is displayed. After displaying “Completed” for a second, PMD620MKII return to Stop mode.

File format of the 620preset2.txt

Item	Separator	Set value	Break
[Preset-1]		Fixed value	0D0Ah
Name	=		0D0Ah
Input	=		0D0Ah
:	:	:	:
Auto Power Off	=		0D0A0D0A h
[Preset-2]		Fixed value	0D0Ah
Name			0D0Ah
Input	=		0D0Ah
:	:	:	:
Auto Power Off	=		0D0A0D0A h
[Preset-3]		Fixed value	0D0Ah
Name			0D0Ah
Input	=		0D0Ah
:	:	:	:
Auto Power Off	=		0D0A0D0A h
[Display]		Fixed value	0D0Ah
Brightness			0D0Ah
:	:	:	:
File Sort			0D0A0D0A h
[Common]		Fixed value	0D0Ah
Machine ID	=		0D0Ah
Version	=		0D0Ah

Note:

- The PMD620MKII cannot read an old file, 620preset.cfg.

Preset Menu

You can store up to 3 detailed preset settings such as recording input, recording format, playback mode on the recorder. There are 18 setting items in the preset menu, and 3 presets can be set with the desired conditions.

Preset Select allows you to select a preset number.

1. From Stop, press and hold the **DISPLAY** button for one second.
2. Press the **VOL+** or **VOL -** button to select “Presets”. Then press the **▶/||/ENTER** button.

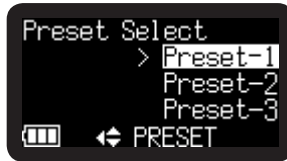

3. Press the **VOL +** or **VOL -** button to select Preset 1, 2, 3 or renamed Preset.

4. Press the **▶/||/ENTER** button to accept the selected Preset.



- Action Menu appears in the display.
- Select “Select” item and press the **▶/||/ENTER** button to store the settings of the selected preset.
- Select “Edit” item and press the **▶/||/ENTER** button to set or change the selected preset.
- Select “Rename” item and press the **▶/||/ENTER** button to change the name of the selected preset.

Action Menu Functions

#	Display	Description
1	Select	Store the selected preset
2	Edit	Set or change the selected preset
3	Rename	Change the title of the selected preset

Preset Rename

1. From Stop, press and hold the **DISPLAY** button for one second.
2. Press the **VOL +** or **VOL –** button to select Preset Menu. Then press the **▶/||/ENTER** button to accept.
3. Press the **VOL +** or **VOL –** button to select Preset 1, 2, 3 or renamed Preset.
Then press the **▶/||/ENTER** button to accept the selected Preset.
4. Press the **VOL +** or **VOL –** button to select “Rename” and press the **▶/||/ENTER** button to accept.



5. Rename the preset title.

Text can be inserted and deleted. Press the **I◀◀** or **▶▶I** button to move the cursor to the place you wish to insert text into or delete text from.

To insert text

Press the **VOL +** or **VOL –** button to select the character you want to insert. When the character that you want to insert is displayed, press the **▶/||/ENTER** button to enter the character. The selected character for insertion is highlighted.

To delete text

Press the **SKIP BACK** button to delete the selected character.

6. Press the **DISPLAY** button to store the changes.

Notes:

- If there has been a preset with the title changed with the **DISPLAY** button exists, “Exist Title” is displayed for one second.
- If the last letter of the preset title is Space(SP) character, the changed title does not include the last letter.
- The maximum length of a preset title is limited to 8 letters. When the 9th letter is inserted, the last letter is deleted.
- The characters which you can insert are A B C D E F G H I J K L M N O P Q R S T U V W X Y Z a b c d e f g h i j k l m n o p q r s t u v w x y z (Space) ! “ # \$ % & ' () + , - . : ; = @] ^ _ ` { } ~ 0 1 2 3 4 5 6 7 8 9.

Table of Preset

Order	Display	Settings	Default		
			Preset 1	Preset 2	Preset 3
1	Input	Auto/ INT MIC/ MIC/ LINE	Auto	Auto	Auto
2	Rec Format	MP3-H/ MP3-M/ MP3-L/ PCM-16/ PCM-24	MP3-M	MP3-H	PCM-24
3	Rec Channel	Stereo/ Mono	Stereo	Stereo	Stereo
4	Sample Rate	44.1k/ 48k	44.1k	44.1k	48k
5	Level Cont.	Manual / ALC	ALC	Manual	Manual
6	Level LED	-54dB/ -38dB/ -20dB/ -12dB/ -6dB	-12dB	-6dB	-6dB
7	Manual Track	On / Off	On	On	On
8	Auto Track	Off/ 1min/ 5min/ 10min/ 15min/ 30min/ 1hour/ 2hour/ 6hour/ 8hour/ 12hour/ 24hour	Off	Off	Off
9	Silent Skip	Off / -60dB / -54dB / -38dB / -20dB	Off	Off	Off
10	Mic Atten.	0dB/ -12dB/ -24dB	0dB	0dB	0dB
11	Low Cut	On/ Off	Off	Off	Off
12	Mic Power	On/ Off	Off	Off	Off
13	Input Jack	Stereo/ Mono	Stereo	Stereo	Stereo
14	Skip Back	0.5sec/ 1sec/ 1.5sec/ 2sec/ 2.5sec/ 3sec/ 3.5sec/ 4sec/ 4.5sec/ 5sec/ 5.5sec/ 6sec/ 6.5sec/ 7sec/ 7.5sec/ 8sec/ 8.5sec/ 9sec/ 9.5sec/ 10sec/ 15sec/ 20sec/ 25sec/ 30sec/ 35sec/ 40sec/ 45sec/ 50sec/ 55sec/ 60sec	3sec	3sec	3sec
15	Key Lock	All/ Partial	All	All	All
16	Battery	Alkaline/ Ni-MH	Alkaline	Alkaline	Alkaline
17	Auto PowerOff	On / Off	On	On	On
18	Encrypt Rec	On / Off	Off	Off	Off
19	Menu Lock	On / Off	Off	Off	Off
20	Passcode	4-digit number	0000	0000	0000
21	SP Mute	On / Off	Off	Off	Off
22	Machine ID	Max 8 letters	1	1	1
23	Preset Default	-	-	-	-

1. Input

Audio input for recording are selected using the Input Menu. If Input of menu is Auto and External MIC is connected, Recording source is External MIC. When LINE jack is connected, Recording source is LINE audio. When the both connected at the same time the External MIC is active as priority.

1. From Stop, press and hold the **DISPLAY** button for one second.
2. Press the **VOL +** or **VOL –** button to select Preset Menu. Then press the **▶/||/ENTER** button to accept.
3. Press the **VOL +** or **VOL –** button to select Preset 1, 2, 3 or renamed Preset. Then press the **▶/||/ENTER** button to accept the selected Preset.
4. Press the **VOL +** or **VOL –** button to select “Edit” and press the **▶/||/ENTER** button to accept.
5. Press the **VOL +** or **VOL –** button to select the Input item. Then press the **I◀◀** or **▶▶I** button to tab through the Input choices (Auto, INT MIC, MIC or LINE).
6. Press the **VOL +** or **VOL –** button to select other Menu choices. When changing the Preset is complete, press the **DISPLAY** button to store the changes, or press the **STOP/CANCEL** button to exit Menu mode without storing any changes.

2. Rec Format

The PMD620MKII can record in several compression algorithms. See explanation and chart below.

MP3-H : MP3 compression with 192kbps (Mono:96kbps)
MP3-M : MP3 compression with 128kbps (Mono:64kbps)
MP3-L : MP3 compression with 64kbps (Mono:32kbps)
PCM-16 : Linear PCM with 16-bit depth
PCM-24 : Linear PCM with 24-bit depth

1. From Stop, press and hold the **DISPLAY** button for one second.
2. Press the **VOL +** or **VOL –** button to select Preset Menu. Then press the **▶/||/ENTER** button to accept.
3. Press the **VOL+** or **VOL–** button to select Preset 1, 2, 3 or renamed Preset. Then press the **▶/||/ENTER** button to accept the selected Preset.
4. Press the **VOL +** or **VOL –** button to select “Edit” and press the **▶/||/ENTER** button to accept.
5. Press the **VOL +** or **VOL –** button to select the Rec Format item. Then press the **I◀◀** or **▶▶I** button to tab through the Rec Format choices (MP3-H, MP3-M, MP3-L, PCM-16 or PCM-24).
6. Press the **VOL +** or **VOL –** button to select other Menu choices. When changing the Preset is complete, press the **DISPLAY** button to store the changes, or press the **STOP/CANCEL** button to exit Menu mode without storing any changes.

3. Rec Channel

The Rec Channel menu choice allows you to select the channel of the audio file.

- 1.** From Stop, press and hold the **DISPLAY** button for one second.
- 2.** Press the **VOL +** or **VOL –** button to select Preset Menu. Then press the **▶/||/ENTER** button to accept.
- 3.** Press the **VOL +** or **VOL –** button to select Preset 1, 2, 3 or renamed Preset. Then press the **▶/||/ENTER** button to accept the selected Preset.
- 4.** Press the **VOL +** or **VOL –** button to select “Edit” and press the **▶/||/ENTER** button to accept.
- 5.** Press the **VOL +** or **VOL –** button to select the Rec Channel item. Then press the **I◀◀** or **▶▶I** button to tab through the Rec Channel choices (Stereo or Mono).
- 6.** Press the **VOL +** or **VOL –** button to select other Menu choices. When changing the Preset is complete, press the **DISPLAY** button to store the changes, or press the **STOP/CANCEL** button to exit Menu mode without storing any changes.

4. Sample Rate

The Sample Rate menu choice allows you to select the sampling rate 44.1kHz or 48kHz.

- 1.** From Stop, press and hold the **DISPLAY** button for one second.
- 2.** Press the **VOL +** or **VOL –** button to select Preset Menu. Then press the **▶/||/ENTER** button to accept.
- 3.** Press the **VOL +** or **VOL –** button to select Preset 1, 2, 3 or renamed Preset. Then press the **▶/||/ENTER** button to accept the selected Preset.
- 4.** Press the **VOL +** or **VOL –** button to select “Edit” and press the **▶/||/ENTER** button to accept.
- 5.** Press the **VOL +** or **VOL –** button to select the Sample Rate item. Then press the **I◀◀** or **▶▶I** button to tab through the Sample Rate choices (44.1kHz or 48kHz).
- 6.** Press the **VOL +** or **VOL –** button to select other Menu choices. When changing the Preset is complete, press the **DISPLAY** button to store the changes, or press the **STOP/CANCEL** button to exit Menu mode without storing any changes.

5. Level Control

The Level Control allows you to select the type of input level control for recording.

1. From Stop, press and hold the **DISPLAY** button for one second.
2. Press the **VOL +** or **VOL –** button to select Preset Menu. Then press the **▶/||/ENTER** button to accept.
3. Press the **VOL +** or **VOL –** button to select Preset 1, 2, 3 or renamed Preset. Then press the **▶/||/ENTER** button to accept the selected Preset.
4. Press the **VOL +** or **VOL –** button to select “Edit” and press the **▶/||/ENTER** button to accept.
5. Press the **VOL +** or **VOL –** button to select the “Level Cont.” item. Then press the **I◀◀** or **▶▶I** button to tab through the “Level Cont.” choices (Manual or ALC).
6. Press the **VOL +** or **VOL –** button to select other Menu choices. When changing the Preset is complete, press the **DISPLAY** button to store the changes, or press the **STOP/CANCEL** button to exit Menu mode without storing any changes.

6. Level LED

When a sound is input during Record or Rec-Pause mode, the LEVEL LED (Green) turns on. A level to turn on is decided in presetting.

1. From Stop, press and hold the **DISPLAY** button for one second.
2. Press the **VOL +** or **VOL –** button to select Preset Menu. Then press the **▶/||/ENTER** button to accept.
3. Press the **VOL +** or **VOL –** button to select Preset 1, 2, 3 or renamed Preset. Then press the **▶/||/ENTER** button to accept the selected Preset.
4. Press the **VOL +** or **VOL –** button to select “Edit” and press the **▶/||/ENTER** button to accept.
5. Press the **VOL +** or **VOL –** button to select the Level LED item. Then press the **I◀◀** or **▶▶I** button to tab through the Level LED choices (–54dB, –38dB, –20dB, –12dB or –6dB)
6. Press the **VOL +** or **VOL –** button to select other Menu choices. When changing the Preset is complete, press the **DISPLAY** button to store the changes, or press the **STOP/CANCEL** button to exit Menu mode without storing any changes.

7. Manual Track

When the Manual Track (Manual Track incrementing) is On during recording, press the **REC** button to increment the audio file.

A new audio file is created at that point.

- 1.** From Stop, press and hold the **DISPLAY** button for one second.
- 2.** Press the **VOL +** or **VOL –** button to select Preset Menu. Then press the **▶/||/ENTER** button to accept.
- 3.** Press the **VOL +** or **VOL –** button to select Preset 1, 2, 3 or renamed Preset. Then press the **▶/||/ENTER** button to accept the selected Preset.
- 4.** Press the **VOL +** or **VOL –** button to select “Edit” and press the **▶/||/ENTER** button to accept.
- 5.** Press the **VOL +** or **VOL –** button to select the Manual Track item. Then press the **I◀◀** or **▶▶I** button to tab through the Manual Track choices (On or Off).
- 6.** Press the **VOL +** or **VOL –** button to select other Menu choices. When changing the Preset is complete, press the **DISPLAY** button to store the changes, or press the **STOP/CANCEL** button to exit Menu mode without storing any changes.

8. Auto Track

With the Auto Track (Automatic Track incrementing) on, a new file begins automatically at specified intervals of recording time.

The Auto Track can be set to increment every 1, 5, 10, 15 or 30 minutes, or every 1, 2, 6, 8, 12 or 24 hours.

- 1.** From Stop, press and hold the **DISPLAY** button for one second.
- 2.** Press the **VOL +** or **VOL –** button to select Preset Menu. Then press the **▶/||/ENTER** button to accept.
- 3.** Press the **VOL +** or **VOL –** button to select Preset 1, 2, 3 or renamed Preset. Then press the **▶/||/ENTER** button to accept the selected Preset.
- 4.** Press the **VOL +** or **VOL –** button to select “Edit” and press the **▶/||/ENTER** button to accept.
- 5.** Press the **VOL +** or **VOL –** button to select the Auto Track item. Then press the **I◀◀** or **▶▶I** button to tab through the Auto Track choices (Off, 1, 5, 10, 15 or 30min, or 1, 2, 6, 8, 12 or 24hours).
- 6.** Press the **VOL +** or **VOL –** button to select other Menu choices. When changing the Preset is complete, press the **DISPLAY** button to store the changes, or press the **STOP/CANCEL** button to exit Menu mode without storing any changes.

9. Silent Skip

The Silent Skip automatically pauses recording when there is a period of silence and resumes recording when sound resumes. This feature is often referred to as voice activated recording. Silent Skip looks for sound below a preset level for three seconds time. When that occurs, the PMD620MKII switches to record pause. When a signal above the preset level is input, recording resumes.

1. From Stop, press and hold the **DISPLAY** button for one second.
2. Press the **VOL +** or **VOL –** button to select Preset Menu. Then press the **▶/||/ENTER** button to accept.
3. Press the **VOL +** or **VOL –** button to select Preset 1, 2, 3 or renamed Preset. Then press the **▶/||/ENTER** button to accept the selected Preset.
4. Press the **VOL +** or **VOL –** button to select “Edit” and press the **▶/||/ENTER** button to accept.
5. Press the **VOL +** or **VOL –** button to select the Silent Skip item. Then press the **◀◀** or **▶▶** button to tab through the Silent Skip choices (Off, –60dB, –54dB, –38dB or –20dB).
6. Press the **VOL +** or **VOL –** button to select other Menu choices. When changing the Preset is complete, press the **DISPLAY** button to store the changes, or press the **STOP/CANCEL** button to exit Menu mode without storing any changes.

10. Mic Attenuator

The Mic Attenuator let you select the direct use of microphone(s) that differ in sensitivity.

1. From Stop, press and hold the **DISPLAY** button for one second.
2. Press the **VOL +** or **VOL –** button to select Preset Menu. Then press the **▶/||/ENTER** button to accept.
3. Press the **VOL +** or **VOL –** button to select Preset 1, 2, 3 or renamed Preset. Then press the **▶/||/ENTER** button to accept the selected Preset.
4. Press the **VOL +** or **VOL –** button to select “Edit” and press the **▶/||/ENTER** button to accept.
5. Press the **VOL +** or **VOL –** button to select the “Mic Atten.” item. Then press the **◀◀** or **▶▶** button to tab through the “Mic Atten.” choices (0dB, –12dB or –24dB).
6. Press the **VOL +** or **VOL –** button to select other Menu choices. When changing the Preset is complete, press the **DISPLAY** button to store the changes, or press the **STOP/CANCEL** button to exit Menu mode without storing any changes.

11. Low Cut

The bass region of the input audio is cut and the audio is recorded. Set to On to reduce noise such as the sound of the wind when recording in outdoor.

- 1.** From Stop, press and hold the **DISPLAY** button for one second.
- 2.** Press the **VOL +** or **VOL –** button to select Preset Menu. Then press the **▶/||/ENTER** button to accept.
- 3.** Press the **VOL +** or **VOL –** button to select Preset 1, 2, 3 or renamed Preset. Then press the **▶/||/ENTER** button to accept the selected Preset.
- 4.** Press the **VOL +** or **VOL –** button to select “Edit” and press the **▶/||/ENTER** button to accept.
- 5.** Press the **VOL +** or **VOL –** button to select the Low Cut item. Then press the **I◀◀** or **▶▶I** button to tab through the Low Cut choices (On or Off).
- 6.** Press the **VOL +** or **VOL –** button to select other Menu choices. When changing the Preset is complete, press the **DISPLAY** button to store the changes, or press the **STOP/CANCEL** button to exit Menu mode without storing any changes.

12. Mic Power

The Mic Power allows you to switch the power on or off so supply to the external condenser microphone from the MIC jack of the PMD620MKII.

- 1.** From Stop, press and hold the **DISPLAY** button for one second.
- 2.** Press the **VOL +** or **VOL –** button to select Preset Menu. Then press the **▶/||/ENTER** button to accept.
- 3.** Press the **VOL +** or **VOL –** button to select Preset 1, 2, 3 or renamed Preset. Then press the **▶/||/ENTER** button to accept the selected Preset.
- 4.** Press the **VOL +** or **VOL –** button to select “Edit” and press the **▶/||/ENTER** button to accept.
- 5.** Press the **VOL +** or **VOL –** button to select the Mic Power item. Then press the **I◀◀** or **▶▶I** button to tab through the Mic Power choices (On or Off).
- 6.** Press the **VOL +** or **VOL –** button to select other Menu choices. When changing the Preset is complete, press the **DISPLAY** button to store the changes, or press the **STOP/CANCEL** button to exit Menu mode without storing any changes.

13. Input Jack

The Input Jack menu choice allows you to select the type of the Input Jack for Stereo or Mono.

- 1.** From Stop, press and hold the **DISPLAY** button for one second.
- 2.** Press the **VOL +** or **VOL –** button to select Preset Menu. Then press the **▶/II/ENTER** button to accept.
- 3.** Press the **VOL +** or **VOL –** button to select Preset 1, 2, 3 or renamed Preset. Then press the **▶/II/ENTER** button to accept the selected Preset.
- 4.** Press the **VOL +** or **VOL –** button to select “Edit” and press the **▶/II/ENTER** button to accept.
- 5.** Press the **VOL +** or **VOL –** button to select the Input Jack item. Then press the **I◀◀** or **▶▶I** button to tab through the Input Jack choices (Stereo or Mono).
- 6.** Press the **VOL +** or **VOL –** button to select other Menu choices. When changing the Preset is complete, press the **DISPLAY** button to store the changes, or press the **STOP/CANCEL** button to exit Menu mode without storing any changes.

14. Skip Back

How to change the Skip Back parameters.

- 1.** From Stop, press and hold the **DISPLAY** button for one second.
- 2.** Press the **VOL +** or **VOL –** button to select Preset Menu. Then press the **▶/II/ENTER** button to accept.
- 3.** Press the **VOL +** or **VOL –** button to select Preset 1, 2, 3 or renamed Preset. Then press the **▶/II/ENTER** button to accept the selected Preset.
- 4.** Press the **VOL +** or **VOL –** button to select “Edit” and press the **▶/II/ENTER** button to accept.
- 5.** Press the **VOL +** or **VOL –** button to select the Skip Back item. Then press the **I◀◀** or **▶▶I** button to tab through the Skip Back choices (0.5 sec to 60 sec)
- 6.** Press the **VOL +** or **VOL –** button to select other Menu choices. When changing the Preset is complete, press the **DISPLAY** button to store the changes, or press the **STOP/CANCEL** button to exit Menu mode without storing any changes.

15. Key Lock

The key lock secures the PMD620MKII in the state it is in during Record, Playback or Stop. If this setting is All, all buttons on PMD620MKII are invalid. If this setting is Partial, the **REC, REC PAUSE** and **STOP/CANCEL** buttons are accepted.

1. From Stop, press and hold the **DISPLAY** button for one second.
2. Press the **VOL +** or **VOL –** button to select Preset Menu. Then press the **▶/||/ENTER** button to accept.
3. Press the **VOL +** or **VOL –** button to select Preset 1, 2, 3 or renamed Preset. Then press the **▶/||/ENTER** button to accept the selected Preset.
4. Press the **VOL +** or **VOL –** button to select “Edit” and press the **▶/||/ENTER** button to accept.
5. Press the **VOL +** or **VOL –** button to select the Key Lock item. Then press the **◀◀** or **▶▶** button to tab through the Key Lock choices (All or Partial).
6. Press the **VOL +** or **VOL –** button to select other Menu choices. When changing the Preset is complete, press the **DISPLAY** button to store the changes, or press the **STOP/CANCEL** button to exit Menu mode without storing any changes.

16. Battery

The PMD620MKII operates on 2 standard AA size Alkaline, or Ni-MH batteries.

1. From Stop, press and hold the **DISPLAY** button for one second.
2. Press the **VOL +** or **VOL –** button to select Preset Menu. Then press the **▶/||/ENTER** button to accept.
3. Press the **VOL +** or **VOL –** button to select Preset 1, 2, 3 or renamed Preset. Then press the **▶/||/ENTER** button to accept the selected Preset.
4. Press the **VOL +** or **VOL –** button to select “Edit” and press the **▶/||/ENTER** button to accept.
5. Press the **VOL +** or **VOL –** button to select the Battery item. Then press the **◀◀** or **▶▶** button to tab through the Battery choices (Alkaline or Ni-MH).
6. Press the **VOL +** or **VOL –** button to select other Menu choices. When changing the Preset is complete, press the **DISPLAY** button to store the changes, or press the **STOP/CANCEL** button to exit Menu mode without storing any changes.

17. Auto Power Off

If the PMD620MKII is not operated for 15 minutes during Stop or Play-Pause mode, the power can be automatically shut off to conserve battery life.

- 1.** From Stop, press and hold the **DISPLAY** button for one second.
- 2.** Press the **VOL +** or **VOL –** button to select Preset Menu. Then press the **▶/||/ENTER** button to accept.
- 3.** Press the **VOL +** or **VOL –** button to select Preset 1, 2, 3 or renamed Preset. Then press the **▶/||/ENTER** button to accept the selected Preset.
- 4.** Press the **VOL +** or **VOL –** button to select “Edit” and press the **▶/||/ENTER** button to accept.
- 5.** Press the **VOL +** or **VOL –** button to select the Auto Power Off item. Then press the **I◀◀** or **▶▶I** button to tab through the Auto Power Off choices (On or Off).
- 6.** Press the **VOL +** or **VOL –** button to select other Menu choices. When changing the Preset is complete, press the **DISPLAY** button to store the changes, or press the **STOP/CANCEL** button to exit Menu mode without storing any changes.

18. Encrypt Rec

The “Encrypt Rec” menu item allows you to set encrypted recording. When the “Encrypt Rec” is turned on, recorded files are encrypted.

- 1.** From Stop, press and hold the **DISPLAY** button for one second.
- 2.** Press the **VOL +** or **VOL –** button to select Preset Menu. Then press the **▶/||/ENTER** button to accept.
- 3.** Press the **VOL +** or **VOL –** button to select Preset 1, 2, 3 or renamed Preset. Then press the **▶/||/ENTER** button to accept the selected Preset.
- 4.** Press the **VOL +** or **VOL –** button to select “Edit” and press the **▶/||/ENTER** button to accept.
- 5.** Press the **VOL +** or **VOL –** button to select the Encrypt Rec item. Then press the **I◀◀** or **▶▶I** button to tab through the Encrypt Rec choices (On or Off).
- 6.** Press the **VOL +** or **VOL –** button to select other Menu choices. When changing the Preset is complete, press the **DISPLAY** button to store the changes, or press the **STOP/CANCEL** button to exit Menu mode without storing any changes.

19. Menu Lock

The “Menu Lock” menu item allows you to protect the setting items below the top menu by password.

- 1.** From Stop, press and hold the **DISPLAY** button for one second.
- 2.** Press the **VOL +** or **VOL –** button to select Preset Menu. Then press the **▶/||/ENTER** button to accept.
- 3.** Press the **VOL +** or **VOL –** button to select Preset 1, 2, 3 or renamed Preset. Then press the **▶/||/ENTER** button to accept the selected Preset.
- 4.** Press the **VOL +** or **VOL –** button to select “Edit” and press the **▶/||/ENTER** button to accept.
- 5.** Press the **VOL +** or **VOL –** button to select the Menu Lock item.
Then press the **◀◀** or **▶▶** button to tab through the Menu Lock choices (On or Off).
- 6.** Press the **VOL +** or **VOL –** button to select other Menu choices. When changing the Preset is complete, press the **DISPLAY** button to store the changes, or press the **STOP/CANCEL** button to exit Menu mode without storing any changes.

20. Passcode

This is the encryption key used for encrypted recording. When the “Menu Lock” is turned on, it is also used as the password.

- 1.** From Stop, press and hold the **DISPLAY** button for one second.
- 2.** Press the **VOL +** or **VOL –** button to select Preset Menu. Then press the **▶/||/ENTER** button to accept.
- 3.** Press the **VOL +** or **VOL –** button to select Preset 1, 2, 3 or renamed Preset. Then press the **▶/||/ENTER** button to accept the selected Preset.
- 4.** Press the **VOL +** or **VOL –** button to select “Edit” and press the **▶/||/ENTER** button to accept.
- 5.** Press the **VOL +** or **VOL –** button to select the Passcode item. Then press the **VOL +** or **VOL –** button to change the character.
 - The number increases between 0 and 9 each time the **VOL +** button is pressed, and decreases between 0 and 9 each time the **VOL –** button is pressed.
 - Press the **◀◀** or **▶▶** button to move the cursor.
- 6.** Either press the **▶/||/ENTER** button or press the **▶▶** button with the cursor set at the last character to enter the passcode.
 - Inputting can be cancelled by pressing the **STOP/CANCEL** button.

7. Press the **VOL +** or **VOL –** button to select other Menu choices. When changing the Preset is complete, press the **DISPLAY** button to store the changes, or press the **STOP/CANCEL** button to exit Menu mode without storing any changes.

Note:

If you have forgotten the passcode, you can change it to “0000” by restoring the PMD620MKII to the factory defaults. (👉 P.79)

21. SP Mute

When “SP Mute” is set to On, the sound being recorded is not output from the speaker. When set to Off, the sound is output from the speaker except when the sound is being recorded by the built-in microphone.

1. From Stop, press and hold the **DISPLAY** button for one second.
2. Press the **VOL +** or **VOL –** button to select Preset Menu. Then press the **▶/||/ENTER** button to accept.
3. Press the **VOL +** or **VOL –** button to select Preset 1, 2, 3 or renamed Preset. Then press the **▶/||/ENTER** button to accept the selected Preset.
4. Press the **VOL +** or **VOL –** button to select “Edit” and press the **▶/||/ENTER** button to accept.
5. Press the **VOL +** or **VOL –** button to select the SP Mute item. Then press the **I◀◀** or **▶▶I** button to tab through the SP Mute choices (On or Off).
6. Press the **VOL +** or **VOL –** button to select other Menu choices. When changing the Preset is complete, press the **DISPLAY** button to store the changes, or press the **STOP/CANCEL** button to exit Menu mode without storing any changes.

22. Machine ID

An audio file has Machine ID information. This information is included in the file name.

For example, if the Machine ID is “aaaaa”, the first file is numbered “aaaaa001.wav” or “aaaaa001.mp3”.

The Machine ID setting applies to all three presets.

1. From Stop, press and hold the **DISPLAY** button for one second.
2. Press the **VOL +** or **VOL –** button to select Preset Menu. Then press the **▶/II/ENTER** button to accept.
3. Press the **VOL +** or **VOL –** button to select Preset 1, 2, 3 or renamed Preset. Then press the **▶/II/ENTER** button to accept the selected Preset.
4. Press the **VOL +** or **VOL –** button to select “Edit” and press the **▶/II/ENTER** button to accept.
5. Press the **VOL +** or **VOL –** button to select the “Machine ID” item. Then press the **▶/II/ENTER** button to rename.
6. Rename the Mechinae ID.

Text can be inserted and deleted. Press the **◀◀** or **▶▶** button to move the cursor to the place you wish to insert text into or delete text from.

To insert text

Press the **VOL +** or **VOL –** button to select the character you want to insert. When the character that you wish to insert is displayed, press the **▶/II/ENTER** button to enter the character. The selected character for insertion is highlighted.

To delete text

Press the **SKIP BACK** button to delete the selected character.

7. Press the **▶/II/ENTER** button to enter the changes. When changing the Preset is complete, press the **DISPLAY** button to store the changes, or press the **STOP/CANCEL** button to exit Menu mode without storing any changes.

Notes:

- If Last letter of the Machine ID is Space(SP) character, the changed ID do not include the last letter.
- If number of letter is more than 8, last letter is deleted when a new letter is added.
- The characters which you can insert are A B C D E F G H I J K L M N O P Q R S T U V W X Y Z a b c d e f g h i j k l m n o p q r s t u v w x y z (Space) ! “ # \$ % & ` () + , - . : = @] ^ _ ` { } ~ 0 1 2 3 4 5 6 7 8 9.

23. Default

Returns the settings of the selected preset number to default. See page 53 for a table of menu defaults.

- 1.** From Stop, press and hold the **DISPLAY** button for one second.
- 2.** Press the **VOL +** or **VOL –** button to select Preset Menu. Then press the **▶/||/ENTER** button to accept.
- 3.** Press the **VOL +** or **VOL –** button to select Preset 1, 2, 3 or renamed Preset. Then press the **▶/||/ENTER** button to accept the selected Preset.
- 4.** Press the **VOL +** or **VOL –** button to select “Edit” and press the **▶/||/ENTER** button to accept.
- 5.** Press the **VOL +** or **VOL –** button to select the Preset Default item. Then press the **▶/||/ENTER** button to initialize.
- 6.** While “Default?” message is displayed, select “Yes” and then press the **▶/||/ENTER** button, then preset value returns to default and to starts writing on non-volatile memory.

Display Menu

You can store presets on the display menu for such settings as brightness, Font size, LED, Time form etc.

1. From Stop, press and hold the **DISPLAY** button for one second.



- Menu list appears in the display.
 - The selected item is highlighted.
 - When the first item is selected, press **VOL +** button to jump to the last item.
 - When the last item is selected, press **VOL –** button to jump to the first item.
2. Press the **VOL +** or **VOL –** button to select “Display”. Then press the **►/||/ENTER** button.
 - The number of a selected item blinks.
 - The choice of the selected item is highlighted.
 - During Display menu mode, press the **STOP/CANCEL** button to return to Stop mode.

3. Press the **VOL +** or **VOL –** button to select an item. Then press the **◀◀** or **▶▶** button to tab through the choices.
4. Press the **VOL +** or **VOL –** button to select other Menu choices. When changing the Display menu is complete, press the **DISPLAY** button to store the changes, or press the **STOP/CANCEL** button to exit Menu mode without storing any changes.

Display Menu Functions

#	Display	Selection items	Default
1	Brightness	1 to 10	5
2	Font Size	Large / Small	Small
3	LED	On / Off	On
4	Time Form	12H / 24H	12H
5	Date Form	M/D/Y / D/M/Y	M/D/Y
6	File Sort	Alphabet / Time/Date	Time/Date
7	Default	–	–

* Factory default of “Date Form” setting for Europe is D/M/Y.

1. Brightness

The Brightness menu choice allows you to adjust the brightness of the OLED (Organic Light-Emitting Diode) display on the PMD620MKII.

- 1.** From Stop, press and hold the **DISPLAY** button for one second.
- 2.** Press the **VOL +** or **VOL –** button to select Display Menu. Then press the **▶/||/ENTER** button to accept.
- 3.** Press the **VOL +** or **VOL –** button to select the Brightness item. Then press the **I◀◀** or **▶▶I** button to tab through the Brightness choices (1, 2, 3, 4, 5, 6, 7, 8, 9 or 10).
- 4.** Press the **VOL +** or **VOL –** button to select other Menu choices. When changing the setting is complete, press the **DISPLAY** button to store the changes, or press the **STOP/CANCEL** button to exit Menu mode without storing any changes.

2. Font Size

You can increase the font size of the text on the file list screen and preset setting screen.

- 1.** From Stop, press and hold the **DISPLAY** button for one second.
- 2.** Press the **VOL +** or **VOL –** button to select Display Menu. Then press the **▶/||/ENTER** button to accept.
- 3.** Press the **VOL +** or **VOL –** button to select the Font Size item. Then press the **I◀◀** or **▶▶I** button to tab through the Font Size choices (Large or Small).
- 4.** Press the **VOL +** or **VOL –** button to select other Menu choices. When changing the setting is complete, press the **DISPLAY** button to store the changes, or press the **STOP/CANCEL** button to exit Menu mode without storing any changes.

3. LED

The LED menu choice allows you to turn off the light of all LEDs.

- 1.** From Stop, press and hold the **DISPLAY** button for one second.
- 2.** Press the **VOL +** or **VOL –** button to select Display Menu. Then press the **▶/II/ENTER** button to accept.
- 3.** Press the **VOL +** or **VOL –** button to select the LED item. Then press the **I◀◀** or **▶▶I** button to tab through the LED choices (On or Off).
- 4.** Press the **VOL +** or **VOL –** button to select other Menu choices. When changing the setting is complete, press the **DISPLAY** button to store the changes, or press the **STOP/CANCEL** button to exit Menu mode without storing any changes.

4. Time Form

The Time Form allows you to select the format of the current time, 12h format with AM/PM (12H) or 24h format (24H).

- 1.** From Stop, press and hold the **DISPLAY** button for one second.
- 2.** Press the **VOL +** or **VOL –** button to select Display Menu. Then press the **▶/II/ENTER** button to accept.
- 3.** Press the **VOL +** or **VOL –** button to select the Time Form item. Then press the **I◀◀** or **▶▶I** button to tab through the Time Form choices (12H or 24H).
- 4.** Press the **VOL +** or **VOL –** button to select other Menu choices. When changing the setting is complete, press the **DISPLAY** button to store the changes, or press the **STOP/CANCEL** button to exit Menu mode without storing any changes.

5. Date Form

The Date form is the date order month/day/year (M/D/Y) or day/month/year (D/M/Y).

- 1.** From Stop, press and hold the **DISPLAY** button for one second.
- 2.** Press the **VOL +** or **VOL –** button to select Display Menu. Then press the **▶/II/ENTER** button to accept.
- 3.** Press the **VOL +** or **VOL –** button to select the Date Form item. Then press the **I◀◀** or **▶▶I** button to tab through the Date Form choices (M/D/Y or D/M/Y).
- 4.** Press the **VOL +** or **VOL –** button to select other Menu choices. When changing the setting is complete, press the **DISPLAY** button to store the changes, or press the **STOP/CANCEL** button to exit Menu mode without storing any changes.

6. File Sort

The File Sort menu choice allows you to select the file order in the list by name (Alphabet) or time (Time/Date).

- 1.** From Stop, press and hold the **DISPLAY** button for one second.
- 2.** Press the **VOL +** or **VOL –** button to select Display Menu. Then press the **▶/II/ENTER** button to accept.
- 3.** Press the **VOL +** or **VOL –** button to select the File Sort item. Then press the **I◀◀** or **▶▶I** button to tab through the File Sort choices (Alphabet or Time/Date).
- 4.** Press the **VOL +** or **VOL –** button to select other Menu choices. When changing the setting is complete, press the **DISPLAY** button to store the changes, or press the **STOP/CANCEL** button to exit Menu mode without storing any changes.

7. Default

Returns the settings of the Display Menu to default.
See the table of Display Menu Functions.

- 1.** From Stop, press and hold the **DISPLAY** button for one second.
- 2.** Press the **VOL +** or **VOL –** button to select Display Menu. Then press the **▶/||/ENTER** button to accept.
- 3.** Press the **VOL +** or **VOL –** button to select the Default item. Then press the **▶/||/ENTER** button to initialize.
- 4.** While “Default?” message is displayed, select “Yes” and then press the **▶/||/ENTER** button, then preset value returns to default and to starts writing on non-volatile memory.

Select Language

The Language menu item allows you to choose a display language (English, French, Spanish, German, Italian and Swedish).

1. From Stop, press and hold the **DISPLAY** button for one second.

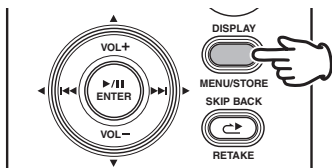

2. Press the **VOL +** or **VOL -** button to select "Language".



3. Press the **▶/||/ENTER** button to enter the Language setting.



- Press the **STOP/CANCEL** button to cancel.
- Press the **VOL +** or **VOL -** button to select the item.
- The display language switches as shown below each time the **VOL +** button is pressed.



- The display language switches as shown below each time the **VOL -** button is pressed.

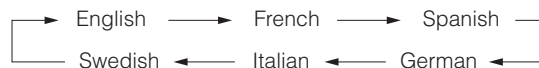

- Press the **◀◀** button to return to the Top Menu.

4. Press the **DISPLAY** button to store the changes.

- Press the **STOP/CANCEL** button to exit Menu mode without storing any changes.

Troubleshooting

Should problems occur, it is often unnecessary to consult your dealer or technical service department. On the basis of the following checks, you may be able to rectify a number of conditions yourself without difficulty. If the condition cannot be remedied after the following check, please consult your dealer or service centers.

Service centers are listed at <http://www.d-mpro.com>.

The PMD620MKII does not turn on.

- Install fresh batteries.
- Check AC adapter connections.

The PMD620MKII turns on then turns itself off.

- Install fresh batteries.

The PMD620MKII seems to record, but there is no sound on playback.

- Check input settings.
(For example, if LINE input is selected and no input is connected to the LINE jack, the PMD620MKII will record silence. The PMD620MKII will not playback.)

There is no audio playback through headphones or internal speaker.

- Check VOL+/- control setting.
- Check a different audio file or the card.

The PMD620MKII will not record.

- Check that the maximum of 999 files have not been recorded.
- Check that the PMD620MKII acknowledges the card.

No signal from microphone input.

- Check input selection.

- Check REC LEVEL control settings.
- Check if microphone(s) require(s) Phantom power.

There is excessive noise on the PMD620MKII.

- Check cable connections and/or replace cable.
- Check for proper gain levels.

Playback on a PC results in poor sound.

- Check quality of PC sound card and program.
 - Check frequency conversion program.*
- * The PMD620MKII records audio files with a sampling frequency of 48kHz. Some PC programs convert the files to 44.1kHz (using a sample rate converter). Only high quality sample rate converters should be used.

PC cannot read files

- Check the capability of the PC program. Some playback and editing programs do not support MP3 or Broadcast Wave (.wav) formats.
- Use DMP Mark Editor to play files recorded with encrypted recording on a computer.

If the PMD620MKII exhibits erratic behavior, the microprocessor can be reset by powering off, disconnecting AC power and removing batteries.

Care and Maintenance

Use a soft cloth slightly moistened with mild detergent solution. Media cards that are heavily used should be occasionally reformatted to avoid audio problems due to fragmentation.

Error Message

Details of error processing

Display	Description
No Card	Card cannot be found
Unformat	Format other than FAT16/32, or card format error
Full Card	Memory is not enough
Full 999	Files are more than 999
No File	No file found
Key Locked	Operation during Key Lock
Card Locked	Prohibition of writing into the card
ALC	REC LEVEL operation during ALC On
VBR	FWD or RWD of VBR file
Can not...	Command is invalid
Need DC IN	No DC input
Low Battery (flashing highlighted)	Remaining battery is below set value
Low Battery	Automatic power down in low battery level last time.
No PresetFile	No preset setting file is found
ErrPresetFile	File contents of preset setting has errors
ErrUpdateFile	Version up file or file system does not function normally
Door Open	CF door is open
Err Format	Error in file format of MP3 or PCM
Exist Title	Same file title is found
Limit 80m	Over 80 minutes in copy segment process
Long Title	File title exceeds 64 Bytes
Err Card	Error is found in the card
Err RTC	Error is found in RTC
Err SRAM	Error is found in SRAM
Err FlashROM	Error is found in Flash ROM
Passcode Fail	Passcode when playing WAS or MPS files is incorrect, or passcode when unlocking the "Menu Lock" is incorrect.

Factory Default

Perform the procedure below to restore the menu settings, passcode, etc., to their factory defaults.

- 1.** Press the **DISPLAY** button and **REC PAUSE** button at the same time, and turn the **POWER** switch ON. At this time, the service menu list is displayed in the display section.
- 2.** Press the **VOL +** or **VOL –** buttons to select “Factory Default?”. At this time, the selected menu item is highlighted.
- 3.** If the **▶/II/ENTER** button is pressed “Default?” is displayed in the display section.
- 4.** While “Default?” is being displayed, press the **I◀◀** button and select “YES”.
- 5.** If the **▶/II/ENTER** button is pressed “Executing ...” flashes in the display section.
 - When the settings have returned to the factory default settings, “Completed” is displayed for 1 second, after which the display section returns to the service menu.
 - When the settings have been returned to the factory default settings, the “Date Form” default setting is the setting for the US. This needs to be set correctly for the destination.
“Date Form”
US : M/D/Y
Europe: D/M/Y
- 6.** Turn the **POWER** switch OFF.

Specifications

Digital Audio System

System.....	Solid State Recorder
Usable media	SD/SDHC cards
Recording format	
MP3.....	MPEG1 LayerIII Compression
WAV	16/24 bit linear PCM
Recording MP3 bit-rate	
Stereo	192/128/64 kbps
Mono.....	96/64/32 kbps
Sample rate	44.1/48 kHz
Number of channels.....	2 (Stereo)/1 (Mono)

Audio Performance

Frequency response	20 Hz - 20 kHz (± 1 dB)
S/N ratio IEC-A weighted	
MIC	68 dB
LINE.....	80 dB
Total harmonic distortion at 0 VU	
MIC	0.06%
LINE	0.02%
Dynamic range.....	81 dB

Inputs

External MIC	
Type	1/8" stereo jack
Input sensitivity	6 mVrms/30 kohms
LINE	
Type	1/8" stereo jack
Input sensitivity	500 mVrms/20 kohms

Outputs

LINE	
Type	1/8" stereo jack
Standard level.....	1.0 V/10 kohms
Headphone	
Type	1/8" stereo jack
Standard level.....	16 mW/16 ohms
Speaker	
Standard level.....	150 mW/8 ohms

General

Power consumption	
Recording/Playback	1.5 W (DC)
Battery life (Alkaline).....	5 hours (Typical)
Phantom power.....	5V, 1mA (Max.)
Environmental conditions	
Operational temperature	0 - 40°C (32 - 104°F)
Operational humidity	25 - 85% (no condensation)
Storage temperature.....	-20 - 60°C (-4 - 140°F)
Dimensions	
Width.....	62 mm (2.5")
Height	102 mm (4")
Depth	25 mm (1")
Weight (Excl. batteries)	110g (4 oz)

Included Accessories

Audio cable
USB cable
AC adapter
User guide
CD-ROM
Handy strap
Tripod/Belt clip adapter
SD card

- Specifications are subject to change without notice.

Limited Warranty

Your Marantz Professional product is warranted against manufacturer defects in material and workmanship for a period of one year parts and labor.

Except as specified below, this warranty covers defects in material and workmanship. The following are not covered under warranty:

1. Damage, deterioration, malfunction or failure to meet performance specifications resulting from:
 - a) Accidents, acts of nature, misuse, abuse, neglect or unauthorized product modification.
 - b) Improper installation, removal or maintenance, or failure to follow supplied instructions.
 - c) Repair or attempted repair by a non-Marantz authorized agent.
 - d) Any shipment (claims must be presented to the carrier).
 - e) Any cause other than a defect of manufacturing.
2. Cleaning, check-ups with no fault found or changes incurred for installation, removal or reinstallation of the product.
3. Any serialized product on which the serial number has been defaced, modified or removed.
4. Batteries and battery chargers.
5. Accessories, including but not limited to: cables, mounting hardware and brackets, cleaning accessories, power cords and adapters, and carry cases.

Non-transferable warranty

This Warranty may be enforced only by the original purchaser.

What We Will Pay For

We will pay for all labor and material expenses for items covered by the warranty.

How You Can Get Service (Americas only)

1. If your unit needs service in the USA, contact our service referral at the appropriate telephone number indicated below. We will advise you of the name and location of one or more authorized service centers from which service may be obtained. Please do not return the unit directly to us.
2. You must pay any shipping charges if it is necessary to ship the product for service. If the necessary repairs are covered by the warranty, we will pay return shipping charges to your location anywhere in the United States or its territories.
3. Whenever warranty service is required, you must present the original dated sales receipt or other proof of date purchased.

Limitation of Implied Warranties

All implied warranties, including warranties of merchantability and fitness for a particular purpose, are limited in duration to the length of this warranty.

Exclusion of Damages (Americas only)

Liability for any defective product is limited to repair or replacement of the product at manufacturer's option. Manufacturer shall not be liable for damage to other products caused by any defects in Marantz products, damages based on inconvenience or loss of use of the product, or any other damages, whether incidental, consequential, or otherwise.

Some States do not allow limitations on how long an implied warranty lasts and/or do not allow the exclusion or limitation of incidental or consequential damages, so the above limitations and exclusions may not apply to you.

How State Law Relates to the Warranty (Americas only)

This warranty gives you specific legal rights, and you may have other rights which may vary from State to State.

Marantz Professional Service Number (Americas only):

Marantz Professional Factory Service (630) 741-0330, toll free within the US (866) 405-2154.

Products purchased outside of the United States, its possessions or territories.

This warranty is enforceable only in the United States and its possessions or territories.

Marantz Professional products Sales Office Site:

For inquiries or information on repair service of Marantz Professional Products, please contact our Sales Office or Tech Support Centre near you which are listed in D&M Professional website below.

AMERICA

D&M Professional America <http://usa.d-mpro.com>

EUROPE

D&M Professional Europe <http://www.dm-pro.eu>

ASIA/OTHERS

D&M Professional Asia <http://apac.d-mpro.com/eng>

D&M Holdings Inc.

TOKYO, JAPAN
www.d-mpro.com

Free Manuals Download Website

<http://myh66.com>

<http://usermanuals.us>

<http://www.somanuals.com>

<http://www.4manuals.cc>

<http://www.manual-lib.com>

<http://www.404manual.com>

<http://www.luxmanual.com>

<http://aubethermostatmanual.com>

Golf course search by state

<http://golfingnear.com>

Email search by domain

<http://emailbydomain.com>

Auto manuals search

<http://auto.somanuals.com>

TV manuals search

<http://tv.somanuals.com>