

Marathon Sensors Inc.

**Oxymit™ Transmitter
Operators Manual**



***Marathon
Sensors Inc.***

F200060

Revision: 00 04/18/2001
01 04/23/2001
02 05/08/2001
03 09/19/2001
04 11/01/2001
05 11/21/2001
06 04/19/2002
07 10/30/2002
08 11/13/2002
09 11/06/2003
10 12/03/2003
11 09/30/2004
12 04/04/2005
13 04/11/2005
14 11/14/2006

COPYRIGHT © 2004
MARATHON SENSORS INC.
3100 East Kemper Road, Cincinnati, Ohio 45241
1-800-547-1055 (513) 772-1000 FAX: (513) 326-7090

All trademarks used in this publication are duly marked and the sole property of their respective owners. No attempt at trademark or copyright infringement is intended or implied.

Marathon Sensors makes no warranties express or implied beyond the written warranty presented at initial purchase. Marathon Sensors Inc. is not responsible for any product, process, damage or injury incurred while using this equipment. Marathon Sensors makes no representations or warranties with respect to the contents hereof and specifically disclaims any warranties of merchantability or fitness for any particular application or purpose.

Table of Contents

GENERAL DESCRIPTION.....	2
SAFETY SUMMARY.....	3
CONNECTIONS.....	3
GROUNDING AND SHIELDING	4
PARAMETER SELECTIONS.....	4
PROCESS PARAMETERS.....	4
<i>Process Type</i>	5
<i>Carbon Process Factor</i>	5
<i>Dew Point Process Factor</i>	5
<i>Oxygen Exponent</i>	6
<i>TC Type</i>	6
ANALOG OUTPUT CHANNELS	6
CALIBRATION.....	7
PROCESS VARIABLE CALCULATIONS.....	8
PERCENT OXYGEN	8
PERCENT CARBON	8
DEWPOINT	8
COMMUNICATIONS.....	9
MODBUS.....	9
<i>RTU Framing</i>	9
<i>Address Field</i>	10
<i>Function Field</i>	10
<i>Data Field</i>	10
<i>Error Check Field (CRC)</i>	10
MEMORY MAP.....	12
OPERATIONAL SPECIFICATIONS.....	18

NOTE:

Please specify the following parameters when ordering a transmitter; process type, process range (% , ppm), thermocouple type, temperature scale F/C, analog output 1 process and scale, analog output 2 process and scale.

**Typical Oxygen Transmitter Calibration
(F840030)**

Calibration Function	Measured Value or Input	Output / Units
Cold Junction	Room Temp	°F
Thermocouple min	800°F (B type) standard t/c type	°F
Thermocouple max	3000°F (B type) standard t/c type	°F
Millivolt	0.0 mV	Millivolts
Millivolt	2000 mV	Millivolts
Analog 1 Zero	0% O ₂	4.0 mA +/- 0.1
Analog 1 Span	20.9% O ₂	20.0 mA +/- 0.1
Analog 2 Zero	800°F +/- 5°	4.0 mA +/- 0.1
Analog 2 Span	3000°F +/- 5°	20.0 mA +/- 0.1

**Typical Carbon Transmitter Calibration
(F840031)**

Calibration Function	Measured Value or Input	Output / Units
Cold Junction	Room Temp	°F
Thermocouple Min	MUST BE SPECIFIED	°F
Thermocouple Max	MUST BE SPECIFIED	°F
Millivolt	0.0 mV	Millivolts
Millivolt	2000 mV	Millivolts
Analog 1 Zero	0% Carbon	4.0 mA +/- 0.1
Analog 1 Span	2.55% Carbon	20.0 mA +/- 0.1
Analog 2 Zero	MUST BE SPECIFIED	4.0 mA +/- 0.1
Analog 2 Span	MUST BE SPECIFIED	20.0 mA +/- 0.1

General Description

The Oxymit™ Transmitter has been designed to work as an analog or digital interface for any zirconia based oxygen probe used to track dew point, carbon potential, or oxygen. The transmitter connects to the temperature and millivolts outputs of an oxygen probe and can produce analog outputs proportional to the selected process value.

The features available are:

- Isolated inputs for thermocouple and probe millivolt
- 24 bit Sigma-Delta ADC for inputs.
- Serial EEPROM to store setup and calibration values.
- Two isolated self-powered 4-20mA outputs for process value and temperature.

The transmitter makes a carbon or oxygen probe an intelligent stand alone sensor. The transmitter is located near the probe, preferably mounted in an enclosure. The transmitter mounts onto a DIN rail and requires a 24VDC power supply. It measures the probe temperature and millivolts. At the time of order the transmitter can be configured to calculate percent carbon, dewpoint, or percent oxygen from these inputs. The results of any of these calculations are made available via two 4-20mA loop outputs. Typically one first loop is set up for the process value the second loop transmits probe temperature.

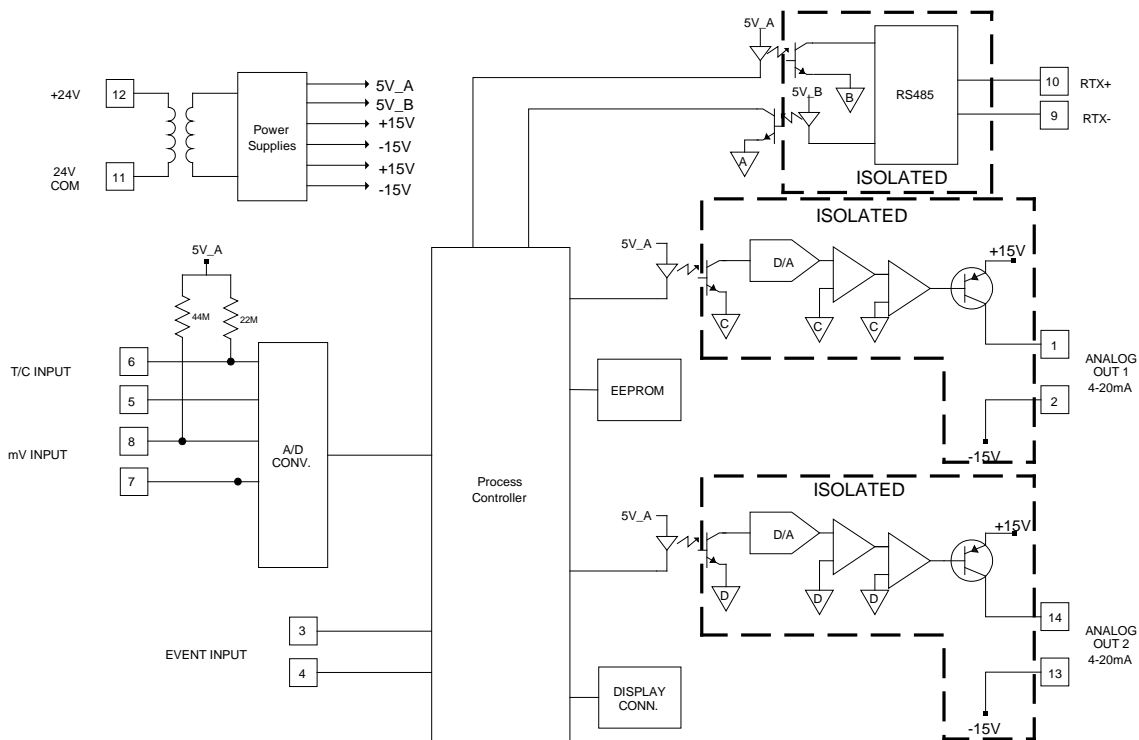

Figure 1 BLOCK DIAGRAM

Safety Summary

All cautions and instructions that appear in this manual must be complied with to prevent personnel injury or damage to the Probe Transmitter or connected equipment. The specified limits of this equipment must not be exceeded. If these limits are exceeded or if this instrument is used in a manner not intended by Marathon Sensors Inc., damage to this instrument or connected devices could occur.

Do not connect this device directly to AC motors, valves, or other actuators. All AC alarm functions must be connected through an interposing DC coil relay with a maximum coil load of 0.5 amps DC. The Probe Transmitter is not rated to act as a safety device. It should not be used to provide interlocking safety functions for any temperature or process functions. Alarm capabilities are provided for probe test and input faults only and are not to be considered or used as safety contacts in any application.

Connections

The Probe Transmitter has four removable terminal blocks grouped with four terminals each. Each terminal is a wire clamp type with a standard slot screw. Each clamp can accommodate AWG 24 to 12 flexible stranded wire. Maximum torque on the terminal screws should not exceed 0.8 Nm.

The figure below shows the arrangement of the terminals.

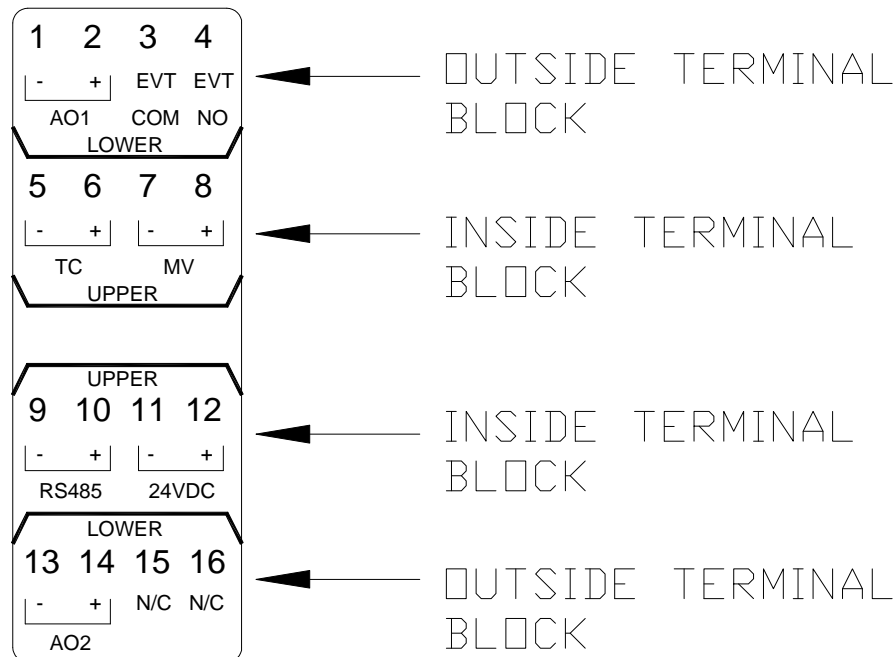

Figure 2 Terminal Layout

The next figure shows a schematic representation of the Probe Transmitter and typical connections required in the field.

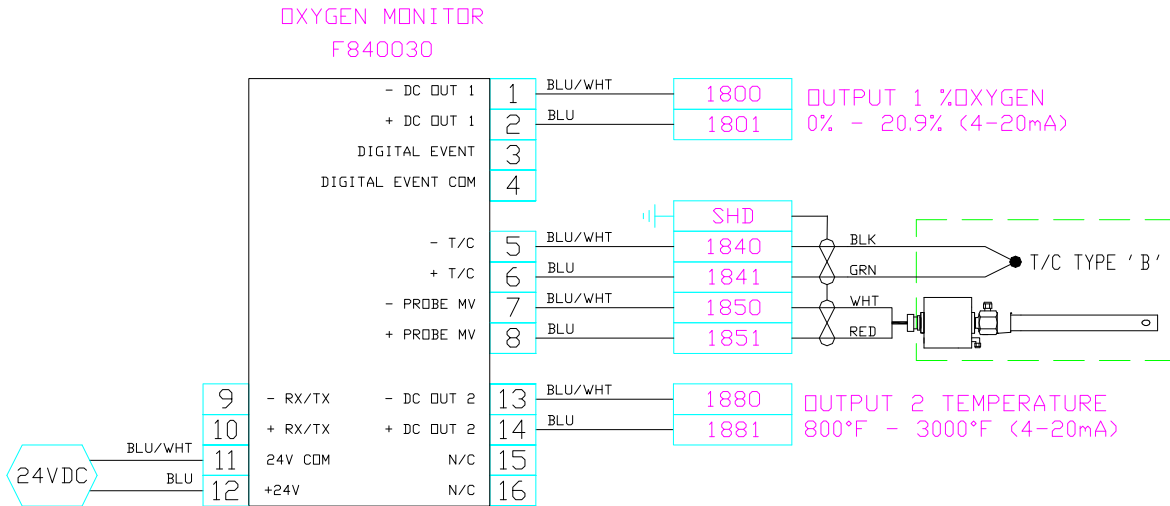

Figure 3 Schematic Connections

Grounding and Shielding

To minimize the pick-up of electrical noise, the low voltage DC connections and the sensor input wiring should be routed away from high-current power cables. Where it is impractical to do this, use shielded cables with the shield grounded at the Probe Transmitter enclosure ground as show above.

Parameter Selections

The following tables list the parameters available in the Probe Transmitter. Default values are also listed. The default values are loaded if a reset is force in the device. Changes to these parameters must be specified at the time of order.

Process Parameters

The following table shows the process selections and other parameters that effect the process value.

Table 1 Process Parameters

Parameter Name	Selection Default	Units or Options	Range
PROCESS TYPE	%O2	CARBON, DPT, %O2, MV	
CARB PROC FACT	150		0 to 1000
DEWPT PROC FACT	150		0 to 1000
OXYGEN EXPON	0002	POWER OF TEN	0 to 31
TC TYPE	B	B, C, E, J, K, N, NNM, R, S, T	

Process Type

Selecting the process type determines what type of calculation the Smart Transmitter is going to do based on the probe millivolt and probe temperature inputs. The default process value for the Smart Transmitter is %O2 with an exponent selection of 2. This is the selection most often used in Boiler control and Combustion applications.

Percent Carbon and dew point are typically processes that are used in steel treating applications. Percent Carbon is the process value most often used for the control of case depth or the percent of carbon in a steel hardening furnace. Dew Point is used in the control for endothermic generators.

Carbon Process Factor

The carbon process factor can be used to adjust the % carbon value. This number takes into account a number of assumptions that the carbon value is based on. Primary among these is the assumed level of CO in the atmosphere. See the Theory of Process Calculation section for a complete explanation of this value.

It maybe necessary to change the apparent furnace carbon as measured by the oxygen probe if this value is different than actual load samples, shim stocks, or gas analysis. The basic rule of thumb is that an increase in the carbon process factor will decrease the apparent carbon level in the furnace. The default value is 150. Typical values can vary from 50 to 400. Increase or decrease the process factor until the desired carbon level is achieved. A process factor that is drastically different than normal may be an indication of a failing probe, water or air leak in the furnace, or excess methane present. Refer to probe troubleshooting guides to determine what other factors maybe effecting the carbon value.

Dew Point Process Factor

The dew point process factor is similar to the carbon process factor but is used to adjust the dew point value if dew point is selected as the process value. This number takes into account a number of assumptions that the dew point value is based on. Primary among these is the assumed level of hydrogen in the atmosphere. See the Theory of Process Calculation section for a complete explanation of this value.

Oxygen Exponent

The range of oxygen is factory configured using the oxygen exponent number. Percent oxygen is the standard setting where the oxygen exponent is set to 2 and the output range is 0.00% to 20.9%. For a part per million (ppm) range the exponent would be set to 6 and the output range of 0.00×10^{-6} to 99.99×10^{-6} .

TC Type

The following table shows the available thermocouple types and the ranges. BOLD indicates the typical oxygen default.

Thermocouple type	Zero °F	Zero °C	Span °F	Span °C
B	800	425	3000	1650
C	32	0	3000	1650
E	32	0	1300	700
J	32	0	1300	700
K	32	0	2300	1260
N	32	0	2300	1260
NNM	32	0	2000	1090
R	300	150	3000	1650
S	300	150	3000	1650
T	32	0	700	370

The Cold Junction correction is applied to all thermocouple types.

Analog Output Channels

The analog outputs are factory configured to provide 4 to 20mA signals proportional to selectable process values.

NOTE

The Analog Output Channels are isolated self-powered current sources and do not require an external supply.

If a chart recorder is to be used, it should have input specifications within 4 to 20 mA. If the recorder only responds to VDC inputs it will be necessary to add a 250 ohm dropping resistor across its input terminals.

The ideal location of the recorder is adjacent to the instrument but it may be located remotely if the connecting wires are properly shielded. For best results, the chart recorder input(s) should be isolated from ground.

Table 2 Analog Outputs

Parameter Name	Oxygen Default	Possible Options	Possible Ranges
OUTPUT 1 MODE	O2 0-20.9% 4-20mA	O2, CARBON, DEWPT, TEMP, LIN, PROG	O2 = 0 – 9999 %C = 0.00 – 2.55 DP = -99.9 – 212.0 Temp = -999 – 3000 LIN = -999 – 9999 PROG = 0 – 4095
OUTPUT 2 MODE	TEMP 800-3000°F 4-20mA	O2, CARBON, DEWPT, TEMP, LIN, PROG	O2 = 0 – 9999 %C = 0.00 – 2.55 DP = -99.9 – 212.0 Temp = -999 – 3000 LIN = -999 – 9999 PROG = 0 – 4095

NOTE: SEE PAGE 4 FOR TYPICAL CALIBRATION VALUES.

Calibration

The Smart Transmitter is factory calibrated. The calibration can be verified once a year or according to customer calibration schedules. The instrument should be returned to the factory if calibration is required.

Process Variable Calculations

The transmitter has a selectable process calculation for percent carbon, percent oxygen, or dewpoint. The following equations are used to derive these values;

Percent Oxygen

$$\%O_2 = \frac{20.95}{e^{(E/0.0215 \cdot Tk)}}$$

Where: E = probe millivolts, Tk = probe temperature in degrees Kelvin.

The 20.95 is the %O₂ in air.

Percent Carbon

$$\%C = 5.102 \frac{e^{((E-786)/(0.043102 \cdot Tk))}}{(29 \cdot PF + 400) + e^{((E-786)/(0.043102 \cdot Tk))}}$$

Where: E = probe millivolts, Tk = probe temperature in Kelvin, and PF is the process factor.

Dewpoint

$$DP = \frac{4238.7}{6.281216 + \log((29 \cdot PF + 400) + (E - 1267.8)/(0.05512 \cdot Tr))} - 459.69$$

Where: E = probe millivolts, Tr = probe temperature in Rankin, PF is the process factor, and DP is the dewpoint in Fahrenheit.

Communications

The Transmitter is capable of digital communications using the Modbus protocol. This is possible by connecting to the half duplex RS-485 terminals using a shielded twisted pair.

Modbus

The MODBUS protocol describes an industrial communications and distributed control system (DCS) that integrates PLCs computers, terminals, and other monitoring, sensing, and control devices. MODBUS is a Master/Slave communications protocol, whereby one device, (the Master), controls all serial activity by selectively polling one or more slave devices. The protocol provides for one master device and up to 247 slave devices on a RS-485 half duplex twisted pair line. Each device is assigned an address to distinguish it from all other connected devices. All instruments are connected in a daisy-chain configuration.

The instrument communicates with baud rate settings 1200, 2400, 4800, 9600, or 19.2K. The default baud rate is 19.2Kbaud. The default address is 1. Changes to these values can be made by writing to the appropriate memory register.

The Transmitter communicates in Modbus RTU (Remote Terminal Unit) protocol using 8-bit binary data characters. Message characters are transmitted in a continuous stream. The message stream is setup based on the following structure:

Number of bits per character:

Start bits	1
Data bits (least significant first)	8
Parity	None only (no bits for no parity)
Stop bits	1
Error Checking	CRC (Cyclical Redundancy Check)

The Transmitter recognizes three RTU commands. These are: read single I registers (command 4), read a single H register (command 3), and preset a single H register (command 6)

In Modbus mode, the Transmitter can be only be configured for the 'none' parity option.

The instrument never initiates communications and is always in receive mode unless responding to a query.

RTU Framing

Frame synchronization can be maintained in RTU transmission mode only by simulating a synchronous message. The instrument monitors the elapsed time between receipt of characters. If three and one-half character times elapse without a new character or completion of the frame, then the instrument flushes the frame and assumes that the next

byte received will be an address. The follow command message structure is used, where T is the required character delay. Response from the instrument is based on the command.

T1,T2,T3	ADDRESS	FUNCTION	DATA	CHECKSUM	T1,T2,T3
	8-BITS	8-BITS	N X 8-BITS	16-BITS	

Address Field

The address field immediately follows the beginning of the frame and consists of 8-bits. These bits indicate the user assigned address of the slave device that is to receive the message sent by the attached master.

Each slave must be assigned a unique address and only the addressed slave will respond to a query that contains its address. When the slave sends a response, the slave address informs the master which slave is communicating.

Function Field

The Function Code field tells the addressed slave what function to perform. MODBUS function codes are specifically designed for interacting with a PLC on the MODBUS industrial communications system. Command codes were established to manipulate PLC registers and coils. As far as the Transmitter is concerned, they are all just memory locations, but the response to each command is consistent with Modbus specifications.

The high order bit in this field is set by the slave device to indicate an exception condition in the response message. If no exceptions exist, the high-order bit is maintained as zero in the response message.

Data Field

The data field contains information needed by the slave to perform the specific function or it contains data collected by the slave in response to a query. This information may be values, address references, or limits. For example, the function code tells the slave to read a holding register, and the data field is needed to indicate which register to start at and how many to read.

Error Check Field (CRC)

This field allows the master and slave devices to check a message for errors in transmission. Sometimes, because of electrical noise or other interference, a message may be changed slightly while it is on its way from one device to another. The error checking assures that the slave or master does not react to messages that have changed during transmission. This increases the safety and the efficiency of the MODBUS system.

The error check field uses a CRC-16 check in the RTU mode.

The following is an example of a function 03 call for data at memory location 03. The value returned by the instrument is the hex value 1E.

Transmit from Host or Master

Address	Cmd	Reg HI	Reg LO	Count HI	Count LO	CRC HI	CRC LO
01	03	00	03	00	01	74	0A

Response from Transmitter

Address	Cmd	Byte Count HI	Byte Count LO	Data HI	Data LO	CRC HI	CRC Lo
01	03	00	02	00	1E	38	4C

Note that all the values are interpreted as hexadecimal values. The CRC calculation is based on the A001 polynomial for RTU Modbus. The function 04 command structure is similar to the 03 structure.

The following is an example of a function 06 call to change data in register 01 to 200. The response from the instrument confirms the new value as being set.

Transmit from Host or Master

Address	Cmd	Reg HI	Reg LO	Data HI	Data LO	CRC HI	CRC LO
01	06	00	01	00	C8	D9	9C

Response from Transmitter

Address	Cmd	Reg HI	Reg LO	Data HI	Data LO	CRC HI	CRC LO
01	06	00	01	00	C8	D9	9C

The Transmitter will respond to several error conditions. The three exception codes that will generate a response from the instrument are:

- 01 – Illegal Function
- 02 - Illegal Data Address
- 03 – Illegal Data Value
- 04 – Slave Device Failure

The response from the Transmitter with an exception code will have the most significant bit of the requested function set followed by the exception code and the high and low CRC bytes.

Memory Map

NOTE: Modbus refers to the hexadecimal register location. These parameters are formatted as unsigned 16 bit integers. Any real number such as temperature can be evaluated as a signed number, other parameters are bit mapped words that must be evaluated as single bits are bit groups.

BLOCK 0				
HEX	DEC	PARAMETER	DESCRIPTION	READ/WRITE
00	0	Not used		READ ONLY
01	1	TIME CONTROL SIOSET	<p>LOW BYTE - TIMER CONTROL BIT 0 – Timer Disabled (0), Timer Enabled (1) BIT 1 – 7 SPARE</p> <p>HIGH BYTE – SIO SETUP BITS 8 – 9 PARITY SETTING 00 = Even Parity, 7 bits, 1 Stop bit 01 = No Parity, 8 bits, 1 Stop bit 10 = Odd Parity, 7 bits, 1 Stop bit</p> <p>BITS 10 – 11 RESPONSE DELAY 0 = No delay applied to response 1 = 10ms delay applied to response 2 = 20ms delay applied to response 3 = 30ms delay applied to response</p> <p>BITS 12 – 14 BAUD SELECT 000 = 76.8K 001 = 38.4K 010 = 19.2K (DEFAULT) 011 = 9600 100 = 4800 101 = 2400 110 = 1200 111 = 600</p> <p>BIT 15 HOST FORMAT 0 = MSI (PROP) 1 = MODBUS (DEFAULT)</p>	READ/WRITE
02	2	TC_ZERO TC_SPAN	<p>LOW BYTE - TC ZERO CALIBRATION NUMBER</p> <p>HIGH BYTE – TC SPAN CALIBRATION NUMBER</p>	READ/WRITE
03	3	MV_ZERO MV_SPAN	<p>LOW BYTE – MV ZERO CALIBRATION NUMBER</p> <p>HIGH BYTE – MV SPAN CALIBRATION NUMBER</p>	READ/WRITE
04	4	PF	PROCESS FACTOR FOR CARBON OR DEWPOINT RANGE = 0 to 4095	READ/WRITE

BLOCK 0				
HEX	DEC	PARAMETER	DESCRIPTION	READ/WRITE
			DEFAULT = 150	
05	5	EVENT LDLN	<p>LOW BYTE – INPUT EVENT CONFIGURATION Bits 0 – 3 0000 = None 0001 = Auto Mode Selected 0010 = Remote Setpoint Selected 0011 = Acknowledge alarms 0100 = Timer Hold 0101 = Timer End 0110 = Timer Start 0111 = Start probe test 1000 = Process hold Bits 4 – 7 not used.</p> <p>UPPER BYTE – LOAD LINE</p>	READ/WRITE
06	6	CJTRM HADR	<p>LOW BYTE – COLD JUNCTION TRIM COLD JUNCTION TRIM (unsigned integer) RANGE = –128 TO +127 WHERE 1 COUNT = 1 DEG (C or F) and –128 = 65408</p> <p>HIGH BYTE – HOST ADDRESS BITS 0-7 RANGE = 0 – 255</p>	
07	7	SPARE	SPARE	
08	8	CONFIG0	<p>Input Configuration</p> <p>BITS 0-3 TC Input TYPE 0000 = B (DEFAULT) 0001 = E 0010 = J 0011 = K 0100 = N 0101 = R 0110 = S 0111 = T 1000 = SPARE 1001 = SPARE 1010 = SPARE 1011 = SPARE 1100 = SPARE 1101 = SPARE 1110 = SPARE 1111 = SPARE BIT 4 = SPARE BIT 5 0 = NO CJ APPLIED, 1 = CJ APPLIED BIT 6 0 = °F, 1 = °C BIT 7 0 = 60HZ FILTER BIT 8 – 11 Millivolt Input TYPE 0000 = LINEAR (DEFAULT) All other bit combinations are spare BITS 12 – 15 are spare</p>	READ/WRITE
09	9	CONFIG2	SETUP VALUES	

BLOCK 0				
HEX	DEC	PARAMETER	DESCRIPTION	READ/WRITE
			BITS 0 - 4 OXYGEN EXPONENT RANGE = 0 to 31, where 2 = % and 6 = ppm DEFAULT = 2 BITS 5 - 6 DISPLAY DECIMAL PLACE where: 0 = no decimal point in display 1 = Display XXX.X 2 = Display XX.XX 3 = Display X.XXX DEFAULT = 0 BITS 8 - 12 REDOX METAL NUMBER RANGE = 0 - 14 DEFAULT = 0 BITS 13 - 15 SPARE	
0A	10	FAULT	FAULT BIT MAP BIT 0 = Temperature Input Open BIT 1 = MV Input Open BIT 2 = Range of input is low BIT 3 = Range of input is high BIT 4 = Timer End BIT 5 = Probe Care Fault BITS 6 - 7 = SPARE BIT 8 = CPU Fault BIT 9 = Min Idle counter = 0 BIT 10 = Keyboard failure, stuck key or a key was pressed during power up. BIT 11 = Flash Erase Failed BIT 12 = Flash Checksum Failed BIT 13 = EEPROM Checksum Failed BIT 14 = Flash/EEPROM Size Fault BIT 15 = ADC Fault	READ ONLY
0B	11	ASRC	ANALOG OUT SOURCES LOW BYTE, ANALOG OUTPUT 1 BITS 0 - 3 0000 = N/A 0001 = Temperature 0010 = Linear Input A 0011 = Carbon value 0100 = Dewpoint value 0101 = Oxygen value 0110 = Redox value 0111 = Output Power 1000 = Control Output 1 1001 = Control Output 2 1010 = Linear Input B 1011 = Programmable* *For Programmable, write required output value into DACV1, where DACV1 = 0 is minimum output and DACV1 = 4096 is maximum output. BITS 4 - 7 SPARE	READ/WRITE

BLOCK 0				
HEX	DEC	PARAMETER	DESCRIPTION	READ/WRITE
			<p>HIGH BYTE, ANALOG OUTPUT 2 BITS 8 – 12 0000 = N/A 0001 = Temperature 0010 = Linear Input A 0011 = Carbon value 0100 = Dewpoint value 0101 = Oxygen value 0110 = Redox value 0111 = Output Power 1000 = Control Output 1 1001 = Control Output 2 1010 = Linear Input B 1011 = Programmable*</p> <p>*For Reference Number and Programmable , write required output value into DACV2, where DACV2 = 0 is minimum output and DACV2 = 4096 is maximum output.</p> <p>BITS 13 – 15 SPARE</p> <p>Special case: If Analog Output 1 = CONTROL OUTPUT 1 and Analog Output 2 = CONTROL OUTPUT 2 and the Control Mode is dual, then Analog Output 1 is 4-20ma for 0 to +100% PO and Analog Output 2 is 4-20ma for 0 to -100% PO.</p>	
0C	12	DAC_OFFSET_1	DAC 1 OFFSET CALIBRATION	READ/WRITE
0D	13	DAC_SPAN_1	DAC 1 SPAN CALIBRATION	READ/WRITE
0E	14	DAC_OFFSET_2	DAC2 OFFSET CALIBRATION	READ/WRITE
0F	15	DAC_SPAN_2	DAC2 SPAN CALIBRATION	READ/WRITE
10	16	AOUTOF1	ANALOG OUTPUT 1 OFFSET Minimum source value that correlates to minimum Analog Output of 4 mA. The source value is based on the selection in ASRC lower byte	READ/WRITE
11	17	AOUTRN1	ANALOG OUTPUT 1 RANGE Maximum source value that correlates to maximum Analog Output of 20 mA. The source value is based on the selection in ASRC lower byte where	READ/WRITE
12	18	AOUTOF2	ANALOG OUTPUT 2 OFFSET Minimum source value that correlates to minimum Analog Output of 4 mA. The source value is based on the selection in ASRC upper byte	READ/WRITE
13	19	AOUTRN2	ANALOG OUTPUT 2 RANGE Maximum source value that correlates to maximum Analog Output of 20 mA. The	READ/WRITE

BLOCK 0				
HEX	DEC	PARAMETER	DESCRIPTION	READ/WRITE
			source value is based on the selection in ASRC upper byte where	
14	20	SPARE	SPARE	READ/WRITE
15	21	SPARE	SPARE	READ/WRITE
16	22	SPARE	SPARE	READ/WRITE
17	23	TEMPFIL	Temperature Input Filter in seconds Range = 0 to 3276. The higher the number the faster the reading update. DEFAULT = 1000	READ/WRITE

BLOCK 1				
HEX	DEC	PARAMETER	DESCRIPTION	READ/WRITE
18	24	MVFIL	Millivolt Input Filter in seconds Range = 0 to 3276. The higher the number the faster the reading update. DEFAULT = 1000	READ/WRITE
19	25	AZERO	LINEAR OFFSET, Y INTERCEPT LINEAR SCALING FOR INPUT A	READ/WRITE
1A	26	ANUM	LINEAR SPAN VALUE FOR INPUT A	READ/WRITE
1B	27	BZERO	LINEAR OFFSET, Y INTERCEPT LINEAR SCALING FOR INPUT B	READ/WRITE
1C	14	BNUM	LINEAR SPAN VALUE FOR INPUT B	READ/WRITE
1D	15	PROC	This value is the calculated process value shown as an integer. The decimal point and exponent values are required to determine the actual scaled value. Range = -999 to 9999. For example: If the process = oxygen, display decimal point = 2, and exponent = 6, and PROC = 1234, then the actual value and displayed as 12.34 ppm.	READ ONLY
1E	16	COLDJCT	COLD JUNCTION Where 1 COUNT = 1°F (°C), RANGE = -99 TO 255°F (°C). Note this parameter is an unsigned integer.	READ ONLY
1F	17	TEMP	MEASURED TEMPERATURE Where temperature is presented in degrees C or F, based on the C/F setting. Note this parameter is an unsigned integer of temperature -2721 = 62815 Range = max / min range of selected thermocouple.	READ ONLY
20	18	MV	MEASURED MILLIVOLT Where this value is scaled in 0.1 mV increments, i.e. 10001 = 1000.1. Range = 0 to 2000 mV.	READ ONLY
21	19	DACV1	ANALOG OUTPUT 1 0 to 4095 is 4 to 20 mA In dual mode 4mA = -100, 12mA = 0, 20mA = +100	READ/WRITE

BLOCK 1				
HEX	DEC	PARAMETER	DESCRIPTION	READ/WRITE
22	20	DACV2	ANALOG OUTPUT 2 0 to 4095 is 4 to 20 ma In dual mode 4mA = -100, 12mA = 0, 20mA = +100	READ/WRITE
23	35	SPARE	SPARE	
24	36	SPARE	SPARE	
25	37	SPARE	SPARE	
26	38	SPARE	SPARE	
27	39	SPARE	SPARE	
28	40	SPARE	SPARE	
29	41	SPARE	SPARE	
2A	42	SPARE	SPARE	
2B	43	SPARE	SPARE	
2C	44	SPARE	SPARE	
2D	45	SPARE	SPARE	
2E	46	SPARE	SPARE	
2F	47	SPARE	SPARE	

Operational Specifications

Power input 21.6 to 26.4 volts DC / 130mA

Thermocouple input

Thermocouple type	Zero °F	Span °F
B	800	3000
C	32	3000
E	32	1300
J	32	1300
K	32	2300
N	32	2300
NNM	32	2000
R	300	3000
S	300	3000
T	32	700

Bold shows default

Accuracy after linearization +/- 1 deg F

Millivolt input -200 to 2000 millivolts +/- 0.1 millivolt

Input Impedance 25 Megohm

Cold junction compensation +/- 1 deg F

DC outputs (Isolated) 0 to 20mA (650Ω max).

Isolation 1000V DC/AC
Power input to signal inputs

Power input to communications

No Isolation Thermocouple input to Millivolt input, inputs must be differential.

Calculations Percent carbon 0 – 2.55%, no CO compensation
Dewpoint -99°F (-72.8°C) – 212 °F (100°C), no hydrogen compensation

Percent oxygen. 0 – 20.9% (default)

CAUTION

DO NOT CONNECT ANY AC SOURCE OR LOAD TO INSTRUMENT CONTACTS

Calibration Setups Millivolt Null
Millivolt Span

Thermocouple Null
Thermocouple Span
Cold Junction Trim

Communications port RS-485 Half Duplex Only

Protocol Modbus RTU
Baud rates 1200, 2400, 4800, 9600, 19.2K (**19.2K default**)
Parity None
Address 1 – 254 (**Address 1 is default**)

Housing

Material Polyamide PA non-reinforced
Inflammability Evaluation Class V0 (UL94)
Temperature Range -40 to 100°C
Dielectric Strength 600 kV/cm (IEC243-1)
Mounting Snaps on to EN 50022 top hat (T) style DIN rail.

Terminals

Wire clamp screw terminals on four position removable terminal blocks.
Wire Size AWG 24 – 12 flexible stranded, removable terminal blocks.
Max. Torque 0.8 Nm

CAUTION: DO NOT CONNECT OR DISCONNECT HOUSING PLUGS WHILE MODULE IS POWERED OR UNDER LOAD.

Weight 10 oz

Environmental Conditions

Operating Temperature -20 °C to 55 °C (-4 to 130 F)
Storage Temperature -40 °C to 85 °C (-40 to 185 F)
Operating and Storage Humidity 85% max relative humidity, noncondensing, from -20 to 65°C

Certifications and Compliance (PENDING)

Safety EN 61010-1, IEC 1010-1
Safety requirement for electrical equipment for measurement, control, and laboratory use, Part 1

Electromagnetic Compatibility
Immunity as specified by EN 50082-2

Electrostatic discharge EN 61000-4-2 Level 3: 8 kV air
Electromagnetic RF fields EN 61000-403 Level 3: 10 V/m
80 MHz – 1 GHz

Fast Transients	EN 61000-4-4	Level 4: 2 kV I/O Level 3: 2 kV power
RF conducted interference	EN 61000-4-6	Level 3: 10 V/rms 150 KHz – 80 MHz
<i>Emissions as specified by EN 50081-2</i>		
RF Interference	EN 55011	Enclosure class A Power main class A

Note: This instrument is designed for installation inside a grounded metal enclosure. Always observe anti-static precautions when installing or servicing any electronic device. Ground your body to discharge any static field before touching the body or terminals of any electronic device.

This specification can change without notification.

Free Manuals Download Website

<http://myh66.com>

<http://usermanuals.us>

<http://www.somanuals.com>

<http://www.4manuals.cc>

<http://www.manual-lib.com>

<http://www.404manual.com>

<http://www.luxmanual.com>

<http://aubethermostatmanual.com>

Golf course search by state

<http://golfingnear.com>

Email search by domain

<http://emailbydomain.com>

Auto manuals search

<http://auto.somanuals.com>

TV manuals search

<http://tv.somanuals.com>