



**Marley**  
 Engineered Products  
 An **SPX** Company

# Environmental Series Air Curtains

INSTALLATION & OPERATING INSTRUCTIONS & PARTS MANUAL

**FOR ALL 120 and 220 VOLT  
 1/4, 1/2 AND 3/4 H.P. MOTOR MODELS**

**READ CAREFULLY BEFORE ATTEMPTING TO ASSEMBLE, INSTALL, OPERATE, OR MAINTAIN THE PRODUCT DESCRIBED. PROTECT YOURSELF AND OTHERS BY OBSERVING ALL SAFETY INFORMATION. FAILURE TO COMPLY WITH INSTRUCTIONS COULD RESULT IN PERSONAL INJURY AND/OR PROPERTY DAMAGE!**

**RETAIN INSTRUCTIONS FOR FUTURE REFERENCE.**

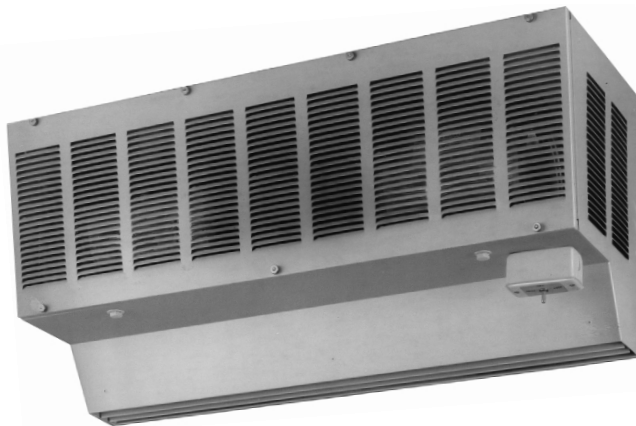

**Figure 1**

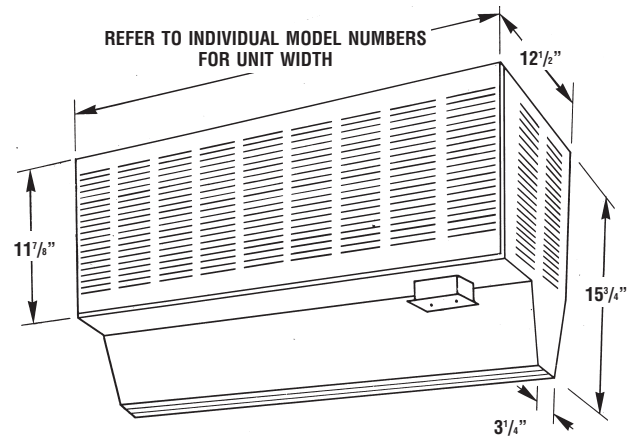

**Figure 2 Dimensions**

### **Description**

Leading Edge air curtains produce a wall of continuously flowing air that acts as a thermal barrier against outside air and flying insects. These air curtains maintain interior conditioned temperature and prevent heated or cooled air from escaping through open doorways. They reduce humidity and loss of cold air when used over freezer and cooler doors. High traffic area doors can be left open, eliminating wear and nuisance of opening and closing automatic and manual doors. Used over service entrances, receiving doors, customer entrances, access doors, etc. ... air curtains provide protection against insects, dust, odor, fumes and other contaminant's.

Note that all dimensions are the same on all environmental series units. Model number indicates width of unit.

(Example: E4800 indicates a 48" wide unit.)

### **Unpacking**

1. With packaged unit on the floor, carton arrows should point upward.
2. Carefully remove staples from top of carton and fold back sides.

### **Specifications and Performance**

HP	MAX. RPM	MAX. MOTOR WATTS	120V, 60HZ MAX. AMPS	220V, 50HZ MAX. AMPS	MAX. FT. PER MIN. AT NOZZLE	AVG. CFM AT NOZZLE FOR MOTOR SHOWN IN VARIOUS CABINET SIZES				
						36"	38"	42"	48"	60" *††
1/4	1100	125	3.4	.7	2500	1620	1670	1795	2000	2880
1/2	1745	480	5.2	2.2	3800	2460	2535	2730	3040	4375
3/4	1700	750	7.8	2.6	4850	3140	3240	3480	3880	5570

†† Two motor unit. \*3/4 HP = 64" Cabinet.

## Unpacking (Continued)

- Carefully remove cabinet from carton by lifting out unit using straps provided.

**CAUTION: Do not attempt to lift this air curtain by its louver or damage may result.**

- Unscrew six (6) knurled nuts and remove air intake grille. (See Figure 3.)

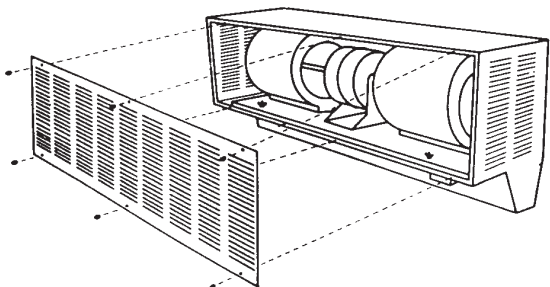

**Figure 3 - Removing Air Intake Grille**

- Carefully disconnect motor electric cord plug assembly and remove two wing nuts on blower base. (See Figure 4.)

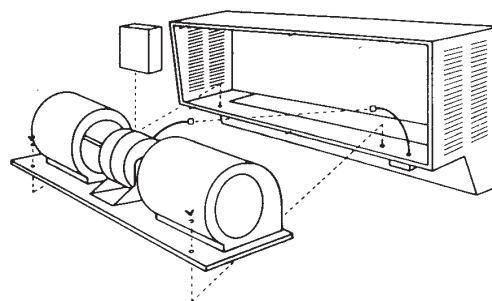

**Figure 4 - Removing Motor/Blower Assembly**

- To remove motor/blower assembly, lift from rear of motor housing to prevent damage and misalignment to shaft and blower wheels.

NOTE: Unit is shipped with styrofoam motor support block which must be discarded at this time.

NOTE: After unpacking unit, inspect carefully for any damage that may have occurred during transit. Check for loose, missing or damaged parts.

## General Safety Information

**WARNING - TO REDUCE THE RISK OF FIRE, ELECTRIC SHOCK, OR INJURY TO PERSONS OBSERVE THE FOLLOWING:**

- Use this unit only in the manner intended by the manufacturer. If you have questions contact the manufacturer.
- Before servicing or cleaning unit, switch power off at service panel and lock service panel to prevent power from being switched on accidentally.
- Installation work and electrical wiring must be done by qualified persons in accordance with all applicable codes and standards, including fire rated construction.
- When cutting or drilling into wall or ceiling, do not damage electrical wiring or other hidden utilities.
- Make certain that the power source conforms to the electrical requirements of the unit. Disconnect power before installing or servicing. If the power disconnect is out of sight, lock it in the open position and tag it to prevent unexpected application of power. Failure to do so could result in fatal electrical shock.

**WARNING: DO NOT DEPEND UPON A THERMOSTAT OR OTHER SWITCH AS THE SOLE MEANS OF DISCONNECTING POWER WHEN INSTALLING OR SERVICING THE UNIT. ALWAYS DISCONNECT POWER AT THE MAIN CIRCUIT BREAKER AS DESCRIBED ABOVE. FAILURE TO DO SO COULD RESULT IN FATAL ELECTRIC SHOCK.**

- All wiring should be done by a qualified electrician, using copper wire only and in accordance with the National Electrical Code (NEC), all applicable code and ordinances, and all sections of this manual. Any variance voids the warranty and may create unsafe conditions.
- Special attention must be given to any grounding information pertaining to this product. To prevent the risk of electrocution, the unit must be securely and adequately grounded. This should be accomplished by connecting a grounded conductor between the service panel and the grounding lug or green lead wire provided in the wiring compartment. To ensure a proper ground, the grounding means must be tested by a qualified electrician.
- Do not insert fingers or foreign objects into the air curtain. Do not block or tamper with it in any manner while it is in operation. Do not touch it while in operation or just after it has been turned off, as some parts may be hot enough to cause injury.
- This product must NOT be used in potentially dangerous locations such as hazardous locations where flammable, explosive, chemical laden, or wet atmospheres are present.
- Do not attach ductwork to this product or attempt to use it as a make-up air heater. Such use voids the warranty and may create unsafe conditions.

**WARNING: TO REDUCE THE RISK OF FIRE OR ELECTRIC SHOCK, DO NOT USE THIS AIR CURTAIN WITH ANY SOLID STATE SPEED CONTROL DEVICE.**

## Installation

1. Using template provided, determine mounting location.
2. Drill holes and attach mounting hardware (not included).

**IMPORTANT: THE HARDWARE AND THE SUPPORTING STRUCTURE MUST BE CAPABLE OF SUPPORTING A MINIMUM 150 LB. LOAD.**

NOTE: All installation should be done to meet local building code.

3. Mount cabinet on wall and securely tighten hardware.
4. Replace motor/blower assembly in cabinet. Secure two wing nuts on blower base. Reconnect motor electric cord plug assembly.
5. Replace intake grille with louvers facing down and refasten knurled nuts.

### ELECTRICAL CONNECTIONS

WARNING: ALL AIR CURTAINS SHOULD BE INSTALLED BY QUALIFIED PERSONNEL.

1. Connect motor per nameplate to correct power supply. Use adequate size wire for all branch and feeder runs.
2. Install all wiring, protection and grounding in accordance with the National Electrical Code (NEC) and all local requirements.

**WARNING: THIS FAN HAS AN INTERNAL SELF RESETTING THERMAL OVERLOAD PROTECTOR. ALWAYS DISCONNECT FROM POWER SUPPLY BEFORE SERVICING.**

3. Remove two screws from switch box and remove cover.

NOTE: Motor is prewired to high/low toggle switch. (See wiring diagram, Figure 5.)

4. Run wires from power supply to switch box using appropriate wiring according to local code. (Use a flexible connector to allow for possible angle adjustment.)
5. Connect wires to the two lead wires provided with wire nuts (not included). Connect black supply to center terminal of rocker switch, white neutral to white (for 220 volt units, L2 will connect to black or white with black tape lead), green grounding lead to grounded conductor of supply circuit. No loose strands or loose connections should be present. After splices are made, wires should be spread apart so that the green and white wires are on one side of outlet box and the black wires are on other side. Turn splices upward and carefully push all wiring into outlet box.
6. Replace switch box cover.
7. Unit is ready for operation.

**CAUTION: Make sure amp rating of any ON/OFF switch exceeds nameplate amp rating of motor.**

8. Restore power.

**NOTE: Air curtain has high/low selector switch. See Operation section for proper setting instructions.**

9. Upon completion of all installation, inspect unit for excessive vibration during operation. If excessive vibration is noticeable, disconnect power supply. Inspect mounting installation and refer to Troubleshooting Chart for probable cause.

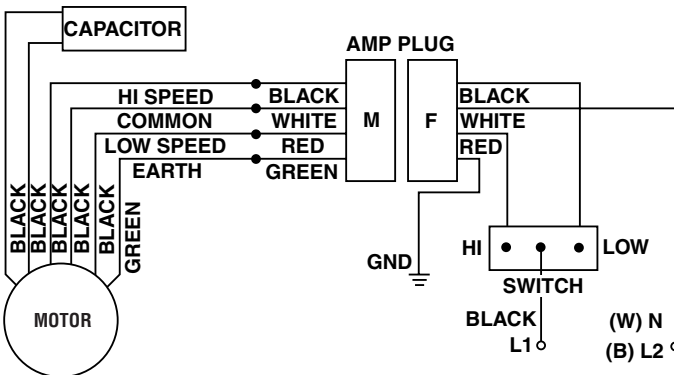

Above for 1/4, 1/2 and 3/4 HP 120 volt motors and  
1/2 and 3/4 HP 220 volt motors.

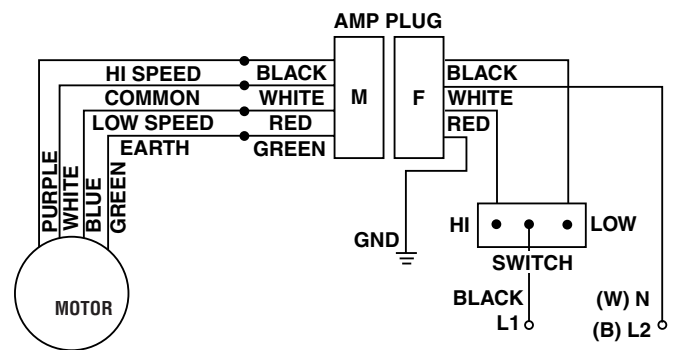

Above for 1/4 HP 220 volt motor.

## Operation

1. After power has been connected to unit, fans will start in either preset (high/low) speed selection.
2. Air velocity is controlled by selection of high or low speed indicator. This feature allows the setting of air velocity to individual desired performance and energy efficiency.
3. Air direction at outlet can be controlled by adjustable vanes at the nozzle which compensates for possible draft conditions.

NOTE: Air direction settings are shown in Figures 6, 7, and 8.

IMPORTANT. IN FREEZER APPLICATIONS, UNIT IS ALWAYS MOUNTED OUTSIDE (WARM SIDE) OF FREEZER OR COOLER.

NOTE: Cold air will try to escape near floor level. Warm air will try to penetrate curtain near top of doorway. Air flow can be controlled by direction of nozzle louvers and by high/low settings.

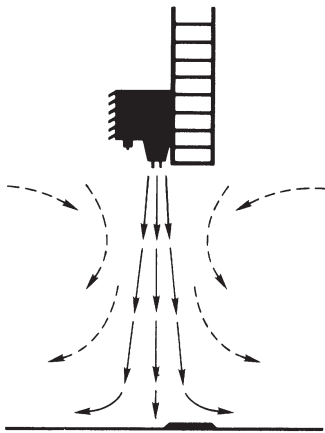

Figure 6 - Desired Air Flow Adjustment for Temperature and Humidity Control.

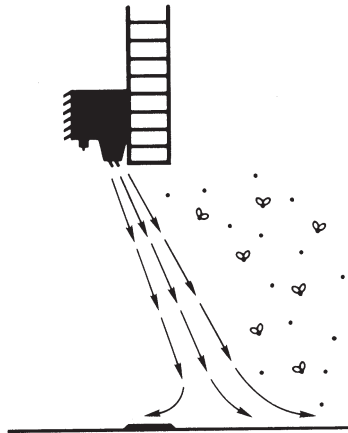

Figure 7 - Desired Air Flow Adjustment for Insect and Dust Control.

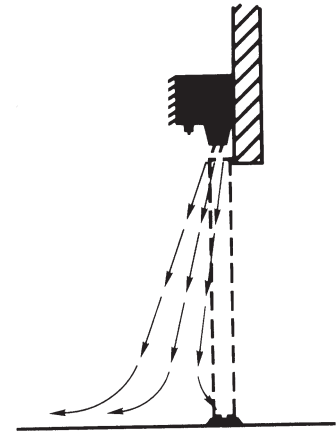

Figure 8 - Desired Air Flow Adjustment for Freezer and Cooler Applications.

## Maintenance

**WARNING: ALWAYS DISCONNECT POWER SUPPLY BEFORE SERVICING.**

### LUBRICATION

Ball bearings are permanently lubricated and require no further lubrication.

### CLEANING

1. The air door cabinet may be wiped off with a damp cloth. Do not allow motor to get wet. Do not use solvents or harsh detergents.

NOTE: Keep air intake louvers clear of dirt and dust accumulation which could affect performance.

2. Check blower wheels for accumulated dirt twice a year and clean. If disassembly is required, see GENERAL SERVICING section.

### GENERAL SERVICING

**WARNING: IF SERVICING IS REQUIRED, IT SHOULD BE DONE BY QUALIFIED PERSONS ONLY.**

**WARNING: ALWAYS DISCONNECT POWER SUPPLY BEFORE SERVICING.**

1. Remove motor/blower assembly. All motor/blower assemblies are designed for easy removal and service with wing nuts and quick disconnect electrical connections.

2. Place motor/blower assembly on workbench.

3. To replace blower wheel, remove the three slotted hex head screws on outer blower ring assembly (See Figure 9, Replacement Parts Illustration.) The wheel is held onto shaft by one hex head screws.

IMPORTANT: NOTE POSITION OF WHEELS TO PREVENT RUBBING WHEN REPLACED.

4. To remove motor:
  - a. Remove blower wheels. (See Step 3 above.)
  - b. Remove blower scroll (six hex head screws).
  - c. Unscrew and remove motor mounts.

5. Replace motor/blower assembly.

## Troubleshooting Chart

SYMPTOM	POSSIBLE CAUSE(S)	CORRECTIVE ACTION
Fan inoperative	<ol style="list-style-type: none"> <li>1. Blown fuse or open circuit breaker.</li> <li>2. Electricity turned off.</li> <li>3. Loose cord connection.</li> <li>4. Defective capacitor or motor.</li> </ol>	<ol style="list-style-type: none"> <li>1. Replace fuse or reset circuit breaker.</li> <li>2. Contact local power company.</li> <li>3. Re-check all connections.</li> <li>4. Replace.</li> </ol>
Excessive noise	<ol style="list-style-type: none"> <li>1. Wheel rubbing on housing.</li> <li>2. Motor base or blower not securely anchored.</li> <li>3. Defective motor bearings.</li> </ol>	<ol style="list-style-type: none"> <li>1. Center wheel.</li> <li>2. Tighten mounting bolts.</li> <li>3. Replace motor.</li> </ol>
Insufficient air flow	<ol style="list-style-type: none"> <li>1. Improper voltage.</li> <li>2. Outlet louvers closed.</li> <li>3. Intakes obstructed.</li> <li>4. Motor speed setting on low.</li> <li>5. Dirty blower wheels</li> </ol>	<ol style="list-style-type: none"> <li>1. Reconnect to proper voltage.</li> <li>2. Open.</li> <li>3. Remove any obstruction.</li> <li>4. Position toggle switch to high.*</li> <li>5. Clean.</li> </ol>
Too much air flow	<ol style="list-style-type: none"> <li>1. Motor speed setting on high.</li> </ol>	<ol style="list-style-type: none"> <li>1. Position toggle switch to low.*</li> </ol>
Fans cut out on thermal overload (self-resets)	<ol style="list-style-type: none"> <li>1. Low voltage.</li> <li>2. Obstruction to blower wheel.</li> </ol>	<ol style="list-style-type: none"> <li>1. Verify correct wire size.</li> <li>2. Remove obstruction.</li> </ol>

\* 120-220 volt models only.

**Replacement Parts  
For Air Curtain Cabinets**

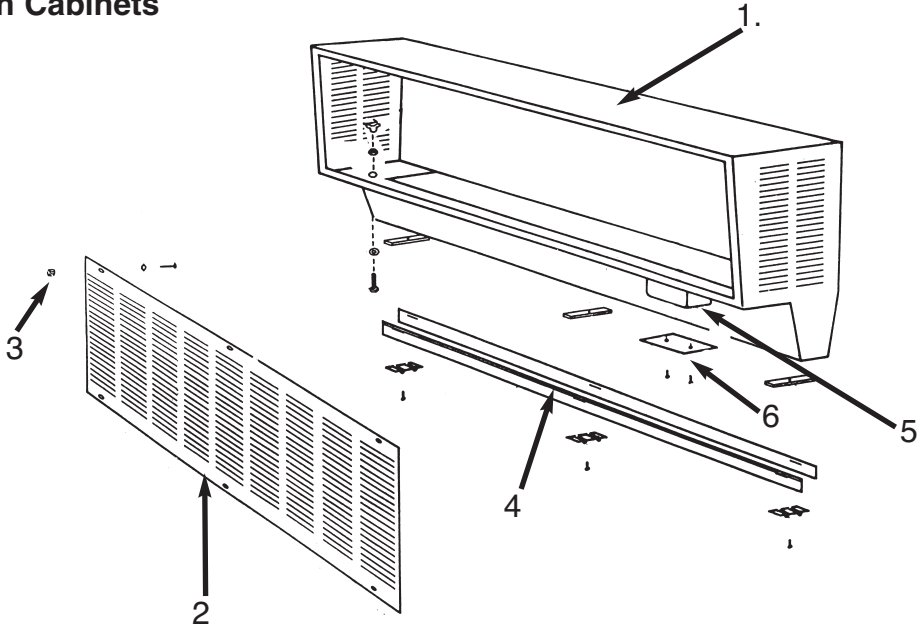

**Figure 9 - Replacement Parts Illustration.**

**Replacement Parts List For Air Curtain Cabinets**

Key No.	Description	Part Numbers for Cabinets (length)				
		36"	38"	42"	48"	60"
1	Cabinet box assembly	ACCA36A	ACCA38A	ACCA42A	ACCA48A	ACCA60A
2	Cabinet Intake Grille	API3685	API3885	API4285	API4885	API6085
3	Cabinet Intake grill knurled nut	AP0002	AP0002	AP0002	AP0002	AP0002
4	Cabinet louver kit	ACL36	ACL38	ACL42	ACL48	ACL60
5	Electric box	ACEB	ACEB	ACEB	ACEB	ACEB
6	Electric box cover	ACFPSPC	ACFPSPC	ACFPSPC	ACFPSPC	ACFPSPC

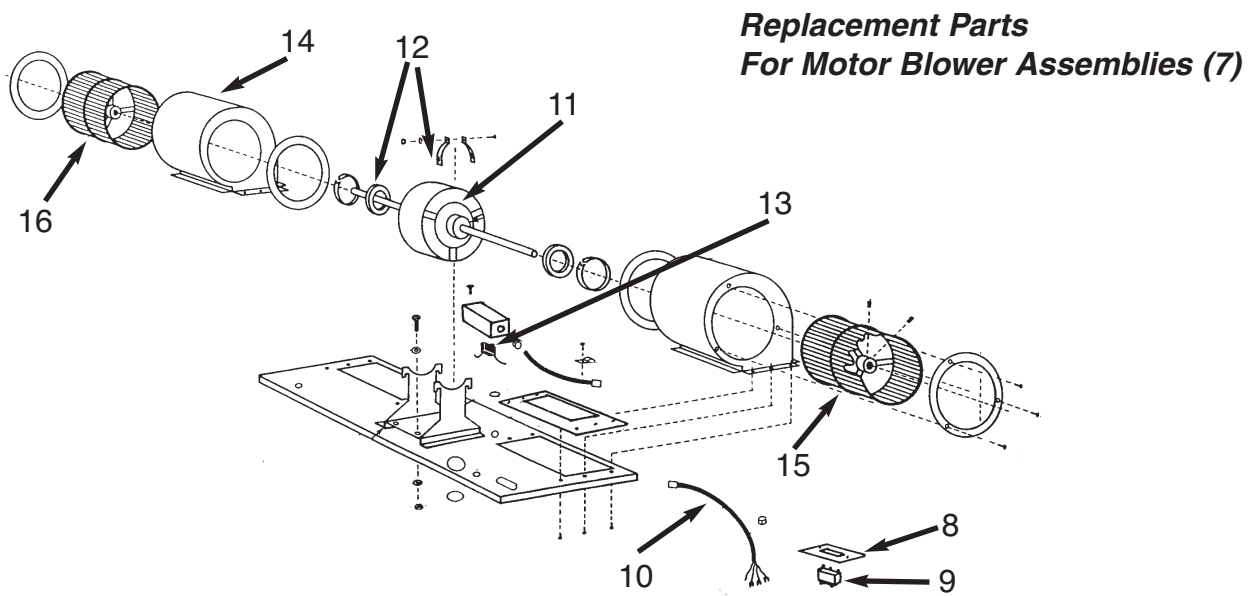

**Figure 9 - Replacement Parts Illustration.**

**Replacement Parts For Air Curtain Cabinets**

Key No.	Description	Part Numbers for Motor Blower Assemblies		
		1/4HP	1/2HP	3/4HP
7	Motor/Blower Assembly			
	120V 1-ph	ACMB125	ACMB150	ACMB175
	220V 1-ph	ACMB225	ACMB250	ACMB275
	208-230/460V 3-ph	ACMB325	ACMB350	ACMB375
8	Switch plate cover	ACFPSH	ACFPSH	ACFPSH
9	Rocker switch	C1220	C1220	C1220
10	Cord, female plug	ACW316	ACW316	ACW316
11	Motor Assembly			
	120V 1-ph	ACM1025	ACM1050	ACM1075
	220V 1-ph	ACM2025	ACM2050	ACM2075
	208-230/460V 3-ph	ACM3025	ACM3050	ACM3075
12	Resilient motor ring kit	AP058	AP058	AP058
13	Capacitor	ACCP1025	ACCP1025	ACCP1075
14	Blower housing	ACBH67	ACBH67	ACBH79
15	Blower wheel-right	ACBW67R	ACBW67R	ACBW79R
16	Blower wheel-left	ACBW67L	ACBW67L	ACBW79L

## LIMITED WARRANTY

All products manufactured by Marley Engineered Products are warranted against defects in workmanship and materials for five years from date of installation. This warranty does not apply to damage from accident, misuse, or alteration; nor where the connected voltage is more than 5% above the nameplate voltage; nor to equipment improperly installed or wired or maintained in violation of the product's installation instructions. All claims for warranty work must be accompanied by proof of the date of installation.

The customer shall be responsible for all costs incurred in the removal or reinstallation of products, including labor costs, and shipping costs incurred to return products to Marley Engineered Products Service Center. Within the limitations of this warranty, inoperative units should be returned to the nearest Marley authorized service center or the Marley Engineered Products Service Center, and we will repair or replace, at our option, at no charge to you with return freight paid by Marley. It is agreed that such repair or replacement is the exclusive remedy available from Marley Engineered Products.

THE ABOVE WARRANTIES ARE IN LIEU OF ALL OTHER WARRANTIES EXPRESSED OR IMPLIED, AND ALL IMPLIED WARRANTIES OF MERCHANTABILITY AND FITNESS FOR A PARTICULAR PURPOSE WHICH EXCEED THE AFORESAID EXPRESSED WARRANTIES ARE HEREBY DISCLAIMED AND EXCLUDED FROM THIS AGREEMENT. MARLEY ENGINEERED PRODUCTS SHALL NOT BE LIABLE FOR CONSEQUENTIAL DAMAGES ARISING WITH RESPECT TO THE PRODUCT, WHETHER BASED UPON NEGLIGENCE, TORT, STRICT LIABILITY, OR CONTRACT.

Some states do not allow the exclusion or limitation of incidental or consequential damages, so the above exclusion or limitation may not apply to you. This warranty gives you specific legal rights, and you may also have other rights which vary from state to state.

For the address of your nearest authorized service center, contact Marley Engineered Products in Bennettsville, SC, at 1-800-642-4328. Merchandise returned to the factory must be accompanied by a return authorization and service identification tag, both available from Marley Engineered Products. When requesting return authorization, include all catalog numbers shown on the products.

### HOW TO ORDER REPAIR PARTS

In order to obtain any needed repair or replacement parts, warranty service or technical information, please contact Marley Engineered Products Service Center toll-free by calling 1-800-642-HEAT.

ECR 35189

03-02

Part No. 5200-2409-001



**Marley**  
Engineered Products

An **SPX** Company  
470 Beauty Spot Rd. East  
Bennettsville, SC 29512 USA



## Free Manuals Download Website

<http://myh66.com>

<http://usermanuals.us>

<http://www.somanuals.com>

<http://www.4manuals.cc>

<http://www.manual-lib.com>

<http://www.404manual.com>

<http://www.luxmanual.com>

<http://aubethermostatmanual.com>

Golf course search by state

<http://golfingnear.com>

Email search by domain

<http://emailbydomain.com>

Auto manuals search

<http://auto.somanuals.com>

TV manuals search

<http://tv.somanuals.com>