



Marvel 8SBAR Beverage Center

Installation
Operation &
Maintenance
Instructions

An AGA Company

INSPECTION

Remove Packaging

Your beverage center has been packed for shipment with all parts that could be damaged by movement securely fastened. Before using, be sure all packing materials and tape have been removed.

Important

Keep your carton packaging until your beverage center has been thoroughly inspected and found to be in good condition. If there is damage, the packaging will be needed as proof of damage in transit.

Note to Customer

This merchandise was carefully packed and thoroughly inspected before leaving our plant. Responsibility for its safe delivery was assumed by the carrier upon acceptance of the shipment. As directed on the side of your packing carton, claims for loss or damage sustained in transit must be made on the carrier as follows:

Exterior Damage

Make thorough damage notation on your delivery receipt and have driver acknowledge by signature and date. Send a written request asking for an inspection report from carrier. Include the name of carrier representative and the date the inspection was requested. Retain inspection report and receipt for filing of a claim.

Concealed Damage

This must be reported to the carrier within fifteen days. Obtain inspection report from the carrier. Retain the inspection report for filing the claim. **DO NOT RETURN DAMAGED MERCHANDISE TO MANUFACTURER - FILE THE CLAIM WITH THE CARRIER.**

INSTALLATION

Select Location

The proper location will ensure peak performance of your appliance. Choose a location where the unit will be out of direct sunlight and away from heat sources. Best performance will be maintained when installed within the following parameters:

Ideal Ambient Temperature Range	
Built-in	65° – 80°F
Free-Standing	65° – 90°F.

Cabinet Clearance

Ventilation is required for the bottom front section of the unit where the grille is located. Keep this area open and clear of any obstructions. Adjacent cabinets and countertop can be installed on top, back and sides of the unit as long as grille and door remain unobstructed. An opening of 30" is required between cabinets with a depth of 24".

Leveling Legs

Make certain that the leveling legs supplied with the unit are installed according to the instructions. Leveling adjustments can be made by raising or lowering the glides on the bottom of the unit.

WARNING
 DISCONNECT POWER SOURCE BEFORE
 ADJUSTING LEVELING LEGS

Electrical Connection

Check the serial nameplate for the correct power supply. Use only the electrical power supply specified on the serial nameplate. Do not use an extension cord.

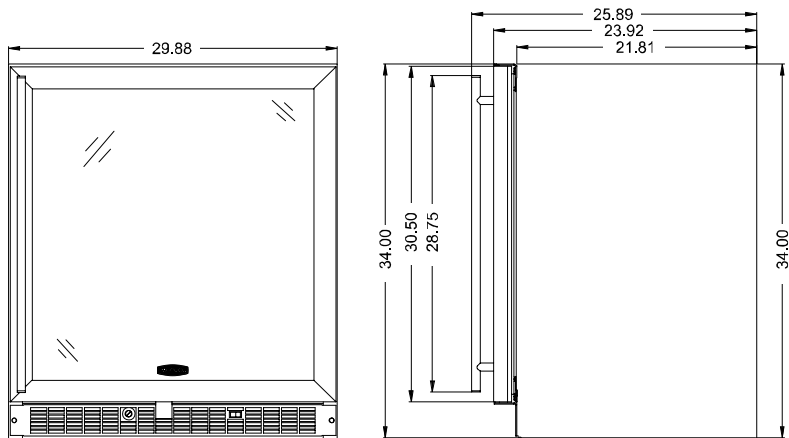
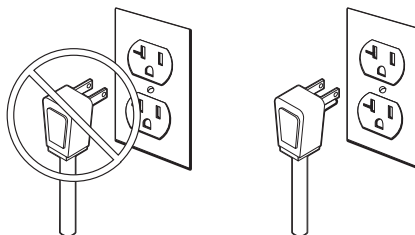

figure 1

Grounding Method

This unit is equipped with a power supply cord with ground. It must be plugged into a mating grounding type receptacle in accordance with the National Electrical Code and applicable local codes and ordinances. It is the customer's responsibility to provide the proper grounding type receptacle. Do not alter the plug in any way.



WARNING
 THIS UNIT SHOULD NOT, UNDER ANY
 CIRCUMSTANCES, BE UNGROUNDED.

All specifications and product design subject to change without notice. Such revisions do not entitle the buyer to corresponding changes, improvements, additions, replacements or compensation for previously purchased products.

HOW TO OPERATE YOUR REFRIGERATED BEVERAGE CENTER

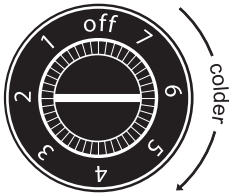

figure 2

Set the Control

The total available temperature range of the unit is from 39°F to the high sixties, depending on the thermostat setting and location of the cabinet. The middle range on the control is from the mid-forties to the mid-fifties depending on ambient temperature and location of the cabinet. The temperature can be lowered or raised by turning the control clockwise or counterclockwise, respectively. As with any refrigeration product, there is a slight temperature variance at different locations within the cabinet. For example, the coolest area will be in the rear of the middle of the cabinet. Commodities on the top shelf will be 3° to 8° warmer. This section and the bottom cabinet step section are the warmest areas. Items in the front of the middle shelves will be 1° to 4° warmer than the rear of the shelves. Position your wine inventory accordingly on your wine shelf.

CAUTION

Do not pull out upper glass shelf when tall bottles are placed upright through the opening in the hinged wire shelf. Doing so may cause the tall, upright bottles to fall backwards.

The glass shelves and fixed position wire rack are for general beverage storage, such as beer and soft drinks. Opened wine bottles and tall beverage containers may be stored on the glass shelf closest to the cabinet top. Just lift the hinged section of the fixed position upper wire rack to provide clearance for the bottles and/or containers to stand upright.

To start your appliance, use a screwdriver to turn the control clockwise to the middle thermostat setting (see figure 2). Once the beverage center is loaded, allow at least 48 hours for the unit to stabilize before making any adjustments to the initial setting.

Insert Wine Bottles

The wine rack roll-out shelf holds eight bottles. See figure 3 for typical wine bottle orientation.

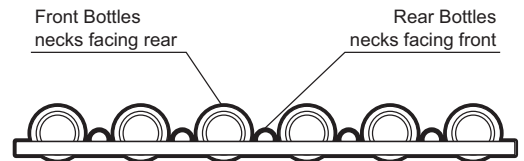

figure 3

Wine rack can be located at the middle or bottom part of the cabinet interior. For red wines, place wine shelf at bottom shelf position in the cabinet. Then put a glass shelf in the next higher position. For white and sparkling wines, put the wine shelf on the middle shelf position in the cabinet. Place the remaining shelves as desired. Also, there is a fixed, wooden, bottle cradle in the bottom, step section of the cabinet. Six bottles of wine may be stored there.

CLEANING AND MAINTAINING

Condenser

The condenser tubing inside the cabinet does not require frequent cleaning; however, satisfactory cooling depends on adequate ventilation over the coils. Be sure that nothing obstructs the required air flow openings in front of the cabinet. At least once or twice a year brush or vacuum lint and dirt from the condenser for efficient performance by unscrewing the grille on the bottom front of the cabinet.

Cabinet

The painted cabinet can be washed with mild soap and water and thoroughly rinsed with clear water. Never use abrasive scouring powders.

Interior

Wash interior compartment with mild soap and water. Do not use an abrasive powder, solvent, polish cleaner or undiluted detergent.

Glass Door

Use a glass cleaner or mild soap and water and soft cloth to clean the glass door model. Do not use any abrasive powders.

Door Gasket

The vinyl gasket may be cleaned with mild soap and water, a baking soda solution or a mild scouring powder.

Light Tube Replacement

WARNING! DISCONNECT THE POWER CORD BEFORE ATTEMPTING LIGHT TUBE REPLACEMENT. Failure to do so may result in an electrical shock that could severely injure you.

This product uses two, 6 watt light tubes to illuminate the interior of the unit. The light tubes are very reliable electrical components, but should either or both light tubes not function properly, please call the dealer you purchased your unit from for replacement light tubes. Use only original equipment light tubes from your dealer or manufacturer.

Light tube replacement consists of using a small phillips head screwdriver to remove the two screws that hold a cover plate over the back section of the light tube. Set the screws and cover plate aside for re-assembly later.

Using a small flat-blade screwdriver, gently lever the front section of the light tube down to allow it to be pulled clear of the light housing.

Disconnect the two insulated electrical connectors from the cabinet's electrical cable and discard the old light tube. Reconnect the insulated electrical connector of the new light tube to the cabinet's electrical cable connectors. Make sure they are secure and fully inserted.

Carefully realign the light tube's electrical terminals back into the rear of the light enclosure channel making sure not to crimp them. Gently insert the light tube along the length of the light enclosure channel. Press the light tube gently into the light enclosure channel. Only a small part of the light tube should project below the ceiling of the unit. **DO NOT USE A HAMMER TO FIT THE LIGHT TUBE.**

Place the light tube terminal cover plate back in its original position on the light enclosure's flange. Re-use the original two screws to secure it in place. Plug the unit into the electrical socket. Check to see if the light tubes operate properly. Your light tube's replacement is complete.

The light tubes are not covered by your guarantee. Replacement tubes can be obtained from your service provider or from Marvel Industries.

FEATURES

Adjustable Temperature Control

Please see "How to Operate Your Refrigerated Beverage Center" on page two.

Interior Light and Switch

The interior light makes it easy to view the contents of your beverage center. When the switch is in the "OFF" position, the light will come on when the door is opened. When the switch is pushed such that the "red" portion of the rocker is showing, the switch is in the "on" position and the interior light will stay on continuously. Remember to turn the off the light when it is no longer needed.



Roll-out Shelves

The roll-out shelves may be pulled out approximately 14 inches to facilitate product loading and retrieval. Do not lean on or press down heavily on the shelves, doing so may damage the shelves or their content. Pull out shelves gently to minimize any possible item shifting. To maintain stability, avoid pulling out more than one shelf at any time.

The roll-out shelves are equipped with a removable center section that allows you to customize the storage capability of your beverage center. Your unit is shipped with two glass shelves, one wine rack, one wooden bottle cradle, and one fixed wire shelf. For added versatility, additional center sections are available. Please contact dealer or see Marvel's website at www.marvelindustries.com for ordering.

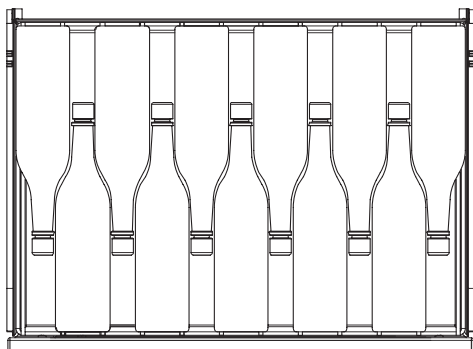

figure 4

Single Bottle Racks

Because bottles are not stacked on top of each other, you can easily view and access your inventory without disturbing other bottles.

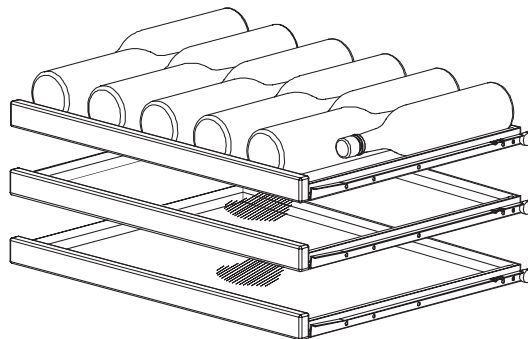

figure 5

THINGS TO REMEMBER

Loading Tips and Suggestions for Wine Rack

The wooden, bottom bottle cradle may be removed for storing "jug" wines. Just remove the two screws that secure the cradle to the cabinet floor.

You can store magnum bottles and other large bottles on any of the shelves (except for the top shelf) by removing the shelf directly above them or placing the shelf at a position allowing for proper clearance.

Commodities on the top rack directly under the light will be exposed to a slightly higher temperature when the light is on. REMEMBER TO TURN OFF THE LIGHT WHEN IT IS NO LONGER NEEDED.

Keep wines that you plan to use for everyday drinking and entertaining on the front half of the racks where labels are completely visible. Place wines for aging or longer term storing in rear.

What to do in the Event of a Power Failure

Most power failures are corrected within two hours and will not affect the unit's temperature providing you minimize the number of door openings while the power is off. A gradual rise in temperature should not have any adverse effect on your wine if power is out for a longer period. If it is extremely hot, you may want to move your wines to the coolest location you can find until power is restored.

Normal Responsibilities of the Owner Include

All freight charges.

Damage sustained in transit (see page 2)

Mileage charge(s) for service calls.

Proper installation.

Alterations to original equipment.

Removal or installation of additional equipment.

TROUBLESHOOTING

Before Calling for Service

Before calling for service, check the trouble shooting table on this page. This table lists possible problems that you can remedy without difficulty to avoid an unnecessary service call.

If you do need service, contact your dealer or the manufacturer. In any correspondence, refer to the model number and serial number of your unit which is located on the lower front cabinet flange. Retain you proof of purchase. You may want to record these numbers in the space provided on this page. Follow the procedure outlined on page 5.

Problem	Possible Causes/Solutions
Odor in cabinet	<ul style="list-style-type: none">• Interior needs cleaning
Noisy operation	<ul style="list-style-type: none">• Cabinet not level• Weak floor
Cabinet vibrates	<ul style="list-style-type: none">• Cabinet not level• Weak floor
Cabinet light not working	<ul style="list-style-type: none">• Tube burned out• No power at outlet
Appliance will not run	<ul style="list-style-type: none">• Temperature control turned to "OFF"• Line cord not plugged in• No power at electrical outlet• House fuse blown
Appliance runs too long	<ul style="list-style-type: none">• Prolonged door openings• Control set too cold• Condenser needs cleaning
Moisture collects inside	<ul style="list-style-type: none">• Too many door openings• Prolonged door openings• Hot, humid weather increases condensation
Moisture collects on outside surface	<ul style="list-style-type: none">• Hot, humid weather increases condensation. As humidity decreases, moisture will disappear.• Control improperly set.
Interior too hot/too cold	<ul style="list-style-type: none">• Control improperly set• Faulty thermometer• Relocate thermometer to center of cabinet and recheck

All specifications and product design subject to change without notice.
Such revisions do not entitle the buyer to corresponding changes, improvements, additions, replacements or compensation for previously purchased products.

SERVICE

How to Obtain Service

Your refrigerated beverage center requires little service because the best and most up to date materials, equipment and quality methods are employed throughout the manufacturing process.

If trouble occurs during normal operation, first check the troubleshooting chart on page 4 to see if any of these simple steps may correct the problem. If service becomes necessary:

Contact the dealer where your appliance was purchased or the manufacturer for the name of your nearest authorized service representative. The service representatives will have full authority to make any repair deemed necessary.

If you are in an area where there is no service representative, write or call the manufacturer directly. We will make recommendations as to the proper procedure for correction. Service work and replacement parts, if required, will be provided as covered by your limited warranty.

IT IS IMPORTANT THAT YOU SEND IN YOUR WARRANTY RECORD CARD IMMEDIATELY AFTER TAKING DELIVERY OF YOUR REFRIGERATION APPLIANCE.

Every new refrigeration appliance that leaves the factory contains this Owner's Guide in a safe place for convenient reference.

If You Do Need Service

In the event that you do need service, be sure to report the model number, serial number and proof of purchase to your service representative. Model number and serial number are found on the serial plate which is located on the lower front cabinet flange. For your convenience you may want to record the following information for your records.

<hr/>		
<i>Date of Purchase</i>		
<hr/>		
<i>Dealer's Name</i>		
<hr/>		
<i>Dealer's Address</i>		
<hr/>		
<i>Dealer's city</i>	<i>Dealer's State</i>	<i>Zip</i>
<hr/>		
<i>Appliance Serial Number</i>		
<hr/>		
<i>Model Number</i>		
<hr/>		
<i>Date Warranty Card Mailed (within 10 days of purchase)</i>		
<hr/>		

All specifications and product design subject to change without notice.
Such revisions do not entitle the buyer to corresponding changes, improvements,
additions, replacements or compensation for previously purchased products.

MARVEL HOUSEHOLD REFRIGERATION PRODUCTS LIMITED WARRANTY

Entire Product - Limited One Year Parts and Labor Warranty. MARVEL warrants that it will supply all necessary parts and labor to repair or replace in the end user's home or office, any component which proves to be defective in materials or workmanship, subject to the condition and exclusions stated below, for period of one year from date of purchase by the end user.

Additional Second Through Fifth Year Limited Parts Only Warranty. During the four years following expiration of the One Year Limited Warranty, MARVEL will supply replacement parts for the hermetically sealed refrigeration system which consists of the compressor, condenser, drier, connecting tubing and the evaporator that are proven to be defective due to workmanship or materials subject to the conditions and exclusions below.

The above warranties do not cover:

- Shipping costs of replacement parts or returned defective parts.
- Customer education or instructions on how to use the refrigerator/freezer.
- Any content loss due to product failure. - Removal or installation.

Nor do the above warranties cover failure of this product or its components due to:

- Transportation or subsequent damages.
- Use commercially or use other than normal household or office.
- Improper installation, misuse, abuse, accident or alteration, use on wiring not confirming to electrical codes, low voltage, failure to provide necessary maintenance, or other unreasonable use.
- Parts or service not supplied or designated by MARVEL.

The above warranties also do not apply if:

- The original Bill of Sale, deliver date or serial number cannot be verified.
- Defective parts are not returned for inspection if so requested by MARVEL.
- The refrigeration equipment is not in the possession of the original end use purchaser.

THE WARRANTIES SET FORTH HEREIN ARE THE ONLY WARRANTIES EXTENDED BY MARVEL INDUSTRIES. ANY IMPLIED WARRANTIES, INCLUDING THE IMPLIED WARRANTY OF MERCHANTABILITY, ARE LIMITED TO THE DURATION OF THESE EXPRESS WARRANTIES. IN NO EVENT SHALL MARVEL INDUSTRIES BE LIABLE FOR ANY CONSEQUENTIAL OR INCIDENTAL DAMAGES OR EXPENSES RESULTING FROM BREACH OF THESE OR ANY OTHER WARRANTIES, WHETHER EXPRESSED OR IMPLIED. Some states do not allow the exclusion or limitation of consequential damages or limitations on how long an implied warranty lasts, so the above exclusion or limitation may not apply to you. This warranty gives you specific legal rights, and you may also have other rights which may vary from state to state.

No person, firm or corporation is authorized to make any other warranty or assume any other obligation for MARVEL INDUSTRIES. These warranties apply only to products used in any of the fifty states of the United States and the District of Columbia.

To obtain performance of this warranty, report any defects to:

MARVEL INDUSTRIES
P.O. Box 997
Richmond, Indiana 47375-0997
Phone: 765-962-2521

IN NO EVENT SHALL THE COMPANY BE LIABLE FOR INCIDENTAL OR CONSEQUENTIAL DAMAGES INCLUDING, BUT NOT LIMITED TO, CONTENT LOSS.

Some states do not allow limitations on length of time implied warranty may last, so the above limitations may not apply to you.

This warranty gives you specific legal rights. You may also have other rights which vary from state to state.

MARVEL



WWW.MARVELINDUSTRIES.COM

Phone: (765) 962-2521 Fax: (765) 962-2493

An AGA Company
233 Industrial Parkway
P.O. Box 997
Richmond, IN 47375-0997

Free Manuals Download Website

<http://myh66.com>

<http://usermanuals.us>

<http://www.somanuals.com>

<http://www.4manuals.cc>

<http://www.manual-lib.com>

<http://www.404manual.com>

<http://www.luxmanual.com>

<http://aubethermostatmanual.com>

Golf course search by state

<http://golfingnear.com>

Email search by domain

<http://emailbydomain.com>

Auto manuals search

<http://auto.somanuals.com>

TV manuals search

<http://tv.somanuals.com>