BSD SERIES REFRIGERATORS AND FREEZERS

Installation, Operation and Maintenance Instructions

INSPECTION

When the equipment is received, all items should be carefully checked against the bill of lading to insure all crates and cartons have been received. All units should be inspected for concealed damage by uncrating the units immediately. If any damage is found, it should be reported to the carrier at once, and a claim should be filed with the carrier. This equipment has been inspected and tested at the manufacturing facility and has been crated in accordance with transportation rules and guidelines. Manufacturer is not responsible for freight loss or damage.

INSTALLATION

GENERAL

If casters are installed, care should be taken when removing the unit from the crate base. The unit is heavy and can present a hazard if not handled with care. Remove the unit crate and crate base. Discard hardware used to secure the cabinet to the crate base. Ensure that at least two persons are available to install the casters. Lay the cabinet on its back to create access to the cabinet bottom. Attach the casters to the cabinet base using the factory installed screws as shown below. Remove the $\frac{1}{4}$ x 20 x $\frac{3}{4}$ screws (4 per caster) that are factory installed. Position the caster and reinstall. Ensure that the locking casters are installed on the front of the cabinet. After installation is complete, return the cabinet to its upright position. The cabinet should set in the upright position for at least one hour prior to energizing. This is required to allow the refrigeration to settle to its normal state. The cabinet should also be levelled when it is placed in its permanent location.

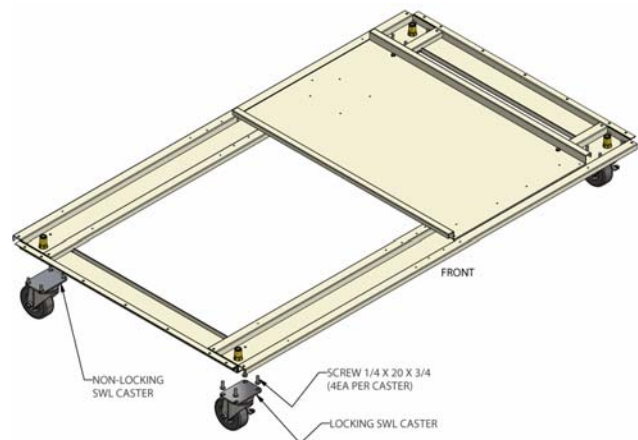

If the doors are out of alignment on the cabinet, the doors can be adjusted. This can be accomplished by opening the door(s) and loosening the screws that hold both the top and bottom hinges to the cabinet. After adjusting the door so that it is aligned correctly, tighten the screws to securely hold the hinges in place.

ELECTRICAL

Check the proposed outlet to be used to insure that the voltage, phase and current carrying capacity of the circuit from the electrical panel correspond to the requirements of the cabinet. NEVER use an extension cord to wire any unit. On permanently connected units, those not furnished with a plug-in service cord, all inter-wiring between the electrical panel and the unit must be done in accordance with the National Electric Code and all state and local codes. Refer to the serial tag for all pertinent electrical information.

Observe all Warning Labels. Disconnect power supply to eliminate injury from electrical shock or moving parts when servicing equipment.

GENERAL OPERATION

The refrigerators and freezers employ a unit cooler evaporator located outside the cabinet as the heat removing source. Through the refrigeration process, heat is captured in the evaporator, transferred to the condensing unit on top of the cabinet, and expelled to the surrounding outside air. It is extremely important to allow a four (4) inch clearance on the top, rear, and sides of the unit for the refrigeration process to function properly.

These refrigerators and freezers utilize a programmable controller to control the temperature and defrost settings. The controller, which is located on the facade of the unit, is factory set. Please see the default settings sheet and separate instructions that are included on the operation of this controller.

REFRIGERATORS

During the operation of a refrigerator unit, frost will periodically form on the coil surface. Each time the compressor cycles "off", the evaporator fans will continue to run, which will keep the internal temperature uniform and at the same time remove any frost build up on the coil. The water produced will collect in the unit cooler drain pan and travel down the drain tube to the condensate vaporizer.

FREEZERS

After shutting the door on freezer models, a short amount of time must be allowed before the door can be reopened. This is due to the tight seal maintained between the door and the cabinet. Waiting a few moments for the pressure to equalize permits the door to be opened easily.

A positive defrost is required to remove frost from the coil in freezer models. This is accomplished by energizing heaters during the defrost cycle that are positioned on the coil surface. The programmable controller is factory set to allow four defrosts per day.

As the preset defrost time is reached, the controller automatically terminates the refrigeration process by turning off the condensing unit and unit cooler fan motors, and energizes the defrost heaters. As the coil temperature increases, the frost begins to melt producing water which runs down the coil to the unit cooler drain pan and exits through the drain tube to the vaporizer. After all the frost has been removed and the coil temperature reaches approximately 50°F [10°C], the defrost is terminated through the action of the defrost termination control located on the unit cooler, and the refrigeration process resumes. In order to insure that any excess water remaining on the coil is not sprayed into the cabinet interior, and all heat generated by the defrost is removed, **the unit cooler fans will not operate until the coil temperature reaches approximately 25°F [-4°C].**

GENERAL MAINTENANCE

PERIODIC CLEANING

Beginning with the initial installation, the interior surfaces of the cabinet should be periodically wiped down with a solution of warm water and baking soda. This solution will remove any odors from spillage that has occurred. The exterior of the cabinet should also be cleaned frequently with a commercial grade of glass cleaner.

Monthly cleaning of the condenser will aid the heat transfer characteristics of the refrigeration system and increase its efficiency. To accomplish this, remove the cover panel from the cabinet and use a wire brush to loosen any dirt particles that are attached to the fins. Use a vacuum cleaner to remove the loosened particles. **Failure to keep the condenser coil clean and clear of obstructions could result in temperature loss and damage to the compressor.**

All moving parts have been permanently lubricated and will generally require no maintenance.

MAINTENANCE SERVICE AND ANALYSIS GUIDE
REFRIGERATION SYSTEMS - ALL MODELS

<u>MALFUNCTION</u>	<u>POSSIBLE CAUSE</u>	<u>SOLUTION</u>
Compressor will not start - no hum	<ol style="list-style-type: none"> 1. Service cord unplugged 2. Fuse blown or removed 3. Overload tripped 4. Control stuck open 5. Wiring incorrect 	<ol style="list-style-type: none"> 1. Plug in service cord 2. Replace fuse 3. Determine reasons and correct 4. Repair or replace 5. Check wiring against the diagram
Compressor will not start - hums but trips on overload protector	<ol style="list-style-type: none"> 1. Improperly wired 2. Low voltage to unit 3. Starting capacitor defective 4. Relay failing to close 	<ol style="list-style-type: none"> 1. Check wiring against the diagram 2. Determine reason and correct 3. Determine reason and replace 4. Determine reason, correct or replace
Compressor starts and runs, but short cycles on overload protector	<ol style="list-style-type: none"> 1. Low voltage to unit 2. Overload defective 3. Excessive head pressure 4. Compressor hot-return gas hot 	<ol style="list-style-type: none"> 1. Determine reason and correct 2. Check current, replace overload protector 3. Check ventilation or restriction in refrigeration system 4. Check refrigerant charge, fix leak if necessary
Compressor operates long or continuously	<ol style="list-style-type: none"> 1. Short of refrigerant 2. Control contact stuck 3. Evaporator coil iced 4. Restriction in refrigeration system 5. Dirty condenser 	<ol style="list-style-type: none"> 1. Fix leak, add charge 2. Repair or replace 3. Determine cause, defrost manually 4. Determine location and remove restriction 5. Clean condenser
Compressor runs fine, but short cycles	<ol style="list-style-type: none"> 1. Overload protector 2. Cold control 3. Overcharge 4. Air in system 5. Undercharge 	<ol style="list-style-type: none"> 1. Check wiring diagram 2. Differential too close - widen 3. Reduce charge 4. Purge and recharge 5. Fix leak, add refrigerant
Starting capacitor open, shorted or blown	<ol style="list-style-type: none"> 1. Relay contacts stuck 2. Low voltage to unit 3. Improper relay 	<ol style="list-style-type: none"> 1. Clean contacts or replace relay 2. Determine reason and correct 3. Replace
Relay defective or burned out	<ol style="list-style-type: none"> 1. Incorrect relay 2. Voltage too high or too low 	<ol style="list-style-type: none"> 1. Check and replace 2. Determine reason and correct
Refrigerated space too warm	<ol style="list-style-type: none"> 1. Control setting too high 2. Refrigerant overcharge 3. Dirty condenser 4. Evaporator coil iced 5. Not operating 	<ol style="list-style-type: none"> 1. Reset control 2. Purge refrigerant 3. Clean condenser 4. Determine reason and defrost 5. Determine reason, replace if necessary
Standard temperature system freezes the product	<ol style="list-style-type: none"> 1. Control setting is too low 2. Control points stuck 	<ol style="list-style-type: none"> 1. Reset the control 2. Replace the control
Objectionable noise	<ol style="list-style-type: none"> 1. Fan blade hitting fan shroud 2. Tubing rattle 3. Vibrating fan blade 4. Condenser fan motor rattles 5. General vibration 6. Worn fan motor bearings 	<ol style="list-style-type: none"> 1. Reform or cut away small section of shroud 2. Locate and reform 3. Replace fan blade 4. Check motor bracket mounting, tighten 5. Compressor suspension bolts not loosened on applicable models - loosen them 6. Replace fan motor
Pan Area	<ol style="list-style-type: none"> 1. No cooling 2. Too cold 3. Too warm 	<ol style="list-style-type: none"> 1. Make sure switch is in the "on" position 2. Adjust temperature control - see instructions under pan area 3. Adjust temperature control - see instructions under pan area

INSTRUCTIONS FOR REVERSING THE SWING OF SOLID DOORS

Complete the following steps if reversing the swing of the **solid door(s)** is desired. These steps apply to both refrigerators and freezers.

1. With a one, two, or three door model, first open the door and locate the screws holding the hinges and door in position.
2. Two people are recommended to make this change. One person should hold the door at a 90° angle to the cabinet while the other person removes the screws holding the door to the cabinet. The normal installation at the factory is to have the spring loaded door-closing mechanism located at the bottom of the cabinet. **When removing the spring tension bracket from the cabinet bottom, be careful that it does not snap back. This may result in pinched fingers.**
3. After the door(s) are removed, remove the door lock strike(s) from the cabinet by removing the two mounting screws.
4. Find the holes, drilled through the outer skin only, located on the opposite side of the door opening from where the hinges were previously located. Drill through the tapping plate found behind these holes using a 7/32" drill bit.
5. Turn the door over and align it to the cabinet so it will swing in the desired direction. The spring loaded door-closing hinge will now be located at the top of the reversed door. Mount the hinges to the cabinet using the holes that were drilled out in step 4, along with the previously removed screws. Check the door(s) to be certain that it is mounted squarely and that the gaskets seal properly around the door opening. The door can be adjusted by moving the top or bottom hinge slightly.
6. The original hinge holes can be filled with silicone, or with 1/4-20x3/4 pan head stainless steel screws if desired.
7. Locate the door lock strike by visually aligning it to the dead bolt lock in the door while the door is in the closed position. While holding the strike in position, mark the top, bottom, and edge of the strike on the cabinet wall or mullion with a pencil or fine point marker that will remain legible until completion of the task. Verify that the strike is positioned properly by assuring that it is aligned to the marks and hold it securely; open and close the door and extend and retract the dead bolt to make certain they clear without touching. **The strike cannot be adjusted after it is mounted.**
8. Align the strike to the marks, which were made in step 7 and mark the centers of the holes for the mounting screws. Using a #20 drill bit, drill the holes you just marked approximately one-half inch deep. **Take care not to puncture the interior side of the cabinet.** Note: If a #20 bit is not available, use a 5/32" drill bit.
9. Mount the door lock strike using the screws that were removed from the original position. The screws may have to be forced until the thread cutting tip has passed through the entire metal thickness. The original door strike holes can be filled with silicone, or with two 10-24x1/2 stainless steel pan head screws if desired.

Electronic Refrigeration Control Parameters

Technologic TLZ 20 Controller

Label	Parameter	Minimum to Maximum Ranges	Set Points
SPLL	MinimumSet Point	-58°F to SPHL	-50°F
SPHL	Differential	SPLL to 302°F	100°F
SEnS	Probe Type	PTC - NTC	NTC
OFS	Probe Calibration	-30°F to 30°F	0
Unit	Unit of Measurement	°C - °F	°F
dP	Decimal point	On - OFF	ON
FIL	Measurement Filter	OFF to 20 Sec.	0
HSET	Differential	0 to 30°F	4°F
tonE	Activation time output OUT for probe broken	OFF to 99.59 min.sec.	15 min.
toFE	Deactivation time output OUT for probe broken	0 to 50 minutes	30 min
Func	Function mode output OUT	HEAt to Cool	Cool
dint	Defrosting interval	OFF to 24 hrs.	12 hrs.
dEFE	Length of defrost cycle	0.01 to 99.59 min.sec.	15 min.
dCT	Defrosting intervals Counting mode: rt = reat time ct = on OUT time	rt or ct	rt
dLo	Defrost display lock OFF = display free On = Lock on temperature before defrost Lb = Lock on label "deF" (during defrost) and PdEF (during post defrosting)	ON - OFF - Lb	Lb
Etdu	Differential display unlock after defrost	0.0 to 30°F	0
PSC	Type of compressor protection 1 = delay at switch on 2 = delay at switch off 3 = delay between starts	1, 2, 3	1
PtC	Compressor protection time	OFF to 99.59 min.sec.	OFF
od	Delay at power on	OFF to 99.59 min.sec.	OFF
dALd	Unlock display delay after defrost	OFF to 24 hrs.min.	OFF
USrb	Function mode key U: OFF = No function, 1 = ON/STANDBY	OFF / 1	OFF
PASS	Access Password to parameter functions	OFF to 9999	OFF
SP	Set Point	SPLL to SPHL	35

ERROR SIGNALS

E1	Probe Interruption
EEPr	Internal Memory Error
od	Delay in switching on in progress
dEF	Defrosting in progress with "dLo" = Lb
PdEF	Post defrosting in progress with "dLo" = Lb

4/13/07 138662

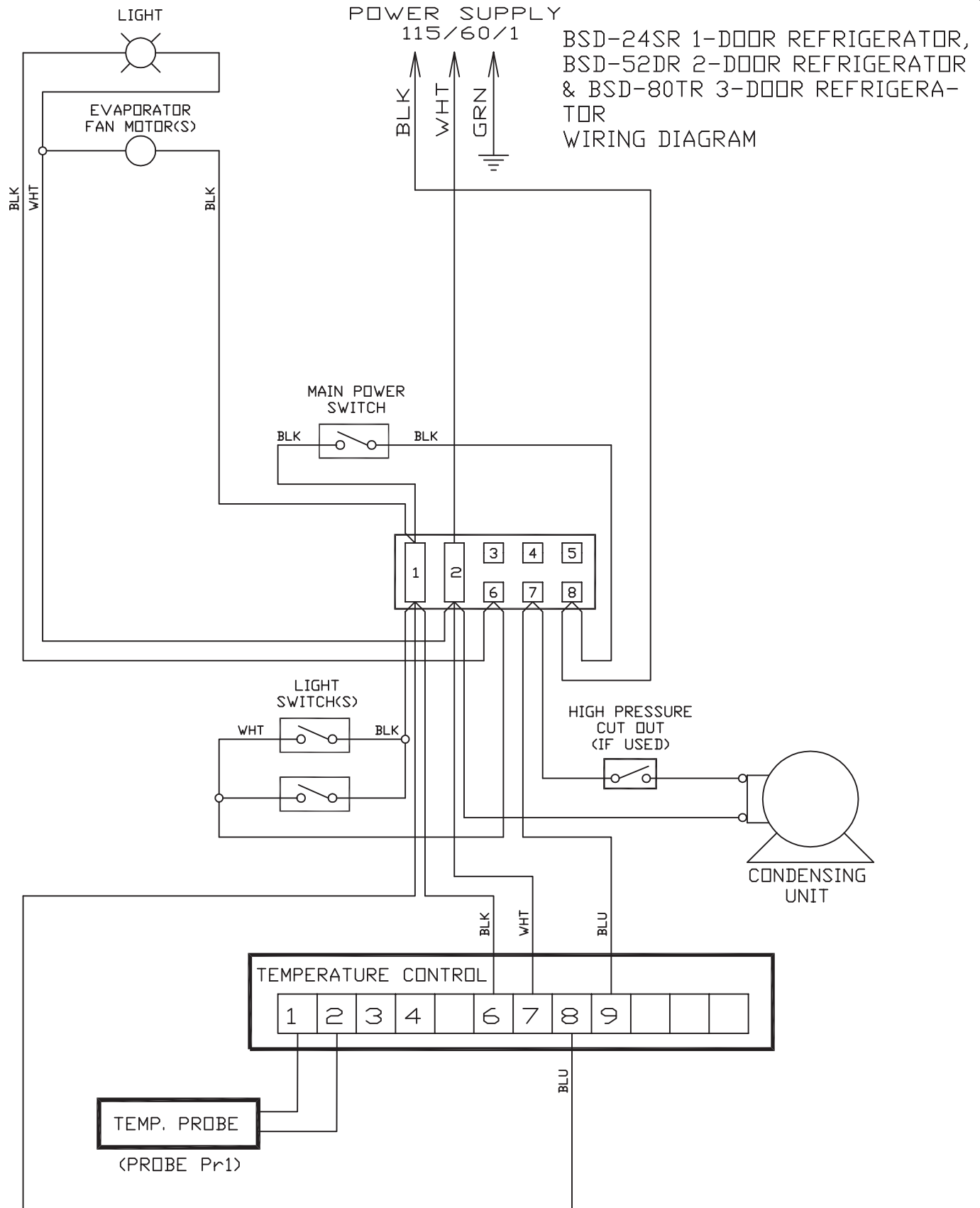

PROPERTY OF	
TITLE	WIRE DIAGRAM
MAT'L	BSD-24SR, BSD-52DR, BSD-80TR 115/60/1 VAC
DRAWN	JMS DATE 01/18/07
CHECKED	DATE SHEET NO. 1 of 1
PART NO.	DWG NO. A30658
	REV. NO. B

REV.	DESCRIPTION	ECN NO.	DRW/ENG	DATE
B	ADDED WIRE COLORS		JMS RM	05/06/07
A	ORIGINAL ISSUE		JMS FJM	01/18/06

PART NO.	130965
DRWG NO.	A30658
BOLD LINES INDICATE FIELD WIRING BY OTHERS	
TORQUES:	
MAIN LUGS:	
#14 TO #10	32 INLBS
#8 TO #6	35 INLBS
#6 TO #4	41 INLBS
#3 TO #2	45 INLBS
CONTACTORS AND RELAYS	
#14 TO #10	35 INLBS

BSD-24SF
 1-DOOR FREEZER
 & BSD-52DF
 2-DOOR FREEZER
 WIRING DIAGRAM

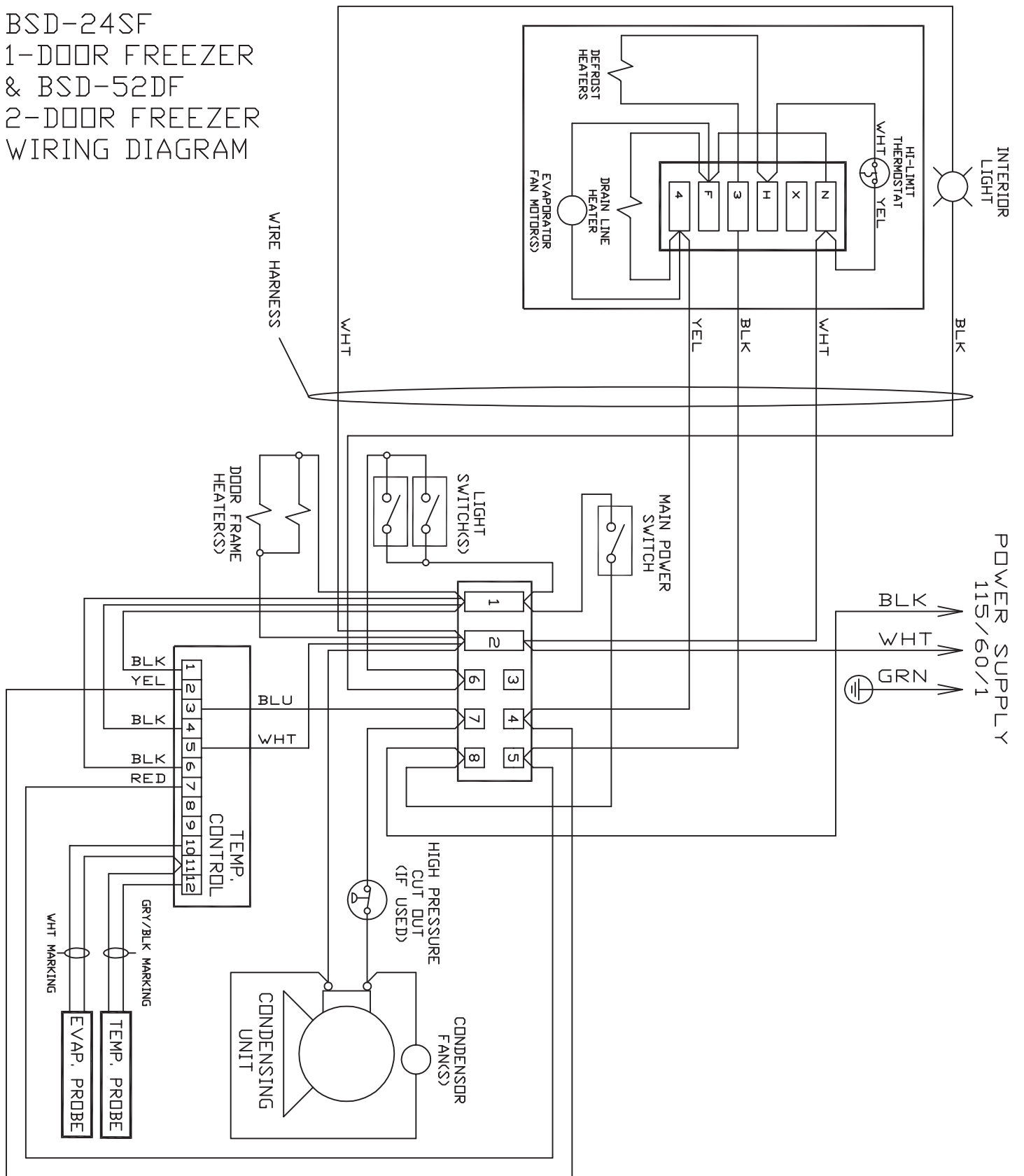

PROPERTY OF		PART NO. 130961		DRAWG NO. A30655	
TITLE WIRE DIAGRAM		BOLD LINES INDICATE FIELD WIRING BY OTHERS		TORQUES: #14 TO #10 32 INLBS #8 TO #4 35 INLBS #6 TO #4 41 INLBS #3 TO 2/0 45 INLBS CONTACTORS AND RELAYS #14 TO #10 35 INLBS	
MATERIAL BSD-24SF, BSD-52DF 115/60/1 VAC		DATE 01/09/07		DATE 05/25/07	
DRAWN JMS		APPROVED		DATE 01/09/07	
CHECKED		SHEET NO. 1 of 1		DATE	
PART NO. 130961		DWG NO. A30655		REV. NO. C	
REVISIONS		DESCRIPTION		DATE	
A		ORIGINAL ISSUE		JMS RM 05/25/07	
B		CHG TO XRD6C CTL.		JMS RM 05/25/07	
C		ADDED COLOR MKGS TO PROBES		JMS RM 05/07/07	

BSD-80TF 3-DOOR FREEZER WIRING DIAGRAM

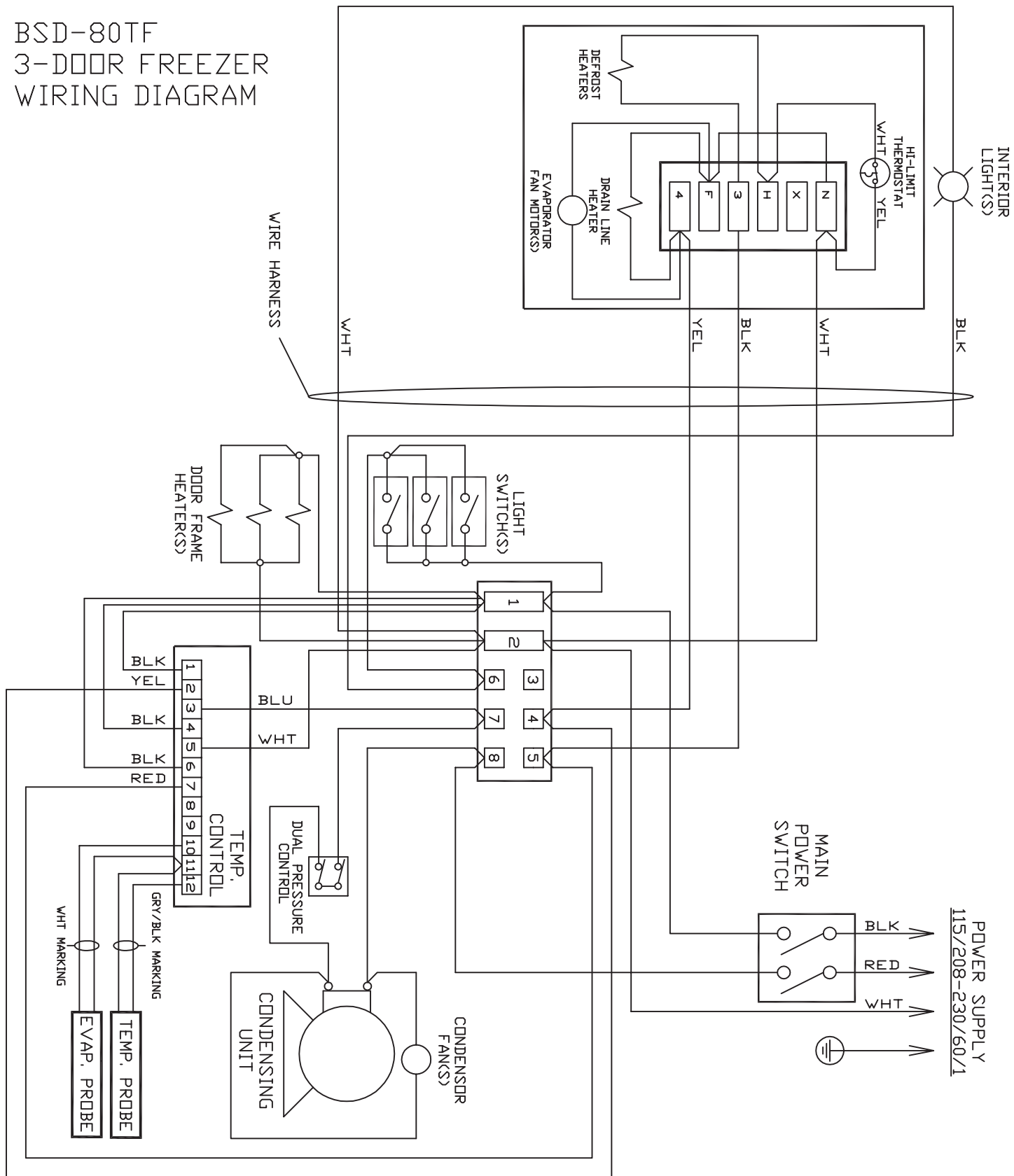

PROPERTY OF		PART NO. 130962		DRAWG NO. A30656	
TITLE WIRE DIAGRAM		BOLD LINES INDICATE FIELD WIRING BY OTHERS		TORQUES:	
MAT'L BSD-80TF 115/208-230/60/1 VAC		MAIN LUGS:		#14 TO #10 32 INLBS	
DRAWN JMS DATE 02/12/07		APPROVED		#8 TO #4 41 INLBS	
CHECKED DATE		SHEET NO. 1 of 1		#3 TO 2/0 45 INLBS	
PART NO. 130962		DWG NO. A30656		CONTACTORS AND RELAYS #14 TO #10 35 INLBS	
REV. NO. C		REVISIONS		REV. DESCRIPTION ECN NO. DRW/ENG DATE	
A		ORIGINAL ISSUE		JMS RM 05/07/07	
B		CHG TO XR06C CTL.		JMS RM 05/29/07	
C		ADDED COLOR MKGS TO PROBES		JMS RM 02/12/07	

Free Manuals Download Website

<http://myh66.com>

<http://usermanuals.us>

<http://www.somanuals.com>

<http://www.4manuals.cc>

<http://www.manual-lib.com>

<http://www.404manual.com>

<http://www.luxmanual.com>

<http://aubethermostatmanual.com>

Golf course search by state

<http://golfingnear.com>

Email search by domain

<http://emailbydomain.com>

Auto manuals search

<http://auto.somanuals.com>

TV manuals search

<http://tv.somanuals.com>