

# **MB MASTER-BILT**<sup>®</sup>

**™** *Refrigeration Solutions*

MPMIQMPM-36

MPMIQMPM-48

MPMIQMPM-72

## **Installation & Operations Manual**

**Master-Bilt Products**  
908 Highway 15 North  
New Albany, MS 38652  
Phone: (800) 684-8988

PN 071-90000  
Rev 03/06/08



## TABLE OF CONTENTS

<b>INTRODUCTION</b> .....	<b>4</b>
<b>STORE CONDITIONS / LOCATION</b> .....	<b>4</b>
<b>WARNING LABELS AND SAFETY INSTRUCTIONS</b> .....	<b>5</b>
<b>PRE-INSTALLATION INSTRUCTIONS</b> .....	<b>6</b>
Inspection for Shipping Damage.....	6
<b>INSTALLATION INSTRUCTIONS</b> .....	<b>6</b>
General Instructions.....	6
Thermometer Installation.....	6
Condensate Evaporator.....	8
Power Toggle Switch.....	8
Electrical.....	8
<b>STARTING PROCEDURE</b> .....	<b>8</b>
<b>FINAL CHECK LIST</b> .....	<b>8</b>
<b>LOADING</b> .....	<b>9</b>
<b>CLEANING</b> .....	<b>9</b>
<b>SERVICE INSTRUCTIONS (Trouble Shooting Guide)</b> .....	<b>9</b>
<b>MASTER-BILT PART NUMBERS</b> .....	<b>9</b>
<b>ACCESSORIES LIST</b> .....	<b>10</b>
<b>SALE AND DISPOSAL</b> .....	<b>11</b>
<b>WIRING DIAGRAMS</b> .....	<b>12</b>

## INTRODUCTION

Thank you for purchasing a Master-Bilt cabinet. This manual contains important instructions for installing, using and servicing a Master-Bilt **MPM/QMPM** series open air case. Read all these documents carefully before installing or servicing your equipment. This manual should be left in the care of the store owner or manager.

## STORE CONDITIONS / LOCATION

The Master-Bilt **MPM/QMPM** cases are designed to operate in the controlled environment of an air conditioned store. The store temperature should be at or below 75°F and a relative humidity of 55% or less. At higher temperature or humidity conditions, the performance of these cases may be affected and the capacity diminished. It is not uncommon in a newly constructed store for the temperature and humidity to be above design conditions. These excessive conditions may produce sweating in the case until the store is operational and the ambient environment is more desirable.

The Master-Bilt **MPM/QMPM** should not be positioned where it is directly exposed to rays of the sun or near a direct source of radiant heat or air flow. No HVAC return or supply air ducts may be located near case openings. This will adversely affect the case air flow and will result in poor performance. Do not open windows or doors that will affect the case air flow. The maximum air velocity near the case air return is 50 FPM. If this case is to be located against a wall there should be at least a 6" space between the wall and the back of the case. The cabinet also requires a clearance of 10" at the top. This space will allow for the circulation of air behind the case.

These cases should always be loaded properly. This unit will operate differently when loaded or unloaded. Consult the section of this manual that specifies loading procedures on page 6.

A P-trap is included with each case. It is important that each case has a P-trap installed. Check drain tubing to insure that it is trapped and routed into the condensate pan.



### NOTICE

**Read this manual before installing your cabinet. Keep the manual and refer to it before doing any service on the equipment. Failure to do so could result in personal injury or damage to the cabinet.**



### DANGER

**Improper or faulty hook-up of electrical components of the refrigeration units can result in severe injury or death.**

**All electrical wiring hook-ups must be done in accordance with all applicable local, regional or national standards.**



### NOTICE

**Installation and service of the refrigeration and electrical components of the cabinet must be performed by a refrigeration mechanic and/or a licensed electrician.**

The portion of this manual covering refrigeration and electrical components contains technical instructions intended only for persons qualified to perform refrigeration and electrical work. This manual cannot cover every installation, use or service situation. If you need additional information, call or write us:

Customer Service Department  
Master-Bilt Products  
908 Highway 15 North  
New Albany, MS 38652  
Phone: 800-684-8988  
Fax: 866-882-7629

## WARNING LABELS AND SAFETY INSTRUCTIONS



This symbol is the safety-alert symbol. When you see this symbol on your cabinet or in this manual, be alert to the potential for personal injury or damage to your equipment.

Be sure you understand all safety messages and always follow recommended precautions and safe operating practices.



### NOTICE TO EMPLOYERS

**You must make sure that everyone who installs, uses or services your cabinet is thoroughly familiar with all safety information and procedures.**

Important safety information is presented in this section and throughout this section and throughout the manual. The following signal words are used in the warnings and safety messages:

**DANGER:** Severe injury or death will occur if you ignore the message.

**WARNING:** Severe injury or death can occur if you ignore the message.

**CAUTION:** Minor injury or damage to your cabinet can occur if you ignore the message.

**NOTICE:** This is important installation, operation or service information. If you ignore the message, you may damage your cabinet.

**The warning and safety labels shown throughout this manual are placed on your Master-Bilt Products cabinet at the factory. Follow all warning label instructions. If any warning or safety labels become lost or damaged, call your customer service department at (662) 534-9061 for replacements.**

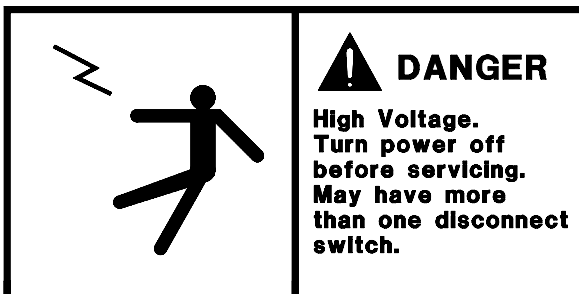

*This label is located on top of the electrical control label and on the wiring channel.*

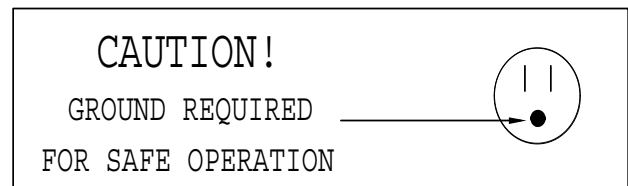

*This label is attached to the cabinet power cord on models with a power cord.*

## PRE-INSTALLATION INSTRUCTIONS

### INSPECTION FOR SHIPPING DAMAGE

You are responsible for filing all freight claims with the delivering truck line. Inspect all cartons and crates for damage as soon as they arrive. If damage is noted to shipping crates or cartons or if a shortage is found, note this on the bill of lading (all copies) prior to signing.

If damage is discovered when the cabinet is uncrated, immediately call the delivering truck line and follow up the call with a written report indicating concealed damage to your shipment. Ask for an immediate inspection of your concealed damage item. Crating material must be retained to show the inspector from the truck line.

# INSTALLATION INSTRUCTIONS

## GENERAL INSTRUCTIONS

1. Be sure the equipment is properly installed by competent service people.
2. Keep the equipment clean and sanitary so it will meet your local sanitation codes. Wipe up all spills, clean with water and a mild detergent, then rinse with clean water. A reservoir is provided to contain interior spills. Periodically inspect reservoir and clean as needed.
3. Rotate your stock so that older stock does not accumulate. A "First-In, First-Out" rotation practice will keep the products in good salable condition.
4. Product should not be put in the case for at least 6 hours after it is started.
5. Stock cases as quickly as possible, exposing only small quantities to store temperatures for short periods of time.
6. When replacing burned out fluorescent tubes, be sure that the electrical power to the lighting circuit is turned off.

## INSTALLATION INSTRUCTIONS

To comply with N.S.F. requirements, this cabinet must be mounted on casters or the base must be sealed to the floor with NSF listed silicone sealant. Optional casters screw into the holes from which the shipping bolts were removed. Minimum clearance as follows: 10" air space at top, 6" at the rear, and 0" air space at each side required for compliance. This space will allow for the circulation of air behind the case which will prevent condensation on the exterior surfaces.

Before moving cabinet into place, route cabinet plumbing with P-trap to store drain line or install optional condensate pan.

## THERMOMETER INSTALLATION

ANSI/NSF 7, requires that the provided thermometer be installed in the warmest part of the case. Testing has shown that the sides of the refrigerated space near the load line is the warmest, place see figure 1.1 below. Remove the tape backing and press the thermometer in place.

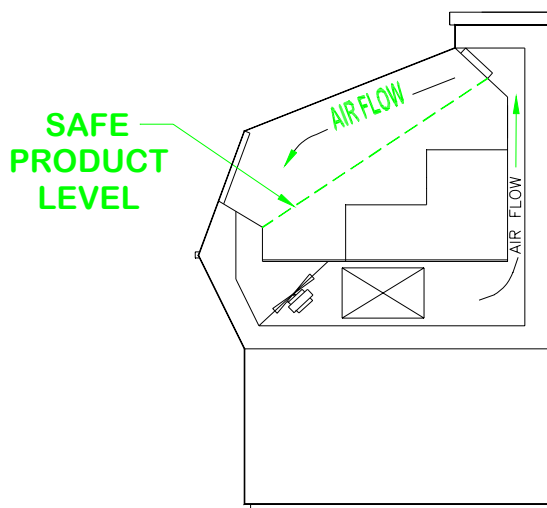

FIGURE 1.1  
(MPM SHOWN – Typical for QMPM)

## CONDENSATE EVAPORATOR

The **MPM/QMPM** is designed to operate in an environment of 75° ambient and 55% relative humidity. When the conditions are applicable for condensation such as high temperature and high humidity, a large capacity condensate evaporator has been installed in the **MPM/QMPM** to ensure proper evaporation.

## POWER TOGGLE SWITCH

The toggle switch turns the power ON or OFF and is accessible through a slot at the back of the **MPM/QMPM-36** and **MPM/QMPM-48** cabinet.



### NOTICE TO STORE OWNERS / MANAGERS

**Moisture or liquid around or under the cabinet is a potential slip/fall hazard for persons walking by or working in the general area of the cabinet. Any cabinet malfunction or housekeeping problem that creates a slip/fall hazard around or under the cabinet should be corrected immediately.**

If moisture or liquid is observed around or under a Master-Bilt cabinet, an immediate investigation should be made by qualified personnel to determine the source of the moisture or liquid. The investigation made should determine if the cabinet is malfunctioning or if there is a drain pipe leaking.

## ELECTRICAL



### WARNING

**Before servicing electrical components in the case make sure all power to case is off. Always use a qualified technician.**

## STARTING PROCEDURE

1. Start compressor and allow to run at least 6 hours before placing product into the **MPM/QMPM**.

DURING THIS TESTING PERIOD YOU SHOULD:

1. Check the temperature holding range against the the control setting.
2. Check the defrost control system to see that all ice is removed from the coil during each defrost cycle.
3. Check pressures.

## FINAL CHECK LIST

- |   |   |
|---|---|
| A. Check setting of defrost timer:<br>1. Verify setting of four <u>34</u> minutes defrost per 24 hours. | F. Check condensing unit for vibrating or rubbing tubing. Dampen and clamp as required. |
| B. Check operating pressures.   | G. All valves should be completeley open counter-clockwise.                             |
| C. Check electrical requirements of unit to supply voltage.   | H. Check packing nuts on all service valves.  |
| D. Set temperature control for desired temperature range.   | I. Replace all service valve caps and latch unit covers                                 |
| E. Check system for proper defrost operation.   |   |



## LOADING

Do not place product in the case until 6 hours after it is started. Stock cases as quickly as possible, exposing only small quantities to store temperatures for short periods of time. It is important to keep stock rotated properly so that older stock does not accumulate. A "First-In, First-Out" rotation practice will keep the products in good salable condition. Avoid loading the case so that product sticks out beyond the shelves or blocking the return air grille at the bottom of the case. This will interfere with the air flow of the case and will result in diminished performance.

## CLEANING



To avoid electrical shock, turn the power off before cleaning.

The QMVM series cabinets are designed so that spills will accumulate in a drain pan. The drain pan is located underneath the return air grill. Be sure to clean all areas with a mild detergent and water periodically.

## SERVICE INSTRUCTIONS (Trouble Shooting Guide)

1. High head pressure and high back pressure:
  - A. Condenser coil clogged or restricted.
  - B. Condenser fan motor defective.
2. Low back pressure and low head pressure:
  - A. Restriction in system.
  - B. Refrigerant undercharged.
  - C. Leak in system.
3. Pressures normal – cabinet warm:
  - A. Coil blocked with frost or ice (see #4).
  - B. Control set too warm.
  - C. Air screen disturbance.
4. Coil blocked with frost or ice:

<ol style="list-style-type: none"><li>A. Defective temperature control.</li><li>B. Time clock not operating properly.</li><li>C. Improper time clock setting.</li><li>D. Ambient conditions above 75 F/55</li></ol>	<ol style="list-style-type: none"><li>E. P-trap in drain not installed.</li><li>F. Evaporator fan motor defective.</li><li>G. Air screen disturbance.</li></ol>
---	---
5. Compressor starts and runs – but cycles on overload:
  - A. Low voltage.
  - B. Dropped phase (3 phase).
  - C. Overload protector defective.
  - D. High head pressure (see#1).
  - E. Relay or Capacitor defective.
6. Compressor will not start – hums, but cycles on overload:
  - A. Low voltage.
  - B. Relay defective.
  - C. Overload protector defective.
  - D. Start capacitor defective.
  - E. High head pressure (see #1)

## MASTER-BILT PART NUMBERS

The table below gives Master-Bilt part numbers. Use this chart when ordering replacement parts for your **MPM/QMPM** cases.

*All quantities are one each unless otherwise noted by parentheses.*

Description	MPM-36 QMPM-36	MPM-48 QMPM-48	MPM-72 QMPM-72
Anti-Sweat Heater-Side	17-09121	17-09122	17-09130
Anti-Sweat Heater-Front	17-09119	17-09120	17-09131
Condensate Pan Heater	17-09140	17-09140	17-09140
Condensing Unit	03-14234	01-01474	01-01477
Drier	09-09309	09-09307	09-09185
Evaporator Coil	07-13102	07-13103	07-13106
Evaporator Fan Blade	15-01184	15-01184	15-01184
Evaporator Fan Motor	13-00685	13-00685	13-00685
Expansion Valve			09-09548
Female Plug	21-00577	21-00577	21-00577
Power Cord	21-00312	21-01218	
Temperature Control	19-13092	19-13092	19-13092
Timer	19-00819	19-00819	19-00819
Toggle Switch	19-01090	19-01090	

## ACCESSORIES LIST

PART NO.	DESCRIPTION	SHIP WT. LB/KG
	<b>BUMPER KITS</b>	
A071-00100	White bumper for QMPM-36, QMVM-36 and QMVM-36L	5/2
A071-00200	Red bumper for QMPM-36, QMVM-36 and QMVM-36L	5/2
A071-00300	Green bumper for QMPM-36, QMVM-36 and QMVM-36L	5/2
A071-00400	Blue bumper for QMPM-36, QMVM-36 and QMVM-36L	5/2
A071-00500	Brown bumper for QMPM-36, QMVM-36 and QMVM-36L	5/2
A071-00600	Black bumper for QMPM-36, QMVM-36 and QMVM-36L	5/2
A072-00100	White bumper for QMPM-48, QMVM-48 and QMVM-48L	5/2
A072-00200	Red bumper for QMPM-48, QMVM-48 and QMVM-48L	5/2
A072-00300	Green bumper for QMPM-48, QMVM-48 and QMVM-48L	5/2
A072-00400	Blue bumper for QMPM-48, QMVM-48 and QMVM-48L	5/2
A072-00500	Brown bumper for QMPM-48, QMVM-48 and QMVM-48L	5/2
A072-00600	Black bumper for QMPM-48, QMVM-48 and QMVM-48L	5/2
A073-00100	White bumper for QMPM-72 and QMVM-72	5/2
A073-00200	Red bumper for QMPM-72 and QMVM-72	5/2
A073-00300	Green bumper for QMPM-72 and QMVM-72	5/2
A073-00400	Blue bumper for QMPM-72 and QMVM-72	5/2
A073-00500	Brown bumper for QMPM-72 and QMVM-72	5/2
A073-00600	Black bumper for QMPM-72 and QMVM-72	5/2

PART NO.	DESCRIPTION	SHIP WT. LB/KG
	<b>CASTERS</b>	
A075-11140	Set of 4, 3" dia. for QMPM/MPM-36 and QMPM/MPM-48	17/8
A076-11140	Set of 6, 3" dia. for QMPM/MPM-72	26/12
	<b>SANDWICH RACKS - WELDED WIRE, CHROME PLATED</b>	
33-01450	16" L for QMPM and MPM models (Max. number of racks per model: -36 size: 2, -48 size: 3, -72 size: 4)	8/4
	<b>DIVIDERS FOR SANDWICH RACKS</b>	
33-01452	All QMPM and MPM models	1/0.5
	<b>NIGHT CURTAIN KIT - WHITE (MUST BE FACTORY INSTALLED)</b>	
A071A11131	For QMPM/MPM-36	10/5
A072A11131	For QMPM/MPM-48	10/5
A073A11131	For QMPM/MPM-72	10/5
	<b>NIGHT CURTAIN KIT - BLACK (MUST BE FACTORY INSTALLED)</b>	
A071AB1131	For QMPM/MPM-36	10/5
A072AB1131	For QMPM/MPM-48	10/5
A073AB1131	For QMPM/MPM-72	10/5
	<b>LIGHT KIT - WHITE (MUST BE FACTORY INSTALLED)</b>	
A071A11151	For QMPM/MPM-36	15/7
A072A11151	For QMPM/MPM-48	15/7
A073A11151	For QMPM/MPM-72	15/7
	<b>LIGHT KIT - BLACK (MUST BE FACTORY INSTALLED)</b>	
A071AB1151	For QMPM/MPM-36	15/7
A072AB1151	For QMPM/MPM-48	15/7
A073AB1151	For QMPM/MPM-72	15/7
	<b>NIGHT CURTAIN &amp; LIGHT KIT - WHITE (MUST BE FACTORY INSTALLED)</b>	
A071A11141	For QMPM/MPM-36	15/7
A072A11141	For QMPM/MPM-48	15/7
A073A11141	For QMPM/MPM-72	15/7
	<b>NIGHT CURTAIN &amp; LIGHT KIT - BLACK (MUST BE FACTORY INSTALLED)</b>	
A071AB1141	For QMPM/MPM-36	15/7
A072AB1141	For QMPM/MPM-48	15/7
A073AB1141	For QMPM/MPM-72	15/7

## **SALE AND DISPOSAL**

### **OWNER RESPONSIBILITY**

If you sell or give away your Master-Bilt cabinet you must make sure that all safety labels and the Installation - Service Manual are included with it. If you need replacement labels or manuals, Master-Bilt will provide them free. Contact the customer service department at Master-Bilt at (800) 684-8988.

The customer service department at Master-Bilt should be contacted at the time of sale or disposal of your cabinet so records may be kept of its new location.

If you sell or give away your Master-Bilt cabinet and you evacuate the refrigerant charge before shipment, Master-Bilt recommends that the refrigerant charge be properly recovered in compliance with section 608 of the Clean Air Act effective November 1995 and in accordance with all applicable local, regional, or national standards.

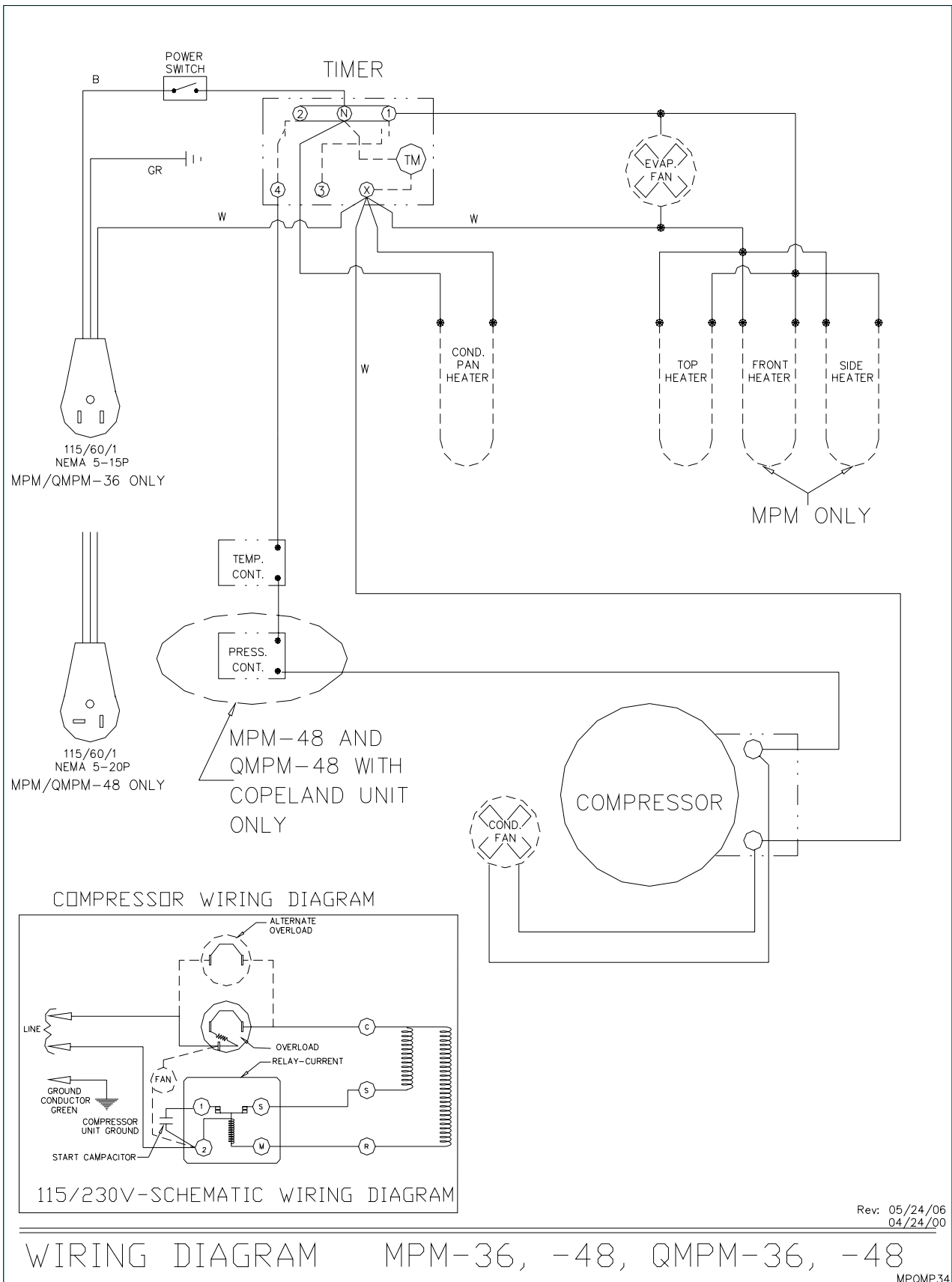

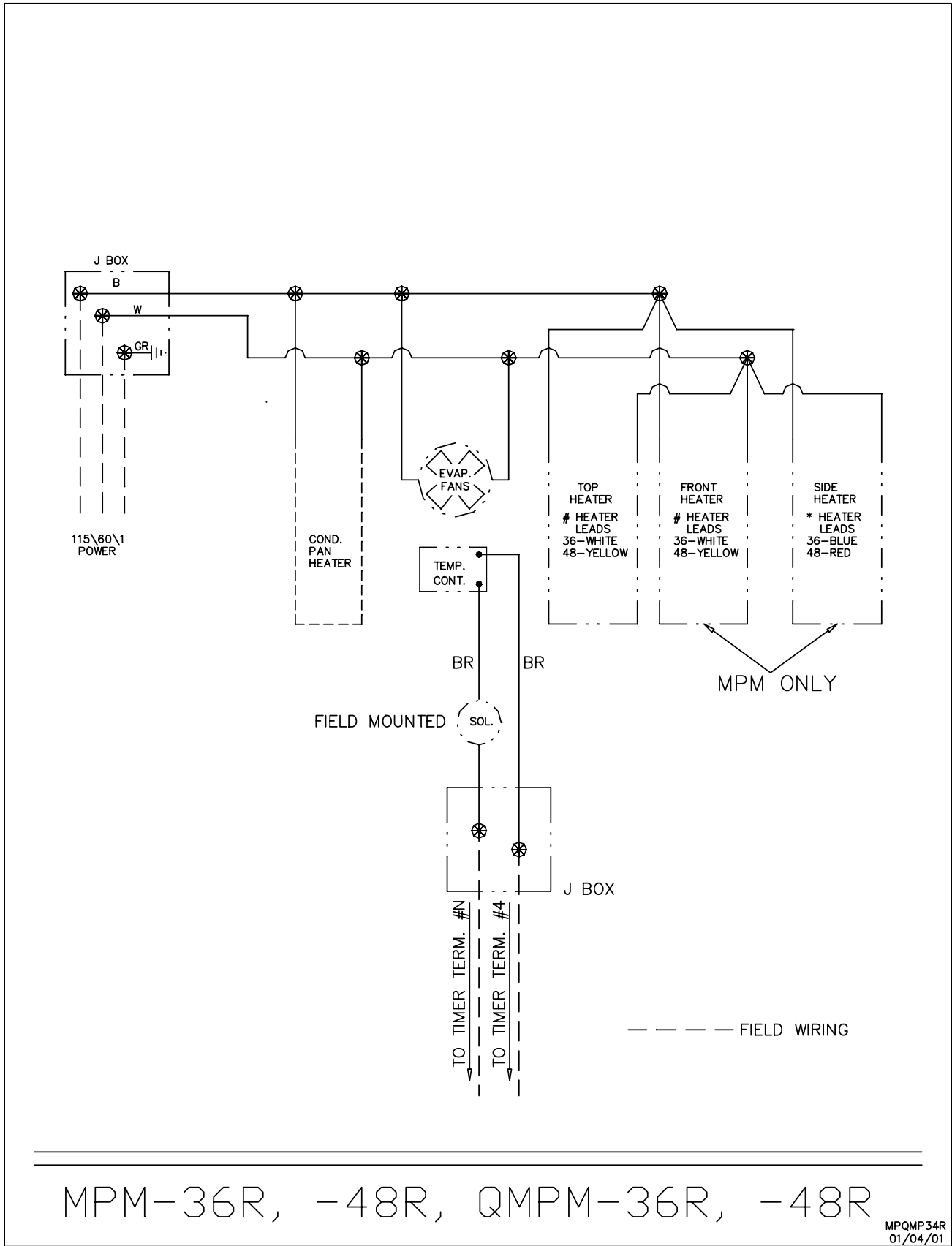

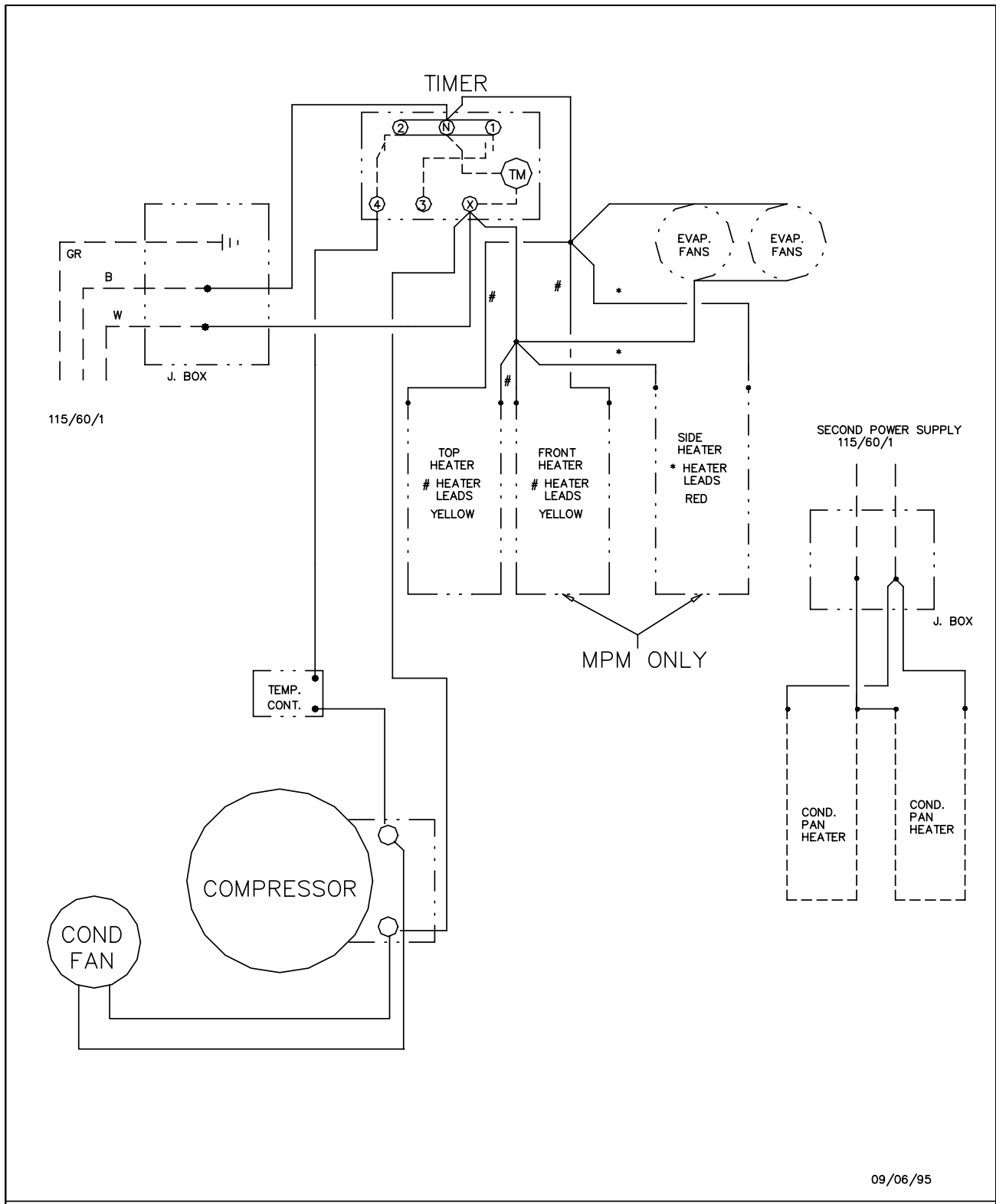

MPM-72, QMPM-72

MPM7

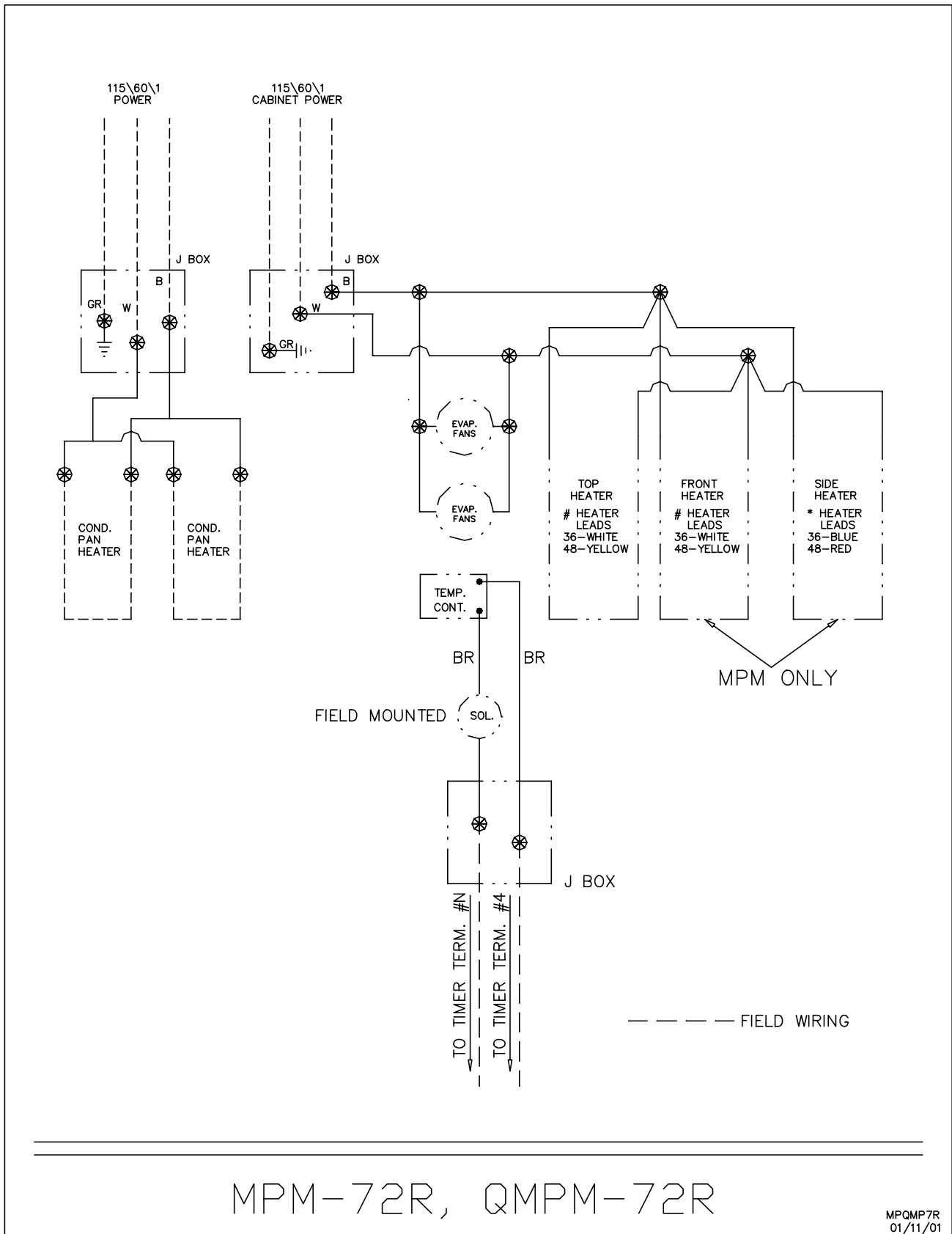



## Free Manuals Download Website

<http://myh66.com>

<http://usermanuals.us>

<http://www.somanuals.com>

<http://www.4manuals.cc>

<http://www.manual-lib.com>

<http://www.404manual.com>

<http://www.luxmanual.com>

<http://aubethermostatmanual.com>

Golf course search by state

<http://golfingnear.com>

Email search by domain

<http://emailbydomain.com>

Auto manuals search

<http://auto.somanuals.com>

TV manuals search

<http://tv.somanuals.com>