

# **MASTER<sup>®</sup>**

## **PORTABLE GASOLINE GENERATORS**

### **OWNER'S OPERATION AND INSTALLATION MANUAL**



**Generator Models: HWI3000, MGH3000, MGH3000PR, MGH4000C, MGH4000CI, MGH5000D, MGH5000DI, MGH5000DIE, MGH6000D, MGH6000DI, MGH7000D, MGH7000DI, and MGH10000A**

**IMPORTANT: Read and understand this manual before operating or servicing generator. Improper use of generator can cause serious injury. Keep this manual for future reference.**

# MASTER

## PORTABLE GASOLINE GENERATORS

### SAFETY INFORMATION

#### WARNINGS

**IMPORTANT:** Read this owner's manual and the engine owner's manual carefully. Become familiar with this generator before trying to operate or service it. Know its uses, limitations, and any hazards involved. Improper use of generator can cause severe injury or death from explosion, fire, burns, electrical shock, or carbon monoxide poisoning.

** DANGER:** Carbon monoxide poisoning may lead to death!

Engine exhaust contains poisonous carbon monoxide gas. Overexposure will cause loss of consciousness and will lead to death. Use only in well-vented areas. Make sure area has plenty of free-moving, fresh, outside air. Never run generator in an enclosed or confined area. Never run generator inside occupied building.

**Carbon Monoxide Poisoning:** Early signs of carbon monoxide poisoning resemble the flu, with headaches, dizziness, and nausea. **If you have these signs, get fresh air at once!** Some people are more affected by carbon monoxide than others. These include pregnant women, persons with heart or lung disease or anemia, those under the influence of alcohol, and those at high altitudes. Make certain you read and understand all warnings. Keep this manual for reference. It is your guide to safe and proper operation of this generator.

Safety information appears throughout these instructions. Pay close attention to them. Below are definitions for the safety information listed throughout this manual.

**DANGER:** indicates a hazard which will cause severe personal injury, death, or substantial property damage if you ignore warning.

**WARNING:** indicates a hazard which can cause severe personal injury, death, or substantial property damage if you ignore warning.

**CAUTION:** indicates a hazard which will or can cause minor personal injury or property damage if you ignore warning.

- Gasoline presents a hazard of fire or explosion. Gasoline is flammable. Its vapor is explosive.
  - Keep fuel out of children's reach.
  - Refuel generator in a well-vented area. Do not fill fuel tank in the dark. Do not refuel while engine is running. Unhook all electrical loads and shut off engine before refueling.
  - Do not overfill fuel tank. Always allow room for fuel to expand. If you overfill tank, fuel can overflow onto hot generator. This can cause fire or explosion. After refueling, tightly close fuel tank cap.
  - Do not spill fuel. Fuel or fuel vapor may ignite. If fuel spills, make sure area is dry before starting engine.
  - Never smoke in refueling area. Never allow open flames or sparks in area.
  - Store fuel in approved container. Store fuel in a well-vented area free of open flames or sparks.
- Guard against fire hazard. Keep operation area well-vented. Keep generator at least three feet away from any object. Do not place flammable objects near generator.
  - Do not use generator where flammable vapors are present. Some vapors are heavier than air. These vapors settle in low-lying places.
  - Do not use generator in enclosed spaces. This includes motor home or RV generator compartments.
- Guard against electric shock. Generator produces high voltage. This high voltage can cause severe electric shock. Only responsible adults should use generator.
  - Properly ground generator before starting.
  - Never let anyone operate or service generator without proper instructions.
  - Avoid contact with live terminals or bare wires.
  - Do not use generator outdoors in rain or snow.
  - Do not use generator near standing water or snow.
  - Do not use if generator is wet or damp.
  - Do not use generator in highly conductive areas. These areas include metal decking and steelwork.
  - Only use grounded extension cords.
- Do not use any worn or damaged electric cords. Electric shock or damage to generator may result.
- Do not wear damp clothing or wet shoes when using generator.
- Guard against burns. Hot engine parts can cause severe injury. Use caution and remain alert when using generator.
  - Keep children and animals away from generator while it is running or hot.
  - Keep all covers and shields in place. Keep them tightly secured.
  - The muffler becomes very hot during operation. The muffler remains hot for a while after shutdown. Do not touch muffler while it is hot. Do not let muffler touch anything flammable. Let engine cool before transporting or storing.
- Have standby installation to home or building performed by a licensed electrician. Do not let anyone else wire into a utility circuit. Personal injury, equipment damage, or damage to home could occur.
- Never connect generator to any existing electrical circuits. The generator output will back-feed into the utility power line. This may electrocute a power company line repair person. Also, if generator is powering electrical circuits, the chance of an electrical fire exists.
- Battery gives off explosive gases. Keep sparks, flames, and cigarettes away. Do not remove or install battery cables when engine is cranking or running. Only service or use battery in a well-vented area.
- Battery contains sulfuric acid. Battery acid is poisonous if swallowed. Contact with skin or eyes may cause severe burns. Do not tilt generator with battery installed. Tilting could cause battery acid to spill. Wear protective clothing and face shield when servicing. Keep out of children's reach.

## SAFETY INFORMATION

### Continued

9. Only a qualified electrical service person should service and repair generator.
  - Generator produces high voltage. Use extreme caution when working on electrical parts.
  - Always remove spark plug wire from spark plug before servicing. This will prevent accidental starting.
  - When working on generator, avoid hot muffler, exhaust manifold, and engine parts. Severe burns may occur.
  - Do not work on generator when tired.
  - Use only factory approved replacement parts.
10. Store generator in a well-vented area. Make sure fuel tank is empty. Never store with fuel in tank. Vapors may reach an open flame or spark. Fire or explosion may result.
11. Never operate generator
  - if engine speed changes greatly
  - if engine misfires often
  - if powered items overheat
  - if electrical output drops
  - if it is sparking
  - if it produces smoke or flames
  - if it vibrates at high levels
  - if it has a damaged receptacle
12. Keep generator and nearby areas clean.
  - Keep generator free of oil, mud, and other foreign matter.
  - Remove anything that creates slippery areas around generator.
  - Remove oily rags and other items that create fire hazards.
  - Keep a fire extinguisher nearby. Make sure it is rated ABC by the NFPA. They are good for all uses. Consult your local fire department.
  - Keep fire extinguisher well maintained. Be familiar with its use.
13. Know how to stop engine quickly. Know how to use all controls.
14. Prolonged exposure to loud noise can cause hearing loss.
  - When working around generator, wear approved hearing protection.
  - Remember neighbors when using generator.

## PRODUCT IDENTIFICATION

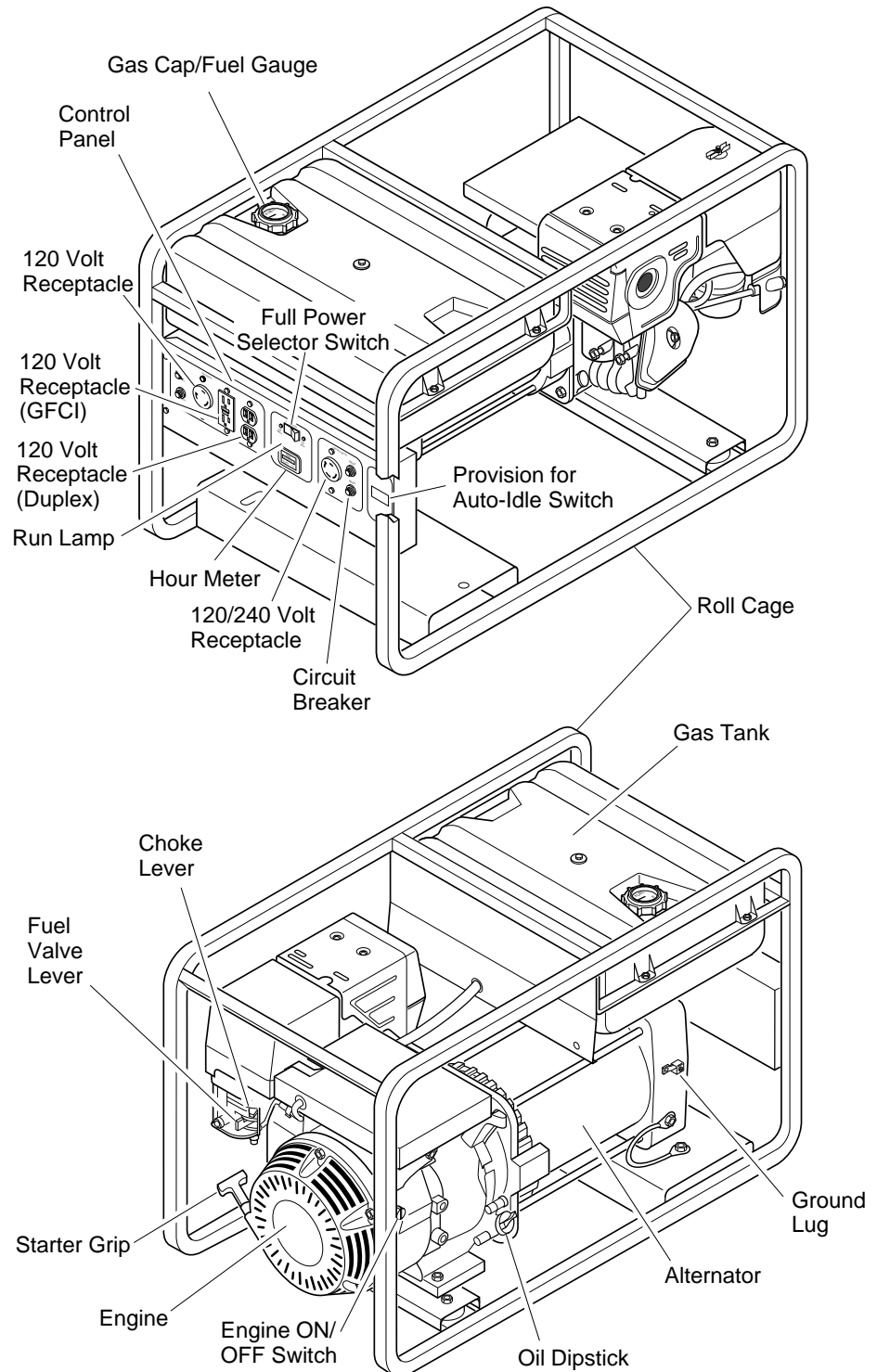

Figure 1 - Portable Generator (Model MGH4000C Shown)

# MASTER

## PORTABLE GASOLINE GENERATORS

### GENERAL INFORMATION

Master portable generators are rugged and compact. These models provide dependable, trouble-free service. The alternators are brushless with revolving fields. Honda gasoline engines provide long life under heavy use. Honda engines have overhead valves (OHV). This provides high performance with lower fuel consumption. These engines are governed to maintain engine speed of 3600 RPM under load. 3600 RPM engine speed provides 120/240V, 60 Hz power.

#### Additional Features

- Circuit breaker protection
- Spark-arresting muffler (except model MGH10000A)
- Large fuel tank
- Oil alert system
- Electric starter (models MGH5000DIE, MGH7000D, MGH7000DI, and MGH10000A only)
- 15-Amp ground fault circuit interrupter (GFCI) receptacle (Except HWI3000 Model)

### UNPACKING

1. Remove generator from carton.
2. Remove any protective packaging applied to generator for shipment.
3. Check for loose or missing parts. Check for shipping damage. If any parts are missing or damaged, promptly inform dealer where you bought generator.
4. Battery cables are supplied for models MGH5000DIE, MGH7000D, MGH7000DI, and MGH10000A only. These cables are in a separate bag inside generator carton. You must install these cables to engine. See *Battery*, page 8 for installation instructions.

### VENTILATION

**⚠ DANGER:** Use only in well-vented areas. Make sure area has plenty of free-moving, fresh, outside air. Never run generator in an enclosed or confined area. Never run generator inside occupied building. Engine exhaust contains poisonous carbon monoxide gas. Overexposure will cause loss of consciousness and will lead to death.

This generator needs cooling air to run properly. Never block free-flowing, cooling air to generator. Overheating will occur without cooling air. This will damage the generator. Keep generator at least three feet away from any object.

### DUST, DIRT, RAIN, AND SNOW

**⚠ WARNING:** Do not use generator outdoors in rain or snow. Do not use generator near standing water or snow. Do not use if generator is wet or damp. Operating generator in these conditions increases the risk of electrocution. Severe injury or death can occur.

Do not use generator in extremely dusty or dirty conditions. This will severely affect its life. Keep generator clean. Do not allow dust, dirt, rain, or snow to collect on it. Protect generator from outdoor elements.

### HIGH AND LOW TEMPERATURE OPERATION

Air temperature affects generator output. Output drops 1% for each 10° temperature rise above 60° F. Very low temperatures may make the engine hard to start. See engine owner's manual for more information.

# OWNER'S MANUAL

## SPECIFICATIONS

MODEL	HWI3000	MGH3000	MGH3000PR	MGH4000C MGH4000CI	MGH5000D MGH5000DI MGH5000DIE	MGH6000D MGH6000DI
<b>Electrical</b>						
Rated Wattage	2500	2500	2500	4000	5000	6000
Rated Amperage						
120 V	20.8	20.8	20.8	33.3	41.7	50
240 V	—	—		16.7	20.8	25
<b>Receptacle</b>						
120-V Duplex	—	—		Yes	Yes	Yes
120-V, 20-A Duplex	Yes	—		—	—	—
120-V, 15-A GFCI	No	Yes	Yes	Yes	Yes	Yes
120-V Twist-Lock	No	No	No	30 Amp	30 Amp	30 Amp
120/240-V Twist-Lock	No	No	No	20 Amp	20 Amp	20 Amp
120-V Full-Power Switch	No	No	No	Yes	Yes	Yes
120/240-V, 50-A	No	No	No	No	No	No
<b>General</b>						
Honda Engine H.P.	5.5	5.5	5.0	8	9	11
Honda Model	GX160K1VX	GX160K1VX	GC160VXA	GX240K1VA	GX270VA	GX340K1VA
Fuel Type	Gasoline	Gasoline	Gasoline	Gasoline	Gasoline	Gasoline
Fuel Tank Capacity	3.9 qt.	3.9 qt.	3.9 qt.	5 gal.	8 gal.	8 gal.
Oil Alert System	Yes	Yes	Yes	Yes	Yes	Yes
Start Method	Recoil	Recoil	Recoil	Recoil	Recoil/Elec.	Recoil
Weight (pounds)	85.5	85.5	84	139	173	191

\* Single-phase, 1.0 power factor

MODEL	MGH7000D MGH7000DI	MGH10000A
<b>Electrical</b>		
Rated Wattage	7000	10,000
Rated Amperage		
120 V	57	83.3
240 V	28.3	41.7
<b>Receptacle</b>		
120-V Duplex	Yes	Yes
120-V, 20-A Duplex	—	—
120-V, 15-A GFCI	Yes	Yes
120-V Twist-Lock	30 Amp	30 Amp
120/240-V Twist-Lock	30 Amp	30 Amp
120-V Full-Power Switch	No	No
120/240-V, 50-A	No	Yes
<b>General</b>		
Honda Engine H.P.	13	20
Honda Model	GX390K1VXE	GX620VXA3
Fuel Type	Gasoline	Gasoline
Fuel Tank Capacity	8 gal.	13 gal.
Oil Alert System	Yes	Yes
Start Method	Electric	Electric
Weight (pounds)	247	350

*Note:* Ratings apply to SAE standard conditions. Reduce ratings 3 1/2% for each 1000 feet above sea level and 1% for each 10° Fahrenheit rise above 60°F.

\* Single-phase, 1.0 power factor

# MASTER

## PORTABLE GASOLINE GENERATORS

### GENERATOR FEATURES

#### OIL ALERT SYSTEM

The oil alert system protects the engine from low oil damage. This system automatically shuts down the engine and prevents engine restarting if the oil level falls too low.

**Note:** When this happens, the engine switch remains in the ON position. The oil alert system is wired into the ON/OFF Switch.

If this system shuts down the engine, the engine will not start until you add oil. Add oil to engine (see *Engine Oil*, page 7).

**Note:** Operate generator on a level surface. If not level, the oil may flow away from the oil level sensing device. This will cause the oil alert system to shut down engine.

See engine owner's manual for more information.

Model  
MGH3000PR

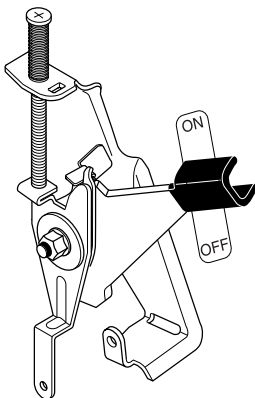

Models HWI3000,  
MGH3000, MGH4000C,  
MGH4000CI, MGH5000D,  
MGH5000DI, MGH6000D,  
and MGH6000DI



Models  
MGH5000DIE,  
MGH7000D,  
MGH7000DI, and  
MGH10000A

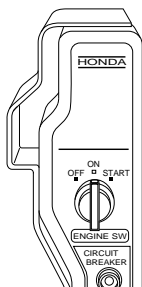

Figure 2 - Engine Switch Location

#### FULL POWER SELECTOR SWITCH

All models except HWI3000, MGH3000, MGH3000PR, MGH7000D, MGH7000DI, and MGH10000A have a full power selector switch on the control panel. The switch has two positions: 120 VOLT ONLY, and 120/240 VOLT.

**120 VOLT ONLY:** This position sends full power to the 120V receptacles only. 240V power is not available. Use this position when powering 120V items only.

**120/240 VOLT:** This position sends full power to the 120/240V receptacle. It also powers the 120V receptacles at reduced wattage capacity.

**IMPORTANT:** Do not move the full power selector switch while powering electrical items. Unplug all items before moving switch. Failure to do so can damage switch. Models HWI3000, MGH3000, MGH3000PR, MGH7000D, MGH7000DI, and MGH10000A do not have this switch. These models provide full power to all receptacles.

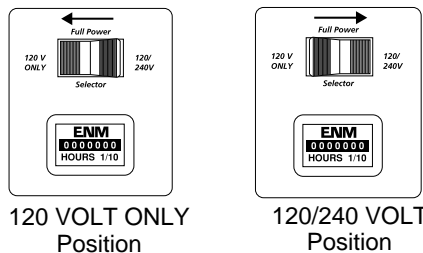

Figure 3 - Full Power Selector Switch

#### AUTO-IDLE SYSTEM

The Auto-Idle System allows the engine to idle down or run at a slower speed when the generator is not being used to supply power. The Auto-idle system can be turned ON or OFF by a rocker switch on the control panel. When the switch is in the OFF position, the engine runs at full speed all of the time. When the switch is in the ON position, the engine slows down to idle speed until an electrical load is applied. When a load is applied to the generator (an electrical item is plugged in and turned on) the engine speeds up to the preset speed required to produce the correct voltage.

**IMPORTANT:** A minimum current load of 1 Amp is required to disengage the auto idle solenoid and cause the engine to come up to speed for correct voltage. Powering items at reduced engine speed will damage generator and powered items.

#### ELECTRIC START (Models MGH5000DIE, MGH7000D, MGH7000DI, and MGH10000A)

Models MGH5000DIE, MGH7000D, MGH7000DI, and MGH10000A have electric starters. A battery is not supplied with generator. You must provide a 12-volt, 32-amp-hour battery. For more battery information, see *Battery*, page 8.

#### GROUND FAULT CIRCUIT INTERRUPTER RECEPTACLE

All models (Except HWI3000) have a 120-volt ground fault circuit interrupter (GFCI) receptacle. The GFCI receptacle is on the control panel or top cover of alternator (models MGH3000 and MGH3000PR only). The GFCI protects you against hazardous electrical shock caused when your body becomes a path through which electricity travels to reach ground. This could happen when you touch an appliance or cord that is 'live' through faulty mechanism, damp or worn insulation, etc.

When protected by the GFCI, you may still feel a shock, but the GFCI should cut it off quickly. A person in normal health should not receive serious injury. **Note:** Infants and very small children may still be affected.

#### Test Procedure

Check the GFCI receptacle every month. This insures it is working right.

1. Push black TEST button. Red RESET button should pop out. This should trip GFCI, resulting in no electrical power at receptacle. Verify this by plugging test lamp with good bulb into receptacle. If lamp does not work, GFCI receptacle is good.

**WARNING:** If RESET button does not pop out, do not use the GFCI receptacle. Contact a qualified electrician for repairs.

## GENERATOR FEATURES

### Continued

- If the GFCI receptacle tests okay, restore power by pushing the RESET button back in. The test lamp should work at this time. **IMPORTANT:** You must press the RESET button firmly and fully. It should lock into place. If the GFCI does not lock into place, do not use receptacle. Contact a qualified electrician for repairs.

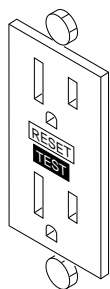

Figure 4 - GFCI Receptacle

## ENGINE CIRCUIT BREAKER (Models MGH5000DIE, MGH7000D, MGH7000DI, and MGH10000A)

This circuit breaker, or fuse, protects the battery charging circuit. A short circuit will trip the circuit breaker. The circuit breaker will also trip if you install battery wrong. Push circuit breaker button to reset. On Model MGH10000A, the fuse is located inside of the Keyswitch box.

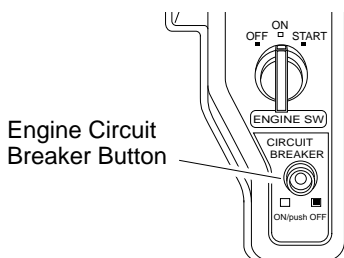

Figure 5 - Engine Circuit Breaker

## RECEPTACLE CIRCUIT BREAKER

The circuit breakers protect the receptacles and alternator. Overloading generator will trip circuit breaker. A short circuit in item being powered will also trip breaker. If this occurs, unplug electrical load from receptacle. Let circuit breaker cool down. Push circuit breaker button to reset.

Electric motors need higher starting current. They require up to three-times their rated wattage to start. The starting current needed may be too high. This can cause nuisance circuit breaker tripping. To help prevent this, start electric motors first. Connect additional items to generator after starting motors. If this continues to happen, reduce the total generator load.



Figure 6 - Receptacle Circuit Breaker Button

**Note:** High ambient temperature will cause nuisance tripping.

## ENGINE OIL

We ship the generator without oil in the engine crankcase. You must add oil before starting engine. See engine owner's manual for specific oil type.

## CHECKING OIL LEVEL AND ADDING OIL

Follow steps below to check oil level. Make sure engine is level and stopped.

- Remove dipstick (see Figure 7). Wipe dipstick clean.
- Insert dipstick into oil filler neck. Do not screw it in. Oil level should be at top of filler neck. Oil should cover most of dipstick. For Model MGH10000A only, the oil should be between the two dots on dipstick.
- If level is low, fill to top of oil filler neck (see Figure 7). For Model MGH10000A only, fill to top dot on dipstick. Only use oil recommended in engine owner's manual.

**Note:** If oil level is too low, oil alert system will shutdown engine and prevent engine from restarting.

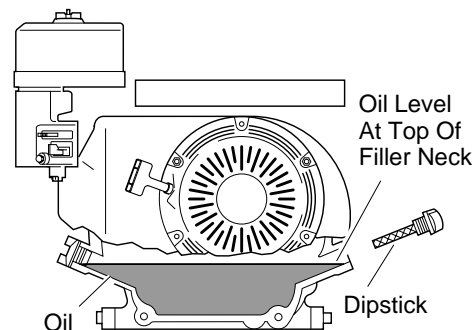

Figure 7 - Checking Oil Level (Model MGH4000C Shown)

## FUEL

**WARNING:** Gasoline presents a hazard of fire or explosion. Gasoline is flammable. Its vapor is explosive.

- Keep fuel out of children's reach.
- Refuel generator in a well-vented area. Do not fill fuel tank in the dark. Do not refuel while engine is running. Unhook all electrical loads and shut off engine before refueling.
- Do not overfill fuel tank. Always allow room for fuel to expand. If you overfill tank, fuel can overflow onto hot engine. This can cause fire or explosion. After refueling, tightly close fuel tank cap.
- Do not spill fuel. Fuel or fuel vapor may ignite. If fuel spills, make sure area is dry before starting engine.
- Never smoke in refueling area. Never allow open flames or sparks in area.
- Store fuel in approved container. Store fuel in a well-vented area free of open flames or sparks.

Use clean, fresh, unleaded gasoline. Use gasoline with octane rating of 86 or higher. Service station gasoline pumps should display the octane rating. Using gasoline with lower octane level could damage engine. Avoid getting dirt, dust, or water in fuel tank. Do not mix oil with gasoline.

See engine owner's manual for more information.

# MASTER

## PORTABLE GASOLINE GENERATORS

### HANDLES AND TOP COVER (Model MGH10000A)

Follow the steps below to attach the handles and top cover to Model MGH10000A:

1. Remove the two bolts, lock nuts, and washers holding side panels to control panel end of roll cage. Insert bolts with washers through two holes in the handle and then back through roll cage and side screen panels (See Figure 8). Tighten the lock nuts against the side screen panels.
2. Place top cover on top of generator roll cage with notch on control panel side. Use four #8 sems screws provided to attach cover to roll cage (See Figure 9).

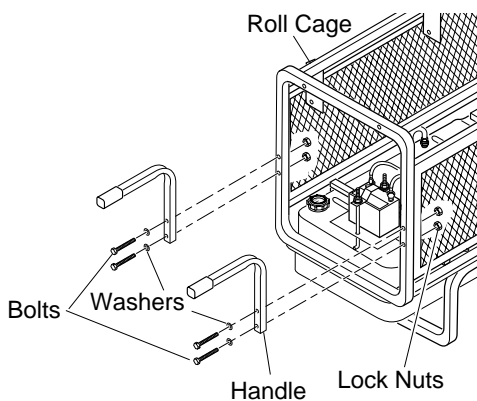

Figure 8 – Attaching Handles to Roll Cage

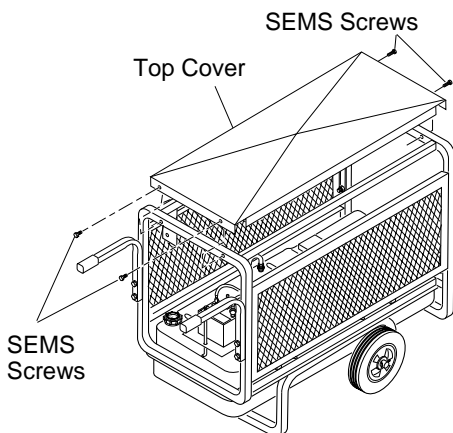

Figure 9 – Attaching Top Cover to Roll Cage

### BATTERY

(Models MGH5000DIE, MGH7000D, MGH7000DI, and MGH10000A)

**⚠ WARNING: Battery gives off explosive gases. Keep sparks, flames, and cigarettes away. Do not remove or install battery cables when engine is cranking or running. Only service or use battery in a well-vented area.**

**⚠ WARNING: Battery contains sulfuric acid. Contact with skin or eyes may cause severe burns. Do not tilt generator with battery installed. Tilting could cause battery acid to spill. Wear protective clothing and face shield when servicing. Keep out of children's reach.**

- If battery acid gets on your skin, wash with water.
- If battery acid gets in your eyes, flush with water at least 15 minutes. Call a doctor at once. Battery acid is poisonous.
- If swallowed, drink large amounts of water or milk. Follow with milk of magnesia or vegetable oil. Call a doctor at once.

**⚠ CAUTION: If you remove battery, insulate the red, positive (+) battery cable terminal. Insulate with electrical tape. Exposed terminal may spark when generator runs.**

**IMPORTANT:** Make sure battery connections are the correct polarity. Electric start generators use negative ground, 12-volt DC starting system.

Models MGH5000DIE, MGH7000D, MGH7000DI, and MGH10000A have an electric starter. A battery is not supplied with generator. You must provide a 12-volt, 32-amp-hour battery. The positive and negative battery cables are supplied with generator. You must install these cables before mounting battery.

Always wear safety glasses when working with battery. Make sure battery terminals are clean. Make sure cable connections are tight.

Always shut down engine before removing or attaching battery cables. Always remove the negative (–) cable first. Always attach negative (–) cable last.

### INSTALLING BATTERY CABLES TO ENGINE

1. Attach the red, positive (+) battery cable to the starter solenoid on engine (see Figure 10). The starter solenoid is located directly above the starter on Model MGH10000A. This cable is factory installed.

**⚠ CAUTION: Do not over tighten positive terminal on starter solenoid. Positive terminal could rotate and cut into negative terminal, causing a short.**

2. Attach the black, negative (–) battery cable to the engine block. Use the bolt, nut, and two washers provided with the battery cables. Use long mounting hole on opposite side of engine from starter solenoid. Attach cable as shown in Figure 11.

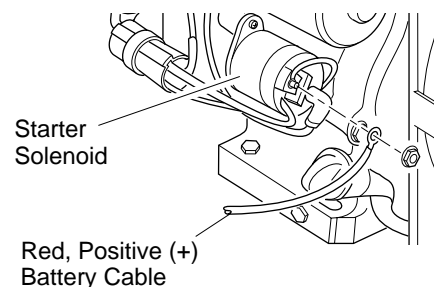

Figure 10 - Connecting Red, Positive (+) Battery Cable to Engine Starter Solenoid (Model MGH7000D Shown)

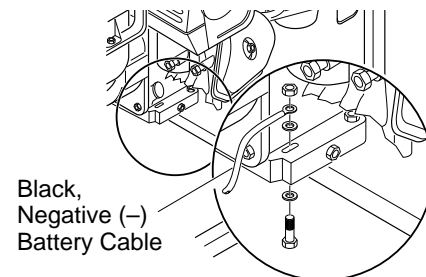

Figure 11 - Connecting Black, Negative (-) Battery Cable to Engine Block (Model MGH7000D Shown)



# OWNER'S MANUAL

## BATTERY

*Continued*

### MOUNTING BATTERY TO GENERATOR

1. Secure battery to generator by battery hold-down system. This system consists of the battery mounting bracket, hook bolts, and nut (see Figure 12).

*Note:* Model MGH10000A battery is located on opposite side as shown (see Figure 13).

2. Locate the red, positive (+) battery cable from starter solenoid. Connect it to the positive (+) battery terminal (see Figures 14 and 15).
3. Locate the black, negative (-) battery cable attached to engine block. Connect it to the negative (-) battery terminal (see Figures 14 and 15).
4. Check battery before starting engine. Make sure fluid levels are full. Make sure battery is charged.

See engine owner's manual for more information.

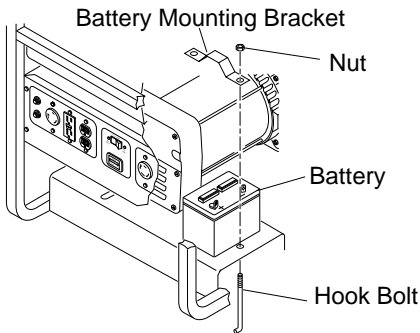

**Figure 12 - Battery Hold-Down System (Model MGH7000D Shown)**

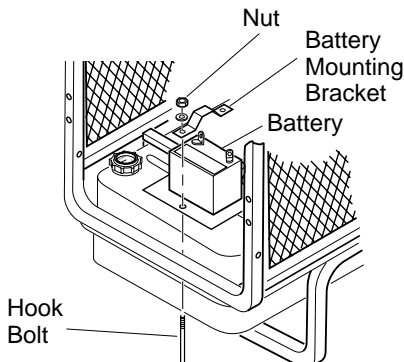

**Figure 13 - Battery Hold-Down System (Model MGH10000A Shown)**

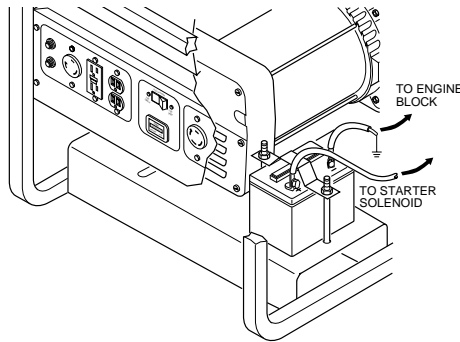

**Figure 14 - Connecting Positive and Negative Cables to Battery (Model MGH7000D Shown)**

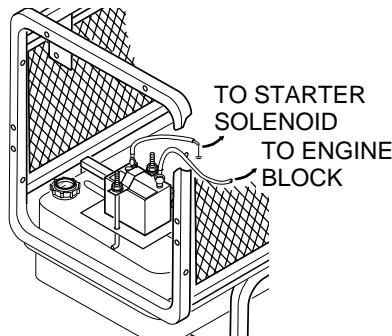

**Figure 15 - Connecting Positive and Negative Cables to Battery (Model MGH10000A Shown)**

## EXTENSION CORDS

Only use grounded extension cords. Be sure to use extension cord with proper wire gauge size. See chart below.

### Recommended Minimum Wire Gauges (AWG) for Extension Cords

Ampere Load	AWG for Length of Cord in Feet		
	50'	100'	150'
2	18	18	18
3	18	18	18
4	16	16	16
5	16	16	16
6	16	16	14
8	16	14	12
10	16	14	12
12	14	14	12
14	14	12	10
16	12	12	10
20	10	10	8

## GENERATOR GROUNDING

**⚠ WARNING:** You must properly earth-ground generator before starting. This will help guard against deadly electric shock. Only use grounded plugs with generator. Only use grounded extension cords. Only use three-wire or double-insulated power tools.

Grounding generator helps prevent electric shock from a ground fault condition. Locate ground lug on end of generator housing (see Figure 16). Attach a #10 stranded-copper ground wire to ground lug. Drive grounding point into ground. Grounding point can be a stake, grounding rod, or pipe. Grounding point should be copper or brass. Attach ground wire to grounding point. You must supply the ground wire and grounding point. These do not come with generator. Follow the *National Electrical Code* and all state and local codes. Consult your power company or a licensed electrician.

**⚠ WARNING:** For a grounding point, do not use metal pipe being used to carry combustible materials or gases.

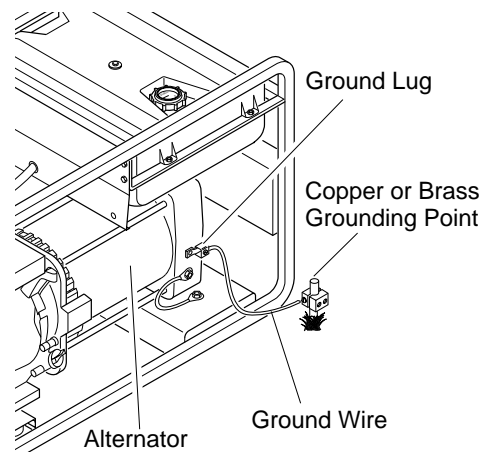

**Figure 16 - Grounding Generator (Model MGH4000C Shown)**

# MASTER

## PORTABLE GASOLINE GENERATORS

### STANDBY INSTALLATION TO HOME OR BUILDING

**⚠ WARNING: Have standby installation performed by a skilled, licensed electrician. Do not let anyone else wire into a utility circuit. Personal injury, equipment damage, or damage to home could occur.**

**IMPORTANT:** This generator will not power your entire home. Most home utility electric service is more than 60 amps. This will exceed generator output. Only power needed items during a power outage. Make sure total wattage of electrical load does not exceed rated wattage of generator.

You may need to use this generator as a standby power source. During a power outage, the generator will power selected items in a building. Have generator and additional wiring installed by a skilled, licensed electrician. This is not a do-it-yourself job. Follow all local codes.

**⚠ WARNING: The electrician must install a double-throw transfer switch. This isolates existing electrical circuits from the utility power line. If not isolated, generator output will back-feed into utility power line. This may electrocute a power company line repair person.**

### DETERMINING ELECTRICAL LOAD FOR GENERATOR

You must decide what electrical load your generator can power. Do this before using generator. Use the following four-step method. It will help you select a load that is not too large. Make sure total wattage of all electrical loads does not exceed rated wattage of generator. For rated wattage of your generator, see *Specifications*, page 5. Electric motors present a special problem when figuring load. Read Step 3 carefully.

1. Make two lists of items you want powered by generator. List all motors and motor powered appliances in one. List all lights, small appliances, etc. in the other. For standby service to home or building, only include items you must power.
2. Enter running watts of each item except motors. The light bulb or appliance nameplate lists its wattage. Remember, 1KW = 1000 watts. *Note:* The nameplate may not list wattage. It may only list volts and amps. The formula for finding wattage is: Volts x Amps = Watts. For example: An appliance nameplate states 3 amps at 120 volts. 3 amps x 120 volts = 360 watts.
3. Electric motors present a special problem. They require up to three-times their rated wattage to start. Chart 2, below, shows starting watts for differ-

ent size motors. For example: an electric motor nameplate states 5 amps at 120 volts. 5 amps x 120 volts = 600 watts running. Multiply this figure by 3. This will show the starting watts needed. 600 watts x 3 = 1800 watts to start. When figuring the generator load for motors, you must use the starting watts figure. Do not use the running watts figure. *Note:* Some motors require nearly the same wattage to run as to start. These items include saws, drills, hair dryers, and food mixers. See Chart 1 for typical appliance wattage examples.

4. Add watts and starting watts of all items. This total must not be larger than the rated wattage of your generator. It is a good idea to have up to 25% extra capacity for future needs or extra equipment.

**Chart 1 - Typical Electric Appliance Wattages**

Equipment	Running Watts	Starting Watts	Equipment	Running Watts	Starting Watts
Light bulb (100W)	100	100	1/2" Drill	1000	1250
Radio	150	150	Toaster	1200	1200
Fan	200	600	Coffee maker	1200	1200
Television	400	400	Skillet	1200	1200
Furnace fan (1/3 hp) with blower	600	1800	14" Chain saw	1200	1500
Vacuum cleaner	600	750	Water well pump (1/2 hp)	1000	3000
Sump pump (1/3 hp)	700	2100	Hot plate/range (per burner)	1500	1500
Refrigerator/freezer	800	2400	10" Table saw	2000	6000
6" Circular saw	800	1000	Water heater (storage-type)	5000	5000
Floodlight	1000	1000			

**Chart 2**

Motor HP Rating	Approximate Running Watts	Approximate Starting Watts*			
		Universal Motors (small appliance)	Repulsion Induction Motors	Capacitor Motors	Split Phase Motors
1/8	275	400	600	850	1200
1/4	400	500	850	1050	1700
1/3	450	600	975	1350	1950
1/2	600	750	1300	1800	2600
3/4	850	1000	1900	2600	x
1	1000	1250	2300	3000	x
1 1/2	1600	1750	3200	4200	x
2	2000	2350	3900	5100	x
3	3000	x	5200	6800	x

\* - Always use starting watts, not running watts, when figuring correct electrical load.  
 x - Motors of higher horsepower are not generally used.

# OWNER'S MANUAL

## OPERATION

### GENERAL INFORMATION

This generator is not large enough to power your entire home. Do not connect generator to any existing electrical circuits. Plug items directly into generator receptacles. Do not exceed amperage rating of receptacles. Only use grounded cords.

**⚠ DANGER:** Use only in well-vented areas. Make sure area has plenty of free-moving, fresh, outside air. Never run generator in an enclosed or confined area. Never run generator inside occupied building. Engine exhaust contains poisonous carbon monoxide gas. Overexposure will cause loss of consciousness and will lead to death.

**⚠ DANGER:** Never connect generator to any existing electrical circuits. The generator output will back-feed into the utility power line. This may electrocute a power company line repair person. Also, if generator is powering electrical circuits, the chance of an electrical fire exists.

*Note:* We supply the engine owner's manual with generator. Refer to that manual for questions concerning engine operation.

### USING RECEPTACLE

*Note:* Do not exceed amperage rating of receptacles. Exceeding rating will trip receptacle circuit breaker.

Use receptacles properly. Improper use could damage generator. Use only grounded extension cords. Power only grounded or double-insulated items. Do not overload receptacles. All generators (except models HWI3000, MGH3000, and MGH3000PR) have the following receptacles (see Figure 17):

- 120V, 15-amp GFCI duplex receptacle
- 120V, 30-amp twist-lock receptacle
- 120/240V, 20 or 30-amp twist-lock receptacle
- 120V, 15-amp duplex receptacle

Model MGH10000A also has a 120/240V, 50-amp receptacle (see Figure 17).

Model HWI3000 has only the 120V, 20-amp duplex receptacle.

Models MGH3000 and MGH3000PR have only the 120V, 15-amp GFCI duplex receptacle.

120V, 15-Amp GFCI Duplex

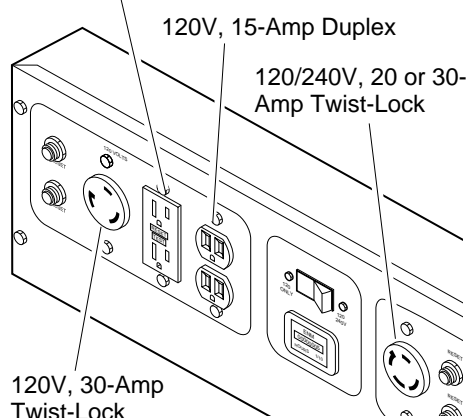

120V, 30-Amp Twist-Lock

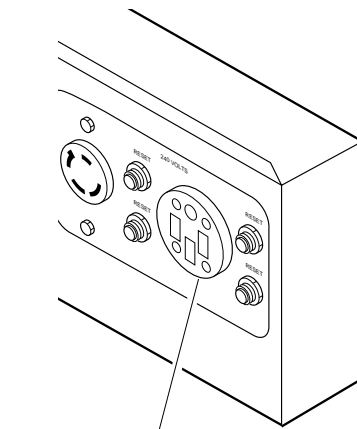

120/240V, 50-Amp (Model MGH10000A only)

Figure 17 - Receptacle Locations

### POWER CORD AND PLUG REQUIREMENTS

120V, 30-amp twist-lock receptacle

- NEMA L5-30P plug
- Three-wire, 30-amp cord

120/240V, 20 or 30-amp twist-lock receptacle

- NEMA L14-20P (20-amp) or L14-30P (30-amp) plug
- Four-wire, 20-amp or 30-amp cord

120/240V, 50-amp receptacle

- NEMA L14-50P
- Four-wire, 50-amp cord

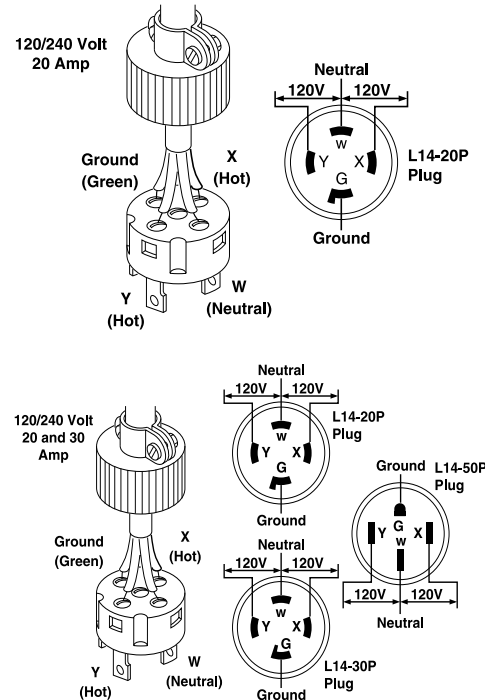

Figure 18 - Cord and Plug Configurations

# MASTER

## PORTABLE GASOLINE GENERATORS

### OPERATION

#### Continued

#### PRESTART

Operate generator on a firm, dry, and clean surface. The surface must be level. Protect generator from heavy dust, sand, dirt, rain, or snow. Do not locate generator near standing water and snow. Make sure area is well-ventilated.

**WARNING:** Only responsible adults should use generator. Never let anyone operate generator without proper instructions.

*Note:* If oil level is too low, oil alert system will keep engine from starting (see *Oil Alert System*, page 6). Make sure oil level is full before starting. See *Engine Oil*, page 7.

Before starting the engine, disconnect all electric loads from generator.

#### STARTING

**IMPORTANT:** The engine speed is preset. The throttle is locked in preset position. Do not adjust throttle. Preset position lets engine run at 3600 RPM under load. The engine must maintain 3600 RPM for generator to create correct voltage. Running engine at lower speeds will damage generator and powered items.

**IMPORTANT:** Never start generator with electrical loads connected. Start engine before adding electrical loads.

1. Make sure gasoline tank is full. See *Fuel*, page 7 for fuel information.
2. Move fuel valve lever to the ON position except on Model MGH3000PR (see Figure 19).
3. Move choke lever fully to the left for all models except MGH3000PR or MGH10000A (see Figure 19). Pull choke rod out for Model MGH3000PR (see Figure 20) or choke button out for Model MGH10000A (see Figure 21). This closes the choke.

*Note:* You may not need to close choke if engine is warm or air temperature is high.

4. Start the engine.

#### A. Recoil Starter

Move engine lever or turn engine switch to the ON position (see Figures 22 and 23). Remove slack from starter rope by lightly pulling starter grip. Next, pull starter rope briskly.

**IMPORTANT:** Do not let starter grip snap back against engine. Return it gently. This will prevent damage to starter.

*Note:* If engine does not start, check the oil in the crankcase. Add oil as necessary. Be sure engine is on a level surface. See *Oil Alert System*, page 6.

#### B. Electric Starter (Models MGH5000DIE, MGH7000D, MGH7000DI, and MGH10000A Only)

Turn the engine switch to the START position (see Figure 24, page 13). Hold it there until engine starts. When engine starts, let switch return to the ON position.

**IMPORTANT:** Do not use electric starter more than five seconds. Starter motor damage may occur. If engine fails to start, release the switch and wait ten seconds. After ten seconds, try starting again.

*Note:* If engine does not start, check the oil in the crankcase. Add oil as necessary. Be sure engine is on a level surface. See *Oil Alert System*, page 6.

5. As engine warms up, slowly move choke lever fully to the right (see Figure 25, page 13). This opens the choke. On Model MGH10000A, the choke will automatically open.

Choke Lever (Closed Position)

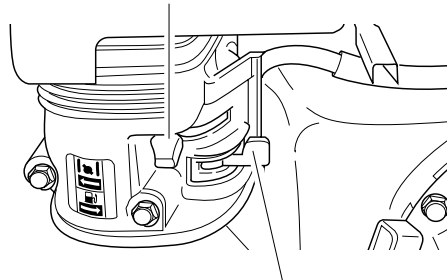

Figure 19 - Fuel Valve Lever On, Choke Lever Closed (Model MGH4000C Shown)

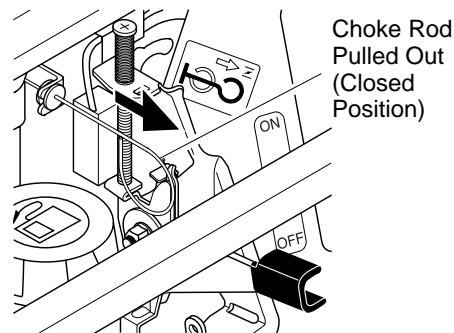

Figure 20 - Choke Rod Closed (Model MGH3000PR Only)

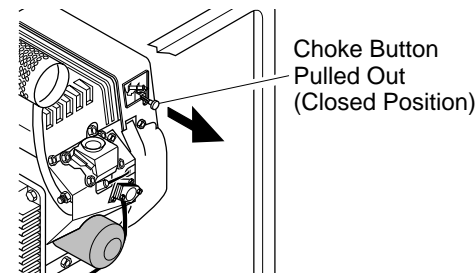

Figure 21 - Choke Button Closed (Model MGH10000A Only)

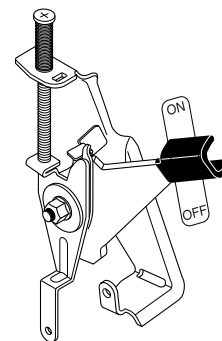

Figure 22 - Engine Lever In ON Position (Model MGH3000PR Only)

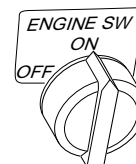

Figure 23 - Engine Switch In ON Position (All Models Except MGH5000DIE, MGH7000D, MGH10000A, and MGH3000PR)

## OPERATION

Continued

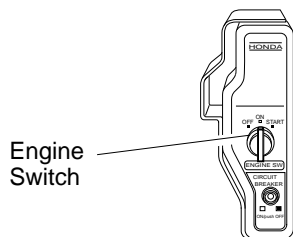

Figure 24 - Engine Switch (Models MGH5000DIE, MGH7000D, MGH7000DI, and MGH10000A Only)

Choke Lever (Open Position)

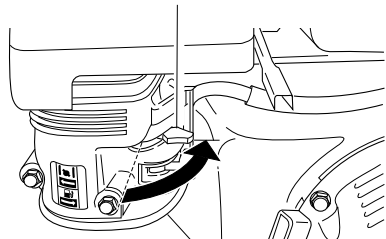

Figure 25 - Choke Lever Opened (Model MGH7000D Shown)

## AUTO-IDLE OPERATION

**IMPORTANT:** Never start engine with electrical loads connected. Start engine before adding electrical loads.

1. If engine is cold, turn the Auto-Idle switch OFF (see Figure 26).
2. Start engine. Allow engine to warm up with no load for five minutes.
3. Turn Auto-Idle switch ON. Engine will slow to idle speed. Engine idle speed is preset. Idle speed adjustment should not be necessary.
4. Operate generator according to specifications outlined in owner's manual.
5. Engine will automatically increase to normal operating speed when you plug load into any generator outlet.

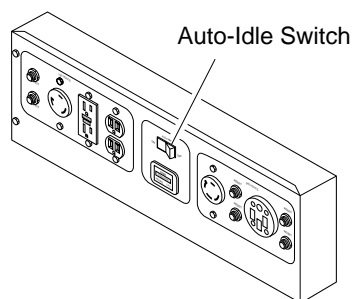

Figure 26 - Control Panel

**Note:** The 250 Volt/50 Amp receptacle is not connected through the Auto-Idle circuit. The Auto-Idle switch must be turned off to get full power out of this receptacle (see Figure 26).

6. The Auto-Idle system should be turned OFF when generator is shut down.

## Adjusting the Idle Speed

**IMPORTANT:** Adjust the idle speed only:

- If the idle speed becomes too high.
  - If the engine idle speed will not regulate (engine idles and speeds up again and again).
1. Turn Auto-Idle switch OFF. Start engine. Allow engine to warm up with no load for five minutes.

**WARNING:** Always set the idle speed before turning on the Auto-Idle. If idle speed is not set, the larger resistor on the control board may become hot. Heat from the resistor may damage the protective coating on the control board.

2. Remove engine linkage cover (Models MGH4000CI, MGH5000DI, MGH5000DIE, MGH6000DI, and MGH7000DI).
3. Push plunger into solenoid body to manually engage solenoid and set idle speed.
4. Loosen the M8 nut that holds the solenoid mounting bracket to the generator (Models MGH4000CI, MGH5000DI, MGH5000DIE, MGH6000DI, and MGH7000DI. See Figure 27). Do not loosen bolt that holds the solenoid mounting bracket to the generator on Model MGH10000A (see Figure 28).
5. Slowly pull solenoid bracket away from engine (on Model MGH10000A this will require bending the bracket slightly).
6. With a volt meter, check the no-load output voltage at the 120-volt duplex receptacle. At proper idle speed (2680 minimum RPM) the meter should read 50-60 volts. Lower settings will cause the Auto-Idle to not operate properly.
7. After reaching proper idle speed, tighten M8 nut to secure solenoid mounting bracket (Models MGH4000CI, MGH5000DI, MGH5000DIE, MGH6000DI, and MGH7000DI (see Figure 27).

8. Turn Auto-Idle switch ON. Make sure solenoid is engaged. When engaged, the plunger is pulled back into the solenoid.
9. If the engine speed is too slow, the engine will want to "hunt" or speed up and slow down repeatedly. When this occurs, increase engine speed by adjusting throttle stop screw on carburetor (refer to Carburetor Adjustment in Honda Engine Manual).
10. Replace the engine linkage cover (Models MGH4000CI, MGH5000DI, MGH5000DIE, MGH6000DI, and MGH7000DI).

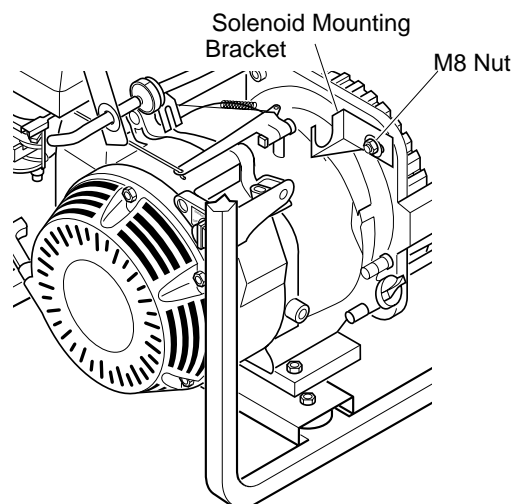

Figure 27 - Solenoid Bracket Location, Models MGH4000CI, MGH5000DI, MGH5000DIE, MGH6000DI, and MGH7000D Only

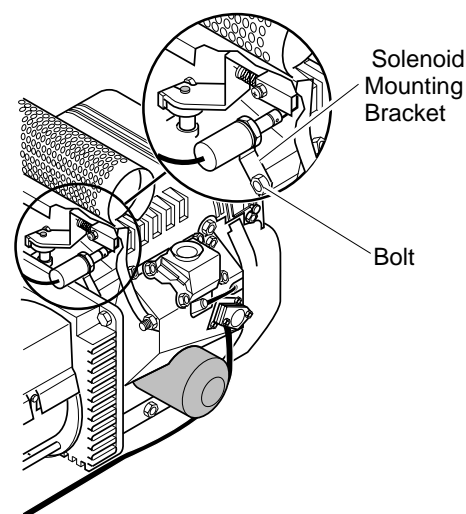

Figure 28 - Solenoid Bracket Location, Model MGH10000A Only

# MASTER

## PORTABLE GASOLINE GENERATORS

### OPERATION

*Continued*

#### HIGH ALTITUDE OPERATION

This generator will not perform well at high altitudes without proper adjustment. See engine owner's manual for details.

#### ADDING ELECTRICAL LOADS

**IMPORTANT:** Do not overload generator. Make sure total wattage of all electrical loads does not exceed rated wattage of generator. Overloading may shorten generator life. It could also cause internal damage to generator. Overloading will trip circuit breaker.

**IMPORTANT:** (All models except HWI3000, MGH3000, MGH3000PR, MGH7000D, MGH7000DI, and MGH10000A) Keep full power selector switch in the 120 VOLT ONLY position if only powering 120V items. Only move switch to 120/240 VOLT position if powering 240V items.

1. Check items to be powered. Their nameplate lists their wattage ratings.

**Note:** The wattage ratings for some electrical motors are misleading. They may require up to three-times their rated wattage to start. You must figure total electrical load wattage. Make sure total wattage of all electrical loads does not exceed rated wattage of generator. See *Determining Electrical Load For Generator*, page 10.

2. Start engine. Let engine reach full speed.
3. Connect electrical loads one at a time. If the load consists of electric motors, start them first. Always start the largest first. Start each motor individually.

#### DISCONNECTING ELECTRIC LOADS

Remove electrical loads one at a time. Remove voltage sensitive items first. Voltage sensitive items include TVs, VCRs, and other home electronic items.

### STOPPING ENGINE

**IMPORTANT:** The engine speed is preset. The throttle is locked in preset position. Do not adjust throttle.

Follow the steps below to stop engine.

1. Remove all electrical loads from generator (see *Disconnecting Electrical Loads*). Remove electrical loads one at a time.
2. Let engine run for two or three minutes after removing electrical loads. This lets engine cool slightly.
3. Turn engine switch to the OFF position (see Figure 29).
4. Turn fuel valve lever off except on Model MGH3000PR. Do this by moving valve lever fully to the left (see Figure 30).

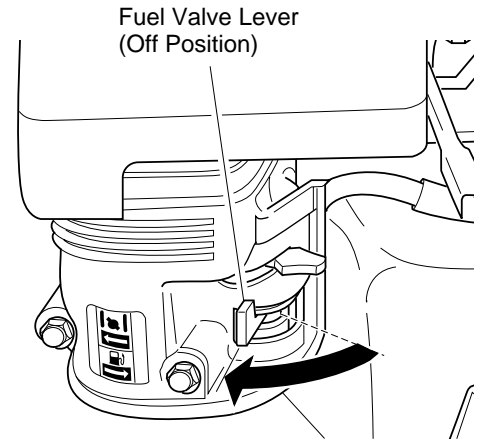
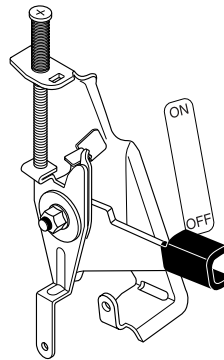
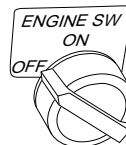

Figure 30 - Fuel Valve Lever Off (Model MGH7000D Shown)

Model MGH3000PR



Models HWI3000, MGH3000, MGH4000C, MGH4000CI, MGH5000D, MGH5000DI, MGH6000D and MGH6000DI



Models MGH5000DIE, MGH7000D, MGH7000DI, and MGH10000A

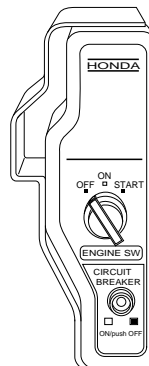

Figure 29 - Engine Switch In OFF Position

# OWNER'S MANUAL

## MAINTENANCE AND REPAIRS

**⚠ WARNING:** Only a qualified electrical service person should service and repair the alternator on this generator. Use only factory approved replacement parts.

**⚠ CAUTION:** The engine speed is preset. The throttle is locked in preset position. Do not adjust throttle. Preset position lets engine run at 3600 RPM under load. The engine must maintain 3600 RPM for generator to create correct voltage. Running engine at lower speeds will damage generator and powered items.

**⚠ CAUTION:** Shut off generator before performing maintenance.

**IMPORTANT:** Keep generator level when servicing. Never turn generator upside down or stand it on end to service.

**Note:** We supply the engine owner's manual with generator. Refer to that manual for questions concerning engine maintenance and repairs.

Non-engine parts require little maintenance. Keep generator clean. Use a damp cloth to clean outside surfaces. Never use water to clean generator. Water can cause damage to internal parts. Use vacuum to clean air inlet and outlet louvers of alternator.

## STORAGE

**⚠ WARNING:** Remove all fuel from fuel tank before storing generator. Store fuel in approved container. Store fuel in a well-vented area free of open flames or sparks.

**⚠ WARNING:** The muffler becomes very hot during operation. The muffler remains hot for a while after shutdown. Let engine cool before storing.

**IMPORTANT:** Keep generator level while in storage. Never store generator upside down or standing on end.

**Note:** We supply the engine owner's manual with generator. Refer to that manual for questions concerning engine storage.

Use a fuel additive, such as STA-BIL® or an equivalent, when storing generator with fuel in fuel tank. This will minimize fuel gum deposits from forming in engine.

Cover and store generator in a clean, dry place. Do not expose generator to extreme high or low temperatures during storage.

## TROUBLESHOOTING

**Note:** For additional help, visit DESA International's technical service web site at [www.desatech.com](http://www.desatech.com).

**⚠ WARNING:** Only a qualified electrical service person should service and repair generator. Use only factory approved replacement parts.

**Note:** See engine owner's manual for engine troubleshooting.

OBSERVED PROBLEM	POSSIBLE CAUSE	REMEDY
No voltage when starting generator with no electrical load	<ol style="list-style-type: none"> <li>1. Defective capacitor</li> <li>2. Winding short circuit or loose connections</li> <li>3. Defective rotor diode</li> <li>4. Loss of residual magnetism</li> </ol>	<ol style="list-style-type: none"> <li>1. Replace capacitor</li> <li>2. Check resistance of coils (see <i>Electrical Component Specifications</i>, page 15)</li> <li>3. Replace both diodes on rotor</li> <li>4. Apply 12-volt battery to capacitor terminals for 2-3 seconds</li> </ol>
Voltage is less than normal voltage with no electrical load	<ol style="list-style-type: none"> <li>1. Engine speed too low</li> <li>2. Defective rotor diode</li> <li>3. Partial short circuit in winding</li> <li>4. Defective capacitor</li> </ol>	<ol style="list-style-type: none"> <li>1. Set engine speed to 3720 RPM (62 Hz) with no load</li> <li>2. Replace both diodes on rotor</li> <li>3. Check resistance of coils (see <i>Electrical Component Specifications</i>, page 15)</li> <li>4. Replace capacitor</li> </ol>
Voltmeter reading more than 10% high with no electrical load	<ol style="list-style-type: none"> <li>1. Engine speed too high</li> </ol>	<ol style="list-style-type: none"> <li>1. Set engine speed to 3720 RPM (62 Hz) with no load</li> </ol>
Voltmeter reading correct with no electrical load, but more than 10% low when electrical load is added	<ol style="list-style-type: none"> <li>1. Defective rotor diode</li> <li>2. Electrical load too high</li> <li>3. Engine not running properly</li> </ol>	<ol style="list-style-type: none"> <li>1. Replace both diodes on rotor</li> <li>2. Do not overload generator</li> <li>3. Contact an authorized engine service center</li> </ol>

[www.desatech.com](http://www.desatech.com)

# MASTER

## PORTABLE GASOLINE GENERATORS

### ELECTRICAL COMPONENT SPECIFICATIONS

Model	Resistance in Ohms				Capacitor, MFD 450 Volt	Diodes (2) 800 Volt
	Stator Main Winding *	Stator Auxiliary Winding $\Delta$	Rotor Primary Winding $\dagger$	Rotor Secondary Winding $\dagger$		
HWI3000	1.6	5.9	6.9	1.33	16	6 Amp
MGH3000, MGH3000PR	1.6	5.9	6.9	1.33	16	6 Amp
MGH4000C, MGH4000CI	0.71	2.17	0.54	2.07	40	70 Amp
MGH5000D, MGH5000DI	0.54	1.38	0.61	2.29	50	70 Amp
MGH5000DIE	0.54	1.38	0.61	2.29	50	70 Amp
MGH6000D, MGH6000DI	0.37	1.01	0.68	2.57	60	70 Amp
MGH7000D, MGH7000DI	0.28	0.78	0.77	2.9	70	70 Amp
MGH10000A	0.40	0.90	0.37	0.50	80	70 Amp

\* Connect T2 (green) and T3 (black). Measure resistance between T1 (red) and T4 (yellow).

$\Delta$  Resistance between brown and white leads.

$\dagger$  Remove diodes to check resistance.

### WIRING DIAGRAMS

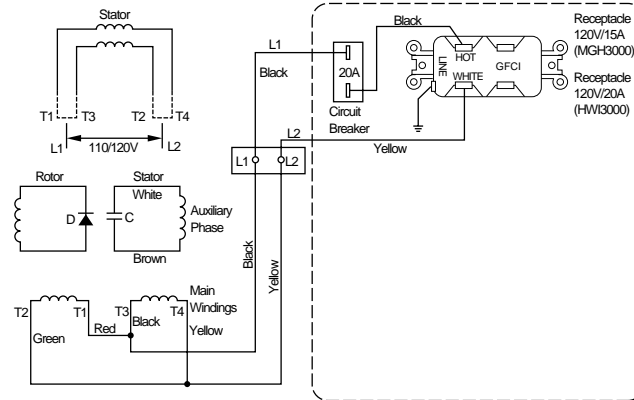

Figure 31 - Wiring Diagram, Models HWI3000, MGH3000, and MGH3000PR

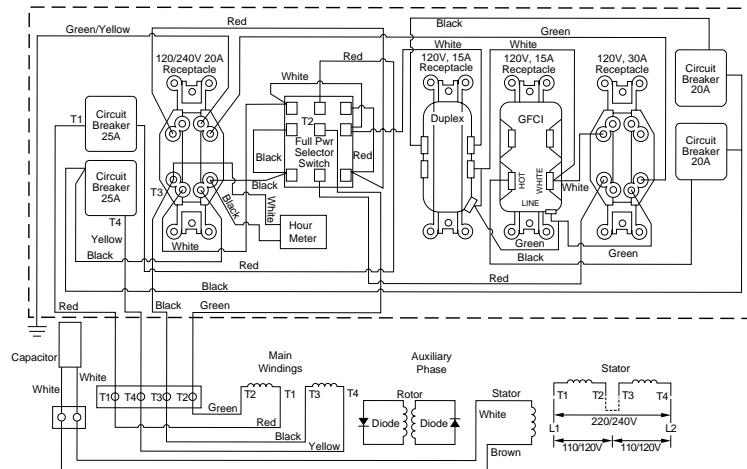

Figure 32 - Wiring Diagram, Models MGH4000C, MGH5000D, and MGH6000D



# OWNER'S MANUAL

## WIRING DIAGRAMS

Continued

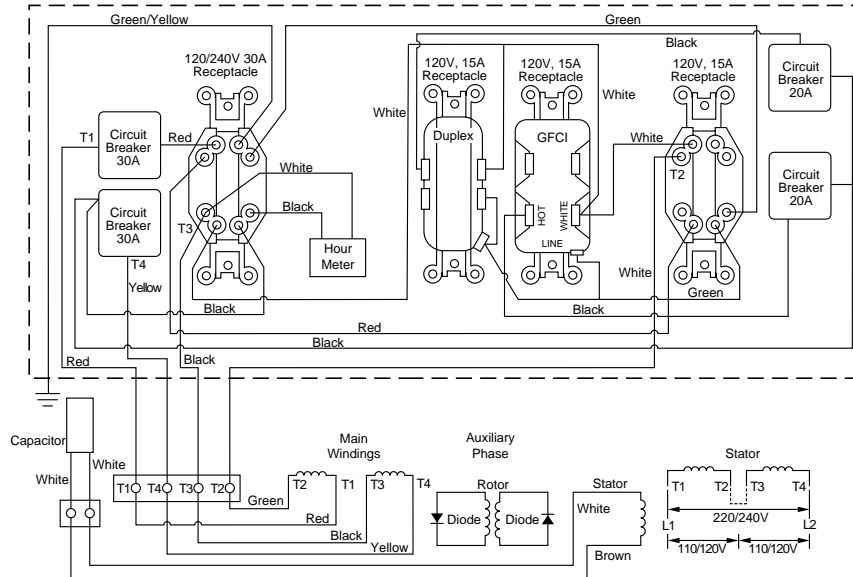

Figure 33 - Wiring Diagram, Model MGH7000D

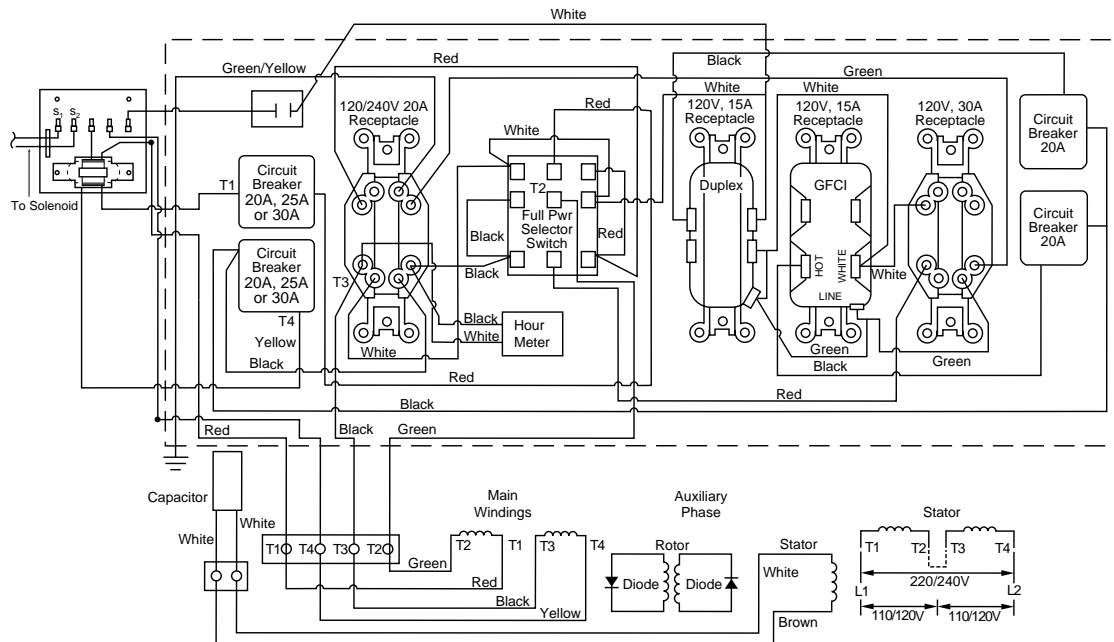

Figure 34 - Wiring Diagram, Models MGH4000CI, MGH5000DI, MGH5000DIE, and MGH6000DI

Continued

# MASTER

## PORTABLE GASOLINE GENERATORS

### WIRING DIAGRAMS

Continued

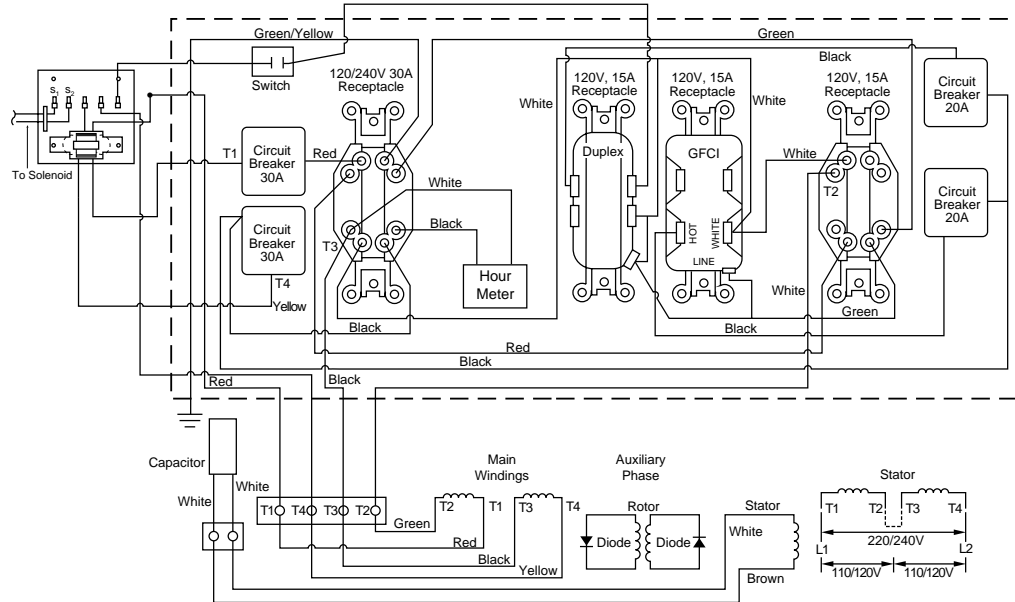

Figure 35 - Wiring Diagram, Model MGH7000DI

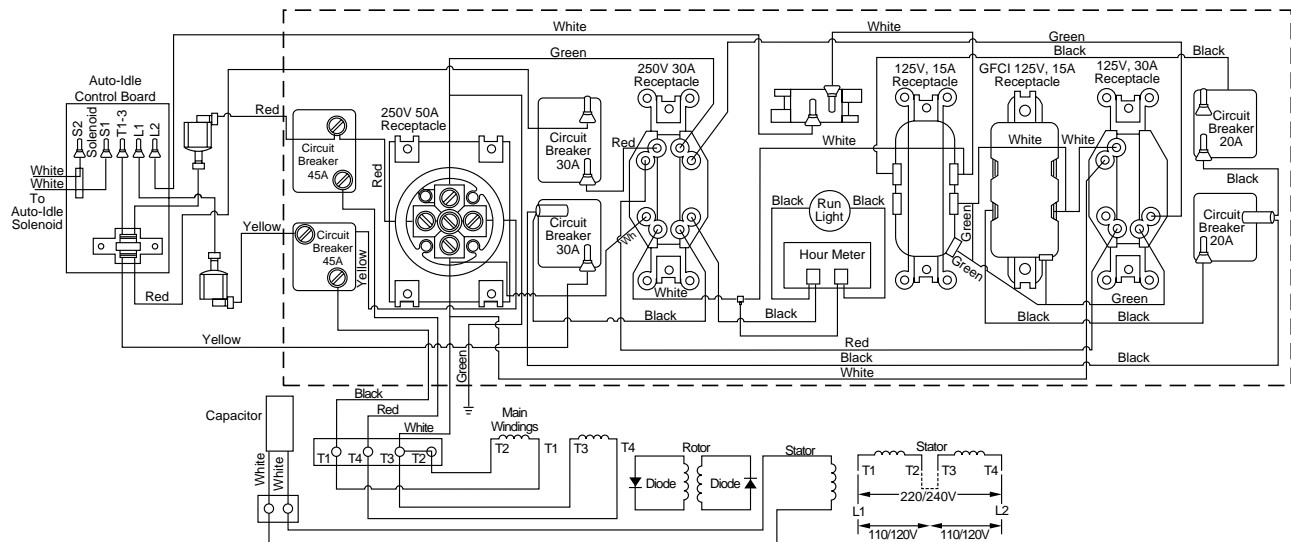

Figure 36 - Wiring Diagram, Model MGH10000A

# OWNER'S MANUAL

## TECHNICAL SERVICE

You may have further questions about installation, operation, or troubleshooting. If so, contact DESA International's Technical Service Department at 1-800-323-5190.

You can also visit DESA International's technical service web site at [www.desatech.com](http://www.desatech.com).

## SERVICING THE ENGINE

Honda parts and services should be handled by your nearest authorized engine service firm. Check the yellow pages of your telephone directory under the listing:

**Engines Gasoline, Honda**

## ACCESSORIES

**Heavy-Duty Wheel Kit – PA2020  
For Models MGH4000C,  
MGH4000CI, MGH5000D,  
MGH5000DI, MGH5000DIE,  
MGH6000D, MGH6000DI,  
MGH7000D, and MGH7000DI**

Wheelbarrow-style wheel kit. Makes generator easy for one person to move.

This kit includes:

- Large 12-inch wheels for easy rolling
- Powder coated tubing and plated hardware for long life
- Long handles with thick grips for greater comfort and control

Complete installation instructions included.

**Automatic Idle Kit – PA2010  
For Models MGH4000C,  
MGH5000D, MGH6000D, and  
MGH7000D**

Automatically reduces engine speed when no power is being used. Reduces fuel consumption and engine noise. Increases engine life.

Complete installation and operation instructions included.

## REPLACEMENT PARTS

*Note:* Use only original replacement parts. This will protect your warranty coverage for parts replaced under warranty.

### PARTS UNDER WARRANTY

Contact authorized dealers of this product. If they cannot supply original replacement part(s), either contact your nearest Parts Central or call DESA International's Technical Service Department at 1-800-323-5190.

When calling DESA International, have ready

- your name
- your address
- model number of your generator
- how generator is malfunctioning
- purchase date

Usually, we will ask you to return the defective part to the factory.

### PARTS NOT UNDER WARRANTY

Contact authorized dealers of this product. If they cannot supply original replacement part(s), either contact your nearest Parts Central or call DESA International's Parts Department at 1-800-972-7879 for referral information.

When calling DESA International, have ready

- model number of your generator
- the replacement part number

## PARTS CENTRALS

These Parts Centrals are privately owned businesses. They have agreed to support our customer's needs by providing original replacement parts and accessories.

### Baltimore Electric

1348 Dixwell Avenue  
Hamden, CT 06514  
1-800-397-7553  
203-248-7553

### Parts Company of America

1657 Shermer Road  
Northbrook, IL 60062  
1-800-323-0620  
708-498-5900

### Portable Heater Parts

342 N. County Road 400 East  
Valparaiso, IN 46383  
1-800-362-6951  
219-462-7441  
[sales@portableheaterparts.com](mailto:sales@portableheaterparts.com)  
[techservice@portableheaterparts.com](mailto:techservice@portableheaterparts.com)

### F B D

1349 Adams Street  
Bowling Green, KY 42103  
270-846-1199  
1-800-654-8534  
Fax: 1-800-846-0090  
[franktalk@aol.com](mailto:franktalk@aol.com)

### Master Parts Dist.

1251 Mound Ave. NW  
Grand Rapids, MI 49504-2672  
1-800-446-1446  
616-791-0505  
Fax: 616-791-8270  
[www.nbmc.com](http://www.nbmc.com)

### Laportes Parts & Service

2444 N 5th Street  
Hartsville, SC 29550  
803-332-0191

### MTA Distributors

555 Hickory Hills Blvd.  
Nashville, TN 37189-9244  
1-800-264-0225  
615-299-8777  
[www.mtadistributors.com](http://www.mtadistributors.com)

### Tuco Industrial Products

5223 18th Street SW  
Lynwood, WA 98037-4506  
425-743-9533  
1-800-735-1268  
Fax: 425-742-0218  
[www.tucoheat.com](http://www.tucoheat.com)

# MASTER

## PORTABLE GASOLINE GENERATORS

### ILLUSTRATED PARTS LIST

For Models HWI3000, MGH3000, and MGH3000PR Alternator Assembly

This list contains replaceable parts used in your generator. When ordering parts, follow the instructions listed under *Replacement Parts* on page 19 of this manual.

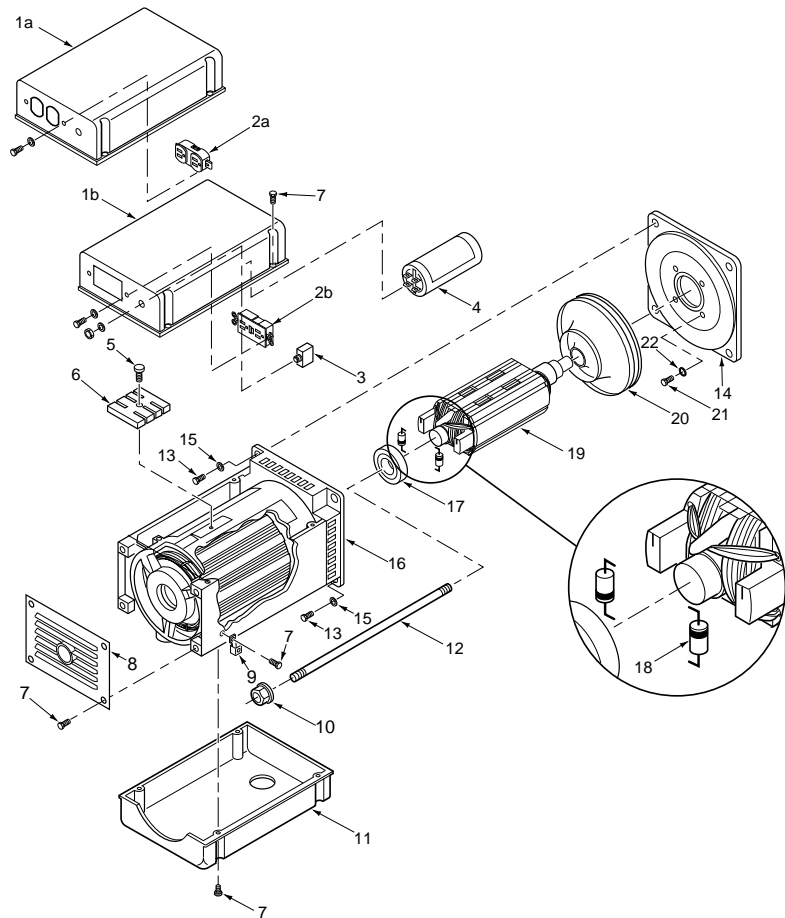

KEY NO.	PART NUMBER	DESCRIPTION	QTY.	KEY NO.	PART NUMBER	DESCRIPTION	QTY.
	099722-01	Alternator Assembly (HWI3000)*	1	9	17587000	Ground Lug	1
	099722-02	Alternator Assembly (MGH3000, and MGH3000PR)*	1	10	099891-01	Flanged Nut, 8mm	1
1a	099849-01	Top Cover (HWI3000)	1	11	099861-01	Bottom Cover	1
1b	100074-01	Top Cover (MGH3000, and MGH3000PR)	1	12	099842-01	Draw Bolt	1
2a	104201-01	120V, 20A Duplex Receptacle (HWI3000)†	1	13	26310000	Screw, M6 x 16	4
2b	100445-01	120V, 15A Duplex (GFCI) Receptacle (MGH3000 and MGH3000PR)†	1	14	27001005S	Engine Flange	1
3	22616009	Circuit Breaker, 20 Amp †	1	15	WLE-4	Lock Washer, 1/4"	4
4	27002002S	Capacitor	1	16	**	Stator	1
5	26333000	Screw, M4 x 30	1	17	27001002	Bearing	1
6	099863-01	Terminal Block	1	18	27001009S	Diode	2
7	099701-01	Screw, M5 x 13	13	19	**	Rotor	1
8	099848-01	End Plate	1	20	27001006	Fan	1
				21	26327006	Bolt, 5/16-24 x 5/8"	4
				22	WLE-5	Lock Washer, 5/16"	4
<b>PARTS AVAILABLE - NOT SHOWN</b>							
					099866-03	Safety Information Decal	1
					099866-04	Safety Information Decal	1
					099867-02	Operation Decal	1

† Includes fastening hardware.

\* Includes reference numbers 1 through 22.

\*\* Parts not available. Included in alternator assembly.

# OWNER'S MANUAL

## ILLUSTRATED PARTS LIST

For Models MGH4000C, MGH4000CI, MGH5000D, MGH5000DI, MGH5000DIE, MGH6000D, MGH6000DI, MGH7000D, and MGH7000DI Alternator Assembly

This list contains replaceable parts used in your generator. When ordering parts, follow the instructions listed under *Replacement Parts* on page 19 of this manual.

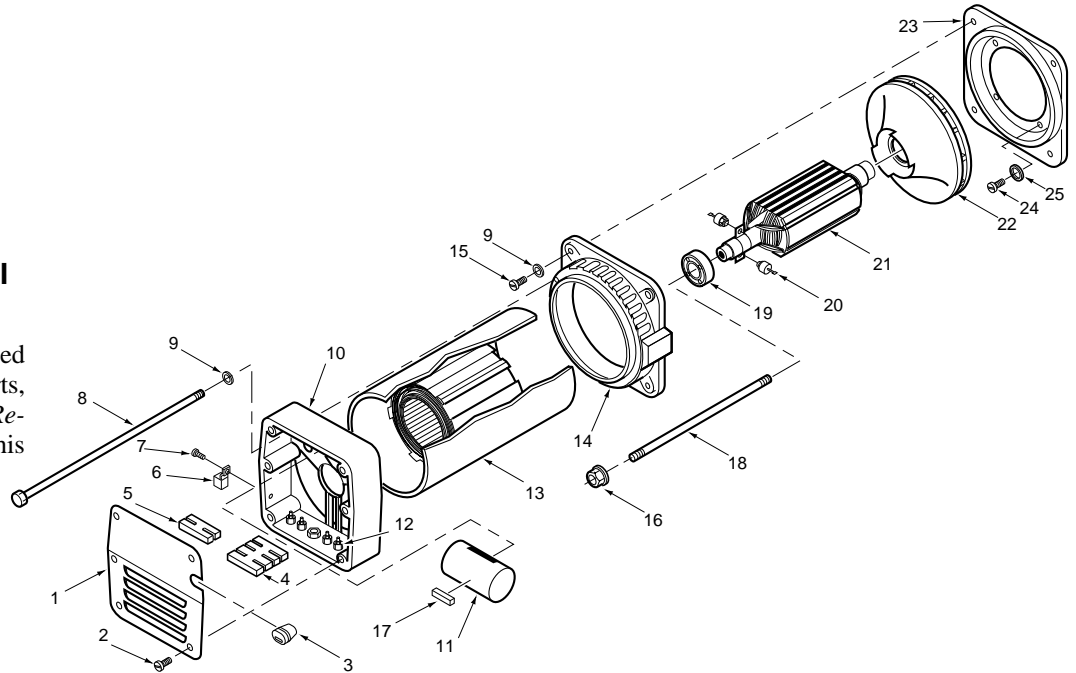

KEY NO.	PART NUMBER FOR MODEL				DESCRIPTION	QTY.
	MGH4000C MGH4000CI	MGH5000D MGH5000DI MGH5000DIE	MGH6000D MGH6000DI	MGH7000D MGH7000DI		
1	099723-01	099723-02	099723-03	099723-04	Alternator Assembly	1
2	099844-01	099844-01	099844-01	099844-01	End Cover	1
3	099701-01	099701-01	099701-01	099701-01	Screw, M5 x 13	6
4	099760-01	099760-01	099760-01	099760-01	Bushing	1
5	099863-01	099863-01	—	—	Terminal Block (4-block)	1
6	099863-02	099863-02	099863-02	099863-02	Terminal Block (2-block)	1
7	17587000**	17587000**	17587000**	17587000**	Ground Lug	1
8	M11084-26	M11084-26	M11084-26	M11084-26	Screw, #10-16 x 3/8"	1
9	099847-01	099847-02	099847-03	099847-04	Stator Bolt	4
10	WLE-5	WLE-5	WLE-5	WLE-5	Lock Washer, 5/16"	4
11	099843-01	099843-01	099843-01	099843-01	Bearing Housing	1
12	27004002S	27005003S	099845-01	27007004S	Capacitor	1
13	—	—	100054-01	100054-01	Terminal Post	4
14	*	*	*	*	Stator	1
15	27003002	27003002	27003002	27003002	Fan Bracket	1
16	27003015S**	27003015S**	27003015S**	27003015S**	Screw, M8 x 20	4
17	099891-01	099891-01	099891-01	099891-01	Rotor Nut, Flanged 8mm	1
18	099892-01	099892-01	099892-01	099892-01	Foam Pad	1
19	099842-01	099842-02	099842-03	099842-04	Draw Bolt	1
20	27003003	27003003	27003003	27003003	Bearing	1
21	27003012S	27003012S	27003012S	27003012S	Diode	2
22	*	*	*	*	Rotor	1
23	27003008	27003008	27003008	27003008	Fan	1
24	27003007S	27003007S	27003007S	27003007S	Engine Flange	1
25	26322004**	26322004**	26322004**	26322004**	Bolt, 3/8-16 x 5/8"	4
25	WLE-6**	WLE-6**	WLE-6**	WLE-6**	Lock Washer, 3/8"	4

\* Part not available by itself. Must purchase Alternator Assembly.

\*\*Available at your local hardware store.

# MASTER

## PORTABLE GASOLINE GENERATORS

### ILLUSTRATED PARTS LIST

#### For Model MGH1000A Alternator Assembly

This list contains replaceable parts used in your generator. When ordering parts, follow the instructions listed under *Replacement Parts* on page 19 of this manual.

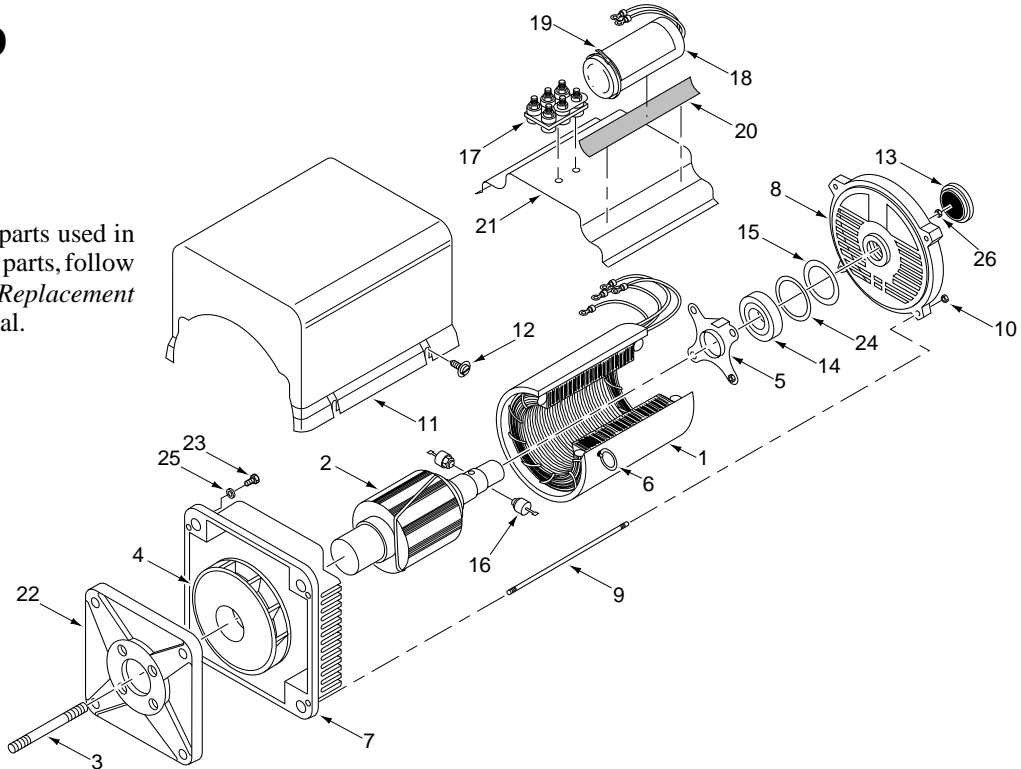

KEY NO.	DESCRIPTION	PART NUMBER	QTY.
1	Stator	*	1
2	Rotor	*	1
3	Draw Bolt	103188-01	1
4	Fan	103191-01	1
5	Balancing Disc	103192-01	1
6	Lifting Eyes	103193-01	2
7	D.E. Bracket	103194-01	1
8	N.D.E. Bracket	103195-01	1
9	Mounting Bolts	099847-05	4
10	Nuts	099891-01	4
11	Top Box	103189-01	1
12	Screw and Washer	099701-01	6
13	Plastic Cap	103198-01	1
14	Bearing	103199-01	1
15	Borelly Washer	103200-01	1
16	Diode	27003012S	2
17	Terminal Block	103201-01	1
18	Capacitor	099845-02	1
19	Tie Wrap	103204-01	1
20	Foam Pad	099892-02	1
21	Capacitor Bracket	103202-01	1
22	Engine Flange	103190-01	1
23	Screw M8 x 20	**	4
24	'O' Ring	103203-01	1
25	Washer	WLE-5	2
26	Hex Head Nut	099891-01	1
†	Alternator Assembly	102938-01	1

\* Part not available by itself. Must purchase Alternator Assembly.

\*\* Standard hardware item available from local hardware store.

# OWNER'S MANUAL

## ILLUSTRATED PARTS LIST

For Models HWI3000, MGH3000, and MGH3000PR Roll Cage

This list contains replaceable parts used in your generator. When ordering parts, follow the instructions listed under *Replacement Parts* on page 19 of this manual.

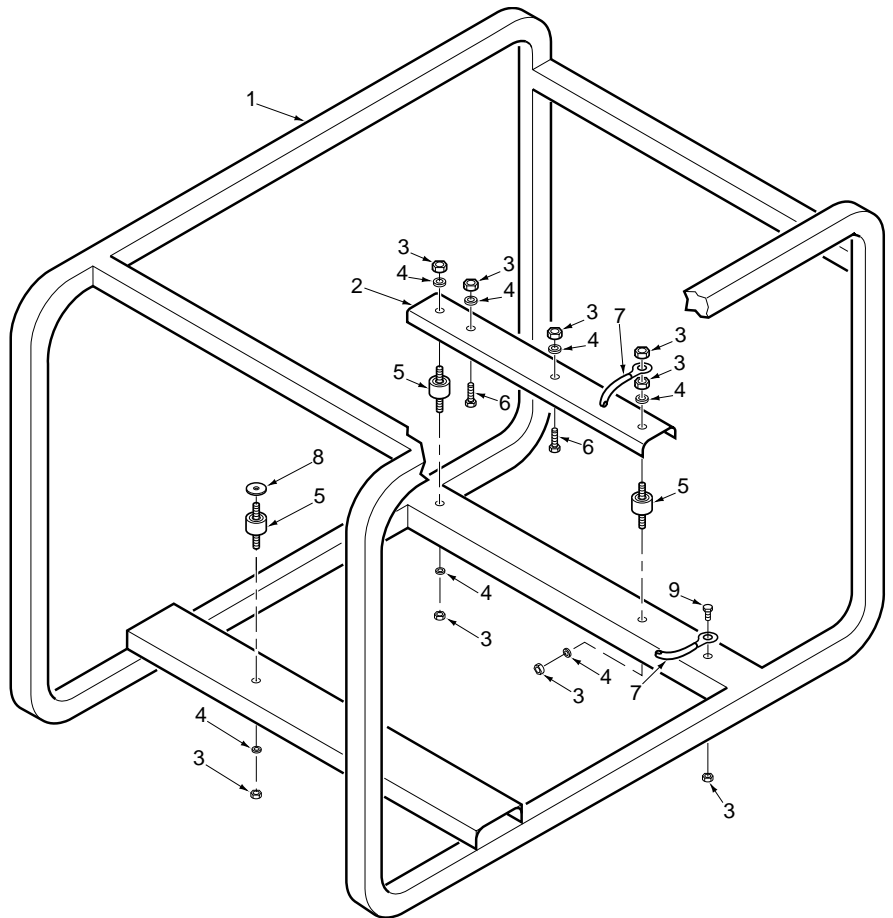

KEY NO.	PART NUMBER	DESCRIPTION	QTY.
1	105155-01	Roll Cage	1
2	099754-01	Engine Spreader	1
3	NEC-5C	Lock Nut, 5/16-18	9
4	WP-5C	Flat Washer, 5/16"	7
5	099853-02	Shock Mount	3
6	04110002	Screw, 5/16-18 x 1 1/2	2
7	14138000	Ground Strap	1
8	21834000	Washer, 5/16" x 1 1/2"	1
9	100406-01	Bolt, 5/16-18 x 3/4"	1

# MASTER

## PORTABLE GASOLINE GENERATORS

### ILLUSTRATED PARTS LIST

For Models MGH4000C,  
MGH4000CI, MGH5000D,  
MGH5000DI, MGH5000DIE,  
MGH6000D, MGH6000DI,  
MGH7000D, and MGH7000DI  
Fuel Tank and Roll Cage

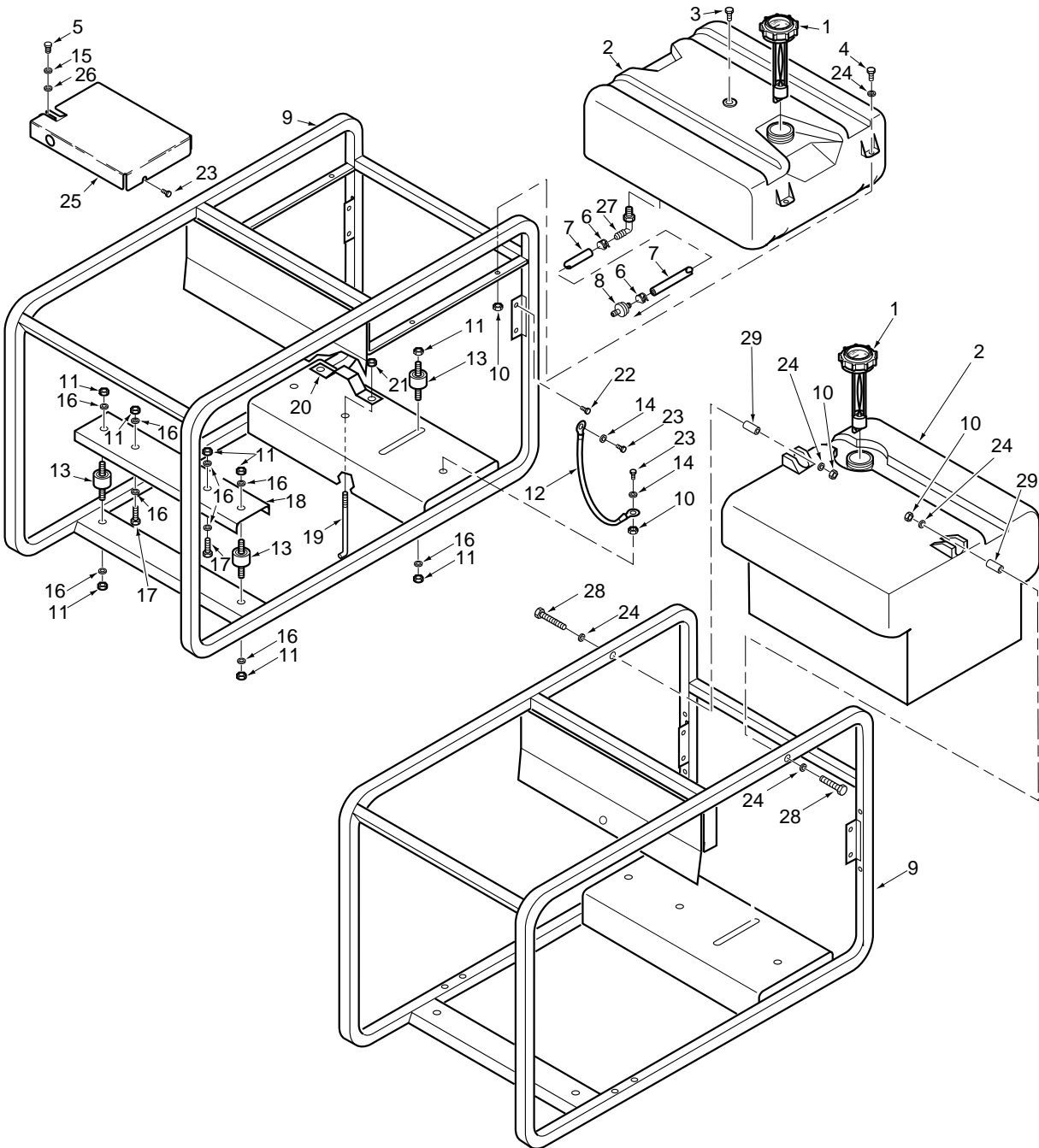



# OWNER'S MANUAL

## ILLUSTRATED PARTS LIST

This list contains replaceable parts used in your generator. When ordering parts, follow the instructions listed under *Replacement Parts* on page 19 of this manual.

For Models MGH4000C, MGH4000CI, MGH5000D, MGH5000DI,  
MGH5000DIE, MGH6000D, MGH6000DI, MGH7000D, and MGH7000DI  
Fuel Tank and Roll Cage

KEY NO.	MGH4000C MGH4000CI	MGH5000D MGH5000DI MGH5000DIE	MGH6000D MGH6000DI	MGH7000D MGH7000DI	DESCRIPTION	QTY.
1	25954000	25954001	25954001	25954001	Gas Cap/Fuel Gage	1
2	099832-01	107021-01	107021-01	107021-01	Gas Tank (with 90° fitting)	1
3	25978000	—	—	—	Breather Assembly	1
4	HC4-8C	—	—	—	Screw, 1/4-20 x 1"	4
5	099701-01	099701-01	099701-01	099701-01	Screw, M5 x 10	1
6	19508001	19508001	19508001	19508001	Gas Line Clamp	2
7	25985005	25985005	25985005	25985005	Fuel Line	1
8	099743-01	099743-01	099743-01	099743-01	Fuel Filter	1
9	099752-02	106063-01	106063-01	106063-01	Roll Cage	1
10	103880-01	—	—	—	Lock Nut, 1/4-20	5
	—	103880-01	103880-01	103880-01	Lock Nut, 1/4-20	3
11	NEC-5C	—	—	—	Lock Nut, 5/16-18	8
	—	NEC-5C	NEC-5C	NEC-5C	Lock Nut, 5/16-18	10
12	14138000	14138000	14138000	14138000	Ground Strap	1
13	099853-02	099853-02	099853-02	099853-02	Shock Mounts	3
14	WLE-5	WLE-5	WLE-5	WLE-5	Lock Washer, 5/16"	3
15	WLI-3	WLI-3	WLI-3	WLI-3	Lock Washer, #10	1
16	WP-5C	—	—	—	Flat Washer, 5/16"	9
	—	WP-5C	WP-5C	WP-5C	Flat Washer, 5/16"	11
17	HC5-14C	HC5-14C	HC5-14C	HC5-14C	Bolt, 5/16-18 x 1 3/4"	2
18	099756-01	099756-01	099756-01	099756-01	Engine Spreader	1
19	—	099750-01*	—	099750-01	Hook Bolt, 5/16-18	2
20	—	099749-01*	—	099749-01	Battery Mounting Bracket	1
21	—	NEC-5C*	—	NEC-5C	Lock Nut, 5/16-18	2
22	100410-01	100410-01	100410-01	100410-01	Sems Screw, #8-18 x 1/2"	4
23	M10908-74	M10908-74	M10908-74	—	Screw, 1/4-20 x 1/2"	3
	—	M10908-74*	—	M10908-74	Screw, 1/4-20 x 1/2"	2
24	WP-4C	WP-4C	WP-4C	WP-4C	Washer, 1/4"	4
25	099965-01	099965-01	099965-01	099965-01	Linkage Cover	1
26	WP-3C	WP-3C	WP-3C	WP-3C	Washer, #10	1
27	103676-01	103676-01	103676-01	103676-01	90° Fitting with barbs	1
28	—	HC4-16C	HC4-16C	HC4-16C	Bolt, 1/4-20 X 2"	2
29	—	107110-01	107110-01	107110-01	Spacer .25 X .500	2
<b>PARTS AVAILABLE - NOT SHOWN</b>						
	099866-02	—	—	—	Safety Information Decal	1
	100003-01	100003-01	100003-01	—	Operation Decal	1
	—	100003-02*	—	100003-02	Operation Decal	1
	—	099873-01*	—	099873-01	Battery Cable (Positive, Red)	1
	—	099873-02*	—	099873-02	Battery Cable (Negative, Black)	1
	03175000	03175000	03175000	03175000	Fuel Line Grommet	3

\* Only on MGH5000DIE electric start models

# MASTER

## PORTABLE GASOLINE GENERATORS

### ILLUSTRATED PARTS LIST

For Model MGH10000A Fuel  
Tank and Roll Cage

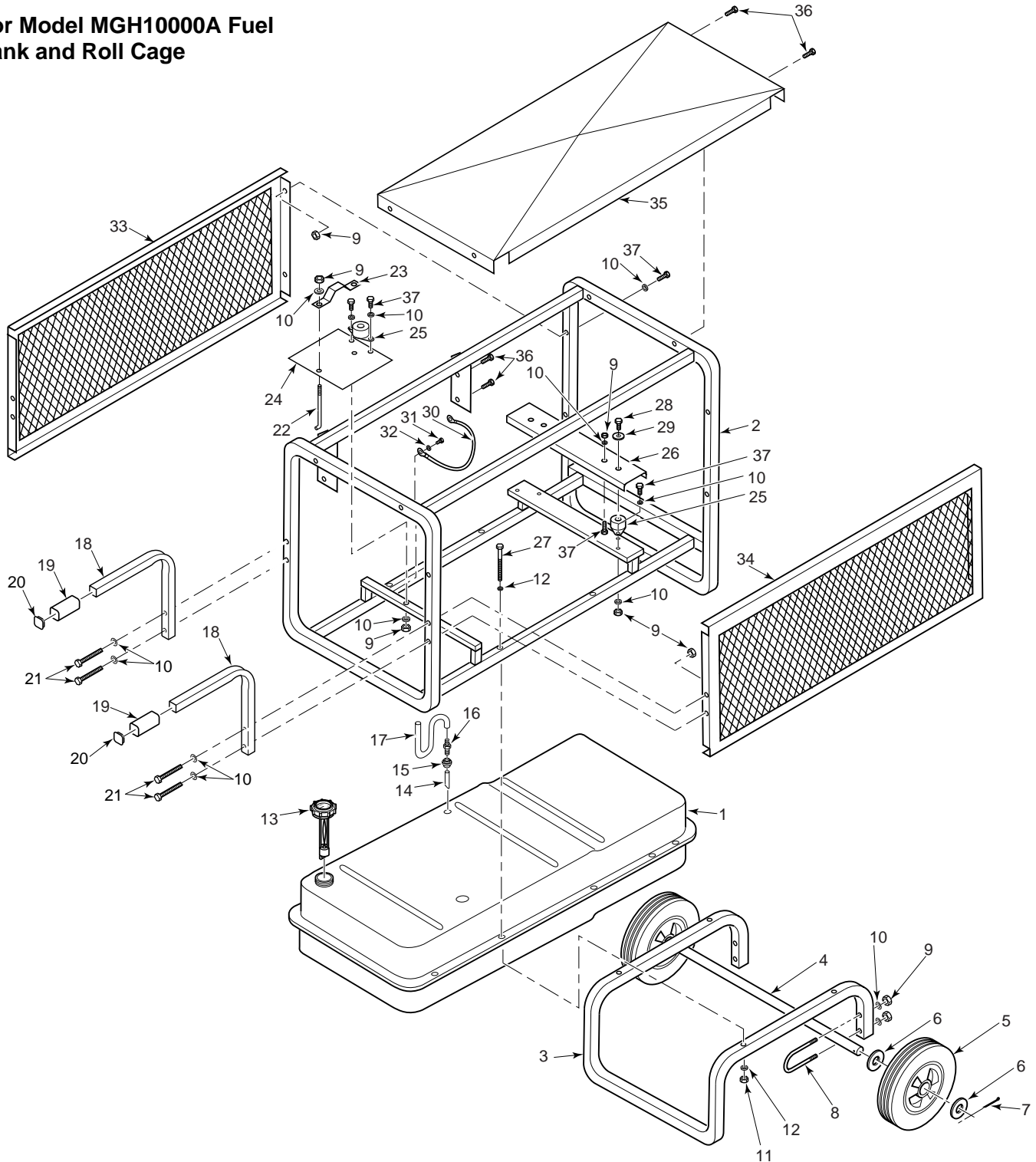

# OWNER'S MANUAL

## ILLUSTRATED PARTS LIST

### For Model MGH10000A Fuel Tank and Roll Cage

This list contains replaceable parts used in your generator. When ordering parts, follow the instructions listed under *Replacement Parts* on page 19 of this manual.

KEY NO.	PART NUMBER	DESCRIPTION	QTY.
1	079503-25AA	Gas Tank Assembly	1
2	105905-01	Roll Cage	1
3	105906-01	Axle Mount	1
4	102933-03	Axle	1
5	102932-01	Wheels	2
6	WP-16C	Flat Washer, 1"	4
7	C4-12C	Cotter Pin	2
8	100135-01	U-Bolt	2
9	NEC-5C	Lock Nut, 5/16-18	22
10	WP-5C	Flat Washer, 5/16"	30
11	103880-01	Lock Nut, 1/4-20	4
12	WP-4C	Flat Washer, 1/4"	8
13	097190-06	Gas Cap w/Fuel Gage	1
14	M51151-02	Fuel Line	1
15	M10990-3	Bushing	1
16	106988-01	Barbed Connector, 1/4"	1
17	25985008	Fuel Line	1
18	105035-01	Handle	2
19	103046-01	Grip	2
20	103057-01	Plug	2
21	H8C5-20C	Bolt, 5/16-18 x 2.5"	4
22	099750-01	Bolt, J-Hook 5/16-18	2
23	099749-01	Battery Bracket	1
24	105908-01	Battery Mount	1
25	17529000	Shock Mount	3
26	102962-02	Spreader	1
27	H5C4-24C	Bolt, 1/4-20 x 3"	4
28	26302006	Bolt, 1/2-10 x 1"	2
29	WLI-8	Internal Tooth Lockwasher	2
30	14138000	Ground Strap	1
31	M10908-74	Tapping Screw, 1/4-20 x .5"	1
32	WLE-5	External Tooth Lockwasher	1
33	106775-02	Side Panel	1
34	106775-01	Side Panel	1
35	106776-01	Top Cover	1
36	100410-01	Sems Screw, 8-18	8
37	HC5-14C	Bolt, 5/16-18 x 1.75"	6
<b>PARTS AVAILABLE NOT SHOWN</b>			
	099866-05	Safety Information Decal	1
	100003-04	Operation Decal	1
	099873-01	Battery Cable (Positive, Red)	1
	099873-05	Battery Cable (Negative, Black)	1
	HC4-6C	Screw, 1/4-20 x .75"	2

# MASTER

## PORTABLE GASOLINE GENERATORS

### ILLUSTRATED PARTS LIST

For Models MGH4000C, MGH4000CI, MGH5000D, MGH5000DI, MGH5000DIE, MGH6000D, MGH6000DI, MGH7000D, and MGH7000DI Control Panel

This list contains replaceable parts used in your generator. When ordering parts, follow the instructions listed under *Replacement Parts* on page 19 of this manual.

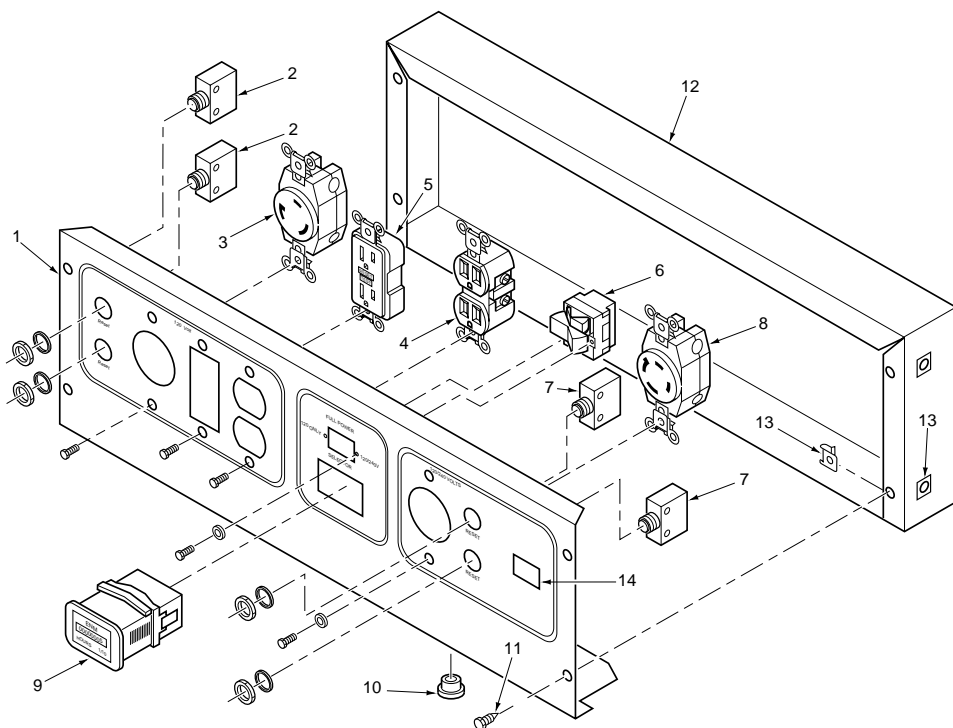

KEY NO.	PART NUMBER FOR MODEL				DESCRIPTION	QTY.
	MGH4000C MGH4000CI	MGH5000D MGH5000DIE	MGH6000D MGH6000DI	MGH7000D MGH7000DI		
1	103349-01	103349-02	103349-03	103349-04	Control Panel	1
2	22616009	22616009	22616009	22616009	Circuit Breaker, 20 Amp *	2
3	099833-01	099833-01	099833-01	099833-01	120V, 30A Twist-Lock Receptacle *	1
4	15324000	15324000	15324000	15324000	120V, 15A Duplex Receptacle *	1
5	100445-01	100445-01	100445-01	100445-01	120V, 15A Duplex (GFCI) Receptacle *	1
6	099956-01	099956-01	099956-01	—	Full Power Selector Switch *	1
7	22616009	—	—	—	Circuit Breaker, 20 Amp *	2
	—	22616011	—	—	Circuit Breaker, 25 Amp *	2
	—	—	22616010	22616010	Circuit Breaker, 30 Amp *	2
8	099834-01	099834-01	099834-01	—	120/240V, 20A Twist-Lock Receptacle *	1
	—	—	—	099835-01	120/240V, 30A Twist-Lock Receptacle *	1
9	101350-01	101350-01	101350-01	101350-01	Hour Meter	1
10	099760-01	099760-01	099760-01	099760-01	Bushing	1
11	100410-01	100410-01	100410-01	100410-01	Sems Screw, #8-18 x 1/2"	4
12	100149-01	100149-01	100149-01	100149-01	Control Box	1
13	22261000	22261000	22261000	22261000	U-Nut	8
14	099997-01	099997-01	099997-01	099997-01	Switch Plug	1
†	103348-01	103348-02	103348-03	103348-04	Control Panel Assembly	1
†	103348-05	103348-06	103348-07	103348-08	Control Panel Assembly - Auto Idle Models	1
Δ	100177-07	100177-07	100177-07	100177-07	Panel Schematic Decal	1

\* Includes fastening hardware

Δ Not shown

† Includes reference numbers 1 through 13

# OWNER'S MANUAL

## ILLUSTRATED PARTS LIST

### For Model MGH1000A Control Panel

This list contains replaceable parts used in your generator. When ordering parts, follow the instructions listed under *Replacement Parts* on page 19 of this manual.

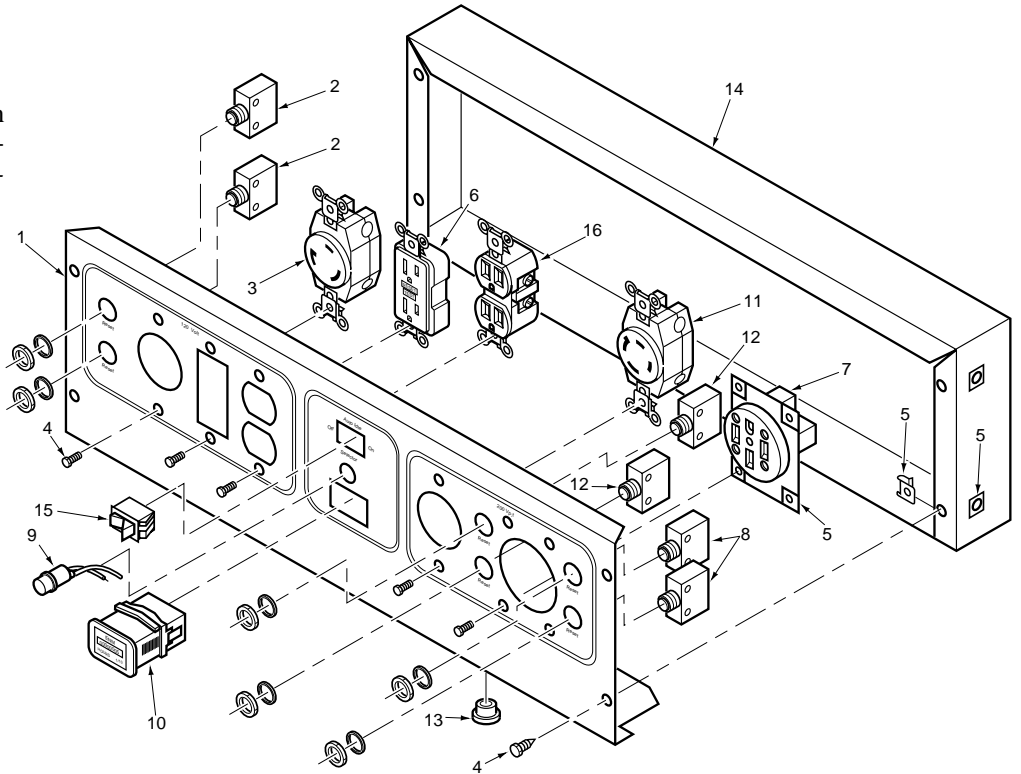

KEY NO.	PART NUMBER	DESCRIPTION	QTY.
1	103182-01	Control Panel	1
2	22616009	Circuit Breaker, 20 Amp	2
3	099833-01	120V, 30A Twist-Lock Receptacle	1
4	100410-01	Sems Screw, #8-18 x 1/2"	16
5	22261000	U-Nut	20
6	100445-01	20V, 15A Duplex (GFCI) Receptacle	1
7	103183-01	125/250V, 50A Receptacle	1
8	103184-01	Circuit Breaker, 45 Amp	2
9	26299000	Run Light	1
10	101350-01	Hour Meter	1
11	099834-01	120/240V, 20A Twist-Lock Receptacle	1
12	22616010	Circuit Breaker, 30 Amp	2
13	099760-01	Bushing	1
14	103185-01	Control Box	1
15	100366-01	Rocker Switch	1
16	15324000	120V, 15A Duplex Receptacle	1
†	102927-01	Control Panel Assembly	1
Δ	100177-05	Panel Schematic Diagram	1
Δ	103257-01	Auto Idle PC Board Kit	1
Δ	103258-02	Solenoid Assembly Kit (With Bracket)	1

† Includes reference numbers 1 through 16

Δ Not shown

# MASTER®

## PORTABLE GASOLINE GENERATORS

### ILLUSTRATED PARTS LIST

For Solenoid and Control Board  
Assemblies and Mounting

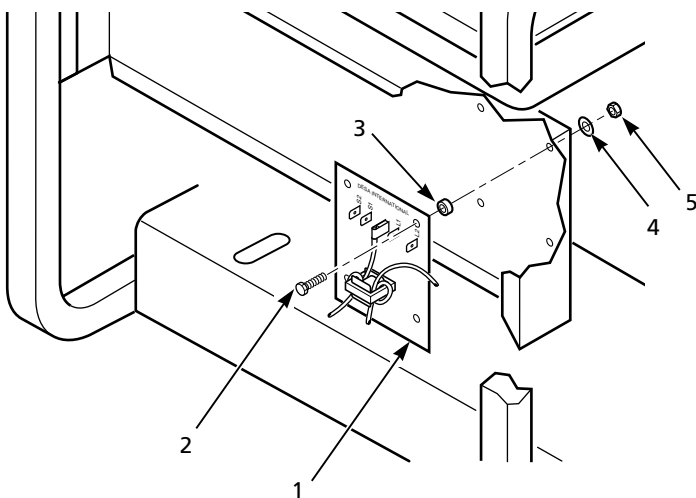
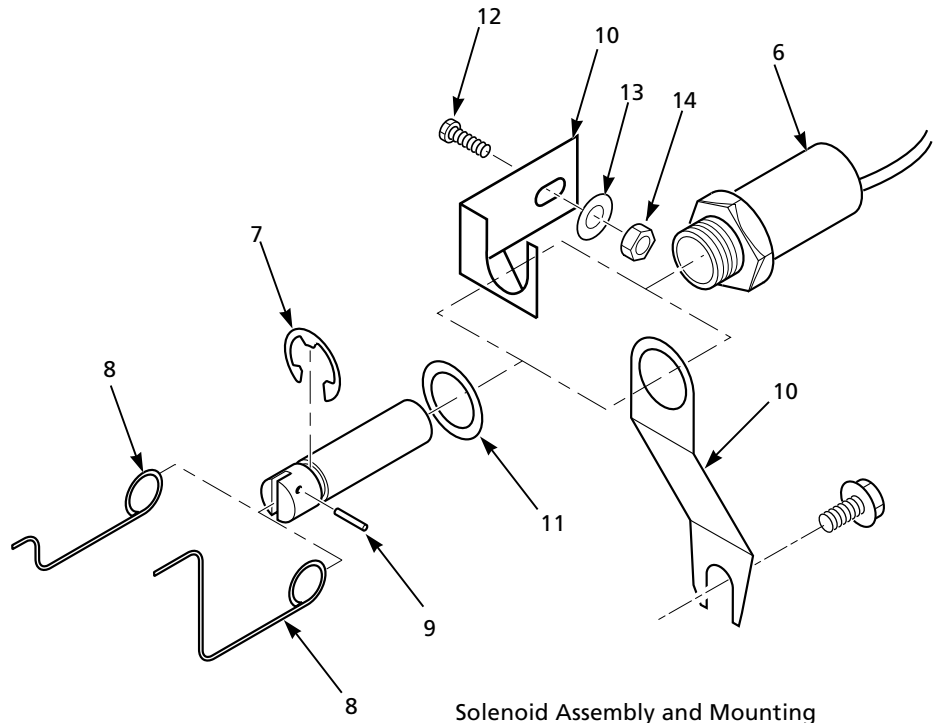

# OWNER'S MANUAL

## ILLUSTRATED PARTS LIST

### For Solenoid and Control Board Assemblies and Mounting

This list contains replaceable parts used in your generator. When ordering parts, follow the instructions listed under *Replacement Parts* on page 19 of this manual.

KEY NO.	PART NUMBER	DESCRIPTION	QTY.
1	100105-01	Control Board Assembly	1
2	26499000	Hex Head Screw, 10-32 x 3/4"	4
3	100321-01	Nylon Spacer	4
4	WP-C3	Flat Washer, #10	4
5	26514000	Lock Nut, 10-32	4
6	100324-03	Solenoid Assembly (Includes Plunger, Nut, and Lock Washer)	1
7	103812-01	Retaining Ring*	1
8	100755-02	Linkage Rod*	1
	100755-01	Linkage Rod	1
9	22822000	Roll Pin	1
10	102939-01	Solenoid Mounting Bracket*	1
	100756-01	Solenoid Mounting Bracket	1
11	103811-01	Nylon Washer*	1
12	100328-01	Bolt, M8 x 25mm †	1
13	02407002	Flat Washer, 5/16" †	1
14	100329-01	Lock Nut, M8 †	1
<b>PARTS AVAILABLE NOT SHOWN</b>			
	100320-01	Yellow Wire	1
	100322-01	White Wire (with 2 Flags)	1
	100322-02	White Wire (with 1 Flag and 1 Spade)	1
	100366-01	Rocker Switch	1
	100334-01	Auto-Idle Decal	1

\* Model MGH10000A Only

† All Models Except MGH10000A

# WARRANTY INFORMATION

## KEEP THIS WARRANTY

Model \_\_\_\_\_

Serial No. \_\_\_\_\_

Date Purchased \_\_\_\_\_

Always specify model and serial numbers when communicating with the factory.

We reserve the right to amend these specifications at any time without notice. The only warranty applicable is our standard written warranty. We make no other warranty, expressed or implied.

*Note:* The two-year limited warranty below covers all non-engine parts of this generator including the alternator. Honda warrants the engine. See engine owner's manual for engine warranty information.

### TWO-YEAR LIMITED WARRANTY GASOLINE PORTABLE GENERATORS

DESA International warrants each alternator, generator, or electric product of its manufacture, to be free from defects in material and workmanship for two years from the date of first purchase from an authorized dealer, provided that the product has been properly installed, maintained, and operated in accordance with all applicable instructions. The bill of sale or proof of purchase must be presented at the time a claim is made under this warranty.

This warranty is extended only to the original retail purchaser. This warranty covers only the parts and labor required to restore this unit to its proper operating condition. Warranty parts must be obtained through factory authorized dealers and service centers for this product. These dealers and service centers will provide original factory replacement parts. Failure to use original factory replacement parts voids this warranty.

This warranty does not apply to parts that are not in original condition because of normal wear and tear, or parts that fail or become damaged as a result of misuse, abuse, negligence, accident, lack of proper maintenance, alteration, modification, tampering, contaminated fuels, repair using improper parts, or repair by anyone other than an authorized dealer or service center. Routine maintenance is the responsibility of the owner. Travel, handling, transportation, and incidental costs associated with warranty repairs are not reimbursable under this warranty and are the responsibility of the owner.

DESA International makes no warranty with respect to the engine and engine components not of its manufacture. They are subject to warranties of their manufacturers.

To the full extent allowed by the law of the jurisdiction that governs the sale of the product, this express warranty excludes any and all other expressed warranties and limits the duration of any and all implied warranties, including warranties of merchantability and fitness for a particular purpose to two years from the date of first purchase, and DESA International's liability is hereby limited to the purchase price of the product and DESA International shall not be liable for any other damages whatsoever including indirect, incidental, or consequential damages.

Some states do not allow limitation of how long an implied warranty lasts or an exclusion or limitation of incidental or consequential damages, so the above limitation of damages may not apply to you.

This warranty provides the original purchaser with specific rights. For information regarding those rights, please consult the applicable state laws.



NOT A UPC

**DESA**  
INTERNATIONAL

2701 Industrial Drive  
P.O. Box 90004  
Bowling Green, KY 42102-9004  
www.desatech.com

106813-01  
REV. B  
03/00



## Free Manuals Download Website

<http://myh66.com>

<http://usermanuals.us>

<http://www.somanuals.com>

<http://www.4manuals.cc>

<http://www.manual-lib.com>

<http://www.404manual.com>

<http://www.luxmanual.com>

<http://aubethermostatmanual.com>

Golf course search by state

<http://golfingnear.com>

Email search by domain

<http://emailbydomain.com>

Auto manuals search

<http://auto.somanuals.com>

TV manuals search

<http://tv.somanuals.com>