

Service Manual

Simplified

Personal Computer

CF-74ECBAXBM

TOUGHBOOK

 **WARNING**

This service information is designed for experienced repair technicians only and is not designed for use by the general public. It does not contain warnings or cautions to advise non-technical individuals of potential dangers in attempting to service a product. Products powered by electricity should be serviced or repaired only by experienced professional technicians. Any attempt to service or repair the product or products dealt with in this service information by anyone else could result in serious injury or death.

Panasonic[®]

© 2006 Matsushita Electric Industrial Co., Ltd. All rights reserved.
Unauthorized copying and distribution is a violation of law.

WARNINGS

For U.K.

This apparatus must be earthed for your safety.

To ensure safe operation the three-pin plug must be inserted only into a standard three-pin power point which is effectively earthed through the normal household wiring.

Extension cords used with the equipment must be three-core and be correctly wired to provide connection to earth. Wrongly wired extension cords are a major cause of fatalities.

The fact that the equipment operates satisfactorily does not imply that the power point is earthed and that the installation is completely safe.

For your safety, if you have any doubt about the effective earthing of the power point, consult a qualified electrician.

FOR YOUR SAFETY PLEASE READ THE FOLLOWING TEXT CAREFULLY

This appliance is supplied with a moulded three pin mains plug for your safety and convenience.

A 3 amp fuse is fitted in this plug.

Should the fuse need to be replaced please ensure that the replacement fuse has a rating of 3 amps and that it is approved by ASTA or BSI to BS 1362.

Check for the ASTA mark  or the BSI mark  on the body of the fuse.

If the plug contains a removable fuse cover you must ensure that it is refitted when the fuse is replaced.

If you lose the fuse cover the plug must not be used until a replacement cover is obtained.

A replacement fuse cover can be purchased from your local Panasonic Dealer.

IF THE FITTED MOULDED PLUG IS UNSUITABLE FOR THE SOCKET OUTLET IN YOUR HOME THEN THE FUSE SHOULD BE REMOVED AND THE PLUG CUT OFF AND DISPOSED OF SAFELY.

THERE IS A DANGER OF SEVERE ELECTRICAL SHOCK IF THE CUT OFF PLUG IS INSERTED INTO ANY 13 AMP SOCKET.

If a new plug is to be fitted please observe the wiring code as shown below.

If in any doubt please consult a qualified electrician.

Warning: THIS APPLIANCE MUST BE EARTHED.

Important

The wires in this mains lead are coloured in accordance with the following code:

| | |
|-------------------|---------|
| Green-and-yellow: | Earth |
| Blue: | Neutral |
| Brown: | Live |

As the colours of the wires in the mains lead of this apparatus may not correspond with the coloured markings identifying the terminals in your plug, proceed as follows:

The wire which is coloured GREEN-and-YELLOW must be connected to the terminal in the plug which is marked by the letter E or by the safety earth symbol  coloured GREEN or GREEN-and-YELLOW.

The wire which is coloured Blue must be connected to the terminal which is marked with the letter N or coloured BLACK.

The wire which is coloured Brown must be connected to the terminal which is marked with the letter L or coloured RED.

The mains plug on this equipment must be used to disconnect the mains power.

Please ensure that a socket outlet is available near the equipment and shall be easily accessible.

How to replace the fuse

Open the fuse compartment with a screw-driver and replace the fuse.

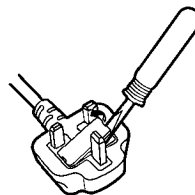

Warnings

- This equipment is not designed for connection to an IT power system.
(An IT system is a system having no direct connections between live parts and Earth; the exposed-conductive-parts of the electrical installation are earthed.
An IT system is not permitted where the computer is directly connected to public supply systems in the U.K.)
- Disconnect the mains plug from the supply socket when the computer is not in use.

This equipment is produced to BS800/1983.

LASER SAFETY INFORMATION

For U.S.A.

Class 1 LASER-Product

This product is certified to comply with DHHS Rules 21 CFR Subchapter J.

This product complies with European Standard EN60825 (or IEC Publication 825)

For all areas

This equipment is classified as a class 1 level LASER product and there is no hazardous LASER radiation.

Caution:

- (1) Use of controls or adjustments or performance of procedures other than those specified herein may result in hazardous radiation exposure.
- (2) The drive is designed to be incorporated into a computer-based system or unit which has an enclosing cover. It should never be used as a stand alone drive.

Danger:

The serviceman should not remove the cover of drive unit and should not service because the drive unit is a non-serviceable part.

Please check DANGER label on PD-drive unit.

- Unplug the AC power cord to the equipment before opening the top cover of the drive.
- When the power switch it on, do not place your eyes close to the front panel door to look into the interior of the unit.

LASER Specification

Class 1 level LASER Product

Wave Length: DVD 658±8 nm

CD 775~815 nm

Laser safety information is appropriate only when drive with laser is installed.

Safety precautions

1. Before servicing, unplug the power cord to prevent an electric shock.
2. When replacing parts, use only manufacture's recommended components for safety.
3. Check the condition of the power cord. Replace if wear or damage is evident.
4. After servicing, be sure to restore the lead dress, insulation barriers, insulation papers, shields, etc.

Important Safety Instructions

When using your telephone equipment, basic safety precautions should always be followed to reduce the risk of fire, electric shock and injury to persons, including the following:

1. Do not use this product near water, for example, near a bath tub, wash bowl, kitchen sink or laundry tub, in a wet basement or near a swimming pool.
2. Avoid using a telephone (other than a cordless type) during an electrical storm. There may be a remote risk of electric shock from lightning.
3. Do not use the telephone to report a gas leak in the vicinity of the leak.
4. Use only the power cord and batteries indicated in this manual. Do not dispose of batteries in a fire. They may explode. Check with local codes for possible special disposal instructions.

SAVE THESE INSTRUCTIONS

LITHIUM BATTERY ⚠

• CAUTION

Danger of explosion if battery is incorrectly replaced.

Replace only with the same or equivalent type recommended by the equipment manufacture.

Discard used batteries according to the manufacturer's instructions.

LITHIUMBATTERIES ⚠

Vorsicht!

Explosionsgefahr bei unsachgemäßem Austausch der Batterie. Ersatz nur durch denselben oder einen vom Hersteller empfohlenen ähnlichen Typ. Entsorgung gebrauchter Batterien nach Angaben des Herstellers.

PILE AU LITHIUM ⚠

ATTENTION: IL Y A DANGER D'EXPLOSION S' IL Y A REMPLACEMENT INCORRECT DE LA PILE. REMPLACER UNIQUEMENT AVEC UNE PILE DU MÊME TYPE OU D'UN TYPE RECOMMANDÉ PAR LE CONSTRUCTEUR. METTRE AU RÉBUT LES PILES USAGÉES CONFORMÉMENT AUX INSTRUCTIONS DU FABRICANT.

For U.S.A. / CANADA



A lithium ion battery that is recyclable powers the product you have purchased. Please call 1-800-8-BATTERY for information on how to recycle this battery.

L'appareil que vous vous êtes procuré est alimenté par une batterie au lithium-ion. Pour des renseignements sur le recyclage de la batterie, veuillez composer le 1-800-8-BATTERY.

Lithium Battery

Lithium Battery!

This computer contains a lithium battery to enable the date, time, and other data to be stored. The battery should only be exchanged by authorized service personnel.

Warning! A risk of explosion from incorrect installation or mis-application may possibly occur.

Precautions (Battery Pack)

- Care should be exercised with regard to the following in order to avoid the possibility of overheating, fire or damage.



Avoid Heat

Do not throw the battery pack into a fire or expose it to excessive heat.



Keep Articles Away

Do not place the battery pack together with articles such as necklaces or hairpins when carrying or storing.



Do Not Disassemble

Do not insert sharp objects into the battery pack, expose it to bumps or shocks, deform, disassemble, or modify it.



Do Not Short

Do not short the positive (+) and negative (-) contacts.



Avoid Extreme Heat, Cold and Direct Sunlight

Do not charge, use or leave the battery pack for extended periods where it will be exposed to direct sunlight, in a hot place (in an automobile on a sunny day, for example), or in a cold place.



Do Not Use With Any Other Computer

The battery pack is rechargeable and was intended for the specified computer or charger. Do not use it with a computer other than the one for which it was designed.



Do Not Put into a Microwave

Do not put the battery pack into a microwave oven or a pressurized chamber.



Discontinue Use

Should the battery emit an abnormal odor, become hot to the touch, become discolored, change shape, or become in any way different from normal, remove it from the computer or charger and discontinue use.

- Do not touch the terminals on the battery pack. The battery pack may no longer function properly if the contacts are dirty or damaged.
- Do not expose the battery pack to water, or allow it to become wet.

- If the battery pack will not be used for a long period of time (a month or more), charge or discharge (use) the battery pack until the remaining battery level becomes 30% to 40% and store it in a cool, dry place.
- This computer prevents overcharging of the battery by recharging only when the remaining power is less than approx. 95% of capacity.
- The battery pack is not charged when the computer is first purchased. Be sure to charge it before using it for the first time. When the AC adaptor is connected to the computer, charging begins automatically.
- Should the battery leak and the fluid get into your eyes, do not rub your eyes. Immediately flush your eyes with clear water and see a doctor for medical treatment as soon as possible.

NOTE

- The battery pack may become warm during recharging or normal use. This is completely normal.
- Recharging will not commence outside of the allowable temperature range (0 °C to 50 °C {32°F to 122 °F}). (☞ Reference Manual “Battery Power”) Once the allowable range requirement is satisfied, charging begins automatically. Note that the recharging time varies based on the usage conditions. (Recharging takes longer than usual when the temperature is 10 °C {50 °F} or less.)
- If the temperature is low, the operating time is shortened. Only use the computer within the allowable temperature range.
- The battery pack is a consumable item. If the amount of time the computer can be run off a particular battery pack becomes dramatically shorter and repeated rechargings do not restore its performance, the battery pack should be replaced with a new one.
- When transporting spare batteries inside a package, briefcase, etc., it is recommended that it be placed in a plastic bag so that its contacts are protected.
- Always power off the computer when it is not in use. Leaving the computer on when the AC adaptor is not connected will exhaust the remaining battery capacity.

CONTENTS

| | |
|---|------|
| 1. Specifications | 1-1 |
| 2. Names and Functions of Parts | 2-1 |
| 3. Block Diagram | 3-1 |
| 4. Diagnosis Procedure | 4-1 |
| 5. Power-On Self Test (Boot Check) | 5-1 |
| 6. List of Error Codes <Only when the port replicator is connected> | 6-1 |
| 7. Self Diagnosis Test | 7-1 |
| 8. Wiring Connection Diagram | 8-1 |
| 9. Disassembly/Reassembly | 9-1 |
| 10. Exploded View | 10-1 |
| 11. Replacement Parts List | 11-1 |

1 Specifications

This page provides the specifications for the basic model CF-74ECBAXBM / CF-74FCBAZBM / CF-74FCBCZBM / CF-74ECBCXBM / CF-74ECBADBM. The model number is different according to the unit configuration.

- To check the model number:
Check the bottom of the computer or the box the computer came in at the time of purchase.
- To check CPU speed, memory size and the hard disk drive (HDD) size:
Run the Setup Utility (→  *Reference Manual* "Setup Utility") and select [Information] menu.
[CPU Speed]: CPU speed, [System Memory]: Memory size, [Hard Disk]: Hard disk drive size

■ Main Specifications

| | | |
|--------------------------------------|--|--|
| Model No. | CF-74ECBAXBM / CF-74FCBAZBM / CF-74FCBCZBM / CF-74ECBCXBM / CF-74ECBADBM | |
| CPU | Intel® Core™ Duo Processor T2500 (2.0 GHz, 2 MB ^{*1} L2 cache, 667 MHz FSB) | |
| Chipset | Intel® 945GM | |
| Memory ^{*1} | 512 MB (2560 MB Max.) | |
| Video Memory ^{*1*2} | UMA (128 MB Max.) | |
| Hard Disk Drive ^{*3} | 80 GB | |
| CD/DVD Drive | DVD-ROM & CD-R/RW Drive | |
| Data Transfer Rate ^{*4} | Reading ^{*5} | DVD-ROM: 8X (Max.), CD-ROM: 24X (Max.) |
| | Writing ^{*6} | CD-R: 4X/10X/7-16X/10-24X CD-RW: 4X High-Speed CD-RW: 4X/10X Ultra-Speed CD-RW: 10X/10-24X |
| Supported Discs/Format ^{*3} | Reading | DVD-ROM (4.7 GB, 8.5 GB, 9.4 GB, 17 GB), DVD-Video, DVD-R (1.4 GB, 3.95 GB, 4.7 GB), DVD-R DL (8.5 GB), DVD-RW ^{*7} (1.4 GB, 2.8 GB, 4.7 GB, 9.4 GB), DVD-RAM ^{*8} (1.4 GB, 2.8 GB, 2.6 GB, 5.2 GB, 4.7 GB, 9.4 GB), +R (4.7 GB), +R DL (8.5 GB), +RW (4.7 GB), CD-Audio, CD-ROM, CD-R, Photo CD, Video CD, CD-RW, CD TEXT, CD-EXTRA |
| | Writing | CD-R, CD-RW, High-Speed CD-RW, Ultra-Speed CD-RW |
| Display Method | 13.3 type (TFT) with Touchscreen | |
| Internal LCD ^{*9} | 65,536/16,777,216 colors (800 × 600 dots/1024 × 768 dots) | |
| External Display ^{*10} | 65,536/16,777,216 colors (800 × 600 dots/1024 × 768 dots/1280 × 1024 dots/1600 × 1200 dots/2048 × 1536 dots) | |
| Wireless LAN ^{*11} | → Next Page Wireless LAN | |
| Bluetooth ^{*12} | Version 2.0+EDR | |
| LAN | IEEE 802.3 10Base-T, IEEE 802.3u 100Base-TX, IEEE 802.3ab 1000Base-T | |
| Modem | Data: 56 kbps (V.92) FAX: 14.4 kbps | |
| Sound | WAVE and MIDI playback, Stereo speaker, Intel® High Definition Audio subsystem support | |
| Security Chip | TPM (TCG V1.2 compliant) ^{*13} | |
| Card Slot | PC Card | Type I or Type II x 1 (3.3 V: 400 mA, 5 V: 400 mA) |
| | ExpressCard | ExpressCard/34 or ExpressCard/54 x 1 |
| | SD Memory Card ^{*14} | x 1, Data transfer rate = 8 MB per second ^{*15} |
| | Smart Card ^{*16} | x 1 |
| RAM Module Slot | 200-pin, 1.8 V, SO-DIMM, DDR2 SDRAM, PC2-4200 Compliant | |
| Interface | USB port (4-pin, USB 2.0) x 2, Serial Port (Dsub 9-pin male), Modem port (RJ-11), LAN port (RJ-45), External display port (Mini Dsub 15-pin female), Expansion Bus Connector (Dedicated 65-pin female), Microphone Jack (Miniature jack, 3.5 DIA, Stereo), Headphone Jack (Miniature jack, 3.5 DIA, Impedance 32 Ω, Output Power 4 mW × 2) | |
| Keyboard / Pointing Device | 87 keys / Touch Pad / Touchscreen (Anti-Reflection, Stylus (included) touch capable) | |
| Power Supply | AC adaptor or Battery pack | |
| AC Adaptor ^{*17} | Input: 100 V to 240 V AC, 50 Hz/60 Hz, Output: 15.6 V DC, 8.0 A | |

■ Main Specifications

| | |
|---|--|
| Battery Pack | Li-ion 11.1 V, 7.8 Ah |
| Operating Time ^{*18*19} | Approx. 6 hours to 9 hours ^{*20} (Approx. 8 hours ^{*21}) |
| Charging Time ^{*18} | Power on Approx. 4.5 hours |
| Clock Battery | Coin type lithium battery 3.0 V |
| Power Consumption ^{*22} | Approx. 40 W ^{*23} / Approx. 100 W (Maximum when recharging in the ON state) |
| Physical Dimensions (W × H × D) (including the carrying handle) | 303.5 mm × 43.6 - 60.1 mm × 293.3 mm {12.0" × 1.7 - 2.4" × 11.6"} |
| Weight (including the carrying handle) | Approx. 2.7 kg {Approx. 6.0 lb.} |
| Operation Environment | Temperature: 5 °C to 35 °C {41 °F to 95 °F} Humidity: 30% to 80% RH (No condensation) |
| Storage Environment | Temperature: -20 °C to 60 °C {-4 °F to 140 °F} Humidity: 30% to 90% RH (No condensation) |
| Operating System | Microsoft® Windows® XP Professional Service Pack 2 with Advanced Security Technologies (NTFS File System) |
| Utility Programs | DMI Viewer, Microsoft® Windows® Media Player 10, Adobe Reader, PC Information Viewer, SD Utility, Icon Enlarger, Loupe Utility, WinDVD™ 5 (OEM Version), B's Recorder GOLD8 BASIC, B's CLiP 6, Intel® Matrix Storage Manager, Intel® PROSet/Wireless Software ^{*11} , Bluetooth™ Stack for Windows® by TOSHIBA ^{*12} , Wireless Switch Utility, Hotkey Settings, Battery Recalibration, LAN Power-Saving Utility, Infineon TPM Professional Package ^{*24} Setup Utility, Hard Disk Backup Utility ^{*25} , Hard Disk Data Erase Utility ^{*25} |

■ Wireless LAN <Only for model with wireless LAN>

| | |
|--|---|
| Intel PRO / Wireless 3945 ABG (802.11 a + b + g) PCI Ex. 1/4 | |
| Data Transfer Rates ^{*26} | IEEE802.11a: 54/48/36/24/18/12/9/6 Mbps (automatically switched) IEEE802.11b: 11/5.5/2/1 Mbps (automatically switched) IEEE802.11g: 54/48/36/24/18/12/9/6 Mbps (automatically switched) |
| Standards Supported | IEEE802.11a/IEEE802.11b/IEEE802.11g |
| Transmission method | OFDM system, DSSS system |
| Wireless Channels Used | IEEE802.11a: Channels 36/40/44/48/52/56/60/64/149/153/157/161/165 IEEE802.11b/IEEE802.11g: Channels 1 to 11 |
| RF Frequency Band | IEEE802.11a: 5.18-5.32 GHz, 5.745-5.825 GHz IEEE802.11b/IEEE802.11g: 2.412-2.462 GHz |

*1 1MB = 1,048,576 bytes

*2 A segment of the main memory is allotted automatically depending on the computer's operating status. The size of the Video Memory cannot be set by the user.

*3 1GB = 1,000,000,000 bytes. Your operating system or some application software will report as fewer GB.

*4 The data transfer rate of DVD per 1X speed is 1,350 KB/s. The data transfer rate of CD per 1X speed is 150 KB/s.

*5 If an unbalanced disc (e.g., the balance has been displaced from the center) is inserted, the speed may become slower if there are large vibrations while the disc is rotating.

*6 Depending on the disc, the writing speed may become slower.

*7 Does not support DVD-RW Ver.1.0.

*8 DVD-RAM: Only non-cartridge type or removable cartridge type can be used.

*9 A 16,777,216 color display is achieved by using the dithering function.

*10 Maximum resolution depends on the specifications of the external display.

*11 Only for model with wireless LAN

*12 Only for model with Bluetooth

*13 For information on TPM, click [start] - [Run] and input "c:\util\drivers\tpm\README.pdf", and refer to the Installation Manual of "Trusted Platform Module (TPM)".

*14 Operation has been tested and confirmed using Panasonic SD Memory Cards with a capacity of up to 2 GB. The transfer rate using the SD Memory Card slot on this computer is 8 MB per second. (This is a theoretical value, and dif-

fers from actual speeds.)

The transfer rate is 8 MB per second even if you use an SD Memory Card that supports high-speed transfer rates. Operation on other SD equipment is not guaranteed.

This computer is not compatible with MultiMediaCards or SDHC Memory Cards. Do not insert these kinds of cards.

*15 Theoretical value and not the actual speed. The transfer rate does not become higher even if you use a card that supports the higher transfer rate.

*16 Only for model with Smart Card slot

*17 The AC adaptor is compatible with power sources up to 240 V AC adaptor. The computer is supplied with a 125 V AC compatible AC cord.

*18 Varies depending on the usage conditions.

*19 Measured with the LAN Power-saving function's Auto-off setting set to 1 minute.

*20 Measured using BatteryMark™ Version 4.0.1 (LCD brightness: Maximum - Minimum)

*21 Measured using MobileMark™ 2002 (LCD brightness: 60 cd/m²)

*22 Approx. 1.0 W when the battery pack is fully charged (or not being charged) and the computer is OFF.

Approx. 2.0 W when the Wake up from LAN has been enabled.

*23 Rated power consumption

*24 You need to install to use the feature.

*25 The Product Recovery DVD-ROM is required.

*26 These are speeds specified in IEEE802.11a+b+g standards. Actual speeds may differ.

2 Names and Functions of Parts

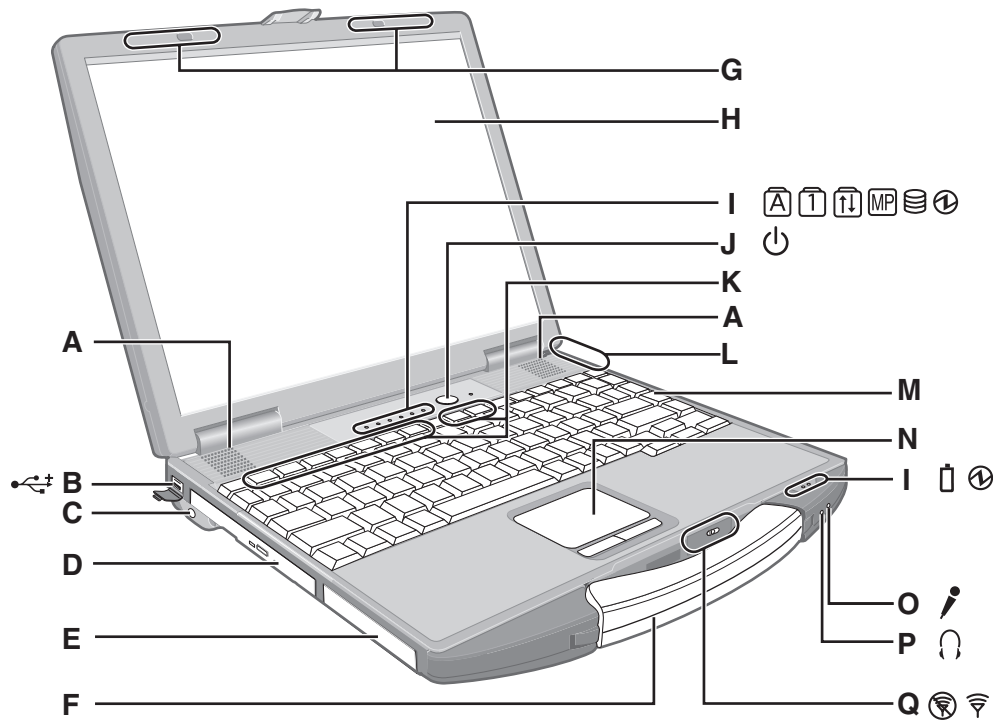

A : Speaker

→ Reference Manual "Key Combinations"

B : USB port

→ Reference Manual "USB Devices"

C : Stylus holder

D : Multimedia pocket

→ Reference Manual "Multimedia Pocket"

E : Hard disk drive

→ Reference Manual "Hard Disk Drive"

F : Carrying handle

G : Wireless LAN antenna

<Only for model with wireless LAN>

→ Reference Manual "Wireless LAN"

H : LCD

→ Reference Manual "Touchscreen"

I : LED indicator

: Caps lock

: Numeric key (NumLk)

: Scroll lock (ScrLk)

: Multimedia pocket device status or the second battery status

→ Reference Manual "Multimedia Pocket"
"Battery Power"

: Hard disk drive status

: Power status

(Off: Power off/Hibernation, Green: Power on, Blinking green: Standby, Blinking green rapidly: Cannot power on or resume due to low temperature.)

: Battery status

→ Reference Manual "Battery Power"

J : Power button

K : Function key

→ Reference Manual "Key Combinations"

L : Bluetooth antenna

<Only for model with Bluetooth>

→ Reference Manual "Bluetooth"

M : Keyboard

N : Touch pad

O : Microphone jack

You can use a stereo condenser microphone. Connecting other type of microphone may interrupt audio input or may cause a malfunction.

P : Headphone jack

You can connect headphones or amplified speakers. When they are connected, audio from the internal speakers is not heard.

Q : Wireless switch

→ Reference Manual "Wireless LAN" "Bluetooth"
"Wireless Switch Utility"

CAUTION

- Do not put a metallic object or magnetic media close to the speakers.

Right side

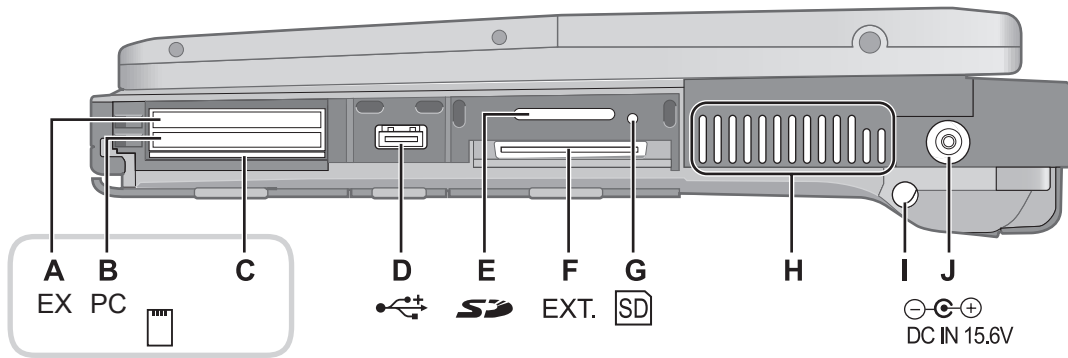

Rear side

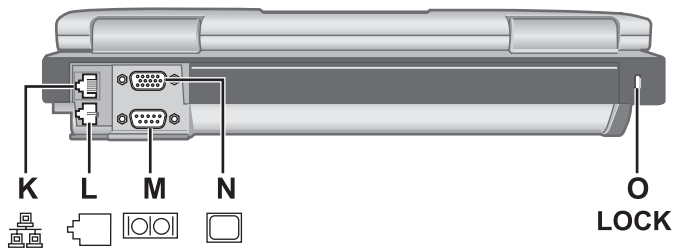

Bottom

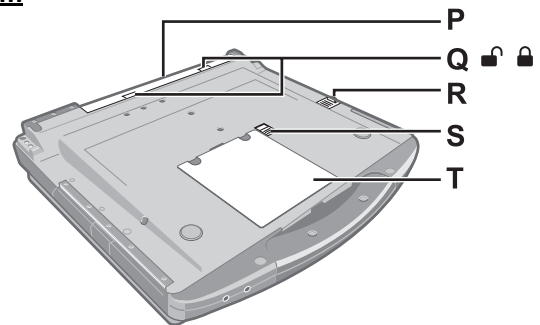

A : ExpressCard slot

→ Reference Manual "PC Card / ExpressCard"

B : PC Card slot

→ Reference Manual "PC Card / ExpressCard"

C : Smart Card slot

<Only for model with Smart Card slot>

→ Reference Manual "Smart Card"

D : USB port

→ Reference Manual "USB Devices"

E : SD Memory Card slot

→ Reference Manual "SD Memory Card"

F : Expansion bus connector

→ Reference Manual "Mini Port Replicator"

G : SD Memory Card indicator

(Blinking: During access or a password is requested)

→ Reference Manual "SD Memory Card"

H : Ventilation hole

I : Stylus holder

J : DC-IN jack

K : LAN port

→ Reference Manual "LAN"

L : Modem port

→ Reference Manual "Modem"

M : Serial port

N : External display port

→ Reference Manual "External Display"

O : Security lock

A Kensington cable can be connected.

For further information, read the manual that comes with the cable.

P : Battery pack

Q : Battery latch

R : Multimedia pocket release button

→ Reference Manual "Multimedia Pocket"

S : Hard disk drive latch

→ Reference Manual "Hard Disk Drive"

T : RAM module slot

→ Reference Manual "RAM Module"

CAUTION

- Do not block the ventilation hole with a thick cloth etc. Select a position with good ventilation.

3 Block Diagram

CF-74 Block Diagram

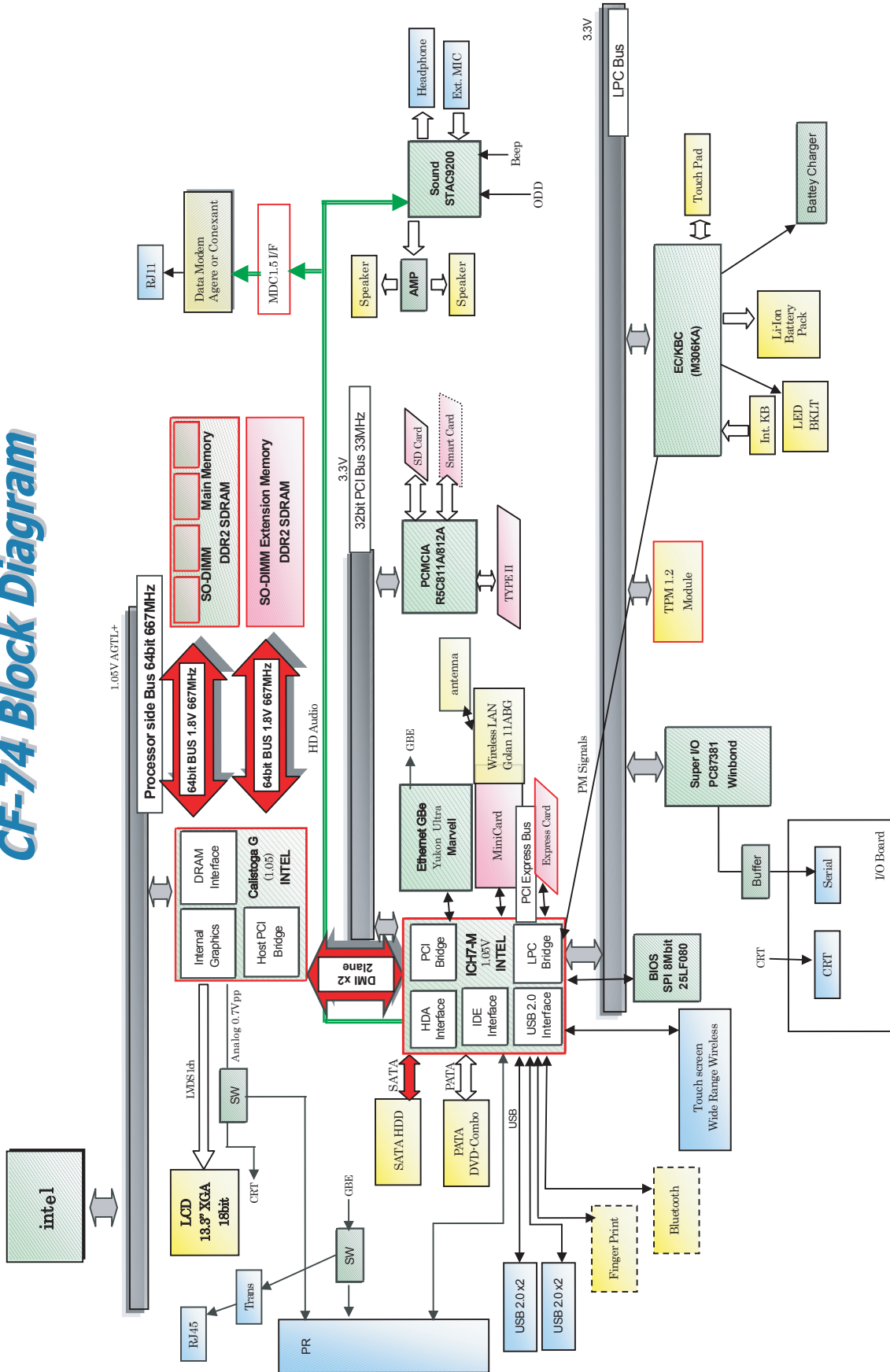

4 Diagnosis Procedure

4.1. Basic Procedures

The basic procedures for diagnosis, disassembly, and test of defective parts of a set to be repaired are summarized below. For details, refer to relevant pages in the Service Manual.

● Flow Chart

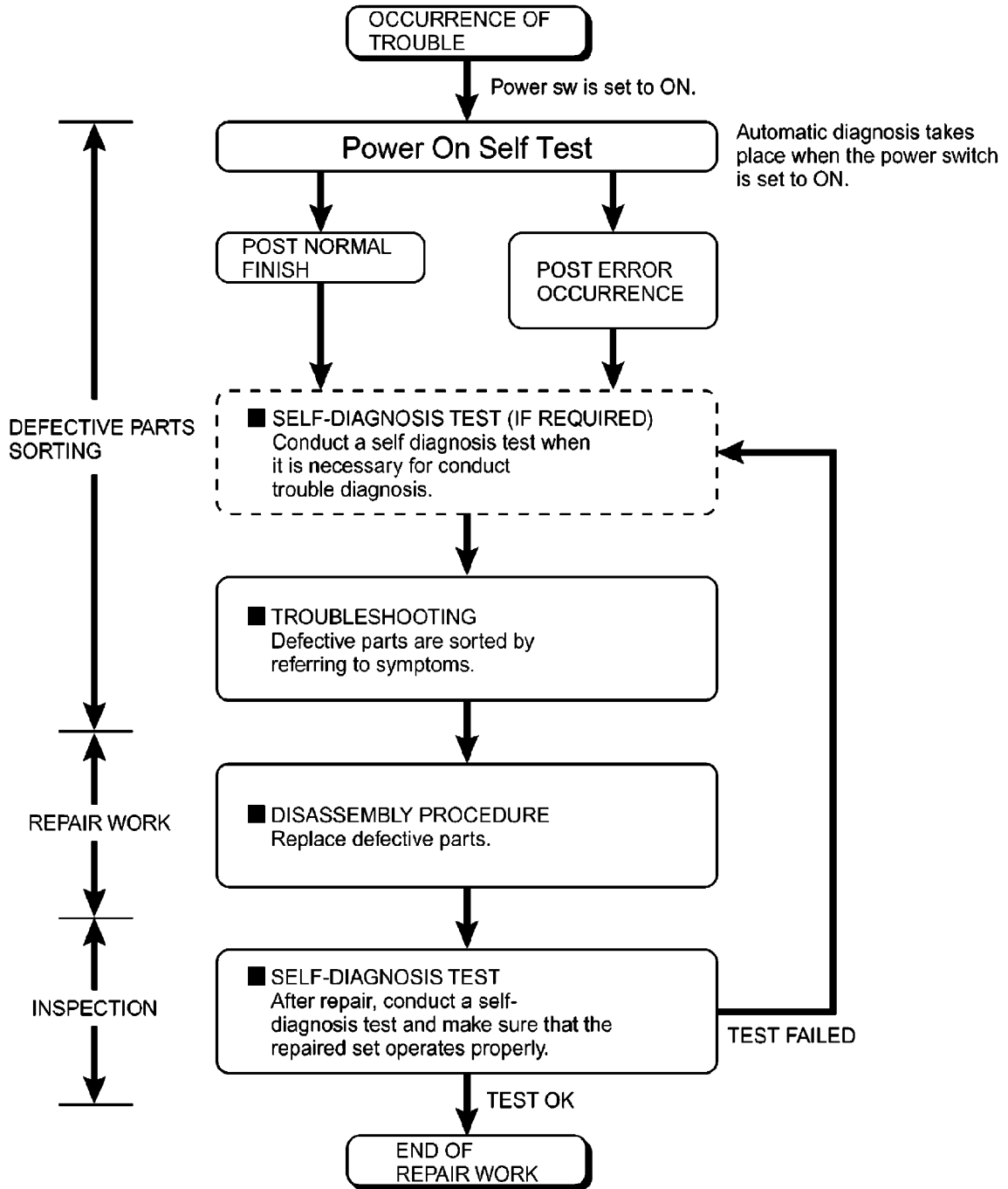

4.2. Troubleshooting

Please take note of the following two points with regard to troubleshooting:

1. Know-how of diagnosis upon occurrence of heavy troubles, e.g. 'Set cannot be turned ON', 'Set fails to start', 'No display on screen', etc.
2. Explanation of each trouble, mainly symptom of trouble in operation.

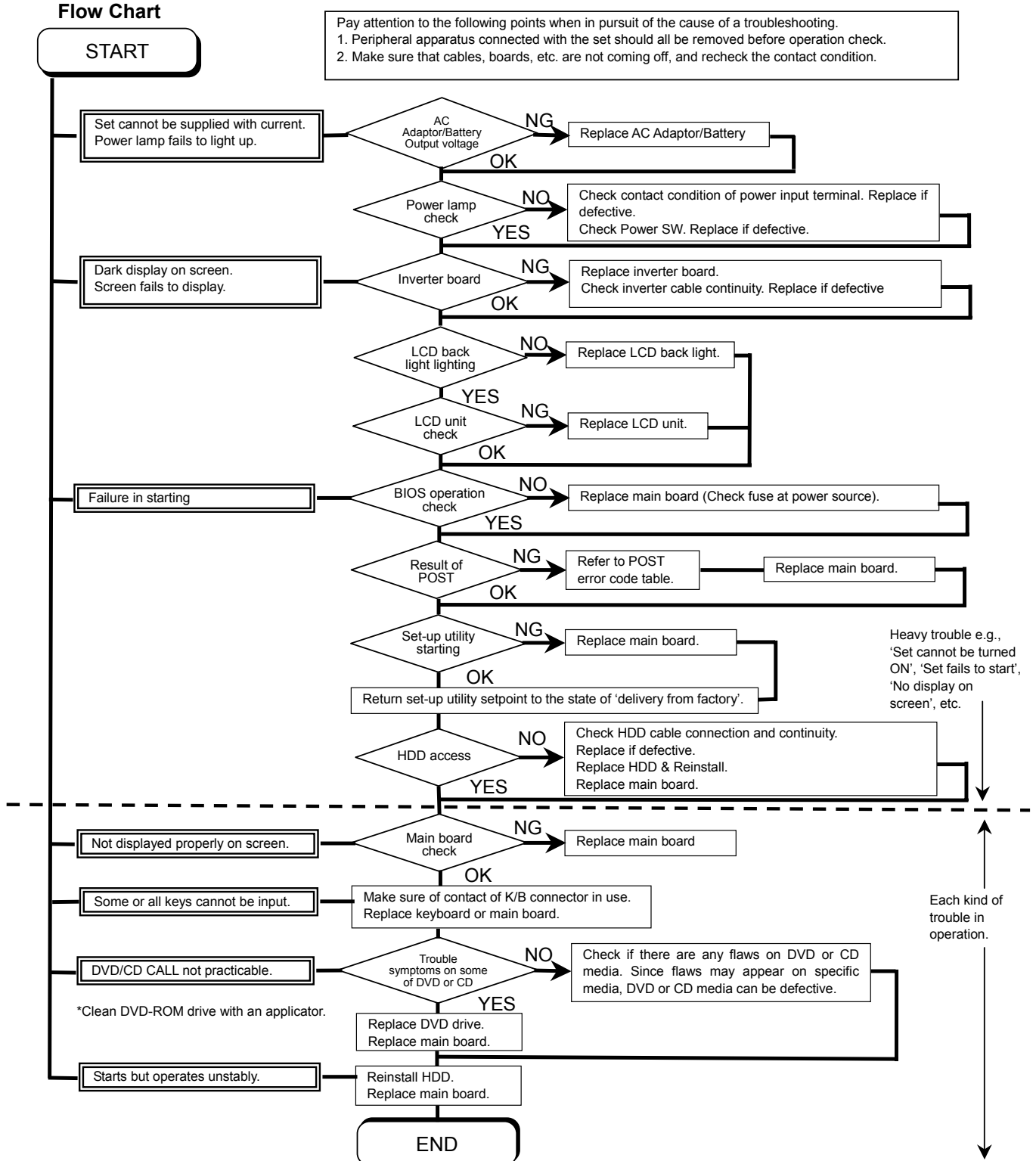

5 Power-On Self Test (Boot Check)

Outline of POST

The set has a boot check function called POST (Power-On Self Test) in it. The condition of the main body is diagnosed by checking beep sound or error code.

- StartTest begins automatically when power switch is set to ON.
- Normal finishAfter memory checking, a beep sound is issued once and the set is placed into automatic stop.

Note: If no error occurs, nothing is displayed. (No display of OK, etc.)

Error Diagnosis by Checking Beep Signal Sound

The beep sound is as follows:



(Length of bar shows length of sound.)

■ = long sound (about 0.4 sec.), ■ = short sound (about 0.2 sec.), Length between sounds is about 0.1 sec.

● Table of errors classified by beep sounds

| Diagnosis | Beep signal sound | Error message |
|------------|-------------------|-----------------------------------|
| Main board | 1(long sound)-2 | BIOS ROM error |
| | 1-2-2-3 | BIOS ROM error |
| | 1-3-1-1 | RAM error |
| | 1-3-1-3 | Keyboard controller error |
| | 1-3-4-1 | RAM error |
| | 1-3-4-3 | RAM error |
| | 1-4-1-1 | RAM error |
| | 2-1-2-3 | BIOS ROM error |
| | 2-2-3-1 | Occurrence of unexpected offering |

(Note) A beep sound is also issued in case of other I/O trouble.

6 List of Error Codes <Only when the port replicator is connected>

The following is a list of the messages that BIOS can display. Most of them occur during POST. Some of them display information about a hardware device, e.g., the amount of memory installed. Others may indicate a problem with a device, such as the way it has been configured. Following the list are explanations of the messages and remedies for reported problems. If your system displays one of except the messages marked below with an asterisk (*), write down the message and contact Panasonic Technical Support. If your system fails after you make changes in the Setup menus, reset the computer, enter Setup and install Setup defaults or correct the error.

0200 Failure Fixed Disk

Fixed disk in not working or not configured properly. Check to see if fixed disk is attached properly. Run Setup. Find out if the fixed-disk type is correctly identified.

0210 Stuck key

Stuck key on keyboard.

0211 Keyboard error

Keyboard not working.

0212 Keyboard Controller Failed

Keyboard controller failed test. May require replacing keyboard controller.

0213 Keyboard locked - Unlock key switch

Unlock the system to proceed.

0230 System RAM Failed at offset : *nnnn*

System RAM failed at offset *nnnn* of in the 64k block at which the error was detected.

0231 Shadow RAM Failed at offset : *nnnn*

Shadow RAM failed at offset *nnnn* of the 64k block at which the error was detected.

0232 Extended RAM Failed at offset : *nnnn*

Extended memory not working or not configured properly at offset *nnnn*.

0250 System battery is dead - Replace and run SETUP

The CMOS clock battery indicator shows the battery is dead. Replace the battery and run Setup to reconfigure the system.

***0251 System CMOS checksum bad - Default configuration used**

System CMOS has been corrupted or modified incorrectly, perhaps by an application program that changes data stored in CMOS. The BIOS installed Default SETUP Values. If you do not want these values, enter Setup and enter your own values. If the error persists, check the system battery or contact Panasonic Technical Support.

0260 System timer error

The timer test failed. Requires repair of system board.

0270 Real time clock error

Real-time clock fails BIOS test. May require board repair.

***0280 Previous boot incomplete - Default configuration used**

Previous POST did not complete successfully. POST loads default values and offers to run Setup. If the failure was caused by incorrect values and they are not corrected, the next boot will likely fail. On systems with control of **wait states**, improper Setup settings can also terminate POST and cause this error on the next boot. Run Setup and verify that the wait-state configuration is correct. This error is cleared the next time the system is booted.

0281 Memory Size found by POST differed from EISA CMOS

Memory size found by POST differed from EISA CMOS.

02D0 System cache error - Cache disabled

Contact Panasonic Technical Support.

02F0: CPU ID:

CPU socket number for Multi-Processor error.

02F4: EISA CMOS not writable

ServerBIOS2 test error: Cannot write to EISA CMOS.

02F5: DMA Test Failed

ServerBIOS2 test error: Cannot write to extended DMA (Direct Memory Access) registers.

02F6: Software NMI Failed

ServerBIOS2 test error: Cannot generate software NMI (Non-Maskable Interrupt).

02F7: Fail - Safe Timer NMI Failed

ServerBIOS2 test error: Fail-Safe Timer takes too long.

***device* address Conflict**

Address conflict for specified *device*.

Allocation Error for: *device*

Run ISA or EISA Configuration Utility to resolve resource conflict for the specified *device*.

Failing Bits : *nnnn*

The hex number *nnnn* is a map of the bits at the RAM address which failed the memory test.

Each 1 (one) in the map indicates a failed bit. See error 230,231 or 232 for offset address of the failure in System, Extended or Shadow memory.

Invalid System Configuration Data

Problem with NVRAM (CMOS) data.

I/O device IRQ conflict

I/O device IRQ conflict error.

Operating System not found

Operating system cannot be located on either drive A: or drive C:. Enter Setup and see if fixed disk and drive A: are properly identified.

Parity Check 1 *nnnn*

Parity error found in the system bus. BIOS attempts to locate the address and display it on the screen. If it cannot locate the address, it displays ????. Parity is a method for checking errors in binary data. A parity error indicates that some data has been corrupted.

Parity Check 2 *nnnn*

Parity error found in the I/O bus. BIOS attempts to locate the address and display it on the screen. If it cannot locate the address, it displays ????.

Press <F1> to resume, <F2> to Setup

Displayed after any recoverable error message. Press <F1> to start the boot process or <F2> to enter a Setup and change the settings. Write down and follow the information shown on the screen.

7 Self Diagnosis Test

As for the self-diagnosis test(PC-Diagnostic utility) to use this model, a standard test and the enhancing test by the module of the main body building in are possible.

- Notes To skip BIOS password
Use <Ctrl>+<F10> key to skip BIOS password or authentication of fingerprint.
This key is only for entering DIAG mode. Not available to boot the computer.
If customer set "HDD Lock", the DIAG program cannot perform HDD test.
*This key is for service purpose only. Do not disclose this information to unrelated others.

1. Beginning of self-diagnosis test

1-1. Setting of content of setup

1. The power supply of the computer is turned on.
2. " F2 " is pushed on the screen of "Panasonic" while " press <F2 to enter Setup> " is displayed.
3. The setup utility starts and then takes notes of the content of the BIOS setup of present set.
4. " F9 " is pushed, " Yes" is selected on the screen of " Is the default value loaded? ", and " Enter" is pushed.
5. " F10 " is pushed.
6. " Yes" is selected on the screen of the setup confirmation, and " Enter" is pushed.
7. The computer starts automatically.

Attention

- If the device which can be set is set to "Invalidity" by "Advanced" or "Security" menu, becomes an error by "PC-Diagnostic utility".
(It is judged that the device which can be set to "Invalidity" by "Main" menu such as "Flat pad" is normal if the controller operates normally though sets to "Invalidity" by the setup.)
- In the model with built-in DVD of the USB connection, even if DVD is normal, becomes an error if legacy USB is set to "Invalidity"

1-2. When you execute an automatic test

1. "Ctrl" + "F7" is pushed while the "Panasonic" start screen is displayed after the computer is started.
2. The test of all devices begins automatically by "PC-Diagnostic utility"s starting.

Attention

- It is a test which the customer who bought PC can execute. (As for HDD, the enhancing test is also possible.)
- A flat pad does not work for a while after starting "PC-Diagnostic utility".
- The movement of a flat pad might become abnormal If after RAM begins from the CPU/System test, a flat pad will be operated in about 30 seconds. In that case, restarts pushing "Alt" + "Ctrl" + "Del" key. Or, please start "PC-Diagnostic utility" again after doing the power supply switch in the slide, and turning off the power supply.

1-3. When you execute the enhancing test

1. Please let me discontinue diagnosing clicking  to end an automatic test.
2. Please click on the character of "D" "PC-Diagnostic utility" on the screen while pushing both of right "Shift" and left "Shift" keys.



3. All devices which can select the enhancing test make the setting of the enhancing test possible.
4. The district device is made "FULL" display (enhancing test).
5. The test begins clicking .

*Please refer to item 4 for the error result of each test and the division of the breakdown part.

2. Operation of PC-Diagnostic Utility

- Only the device which can be inspected on the entire screen is displayed.
- The item does not appear when the device of wireless LAN etc. is not physically connected.
- The movement of the item must use an arrow key or a flat pad.

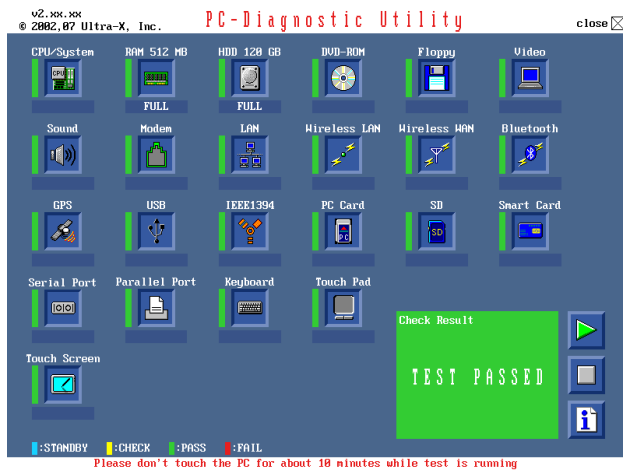

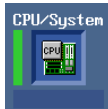

- As for the device under the diagnosis, blue and yellow are alternately displayed at the left of the icon.
- The diagnosis result of the device greens at the left of the icon when it is normal, and becomes red when abnormal.



- When the test of all devices ends, the test result is displayed under the right of the screen.



- Please click  while diagnosing when being stop on the way by the time the test of all devices ends.
- Please click  when you restart "PC-Diagnostic utility".

*Each device is tested from the beginning, and it is not possible to restart on the way.

2-1. Selection of tested device

-To test only a specific device, "Test" and "Do not test" of each device can be selected.

-The device which can select the enhancing test changes in order of "The standard is tested" and "Do not test" whenever the device icon is clicked.



Start the standard test



Do not test

Please begin testing clicking  if the selection of the tested device ends.

2-2. "PC-Diagnostic utility" End method

When of "Close" on the right of the screen is clicked, the computer reactivates automatically. Or, the power supply switch is done in the slide and the power supply is turned off.

2-3. The content of the setup is returned to the setting of the user

1. Turned on the computer.
2. "F2" is pushed on the screen while "Press<F2>to enter Setup" is displayed of "Panasonic".
3. Push "F10", and on the screen of "Is the change in the setting preserved and do end?"and then "Yes" is selected, and "Enter" is pushed.
4. The computer reactivates automatically.
5. The end option is chosen by the start menu, and the power supply of the computer is turned off.

Standard at test time

All devices other than RAM and HDD ----- about 1 minute

RAM standard test ----- 1 - 2 minutes

HDD standard test ----- 2 - 3 minutes

HDD enhancing test (60GB) ----- about 40 minutes

Ex.The standard when the standard <all device> is tested becomes $1+2+3=6$ minutes.

- There is greatly a difference from RAM test when the memory is increased according to the performance of the memory occasionally.
- Moreover, when the main body of PC under the test is a high temperature, it occasionally takes time.
- There is greatly a difference from HDD according to the performance of the drive occasionally.

7.1. Test Item and Division of trouble

| Test item | Stanard | Enhancing | Content of standard test | Content of enhancing test | Place with possibility of breakdown |
|--------------|---------|-----------------|--|--|--|
| CPU / SYSTEM | ○ | — | CPU is shifted to protected mode, and "Violation of the paging", "Operation of the violation of a privileged instruction", and DMA, INT, TIMER, and the RTC operation are confirmed. | — | CPU / Main board |
| RAM | ○ | — | All memory space is tested in a special memory access pattern based on "R.S.T . technology". | — | Memory / Mainboard |
| HDD | ○ | ○ | The record area frequently accessed with Microsoft Windows XP to test in about two minutes regardless of points of HDD is emphatically tested. | All record area is tested. | HDD / Mainboard / Cable / Connector |
| MODEM | ○ | — | It is confirmed not to find abnormality in the AC97 modem controller. | — | MODEM/ Mainboard |
| Wireless LAN | ○ | — | It is confirmed not to find abnormality in the Wireless LAN modem controller. | — | Wireless LAN board / Connector / Mainboard |
| Sound *5 | ○ | — | | | |
| USB | ○ | ○ ^{*1} | It is confirmed not to find abnormality in the USB controller. | It is confirmed not to find abnormality in the wiring between the USB controller and the connector by confirming the connection of the USB equipment connected with the USB connector. | Mainboard / Connector |
| LAN | ○ | ○ ^{*2} | It is confirmed not to find abnormality in the LAN controller. | It is confirmed not to find abnormality in the wiring between the controller and the connector by connecting to HUB with LAN cable. | Mainboard / Connector |
| PC Card | ○ | — | It is confirmed not to find abnormality in the CardBus controller. | — | Mainboard |
| SD | ○ | — | It is confirmed not to find abnormality in the SD controller. | — | Mainboard |
| Keyboard | ○ | ○ ^{*3} | It is confirmed not to find abnormality in keyboard controller's keyboard interface. | The key is actually input, and the operation is displayed on the screen. | Mainboard / Keyboard |
| Touch Pad | ○ | ○ ^{*4} | Whether keyboard controller's mouse interface operates normally is confirmed. | The operation is actually displayed on the screen by operating the touch pad. | Mainboard / Touch Pad |
| DVD-ROM | ○ | ○ ^{*6} | The drive is normally reset, and it is accessible is confirmed. | It is confirmed to be able to read media normally. | Mainboard / Touch Pad |

| Test Item | Standard | Enhanced | Content of Standard Test | Content of Extend Test | The place with possibility of breakdown |
|---------------|----------|----------|--|--|--|
| Touch Screen | ○ | ○ | It is confirmed not to find abnormality in the USB connection of Touch Screen. This test cannot find abnormality of Touch Screen. | Perform Touch Screen functionality practically. Operator has to judge PASS/FAIL with test result. | Main board/ Touch Screen |
| Bluetooth | ○ | | It is confirmed not to find abnormality in the connection of Main board and Bluetooth module. | — | Bluetooth cable |
| Wireless WAN | ○ | — | It is confirmed not to find abnormality in the connection of Main board and Wireless WAN module. | — | WWAN cable |
| Floppy | ○ | — | It is confirmed not to find abnormality in the legacy FD drive. This test cannot find abnormality of mechanical breakdown. (e.g., Head, Motor) | — | FD Drive/ Main board (Super I/O)/ FDD cable FDD connector |
| Video | ○ | — | It is confirmed not to find abnormality in access to VRAM with VESA. The PC which uses main memory as VRAM may fail with main memory failure. | — | Main board (Chipset, Graphic Controller)/ Memory |
| GPS | ○ | — | It is confirmed not to find abnormality in the connection of Main board and GPS | — | GPS cable |
| IEEE1394 | ○ | — | It is confirmed not to find abnormality in the IEEE1394 controller. | — | Main board (IEEE1394 Controller) |
| Express Card | — | ○ | — | It is confirmed not to find abnormality in the wiring between Chipset and Express Card. | Main board (Chipset)/ Express Card Connector |
| Smart Card | ○ | — | It is confirmed not to find abnormality in the Smart Card controller. | — | Main board (Smart Card Controller) |
| Serial Port | ○ | ○ *7 | It is confirmed not to find abnormality of Super I/O UART function. This test cannot find lack of wiring between Super I/O and Serial Connector. | It is confirmed not to find abnormality in the wiring between Super I/O and Serial Connector. This test cannot find failure of cable characteristic and device problems. | Main board (Super I/O)/ Serial Connector |
| Parallel Port | ○ | ○ *8 | It is confirmed not to find abnormality of Super I/O parallel function. This test cannot find lack of wiring between Super I/O and Parallel Connector. | It is confirmed not to find abnormality in the wiring between Super I/O and Parallel Connector. This test cannot find failure of cable characteristic and device problems. | Main board (Super I/O)/ Parallel Connector |

*1 Please connect the USB device with the port (USB connector) which wants to test before the tests.

*2 Please connect LAN port with LAN HUB with LAN cable before the tests.

*3 The operator actually inputs the key, and the operator judges PASS/FAIL of the test.

*4 The operator actually operates the mouse, and the operator judges PASS/FAIL of the test.

*5 It is not abnormal though the sound is emitted from the speaker while testing.

※ When the test result is PASS, trouble is thought by not hearing of the sound under the test from the speaker and the headphone by the wiring of the audio output system.

*6 Please set DVD/CD media in the drive before the tests.

*7 Please set a Special Loop Back Connector Tool at serial connector for Enhanced Test. (This Connector Tool is same as the one used before.)

*8 Please set a Special Loop Back Connector Tool at parallel connector for Enhanced Test. (This Connector Tools is same as the one used before.)

8 Wiring Connection Diagram

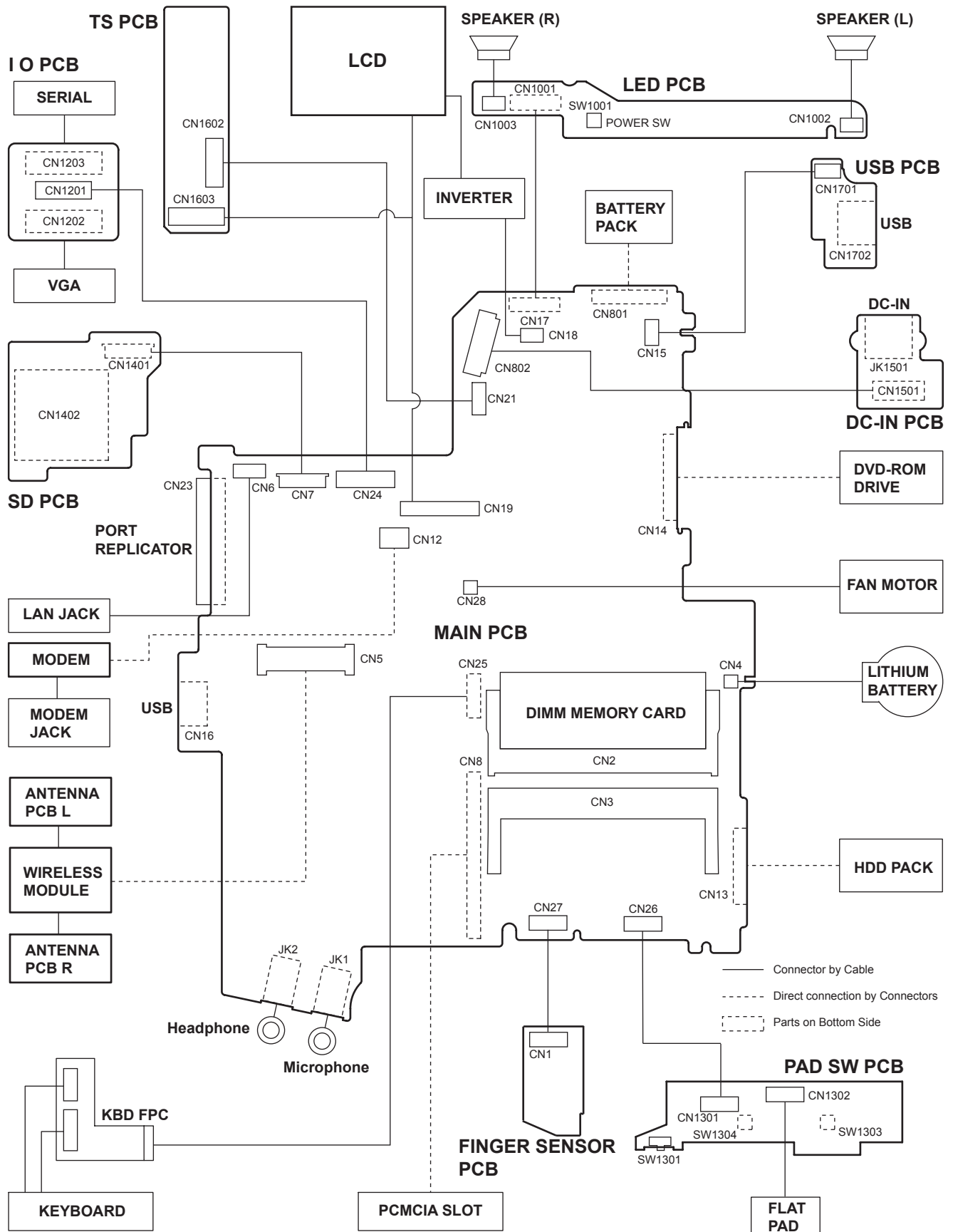

9 Disassembly/Reassembly

Note:

Power off the computer. Do not shut down to the Suspend or hibernation mode.

Do not add peripherals while the computer is in the Suspend or hibernation mode; abnormal operation may result.

9.1. Disassembly Instructions

9.1.1. Preparation

Before disassembling, be sure to make the following preparations.

- Shut down Windows and turn off the power.
- Disconnect the AC adaptor.
- Remove the optional DIMM memory card and PCMCIA card if they are connected.
- Remove other devices if they are connected.

Attention:

- Please execute writing BIOS ID when you exchange the Main Board.
- You cannot reuse the Conductive Clothes and the heat dissipating parts such as Sheet and Rubber. Use new parts.

9.1.2. Removing the Battery Pack, the HDD Unit and the DVD-ROM Drive Unit

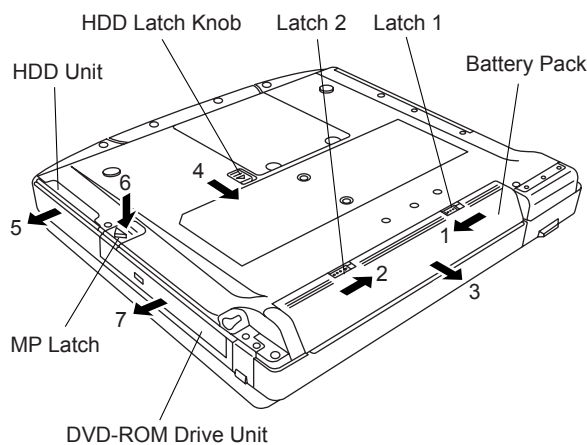

Battery Pack

1. Slide the Latch 1 to unlock. (1)
2. Slide the Latch 2 (2), and then without releasing it, slide and remove the Battery Pack. (3)

HDD Unit

1. Slide the HDD Latch Knob (4), and then without releasing it, slide and remove the HDD Unit. (5)

DVD-ROM Drive Unit

1. Push the MP Latch (6), and then without releasing it, slide the DVD-ROM Drive Unit. (7)

9.1.3. Removing the HDD

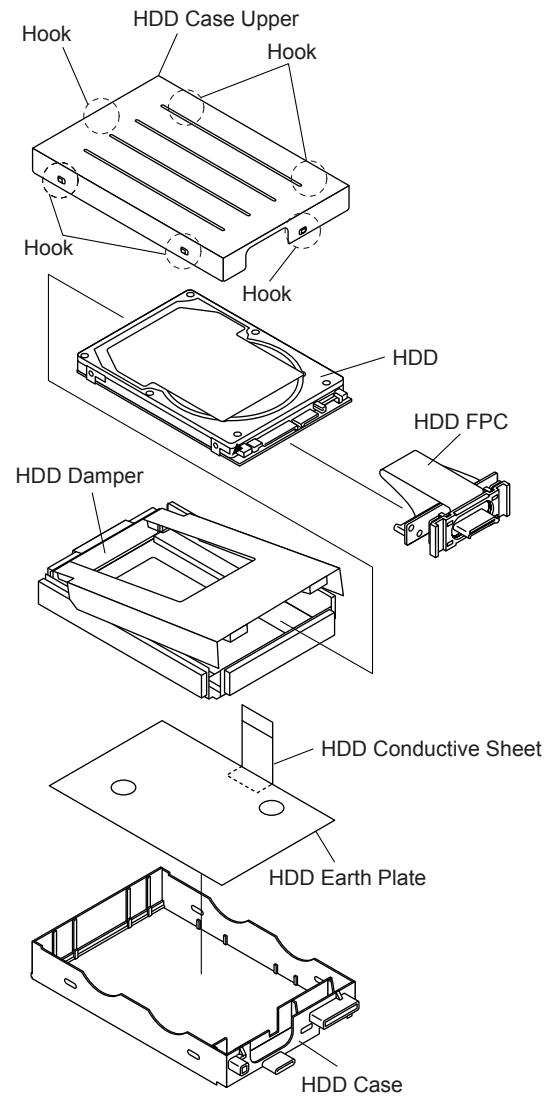

1. Remove the six Hooks, and remove the HDD Case Upper.
2. Remove the HDD Damper.
3. Disconnect the HDD from the HDD FPC.
4. Remove the HDD Conductive Sheet and HDD Earth Plate.

9.1.4. Removing the DIMM Memory Card

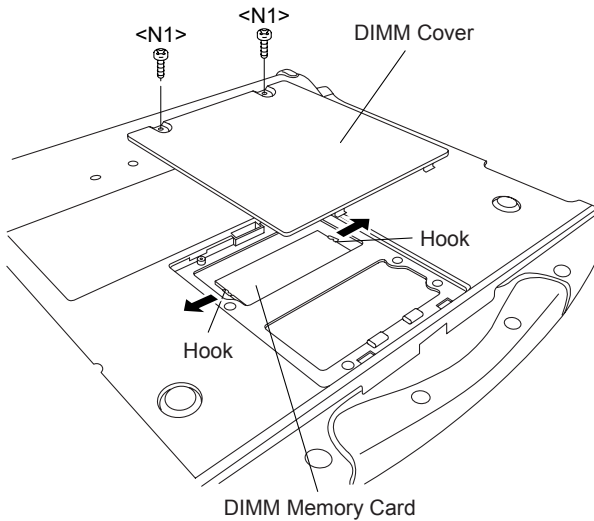

1. Remove the two Screws <N1>, and remove the DIMM Cover.
2. Open the right and left Hooks of the DIMM Memory Card outward, and remove the DIMM Memory Card.

Screws <N1>: XSB2+3FNL

9.1.5. Removing the Keyboard

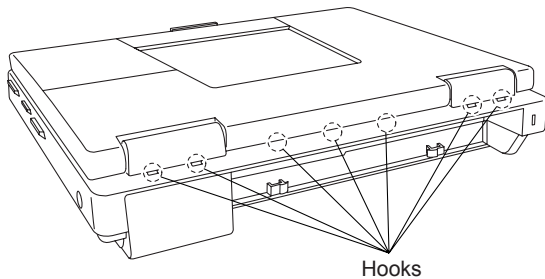

1. Release the seven Hooks fixing the rear side of the Center Cover.

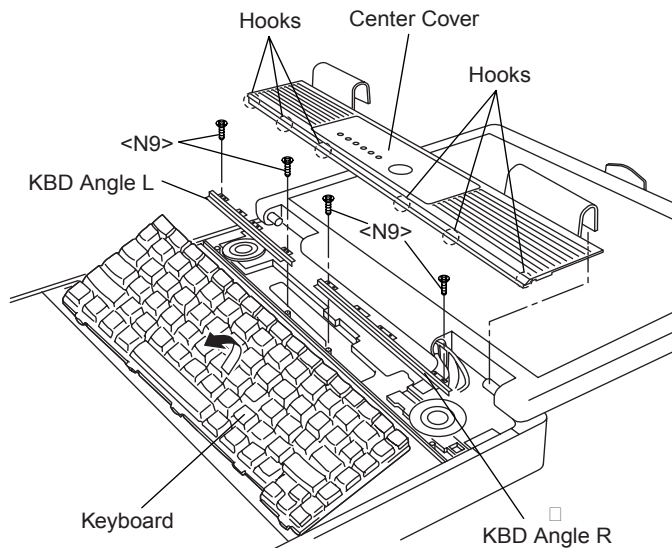

2. Lift the upper part of the Center Cover and draw it backward, release the six Hooks fixing the front side of the Center Cover, and then remove the Center Cover.
3. Remove the four Screws <N9> and the KBD Angle L and R.
4. Lift the upper part of the Keyboard and draw it backward, and then turn the Keyboard over forward.

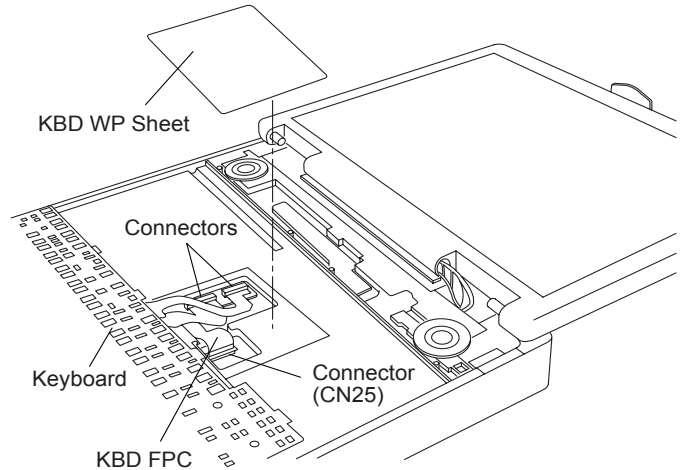

5. Remove the KBD WP Sheet.
6. Disconnect the two KBD Cables from the two Connectors (KBD FPC).
7. Remove the Keyboard.
8. Disconnect the Cable from the Connector (CN25).
9. Remove the KBD FPC,

Screws <N9>: DFHE5025XA

9.1.6. Removing the Speaker and the LED PCB

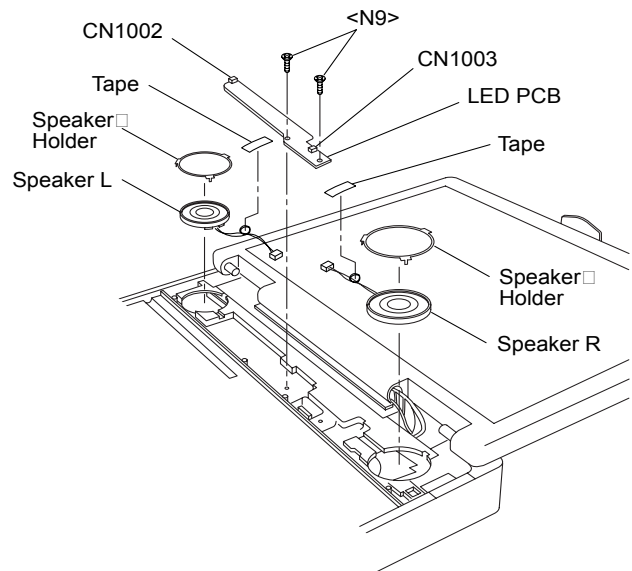

1. Remove the two Speaker Holders.
2. Remove the two tapes, and disconnect the two Speaker Cables from the two Connectors (CN1002, CN1003)
3. Remove the Speaker L and R.
4. Remove the two Screws <N9>, and Remove the LED PCB.

Screws <N9>: DFHE5025XA

9.1.7. Removing the Handle Ass'y

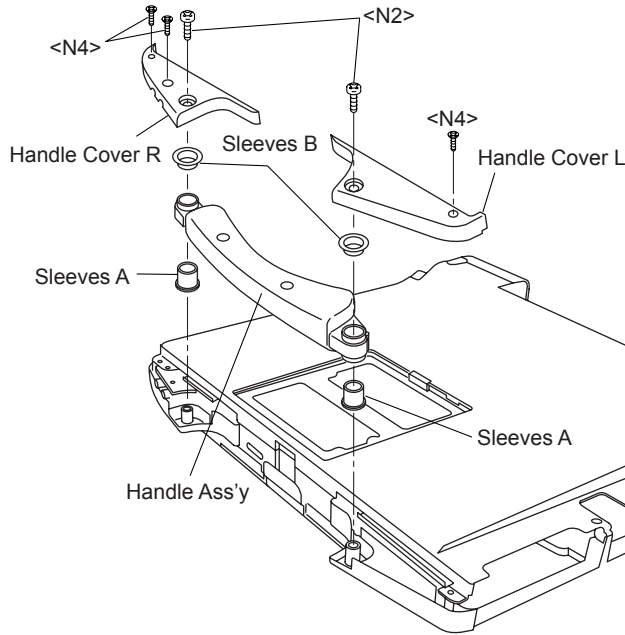

1. Remove the two Screws <N2>.
2. Remove the three Screws <N4>, and remove the Handle Cover L and R.
3. Remove the two Sleeves A, Handle Ass'y and two Sleeves B.

Screws <N2>: DRHM4+10FKS

Screws <N4>: DRSB2+6FKL

9.1.8. Removing the Bottom Case

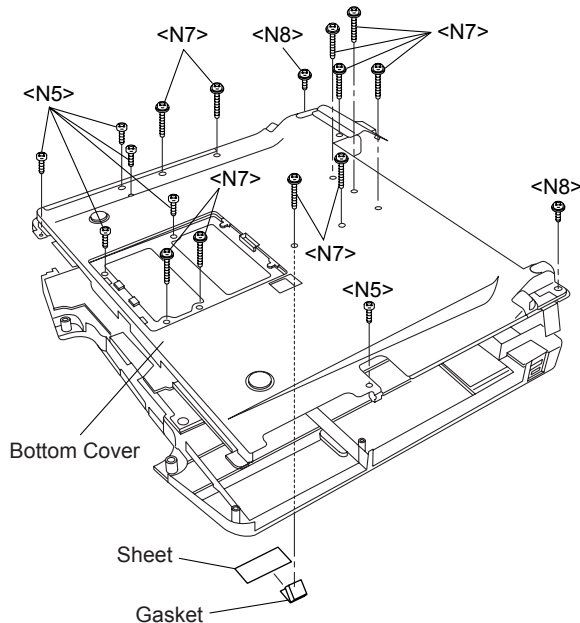

1. Remove the six Screws <N5>.
2. Remove the ten Screws <N7>.
3. Remove the two Screws <N8>.
4. Open the Lid Rubbers and remove the Bottom Cover.
5. Remove the Sheet and Gasket.

Screws <N5>: DXSB2+6FNL

Screws <N7>: DXYN2+J16FNL

Screws <N8>: DXYN2+J8FNL

9.1.9. Removing the Wireless Module and MDC Module

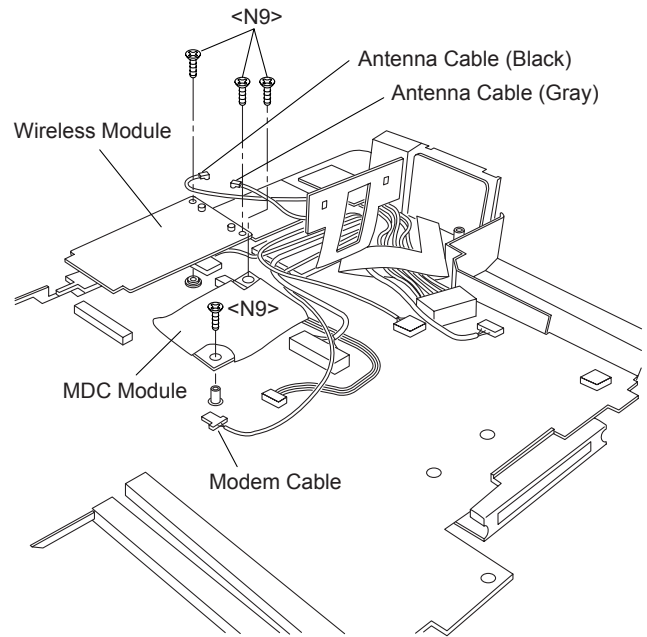

1. Remove the two Antenna Cables from the two Connectors.
 - Antenna Cable (Black): MAIN Connector
 - Antenna Cable (Gray): AUX Connector
2. Remove the two Screws <N9>.
3. Remove the Wireless Module.
4. Remove the two Screws <N9>.
5. Disconnect the Modem Cable from the Connector.
6. Remove the MDC Module.

Screws <N9>: DFHE5025XA

9.1.10. Removing the Main PCB

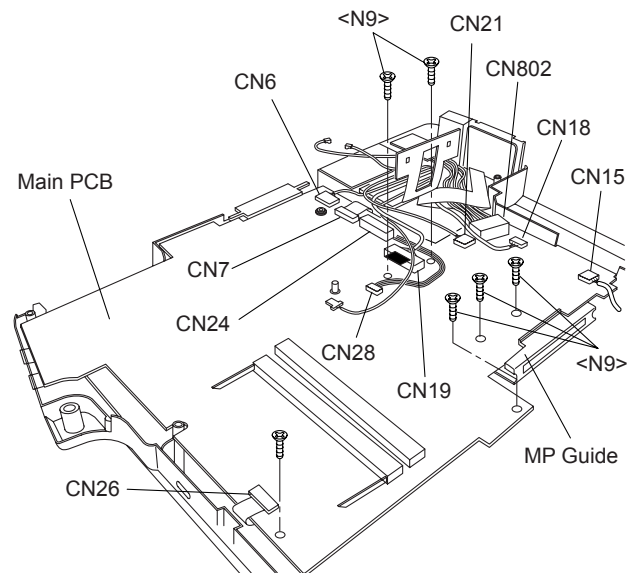

Note:

After replacing the Main Board, rewrite the BIOS ID.

1. Disconnect the ten Cables from the ten Connectors (CN6, CN7, CN24, CN19, CN28, CN21, CN802, CN18, CN15, CN25).
2. Remove the six Screws <N9>.
3. Remove the Main PCB.
4. Remove the MP Guide.

Screws <N9>: DFHE5025XA

9.1.11. Removing the PC Card Ejector and Lithium Battery

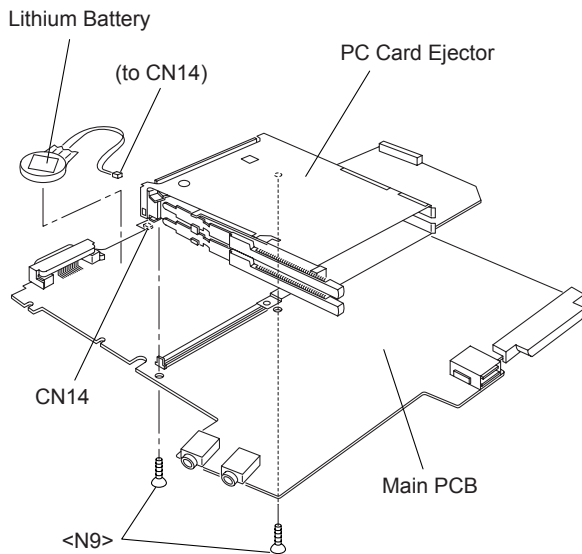

1. Remove the two Screws <N9>.
2. Remove the PC Card Ejector.
3. Disconnect the Cable from the Connector (CN14).
4. Remove the Lithium Battery.

Screws <N9>: DFHE5025XA

9.1.12. Removing the DC-IN PCB and I/O PCB

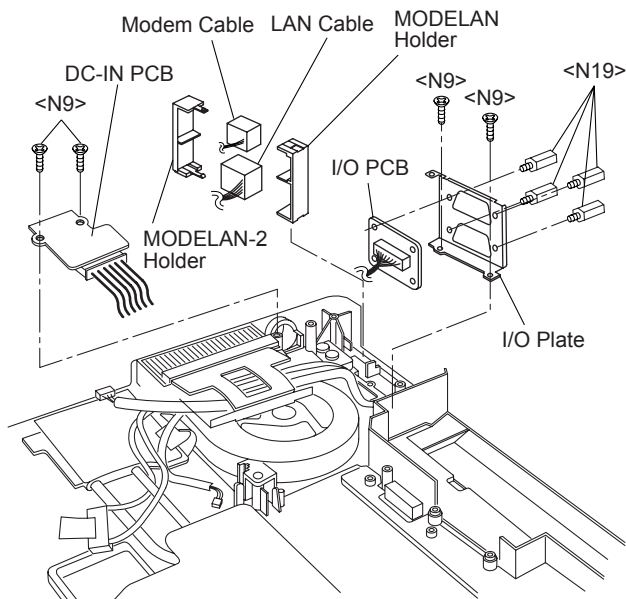

1. Remove the two Screws <N9>.
2. Remove the DC-IN PCB.
3. Remove the two Screws <N9>.
4. Remove the four Screws <N19>, and then the I/O PCB from the I/O Plate.
5. Remove the Modem Cable and LAN Cable from the MODELAN Holders.

Screws <N9>: DFHE5025XA

Screws <N19>: DFHE5035ZB

9.1.13. Removing the FAN Motor and SD PCB

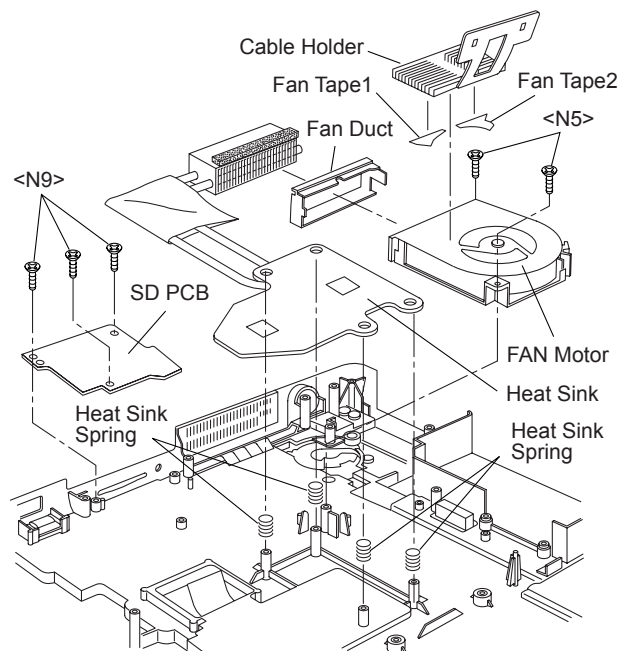

1. Remove the Cable Holder.
2. Remove the two Screws <N5>.
3. Remove the FAN Motor.
4. Remove the Heat Sink, Fan Duct, and the four Heat Sink Springs.
5. Remove the three Screws <N9>.
6. Remove the SD PCB.

Screws <N5>: DXSB2+6FNL

Screws <N9>: DFHE5025XA

9.1.14. Removing the USB PCB

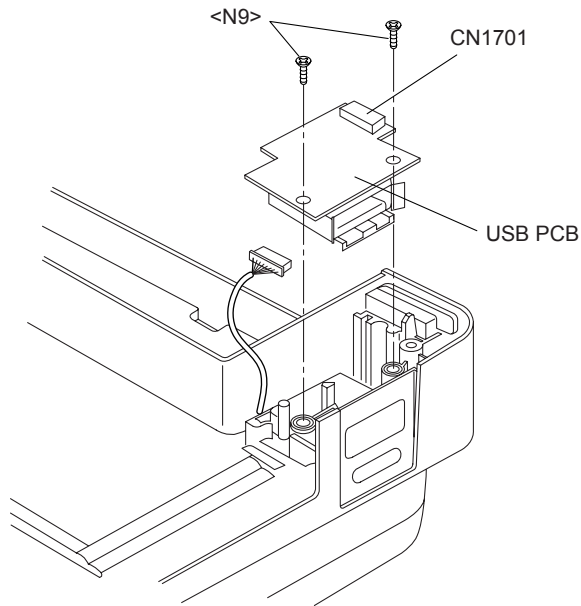

1. Disconnect the Cable from the Connector (CN1701).
2. Remove the two Screws <N9>.
3. Remove the USB PCB.

Screws <N9>: DFHE5025XA

9.1.15. Removing the Display unit

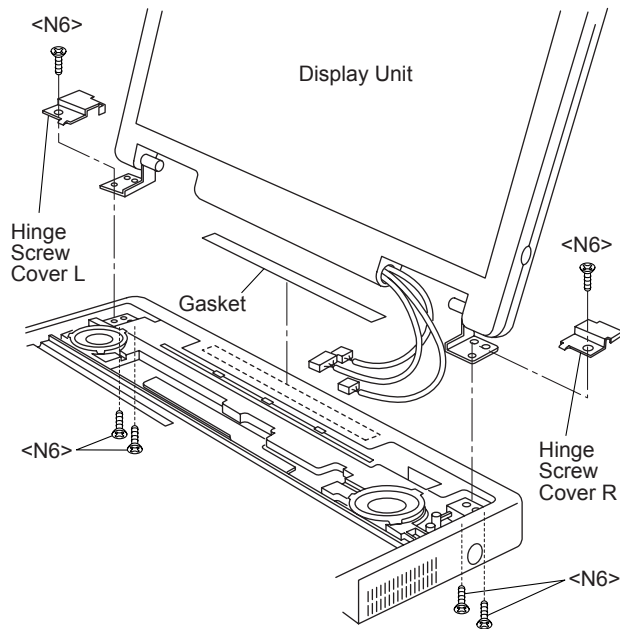

1. Remove the four Screws <N6> from the computer bottom side.
2. Remove the two Screws <N6> from the computer upper side.
3. Remove the Display Unit.
4. Remove the Hinge Screw Cover L and R.
5. Remove the Gasket.

Screws. <N6>: DXSB3+6FNL

9.1.16. Removing the LCD Front Cabinet

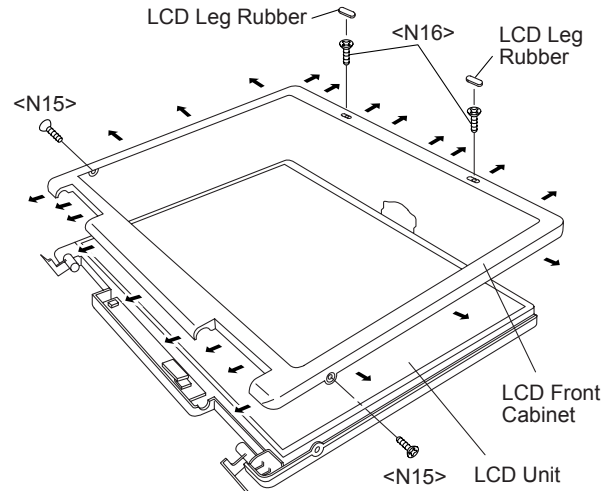

1. Remove the two LCD Leg Rubbers, and then the two Screws <N16>.
2. Remove the two Screws <N15>.
3. Release the 23 Hooks joining the LCD Front and Rear Cabinet on the LCD Front Cabinet outward. (See the Figure),
4. Remove the LCD Front Cabinet.

Screws <N15>: DRHM0075ZA

Screws <N16>: DXQT2+G4FCL

9.1.17. Removing the LCD and the Inverter

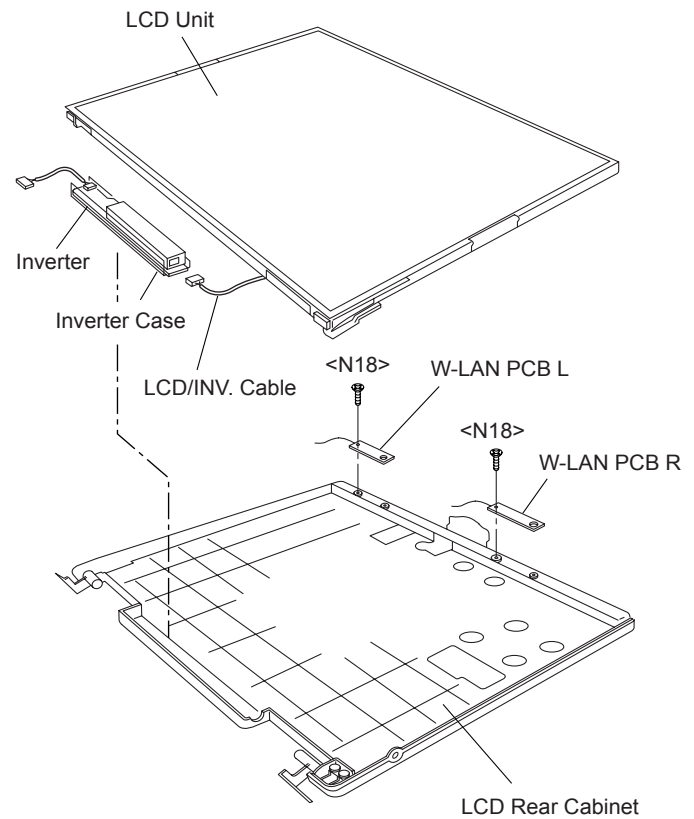

1. Disconnect the LCD/INV. Cable from the Connector on the Inverter.
2. Remove the LCD Unit.
3. Remove the Inverter with the Inverter Case.
4. Remove the two Screws <N18>, and then the W-LAN PCB L and R.

Screws <N18>: XQN17+BJ6FJ

9.1.18. Removing the Touch PAD and PAD PCB

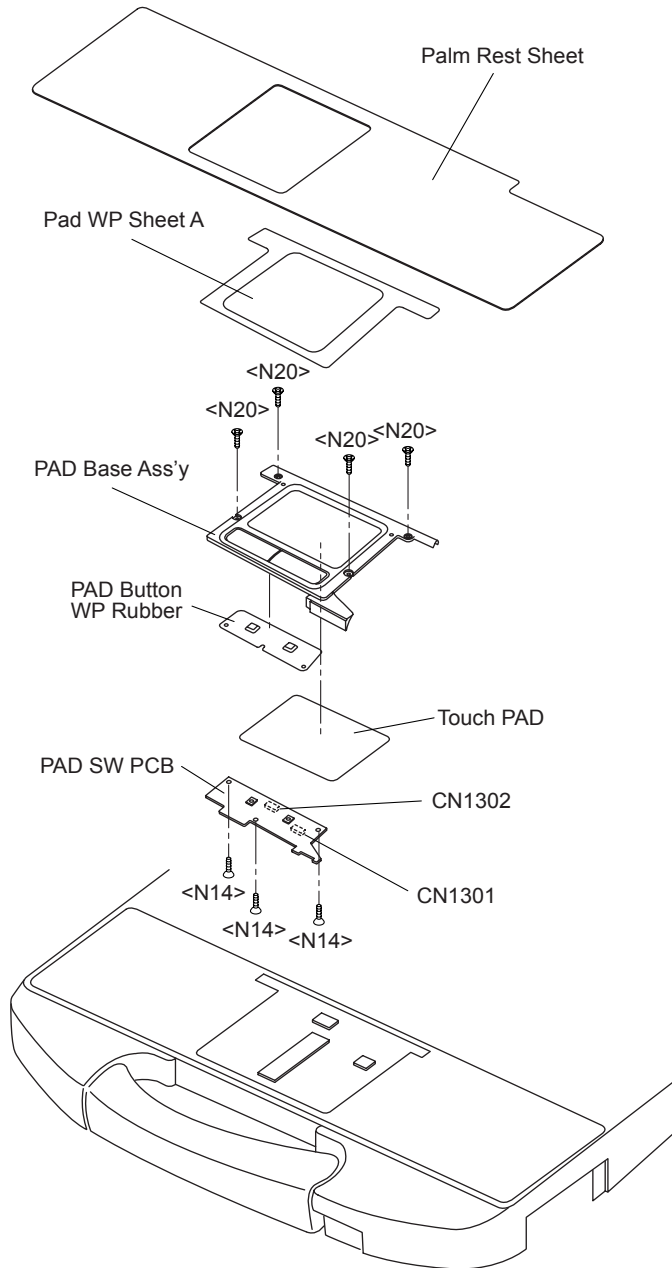

1. Remove the Palm Rest Sheet.
2. Remove the four Screws <N20>, and then PAD Base Ass'y.
3. Disconnect the two Cables from the two Connectors (CN1301, CN1302).
4. Remove the three Screws <N14>.
5. Remove the PAD Button WP Rubber and PAD SW PCB.
6. Remove the Touch PAD.

Screws <N14>: DRHM0106ZA

Screws <N20>: DXQT2+G4FCL

9.1.19. Removing the Finger PCB

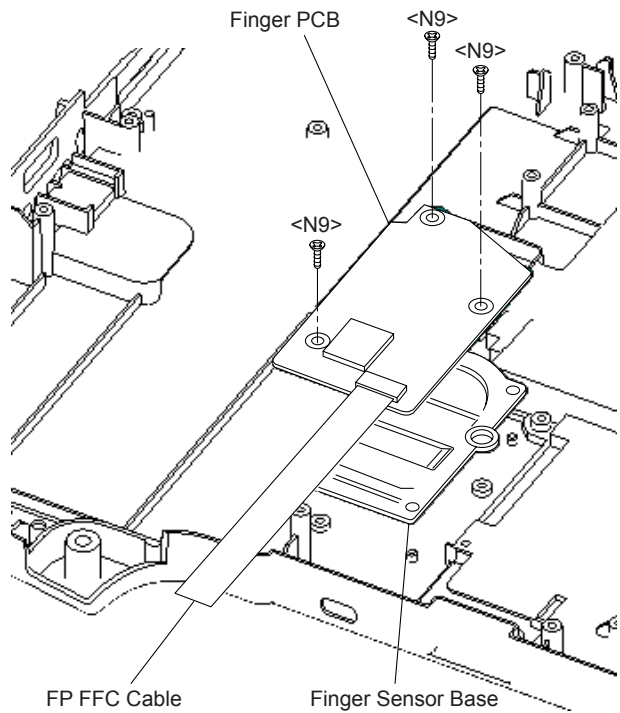

Preparation

Perform the steps up to removing of the Main PCB.

1. Remove the three Screws. <N9>
2. Remove the Finger PCB and Finger Sensor Base.

Screws <N9>: DFHE5025XA

9.2. Reassembly Instructions

9.2.1. Attention when CF-74 series is repaired

- Please execute writing BIOS ID when you exchange the Main Board.
- You cannot reuse the Conductive Clothes and the heat dissipating parts such as Sheet and Rubber. Use new parts.

9.2.2. Setting the Finger PCB

1. Fix the Finger PCB and the Finger Sensor Base to the computer using the 3 Screws <N9>.
2. Connect the FP FFC Cable to the Connector (CN27) on the Main PCB.

Screws <N9>: DFHE5025XA

■ Preparing and setting the Finger Sensor Base

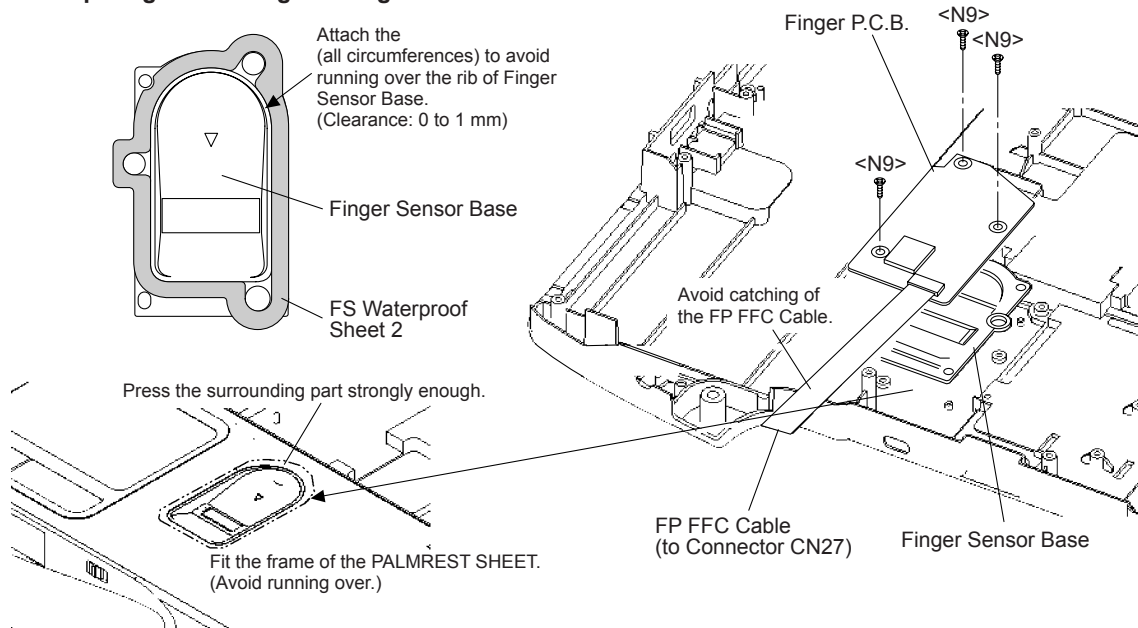

9.2.3. Setting the LCD Unit and the Inverter

1. Fix the W-LAN PCB L and R to the LCD Rear Cabinet using the two Screws <N18>.
2. Attach the Inverter with the Inverter Case to the LCD Rear Cabinet.
3. Set the LCD Unit to the LCD Rear Cabinet.
4. Connect the LCD/INV. Cable to the Connector on the Inverter.

Screws <N18>: XQN17+BJ6FJ

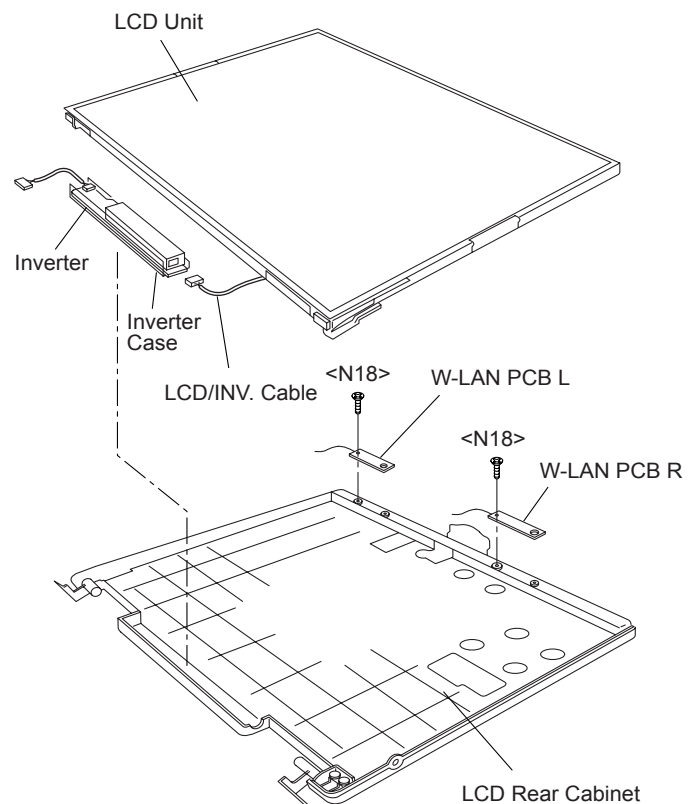

■ Arranging the W-LAN L and R Cable

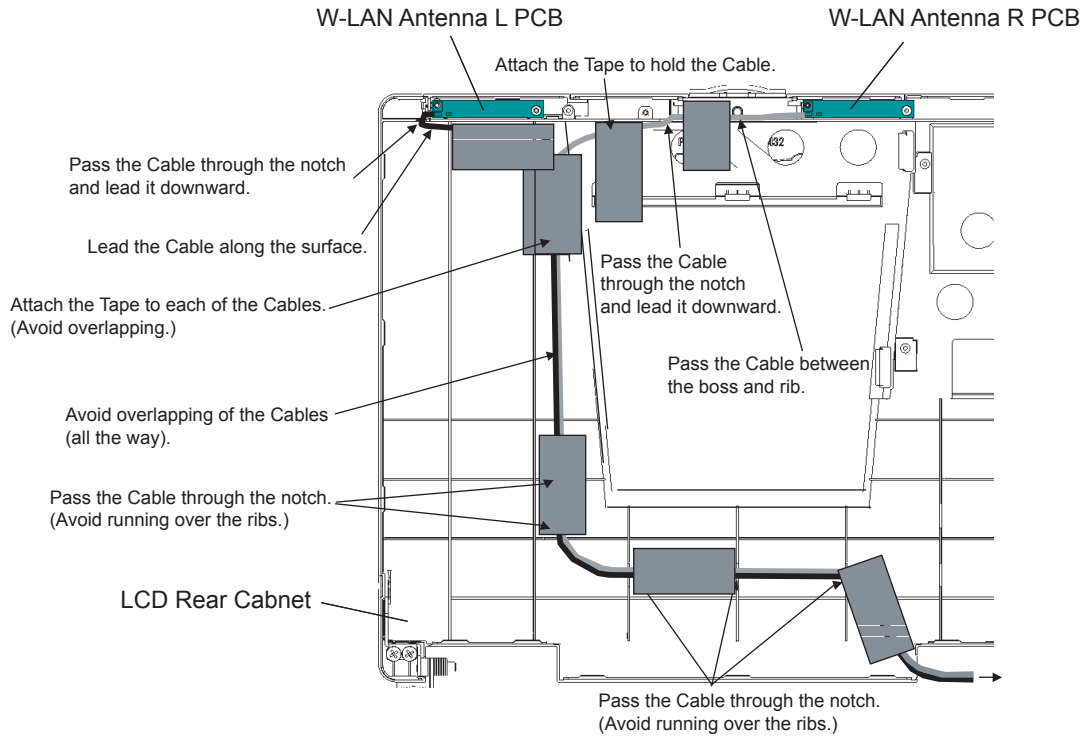

■ Attaching the LCD Damper C and LCD Damper D

1. Attach the four LCD Damper C to the upper part and lower part of the LCD Unit.
2. Attach the LCD Damper D to the upper center of the LCD Unit.

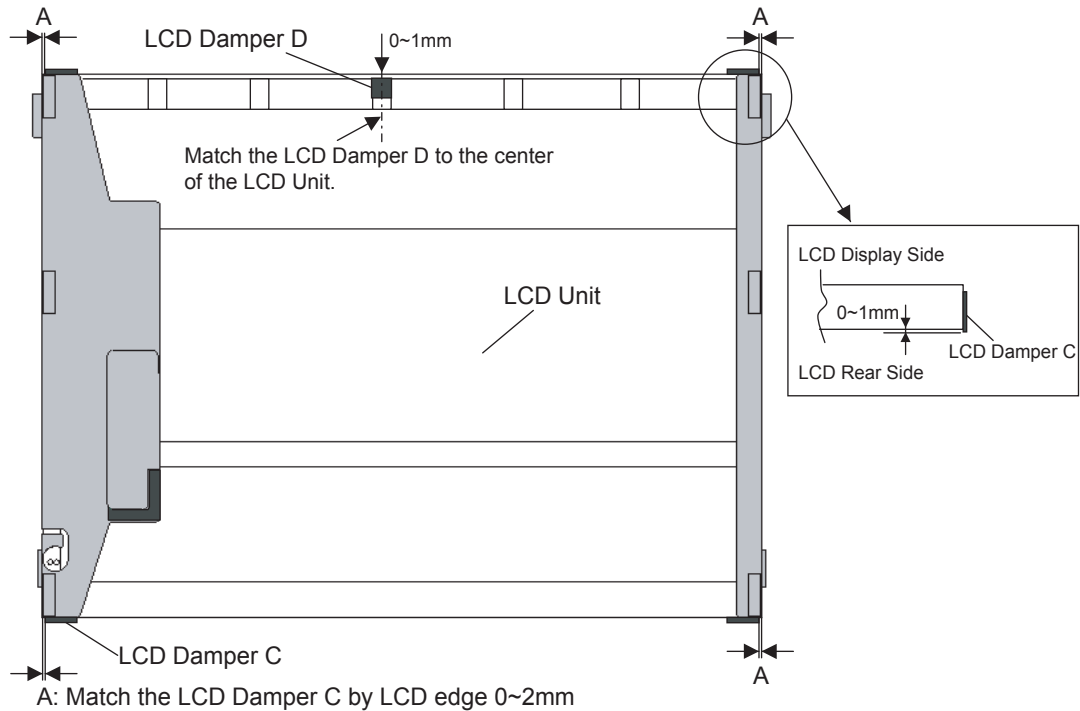

■ Arranging the LCD/TS Cable

1. Connect the LCD/TS Cable (LCD) to the Connector on the LCD Unit.
2. Connect the LCD/TS Cable (TS) to the Connector (CN603) on the TS PCB.

B: Attaching the Cloth

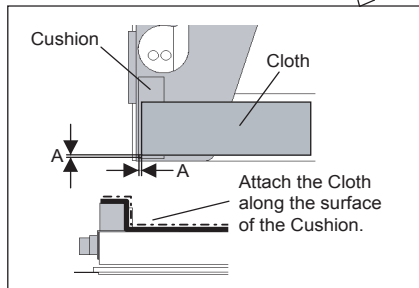
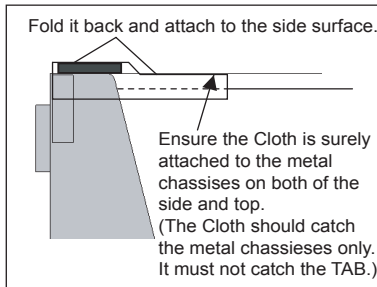
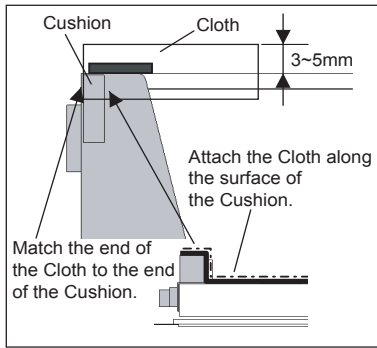

A: Match the Cloth by Cushion edge 0~1mm

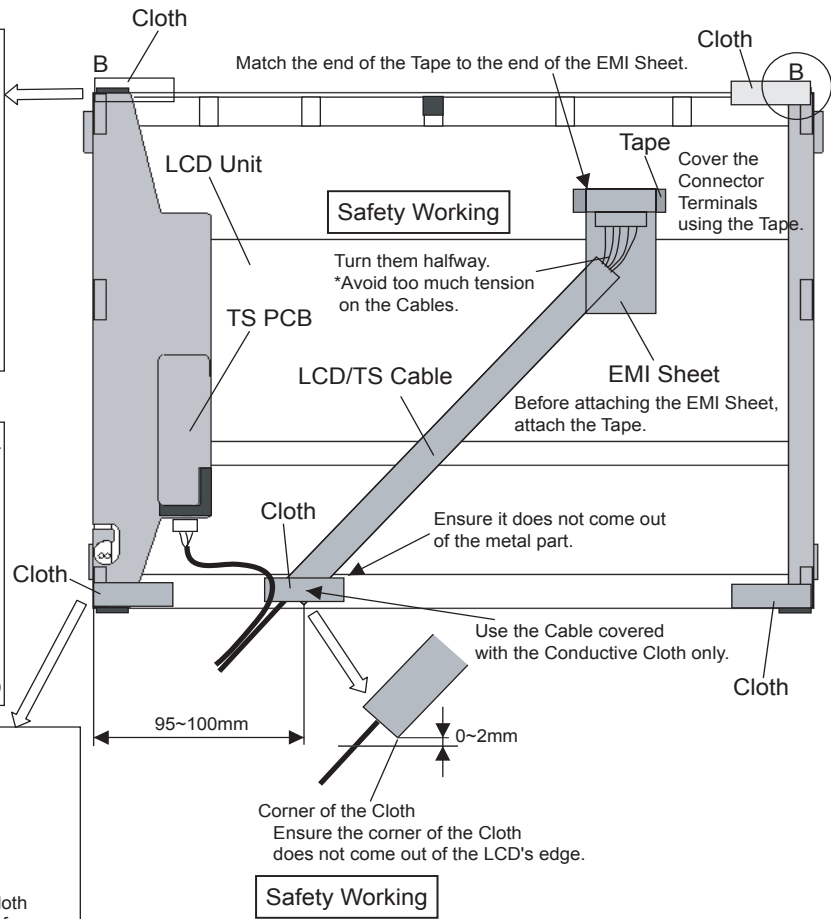

■ Arranging the TP Power Cable and Attaching the TP/LCD Sheet

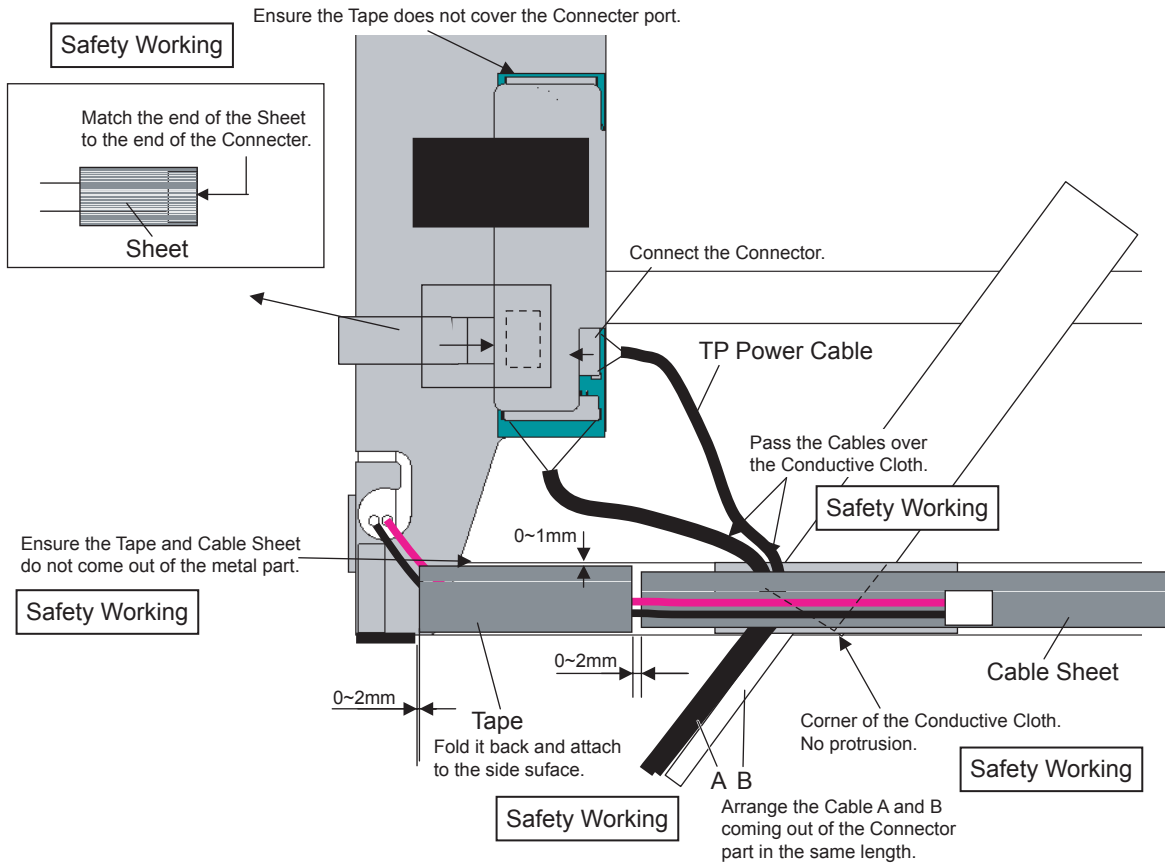

■ Setting the Inverter and Arranging the Inverter Cable

1. Insert the Inverter to the Inverter Case, and connect the Inverter Cable to the Connector on the Inverter.
2. Fix the Connector of the Inverter Cable using the Tape.

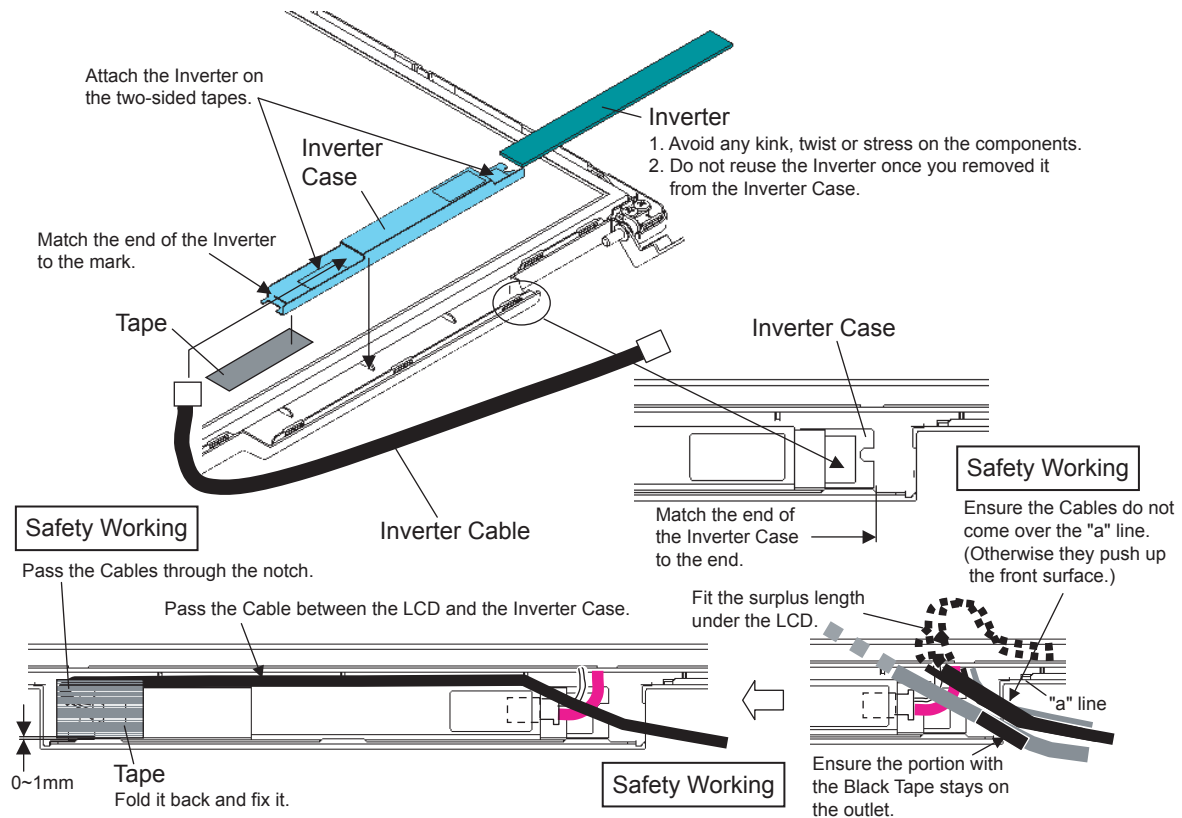

■ Cautions for Setting the LCD Unit

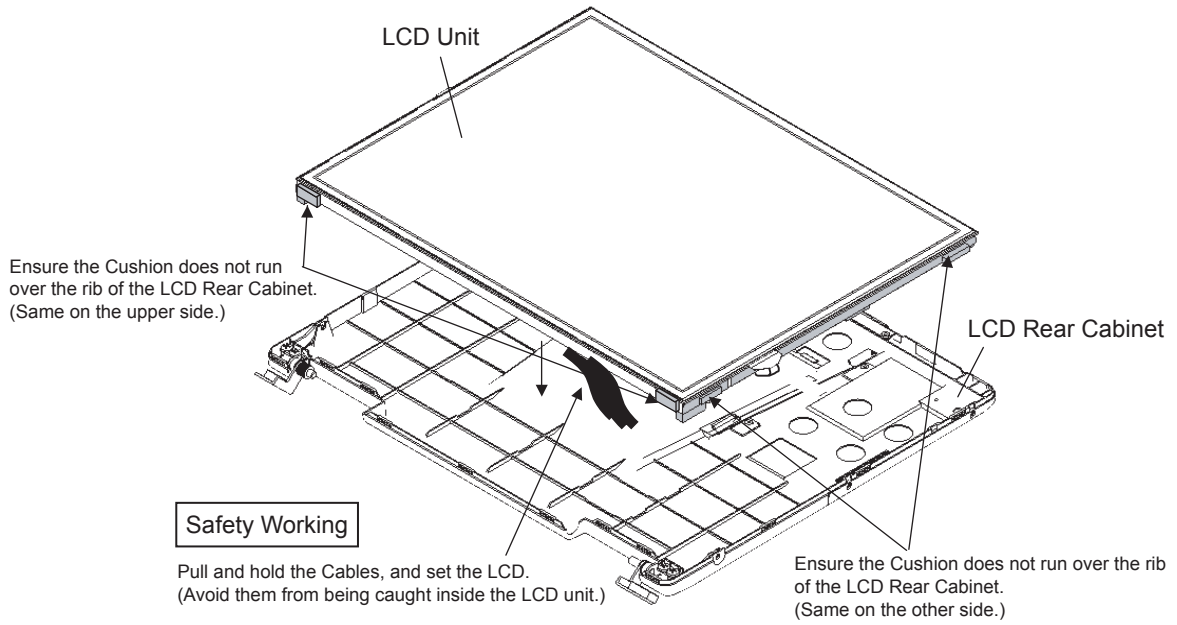

9.2.4. Setting the LCD Front Cabinet

1. Set the LCD Front Cabinet to the LCD Rear Cabinet.
2. Fix the LCD Front Cabinet using the two Screws<N15>.
3. Fix the LCD Front Cabinet using the two Screws<N16>, and attach the two LCD Leg Rubbers.

Screws <N15>: DRHM0075ZA

Screws <N16>: DXQT2+G4FCL

■ Fixing of the LCD Front Cabinet

Ensure all the 23 Hooks are securely set in.

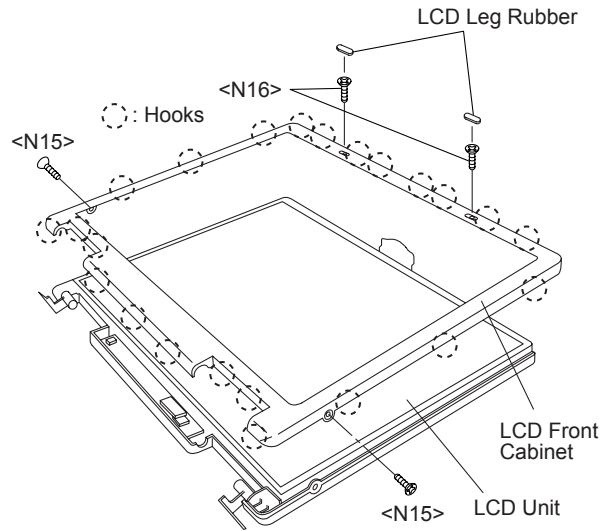

9.2.5. Setting the Display unit

1. Attach the Gasket.
2. Set the Hinge Screw Cover L and R to the Hinge L and R.
3. Pass the Cables coming out of the LCD Unit into the computer.
4. Fix the Display Unit using the two Screws<N6> from the computer upper side.
5. Fix the Display Unit using the four Screws<N6> from the computer bottom side.

Screws. <N6>: DXSB3+6FNL

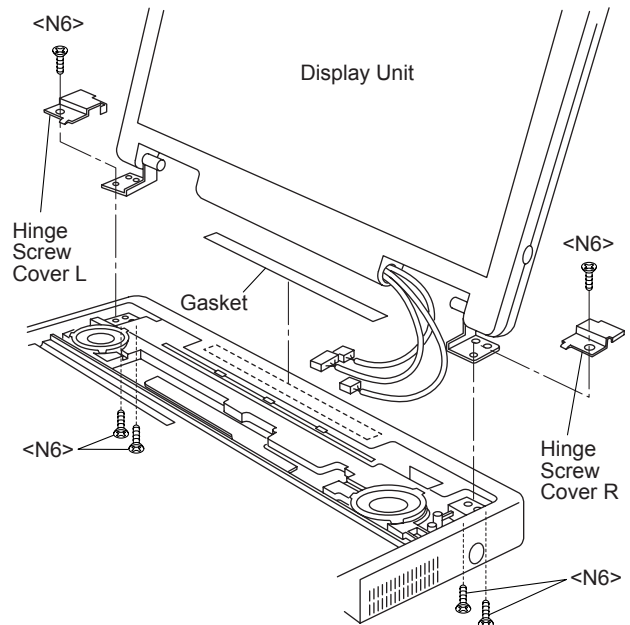

9.2.6. Setting the USB PCB

1. Fix the USB PCB to the computer using the two Screws <N9>.
2. Connect the USB Cable to the Connector (CN1701).

Screws <N9>: DFHE5025XA

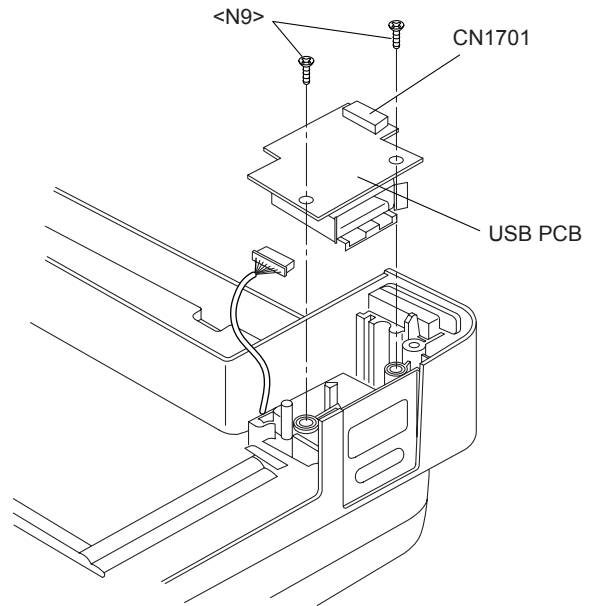

■ Arranging the USB Cable

Safety Working

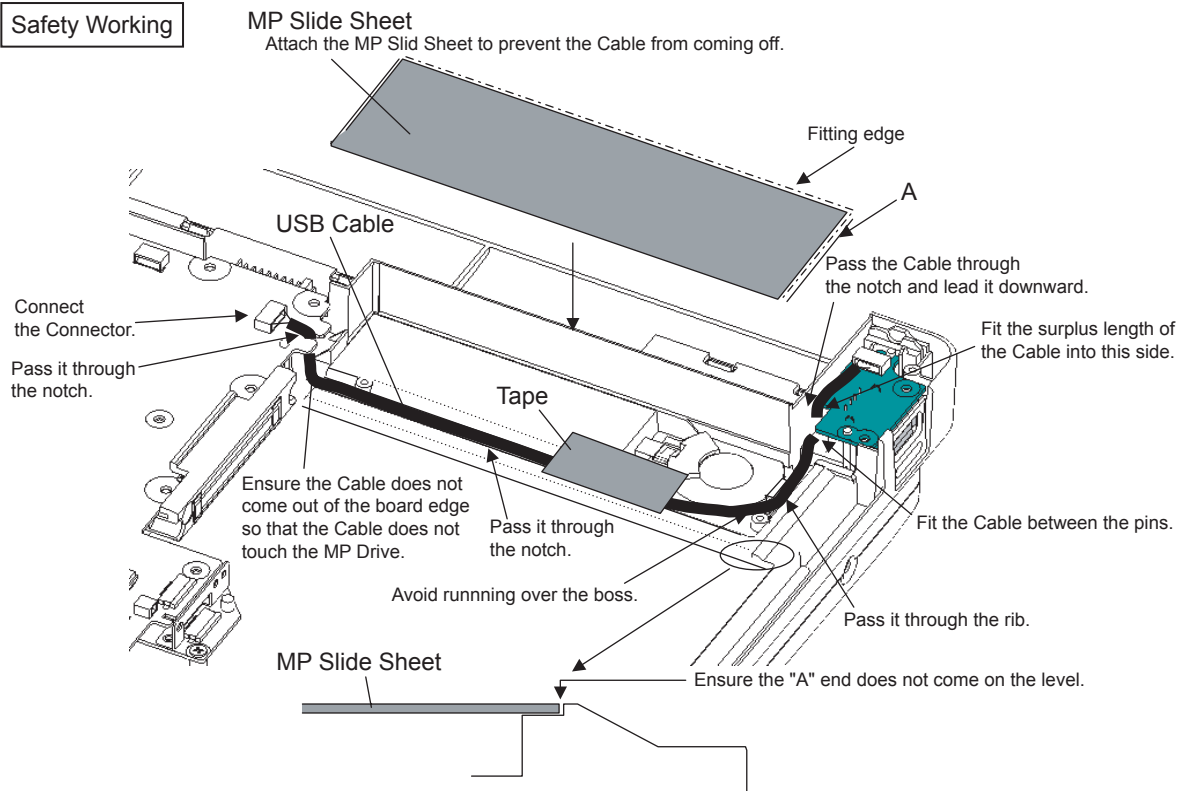

9.2.7. Setting the SD PCB, Heat Sink and FAN Motor

1. Connect the SD FFC to the Connector (CN1401).
2. Fix the SD PCB to the computer using the three Screws<N9>.
3. Set the Heat Sink, Fan Duct and the four Heat Sink Springs.
4. Fix the FAN Motor to the computer using the two Screws<N5>.
5. Attach the Fan Tape 1 and 2 on the FAN Motor, and fix the Cable Holder on them.

Screws <N5>: DXSB2+6FNL
Screws <N9>: DFHE5025XA

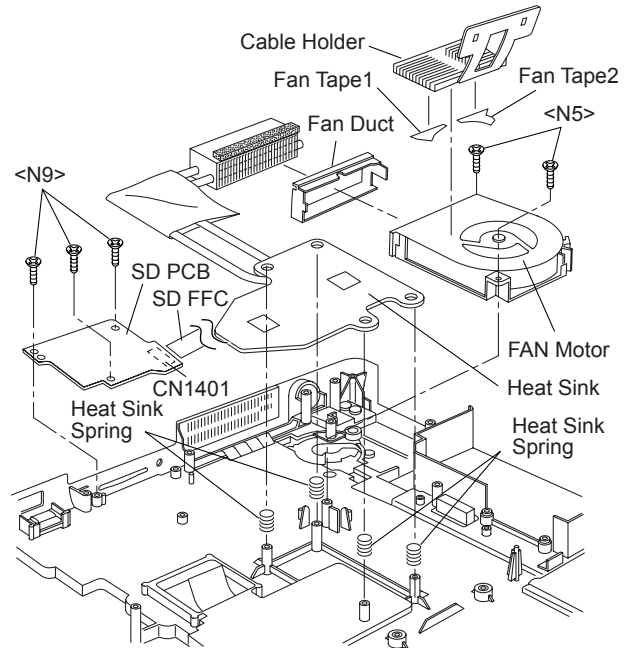

■ Applying Grease on the Heat Sink

1. Apply grease on two points of the Heat Sink.
2. Attach the Pipe Sheet on the Heat Pipe.

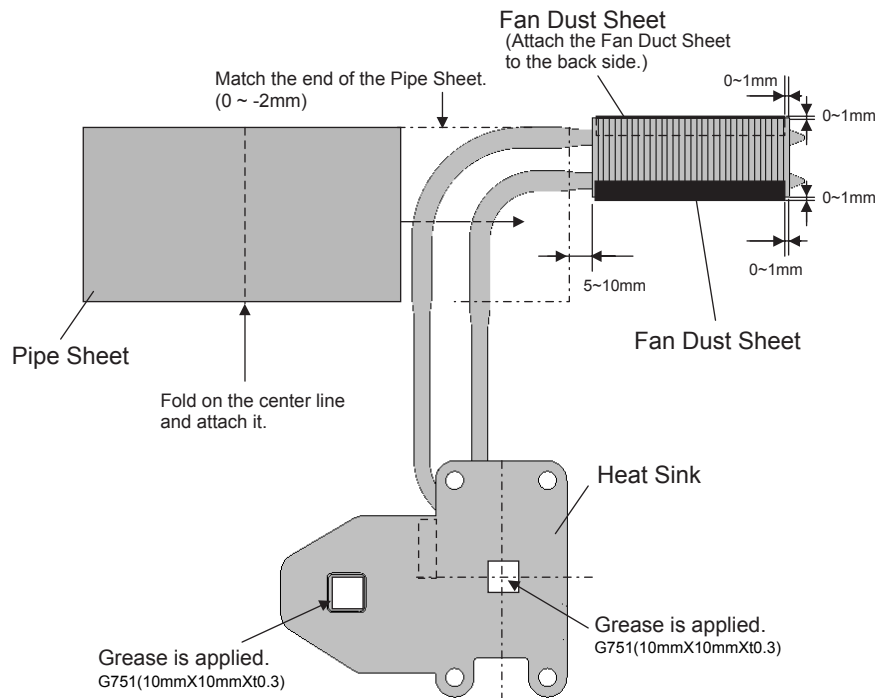

9.2.8. Setting the DC-IN PCB and I/O PCB

1. Fit the Modem Cable and LAN Cable between the MODELAN Holders, and set them on to the computer.
2. Fix the I/O PCB to the I/O Plate using the four Screws<N19>.
3. Fix the I/O PCB with I/O Plate to the computer using the two Screws<N9>.
4. Fix the DC-IN PCB to the computer using the two Screws<N9>.

Screws <N9>: DFHE5025XA

Screws <N19>: DFHE5035ZB

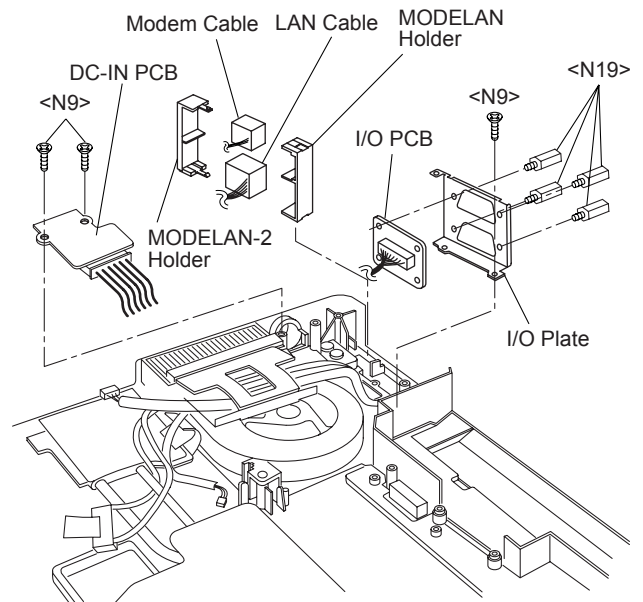

■ Arranging the DC-IN Cable

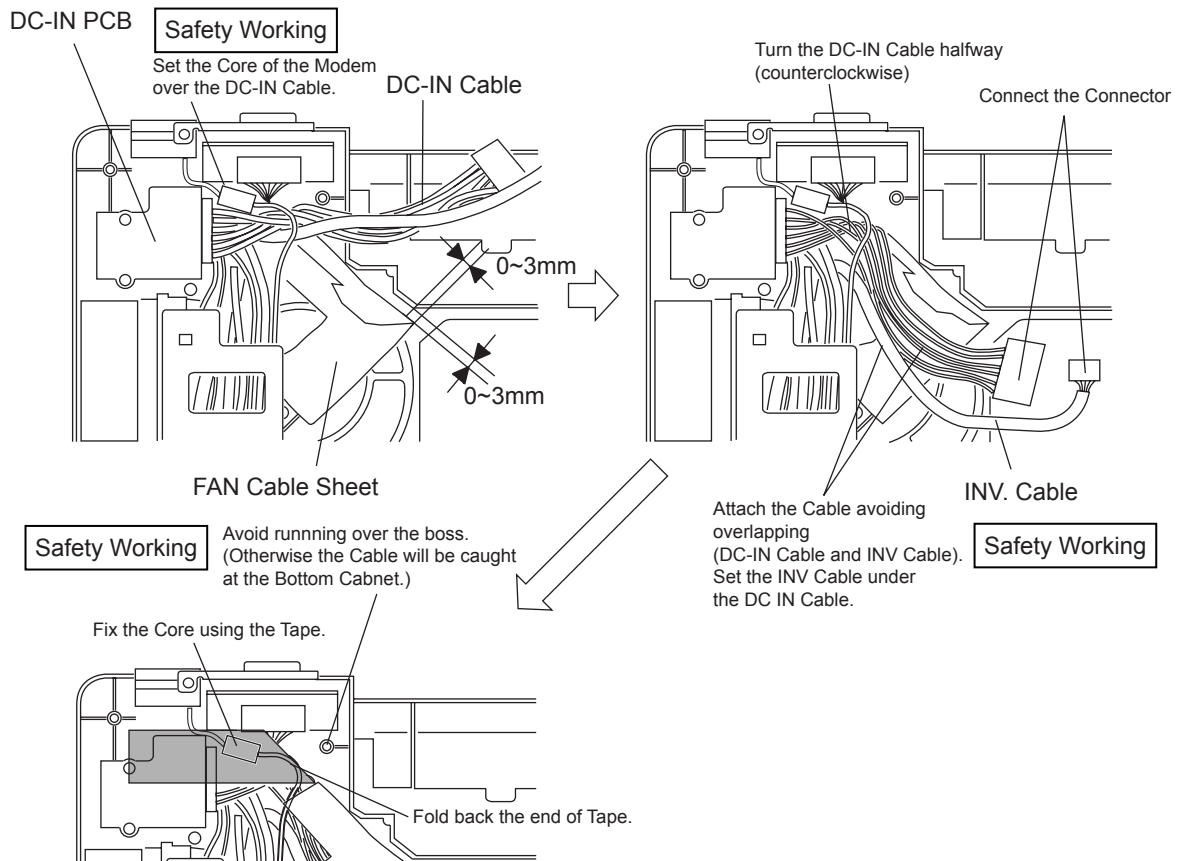

9.2.9. Setting the PC Card Ejector and Lithium Battery

1. Attach the Lithium Battery to the Main PCB.
2. Pass the Lead Wire of the Lithium Battery through the groove of the Main PCB, and connect it to the Connector (CN14) on the back side.
3. Fix the PC Card Ejector to the Main PCB using the two Screws<N9>.

Screws <N9>: DFHE5025XA

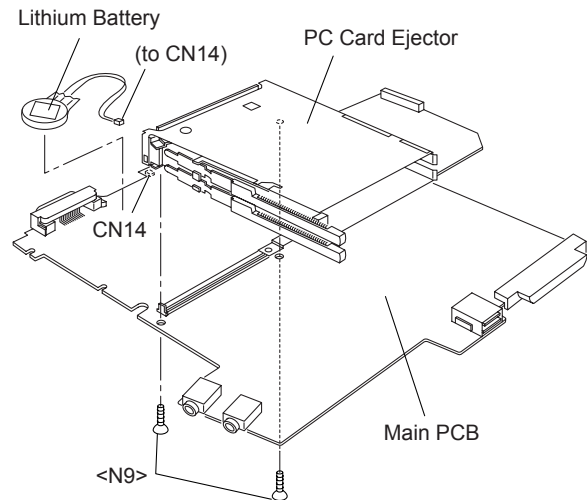

■ Arranging the Lithium Battery

Safety Working

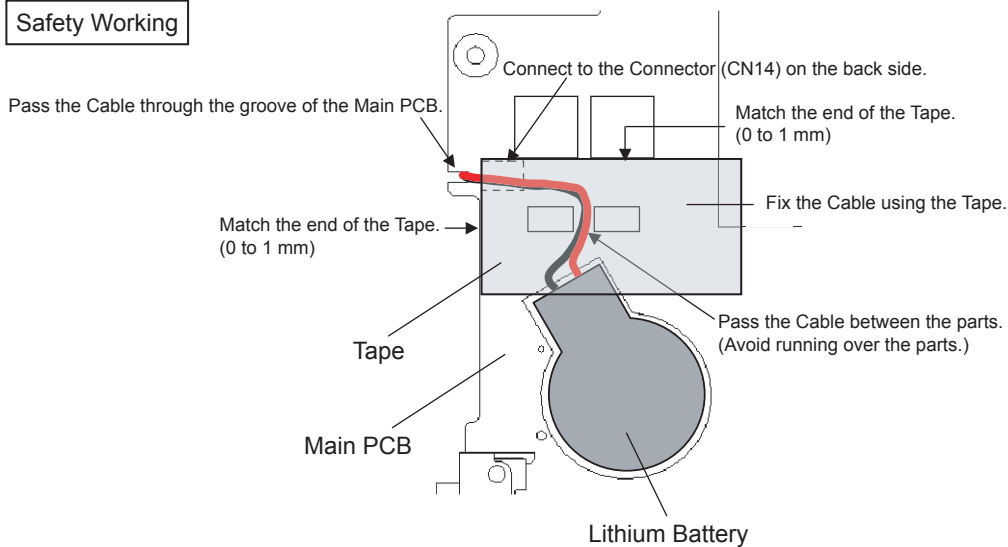

9.2.10. Setting the Main PCB

Note:

After replacing the Main Board, rewrite the BIOS ID.

1. Set the MP Guide to the Main PCB.
2. Set the Main PCB to the computer.
3. Fix the Main PCB using the six Screws<N9>.
4. Connect the ten Cables to the corresponding Connectors (CN6, CN7, CN24, CN19, CN28, CN21, CN802, CN18, CN15, CN25).

Screws <N9>: DFHE5025XA

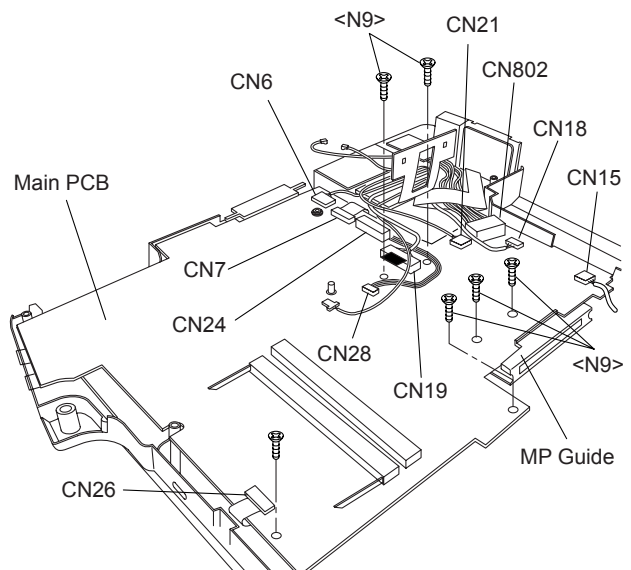

■ Arranging the Cables to the Cable Holder and their Wiring Order

- Pull the surplus length of the Cable coming from the LCD side to inside of the unit.
(If the surplus length comes outside, it will be caught by the center cover during setting.)
- Fit the Cables to the corresponding grooves of the Cable Holder.
- Ensure the Cables in the Cable Holder are wired in the correct order.

Safety Working

Be sure to wire the Cables in the correct order.

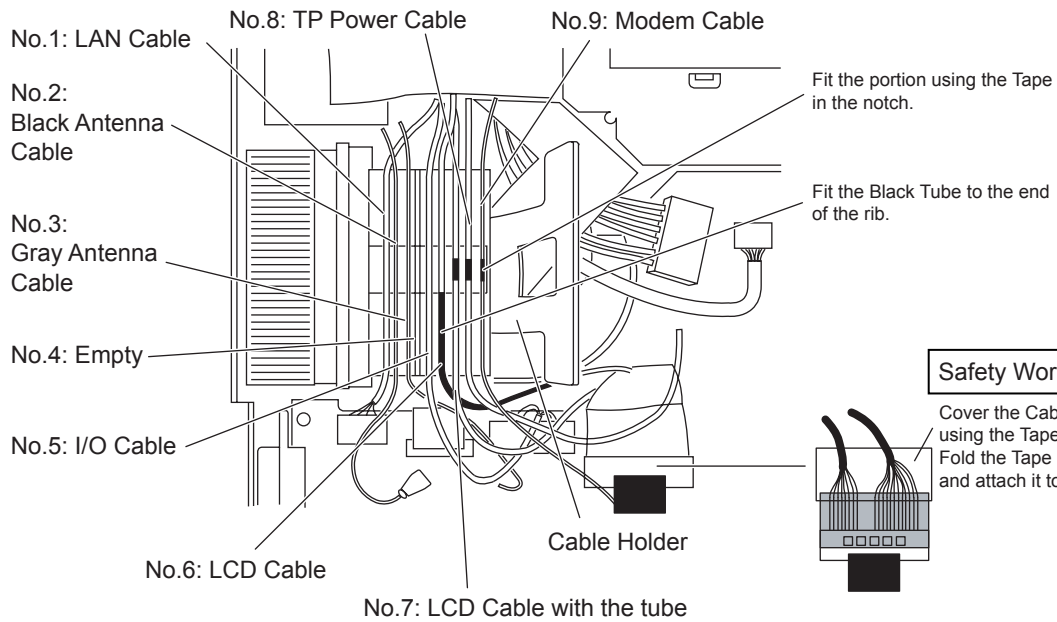

■ Arranging the FAN Cable

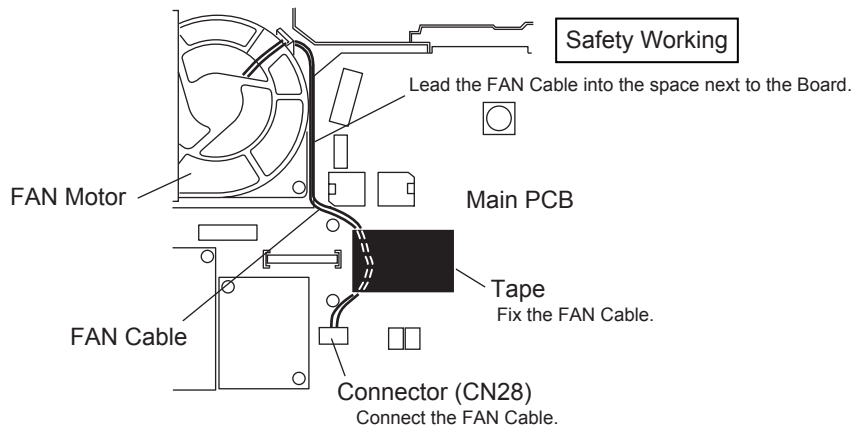

9.2.11. Setting the Wireless Module and MDC Module

1. Connect the Modem Cable to the Connector, and fix the MDC Module to the Main PCB using the two Screws<N9>.
2. Connect the Wireless Module to the Connector of the Main PCB, and fix it using the two Screws<N9>.
3. Connect the two Antenna Cables to the two Connectors on the Wireless Module.
 - Antenna Cable (Black): MAIN Connector
 - Antenna Cable (Gray): AUX Connector

Screws <N9>: DFHE5025XA

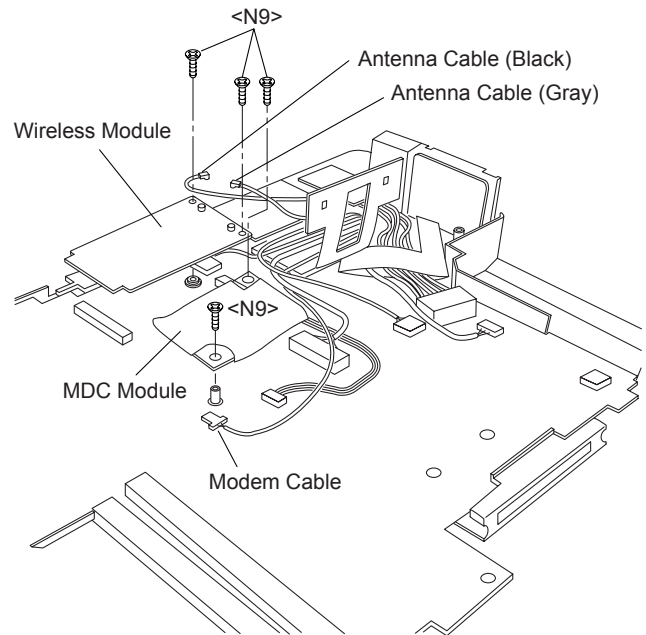

■ Arranging the Modem Cable

<Preparation for assembly of the MDC Module>

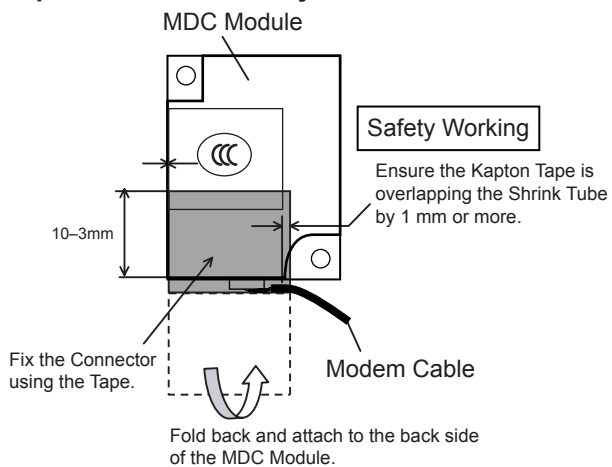

Arranging the Modem Cable

<Good example>

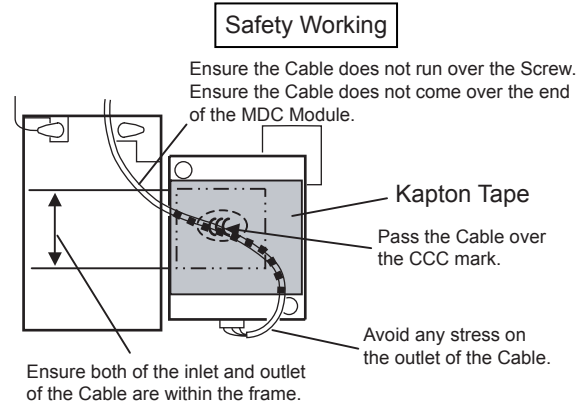

<Bad example>

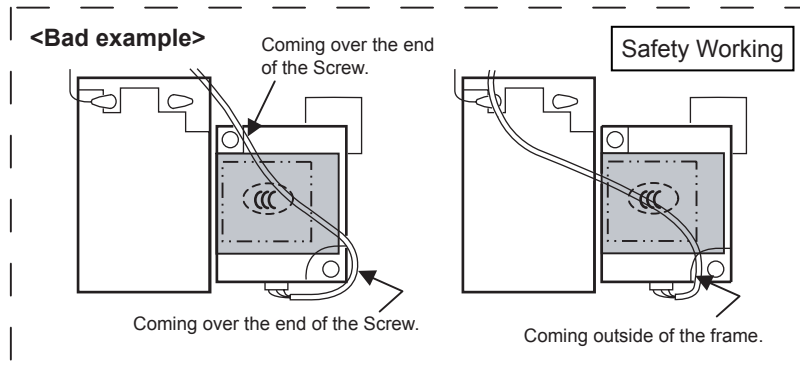

9.2.12. Setting the Bottom Case

1. Attach the Gasket and Sheet.
2. Set the Bottom Case.
3. Fix the Bottom Case using the ten Screws<N7>. No1 to No10
4. Fix the Bottom Case using the six Screws<N5>. No11 to No16
5. Fix the Bottom Case using the two Screws<N8>. No17, No18
6. Close the Lid Covers.

Note:

Tighten the Screws in the numbered order (No1 to No18).

Screws <N5>: DXSB2+6FNL

Screws <N7>: DXYN2+J16FNL

Screws <N8>: DXYN2+J8FNL

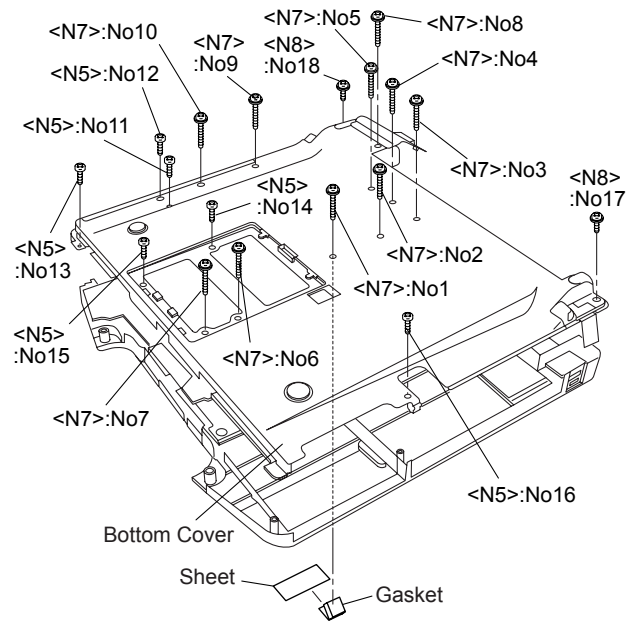

9.2.13. Setting the Handle Ass'y

1. Set the two Sleeves A, the Handle Ass'y and the two Sleeves B.
2. Fix the Handle Cover L and R using the two Screws<N2>. No1, No2
3. Fix the Handle Cover L and R using the three Screws<N4>. No3 to No5

Note:

Tighten the Screws in the numbered order (No1 to No5).

Screws <N2>: DRHM4+10FKS

Screws <N4>: DRSB2+6FKL

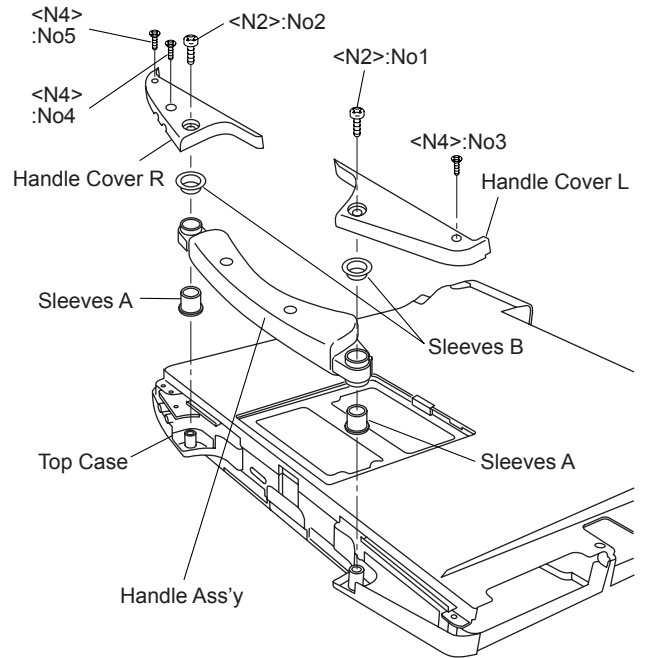

9.2.14. Setting the Speaker and the LED PCB

1. Fix the LED PCB using the two Screws<N9>.
2. Set the Speaker L and R to the computer.
3. Connect the Speaker Cable L and R to the two Connectors (CN1002, CN1003) on the LED PCB.
4. Fix the Speaker Cable L and R using the Tape.
5. Fix the Speaker L and R using the Speaker Holder.

Note:

Ensure the three Hooks of the Speaker Holder are securely set in the computer.

Screws <N9>: DFHE5025XA

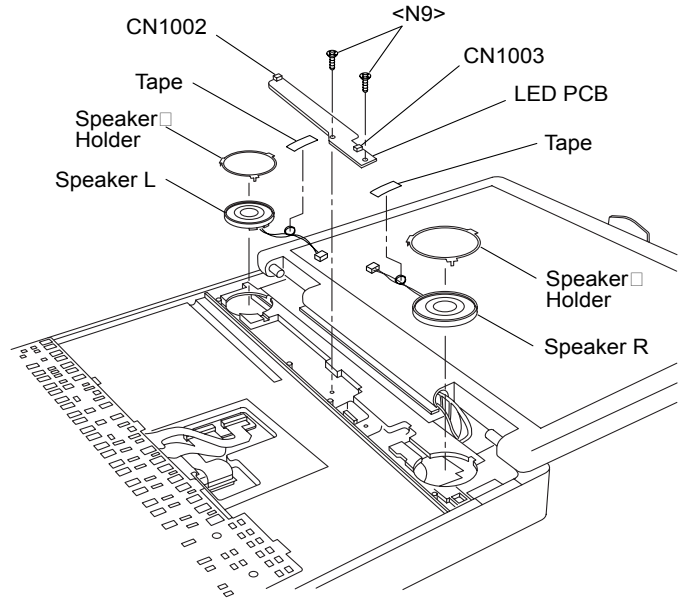

■ Soldering the Speaker Cable and Setting the Speaker Rubber

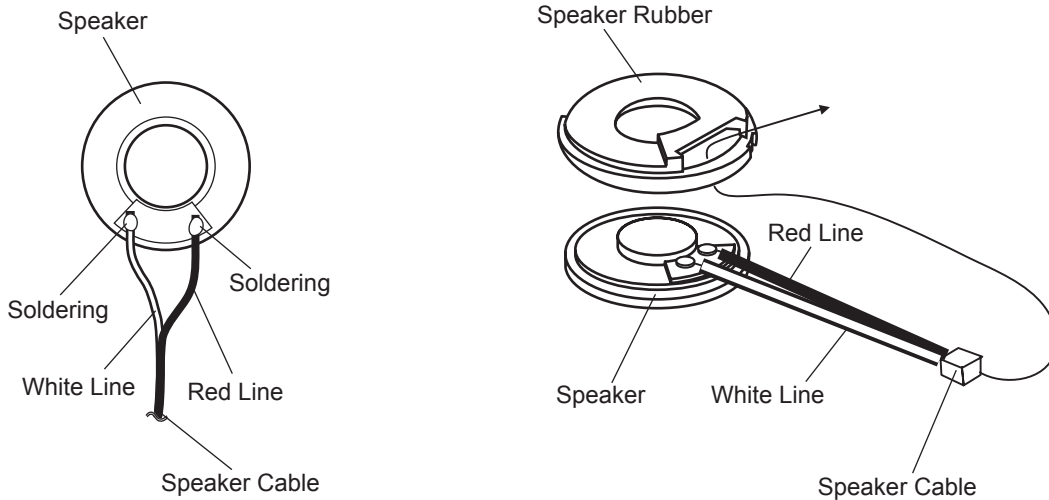

■ Cautions for Setting the Speaker

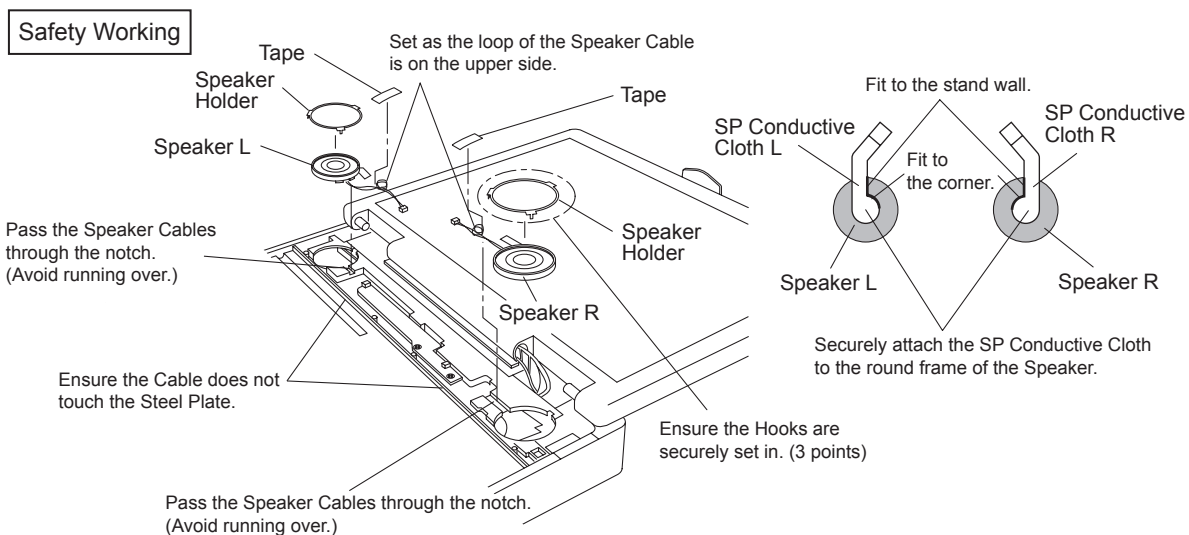

9.2.15. Setting the Keyboard

1. Connect the KBD FPC Cable to the Connector (CN25) of the Main PCB.
2. Connect the two Cables of the Keyboard to the two Connectors on the KBD FPC.
3. Remove the Release Paper of the KBD WP Sheet, and attach the KBD WP Sheet to the computer as it covers the Cable of the Keyboard.

Note:

Press strongly enough until the color of the contact of two-sided tape is changed.

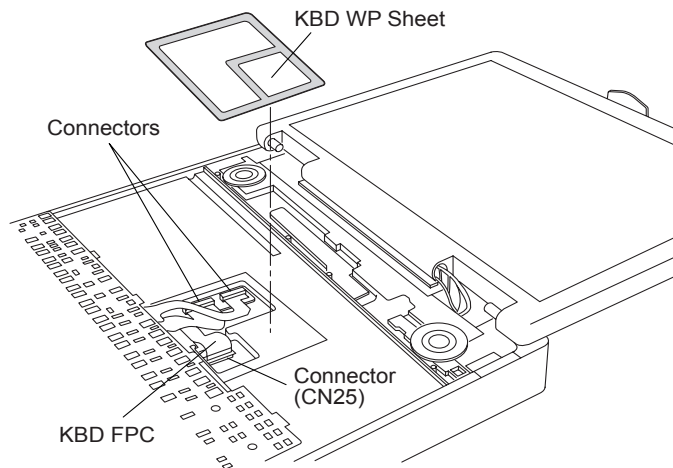

4. Insert the front Hooks of the Keyboard and the FPC to the computer, and set the Keyboard to the computer.
5. Fix the KBD Angle L and R using the four Screws <N9>.
6. Hook the six front Hooks of the Center Cover to the KBD Angle L and R.
7. Hook the seven rear Hooks of the Center Cover to the computer, and press the Center Cover to be securely set in.

Screws <N9>: DFHE5025XA

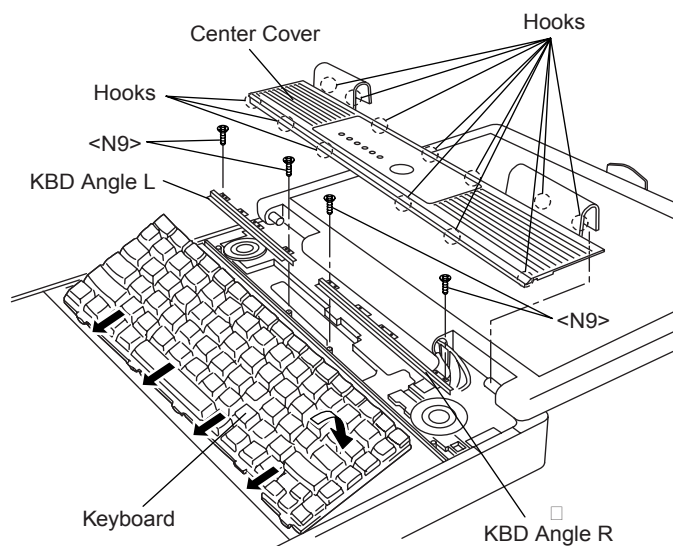

■ Cautions for Setting the Center Cover

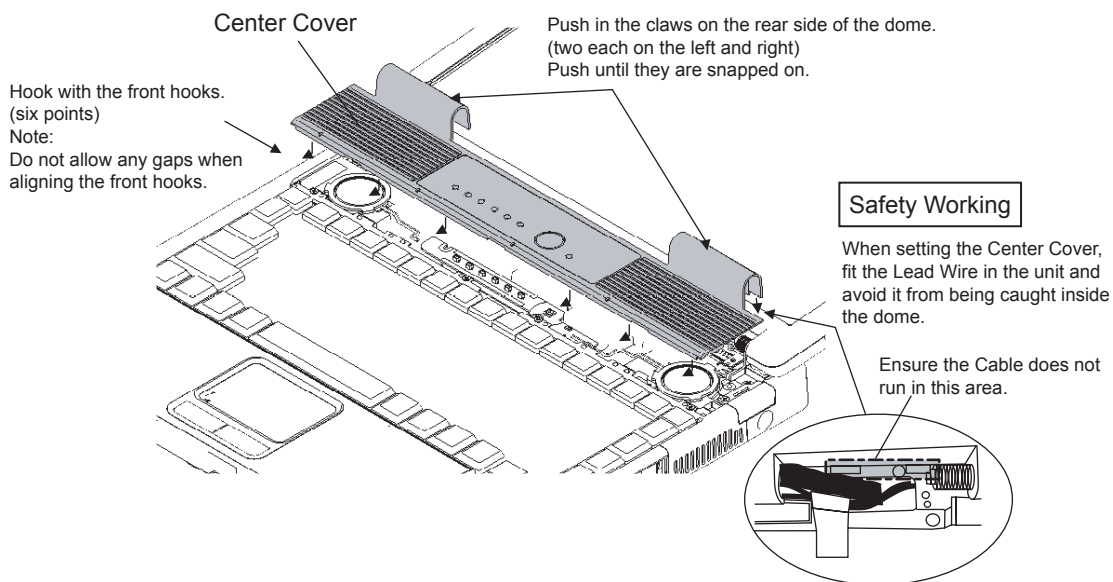

9.2.16. Setting the DIMM Memory Card and DIMM Cover

1. Set the DIMM Memory Card to the Main PCB.
2. Fix the DIMM Cover using the two Screws<N1>.

Screws <N1>: XSB2+3FNL

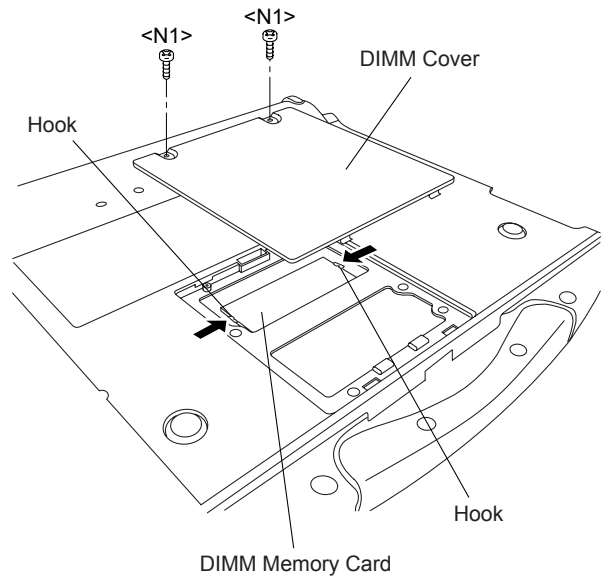

9.2.17. Setting the HDD

1. Attach the HDD Earth Plate and HDD Conductive Sheet.
2. Connect the HDD to the HDD FPC.
3. Attach the HDD Damper.
4. Fix the six Hooks, and attach the HDD Case.

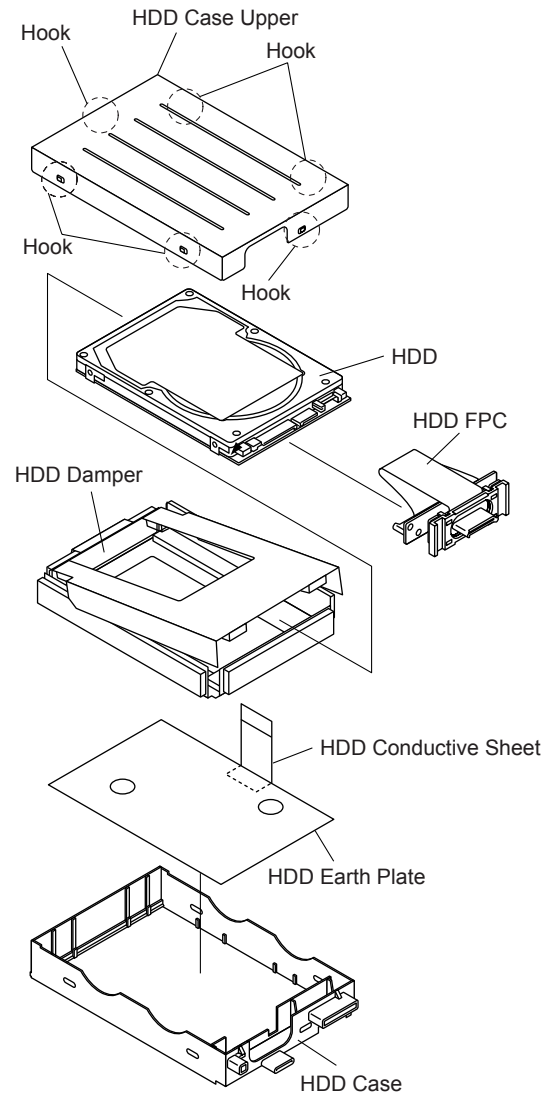

9.2.18. Setting the Battery Pack, the HDD Unit and the DVD-ROM Drive Unit

1. Set the DVD-ROM Driver Unit.
2. Set the HDD Pack.
3. Set the Battery Pack.
4. Slide the Latch 1 to the locked position.

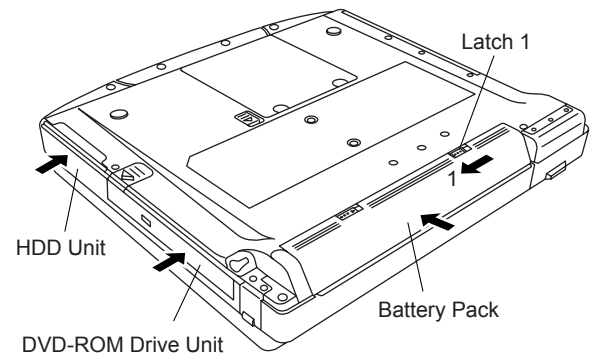

10 Exploded View

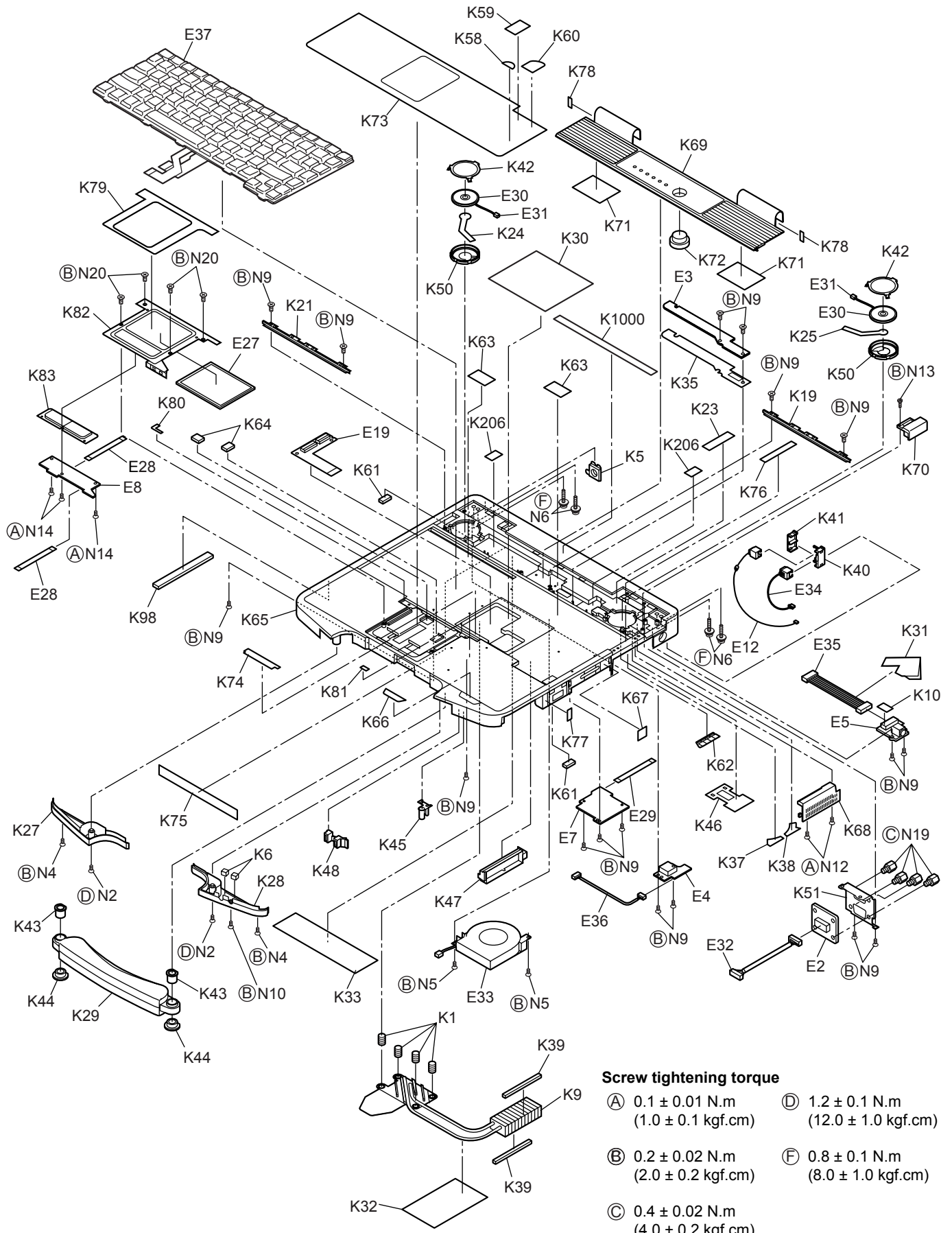

- Screw tightening torque**
- | | |
|--|--|
| Ⓐ 0.1 ± 0.01 N.m (1.0 ± 0.1 kgf.cm) | Ⓓ 1.2 ± 0.1 N.m (12.0 ± 1.0 kgf.cm) |
| Ⓑ 0.2 ± 0.02 N.m (2.0 ± 0.2 kgf.cm) | Ⓕ 0.8 ± 0.1 N.m (8.0 ± 1.0 kgf.cm) |
| Ⓒ 0.4 ± 0.02 N.m (4.0 ± 0.2 kgf.cm) | |

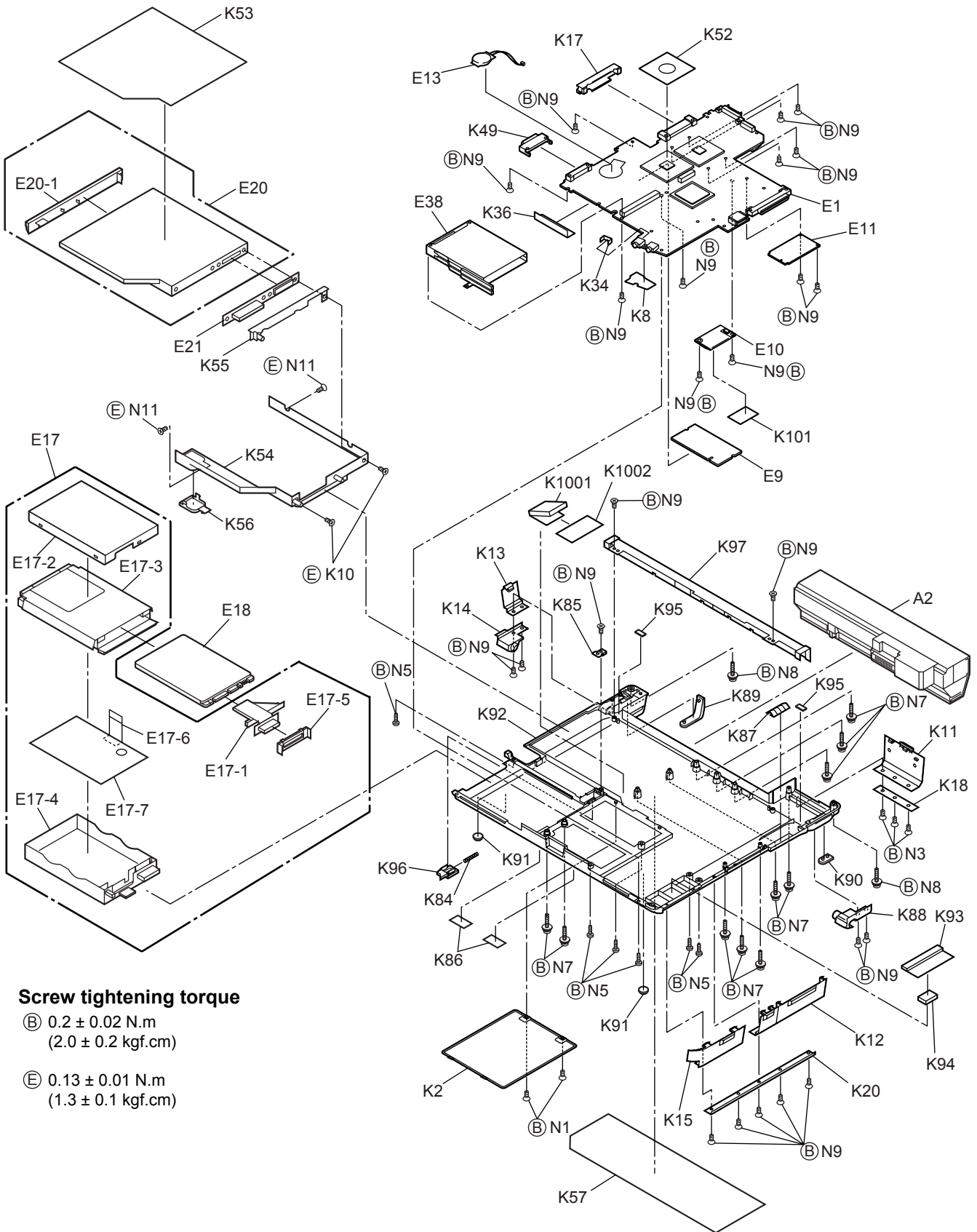

Screw tightening torque

- Ⓑ 0.2 ± 0.02 N.m
(2.0 ± 0.2 kgf.cm)
- Ⓔ 0.13 ± 0.01 N.m
(1.3 ± 0.1 kgf.cm)

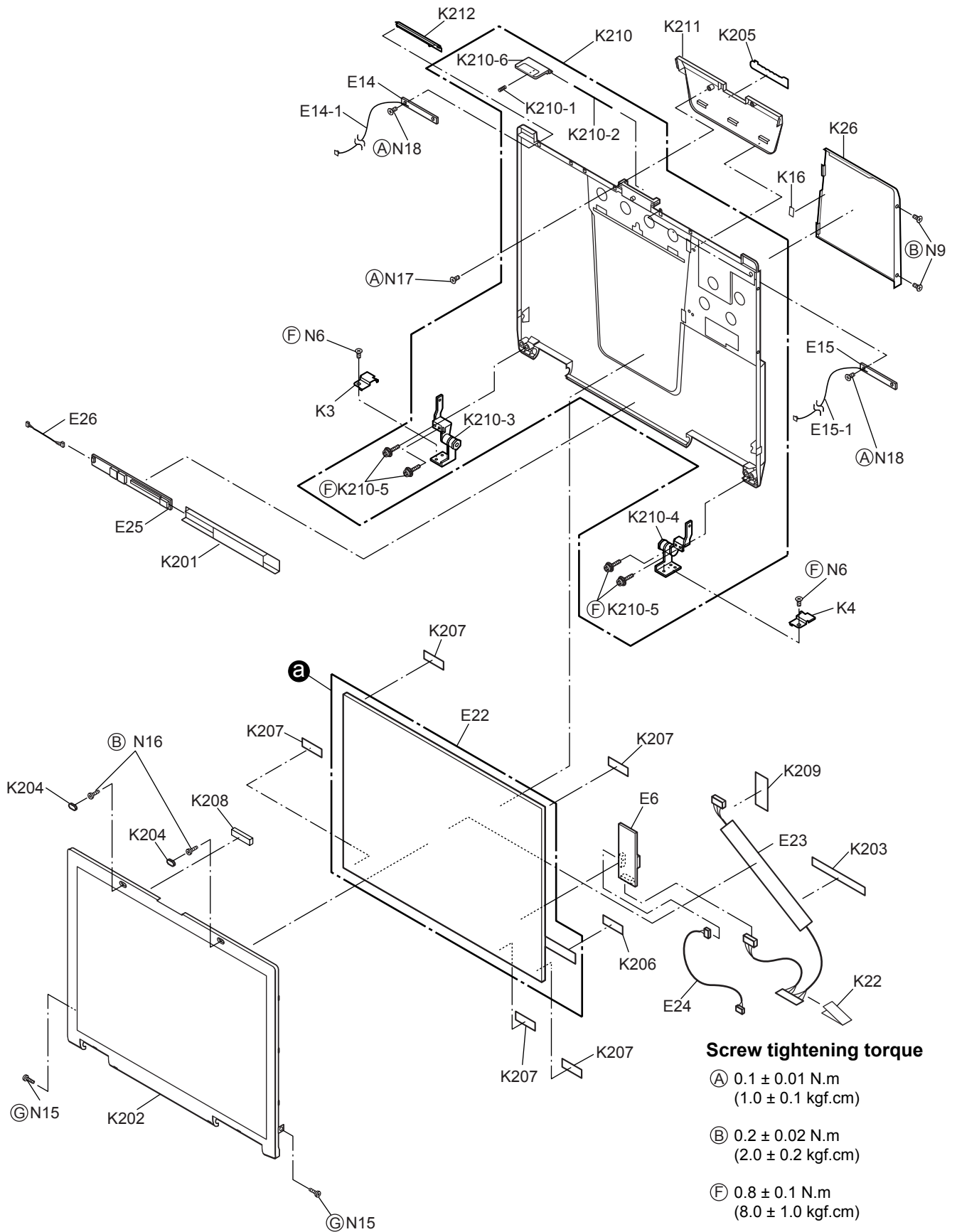

Screw tightening torque

- Ⓐ 0.1 ± 0.01 N.m
(1.0 ± 0.1 kgf.cm)
- Ⓑ 0.2 ± 0.02 N.m
(2.0 ± 0.2 kgf.cm)
- Ⓕ 0.8 ± 0.1 N.m
(8.0 ± 1.0 kgf.cm)
- Ⓖ 0.375 ± 0.025 N.m
(3.75 ± 0.25 kgf.cm)

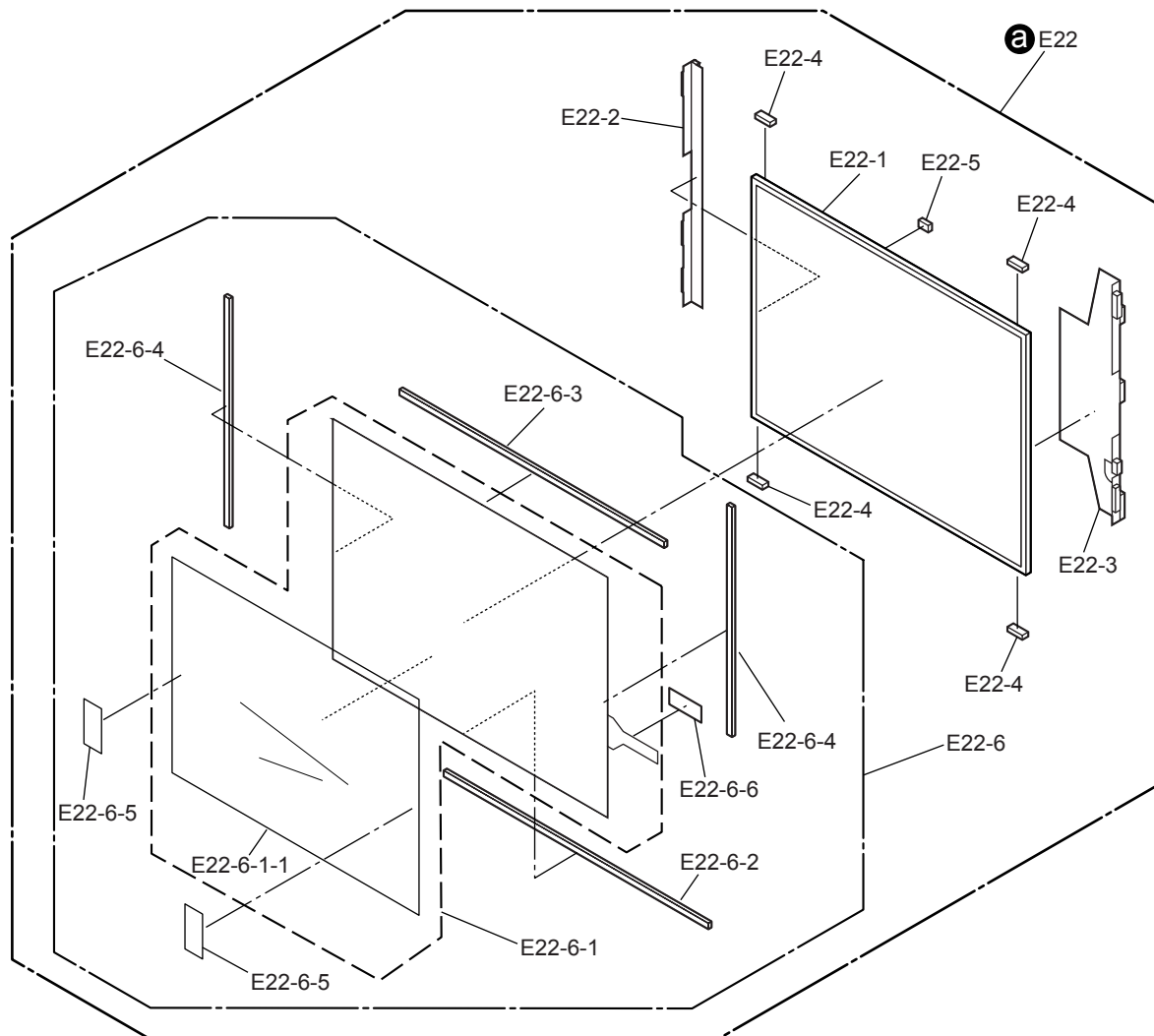

11 Replacement Parts List Comparison Table

Note : Important Safety Notice

Components identified by  mark have special characteristics important for safety.
When replacing any of these components, use only manufacturer's specified parts.

CF-74ECBAXBM

| REF. NO and AREA | PART NO. | | DESCRIPTION | Q'TY |
|-------------------------|--|--------------|------------------------|-------|
| | CF-74CCBAXBM | CF-74ECBAXBM | | |
| Main Block Unit | | | | |
| E1 | DL3U11518AAA | DL3U11518ABA | PCB, MAIN | RTL 1 |
| E2 | DL3U21518AAA | DL3U21518ABA | PCB, IO | RTL 1 |
| E3 | DL3U31518AAA | DL3U31518ABA | PCB, LED | RTL 1 |
| E4 | DL3U41518AAA | DL3U41518ABA | PCB, USB | RTL 1 |
| E5 | DL3U51518AAA | DL3U51518ABA | PCB, DC-IN | RTL 1 |
| E6 | DL3U61518AAA | DL3U61518ABA | PCB, TS | RTL 1 |
| E17 | DFWV99A0107 | DFWV99A0115 | HDD MOUNTING KIT | 1 |
| E17-6 | ----- | DFHE1027ZA | HDD CONDUCTIVE SHEET B | 0->1 |
| E17-7 | ----- | DFMC0872ZA | HDD EARTH PLATE | 0->1 |
| E22-6-1 | DL3DV0179AAA | DL3DV0179BAA | TS PREPARATION UNIT | 1 |
| Mechanical Parts | | | | |
| K18 | DFHM0386ZA-0 | DFHM0386ZB-0 | IO COVER PLATE | 1 |
| K20 | DFHM0390ZA-0 | DFHM0390ZB-0 | PC COVER PLATE | 1 |
| K99 | DFHG1599ZA | ----- | LCD DUMPER A | 1->0 |
| K100 | DFHR3D53ZB | ----- | SLIDE SHEET | 1->0 |
| K206 | DFMX0778ZA | DFMX0778ZA | SHEET | 4 |
| K1000 | ----- | DFHE1024ZA | GASKET-81TS10-2.5-145 | 0->1 |
| K1001 | ----- | DFHE1026ZA | GASKET-81TL15-14-10 | 0->1 |
| K1002 | ----- | DFHR7518ZA | SHEET | 0->1 |
| Accessories | | | | |
| A1 |  CF-AA1683AM1 | CF-AA1683AM3 | AC ADAPTOR | 1 |
| A3 |  DFQX5582YA | DFQX5582XA | MANUAL | 1 |
| | | | | |

Free Manuals Download Website

<http://myh66.com>

<http://usermanuals.us>

<http://www.somanuals.com>

<http://www.4manuals.cc>

<http://www.manual-lib.com>

<http://www.404manual.com>

<http://www.luxmanual.com>

<http://aubethermostatmanual.com>

Golf course search by state

<http://golfingnear.com>

Email search by domain

<http://emailbydomain.com>

Auto manuals search

<http://auto.somanuals.com>

TV manuals search

<http://tv.somanuals.com>