

Model: RSW2700, RSW2400, RSW2200

TABLE OF CONTENTS

	Page
Installation	1
General Features	2
Operating the Controls	3
Adjusting the Interior	3-5
Special Storage Areas	5-6
Food Storage Tips	6-8
Ice and Water Service	9-10
Non-Use Periods	10
Care and Cleaning	11-12
To Avoid Unnecessary Service Calls.....	13

IMPORTANT PERSONAL SAFETY INSTRUCTIONS

1. To prevent possibility of hazard due to electrical shock, never plug the refrigerator into a receptacle which has not been grounded adequately and in accordance with the local and national electrical codes. See the grounding instructions on page 1.
2. Unplug the refrigerator before cleaning the condenser or replacing a light bulb.
3. In case of power failure, minimize door openings. If the power failure is of a long duration, protect the food by placing blocks of dry ice on top of the packages or check with a local frozen foods locker plant about temporary storage. Frozen foods which have thawed completely should not be refrozen.
4. Any electrical service cord that becomes frayed or damaged should be immediately repaired or replaced. Never unplug your appliance by pulling on the power cord.
5. Your refrigerator should not be operated in the presence of explosive fumes.
6. Remove the doors from any out-of-use refrigerator to prevent child entrapment and suffocation.
7. Children should not climb, hang or stand on the shelves of this refrigerator.

ABOUT YOUR MAYTAG

Congratulations on your choice of a Maytag refrigerator! We know you will appreciate the many features that provide excellent performance, ease of cleaning, convenience and dependability. By following the instructions carefully, you will be able to fully enjoy and properly maintain your refrigerator.

Should you have any questions about using your Maytag refrigerator contact us. Be sure to provide the model and serial numbers of your refrigerator.

MAYTAG CONSUMER EDUCATION
 ONE DEPENDABILITY SQUARE
 NEWTON, IOWA 50208
 (515) 791-8911
 (Mon.-Fri., 8 am-5 pm Central Time)
 Internet: <http://www.maytag.com>

NOTE: For service information see page 13.

IMPORTANT: Keep your sales slip or cancelled check for warranty service. Proof of original purchase date is needed.

FOR FUTURE REFERENCE

For future reference we suggest you retain this manual after recording the model number, serial number (six numbers and two letters) and revision number of this refrigerator in the spaces provided below.

This information can be found on the data sticker located at the top front interior of the refrigerator compartment. (See example below.)

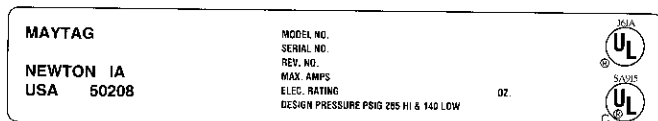

Model Number	Serial Number	Revision Number
--------------	---------------	-----------------

NOTE: In our continuing effort to improve the quality of our refrigerators, it may be necessary to make changes to the appearance without revising this manual.

INSTALLATION

Remove and discard the cantilever shelf packing clips located just above each shelf where it hooks onto the frame. To remove the plastic clips, wiggle the clips sideways and pull straight out.

Locating Your Refrigerator

1. Allow a free flow of air through the front base grille.
2. Your model should not be installed where the room temperature will go below 55° F., because it will not run frequently enough to maintain proper temperature in the freezer.
3. For ease of installation, you should leave a space of about 1/2 inch between the refrigerator and adjacent walls or cabinets. If the refrigerator is placed with the hinge side against a wall, you may want to leave additional space so the door can be opened wider. (Refer to the installation instructions for more detail.)

Important Leveling Information

Your refrigerator is equipped with front and back rollers so it can be moved away from the wall for cleaning. The front rollers are adjustable and should be positioned so the refrigerator sits firmly on the floor and is level.

To adjust the front rollers:

1. Remove the base grille by grasping the ends, lift and pull out.

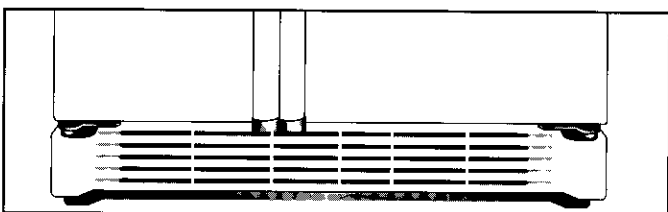

2. To level the refrigerator, use a screwdriver and turn roller adjusting screws clockwise to lower the cabinet or counterclockwise to raise the cabinet.

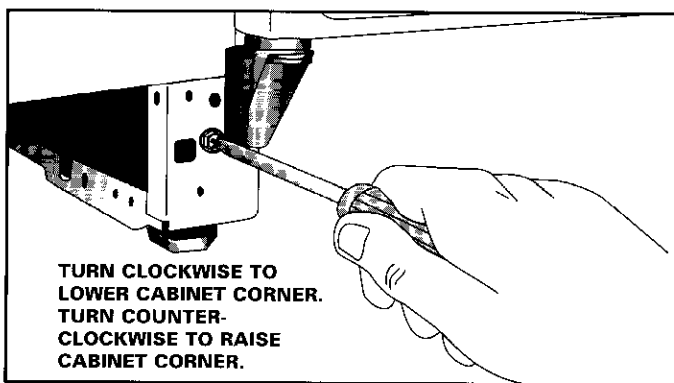

3. It is not necessary to lock the refrigerator in place. However, if that is desirable, turn one or both of the locking feet clockwise. They are located near the front wheels.

If the floor is not level and it is necessary to raise the rear of the cabinet, we suggest rolling the rear wheels onto a piece of plywood or other shim material.

4. To replace, center the clips in the cut-out areas and push in until the base grille snaps into place.

Connecting the Appliance

WARNING: This appliance is designed to operate on a normal 115 volt, 15 amp, 60 cycle line. There should be a separate, grounded circuit serving this appliance only. Do not use an extension cord.

This appliance is equipped with a three-pronged grounding plug for your protection against possible electrical shock hazards. It must be plugged into a grounding receptacle. Where a standard two-prong wall receptacle is encountered, it is the personal responsibility and obligation of the customer to have it replaced with a properly grounded three-prong wall receptacle. Do not under any circumstances, cut or remove the third (ground) prong from the power cord. Do not use an adapter plug.

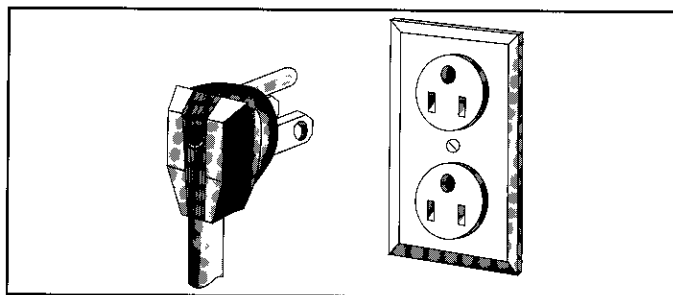

Energy Saving Tips

1. Locate the refrigerator away from heat producing appliances such as the range or dishwasher, heat vents and direct sunlight.
2. Level the refrigerator and do not block ventilation around the front grille.
3. Keep the freezer full to near capacity so less cold air will escape during door openings. When less than two-thirds full, place milk cartons half full of water in the freezer.
4. Let hot dishes cool slightly before putting into the refrigerator or freezer.
5. Cover liquids.
6. Wipe moisture from the outside of containers before placing them into the refrigerator.
7. Avoid opening the doors too often.

GENERAL FEATURES

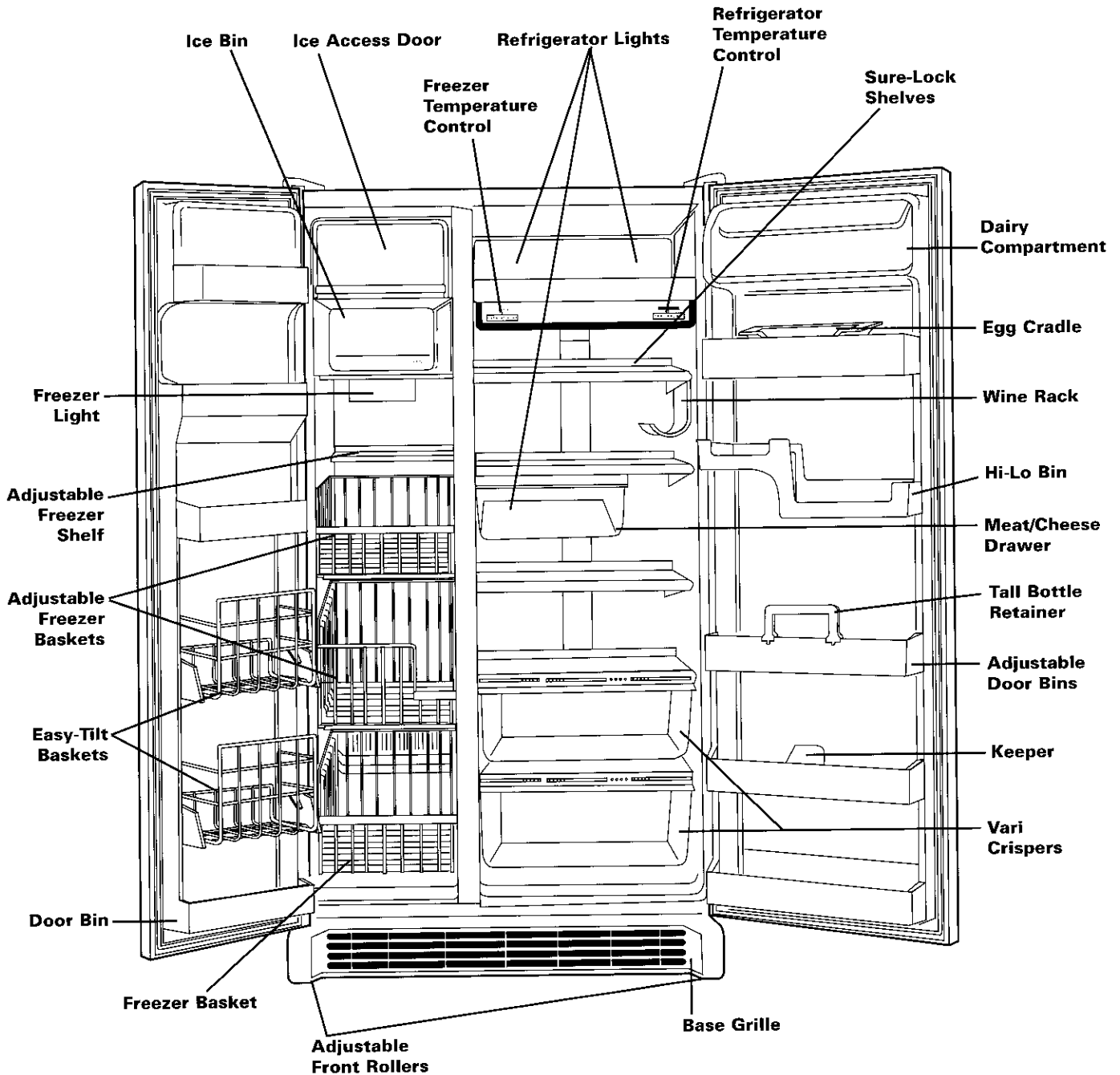

Features vary according to model.

OPERATING THE CONTROLS

Your new refrigerator has two controls: one for the refrigerator compartment and one for the freezer compartment. These controls are located at the top, rear of the refrigerator compartment.



Initial Setting of Controls

Freezer Control: This control has settings from A (warmest) to G (coldest). **Initially set this control to D.**

NOTE: The coldest freezer setting (G) is recommended for short term use only.

Refrigerator Control: This control has settings from 1 (warmest) to 11 (coldest). **Initially set this control to 6.** The refrigerator may run for several hours when you first start it. This is normal.

Let the refrigerator run at least 8 to 12 hours before adding food. A day or so after adding food, you may decide one or both compartments should be colder or warmer. If so, adjust the control(s) as instructed below.

Adjusting the Temperature Controls

Except when starting the refrigerator, **do not change either control more than one number or letter at a time.** Allow 24 hours for the temperature to stabilize before resetting. Changing either control will have some effect on the temperature of the other compartment.

Freezer too warm—Turn the freezer control to the succeeding letter. For example, turn the control from D to E.

Freezer too cold—Turn the freezer control to the preceding letter. For example, turn the control from D to C.

Refrigerator too warm—Turn the refrigerator control to the next higher number. For example, turn the control from 6 to 7.

Refrigerator too cold—Turn the refrigerator control to the next lower number. For example, turn the control from 6 to 5.

Warm Cabinet Surfaces

Some portions of the cabinet may be warm to the touch. This is a normal function of the refrigerator which helps prevent moisture from condensing on the cabinet. This condition will be more noticeable when you first start your refrigerator, during hot weather and after excessive or lengthy door openings.

ADJUSTING THE INTERIOR

Sure-Lock Shelves

The refrigerator shelves are adjustable, allowing you to arrange the shelving to fit your family's food storage needs. **Never attempt to adjust a shelf that is loaded with food.**

To remove the refrigerator shelf:

1. Grasp the shelf at the front with one hand and push up under the shelf back with the other hand.
2. Lift the shelf straight out.

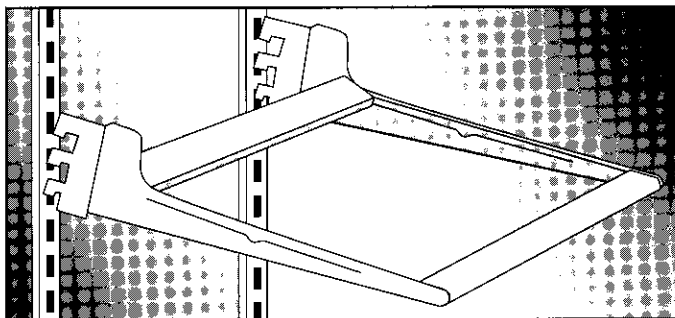

To replace the refrigerator shelf:

1. Keeping the shelf horizontal, guide the three support tabs into the slots in the shelf supports at the rear of the cabinet.
2. Lower the shelf until the tabs lock into position. Make sure the shelf is securely locked into position before loading it with food.

Easy-Glide Shelves

Grasp the front edge of the shelf and pull forward. Push in shelf to return to the original position.

Meat/Cheese Drawer Shelf

The shelf that holds the Meat/Cheese drawer can be placed in one of three positions. **It is necessary for the air inlet tube at the back of the refrigerator to line up at the top, middle or bottom of the air slots in the back of the Meat/Cheese drawer frame for the temperature control to work properly.** Set the temperature control to the coldest position when positioning the Meat/Cheese drawer. Once the shelf has been adjusted, replace the drawer and set the control to the desired setting (see page 5). **If not positioned correctly, items on the shelf below the drawer may freeze.**

Gallon Door Bins

The refrigerator door bins are adjustable and can be easily removed. They are a complete bin, so items may be carried in the bin without falling out.

Pick-Off Door Bins (22 and 24 cubic feet models)

To remove the door bins:

Lift the bin straight up. Tip out the bottom of the bin and pull out the bin.

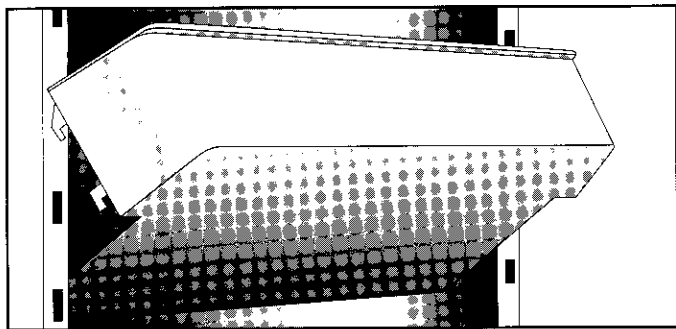

To replace the door bins:

Insert the top hooks first. Then push in and down.

NOTE: In models with pick-off bins, the bottom bin is fixed and not removable or adjustable.

Slide-Off Door Bins (27 cubic feet models)

To remove the door bins:

Using two hands, grasp the bin at the front and pull toward you.

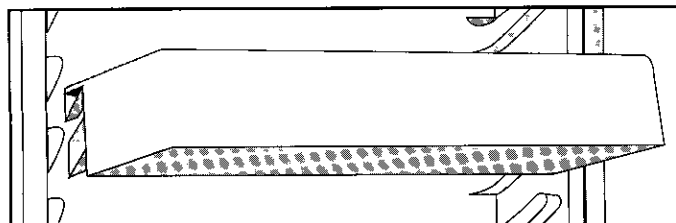

To replace the door bins:

Line up the top of the bin with the slides and **snap** the bin back in place.

NOTE: In models with slide-off bins, the dairy compartment bin is removable. Due to its shape, it fits only in the top position.

Hi-Lo Pick-Off Door Bin (22 and 24 cubic feet models)

This is a pick-off bin designed to accommodate short items in the raised section of the bin and taller items like milk and soda containers, in the bin area below.

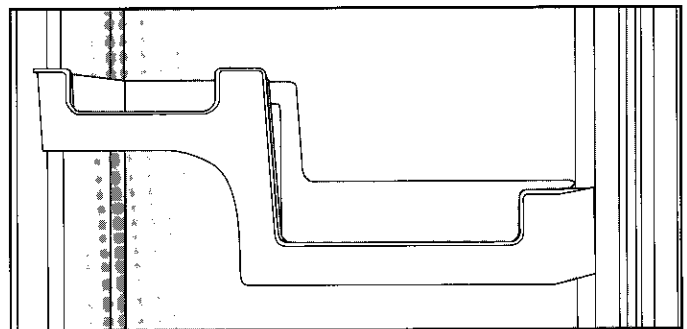

Easy-Tilt Freezer Door Baskets

Two easy-tilt freezer door baskets provide convenient storage for items that tend to shift or slide (such as bagged vegetables) when the door is opened and closed.

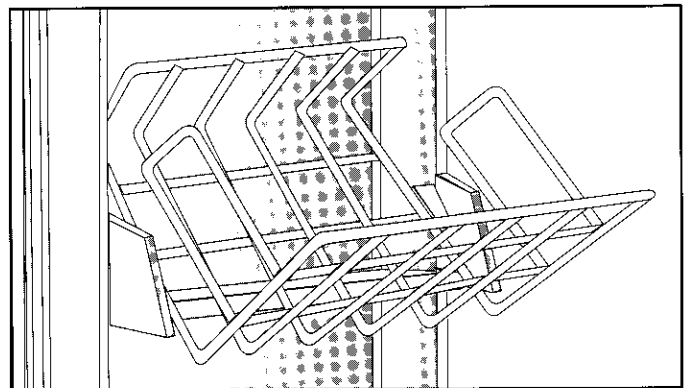

Keepers and Tall Bottle Retainer

Some refrigerator door bins have “keepers” to secure bottles and containers. The keepers help prevent items from tipping or falling when the door is opened and shut. Lift the keeper slightly to slide from side to side.

The tall bottle retainer is specially designed to prevent tall bottles from tipping forward (select models).

SPECIAL STORAGE AREAS

Freezer Shelf

The freezer shelf can be removed to accommodate large size packages and for cleaning.

To remove the shelf:

1. Lift up on the shelf and push to the right.
2. Tilt the left side of the shelf up and remove.

To replace the shelf:

1. Tilt the shelf and insert the right rod ends into the upper portion of the oblong holes in the freezer wall.

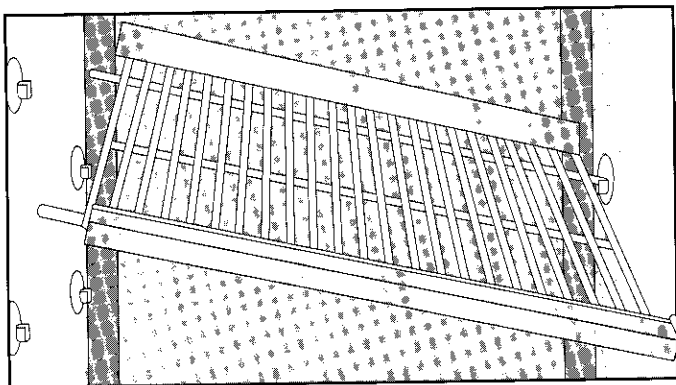

2. Lower the left side of the shelf and insert into the oblong holes in the left side of the freezer wall. Make sure the shelf is secure before loading.

Freezer Baskets

Your refrigerator has three freezer baskets—one shallow Easy Glide, one Pizza and one deep Easy Glide. Each glides out for more convenient access to the frozen food. All baskets can be removed for cleaning. In addition, the shallow Easy Glide and Pizza baskets can be adjusted up or down to accommodate various sized packages.

To remove the baskets:

1. Pull the basket toward you until it stops. Lift the front of the basket and pull until it stops again.
2. Lift the basket up and over the front tabs.

To replace the baskets:

Reverse the above procedure.

To adjust the shallow Easy Glide and Pizza baskets:

1. Remove the basket as directed previously.
2. Place one of the bottom two heavy wires in the track and replace the basket.

Crispers

The **Vari Crisper** allows the amount of moisture in the crisper to be controlled for storing either fruits or vegetables.

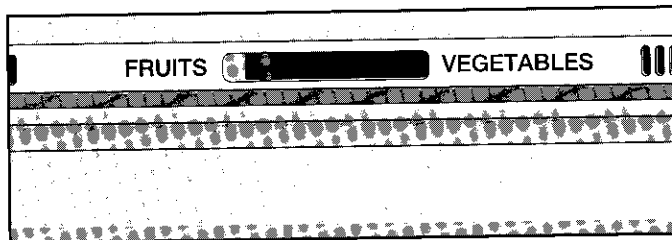

Setting the Vari Crisper Control

Move the slide control to "FRUITS" for a low moisture environment and to "VEGETABLES" for high moisture.

To remove the Crisper Drawers:

1. Pull out to the stop position.
2. Tilt up the drawer front and pull out.

To replace the Crisper Drawers:

1. Align the drawer rollers in tracks.
2. Lift the drawer front and push in.

To remove the Crisper Shelf:

1. Remove the crisper drawers.
2. Remove the glass insert. Reach in from the underside and tilt up. Carefully remove the insert.
3. Lift the front of the crisper shelf and pull out. It may be necessary to remove the lower refrigerator shelves so the crisper shelf can be tilted for removal.

To replace the Crisper Shelf:

Reverse the procedure for removing the crisper shelf.

Meat/Cheese Drawer

Meat and cheese need to be stored in the coldest part of the refrigerator to maximize storage time. The **Meat/Cheese** drawer provides these colder temperatures because air from the freezer is directed into the drawer.

Setting the Temperature Control

To regulate the amount of cold air entering the Meat/Cheese drawer, move the temperature slide control. Set the control to the "DELI/CHEESE" (right) position for storage of luncheon meat and cheese. Set the control to the "FRESH MEAT" (left) position to provide the lowest temperature for fresh meat storage.

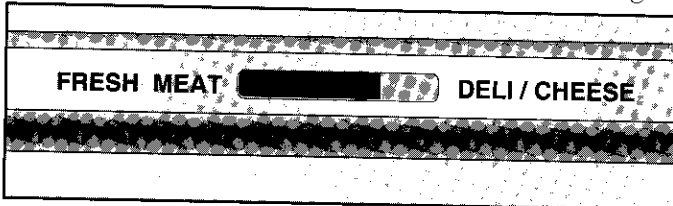

NOTE: If the shelf holding the Meat/Cheese drawer is not positioned correctly, items on the shelf below may freeze. Refer to page 4 on how to position the shelf.

To remove the Meat/Cheese Drawer:

1. Pull out to the stop position.
2. Tilt up the drawer front and pull out.

To replace the Meat/Cheese Drawer:

1. Align the drawer rollers in tracks.
2. Lift the drawer front and push in.

Wine Rack

Corked wines should be stored in a horizontal position to keep the cork moist. This prevents air from getting into the wine and spoiling it. The wine rack allows proper storage without taking up valuable shelf space. It may also be used for storing one liter containers of soda.

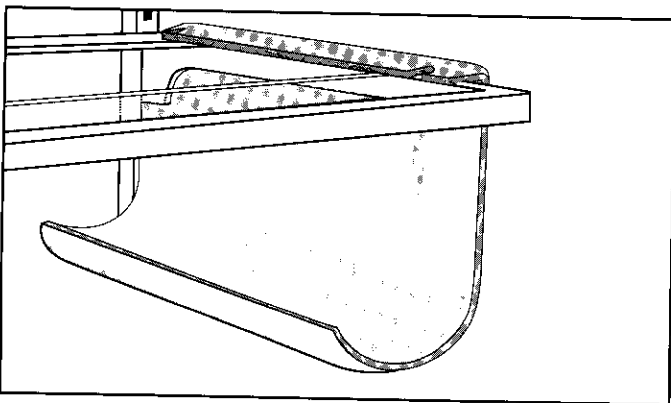

Covered Dairy Compartment

The butter dish is located in the covered dairy compartment. Use this area to store butter, margarine, or other dairy products. To use, raise the cover.

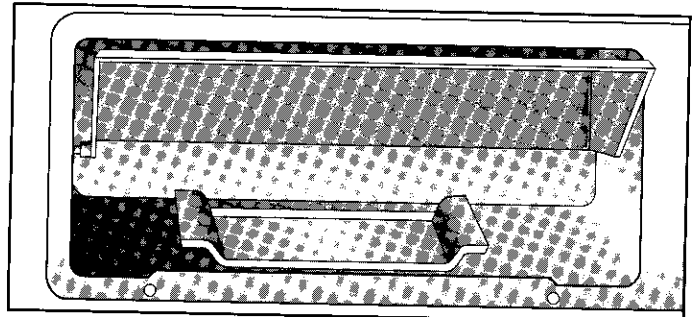

Egg Cradle

The egg cradle can be placed on a refrigerator shelf or stored in a door bin. It holds a "dozen-plus" eggs.

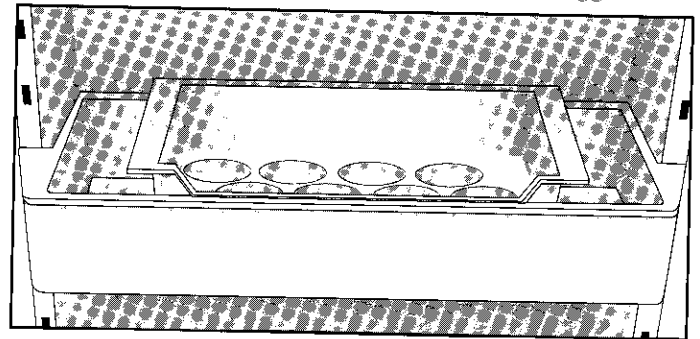

FOOD STORAGE TIPS

Fresh Food Storage

The fresh food compartment of a refrigerator should be kept between 34°F and 40°F with an optimum temperature of 37°F. To check the temperature, place an appliance thermometer in a glass of water and place in the center of the refrigerator. Check after 24 hours. If the temperature is above 40°F adjust the controls as explained on page 3.

Avoid overcrowding the refrigerator shelves. This reduces the circulation of air around the food and results in uneven cooling.

The storage requirements for different foods vary depending on the temperature and moisture needed. **Refer to the Food Storage Chart on page 8 for approximate storage times.** To maintain the best possible quality, consider the following:

Meat and Cheese

- To maximize storage time place these items in the Meat/Cheese drawer.

Fruits and Vegetables

- Storage in the crisper drawers traps moisture to help keep fruits and vegetables fresh. Refer to page 5 for setting the control.
- Fruit and vegetable quality affects the length of storage. Quality can vary from item to item, variety to variety and season to season. For example, a rainy growing season can cause lettuce to be brown when purchased or brown more quickly. Sort fruits and vegetables before storage and use bruised or soft items first. Discard those showing signs of decay.
- When storing vegetables, the crispers perform better if they are at least two-thirds full. If they are less than two-thirds full, store the vegetables in plastic bags or airtight containers to reduce moisture loss.
- Always wrap odorous foods such as onions and cabbage so the odor does not transfer to other foods.
- While vegetables need a certain amount of moisture to remain fresh, too much moisture can shorten storage times (especially lettuce). Be sure the vegetables are well drained before storing. It may also be helpful to place a layer of paper towels in the bottom of the bag to absorb any excess moisture.

Dairy Food

- Store butter and margarine in the Dairy Compartment found in the refrigerator door.
- Most dairy foods have freshness dates on their cartons for appropriate length of storage. Store these foods in the original carton and refrigerate immediately after purchasing and each use. Close carton lids tightly to keep out air and odors.
- Occasionally mold will develop on the surface of hard cheeses (Swiss, Cheddar, Parmesan). The moldy areas can be trimmed away and the remaining cheese will be flavorful and safe to eat.

Frozen Food Storage

The freezer compartment of a refrigerator should be kept at 0°F or lower. To check the freezer, place an appliance thermometer between the frozen packages and check after 24 hours. A freezer operates more efficiently when it is at least two-thirds full. If not this full, it will be helpful to fill milk cartons half full of water

and place them in the freezer. For the best results when freezing foods, follow these guidelines:

Packaging Foods for Freezing

- Select fresh, top-quality products.
- Use a freezer wrap that is air-, moisture- and vapor-proof. Some good choices are heavy-duty aluminum foil, freezer plastic wrap, polyethylene-coated freezer paper, freezer bags or airtight containers. Force as much air out of the packages as possible and be sure they are tightly sealed. Trapped air can cause the food to dry out, change color and develop an off-flavor (freezer burn).
- Do not refreeze meat that has completely thawed.

Loading the Freezer

- Avoid adding too much warm food to the freezer at one time. This slows the rate of freezing and can raise the temperature of frozen foods.
- Place packages in the coldest part of the freezer first (against the walls or bottom of the compartment) to ensure the food freezes as quickly as possible. Leave a little space between the packages so cold air can circulate.
- Avoid storing hard-to-freeze foods such as ice cream and orange juice on the freezer door shelves. These foods are best stored in the freezer interior where the temperature varies less with door openings.

Foods That Don't Freeze Well

- Some foods cannot be frozen successfully because the freezing causes them to deteriorate. These include:

potatoes (unless mashed)	mayonnaise
cream fillings	milk and cream
cooked egg whites	gelatin salads
sour cream	bananas
salad greens	citrus fruits
luncheon meat	
soft cheeses (cream, cottage, processed)	

Food Storage Chart (Storage times vary depending on type of packaging and storage temperature.)

Foods	Refrigerator	Freezer	Storage Tips
DAIRY PRODUCTS			
Butter	1-2 weeks	6-9 months	Wrap tightly or cover. Check carton date. Close tightly. Don't return unused portions to original container. Don't freeze cream unless whipped.
Milk & cream	1 week	Not recommended	
Cream cheese, cheese spread & cheese food	1-2 weeks	Not recommended	Wrap tightly. Some can be stored longer. Store in original carton. Check carton date.
Cottage cheese Sour cream	5-7 days 10 days	Not recommended	
Hard cheese (Swiss, Cheddar & Parmesan)	1-2 months	May become crumbly	Wrap tightly. Cut off any mold.
EGGS			
Eggs in the shell, Leftover yolks or whites	1 week 2-4 days	Not recommended 9-12 months	Refrigerate small ends down. For each cup of yolks to be frozen, add 1 tsp. sugar for use in sweet, or 1 tsp. salt for non-sweet dishes.
FRUITS			
Apples	1 month	6-12 months	May also store unripe or hard apples at 60-70°F. Ripen at room temperature before refrigerating. Bananas & avocados darken when refrigerated.
Bananas, pears, peaches, plums, avocados & apricots	3-5 days	6-12 months	
Berries, cherries	2-3 days	6-12 months	Store covered or in the crispers to prevent moisture loss.
Grapes	3-5 days		
Citrus fruits	1-2 weeks	Not recommended	May also store at 60-70°F. If refrigerated, store uncovered. Will not ripen after purchase. Use quickly.
Pineapples, cut	2-3 days	6-12 months	
VEGETABLES			
Asparagus	2-3 days	8-12 months	Don't wash before refrigerating. Store in crisper. Wrap odorous foods & refrigerate in crisper.
Brussels sprouts & broccoli	3-5 days	8-12 months	
Cabbage & celery	1-2 weeks	Not recommended	Wrap odorous foods & refrigerate in crisper. Wrap odorous foods & refrigerate in crisper.
Cauliflower & snap beans	1 week	8-12 months	
Carrots, parsnips, beets, radishes & turnips	2 weeks	8-12 months	Remove tops. Wrap odorous foods & refrigerate in the crisper.
Green peas & lima beans	3-5 days	8-12 months	Leave in pods & refrigerate.
Lettuce & salad greens	1 week	Not recommended	Wash. Drain well. Refrigerate in crisper. Wrap odorous foods & refrigerate in crisper.
Onions, green Peppers	3-5 days 1 week	8-12 months	
POULTRY & FISH			
Chicken	1-2 days	6-12 months	Keep in original packaging for refrigeration. Place in the Meat and Cheese Drawer. When freezing longer than 2 weeks, overwrap with freezer wrap.
Turkey, duck & goose	1-2 days	4-6 months	
Fish	1-2 days	1-2 months	
MEATS			
Bacon	7 days	1 month	Fresh meats can be kept in original packaging for refrigeration. Place in the Meat and Cheese Drawer. When freezing longer than 2 weeks, overwrap with freezer wrap.
Beef, ground	1-2 days	4-6 months	
Beef, roast & steak	3-5 days	9-12 months	Unopened, vacuum-packed luncheon meat may be kept up to 2 weeks in the Meat and Cheese Drawer.
Ham, whole	7 days	1-3 months	
half	5 days	1-3 months	Processed meats should be tightly wrapped and stored in the Meat and Cheese Drawer.
slices	3 days	1-2 months	
Lamb	3-5 days	9-12 months	Unopened, vacuum-packed luncheon meat may be kept up to 2 weeks in the Meat and Cheese Drawer.
Luncheon meat	3-5 days	Not recommended	
Pork	3-5 days	6-9 months	Processed meats should be tightly wrapped and stored in the Meat and Cheese Drawer.
Sausage, ground	1-2 days	1-3 months	
Sausage, smoked	7 days	Not recommended	Processed meats should be tightly wrapped and stored in the Meat and Cheese Drawer.
Veal	3-5 days	4-6 months	
Frankfurters	7 days	2 weeks	

Sources: United States Department of Agriculture; Food Marketing Institute; Cooperative Extension Service, Iowa State University

ICE AND WATER SERVICE

Automatic Ice Maker

Here are some things to keep in mind about the automatic ice maker's operation:

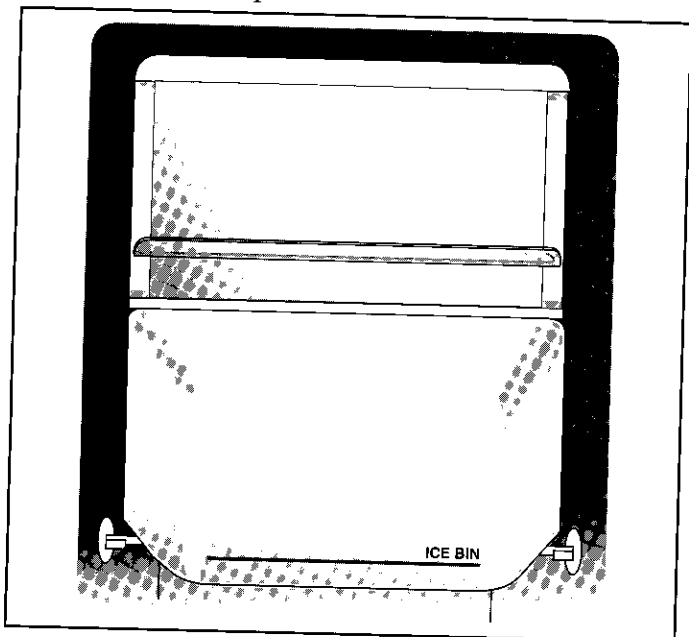

- To check the ice level or to gain access to the ice bin, lift the Ice Access door.
- To remove the ice bin, lift the front of the bin and pull forward. To avoid the ice maker dumping ice while the bin is removed, turn the ice maker off by lifting the wire lever.
- To replace the ice bin, push it straight back until it stops. Lift it up and over the stop, pushing it back into position. Make sure that the tabs that turn the auger, located at the back of the bin, are positioned between the prongs on the auger motor. Turn the ice maker on by lowering the wire arm.
- Beverage and foods should **not** be placed in the ice storage bin for quick chilling. These items can block the wire lever arm, causing the ice maker to malfunction.

Automatic Ice and Water Dispenser

The automatic ice and water dispenser offers a variety of convenience features. These are outlined below:

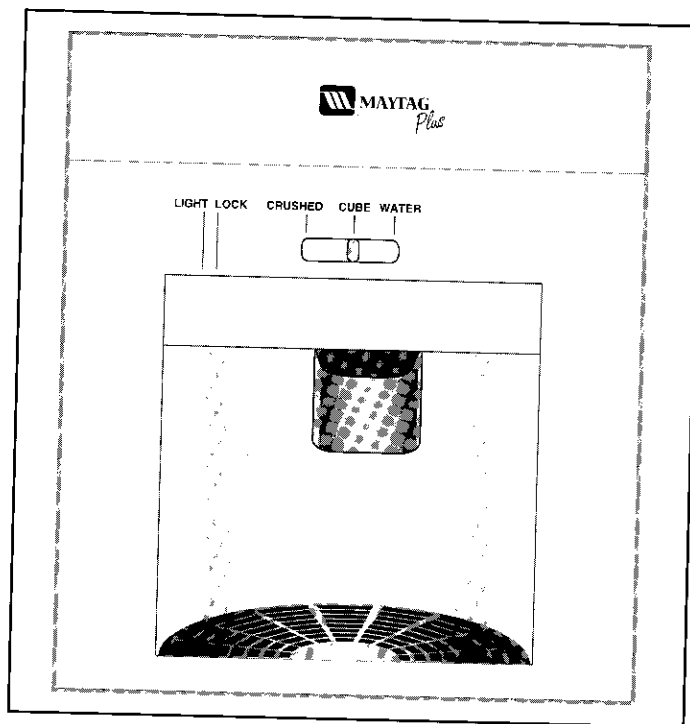

- After your refrigerator has been hooked up to the water supply, move the wire lever arm into the down position. This will start its operation. The ice maker will fill with water when the freezer reaches the proper temperature. With a newly installed refrigerator this could take up to 24 hours.
- Discard all the cubes from the first two or three batches made. These initial batches of ice cubes may be irregular in shape and discolored.
- When the ice cubes are ejected it is normal for several cubes to be joined together at the ends. They can easily be broken apart. The ice maker will continue to make ice until the supply of ice cubes raises the wire lever arm, shutting the ice maker off.
- To manually stop the operation of the ice maker, move the wire lever arm into the up position.
- Certain sounds may accompany the various operating cycles of the ice maker:
 - buzzing of the water valve
 - running of the water as the tray fills
 - rattling of the ice cubes falling into an empty ice bin
- If the ice is not used frequently, the ice cubes will become cloudy, shrink, stick together and taste stale. Empty the ice storage bin periodically and wash it in lukewarm water. Be sure to dry the bin before replacing it or the ice cubes will stick to the metal auger.

Water/Ice Control

For dispensing ice cubes, slide the control to the "CUBE" position (center).

For dispensing crushed ice, slide the control to the "CRUSHED" position (left).

For dispensing chilled water, slide the control completely to the "WATER" position (right).

To fill a glass or pitcher, position it against the top portion of the actuator pad and press. **Hold the container high in the dispenser opening to reduce ice from spilling.**

NOTE: When using the ice dispenser for the first time, discard the first two or three dozen cubes. When using the water dispenser for the first time, press the pad for one to two minutes to bleed the air from the water line. Discard the first five to six glasses of water dispensed. This will insure pure ice and fresh water for drinking.

Water from the dispenser is chilled, but not as cold as ice water. For colder water, simply add ice before dispensing water. Also, the first glass of water dispensed each time may be warmer than consecutive glasses. It will be cooler if a full glass of water is dispensed rather than a partial glass. To prevent splashing, fill a container with ice before adding liquid.

Ice Dispensing Tips

- When changing the control from CRUSHED to CUBE, or vice versa, some crushed ice or irregular shaped cubes may be in the storage bin and dispensed.
- If the ice dispenser is not used frequently, ice cubes may clump together and need to be broken apart or discarded.
- A slight pause may be noticed when dispensing crushed ice. This is normal because the ice is being channeled to the crusher. Crushed ice pieces will vary in size and shape.
- Do Not add ice to the storage bin which was not produced by your ice maker – it may not crush and /or dispense properly.
- Avoid operating the ice dispenser continuously for more than five minutes. Simply remove large quantities from the bin by hand.
- Avoid dispensing ice directly into thin, fine china or delicate crystal – they can crack or chip from the combined pressure of your hand pressing them against the actuator pad and ice dropping into the container.

To Stop Dispensing

Release the pressure on the pad and hold the container in position momentarily to catch the last pieces of ice or drops of water. The ice delivery door will remain open for a short time. When it closes you will hear a closing sound.

Spill Tray

Do not pour water into the grille at the bottom of the dispenser. This is a spill area, not a drain. Normal spills will evaporate in the recessed area below the spill shelf grille. Excessive spills should be wiped up after removing the grille.

Dispenser Light

When the pad is pressed, the light automatically turns on. To manually turn the light on and off, depress the dispenser light switch. It is located on the left side and recessed 1/2 inch up and behind the decorative panel.

Dispenser Pad-Lock

The dispenser pad-lock rocker switch, also located on the left side, will interrupt power to the water and ice dispenser so it cannot be used. The lock is recessed 3/4 inch up and back behind the decorative panel. Depress the switch to lock and unlock the dispenser.

NON-USE PERIODS

Vacations

If you will be gone for a month or less, leave the controls at the usual settings.

During longer absences:

- a) remove all food,
- b) shut off the ice maker (if installed) and the valve where you tapped into the water line to supply the refrigerator,
- c) disconnect the refrigerator from the electrical outlet,
- d) clean and dry the refrigerator thoroughly including the defrost pan,
- e) leave the doors open to prevent odors.

Moving

When moving, follow steps a–d under Vacations. In addition, remove and carefully pack any items that are easily removable. Ship the refrigerator in an upright position with the doors taped shut.

CARE AND CLEANING

Refer to the chart on page 13 when cleaning the refrigerator.

CAUTION: Disconnect the power cord before cleaning. Also, do not touch refrigerated surfaces with wet or damp hands. Damp objects stick to the cold metal surfaces. Before cleaning the freezer, allow it to warm up. Allow glass shelves to warm up before immersing in warm water.

Cleaning Under the Refrigerator

Your refrigerator can be rolled out for cleaning the floor underneath. Simply unlock the front roller locks (see page 1). Pull the refrigerator straight out from the wall.

Cleaning the Defrost Pan

The defrost water drains into a shallow pan beneath the cabinet and evaporates. This pan should be cleaned periodically with warm sudsy water.

To remove the defrost pan:

1. Remove the base grille (see page 1).
2. Lift the pan up and pull out.

To replace the defrost pan:

1. Position the side flanges to fit over the slide rails and press down on the center of the pan to snap in place.
2. Replace the base grille.

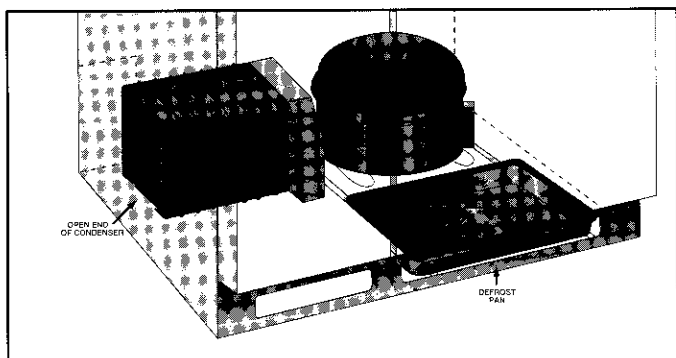

Replacing the Interior Lights

CAUTION: Disconnect the power cord before replacing light bulb(s). Wear gloves as protection against possible broken glass.

Refrigerator

Two upper lights are located behind the full width light shield at the top back of the refrigerator compartment. A lower refrigerator light is located behind the Meat/Cheese drawer on select models.

To replace the upper refrigerator bulbs:

1. Unplug the refrigerator.
2. Remove the light shield by grasping the bottom of the shield at each end and pull forward to remove.
3. Lift up and remove the shield.
4. Unscrew the bulb and replace with a 40 watt appliance bulb.
5. Replace the light shield by hooking the top of the shield over the plastic pins. Secure the bottom of the shield by pushing in on middle edges of the shield at both ends.

To replace the lower refrigerator bulb:

1. Unplug the refrigerator.
2. Remove the Meat/Cheese drawer.
3. Using two hands, spread the top and bottom of the light shield vertically away from each other and pull to the front to remove.
4. Unscrew the bulb and replace with a 40 watt showcase bulb.
5. Using two hands, spread the top and bottom of the light shield and push it into place, engaging the tabs into the slots.
6. Replace the Meat/Cheese drawer.

Freezer

The freezer light is located in the upper portion of the freezer compartment.

To replace the freezer bulb:

1. Unplug the refrigerator.
2. Remove the ice bin (see page 9) and the freezer shelf (see page 5).
3. Unhook the tabs on the top of the light shield by pressing in with your thumb on the center top of the light shield. Pivot the shield down.
4. Unscrew the bulb when cool and replace it with a standard 40 watt appliance bulb.
5. Pivot the shield up into place, snapping the tabs into the slots. Replace the freezer shelf and ice bin.

Ice and Water Dispenser

To replace the dispenser bulb:

1. Unplug the refrigerator.
2. Reach up behind the decorative panel on the right side, unscrew the bulb and replace it with a 7 watt appliance bulb.

Refrigerator Cleaning Chart

Cleaning Agents*

Many different cleaning agents are recommended for the various parts of Maytag refrigerators. The following brand names may help you make an appropriate selection:

1. Mild abrasive cleaners such as Bon Ami, Soft Scrub, Bar Keepers Friend, Cameo.
2. Mild liquid sprays such as Fantastik, Formula 409.
3. Glass cleaner such as Windex, Glass Plus.

DO NOT USE abrasive cleansing powders such as Comet or Zud, soap-filled scouring pads like S.O.S. or Brillo **except when indicated.**

No Clean™ commercial-duty Condenser

A clean condenser means more efficient refrigerator operation. Thanks to the unique design of the No Clean™ condenser there's no longer a need for routine condenser cleaning in normal home usage surroundings.

Some operating environments may be particularly dusty or greasy. In these situations, the condenser can be periodically cleaned to insure maximum efficiency.

Refrigerator Exterior		
Part	Cleaning Agents	Tips and Precautions
BASE GRILLE	Soap and water Mild liquid sprays Vacuum cleaner attachment	Remove the base grille by grasping the ends, lift and pull out. To replace, center the clips in the cut-out areas and push in until the base grille snaps into place.
CONDENSER	Cleaning brush (Part No. 20001017). Available from your dealer.	No need for cleaning unless environment is particularly greasy, dusty or there is significant pet traffic in the home.
DEFROST PAN	Soap and water	See page 11 on how to remove and replace.
DOOR HANDLES	Soap and water Mild liquid sprays	
PAINTED METAL SURFACES: CABINET, DOORS	Soap and water Mild liquid sprays	Do not wax plastic or vinyl parts.
BLACK DECORATOR PANELS	Glass cleaners Soft, clean, lint-free cloth (cotton diaper or cheesecloth)	The following glass cleaners clean these panels best without streaking: Glass Plus, S.O.S. Glass Cleaner, The Works Glass Cleaner and Glassmates Wipes®. Do not use paper towels or soiled cloths because panels can scratch easily.
Refrigerator & Freezer Interior		
DOOR GASKET	Baking soda and water Soap and water	Use 1-2 tablespoons baking soda per quart of water. Be sure to wring out excess water from sponge or cloth when cleaning around controls, lights, or electrical parts.
GLASS SHELVES	Soap and water Glass cleaner Mild liquid sprays Mild abrasive cleaners	Allow the glass to warm up to room temperature before immersing in warm water. Never use hot water.
INTERIOR AND DOOR LINER	Soap and water Baking soda and water	See above for baking soda solution. DO NOT use abrasive cleaners, concentrated detergents, bleaches, cleaning waxes, solvents or polish cleaners to clean the refrigerator interior.
DRAWERS, BINS, EGG CRADLE, ETC.	Soap and water	
WIRE SHELVES	Soap and water Mild liquid sprays.	

*Brand names of cleaning agents are trademarks of the respective manufacturers.

TO AVOID UNNECESSARY SERVICE CALLS...

Before calling a service technician, check the following list for possible troubles that you can remedy without difficulty.

WON'T RUN	<ul style="list-style-type: none"> • the temperature control turned to "Off" • the power cord not plugged in • no power at the electrical cord • the circuit breaker tripped or the house fuse blown
RUNS TOO LONG/ TOO FREQUENTLY	<ul style="list-style-type: none"> • modern refrigerators are larger and run colder, which requires more running time to provide more stable temperatures • the control set too cold • prolonged door openings • the base grille blocked • too many door openings • the door not sealing (due to a package or a container holding door open)
NOISY OPERATION	<ul style="list-style-type: none"> • fan noise — normal air flow • the defrost pan not positioned correctly • the cabinet not level • a weak floor
ODOR IN CABINET	<ul style="list-style-type: none"> • odor producing foods should be covered or wrapped • the interior needs cleaning • the defrost pan needs cleaning
WARM AIR FROM CABINET BOTTOM	<ul style="list-style-type: none"> • normal air flow for condenser
CABINET VIBRATES	<ul style="list-style-type: none"> • the cabinet not level • a weak floor
WATER ON BACK WALL OF REFRIGERATOR COMPARTMENT	<ul style="list-style-type: none"> • a normal defrost condition to channel moisture to the defrost pan
WATER ON FLOOR UNDER CABINET	<ul style="list-style-type: none"> • the defrost pan missing or not positioned properly
FOODS DRY OUT	<ul style="list-style-type: none"> • the packages not wrapped or sealed properly • the crisper not tightly closed
CABINET LIGHT NOT WORKING	<ul style="list-style-type: none"> • the bulb burned out • no power at the outlet
REFRIGERATOR COMPARTMENT TOO WARM	<ul style="list-style-type: none"> • the refrigerator control set too warm - see page 3 to adjust • prolonged door openings
REFRIGERATOR COMPARTMENT TOO COLD	<ul style="list-style-type: none"> • the refrigerator control set too cold - see page 3 to adjust
FREEZER COMPARTMENT TOO WARM	<ul style="list-style-type: none"> • the freezer control set too warm - see page 3 to adjust • prolonged door openings
SIZZLING SOUND IN FREEZER	<ul style="list-style-type: none"> • a normal sound caused by defrost water dripping on defrost mechanism
ICE CUBES EVAPORATE	<ul style="list-style-type: none"> • cold air moving over the ice cubes when not used regularly
AUTOMATIC ICE MAKER NOT OPERATING (OPTIONAL)	<ul style="list-style-type: none"> • the stop arm in OFF (up) position • the water supply turned off • the water pressure too low • the freezer too warm

NOTE: For further assistance contact your Maytag dealer or Maytag Customer Service: U.S. 1-800-688-9900
Canada 1-800-688-2002

MAYTAG REFRIGERATOR WARRANTY

Full One Year Warranty

For **one (1) year** from the date of original retail purchase, any part that fails in normal home use will be repaired or replaced free of charge.

Ice Maker – when purchased with the refrigerator and installed by the dealer the ice maker will be considered part of the refrigerator for warranty purposes.

Limited Warranty — Major Refrigeration Components

Second thru Fifth Year:

After the first year from the date of original retail purchase, through the fifth year, Maytag Appliances will repair or replace, at its option, free of charge for parts and labor, any part of the sealed refrigeration system (consisting of the compressor, evaporator, condenser, drier and connecting tubing) and the cabinet liner (exclusive of the door liner) which fail in normal home use. Mileage and transportation charges, if required, shall be the responsibility of the owner.

Limited Warranty — Other Parts:

Second Year:

Parts other than major refrigeration components which fail in normal home use during the second year following the date of original retail purchase will be repaired or provided free of charge for the part itself, with the owner paying all other costs, including labor, mileage and transportation.

Please note: The full warranty and the limited warranties apply when the refrigerator is located in the United States or Canada. Refrigerators located elsewhere are covered by the limited warranties only including parts that fail during the first year.

LIMITATIONS OF LIABILITY

The warrantor shall not be liable for any incidental or consequential damages, including food loss. Some states do not allow the exclusion or limitation of consequential damages, so the above limitation or exclusion may not apply to you.

To Receive Warranty Service

To locate an authorized service company in your area contact the Maytag dealer from whom your appliance was purchased; or call Maytag Customer Service at the number listed below. Should you not receive satisfactory warranty service, please call or write:

Maytag Customer Assistance
c/o Maytag Customer Service
P.O. Box 2370
Cleveland, TN 37320-2370
U.S. **1-800-688-9900**
CANADA **1-800-688-2002**

When contacting Maytag Customer Service be sure to provide the model and serial number of your appliance, the name and address of the dealer from whom you purchased the appliance, and the date of purchase.

The specific warranties expressed above are the ONLY warranties provided by the manufacturer. This warranty gives you specific legal rights, and you may also have other rights that vary from state to state.

Should you still have a problem, write to: Major Appliance Consumer Action Program, 20 North Wacker Drive, Chicago, Illinois 60606. MACAP is an industry sponsored but independent group of consumer experts who receive and act on complaints from appliance owners.

NOTE: When writing about an unsolved service problem, please include the following information:

- (a) Your name, address and telephone number;
- (b) Model number, serial number, and revision number (found on the top front interior of the refrigerator compartment);
- (c) Name and address of your dealer and the date the appliance was bought;
- (d) A clear description of the problem you are having.

MAYTAG • One Dependability Square • Newton, Iowa 50208

MAYTAG REFRIGERATOR WARRANTY

Full One Year Warranty

For **one (1) year** from the date of original retail purchase, any part which fails in normal home use will be repaired or replaced free of charge.

Ice Maker – when purchased with the refrigerator and installed by the dealer the ice maker will be considered part of the refrigerator for warranty purposes.

Limited Warranty — Major Refrigeration Components

Second thru Fifth Year:

After the first year from the date of original retail purchase, through the fifth year, Maytag will repair or replace, at Maytag's option, free of charge for parts and labor, any part of the sealed refrigeration system (consisting of the compressor, evaporator, condenser, drier and connecting tubing) and the cabinet liner (exclusive of the door liner) which fail in normal home use. Mileage and transportation charges, if required, shall be the responsibility of the owner.

Limited Warranty — Other Parts:

Second Year:

Other parts which fail in normal home use during the second year following the date of original retail purchase will be repaired or provided free of charge for the part itself, with the owner paying all other costs, including labor, mileage and transportation.

Please note: The full warranty and the limited warranties apply when the refrigerator is located in the United States or Canada. Refrigerators located elsewhere are covered by the limited warranties only including parts that fail during the first year.

LIMITATIONS OF LIABILITY

The warrantor shall not be liable for any incidental or consequential damages, including food loss. Some states do not allow the exclusion or limitation of consequential damages, so the above limitation or exclusion may not apply to you.

To Receive Warranty Service

To locate an authorized service company in your area contact the Maytag dealer from whom your appliance was purchased; or call Maytag Customer Service at the number listed below. Should you not receive satisfactory warranty service, please call or write:

Maytag Customer Assistance
Maytag Customer Service
P.O. Box 2370
Cleveland, TN 37320-2370
U.S. 1-800-688-9900
CANADA 1-800-688-2002

When contacting Customer Service be sure to provide the model and serial number of your appliance, the name and address of the dealer from whom you purchased the appliance, and the date of purchase.

The specific warranties expressed above are the ONLY warranties provided by the manufacturer. This warranty gives you specific legal rights, and you may also have other rights that vary from state to state.

Should you still have a problem, write to: Major Appliance Consumer Action Program, 20 North Wacker Drive, Chicago, Illinois 60606. MACAP is an industry sponsored but independent group of consumer experts who receive and act on complaints from appliance owners.

NOTE: When writing about an unsolved service problem, please include the following information:

- (a) Your name, address and telephone number;
- (b) Model number, serial number, and revision number (found on the top front interior of the refrigerator compartment);
- (c) Name and address of your dealer and the date the appliance was bought;
- (d) A clear description of the problem you are having.

MAYTAG • One Dependability Square • Newton, Iowa 50208

Refrigerator Cleaning Chart

Cleaning Agents*

Many different cleaning agents are recommended for the various parts of Maytag refrigerators. The following brand names may help you make an appropriate selection:

1. Mild abrasive cleaners such as Bon Ami, Soft Scrub, Bar Keepers Friend, Cameo.
2. Mild liquid sprays such as Fantastik, Formula 409.
3. Glass cleaner such as Windex, Glass Plus.
4. Appliance wax such as Jubilee.
5. Cleanbright #27 Liquid Ebony

DO NOT USE abrasive cleansing powders such as Comet or Zud, soap-filled scouring pads like S.O.S. or Brillo **except when indicated**. See pages 5-7 on how to remove and replace specific parts.

Refrigerator Exterior		
Part	Cleaning Agents	Tips and Precautions
Base grille	Soap and water Mild liquid sprays Vacuum cleaner attachment	To remove grasp the bottom edge near each end and pull out. To replace, angle the top (wide portion) up and in. Push in on the bottom until it snaps into place.
Condenser	Vacuum cleaner attachment	The area around the condenser should be cleaned at least once a year for efficient operation. See page 14 for more information.
Defrost pan	Soap and water	See page 14 on how to remove and replace.
Door handles	Soap and water Mild liquid sprays	
Painted metal surfaces: Cabinet, doors	Soap and water Mild liquid sprays Appliance wax	Wax at least once a year. Do not wax plastic or vinyl parts.
Black decorator panels	Glass cleaners Soft, clean, lint-free cloth (cotton diaper or cheesecloth) Cleanbright #27 Liquid Ebony	The following glass cleaners clean these panels best without streaking: Glass Plus, S.O.S. Glass Cleaner, The Works Glass Cleaner and Glassmates Wipes*. Do not use paper towels or soiled cloths because panels can scratch easily. To remove minor scratches, use Liquid Ebony according to instructions given on Maytag Fact Sheet (Form No. 266YG), available at no charge.
Refrigerator & Freezer Interior		
Door gasket	Baking soda and water Soap and water	Use 1-2 tablespoons baking soda per quart of water. Be sure to wring out excess water from sponge or cloth when cleaning around controls, lights, or electrical parts.
Glass shelves	Soap and water Glass cleaner Mild liquid sprays Mild abrasive cleaners	Allow the glass to warm up to room temperature before immersing in warm water. Never use hot water.
Interior and door liner	Soap and water Baking soda and water	See above for baking soda solution. DO NOT use abrasive cleaners, concentrated detergents, bleaches, cleaning waxes, solvents or polish cleaners to clean the refrigerator interior.
Crispers, door bins, egg cradle, wine rack, meat/cheese drawers, etc.	Soap and water	
Wire shelves/baskets	Soap and water Mild liquid sprays.	

*Brand names of cleaning agents are trademarks of the respective manufacturers.

NON-USE PERIODS

Vacations

If you will be gone for a month or less, leave the controls at the usual settings.

During longer absences:

- a) remove all food,
- b) shut off the ice maker and the valve where you tapped into the water line to supply the refrigerator,
- c) drain all water from the water dispenser,
- d) disconnect the refrigerator from the electrical outlet,
- e) clean and dry the refrigerator thoroughly, including the defrost pan,
- f) leave the doors open to prevent odors.

Moving

When moving, follow steps a–e under Vacations. In addition, remove and carefully pack any items that are easily removable. Ship the refrigerator in an upright position with the doors taped shut.

IMPORTANT PERSONAL SAFETY INSTRUCTIONS

1. To prevent the possibility of hazard due to electrical shock, never plug the refrigerator into a receptacle which has not been grounded adequately and in accordance with the local and national electrical codes. See the grounding instructions on page 2.
2. Unplug the refrigerator before cleaning the condenser or replacing a light bulb.
3. In case of power failure, minimize door openings. If the power failure is of a long duration, protect the food by placing blocks of dry ice on top of the packages or check with a local frozen foods locker plant about temporary storage. Frozen foods which have thawed completely should not be refrozen.
4. Any electrical service cord that becomes frayed or damaged should be immediately repaired or replaced. Never unplug your appliance by pulling on the power cord.
5. Your refrigerator should not be operated in the presence of explosive fumes.
6. Remove the doors from any out-of-use refrigerator to prevent child entrapment and suffocation.
7. Children should not climb, hang or stand on the shelves of this refrigerator.

TO AVOID UNNECESSARY SERVICE CALLS...

Before calling a service technician, check the following list for possible troubles that you can remedy without difficulty.

The refrigerator won't run	<ul style="list-style-type: none"> the temperature control turned to "Off" the power cord not plugged in no power at the electrical cord the circuit breaker tripped or the house fuse blown
The refrigerator runs too long/too frequently	<ul style="list-style-type: none"> modern refrigerators are larger and run colder, which requires more running time to provide more stable temperatures the condenser needs cleaning (see page 13) the control(s) set too cold prolonged door openings the base grille blocked too many door openings the door not sealing (due to a package or a container holding door open)
Noisy operation <i>NOTE:</i> Additional motors and controls are used to provide improved performance. Therefore, normal operating sounds may be more noticeable than on the model it replaced.	<ul style="list-style-type: none"> fan noise — normal air flow the defrost pan not positioned correctly the cabinet not level a weak floor
Odor in the cabinet	<ul style="list-style-type: none"> odor producing foods should be covered or wrapped the interior needs cleaning the defrost pan needs cleaning
Warm air from the cabinet bottom	<ul style="list-style-type: none"> normal air flow for condenser
The cabinet vibrates	<ul style="list-style-type: none"> the cabinet not level a weak floor
Water on the floor under the cabinet	<ul style="list-style-type: none"> the defrost pan missing or not positioned properly
Foods dry out	<ul style="list-style-type: none"> the packages not wrapped or sealed properly the crisper not tightly closed
The cabinet light not working	<ul style="list-style-type: none"> the bulb burned out no power at the outlet
The refrigerator compartment too warm	<ul style="list-style-type: none"> the refrigerator control set too warm prolonged door openings
The refrigerator compartment too cold	<ul style="list-style-type: none"> the refrigerator control set too cold
The freezer compartment too warm	<ul style="list-style-type: none"> the freezer control set too warm prolonged door openings
Sizzling sound in the freezer	<ul style="list-style-type: none"> a normal sound caused by defrost water dripping on defrost mechanism
Moisture collects on the outside surface	<ul style="list-style-type: none"> hot humid weather increases condensation
The ice cubes evaporate	<ul style="list-style-type: none"> cold air moving over the ice cubes when not used regularly
The automatic ice maker not operating	<ul style="list-style-type: none"> the stop arm in OFF (up) position the water supply turned off the water pressure too low the freezer too warm
The ice dispenser not operating	<ul style="list-style-type: none"> an ice jam in the dispenser (clear with plastic or wooden utensil) the ice maker not operating the pad-lock switch actuated (depress switch to check) the ice clumped in bin (break-up or discard) an ice jam in crusher (remove ice from storage bin and turn auger by hand)
The water dispenser not operating	<ul style="list-style-type: none"> the water supply turned off the water pressure too low the pad-lock switch actuated (depress switch to check)

If after checking the list, the appliance still doesn't seem to operate properly, call your Maytag dealer's service department or the service department recommended.

REFRIGERATOR WARRANTY

Full One Year Warranty

For **one (1) year** from the date of original retail purchase, any part which fails in normal home use will be repaired or replaced free of charge.

Limited Warranty

Second thru Fifth Year — major refrigeration components:

After the first year and through the fifth year after the date of original retail purchase Maytag will repair or replace, at its option, free of charge to the owner for parts and labor any part of the sealed refrigeration system (consisting of the compressor, evaporator, condenser, drier and connecting tubing) and the cabinet liner (exclusive of the door liner) which fails in normal home use. Trip charges, travel and transportation, if required, shall be the responsibility of the owner.

Second Year — other parts:

Other parts which fail in normal home use during the second year following date of original retail purchase will be repaired or replaced free of charge for the part itself, with the owner paying all other costs, including labor and trip charges.

Ice Maker – when purchased with the refrigerator and installed by the dealer the ice maker will be considered part of the refrigerator for warranty purposes.

This full warranty and the limited warranty apply only when the appliance is located in the United States or Canada.

LIMITATION OF LIABILITY

Maytag Company shall not be liable for any incidental or consequential damages, including food loss. Some states do not allow the exclusion or limitations of consequential damages, so the above limitations or exclusion may not apply to you.

This Warranty gives you specific legal rights, and you may also have other rights which vary from state to state.

To Receive Warranty Service

- First:** Call or write the MAYTAG dealer from whom your appliance was purchased or the authorized service firm designated by the dealer.
- If you have moved from the selling dealer's service area call or write any authorized MAYTAG dealer or authorized service firm at your new location. Check the telephone directory yellow pages to identify the dealer or service firm in your area.
- Second:** Should your contact with the dealer or the service firm fail to satisfactorily resolve the problem, contact the manager of the dealership or the manager of the service firm for assistance.
- Third:** Should you not receive satisfactory warranty service from one of the above or need help in identifying an authorized service firm write:
- MAYCOR Appliance Parts and Service Company
A Division of Maytag Corporation
P.O. Box 2370
Cleveland, TN 37311

Arrangements for warranty service will be made. If the problem is urgent, call MAYCOR at (615) 472-3333.

When contacting MAYCOR be sure to include the model and serial number of your appliance, the name and address of the dealer from whom you purchased the appliance and the date of purchase.

Should you still have a problem, write to: Major Appliance Consumer Action Panel, 20 North Wacker Drive, Chicago, Illinois 60606. MACAP is an industry sponsored but independent group of consumer experts who receive and act on complaints from appliance owners.

NOTE: When writing about an unsolved service problem, please include the following information:

- Your name, address and telephone number;
- Model number, serial number, and bill of material number (found on the top front interior of the refrigerator compartment);
- Name and address of your dealer and the date the appliance was bought;
- A clear description of the problem you are having.

MAYTAG COMPANY • Newton, Iowa 50208

Free Manuals Download Website

<http://myh66.com>

<http://usermanuals.us>

<http://www.somanuals.com>

<http://www.4manuals.cc>

<http://www.manual-lib.com>

<http://www.404manual.com>

<http://www.luxmanual.com>

<http://aubethermostatmanual.com>

Golf course search by state

<http://golfingnear.com>

Email search by domain

<http://emailbydomain.com>

Auto manuals search

<http://auto.somanuals.com>

TV manuals search

<http://tv.somanuals.com>