

# INSTRUCTION MANUAL

## 6", 8" & 10" Starfinder Reflecting Telescopes



**Meade Instruments Corporation**

## WARNING!

Never use the Meade Starfinder telescope to look at the Sun! Looking at or near the Sun will cause *instant* and *irreversible* damage to your eye. Eye damage is often painless, so there is no warning to the observer that damage has occurred until it is too late. Do not point a telescope or its viewfinder at or near the Sun. Do not look through a telescope or its viewfinder as it is moving. Children should always have adult supervision while observing.

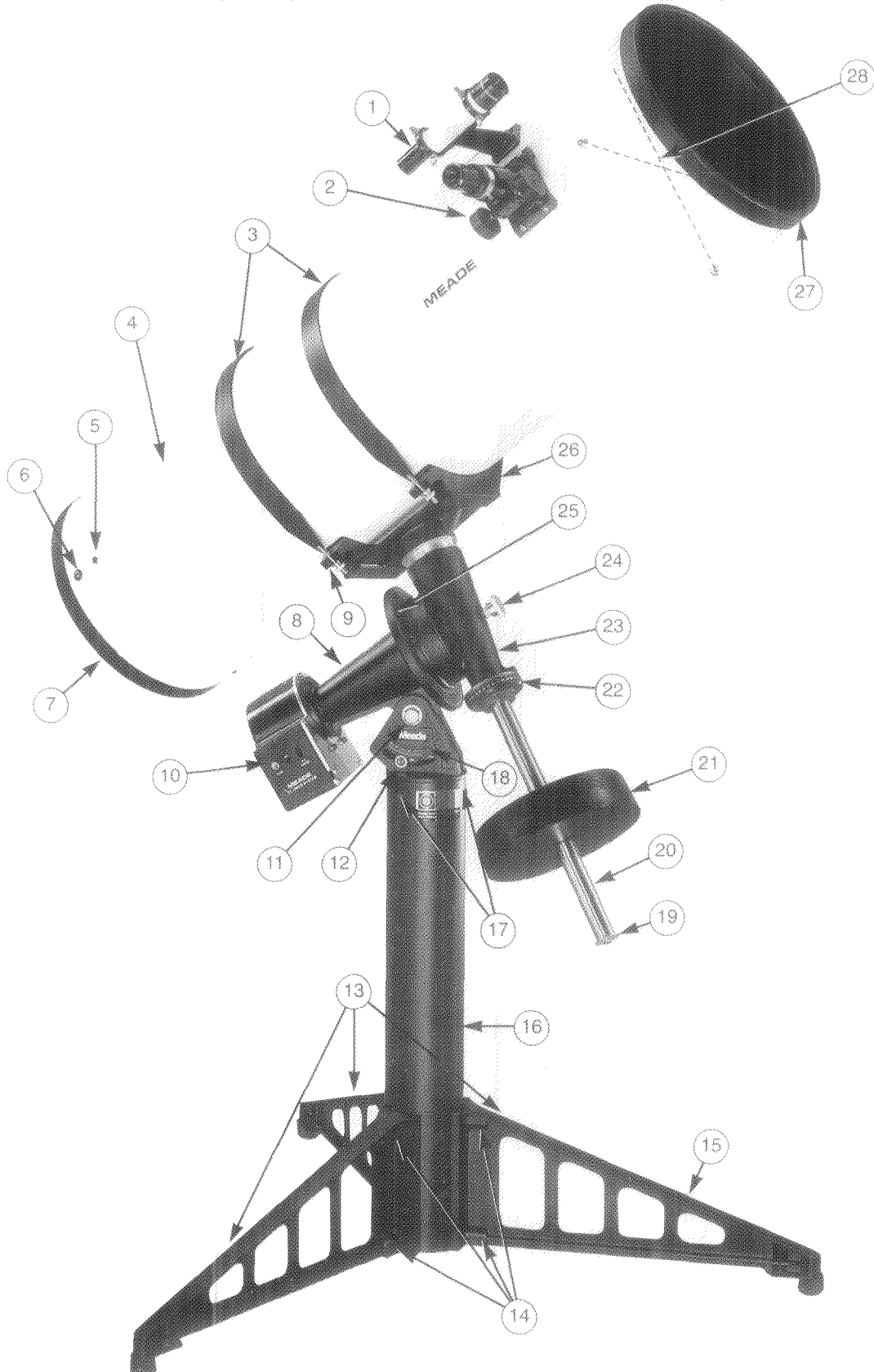

Fig. 1: The Meade 10" Starfinder Reflecting Telescope

**Captions for Fig. 1**

1. Viewfinder
2. 2" Focuser
3. Telescope mounting straps
4. Optical tube
5. Mirror position for prime focus photography ("B")
6. Standard mirror position ("A")
7. Primary mirror and mirror cell (inside tube)
8. Polar casting
9. Knurled thumb nut
10. Motor drive/Control panel
11. Primary latitude locking bolt
12. Latitude hex screw
13. Tripod legs
14. Tripod attachment bolts (inside pier)
15. North-pointing tripod leg
16. Pier
17. Pier-to-pier cap hex buttonhead screws
18. Latitude scale
19. Counterweight safety washer
20. Declination shaft
21. Counterweight
22. Declination setting circle
23. Declination casting
24. Declination lock knob
25. Right Ascension setting circle
26. Saddle plate
27. End rings
28. Spider/diagonal holder (inside tube)

**Contents**

**6", 8" and 10" Starfinder Equatorial Telescopes**

Introduction . . . . .	4
Parts Listing and Assembly . . . . .	4
Tripod . . . . .	4
Adjusting the Latitude. . . . .	4
Attaching the Mounting Straps . . . . .	4
Mounting the Counterweights . . . . .	4
Attaching the Focuser . . . . .	4
Attaching the Viewfinder. . . . .	4
Mounting the Primary Mirror. . . . .	4
Mounting the Optical Tube onto the Pier. . . . .	5
Balancing the Telescope . . . . .	5
Control Panel. . . . .	5
R.A. Encoder Port . . . . .	5
On/Off Switch. . . . .	5
Installing the Batteries . . . . .	5
12vDC Outlet . . . . .	5
The Viewfinder. . . . .	5
Focusing the Viewfinder. . . . .	5
Aligning the Viewfinder. . . . .	6
Using the Viewfinder . . . . .	6
Magnification . . . . .	6
Astronomical Observing . . . . .	6
Celestial Coordinates: Declination and Right Ascension	6
Polar Alignment . . . . .	7
How to Locate Objects in the Night Sky . . . . .	8
Motor Drive . . . . .	8
Southern Hemisphere Operations. . . . .	8
Setting Circles . . . . .	8
Observing Tips. . . . .	9
Astrophotography . . . . .	9
Optional Accessories . . . . .	10
Telescope Maintenance and Servicing . . . . .	11
Care of Optics and Main Tube . . . . .	11
Cleaning the Optics . . . . .	11
Cleaning the Optical Tube. . . . .	11
Collimation of the Optical System . . . . .	11
Correct Collimation. . . . .	11
Spider Vane Adjustments . . . . .	12
Secondary Mirror Adjustments . . . . .	12
Primary Mirror Adjustments. . . . .	12
Star Testing the Collimation . . . . .	13
Telescope Tracking . . . . .	13
Power Supply. . . . .	13
Slow Blow Fuse . . . . .	13
Balance . . . . .	13
Clutch Pressure Plate. . . . .	13
Worm Block . . . . .	13
Meade Customer Service. . . . .	13
Specifications . . . . .	14

® The name 'Meade' and the Meade logo are trademarks registered with the U.S. Patent Office and in principal countries throughout the world.

© 1999 Meade Instruments Corporation

## INTRODUCTION

The Starfinder Equatorial telescope will open up the skies for a breathtaking array of visual observations. Galaxies, nebulae, star clusters — in all their variations of form, color, and extent — as well as the Moon, planets, comets and other objects within the solar system, may be studied in great detail. For those interested in photography, excellent results can be obtained using the optional Meade camera adapter\* and a 35mm camera body.

This manual is designed for the 6", 8" and 10" Starfinder Equatorial Reflecting Telescopes. With the exception of a few assembly operations and features, the three telescopes are almost identical operationally. When differences in procedures occur, they are clearly noted. Most standard and optional accessories are interchangeable between the three telescopes. For optimal enjoyment of the telescope, please take a few minutes to read this manual and become familiar with all of the instrument's capabilities.

## PARTS LISTING AND ASSEMBLY

When first opening the packing boxes, note carefully the following parts included with the Starfinder Reflecting Telescope:

- Carton #1:
  - Optical tube assembly with mounting straps
  - Primary mirror mounted in its cell.

**CAUTION: The primary mirror must be handled with special care. Never touch its reflective surface or place the mirror where it could be damaged. Save all original packing materials; if it is ever necessary to ship the telescope, these materials will help to assure that no shipping damage will occur.**

- Carton #2:
  - Equatorial head with pier and motor attached
  - Focuser
  - 6 x 30mm viewfinder
  - Three tripod legs
  - 25mm eyepiece
 All necessary hardware.
- Carton #3:
  - 10 lb counterweight (6" and 8" models)
  - 5 lb counterweight (8" model only)
  - 25 lb counterweight (10" model only)

To assemble the telescope, follow these steps:

- 1. Tripod:** Attach the tripod legs (13, Fig. 1) to the pier (16, Fig. 1) using the wing nuts provided. For a more rigid or permanent assembly, use the hex head nuts and tighten with pliers or wrench.
- 2. Adjusting the Latitude:** Adjust the polar axis to your approximate latitude by loosening the primary latitude locking bolt (1, Fig. 2) and the latitude hex screw (3, Fig. 2) located at the top of the pier. Rotate the mount about the lock bolt until the center of the latitude hex screw is aligned with the latitude of your viewing location. (Degrees of latitude are shown on most maps.) Once aligned on the correct latitude, tighten the primary latitude locking bolt and the latitude hex screw.
- 3. Attaching the Mounting Straps:** Remove the mounting straps (3, Fig. 1) from the optical tube assembly and attach them to the saddle plate (26, Fig. 1) using the two upper block saddle screws.

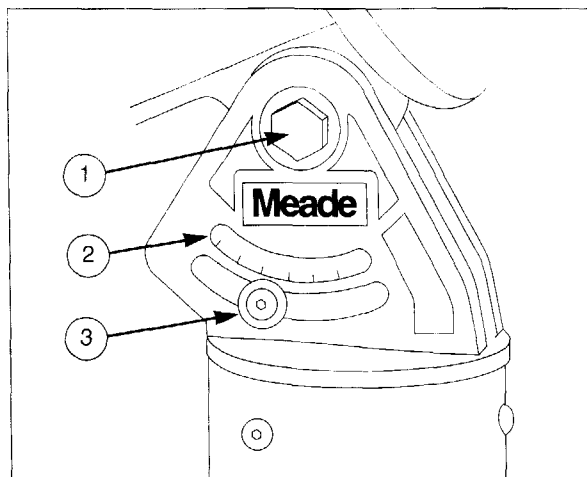

**Fig. 2:** Closeup of Latitude Adjustment. (1) Primary Latitude Locking Bolt; (2) Latitude Scale; (3) Latitude Hex Screw.

- 4. Mounting the Counterweights:** With a screwdriver, unscrew the flathead screw at the end of the declination shaft (20, Fig. 1) and remove the counterweight safety washer (19, Fig. 1). Slide the counterweight (21, Fig. 1) onto the declination shaft (20, Fig. 1) and lock it in place about one quarter of the way up the shaft. (The 6" model includes one 10-lb counterweight; The 8" model includes an additional 5-lb counterweight — lock this counterweight just under the 10-lb weight. The 10" model requires only one 25-lb counterweight.)

**CAUTION: Be sure to secure the counterweight safety washer (19, Fig. 1) onto the end of the declination shaft by placing the washer at the end of the shaft and replacing the flathead screw. The counterweights should never be removed with the optical tube in place!**

- 5. Attaching the Focuser:** Lay the optical tube flat on a floor. Align the holes in the focuser assembly (2, Fig. 1) with the pre-drilled holes in the optical tube. From the provided hardware, place the slotted pan head bolts through the holes. Carefully reach into the optical tube and attach a hex jam nut and washer to each bolt. Tighten the bolts, but do not overtighten; a firm feel is sufficient.
- 6. Attaching the Viewfinder:** With the optical tube lying flat on the floor, align the holes in the viewfinder bracket with the pre-drilled holes in the optical tube. From the supplied hardware, place a button socket screw through each of the holes. Carefully reach into the optical tube and attach a washer and hex jam nut onto each screw. Tighten the screws. As with the focuser, a firm feel is sufficient. Overtightening may result in damage to the tube's finish. Aligning the viewfinder will be discussed later in this manual.
- 7. Mounting the Primary Mirror:** Remove the black plastic end ring (7, Fig. 1) from the rear of the telescope. This ring is press-fitted in place; no tools are needed. The tube has been drilled to mount the primary mirror cell (7, Fig. 1) in one of two possible positions:

Position A: The rear set of mounting holes (6, Fig. 1) correctly positions the mirror for visual observing.

Position B: The forward set of mounting holes (5, Fig. 1) towards the focuser, correctly positions the primary mirror for prime-focus and eyepiece-projection photography.

For now, mount the mirror in Position A. Line up the colored marker on the mirror cell with the colored marker inside the optical tube. Slide the complete mirror cell into

the rear of the telescope and secure the cell to the tube with the supplied hardware. Replace the end ring.

8. **Mounting the Optical Tube onto the Pier:** Place the fully assembled optical tube onto the saddle plate (26, Fig. 1) as shown and tighten the mounting straps around the tube with the knurled thumb nuts (9, Fig. 1). The telescope is now ready for final adjustments.

### BALANCING THE TELESCOPE

The telescope must be balanced around both axes in order for the mount to track accurately, keeping an object within the telescope's field of view. Most tracking errors are the result of improper balancing. With an improperly balanced telescope objects may become difficult to find or, once found, may be easily lost. To balance the telescope:

1. Loosen the Declination lock knob (24, Fig. 1).
2. Rotate the telescope about both axes so that the Declination shaft (20, Fig. 1) and the optical tube (4, Fig. 1) are both horizontal in relationship to the ground.
3. Slide the counterweight(s) along the Declination shaft, as necessary, until the telescope is balanced about the Polar axis. Lock the counterweight(s) and make certain that the counterweight safety washer (19, Fig. 1) is firmly in place.
4. Loosen the mounting straps (3, Fig. 1) just enough to allow the optical tube to slide within the straps.
5. Slide the tube back and forth within the straps until the telescope is in balance about the Declination axis. Tighten the knurled thumb nuts (9, Fig. 1) located at the ends of the two straps.
6. Re-tighten the Declination lock knob. With the telescope properly balanced, you should be able to place the optical tube in any position without drifting. Rebalancing may be necessary with the addition of any optional accessories.
7. Small scribe marks may be placed on the Declination shaft and optical tube to indicate the correct balancing positions. Such scribing will be an advantage if the telescope is to be frequently disassembled or transported.
8. For best performance, adjust the motor drive clutch pressure plate (see **Telescope Tracking**, page 13).

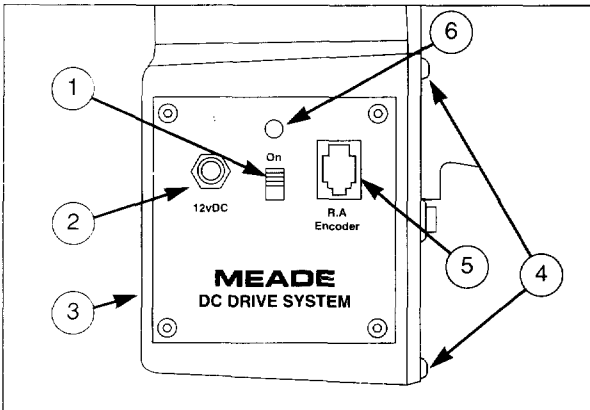

**Fig. 3:** Control Panel. (1) On/Off Switch; (2) 12vDC Outlet; (3) Battery Compartment (on side); (4) Dust Cover Attachment Screws; (5) R.A. Encoder Plug; (6) LED Power Indicator.

### CONTROL PANEL

**R.A. Encoder Plug** (5, Fig. 3): Used if the Magellan I Computer System is purchased for your Meade Starfinder. Details of how this additional encoder plug is used can be found in the Magellan I instruction manual. The Magellan II system requires a hardware upgrade and different control panel that will be sent with the Magellan II Hand Controller.

**On/Off Switch** (1, Fig. 3): Activates the DC motor drive system (see **The Motor Drive**, page 8). When the switch is ON a red LED (6, Fig. 3) illuminates. When the red LED on the panel shines steadily, the system is working properly and the battery is sufficiently charged. When the LED begins to blink, this indicates the internal battery pack is losing its charge and will soon need to be replaced.

The DC drive system on your Starfinder telescope can be operated from either an internal battery pack, requiring six (user supplied) AA size batteries, or an external 12 volt source (such as a car battery).

**Installing the batteries:** Open the battery compartment located on the side of the control panel (3, Fig. 3) and remove the battery carrier. The battery carrier holds six AA-size batteries and is connected to the telescope with a snap cable. Insert the batteries as indicated on the diagram on the battery slots. Slide the battery pack back into the battery compartment and close the lid.

**12vDC Outlet** (2, Fig. 3): Accepts a #607 Power Cord (See **OPTIONAL ACCESSORIES**, page 10) for powering the Starfinder Equatorial Telescope from a 12vDC automobile cigarette lighter plug. While the recommended supply voltage is 12vDC, the telescope will operate in a range of 6-18vDC.

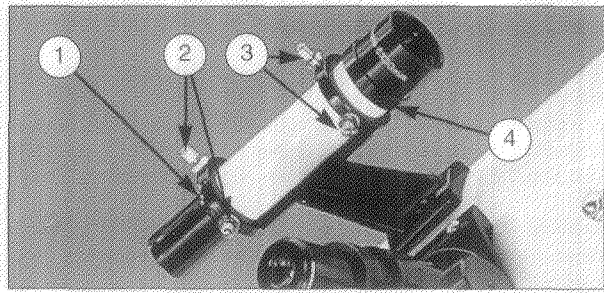

**Fig. 4:** 6 x 30mm Viewfinder. (1) Mounting Bracket; (2) Rear-most Alignment Screws; (3) Front-most Alignment Screws; (4) Viewfinder Focus Lock Ring.

### THE VIEWFINDER

The Starfinder telescope, as with almost all astronomical telescopes, presents a fairly narrow field of view to the observer. As a result, it is sometimes difficult to locate and center objects in the telescope's field of view.

The viewfinder, by contrast, is a low-powered, wide-field sighting scope with crosshairs that enables the easy centering of objects in the main telescope's field of view. Standard equipment with the Starfinder telescope is a viewfinder of 6-power and 30 mm aperture, called a "6 x 30mm viewfinder."

### Focusing the Viewfinder

The viewfinder has been factory prefocused to objects located at infinity. Individual eye variations, however, may require that the viewfinder be refocused to your eye. Looking through the viewfinder, point the telescope at a distant object; if the viewfinder image is not sufficiently in focus for your eye, it may be refocused as follows:

1. Remove the viewfinder from its mounting bracket (1 Fig. 4) by slightly unthreading the six alignment screws until the viewfinder can slip out easily.
2. Loosen the viewfinder focus lock ring (4, Fig. 4) at the objective-lens-end of the viewfinder, enabling rotation of the objective lens cell clockwise or counterclockwise for precise focusing while looking at a distant object through the viewfinder.
3. After a precise focus has been achieved, tighten the viewfinder focus lock ring against the objective lens cell to lock the focus in place.

- Replace the viewfinder into its bracket on the main telescope.

*NOTE: No focusing is possible from the eyepiece end of the viewfinder.*

### Aligning the Viewfinder

In order for the viewfinder to be useful, it must first be aligned with the main telescope, so that both the viewfinder and the main telescope are pointing at precisely the same place. To align the viewfinder, follow this procedure:

- The viewfinder bracket (1, Fig. 4) includes six alignment screws. Turn the three rear-most alignment screws (2, Fig. 4) so that the viewfinder tube is roughly centered within the viewfinder bracket, as viewed from the eyepiece-end of the telescope.
- Using the standard equipment 25mm eyepiece, point the main telescope at some easy-to-find, well-defined land object, such as the top of a telephone pole. Center the object precisely in the main telescope's field.
- While looking through the viewfinder, gently turn one or more of the three front-most viewfinder alignment screws (3, Fig. 4) until the crosshairs of the viewfinder point at precisely the same position as the main telescope. During this procedure, occasionally look through the main telescope to make sure the object is still centered.

When the object is centered in the viewfinder, confirm that the viewfinder's crosshairs and the main telescope are now pointing at precisely the same object. The viewfinder is now aligned to the main telescope. Unless the alignment screws are disturbed, the viewfinder will remain aligned indefinitely.

### Using the Viewfinder

Now, to locate any object, terrestrial or astronomical, first center the object on the crosshairs of the viewfinder; the object will then be centered in the field of the main telescope.

Note: If you intend to use higher observing magnifications, first locate, center, and focus the object using a low-power eyepiece (e.g., the 25mm eyepiece). Objects are easier to locate and center at low powers; higher power eyepieces may then be employed by changing eyepieces.

## MAGNIFICATION

The magnification, or power, at which a telescope is operating is determined by two factors: the focal length of the eyepiece employed and the focal length of the telescope. The Meade Starfinder telescope is supplied with one eyepiece as standard equipment. The focal length of the eyepiece, 25mm, is printed on its side.

Telescope focal length is, roughly speaking, the distance that light travels inside the telescope before reaching a focus.

The focal length of the Starfinder 6" f/8 = 1220mm.

The focal length of the Starfinder 8" f/6 = 1220mm.

The focal length of the Starfinder 10" f/4.5 = 1140mm.

On a given telescope, such as the Starfinder, different eyepiece focal lengths are used to achieve different magnifications, from low to high. Optional eyepieces and the #140 2x Barlow Lens are available for powers from 36x to over 500x (see **OPTIONAL ACCESSORIES**, page 10).

To calculate the magnification obtained with a given eyepiece, use this formula:

$$\text{Power} = \frac{\text{Telescope Focal Length}}{\text{Eyepiece Focal Length}}$$

Example: Using the 25mm eyepiece supplied with the 8" f/6, the power is:

$$\text{Power} = \frac{1220\text{mm}}{25\text{mm}} = 49\text{x}$$

The most common mistake of the beginning observer is to "overpower" the telescope and use high magnification which the telescope's aperture and typical atmospheric conditions cannot reasonably support. Keep in mind that a smaller, but bright and well-resolved, image is far superior to a larger, but dim and poorly resolved, one. Powers above about 300x should be employed with the Starfinder telescope only under the steadiest atmospheric conditions.

Most observers will want to have 3 or 4 eyepieces and perhaps the #140 2x Barlow Lens to achieve the full range of reasonable magnifications (see **OPTIONAL ACCESSORIES**, page 10).

## ASTRONOMICAL OBSERVING

The Starfinder telescope is an excellent observing tool for the serious amateur astronomer. The range of observable astronomical objects is, with minor qualification, limited only by the observer's motivation.

This section provides a basic introduction to the terminology associated with astronomy, and includes instructions for finding, following and photographing celestial objects.

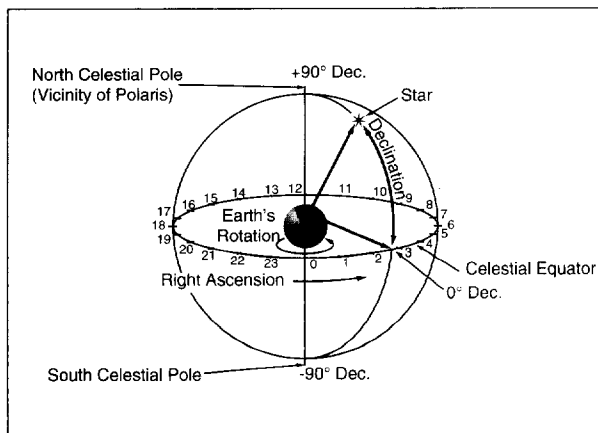

Fig. 5: The Celestial Sphere.

### Celestial Coordinates

Celestial objects are mapped according to a coordinate system on the Celestial Sphere, the imaginary sphere on which all stars appear to be placed. This celestial object mapping system is analogous to the Earth-based coordinate system of latitude and longitude.

The poles of the celestial coordinate system are defined as those two points where the Earth's rotational axis, if extended to infinity, north and south, intersect the celestial sphere (Fig. 5). Thus, the North Celestial Pole is that point in the sky where an extension of the Earth's axis through the North Pole intersects the celestial sphere. This point in the sky is located near the North Star, Polaris.

In mapping the surface of the Earth, lines of longitude are drawn between the North and South Poles. Similarly, lines of latitude are drawn in an east-west direction, parallel to the Earth's Equator. The Celestial Equator is a projection of the Earth's Equator onto the celestial sphere.

Just as on the surface of the Earth, in mapping the celestial sphere imaginary lines have been drawn to form a coordinate grid. Thus, celestial object positions on the Earth's surface are specified by their latitude and longitude. For example, you could locate Los Angeles, California, by its latitude (34°) and longitude (118°); similarly, you could locate the constellation

Ursa Major by its position on the celestial sphere:

R.A.: 11hr; Dec: +50° .

The celestial analog to Earth latitude is called Declination, or "Dec", and is measured in degrees, minutes and seconds (e.g., 15° 27' 33"). Declination shown as north of the celestial equator is indicated with a "+" sign in front of the measurement (e.g., the Declination of the North Celestial Pole is +90 °), with Declination shown as south of the celestial equator indicated with a "-" sign (e.g., the Declination of the South Celestial Pole is -90°). Any point on the celestial equator itself (which, for example, passes through the constellations Orion, Virgo and Aquarius) is specified as having a Declination of zero, shown as 0° 0' 0".

The celestial analog to Earth longitude is called "Right Ascension", or "R.A.", and is measured in time on the 24 hour 'clock' and shown in hours ("hr"), minutes ("min") and seconds ("sec") from an arbitrarily defined "zero" line of Right Ascension passing through the constellation Pegasus. Right Ascension coordinates range from 0<sup>hr</sup> 0<sup>min</sup> 0<sup>sec</sup> to 23<sup>hr</sup> 59<sup>min</sup> 59<sup>sec</sup>. Thus there are 24 primary lines of R.A., located at 15 degree intervals along the celestial equator. Objects located further and further east of the prime Right Ascension grid line (0<sup>hr</sup> 0<sup>min</sup> 0<sup>sec</sup>) carry increasing R.A. coordinates.

All celestial objects are specified in position by their celestial coordinates of Right Ascension and Declination. The telescope's Dec and R.A. setting circles (22 and 25, Fig. 1) may be dialed to the coordinates of a specific celestial object, which may then be located without a visual search. However, before you can make use of the telescope's setting circles to locate celestial objects, your telescope must first be polar aligned.

### Polar Alignment

By polar aligning the telescope, two important telescope capabilities are enabled: (a) the motor drive permits the telescope to track any astronomical object, automatically; (b) the telescope's Dec and R.A. setting circles, discussed above, may be used to locate faint celestial objects directly from their catalogued coordinates.

Celestial objects are essentially fixed on the celestial sphere; however, they appear to move across the sky in an arc as the Earth rotates on its axis, with a complete rotation of the Earth

occurring once in every 24 hour period. This apparent motion is not obvious to the unaided eye, but viewed through a telescope such as the Starfinder, this motion is rapid indeed. Objects centered in the telescope move entirely out of the field of view in 15 to 60 seconds, depending upon the magnification employed.

During the 24 hour period of the Earth's rotation, stars make one complete revolution about the Celestial Pole, making concentric circles with the Celestial Pole at the center. By lining up the telescope's polar axis with the North Celestial Pole (or South Celestial Pole if you are observing from the Earth's Southern Hemisphere), celestial objects may be followed (tracked) by moving the telescope about one axis, the polar axis.

Polar alignment consists of the following two operations:

1. Setting the telescope's latitude angle so that the latitude scale reads the latitude of your observing location (see **Adjusting the Latitude**, page 4).
2. Aligning the telescope with the celestial pole:
  - a. Identify the tripod leg designated as the "North-Pointing Leg" (2, Fig. 6) (the leg that is parallel to the Polar casting when viewed from above).
  - b. Set the mount on level ground with this leg pointing North.

Locating due-north by using Polaris, the North Star, is adequate for the purposes discussed here. Polaris can be found in relation to the Big Dipper by projecting a line from the so-called "pointer stars" of the Big Dipper, as shown in Fig. 7.

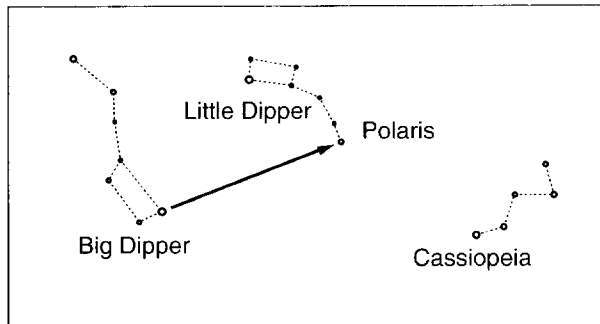

Fig. 7: Locating Polaris.

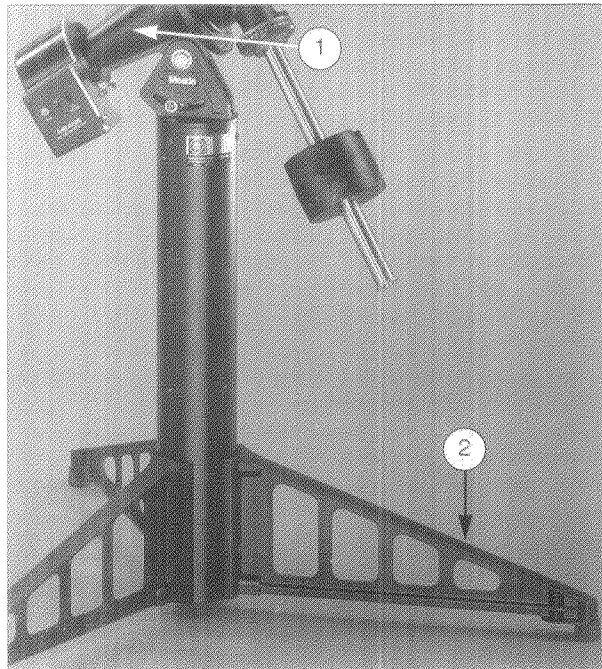

Fig. 6: Aligning the Telescope With the Celestial Pole. (1) Polar Axis, (2) North-Pointing Leg.

With these two steps accomplished, the telescope is sufficiently polar aligned for all visual observing purposes, as well as for photography of the Moon and planets.

*Note: Once the latitude angle of the pier has been set, you will not need to adjust the latitude angle again unless you move to a new observing site that is a considerable distance in latitude away from your original observing site; 70 miles of movement north or south is equivalent to only one degree in latitude change.*

Calibrating the Declination Circle: After your have polar aligned your telescope for the first time, take a moment to check the calibration of the Declination setting circle (2, Fig. 8) using the following steps:

1. Center Polaris in the telescope's field of view.
2. Use the hex wrench provided to loosen the Dec setting circle. With your finger, turn the setting circle until the dial reads 89.2° — the Declination of Polaris; then re-tighten the hex screw without moving the circle. The Declination setting circles are now calibrated.

## How to Locate Objects in the Night Sky

Now that your telescope is fully assembled and polar aligned, you are ready to begin observations.

Note that although the above assembly and polar alignment procedures may seem quite tedious — particularly if the Starfinder is your first serious telescope — in fact, assembly and polar alignment will quickly become routine. Once set, the latitude angle of the pier need never be changed, unless you move your observing site a considerable distance in latitude, perhaps 150 miles or more.

For the beginning amateur astronomer, the simplest method of locating objects in the night sky — and an excellent way to learn how to operate your telescope — is to look at a celestial object that can be clearly seen with your own eyes.

Find the desired object in the viewfinder, center the object in the viewfinder's crosshairs, then observe through the main telescope's eyepiece and adjust the focus knob until the image is clear and sharp. With the motor drive turned on, observe how the telescope tracks, or follows, the object as it arcs across the sky. Turn the motor drive off for a few seconds, and note how rapidly the objects move through the field of view.

The position of celestial objects changes over the course of the year, so you should obtain a star chart — such as the Meade Star Charts, available from your Meade dealer — or refer to the monthly star charts presented in astronomy magazines, such as *Sky & Telescope* and *Astronomy*.

With these aids and with a little experience at the controls of the Starfinder, you will soon be exploring the surface of the Moon, the planets of our Solar System and the incredible assortment of star clusters, galaxies, and nebulae that lie beyond.

## The Motor Drive

The DC drive system on your Starfinder telescope can be operated from either an internal battery pack or an external 12 volt source (such as a car battery). To use the motor drive, follow this procedure:

1. With the telescope polar aligned as described above, turn the motor drive on with the switch (1, Fig. 3) located on the Control Panel.
2. After switching the motor drive on, allow one minute for the drive to take up any internal gear-backlash.
3. Now, as you move the telescope from object to object, the motor drive will automatically track, or follow, the object, fully compensating for the effects of the Earth's rotation.

*Southern Hemisphere Operations.* Tracking is normally in a westerly direction (for the northern hemisphere) but can be changed by installing the southern hemisphere jumper as follows:

1. Remove the five Phillips head screws that hold the dust cover to the polar housing plate (4, Fig. 3).
2. Behind the dust cover, you will see the circuit board with two "L"-shaped prongs extending from the board. One prong should have the jumper (a small, plastic, black square with two openings, side by side) attached.
3. Remove the jumper from one prong and slide it onto both prongs. The telescope will now track in an easterly direction.
4. To return the telescope to northern hemisphere operations, simply pull the jumper off both prongs and store it on one of the prongs.

## Setting Circles

Setting circles included with the Starfinder permit the location of faint celestial objects not easily found by direct visual observation. The R.A. circle (1, Fig. 8) is located at the end of the polar casting, opposite the Control Panel. The Declination

circle (2, Fig. 8) is located at the end of the Declination Casting, just before the counterweight shaft. With the telescope pointed at the North Celestial Pole, the Dec circle should read 90° (understood to mean +90°). Objects located below the 0-0 line of the Dec circle carry minus Declination coordinates. Each division of the Dec circle represents a 1° increment. The R.A. circle runs from 0<sup>hr</sup> to (but not including) 24<sup>hr</sup>, and reads in increments of 5<sup>min</sup>.

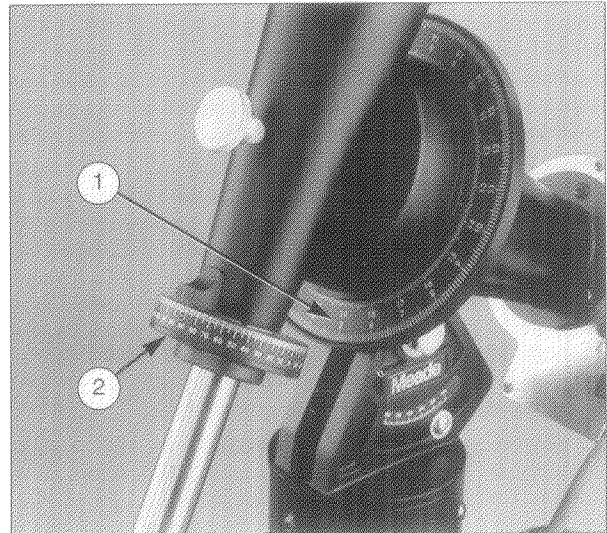

**Fig. 8:** Setting Circles. (1) R.A. Setting Circle; (2) Declination Setting Circle.

Note that the R.A. circle is double-indexed; *i.e.*, there are two series of numbers running in opposite directions around the circumference of the R.A. circle. The outer series of numbers (increasing counterclockwise) applies to observers located in the Earth's Northern Hemisphere; the inner series of numbers (increasing clockwise) applies to observers located in the Earth's Southern Hemisphere.

To use the setting circles to locate an object not easily found by direct visual observation:

With the telescope aligned to the pole, center an object of known R.A. in the telescopic field. Then turn the R.A. circle, which can be rotated manually, until the R.A. coordinate of the object is correctly indicated by the R.A. pointer. As long as the telescope's motor drive remains "ON," the R.A. pointer will then correctly indicate the R.A. of any object at which the telescope is pointed throughout the duration of the observing session.

To locate a particular object, first look up the celestial coordinates (R.A. and Dec) of the object in a star atlas. Then, turn the telescope to read the correct R.A. of the desired object. Turn the telescope in Declination to read the correct Declination of the object. If the procedure has been followed carefully, and if the telescope was well-aligned with the pole, the desired object should now be in the telescopic field of a low-power eyepiece.

If you do not immediately see the object you are seeking, try searching the adjacent sky area using the viewfinder. Because of its much wider field, the viewfinder may be of significant assistance in locating and centering objects, after the setting circles have been used to locate the approximate position of the object.

Pinpoint application of the setting circles requires that the telescope be precisely aligned with the pole.

The setting circles may also be utilized in the absence of a power source for the motor drive. In this case, however, it is necessary to manually reset to the R.A. of the object you are observing just before going to the next object.



### Observing Tips

To enjoy your Starfinder telescope to the fullest, follow these recommendations:

1. Let the telescope "cool down" to the outside temperature before attempting to make serious observations. After removing the telescope from a warm house, the telescope's optics need about 15 to 20 minutes to adjust to the outside temperature before they will perform well.
2. Avoid setting up the telescope inside a room and observing through an open window (or, worse, a closed window!). In such a case air currents caused by differences in indoor/outdoor temperatures make quality astronomical optical performance impossible.

*Note:* A practical exception to the above rule is the case where the Starfinder is, for example, set up in a living room or den for observing an outdoor terrestrial scene or view through a closed window. At low powers (up to about 60X) the telescope will perform reasonably well in this application, but the observer should understand clearly that optical performance under these conditions can not approach the performance that will be realized if the telescope were instead set up outside.

3. As discussed above, avoid "overpowering" your telescope. If the terrestrial or astronomical image becomes fuzzy at high powers, drop down to a lower power. Image degradation at high powers is not due to any fault of the telescope but is caused by heat waves and turbulence in the Earth's atmosphere. Astronomical observations at high powers (i.e., above about 200X) should be undertaken only when the atmosphere is very steady, as confirmed by an absence of "twinkling" in star images.
4. Try not to touch the eyepiece when observing through the telescope. Vibrations in your hand are immediately transferred to the telescopic image.
5. If you wear eyeglasses and do not suffer from astigmatism, take your glasses off when using the telescope; the telescope's magnification compensates for near- or farsightedness. Observers with astigmatism should, however, wear their glasses, since the telescope can not compensate for this eye defect.
6. Allow your eyes to become "dark adapted" before attempting serious astronomical observations through the telescope. Night adaptation normally requires about 10 to 15 minutes.
7. As you use your Starfinder more and more for astronomical observing, you will find that you are seeing finer and finer detail — on the surface of Jupiter, for example. Observing through a fine optical instrument is to some degree an acquired skill. Celestial observing becomes increasingly rewarding as your eye becomes better trained in the detection of subtle variations of color, contrast, and resolution.

### ASTROPHOTOGRAPHY

Your reflecting telescope can be used as a powerful astrophotographic lens with the addition of virtually any 35mm Single Lens Reflex (SLR) camera body. The Basic Camera Adapter (available optionally; see the Meade General Catalog) and T-Mount for your specific brand of SLR camera serve as the link between telescope and camera.

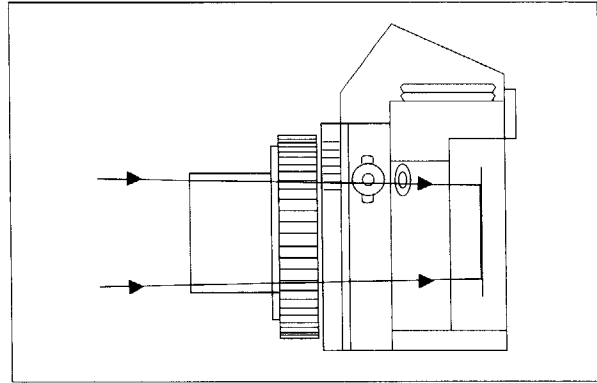

Fig. 9: Prime-Focus Photography.

The Starfinder Equatorial Telescope design allows the user to take short exposure photographs of the Moon and planets using either prime-focus or eyepiece projection photographic techniques. Designed without slow-motion controls, the Starfinder is not capable of taking the long exposures required for deep-sky astrophotography. However, with the purchase of the optional Magellan II Computer Correction System (see **OPTIONAL ACCESSORIES**, page 11), which includes dual-axis drive correction capabilities, the ability to guide for longer exposures is much improved.

To mount your camera on the telescope:

1. Remove the standard lens from your camera and set it aside. (Remember: the telescope is the camera's lens.)
2. Attach the appropriate T-Mount to your 35mm SLR camera.
3. Thread the prime-focus section of the Basic Camera Adapter (optional) into the front of the T-Mount now attached to your camera (Fig. 9).

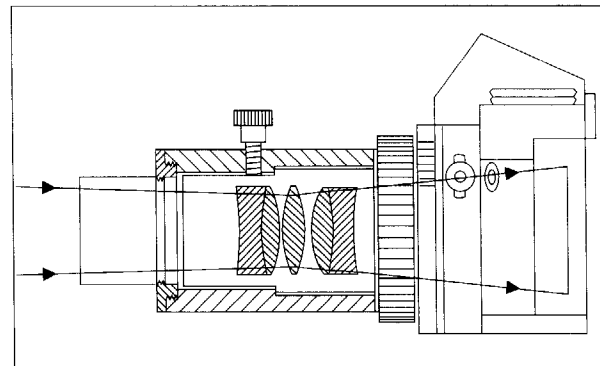

Fig. 10: Eyepiece-Projection Photography.

4. Remove the eyepiece from the focuser and insert the chrome barrel of the camera adapter into the focuser drawtube. (Re-balancing may be necessary.)
5. Focus the camera by looking through the camera viewfinder and turning the telescope's focuser knobs until the image is sharp.

In the above configuration, the telescope is operating in the "prime-focus" or no-eyepiece photographic mode. The resulting magnification is 25X on the 6" and 8" models and 22X on the 10" model. In the prime focus mode, the primary mirror must

first be moved forward to the second set of mounting holes (5, Fig. 1). The low magnification yielded in this mode is ideal for wide-angle photography of the Moon, galaxies, nebulae, and star clusters.

When higher magnification is desired, such as during lunar and planetary photography, an eyepiece may be inserted into the Camera Adapter (Fig. 10) so that the image is projected through the eyepiece, onto the film plane. This is known as Eyepiece-Projection photography, and requires the primary mirror be placed in the second set of mounting holes.

A few tips on astrophotography:

1. The telescope must be polar aligned, as discussed above.
2. The mount must be on a solid level surface.
3. Use a cable-operated shutter release. Touching the camera body to initiate shutter operations will almost certainly introduce undesirable vibrations.
4. Use "fast" films (high ASA ratings) to reduce exposure times.
5. Focus the image with extreme care. While observing the celestial object through the camera's viewfinder, turn the Starfinder's focus knob to achieve the sharpest possible focus.
6. Hold a piece of cardboard over the front of the telescope until the shutter has been locked open and all vibrations have had time to dampen out.
7. Bracket exposure times widely. Correct shutter speeds vary widely, depending on lighting conditions and the film used. Trial-and-error is the best way to determine the proper shutter speed in any given application.
8. Terrestrial photography through a telescope is sensitive to heat waves rising from the Earth's surface. Long distance photography is best accomplished in the early morning hours, before the earth has had time to build up heat.
9. NEVER attempt to photograph (or observe) the Sun.
10. Astrophotography is an acquired skill; exercise patience and expect to waste a few rolls of film as you learn the techniques. The rewards of taking a quality astrophotograph, however, will make all your efforts worthwhile.

## OPTIONAL ACCESSORIES

A wide assortment of professional Meade accessories is available for the Starfinder telescopes.

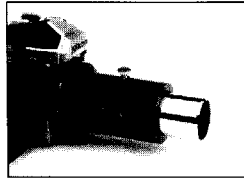

**Basic Camera Adapter:** A Basic Camera Adapter is necessary for photography through a Starfinder Equatorial. An eyepiece can be inserted into the adapter and an enlarged image is projected onto the camera film plane.

**Dust Covers:** Snug-fitting vinyl dust covers protect optics from outside dust during storage of the telescope.

**Eyepieces:** Many additional eyepieces are available for higher and lower magnifications. All Meade Starfinder Equatorial telescopes accept standard 1.25" O.D. eyepieces as well as 2" O.D. eyepieces.

Meade Super Plössl (SP), Super Wide Angle (SWA), and Ultra Wide Angle (UWA) Eyepieces in the standard American-size (1.25") barrel diameter (Fig. 9) or the 2" barrel size permit a wide range of magnifying powers with the telescope. Powers obtained with each eyepiece are as follows:

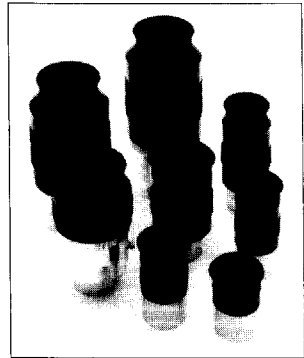
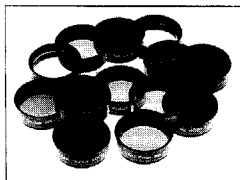

Fig. 11: Series 4000 eyepieces.

<i>Eyepiece</i>	<i>6" f/8 Power</i>	<i>8" f/6 Power</i>	<i>10" f/4.5 Power</i>
SP 6.4mm	191X	191X	178X
SP 9.7mm	126X	126X	118X
SP 12.4mm	98X	98X	92X
SP 15mm	81X	81X	76X
SP 20mm	61X	61X	57X
SP 26mm	47X	47X	44X
SP 32mm	38X	38X	36X
SP 40mm	31X	31X	*
SWA 13.8mm	88X	88X	83X
SWA 18mm	68X	68X	63X
SWA 24.5mm	50X	50X	47X
SWA 32mm	38X	38X	36X
SWA 40mm	31X	31X	*
UWA 4.7mm	260X**	260X**	243X
UWA 6.7mm	182X	182X	170X
UWA 8.8mm	139X	139X	130X
UWA 14mm	87X	87X	81X

\* Not recommended for 10" models.  
\*\* Should be used only under extremely steady atmospheric conditions.

Meade Super Plössl and Super Wide Angle Eyepieces are ideal for general-purpose astronomical or terrestrial observing. The typical Starfinder user may wish to add 2 or 3 of these eyepieces to his or her telescope. An introductory selection might include the SP 9.7mm and SP 15mm. The more advanced observer will perhaps select the SP 9.7mm, SP 12.4mm, and SWA 18mm. The Super Wide Angle Eyepiece series yields extremely wide fields of view, perfect for the examination of star fields, diffuse nebulae, or for terrestrial applications. Under very steady seeing conditions Meade UWA 4.7mm and 6.7mm eyepieces present the widest fields of view obtainable at high powers and are excellent eyepieces for the Moon and planets.



**Filters:** Thirteen color filters are available for significantly increased contrast and resolution of detail on the Moon and planets. For example, the #80A (blue) filter effectively enhances the reddish-colored detail on the surface of

Jupiter. These filters thread into the barrels of all standard 1.25" O.D. eyepieces and may also be used for eyepiece projection photography.

**Illuminated Reticle Eyepiece:** Permits easy visibility of guiding crosslines even against the darkest skies. The standard #702A double-crossline, phosphorescent-enhanced reticle allows for variable illumination from faint to very bright.

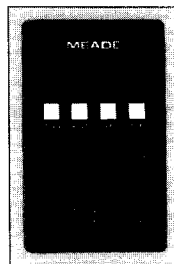
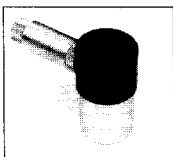

**Magellan I:** The Magellan I accessory will permit you to add a powerful pointing tool to your Starfinder telescope. Encoders supplied with this product for the R.A. and Dec. axis can be easily installed in factory machined mounting features. Once installed, the Magellan I will allow the electronic selection and pointing of the telescope at a large number of catalogued objects in the sky.

**Magellan II and Dual-Axis Drive Correction:** The Magellan II offers all of the pointing features of the Magellan I with the addition of dual-axis drive correction. Along with the high resolution encoders a Dec. motor drive system is included. The hand held Magellan II has pushbuttons to allow drive correction on both the R.A. and Dec. axis. The Magellan II will allow the electronic



selection and pointing of the telescope at a large number of catalogued objects in the sky.

**#55 Manual Declination Control:** Attaches directly to the equatorial mount, this Manual Declination Control allows the user to make fine micrometric adjustments in Declination.



**#140 2x Barlow Lens:** The Barlow Lens, or Telenegative Amplifier, is a convenient accessory used to increase the effective magnification of any given eyepiece. The Barlow Lens is inserted into the focuser and accepts all standard 1.25" O.D. eyepieces.

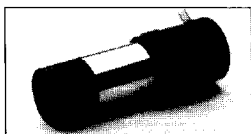

**#607 Power Cord:** This 25 ft. power cord allows the user to power the Starfinder Equatorial Telescope from an 12vDC automobile cigarette lighter plug.



**Viewfinders:** In addition to the standard-equipment 6x30mm viewfinder supplied with all Starfinder telescopes, the higher power/larger aperture 8x50mm viewfinder is available to substitute or retrofit.

## MAINTENANCE AND SERVICING

### Care Of Optics And Main Tube

With the reasonable care due any fine instrument, your Meade telescope will last a lifetime. If the eyepieces become dirty, try cleaning them with a camel's hair brush or compressed air. If you must wipe the surface of the lenses, do so gently with a soft cloth so as not to scratch the protective coatings.

The aluminum coating on the primary and secondary mirrors may last more than ten years without significant deterioration. (The coatings will last a shorter period if regularly exposed to salty or polluted air.) Minor blemishes, scratches, or streaks will NOT impair the telescope's performance. Re-coating, when necessary, is relatively inexpensive. Contact your local Meade dealer for information on mirror re-coating services.

#### 1. Cleaning the Optics

The most common error is to clean the optics too often. If it does become necessary, clean as follows:

- Remove the mirror from its cell.
- With the mirror resting face up on a towel, run a continuous stream of cold water onto its surface.
- Dip a wad of cotton in a mild liquid detergent solution (1/2 teaspoon to 1 pint of water) and gently swab the entire surface.
- Continue running water on the mirror surface to prevent beading and make ready three wads of cotton and a solution of 50% distilled water and 50% isopropyl alcohol.
- Dip a cotton wad into the alcohol solution and, ONLY NOW, turn off the water.
- Swab the entire surface. Do not turn over the cotton wads or dissolved skin oils may deposit on the mirror's surface. Immediately take a dry swab and continue wiping the entire surface gently. Keep changing wads until the mirror surface is completely dry and free of streaks.

#### 2. Cleaning the Optical Tube

When cleaning the outside of the Starfinder optical tube (4, Fig. 1), use a mild detergent. Oil soap is preferred as it also acts as a preservative for the paint. Solvent or alcohol based cleaning solutions will diminish the original luster of the paint.

### Collimation Of The Optical System

All Meade Starfinder Reflecting telescopes are optically aligned at the factory prior to shipment. It is unlikely that you will need to align, or collimate, the optics when you receive the instrument. However, if the telescope received unusually rough handling in shipment, it is possible that the optics must be re-aligned to obtain the best optical performance. In any case, this alignment procedure is simple, and requires only a few minutes the very first time the telescope is used. Take the time to familiarize yourself with the following collimation procedure so that you will recognize a properly collimated instrument and can adjust the collimation yourself, if necessary.

#### 1. Correct Collimation

A properly collimated (aligned) mirror system in your Starfinder Reflecting telescope assures the sharpest images possible. Your Starfinder is properly aligned when the primary mirror (3, Fig. 12, and secondary mirror (2, Fig. 12) are tilted so that the focused image (6, Fig. 12) falls directly through the center of the focuser drawtube (5, Fig. 12).

To inspect the view of the mirror collimation, remove the eyepiece and look down the focuser drawtube. The round edge of the focuser drawtube (1, Fig. 14) will frame the reflections of the primary mirror with the secondary mirror (2, Fig. 1), the spider vanes (3), Fig. 14, and your eye (4, Fig. 14). Properly aligned, all of these reflections will appear concentric (*i.e.* centered) as illustrated in Fig. 14. Any deviation from the concentric reflections will require adjustments to the secondary mirror assembly (Fig. 13), and/or the primary mirror cell.

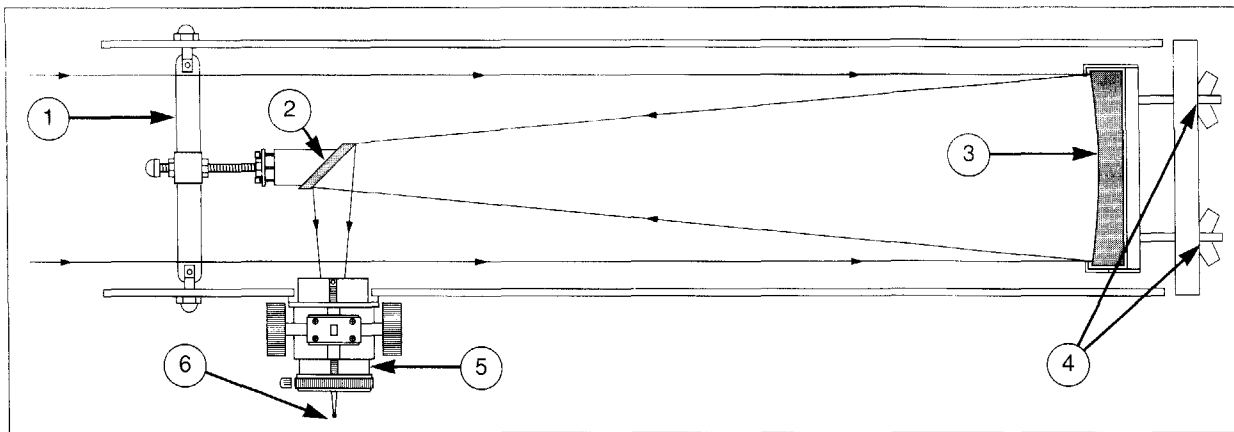

Fig. 12: Newtonian Reflecting Telescope. (1) Spider Vanes; (2) Secondary Mirror; (3) Parabolic Primary Mirror; (4) Primary Mirror Tilt Screws; (5) Focuser Drawtube; (6) Focused Image.

## 2. Spider Vane Adjustments

Looking down the open end of the telescope tube, check to see if the secondary mirror system is centered in the optical tube. If the assembly is off-center, loosen one of the spider vane adjustment/lock knobs while unscrewing the opposite knob. Only make adjustments to 2 knobs at a time until the secondary mirror is centered in the drawtube. When the spider vane is correctly positioned, the view through the drawtube will look like Fig. 16. (Note that the secondary mirror is misaligned.)

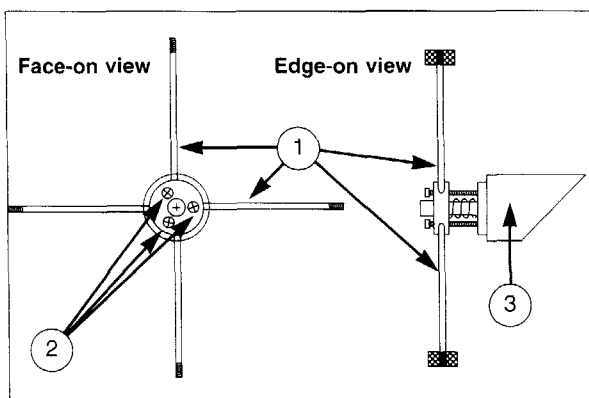

Fig. 13: Secondary Mirror Assembly. (1) Spider Vanes; (2) Tilt screws; (3) Secondary Mirror Holder.

## 3. Secondary Mirror Adjustments

If the secondary mirror (1), Fig. 16, is centered in the drawtube (2), Fig. 16, but the primary mirror is only partially visible in the reflection (3), Fig. 16, the 3 hex screws located on the secondary mirror assembly (2), Fig. 13, must be unthreaded slightly to refine the tilt-angle of the secondary mirror until the entire primary mirror can be seen centered within the secondary mirror reflection. When the secondary mirror is correctly aligned, it will look like Fig. 17. (Note that the primary mirror is misaligned.)

## 4. Primary Mirror Adjustments

If the secondary mirror and the reflection of the primary mirror (1), Fig. 17, appear centered within the drawtube (2), Fig. 17, but the reflection of your eye (3), Fig. 17, appears off-center, you will need to adjust one or more of the three primary mirror hex screws of the primary mirror cell. These primary hex screws are located behind the primary mirror, at the lower end of the main tube. Adjust the primary mirror alignment by slightly turning one hex screw at a time, looking through the focuser after each adjustment to determine if the mirror is moving in the correct direction.

## 5. Star Testing the Collimation

With the collimation performed, the next step is to test the accuracy of the alignment on a star. Use the 25mm eyepiece

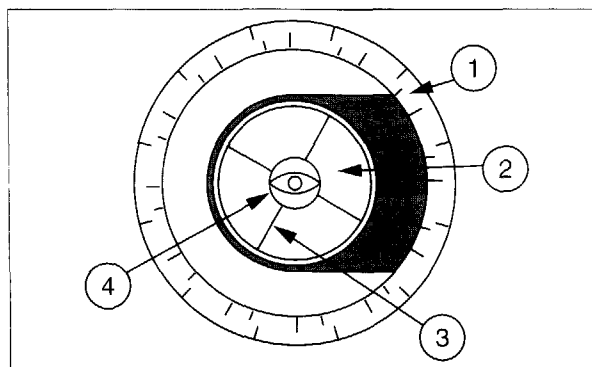

Fig. 14: Correct Collimation. (1) Round Edge of Focuser Drawtube; (2) Secondary Mirror; (3) Spider vanes; (4) Eye.

and point the telescope at a moderately bright (second or third

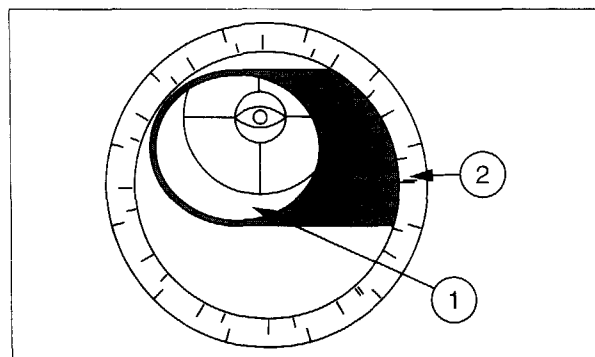

Fig. 15: Spider Vane Misalignment. (1) Secondary Mirror; (2) Round Edge of Focuser Drawtube.

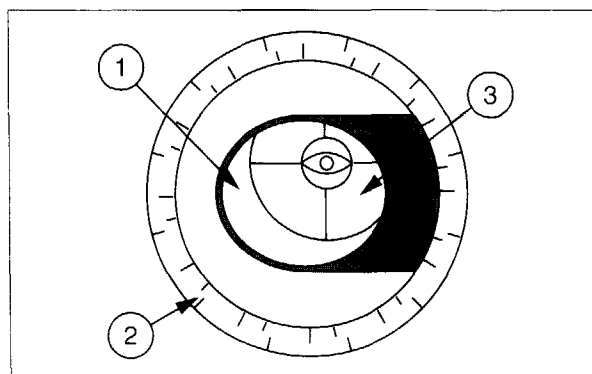
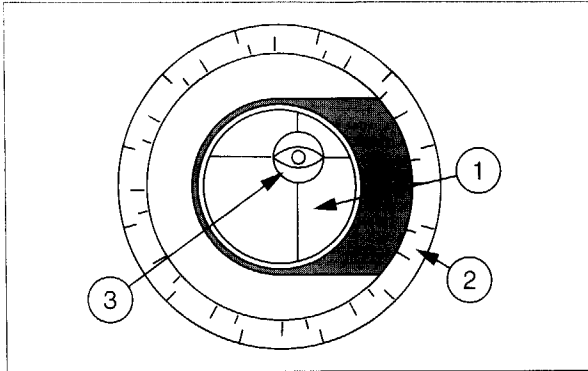

Fig. 16: Secondary Mirror Misalignment. (1) Secondary Mirror; (2) Round Edge of Focuser Drawtube; (3) Reflection of Primary Mirror.



**Fig. 17:** Primary Mirror Misalignment. (1) Secondary Mirror; (2) Round Edge of Focuser Drawtube; (3) Eye.

magnitude) star, then center the star image in the telescope's field-of-view. With the star centered, follow the method below:

- a. Bring the star image slowly out of focus until one or more rings are visible around the central disc. If the collimation was performed correctly, the central star disk and rings will be concentric circles, with a dark spot dead center within the out-of-focus star disk (this is the shadow of the secondary mirror), as shown in Fig. 18A. (An improperly aligned telescope will reveal elongated circles, Fig. 18B, with an off-center dark shadow.)
- b. If the out-of-focus star disk appears elongated (Fig. 18B), you will need to adjust the primary mirror tilt hex screws of the primary mirror cell. Adjust the hex screw on the mirror cell until the circles are concentric on either side of focus.

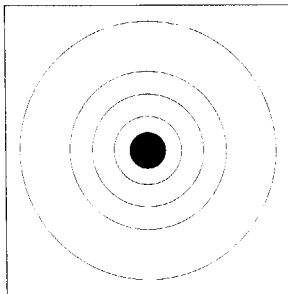

**Fig. 18A.**

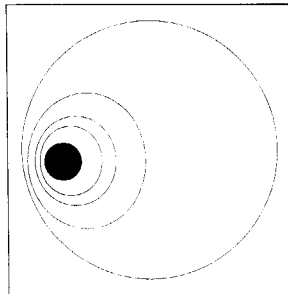
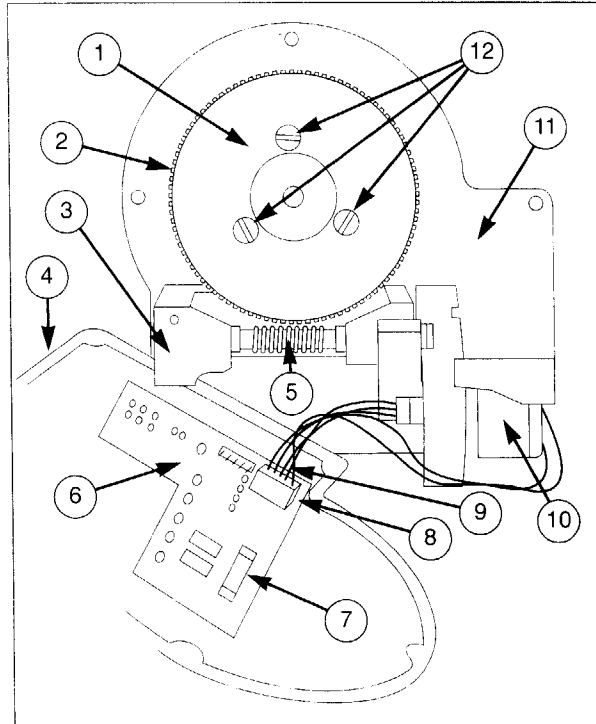

**Fig. 18B.**

### Telescope Tracking

If the telescope does not correctly track a star, check the telescope's polar alignment (see **Polar Alignment**, page 7). If a problem still persists, check the following:

1. **Power Supply:** The motor may not be getting power — check battery condition and replace if necessary.
2. **Slow Blow Fuse:** Your Starfinder is equipped with a slow-blow fuse that will sacrifice itself to prevent harm to your equipment. This fuse can be replaced by removing the dust cover to expose the fuse holder on the back of the control panel.
3. **Balance:** The telescope may not be properly balanced (see **BALANCING THE TELESCOPE**, page 5).
4. **Clutch Pressure Plate:** The clutch pressure plate may be loose. To tighten the pressure plate:
  - a. Remove the dust cover. You will see five wires coming off the motor. These wires all lead to one connector (8, Fig. 17) that plugs into the top corner of the circuit board, next to the fuse (7, Fig. 17). Unplug this connector (the motor plug) before you do any work on the motor.
  - b. Tighten each of the three clutch pressure plate screws (12, Fig. 17) slightly until there is sufficient



**Fig. 17:** The Motor Drive System. (1) Clutch pressure plate; (2) Worm gear; (3) Worm block; (4) Dust cover; (5) Worm; (6) Circuit board; (7) Slow-blow fuse; (8) Motor plug connector; (9) Red wire; (10) Synchronous motor; (11) Back plate; (12) Clutch adjustment screws.

drag to drive the telescope.

- c. Plug the connector (8, Fig. 17) back into the top corner of the circuit board, making sure that all 5 pins on the circuit board are covered by the connector. The connector should be oriented so that the wires are leading away from the board, not crossing over the board. Note the location of the red wire (9, Fig. 17). Replace the dust cover.
5. **Worm Block:** The worm block may be out of adjustment. To eliminate binding in the worm gear system:
  - a. Remove the dust cover and unplug the motor from the circuit board (as described above in Step 4a).
  - b. Loosen the two screws that hold the worm block (3, Fig. 17) to the back plate (11), Fig. 17.
  - c. Fit the worm (5, Fig. 17) snugly against the spur gear (2, Fig. 17) with just a small amount of play.
  - d. Tighten the worm block screws and connect the motor plug to the circuit board (as described above in Step 4c). Replace the dust cover.

### Meade Customer Service

If you have a question concerning your Meade Starfinder telescope, call Meade Instruments/Customer Service Dept. at 949-451-1450, or fax at 949-451-1460. Customer Service hours are 8:30AM - 4:00PM, Pacific Time, Monday through Friday. In the unlikely event that your Starfinder telescope requires factory servicing or repairs, write or call the Meade Customer Service Dept. first, before returning the telescope to the factory, giving full particulars as to the nature of the problem, as well as your name, address, and daytime telephone number. The great majority of Starfinder servicing issues can be resolved by telephone, avoiding return of the telescope to the factory.

## Appendix A: Specifications and Features: Meade Starfinder™ Reflecting Telescopes

TELESCOPE:	Starfinder Equatorial 6	Starfinder Equatorial 8	Starfinder Equatorial 10
<b>Optical Design</b>	Newtonian Reflector	Newtonian Reflector	Newtonian Reflector
<b>Diameter/Clear Aperture</b>	152mm (6")	203mm (8")	254mm (10")
<b>Primary &amp; Secondary Mirrors</b>	Grade-A Pyrex® glass, fine annealed	Grade-A Pyrex® glass, fine annealed	Grade-A Pyrex® glass, fine annealed
<b>Secondary Mirror Support</b>	4-vane; steel	4-vane; steel	4-vane; steel
<b>Focal Length</b>	1220mm	1220mm	1140mm
<b>Focal Ratio</b>	f/8	f/6	f/4.5
<b>Resolving Power (arc secs.)</b>	0.74	0.56	0.45
<b>Limiting Visual Magnitude</b>	13.5	14.0	14.5
<b>Limiting Photographic Magnitude</b>	16.0	16.5	17.0
<b>Image Scale</b>	1.18°/inch	1.18°/inch	1.26°/inch
<b>Maximum Practical Visual Power</b>	400X	500X	600X
<b>35mm Angular Film Coverage</b>	1.11° x 1.58°	1.11° x 1.58°	1.19° x 1.70°
<b>Optical Tube</b>	7.6" dia. x 48" long spiral-wound Sonotube	9.6" dia. x 48" long spiral-wound Sonotube	12.7" dia. x 45" long spiral-wound Sonotube
<b>Secondary Mirror Minor Axis</b>	1.18"	1.83"	2.37"
<b>Secondary Mirror Obstruction</b>	3.9%	3.6%	5.6%
<b>Equatorial Mounting</b>	German-type	German-type	German-type
<b>Polar and Dec Shaft Dias.</b>	1.0"	1.0"	1.0"
<b>Bearings</b>	Polar & Dec: Nylon	Polar & Dec: Nylon	Polar & Dec: Nylon
<b>Pier (dia. x height)</b>	4.0" x 24" steel	4.0" x 24" steel	4.0" x 24" steel
<b>Motor Drive System</b>	9-volts D.C.	9-volts D.C.	9-volts D.C.
<b>Drive Gear</b>	3" helical spur gear	3" helical spur gear	3" helical spur gear
<b>Setting Circle Dias.</b>	RA: 7"; Dec: 3"	RA: 7"; Dec: 3"	RA: 7"; Dec: 3"
<b>Latitude Range</b>	5° to 60°	5° to 60°	10° to 60°
<b>Material</b>	aluminum castings	aluminum castings	aluminum castings
<b>Total Net Telescope Weight (approx.)</b>	57 lbs.	69 lbs.	97 lbs.
<b>Heaviest Component for Field Assembly</b>	35 lbs.	35 lbs.	35 lbs.
<b>Shipping Weight (approx.)</b>	77 lbs.	84 lbs.	113 lbs.

### FCC NOTICE

This equipment has been tested and found to comply with the limits for a CLASS A digital device, pursuant to Part 15 of the FCC Rules. These limits are designed to provide reasonable protection against harmful interference when the equipment is operated in a commercial environment. This equipment generates, uses, and can radiate radio frequency energy and, if not installed and used in accordance with the instruction manual, may cause harmful interference to radio communications. Operation of this equipment in a residential area is likely to cause harmful interference in which case the user will be required to correct the interference at his own expense.



### MEADE LIMITED WARRANTY

Every Meade telescope, spotting scope, and telescope accessory is warranted by Meade Instruments Corporation ("Meade") to be free of defects in materials and workmanship for a period of ONE YEAR from the date of original purchase in the U.S.A. and Canada. Meade will repair or replace a product, or part thereof, found by Meade to be defective, provided the defective part is returned to Meade, freight-prepaid, with proof of purchase. This warranty applies to the original purchaser only and is non-transferable. Meade products purchased outside North America are not included in this warranty, but are covered under separate warranties issued by Meade international distributors.

**RGA Number Required:** Prior to the return of any product or part, a Return Goods Authorization (RGA) number **must** be obtained from Meade by writing, or by calling (949) 451-1450. Each returned part or product must include a written statement detailing the nature of the claimed defect, as well as the owner's name, address, and phone number.

This warranty is not valid in cases where the product has been abused or mishandled, where unauthorized repairs have been attempted or performed, or where depreciation of the product is due to normal wear-and-tear. Meade specifically disclaims special, indirect, or consequential damages or lost profit which may result from a breach of this warranty. Any implied warranties which can not be disclaimed are hereby limited to a term of one year from the date of original retail purchase.

This warranty gives you specific rights. You may have other rights which vary from state to state.

Meade reserves the right to change product specifications or to discontinue products without notice.

This warranty supersedes all previous Meade product warranties.





# Meade Instruments Corporation

*World's leading manufacturer of astronomical telescopes for the serious amateur.*

6001 Oak Canyon, Irvine, California 92620 ■ (949) 451-1450

Fax: (949) 451-1460 ■ [www.meade.com](http://www.meade.com)



## Free Manuals Download Website

<http://myh66.com>

<http://usermanuals.us>

<http://www.somanuals.com>

<http://www.4manuals.cc>

<http://www.manual-lib.com>

<http://www.404manual.com>

<http://www.luxmanual.com>

<http://aubethermostatmanual.com>

Golf course search by state

<http://golfingnear.com>

Email search by domain

<http://emailbydomain.com>

Auto manuals search

<http://auto.somanuals.com>

TV manuals search

<http://tv.somanuals.com>