

Miele

Operating and installation instructions



Frost free fridge freezer with dynamic cooling KFN 12943 SD edt/cs

To avoid the risk of accidents or damage to the appliance, it is **essential** to read these instructions before it is installed or used for the first time.

en - GB

M.-Nr. 09 290 880

Contents

Guide to the appliance	4
Caring for the environment	6
Warning and Safety instructions	7
How to save energy	12
Switching on and off	13
Protective foil	13
Cleaning and care	13
To switch the refrigerator section off separately	14
Switching off for longer periods of time	14
The correct temperature	15
. . . in the refrigerator section	15
. . . in the freezer section	15
Setting the temperature	15
Temperature display	16
Temperature range	16
Alarm	18
Temperature alarm	18
Door alarm	18
Super freeze and Dynamic cooling	19
Super freeze	19
Dynamic cooling 	20
Using the refrigerator efficiently	21
Different storage zones	21
Food which should not be stored in a refrigerator	22
When shopping for food	22
Storing food correctly	22
Fruit and vegetables	22
Unpacked meat and vegetables	23
Protein rich foods	23
Meat	23
Adjusting the interior fittings	24
Moving the shelves	24
Split shelf	24
Adjusting the condiment tray/bottle shelf	25
Universal container	25
Moving the bottle divider	25

Freezing and storing food	26
Maximum freezing capacity	26
Freezing fresh food	26
Storing frozen food	26
Home freezing	27
Hints on home freezing	27
Packaging	27
Before placing food in the freezer compartment	28
Placing food in the freezer section	28
Freezer calendar	29
Defrosting	29
Ice cubes	30
Cooling drinks	30
Automatic defrost	31
Cleaning and care	32
Cleaning the interior and accessories	33
Appliance doors, side panels	34
Ventilation gaps	35
Door seals	35
Metal grille at the back of the appliance	35
Problem solving guide	36
Noises	39
After Sales / Guarantee	40
Electrical connection	41
Installation	42
Location	42
Climate range	43
Ventilation	43
Installation	43
Aligning the appliance	43
Levelling the appliance door	43
Appliance dimensions	44
Changing the door hinging	45
Aligning the appliance doors	51
Building in the appliance	52

Guide to the appliance

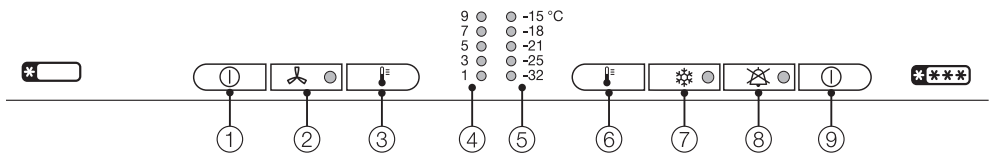

- ① On button for the whole appliance and On/Off button for independently switching the refrigerator section on and off
- ② Dynamic cooling button and indicator light
- ③ Refrigerator section temperature selector button
- ④ Refrigerator section temperature display
- ⑤ Freezer section temperature display
- ⑥ Freezer section temperature selector button
- ⑦ Super freeze button and indicator light
- ⑧ Alarm off button and indicator light
- ⑨ Master switch for switching the whole appliance on and off

Guide to the appliance

- ① Dynamic cooling fan
- ② Interior lighting
- ③ Butter and cheese compartment
- ④ Egg tray/Condiment tray
- ⑤ Adjustable shelf
- ⑥ Condensate channel and drain hole
- ⑦ Fruit and vegetable containers
- ⑧ Bottle holder
- ⑨ Bottle shelf
- ⑩ Freezer drawers with freezer calendar

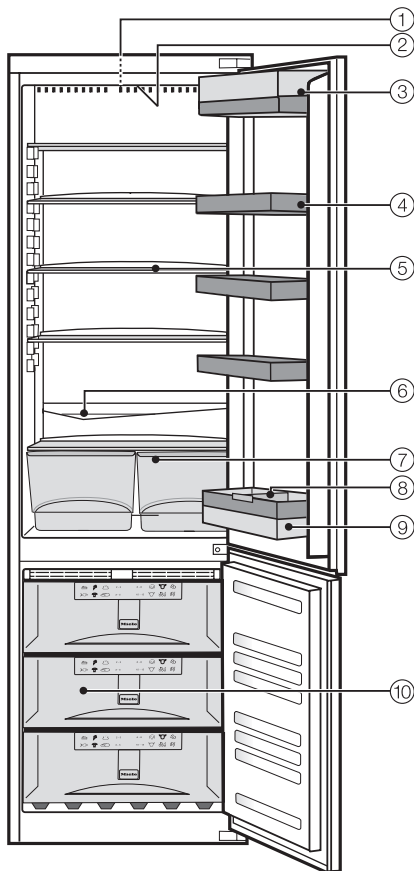

Caring for the environment

Disposal of the packing material

The transport and protective packing has been selected from materials which are environmentally friendly for disposal, and should be recycled.

Ensure that any plastic wrappings, bags etc. are disposed of safely and kept out of the reach of babies and young children. Danger of suffocation!

Disposal of your old appliance

Electrical and electronic appliances often contain materials which, if handled or disposed of incorrectly, could be potentially hazardous to human health and to the environment. They are, however, essential for the correct functioning of your appliance. Please do not therefore dispose of it with your household waste.

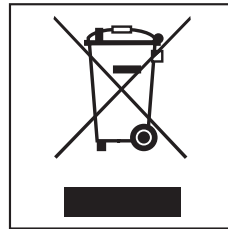

Please dispose of it at your local community waste collection / recycling centre or contact your dealer for advice. Ensure that it presents no danger to children while being stored for disposal.

Take care not to damage the pipework at the back of it before or during transportation to an authorised collection depot.

In this way, refrigerant in the pipework and oil in the compressor will be contained, and will not leak out into the environment.

Warning and Safety instructions

This appliance complies with all relevant safety requirements. Improper use can, however, present a risk of both personal injury and damage to property.

To avoid the risk of accidents and damage to the appliance, please read these instructions carefully before using it for the first time. They contain important notes on installation, safety, operation and maintenance.

Keep these instructions in a safe place and pass them on to any future user.

Correct application

▶ The appliance is not designed for commercial use. It is intended for use in domestic households and in similar working and residential environments such as:

- Shops
- Offices and showrooms
- and by residents in establishments such as:
- Hostels and guest houses.

The appliance is not intended for outdoor use.

It must only be used as a domestic appliance to cool and store food as well as to store deep frozen food, freeze fresh food and to prepare ice.

Any other usage is not supported by the manufacturer and could be

dangerous. Miele cannot be held liable for damage resulting from incorrect or improper use or operation of the appliance.

▶ The appliance can only be used by people with reduced physical, sensory or mental capabilities, or lack of experience and knowledge, if they are supervised whilst using it, or have been shown how to use it in a safe way and understand the hazards involved.

Safety with children

▶ Children 8 years and older may use the appliance only if they have been shown how to use it in a safe way and understand the hazards involved.

▶ Children under 8 years of age must be kept away from the appliance unless they are constantly supervised.

▶ This appliance is not a toy! To prevent the risk of injury, do not allow children to play with it or near it, or to play with the controls, or to swing on the door.

▶ Do not allow children to play with the packaging material, e.g. plastic bags and wrappings. Danger of suffocation.

Warning and Safety instructions

Technical safety

► Before setting up the appliance, check it for any externally visible damage. Do not install and use a damaged appliance. It could be dangerous.

► If the connection cable is faulty it must only be replaced by a service technician authorised by the manufacturer to protect the user from danger.



R600a

► This appliance contains the coolant Isobutane (R600a), a natural gas which is environmentally friendly. Although it is flammable, it does not damage the ozone layer and does not increase the greenhouse effect. The use of this coolant has, however, led to a slight increase in the noise level of the appliance. In addition to the noise of the compressor, you might be able to hear the coolant flowing around the system. This is unavoidable, but does not have any adverse effect on the performance of the appliance. Care must be taken during the transportation and installation of the appliance that no parts of the cooling system are damaged. Leaking coolant can damage the eyes.

In the event of any damage:

- avoid open flames and anything which creates a spark,
- disconnect from the mains,

- air the room in which the appliance is located for several minutes and
- contact the Service Department for advice.

► The more coolant there is in an appliance, the larger the room it should be installed in. In the event of a leakage, if the appliance is in a small room, there is the danger of combustible gases building up. For every 8 g of coolant is required at least 1 m³ of room space is required. The amount of coolant in the appliance is stated on the data plate inside the appliance.

► Safe operation of the appliance is only assured if it has been installed and connected in accordance with these operating and installation instructions.

► Before connecting the appliance, make sure that the connection data on the data plate (voltage and frequency) matches the mains electricity supply. This data must correspond in order to avoid the risk of damage to the appliance. Consult a qualified electrician if in any doubt.

► Do not connect the appliance to the mains electricity supply by a multi-socket adapter or an extension lead. These do not guarantee the required safety of the appliance (e.g. danger of overheating).

Warning and Safety instructions

- ▶ The electrical safety of this appliance can only be guaranteed when it is correctly earthed. It is most important that this basic safety requirement is observed and regularly tested and where there is any doubt, the household wiring system should be inspected by a qualified electrician. The manufacturer cannot be held liable for damage or injury caused by the lack of or inadequacy of an effective earthing system (e.g. electric shock).
- ▶ Installation, maintenance and repairs may only be carried out by a suitably qualified and competent person in strict accordance with current national and local safety regulations. Repairs and other work by unqualified persons could be dangerous. The manufacturer cannot be held liable for unauthorised work.
- ▶ While the appliance is under guarantee, repairs should only be undertaken by a service technician authorised by the manufacturer. Otherwise the guarantee will be invalidated.
- ▶ The appliance must be isolated from the electricity supply during installation, maintenance and repair work.
- ▶ Faulty components must only be replaced by genuine Miele original spare parts. The manufacturer can only guarantee the safety of the appliance when Miele replacement parts are used.
- ▶ The appliance must not be used in a non-stationary location (e.g. on a ship).
- ▶ In areas which may be subject to infestation by cockroaches or other vermin, pay particular attention to keeping the appliance and its surroundings clean at all times. Any damage caused by cockroaches or other vermin will not be covered by the guarantee.

Warning and Safety instructions

Correct use

▶ Do not handle frozen food with wet hands. Your hands may freeze to the frozen food. Danger of frost burn.

▶ Do not take ice cubes out with your bare hands and never place ice cubes or ice lollies in your mouth straight from the freezer.

The very low temperature of the frozen ice or lollies can cause frost burn to the lips and tongue.

▶ Do not refreeze partially or fully defrosted food. Consume defrosted food as soon as possible, as it will lose its nutritional value and spoil if left for too long. Defrosted food may only be re-frozen after it has been cooked.

▶ Do not store explosive materials in the appliance or any products containing propellants (e.g. spray cans). Thermostats switching on may produce sparks which could present a fire hazard. Flammable compounds could explode.

▶ Do not operate any electrical equipment (e.g. an electric ice-cream maker) inside the appliance. Danger of sparking and explosion.

▶ If storing alcohol with a high percentage proof in the refrigerator, make sure the bottle is tightly closed and stored upright. Danger of explosion.

▶ Do not store cans or bottles containing carbonated drinks or liquids which could freeze in the freezer. The cans or bottles could explode. Danger of injury and damage to the appliance.

▶ When cooling drinks quickly in the freezer, make sure bottles are not left in for more than one hour; otherwise they could burst. Danger of injury and damage to the appliance.

▶ Observe the "use-by" dates given on food to avoid the risk of food poisoning. Storage times will depend on several factors, including the freshness and quality of the food as well as the temperature at which it is stored. Follow the instructions given on the food manufacturer's packaging regarding storage conditions and "use-by" dates.

▶ Do not use sharp edged objects to

- remove frost and ice,
- separate frozen foods and remove ice trays.

They will damage the evaporator, causing irreversible damage to the appliance.

▶ Do not place electric heaters or candles in the appliance to defrost it. These will damage the plastic parts.

▶ Do not use defrosting sprays or de-icers, as they might contain substances which could damage the plastic parts or which could cause the build-up of gases and pose a danger to health.

Warning and Safety instructions

- ▶ Do not use a steam-cleaning appliance to defrost or clean the appliance. Steam could reach electrical components and cause a short circuit.
- ▶ Do not use any oils or grease on the door seals, as these will cause the seals to deteriorate and become porous with time.
- ▶ If storing food which contains a lot of fat or oil in the appliance or the refrigerator door, make sure that it does not come into contact with plastic components as this could cause stress cracks.
- ▶ Do not block the ventilation gaps in the appliance as this would impair the efficiency of the appliance, increase the electricity consumption and could cause damage to the appliance.
- ▶ The appliance is designed for use within certain climate ranges (ambient temperatures), and should not be used outside this range. The climate range for your appliance is stated on the data plate inside the appliance. Installing it in a room with too low an ambient temperature, e.g. a garage, can lead to the appliance switching off for longer periods so that it cannot maintain the required temperature.

Stainless steel appliances

- ▶ Do not use sticky notes, transparent adhesive tape, masking tape or other types of adhesive on the surface of the door.
These damage the surface, causing it to lose its dirt-repellent protective coating.
- ▶ The high-quality surface of the door is susceptible to scratching. Even fridge magnets can cause scratching.

Disposal of your old appliance

- ▶ Before disposing of an old appliance, first make the door latch or lock unusable. This way you will prevent children from accidentally locking themselves in and endangering their lives.
- ▶ Be careful not to damage any part of the pipework whilst awaiting disposal, e.g. by
 - puncturing the refrigerant channels in the evaporator.
 - bending any pipework.
 - scratching the surface coating.Splashes of refrigerant can damage the eyes.

The manufacturer cannot be held liable for damage caused by non-compliance with these Warning and Safety instructions.

How to save energy

	Normal energy consumption	Increased energy consumption
Installation site	In a ventilated room.	In an enclosed, unventilated room.
	Protected from direct sunlight.	In direct sunlight.
	Not near to a heat source (radiator, oven).	Near to a heat source (radiator, oven).
	Where the ideal ambient room temperature is approx. 20°C.	Where there is a high ambient room temperature.
	Do not cover the ventilation gaps and dust them regularly.	
Temperature setting with a thermostat which is approximate (set in stages).	With a medium setting of 2 to 3.	With a high setting: the lower the temperature in the compartment, the higher the energy consumption.
Temperature setting with a thermostat which is exact to the degree (digital display).	Larder section 8 to 12 °C	On appliances with winter setting, please make sure that the winter setting is switched off when the ambient temperature is warmer than 16 °C .
	Refrigerator section 4 to 5 °C	
	PerfectFresh zone just above 0 °C	
	Freezer section -18 °C	
	Wine storage section 10 to 12 °C	
Use	Drawers, shelves and racks arranged as they were when the appliance was delivered.	
	Only open the door when necessary and for as short a time as possible.	Frequent opening of the door for long periods will cause a loss of coldness.
	Store food in an organised way.	Searching for an item will mean the door is open for longer.
	Allow hot food and drinks to cool down before placing them in the appliance.	Hot food will cause the compressor to run for a long time, as the appliance will have to work harder to reduce the temperature.
	Store food covered or packaged.	The evaporation or condensation of liquids will cause a loss of coldness in the refrigerator.
	Place frozen food in the refrigerator to defrost.	
	Do not over-fill the appliance to allow air to circulate.	
Defrosting	Defrost the freezer section when a layer of ice 0.5 cm thick (maximum) has built up.	A layer of ice hinders the cold from reaching the frozen food, and increases energy consumption.

Before using for the first time

Protective foil

The stainless steel trim to the interior shelves and the door shelves has a layer of protective foil to prevent damage during transportation. On stainless steel appliances, the outer surfaces are also covered with protective foil.

- Do not remove the foil until the appliance has been positioned in its final location.

Cleaning and care

- Treat the stainless steel trim to the interior shelves and the door shelves with the Miele stainless steel conditioning agent supplied as soon as you have removed the foil.
- On stainless steel appliances also treat the side panels with the Miele stainless steel conditioning agent supplied as soon as you have removed the protective foil. The appliance doors have a special finish which is resistant to soiling. **Do not use** Miele stainless steel conditioning agent on the appliance doors.

Important. Miele stainless steel conditioning agent provides a protective coating which helps prevent resoiling.

- Clean the inside of the appliance and the accessories with lukewarm water and a little washing up liquid, and then dry with a soft cloth.

Switching on

The refrigerator and freezer sections are switched on together by pressing the master switch on the right hand side of the control panel, or by pressing the On button on the left hand side of the control panel.

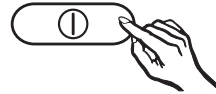

- Press the master switch on the right hand side of the control panel.

The temperature display for the refrigerator section will show the selected temperature setting. The temperature display for the freezer and the alarm indicator light will flash until the freezer section has cooled down to the correct temperature for freezing.

The appliance will start cooling down and the interior light in the refrigerator section will come on if you open the door.

To enable the temperature to get sufficiently cold inside the appliance, allow the appliance to run for a few hours before placing food in it.

Do not place food in the freezer until the temperature is at least $-18\text{ }^{\circ}\text{C}$.

Switching on and off

Switching off

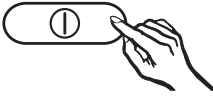

- Press the master switch on the right hand side of the control panel until both temperature displays go out.

The interior lighting will not come on when you open the door and the cooling process will be switched off.

To switch the refrigerator section off separately

The refrigerator section can be switched off without having to switch off the freezer section. This is useful e.g. whilst on holiday.

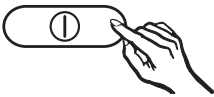

- Press the On/Off button for the refrigerator section on the left hand side of the control panel until the temperature display for the refrigerator section goes out.

The interior light will not come on when you open the door and the refrigerator section is switched off.

The temperature display for the freezer section will remain lit up.

To switch the refrigerator section on again

- Press the On/Off button on the left hand side of the control panel again.

The refrigerator section temperature display will light up. The refrigerator

section will start cooling. The interior light will come on when the door is opened.

Switching off for longer periods of time

If the appliance is not going to be used for a longer period of time, e.g. whilst on holiday:

- switch the appliance off,
- disconnect it from the mains,
- clean the appliance out and
- leave the doors ajar to air it.

If, during a long absence, the appliance is switched off but not cleaned out and the doors are left shut, there is a danger of mould and odours building up inside the appliance.

The correct temperature

It is very important to set the correct temperature for storing food in the appliance. Micro-organisms will cause food which is not stored at the correct temperature to deteriorate rapidly. Temperature influences the growth rate of these micro-organisms. Reducing the temperature reduces their growth rate.

The temperature in the appliance will rise:

- the more often the door is opened and the longer it is kept open,
- the more food that is placed in it,
- the warmer the food is which is being put into it,
- the higher the ambient temperature surrounding the appliance.

The appliance is designed for use in specific ambient temperatures (climate ranges). Do not use in ambient temperatures for which it is not designed.

... in the refrigerator section

We recommend a temperature of **5 °C** in the middle of the refrigerator.

... in the freezer section

To freeze fresh food and to store frozen food for a long time, a temperature of **-18 °C** is required. At this temperature the growth of micro-organisms is generally halted. As soon as the temperature rises above -10 °C, the micro-organisms become active in the food again so that it cannot be kept as long. For this reason, partially defrosted or defrosted food must not be re-frozen. Food may be re-frozen once it has been cooked, as the high temperatures achieved when cooking destroy most micro-organisms.

Setting the temperature

The temperature is set in each zone by using the respective temperature button.

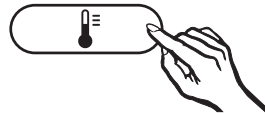

- Press the temperature button repeatedly until the indicator light for the temperature you want lights up in the display.

The first time you press the button the indicator light for the last temperature you set will flash in the display.

Thereafter the temperature value will change each time you press the button until the highest setting is reached. It will then go back to the lowest setting again.

The correct temperature

The newly selected temperature will be adopted automatically after a short while.

The indicator for the temperature which has been set for the refrigeration section will light up.

The indicator for the temperature which has been set for the freezer section will flash until that temperature is reached.

The temperature can be set to be slightly colder than the temperature range shown on the control panel for the refrigeration and freezer sections.

The following example shows how to set the freezer section temperature lower than -15 °C but not as cold as -18 °C:

- Press the temperature button repeatedly until the indicator light for -15 °C lights up in the display.
- Press it again for approx. 5 seconds to set the temperature below -15 °C.

The temperature has now been set between -15 °C and -18 °C. However, this is not visible in the temperature display.

Temperature display

The temperature display on the control panel always shows the **required** temperature.

Temperature range

The temperature can be adjusted:

- In the refrigerator section from 1 °C to 9 °C.
- In the freezer section from from -15 °C to -32 °C.

The ambient temperature in the room and the installation location can affect the time it takes for the appliance to reach the lowest temperature. If the ambient temperature is too high, the appliance may not reach the lowest temperature.

The relevant **temperature indicator light will flash** if a different temperature is being set.

The **freezer section temperature indicator light will also flash** if

- the temperature in the freezer section is not within the possible temperature range.
- the temperature in the freezer section has risen by several degrees, indicating that it is warming up too much.

The alarm off indicator will flash at the same time.

The correct temperature

This loss of coldness is no cause for concern in the following circumstances:

- when the door has been left open for a while, e.g. for removing or storing a large amount of food,
- when fresh food is being frozen.

However, if the temperature in the freezer section remains above $-18\text{ }^{\circ}\text{C}$ for a long time, check that the frozen food has not started to defrost. If it has, check that the food is safe to use and if it is, then use it as soon as possible.

Alarm

Your appliance has been fitted with a warning system which ensures that the temperature in the freezer section cannot rise unnoticed and to avoid energy being wasted if a door is left open.

Activating the alarm system

The alarm system is always active. It does not have to be switched on manually.

Temperature alarm

If the **freezer section temperature** becomes too warm, an alarm will sound and the freezer section temperature display and the alarm off indicator light will flash.

The temperature the appliance is set at determines the temperature the appliance recognises as being too warm.

The alarm will sound and the temperature display and alarm off indicator light will flash, for example,

- if the freezer door has been left open for a while, e.g. in order to load, to re-arrange or to take food out.
- when freezing large amounts of food at once.
- in the event of a power cut.
- the appliance is faulty.

If the temperature inside the appliance is warmer than -18°C for a longer period of time, check that the food has not started to thaw or defrost. If it has, check that it is still safe to eat, and use it as quickly as possible.

Once the set temperature has been reached in the freezer section, the alarm switches off and the temperature display and the alarm off indicator will stop flashing and light up constantly.

Door alarm

The alarm will sound if a door is left open for more than 60 seconds.

The alarm will stop as soon as the door is closed.

Switching the alarm off early

If the noise disturbs you, you can switch the alarm off early if you wish.

- Press the alarm off button.

The alarm will stop.

The temperature display and the alarm off indicator light will continue to flash until the set temperature has been reached.

Super freeze and Dynamic cooling

Super freeze

Switch the Super freeze function on before putting fresh food into the freezer.

This helps food to freeze quickly and retain its nutrients, vitamins, flavours and appearance.

Super freeze is not necessary:

- when placing food in the freezer that is already frozen.
- when freezing up to 2 kg fresh food daily.

Switching on Super freeze

When freezing small quantities of food in the freezer, the Super freeze function should be switched on **6 hours beforehand**. When freezing **the maximum load of food** the Super freeze function should be switched on **24 hours beforehand**.



- Press the Super freeze button. The Super freeze indicator light will come on.

The appliance works at full power to lower the temperature in the appliance.

Switching off Super freeze

The Super freeze function will switch off automatically after approx. 65 hours. The indicator light will go out and the appliance will run at normal power again.

To save energy the Super freeze function can be switched off once a **constant** temperature of -18°C or colder has been reached in the freezer.

- Press the Super freeze button. The Super freeze indicator light will go out, and the appliance will continue to operate at normal power.

Super freeze and Dynamic cooling

Dynamic cooling

When the Dynamic cooling function is not switched on, the natural circulation of air in the appliance will cause different temperature zones in the refrigerator as the cold, heavy air will sink to the lowest section of the appliance. You should bear this in mind when placing food in the appliance (see "Using the refrigerator efficiently"). However, if you are placing a large amount of food in the refrigerator at any one time, it is a good idea to switch on Dynamic cooling. This way you can distribute the temperature inside the appliance to all areas more evenly so that all the food will be chilled to about the same degree.

The temperature is set as normal with the temperature control.

Dynamic cooling should also be selected when:

- the ambient temperature in the room is high (above approx. 30 °C), and
- the room humidity level is high.

Switching on Dynamic cooling

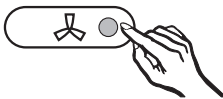

- Press the Dynamic cooling button. The Dynamic cooling indicator light will come on.

Make sure the fan at the back of the appliance is not restricted to ensure unhindered air circulation.

Switching off Dynamic cooling

- Press the Dynamic cooling button . The Dynamic cooling indicator light will go out.

The fan automatically switches off when the door is open.

Using the refrigerator efficiently

Different storage zones

Due to the natural circulation of the air in the appliance, there are different temperature zones in the refrigerator. Cold, heavy air sinks to the lowest section of the appliance. Make use of the different zones when placing food in the appliance.

This appliance has Dynamic cooling, which helps to keep an even temperature when the fan is running. When Dynamic cooling is switched on, the difference between the various zones is less pronounced.

Warmest area

The warmest area is in the top section of the door. Use this for storing butter and cheese.

Coldest area

The coldest area in a refrigerator is directly above the vegetable containers.

Use this for all delicate and highly perishable food, e.g.

- fish, meat, poultry,
- sausage products, ready meals,
- dishes or baked goods containing eggs or cream,
- fresh dough, cake mixtures, pizza or quiche dough,
- soft cheese and other dairy products,

- pre-packed vegetables and other fresh food with a label stating it should be kept at a temperature of approx. 4 °C.

Do not store explosive materials in the appliance or any products containing propellants (e.g. spray cans). Danger of explosion.

If storing alcohol with a high percentage proof, make sure it is tightly closed, and store upright.

If storing food which contains a lot of oil or fat in the refrigerator or refrigerator door, make sure it does not come into contact with plastic components as this could cause stress cracks.

Food must not touch the back wall of the refrigerator, as it may freeze to the back wall.

To allow air to circulate efficiently, do not pack food too closely together in the refrigerator. Do not cover the fan in the rear wall of the refrigerator, as this is essential for keeping the appliance cool.

Using the refrigerator efficiently

Food which should not be stored in a refrigerator

Not all food is suitable for refrigeration, as some food is sensitive to cold. Cucumbers, for example, become glassy, aubergines bitter and potatoes sweet. Tomatoes and oranges lose their aroma, and the peel on citrus fruit hardens.

Food which should not be stored in a refrigerator includes:

- pineapple, pomegranate, bananas, avocado, mangos, papaya, passion fruit, citrus fruit
- fruit which is not yet ripe
- aubergines/egg plant, cucumbers, potatoes, peppers/capsicum, tomatoes, courgettes,
- some hard cheeses, e.g. Parmesan

When shopping for food

The freshness of food when first placed in the appliance is an important factor in determining how long it stays fresh, and how long it can be kept in the refrigerator. Time out of the refrigerator, e.g. during transportation, should be kept to a minimum. For example, do not allow food to stay in a hot car for too long. Once food has started to deteriorate, this process cannot be reversed. As little as two hours outside the refrigerator can cause food to start deteriorating.

Storing food correctly

Food should generally be stored covered or packaged. This will prevent food smells from affecting other foods, food from drying out, and also any cross-contamination of bacteria. The growth of bacteria, such as salmonella, can be avoided by setting the correct temperature and maintaining good standards of hygiene.

Fruit and vegetables

Fruit and vegetables may be stored loose in the vegetable containers. Please be aware that not all types of fruit and vegetables are suitable for storing in the same container. Aromas and flavours can transfer from one type of food to another (e.g. carrots absorb the smell and flavour of onions very easily). Some food also gives off a natural gas (ethylene) which speeds up the rate at which other food perishes.

– Examples of fruit and vegetables which produce a large amount of this natural gas are:

Apples, apricots, pears, nectarines, peaches, plums, avocado, figs, blueberries, melons and beans.

Using the refrigerator efficiently

– **Examples of fruit and vegetables which react strongly to the natural gases given off by other types of fruit and vegetables are:**

Kiwis, broccoli, cauliflower, brussels sprouts, mangos, honeydew melons, apples, apricots, cucumbers, tomatoes, pears, nectarines and peaches.

Example: Broccoli should not be stored with apples, as apples produce a large amount of natural gas to which broccoli is very sensitive. The result is a shorter than expected storage time for the broccoli.

Unpacked meat and vegetables

Unpackaged meat and vegetables should be stored separately. To avoid any microbiological cross-contamination, these foods may only be stored together if they are wrapped.

Protein rich foods

Please note that foods rich in protein deteriorate faster than others. Shellfish, for example, deteriorates faster than fish, and fish deteriorates faster than meat.

Meat

Meat should be stored unwrapped. (Undo wrappings slightly to leave meat loosely covered, and leave containers open). This permits air to circulate around the meat, allowing the surface to dry slightly, which helps prevent the growth of bacteria. To prevent the risk of bacterial cross-contamination and meat deteriorating, do not let one type of meat come into direct contact with another type.

Adjusting the interior fittings

Moving the shelves

The shelves in the refrigerator section can be adjusted according to the height of the food.

- Raise the shelf, and pull it forwards slightly until the notch at the side is in line with the shelf support. It can then be raised or lowered to the required level.

The raised edge at the back must face upwards to prevent food from touching the back of the appliance and freezing to it.

Stoppers prevent the shelves from being dislodged by mistake.

Split shelf

In order to accommodate tall items in the appliance, one of the shelves is divided. The front section can be pushed under the rear section.

- Push the rear half of the glass shelf up slightly from below.
- At the same time, pull the front half of the glass shelf forwards slightly and then push it carefully under the rear half.

To move the split shelf:

- Take both halves of the split glass shelf out,

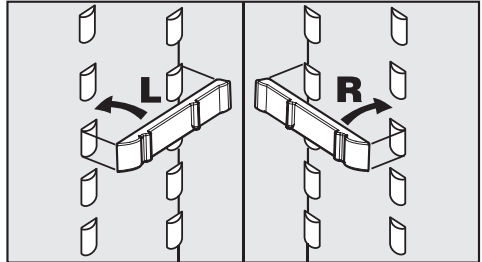

- fit the two brackets onto the supports on either side at the required height,
- and push the glass shelves in one after the other.
The shelf with the raised edge must be at the back.

Fruit and vegetable containers on rollers

The fruit and vegetable containers are pushed in and out on rollers, and can be completely removed if necessary. The rollers can also be removed for cleaning.

Adjusting the interior fittings

Adjusting the condiment tray/bottle shelf

- Lift the tray/shelf up and out of the stainless steel frame to remove.
- Push up the stainless steel frame, and remove.
- Replace the frame at the required height. Ensure that it is securely pushed back into position.

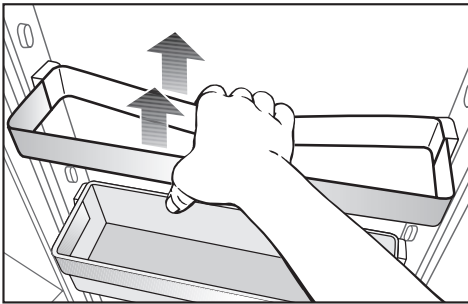

- Some stainless steel frames are easier to remove and replace if you put your hand behind the back bar of the frame and lift it upwards.
- Replace the tray/shelf in the frame.

The tray/shelf can be removed completely and used as a serving tray at the table.

Universal container

The universal container can be used both to store and serve food.

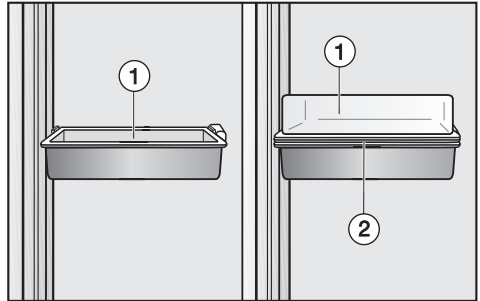

It consists of a deep tray ① and a shallow tray ②. Both trays fit the stainless steel frame.

If you wish to use the universal container to serve food,

- place the shallow tray ② in the stainless steel frame, and use the deep tray as a lid ①.

You can lift the universal container, including contents, out of the frame and take it to the table.

Moving the bottle divider

The bottle divider can be moved to the left or right to ensure that bottles are held securely in position when the door is opened and shut.

The bottle divider can be removed completely (e.g. for cleaning).

- To do this, push up the front edge of the bottle divider, and disengage it.

Freezing and storing food

Maximum freezing capacity

To ensure that fresh food placed in the freezer freezes through to the core as quickly as possible, the maximum freezing capacity must not be exceeded. The maximum freezing capacity for freezing within a 24-hour period is given on the data plate: "Freezing capacitykg/24 hrs".

The maximum freezing capacity given on the data plate has been calculated according to DIN EN ISO 15502 Standard.

Freezing fresh food

Fresh food should be frozen as quickly as possible. This way the nutritional value of the food, its vitamin content, appearance and taste are not impaired.

Food which takes a long time to freeze will lose more water from its cells, which then shrink.

During the defrosting process, only some of this water is reabsorbed by the cells; the rest collects around the food.

In practice this means that the food loses a large degree of its moisture. You can tell if this has happened by the amount of liquid around the food.

If food is frozen quickly, the cells have less time to lose moisture, so they shrink less. As there is not so much moisture loss, it is easier for the food to reabsorb it during the defrosting process, and very little water collects around the defrosted food.

Storing frozen food

When buying frozen food to store in your freezer, check

- that the packaging is not damaged,
 - the use-by date,
 - the temperature at which the frozen food is being stored in the shop. The length of time it can be kept is reduced if it has been stored at a temperature warmer than -18 °C.
- Buy frozen food once you have finished the rest of your shopping, and wrap it in newspaper or use a cool bag or cool box to transport it.
 - Store it in the freezer as soon as possible.

Never re-freeze partially or fully defrosted food. Consume defrosted food as soon as possible as it will lose its nutritional value and spoil if left for too long. Defrosted food may only be re-frozen after it has been cooked.

Home freezing

Only freeze fresh food which is in a good condition.

Hints on home freezing

- The following types of food **are suitable** for freezing:
Fresh meat, poultry, game, fish, vegetables, herbs, fresh fruit, dairy products, pastry, leftovers, egg yolks, egg whites and a range of pre-cooked meals.
- The following types of food **are not suitable** for freezing:
Grapes, lettuce, radishes, sour cream, mayonnaise, eggs in their shells, onions, whole raw apples and pears.
- To retain colour, taste and vitamin C, vegetables should be blanched after they have been trimmed and washed.
To blanch: bring a large saucepan of water to the boil, immerse the vegetables in the fast boiling water for 2-3 minutes, depending on variety. Remove, and plunge into ice-cold water to cool quickly. Drain and pack ready for freezing.
- Lean meat freezes better than fatty meat, and can be stored for considerably longer.
- To prevent chops, steaks, cutlets or rolled meat from freezing together in solid blocks when packed, separate with a sheet of plastic freezer film.

- Do not season fresh food or blanched vegetables before freezing. Only season cooked food lightly before freezing, but care should be taken as the taste of some spices alters when frozen.
- Do not place hot food or drinks in the freezer. This causes already frozen food to thaw, and increases the energy consumption considerably. Allow hot food and drinks to cool down before placing them in the freezer.

Packaging

- Freeze food in portions.

Unsuitable packaging material

- wrapping paper
- grease-proof paper
- cellophane
- bin bags
- plastic carrier bags

Suitable packaging material

- plastic freezer film
- freezer bags
- aluminium foil
- freezer containers
- Expel as much air as possible from bags etc. before sealing them, to prevent freezer-burn on food.
- Close the packaging tightly with
 - rubber bands
 - plastic clips
 - string or bag ties
 - freezer tape.

Freezer bags may also be sealed using home heat sealing kits.

Freezing and storing food

- Make a note of the contents and the date of freezing on the packaging.

Before placing food in the freezer section

- When freezing more than 2 kg of fresh food, switch on the Super freeze function some time before placing the food in the freezer (see "Super freeze").
This also helps food that is already in the freezer to stay frozen.

Placing food in the freezer section

The following maximum capacities must be observed:

- freezer drawer = 25 kg
- glass cold plate = 35 kg

Food to be frozen must on no account touch food which is already frozen to avoid partial thawing.

- Make sure that the packaging and containers are dry to prevent them sticking together when frozen.

– Freezing small amounts of food

Place the food in the upper freezer drawers.

- Place the food flat in the bottom of the drawers so that it freezes through to the core as quickly as possible.

Please note that when removing the drawers, the lowest freezer drawer must always remain in the freezer. When placing food on the glass cold plate make sure it does not obstruct the ventilation gaps at the back. This is important for problem-free operation and normal energy consumption.

– Freezing the maximum amount (see data plate)

- Remove the upper freezer drawers.
- Place the food flat on the upper glass cold plates so that it freezes through to the core as quickly as possible.

Once frozen:

- Place the frozen food in the freezer drawers and push them back into the appliance.

– Large items





If you wish to freeze large items such as a turkey or game, the glass cold plates between the drawers can be removed.

- Remove the upper freezer drawers and carefully lift and slide out the glass cold plates.

Freezer calendar

The freezer calendar on the freezer drawer gives the length of time in months which various foods can be stored for effectively.

Where the storage time given on the packaging differs, follow the advice on the packaging.

	2 - 3	6 - 8	
	3 - 5	10 - 12	

2-3 months:

Cakes, ice cream, stew

3-5 months:

Fish, mushrooms, bread

6-8 months:

Pork, veal, poultry

10-12 months:

Beef, fruit, vegetables

Defrosting

Frozen food can be defrosted in different ways:

- in a microwave oven,
- in an oven using the "Fan" or "Defrost" setting,
- at room temperature,
- in the refrigerator (the cold given off by the frozen food helps to keep the other food cold),
- in a steam oven.

Poultry It is particularly important to observe food hygiene rules when defrosting poultry. Do not use the liquid from defrosted poultry. Pour it away and wash the container it was in, the sink and your hands. Danger of salmonella poisoning.

Ensure that **meat and fish** (e.g mince, chicken, fish fillets) do not come into contact with other foods while defrosting. Catch the liquid and dispose of it carefully.

Fruit should be defrosted at room temperature in its packaging, or in a covered bowl.

Most vegetables can be cooked while still frozen. Just put straight into boiling water or hot fat. The cooking time is slightly less than that of fresh vegetables due to changes in the cell structure.

Freezing and storing food

Do not re-freeze partially or fully defrosted food. Consume defrosted food as soon as possible as it will lose its nutritional value and spoil if left for too long. Defrosted food may only be re-frozen after it has been cooked.

Ice cubes

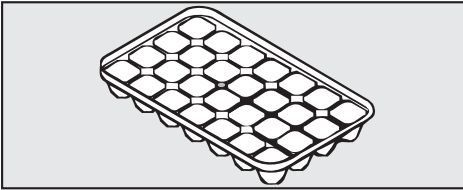

- Fill the ice tray three quarters full with water, and place it in the bottom of one of the drawers.
- Once frozen, use a blunt instrument, for example a spoon handle, to remove the ice tray from the freezer.
- Ice cubes can be removed easily from the tray by twisting the tray gently or by holding it under cold running water for a short while.

Cooling drinks

Do not store cans or bottles containing carbonated drinks or liquids which could freeze in the freezer. The cans or bottles could explode.

When cooling non-carbonated drinks quickly in the freezer, make sure bottles are not left in for more than one hour, otherwise they could burst.

Refrigerator section

The refrigerator defrosts automatically.

Condensate and frost can build up on the back wall of the refrigerator section whilst it is in use. You do not need to remove this, as it will defrost and evaporate automatically with the warmth generated by the appliance.

The condensate is drained away via a channel and drain hole into an evaporation system at the back of the appliance.

Ensure that the condensate channel and drain hole are kept clean and are never blocked so that condensate can flow away without hindrance.

Freezer section

This appliance is equipped with a "Frost free" system. The freezer section defrosts automatically.

The moisture generated in the appliance collects on the condenser and is automatically defrosted and dissipated from time to time.

This automatic defrosting system enables the freezer section to remain permanently ice-free, however, the food stored in the freezer section will not defrost.

Cleaning and care

A range of Miele branded cleaning and conditioning products is available to order from Miele or www.miele-shop.com.

Make sure that no water can penetrate into the electronic unit or into the light.

Do not let water get into the condensate channel and drain hole when cleaning.

Do not use steam cleaning apparatus to clean the appliance. Steam could reach electrical components and cause a short circuit.

The data plate located inside the appliance must not be removed. It contains information which is required in the event of a service call.

The stainless steel doors have a special finish which is resistant to soiling.

Do not treat the doors with stainless steel conditioning agent as this will cause noticeable smearing.

However, do use Miele stainless steel conditioning agent to treat the other stainless steel surfaces of the appliance (available from Miele or www.miele-shop.com).

Unlike stainless steel cleaning agents, the conditioning agent does not contain any abrasive substances and will gently remove soiling. Each time it is used, it forms a water and dirt repellent protective coating.

To avoid damaging the surface of your appliance, do not use:

- cleaning agents containing soda, ammonia, acids or chlorides,
- cleaning agents containing descaling agents,
- abrasive cleaning agents, e.g. powder cleaners and cream cleaners,
- solvent-based cleaning agents,
- stainless steel cleaning agents,
- dishwasher cleaner,
- oven sprays,
- glass cleaning agents,
- hard, abrasive sponges and brushes, e.g. pot scourers,
- melamine eraser blocks,
- sharp metal scrapers.

Before cleaning

- Switch the appliance off.
- Disconnect it from the mains.
- Take any food out of the appliance and store it in a cool place.
- Take out any removable parts, e.g. shelves, for cleaning.

- The bottle shelf and condiment tray in the door can be removed from their stainless steel frames for cleaning.

To remove the stainless steel trim from the lid of the butter and cheese compartment (in the top of the door), proceed as follows:

- Take the butter and cheese compartment out of the refrigerator section.
- Open the lid of the compartment.

The stainless steel trim is a tight fit across the plastic lid and will require sufficient force to detach it.

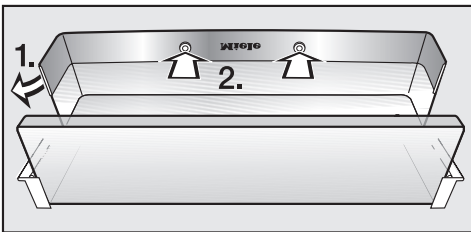

- Detach the stainless steel trim from the edge of the lid (1.) at one side and remove.
- Press the white plastic stoppers out of notches (2.).
- After cleaning, refit the stainless steel trim onto the lid in the reverse order.

Cleaning the interior and accessories

- Clean the appliance at least once a month.

Remove soiling immediately to prevent it from drying on.

Use lukewarm water with a little washing-up liquid.

The following are dishwasher safe:

- the butter dish, egg trays, ice cube tray (supplied as standard, depending on model)
- the bottle shelf and condiment tray in the door (removed from their stainless steel frames)
- the butter and cheese compartment (with the stainless steel trim removed)

The stainless steel frames and the stainless steel trim on the butter and cheese compartment in the door are **not** suitable for cleaning in a dishwasher.

The temperature of the dishwasher programme must not exceed 55 °C. Contact with some foodstuffs, such as carrots, tomatoes or ketchup can cause plastic items to discolour. However, this discolouration will not affect the stability of plastic items.

- Clean the interior shelves and drawers by hand. These are **not** suitable for cleaning in a dishwasher.

Cleaning and care

- Clean the condensate channel and drain hole frequently, so that condensate can drain away unhindered. Use a straw or similar to clear the drain if necessary.
- After cleaning, wipe the interior and accessories with a damp cloth and dry with a soft cloth. Leave the doors open to air the appliance for a short while.
- Miele stainless steel conditioning agent can be used to remove any soiling.
- It is important to treat the stainless steel frames and trim with Miele stainless steel conditioning agent each time they are cleaned. This will protect the surface and help prevent resoiling.

Appliance doors, side panels

Remove any soiling on the appliance doors and side panels immediately. If this is not done, it might become impossible to remove and could cause the surface to alter or discolour.

All surfaces are susceptible to scratching. Contact with unsuitable cleaning agents can alter or discolour the surfaces.

- The surfaces should be cleaned using a solution of hot water and a little washing-up liquid applied with a soft sponge. They can also be cleaned with a damp microfibre cloth (without using any cleaning agent).
- After cleaning, wipe with a damp cloth and dry with a soft cloth.

Stainless steel appliances

– Appliance doors

The appliance doors have a high quality, special finish which is resistant to soiling and is very easy to clean.

Do not use the following to clean/condition the doors

- stainless steel cleaning agent: this will damage the surface.
- Miele stainless steel conditioning agent: this will cause noticeable smearing.

– Side panels

- Use Miele stainless steel conditioning agent to remove any soiling from stainless steel surfaces.
- **Make sure** you treat the side panels with Miele stainless steel conditioning agent each time you clean them. This will give them a water and dirt repellent protective coating and help prevent re-soiling.

Ventilation gaps

- The ventilation gaps should be cleaned regularly with a brush or vacuum cleaner. A build-up of dust will increase the energy consumption of the appliance.

Door seals

Do not use any oils or grease on the door seals as these will cause the seals to deteriorate and become porous over time.

The door seals should be cleaned regularly with clean water, and then wiped dry with a soft cloth.

Metal grille at the back of the appliance

The metal grille at the back of the appliance (heat exchanger) should be dusted at least once a year. A build-up of dust will increase the energy consumption of the appliance.

When cleaning the grille, make sure that the cable, pipework and other components do not get broken, kinked or damaged in any way.

After cleaning

- Replace all shelves and accessories in the refrigerator section.
- Put the food back in the refrigerator.
- Reconnect the appliance to the mains and switch it back on.
- Switch on the Super freeze function so that the freezer can cool down quickly.
- Once the freezer has reached the required temperature, place the food back in the freezer drawers and put them back in the freezer.
- Switch off the Super freeze function as soon as the temperature in the freezer is a constant -18 °C or colder.

Problem solving guide

Repairs to electrical appliances should only be carried out by a suitably qualified and competent person in strict accordance with current local and national safety regulations. Repairs and other work by unqualified persons could be dangerous. The manufacturer cannot be held liable for unauthorised work.

What to do if . . .

. . . the appliance does not get cold.

- Check whether the appliance has been switched on. The temperature display must be lit up.
- Check that the plug is correctly inserted into the socket and switched on.
- Check that the fuse is not defective and the mains fuse has not tripped. If it has, there could be a fault with the household electrical wiring, the fridge-freezer or another electrical appliance.
Contact a qualified electrician or Miele Service.

. . . the temperature in the refrigerator section or freezer section is too low.

- Set a warmer temperature.
- The Super freeze function is still on and the Super freeze indicator light is on.
The Super freeze function switches itself off automatically after approx. 65 hours.

- Check that the doors have been closed properly.
- Has a large amount of fresh food been frozen at the same time?
This makes the compressor run for longer, causing the temperature in the refrigerator to fall automatically.

. . . the compressor is switching in too frequently and for too long.

- Check whether the ventilation gaps have been covered over or become dusty.
- Check whether the metal grille (heat exchanger) at the back of the appliance has become too dusty.
- The refrigerator door or the freezer door has been opened too frequently, or a large amount of fresh food has been put in at once for freezing.
- Check that the doors have been closed properly.

. . . the frozen food is thawing because the freezer section is too warm.

- Is the room temperature lower than the ambient temperature for which the appliance is designed?

If so, increase the temperature of the room.

Operating in a room which is too cold will cause the cooling system to switch off for too long, causing the freezer to become too warm.

... food has frozen together.

Use a blunt instrument, e.g. a spoon handle or plastic scraper, to prise it apart carefully.

... the door to the freezer section will not open because it has been opened and closed too many times in succession.

This is not a fault. The suction caused by opening and closing the door several times in succession is preventing it from opening. Wait a few minutes and then try again. It should now open without force.

.. the alarm sounds.

Has one of the the appliance doors been open for longer than 60 seconds?

- Close the door.

... the alarm sounds and the freezer section temperature display flashes.

The freezer section temperature has risen above the set temperature because

- the freezer section door has been opened too frequently, or large amounts of fresh food have been put in at once for freezing.
- the ventilation gaps are blocked.

Once the problem has been resolved the freezer section temperature display will light up constantly and the alarm will go off.

... the Super freeze indicator light and one of the temperature display lights are flashing at the same time.

There is a fault. Call Miele Service.

... the interior lighting in the refrigerator is not working.

- Was the refrigerator section door left open for too long? The lighting switches itself off automatically after approx. 15 minutes if the door is left open.

If this is not the case, then the interior lighting is defective.

- Disconnect the appliance from the mains.

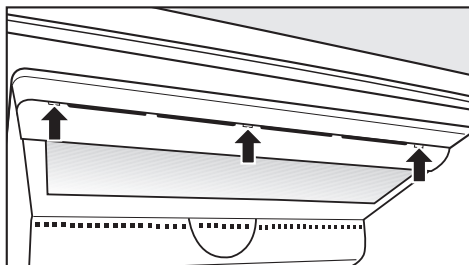

- Unclip the front cover.

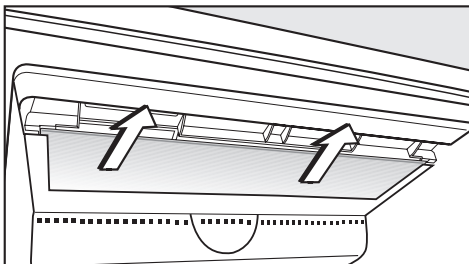

- Remove the glass panel.

Problem solving guide

- Unscrew the lamp and replace it with a new one.

Lamp specification:

220 - 240 V, max. 25 W, E 14 cap.

- Slide the glass panel back in again.
- Insert the cover and clip it into position.

. . . the floor of the refrigerator section is wet.

The condensate drain hole is blocked.

- Clean the condensate channel and drain hole.

If you still cannot remedy the fault having followed these suggestions, please contact Miele Service.

To prevent unnecessary loss of temperature it is advisable not to open the door while waiting for the appliance to be serviced.

Normal noises	What causes them
Brrrrr...	Humming noise made by the motor (compressor). This noise can get louder for brief periods when the motor is switching on.
Blubb, blubb....	A gurgling noise can be heard when coolant is circulating through the pipes.
Click....	Clicking sounds are made when the thermostat switches the motor on and off.
Sssrrrrr....	On multi-zone and frost-free appliances you can sometimes just hear the movement of air circulating inside the appliance.
Creak ...	Creaking sounds can be heard when material inside the appliance expands.

Remember that the noise of the compressor and the coolant circulating in the system is unavoidable.

Noises that you can easily rectify	What causes them, and what can you do about them
Rattling, vibrating	The appliance is uneven: Realign the appliance using a spirit level, by raising or lowering the screw feet underneath the appliance.
	The appliance is touching another appliance or piece of furniture: Move it away.
	Drawers, baskets or shelves are unstable or sticking: Check all removable items and refit them correctly.
	Are any bottles or containers unstable or knocking against each other? Separate them.
	The transport cable clips are hanging loose at the back of the appliance: Remove the clips.

After Sales / Guarantee

In the event of a fault which you cannot correct yourself, or if the appliance is under guarantee, please contact:

– your Miele Dealer

or

– Miele
(see back cover for contact details).

When contacting your Dealer or Miele, please quote the model and serial number of your appliance. This information is given on the data plate inside your appliance.

Please note that telephone calls may be monitored and recorded for training purposes.

N.B. A call-out charge will be applied for service visits where the problem could have been resolved as described in these instructions.

Guarantee

For information on the appliance guarantee specific to your country please contact Miele. See back cover for contact details.

In the U.K. your appliance is guaranteed for 2 years from the date of purchase. However, you must activate your cover by calling 0845 365 6640 or registering online at www.miele.co.uk.

Electrical connection U.K.

All electrical work should be carried out by a suitably qualified and competent person in strict accordance with current local and national safety regulations (BS 7671 in the UK).

The appliance is supplied with a mains cable and moulded plug ready for connection to an a.c. single phase 220-240 V 50 Hz supply.

Please ensure that the connection data quoted on the data plate match the household mains supply.

Connection should be made via a suitable switched socket which is easily accessible. For extra safety it is advisable to protect the appliance with a suitable residual current device (RCD).

Do not connect the appliance to the mains electricity supply by an extension lead. Extension leads do not guarantee the required safety of the appliance (e.g. danger of overheating).

This appliance must not be connected to the inverter of an autonomous power supply, e.g. a solar power system. When switching the appliance on, a surge in power could trigger the safety cut-out mechanism. This could damage the electronic unit.

The appliance must not be used with so-called energy saving devices. These reduce the energy supply to the appliance which could then become too warm. Using such devices could alter the specification of the product.

Non-rewireable plugs (BS 1363)

The fuse cover must be re-fitted when changing the fuse, and if the fuse cover is lost, the plug must not be used until a suitable replacement is obtained. The colour of the correct replacement cover is that of the coloured insert in the base of the plug, or the colour that is embossed in words in the base of the plug (as applicable to the design of the plug fitted).

Replacement fuses should be ASTA approved to BS 1362 and have the correct rating. Replacement fuses and fuse covers may be purchased from your local electrical supplier.

WARNING
THIS APPLIANCE MUST BE
EARTHED

Installation

Do not place any appliance which gives off heat, such as a toaster or microwave oven, on top of this appliance, as this would increase the appliance's energy consumption.

This appliance must not be installed directly next to another refrigerator or freezer. It does not have side-wall heating, so installation next to another refrigerator or freezer could cause a build-up of condensation between them. Further information is available from your dealer.

Important: tropical / humid environments

During periods of high humidity, some condensation may appear on outside surfaces of cooling appliances. This condensation will disappear when humidity levels drop. For prevention, it is advisable to install the appliance with sufficient ventilation in a dry and/or an air-conditioned room. Please ensure that doors are closing and sealing properly. Please ensure that the appliance is installed in accordance with these installation instructions and that the handle is fitted correctly. Should you require further assistance please contact your Miele customer service centre.

Location

This appliance should be installed in a dry, well-ventilated room. It should not be installed where it is exposed to direct sunlight or directly adjacent to a heat-producing appliance such as an oven or a radiator. The room temperature should not go above or below the climate range for which the appliance is designed. The higher the ambient temperature of the room, the more energy the appliance requires to operate.

Climate range

The appliance is designed for use within certain climate ranges (ambient temperatures), and should not be used outside this range. The climate range of the appliance is stated on the data plate inside the appliance.

Climate range	Ambient room temperature
SN	+10°C to +32°C
N	+16°C to +32°C
ST	+16°C to +38°C
T	+16°C to +43°C
SN-ST	+10°C to +38°C
SN-T	+10°C to +43°C

Operating in a room which is too cold will cause the cooling system to switch off for too long, causing the internal temperature in the appliance to rise with the risk of frozen food deteriorating and going off.

Ventilation

Air at the back of the appliance gets warm. To ensure sufficient ventilation, the ventilation gaps must not be covered or blocked in any way. They should be dusted on a regular basis.

Installation

- Remove the cable clip from the back of the appliance.
- Check that all parts at the back of the appliance are unhindered. Carefully remove any hindrance.
- Carefully push the appliance into position with the back against the wall.

Aligning the appliance

- To align the appliance, adjust the feet using the spanner supplied.

Levelling the appliance door

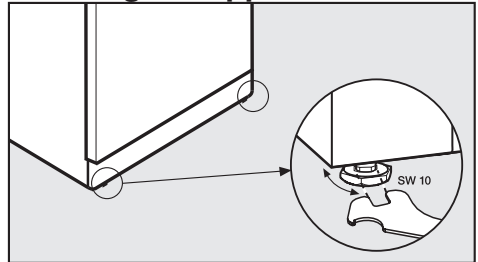

- **Ensure** that you unscrew adjusting foot ① from the hinge plate until it sits on the floor. Then unscrew the foot by a further 90°.

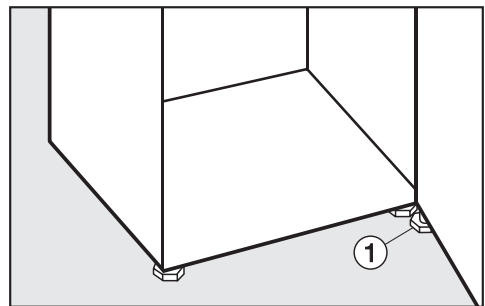

Installation

Appliance dimensions

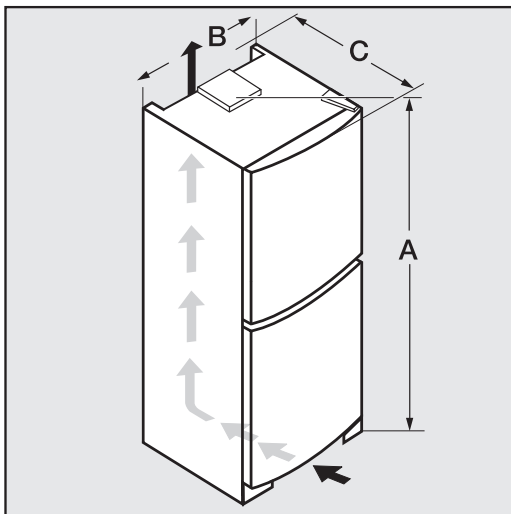

	A	B	C
KFN 12943 SD edt/cs	2020	750 mm	630 mm

Changing the door hinging

The appliance is supplied right-hand hinged. If left-hand door hinging is required, follow the instructions below.

To change the door hinging you will need the following tools:

- a cross-slotted screwdriver,
- a flat-bladed screwdriver,
- a selection of Torx screwdrivers,
- a spanner.

Two people are needed for changing the door hinging.

Removing the door handles

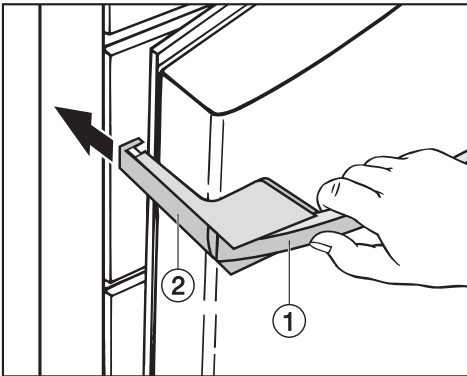

- Pull door handle ① towards you. Side section ② slides back.
- Pull side section ② firmly back out of the guides on the mounting plate.
- Undo the 4 screws (Torx 15) in the mounting plate, and remove the handle.
- Remove the cover caps from the opposite side, and fit them into the empty holes.

Changing the door hinging

Removing the doors

Make sure the door shelves are empty.

- Close the upper door.

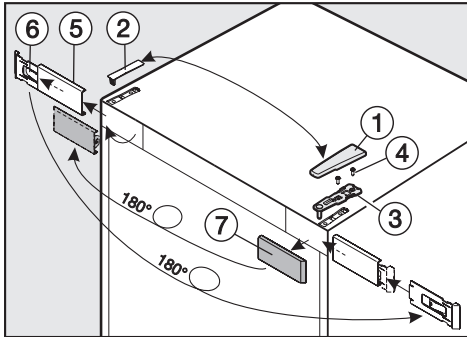

- Remove cover ① by sliding it forwards from the back and then lifting it off.
- Remove cover ② by pulling it upwards.

Caution. The upper door is not secure as soon as the upper hinge plate is removed.

- Loosen screws ④ in upper hinge plate ③ and pull it upwards and off.
- Carefully lift the upper door off and place it to one side.
- Carefully ease off cover ⑤ from above using a screwdriver and then take it off together with retaining plate ⑥.
- Then separate retaining plate ⑥ from cover ⑤, by pushing it slightly to the left and then pulling the cover forwards and off.

- Rotate retaining plate ⑥ by 180°.
- Then fit cover ⑤ from the front over retaining plate ⑥, and slide it over to the right. The writing must be visible.
- Remove cover ⑦, then rotate it by 180° and fit it on the opposite side.
- Then fit cover ⑤ together with retaining plate ⑥ on the opposite side.

Changing the door hinging

- Close the lower appliance door.

Caution. The lower door is not secure as soon as the middle hinge plate is removed.

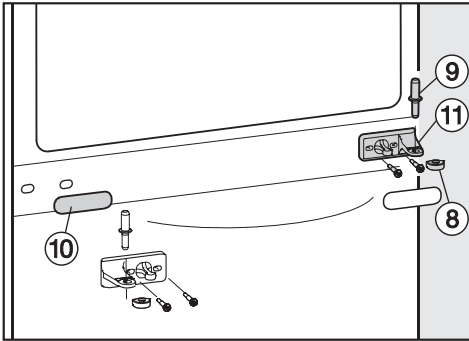

- Pull the middle hinge pin ⑨ upwards to remove it.
- Carefully lift the lower door off and place it to one side.
- Pull cover ⑩ off.
- Unscrew hinge plate ⑪, turn it through 180° and fit it on the opposite side.
- Pull off plastic cap ⑧, turn it through 180° and fit it back on to hinge plate ⑪.
- Refit cover ⑩ on the opposite side.

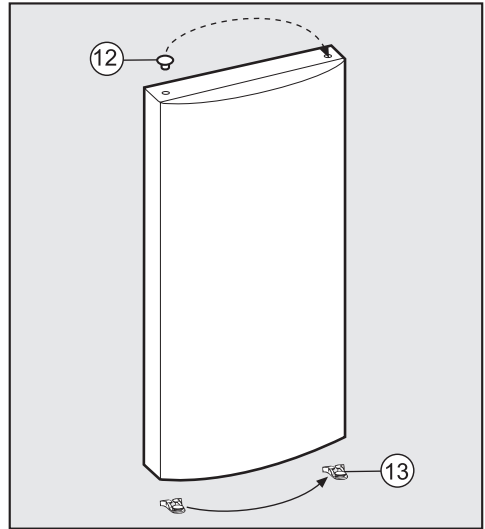

- Remove cap ⑫ from the bearing bush in the door and refit on the opposite side.

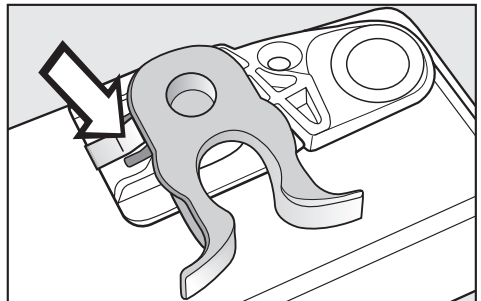

- Using a screwdriver, remove spring clamp ⑬ from underneath the door and fit it on the opposite side.

Changing the door hinging

Changing over the doors

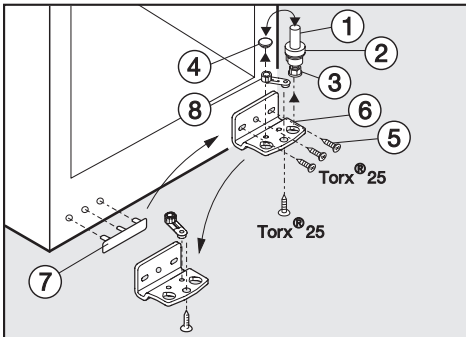

- Pull hinge pin ① together with disc ② and adjustable foot ③ upwards and off.
- Remove cover cap ④.
- Undo screws ⑤ and take hinge plate ⑥ off.
- Undo the screw of hinge part ⑧ on hinge plate ⑥ slightly. Fit it into the hole opposite in hinge plate ⑥ and tighten up the screw.
- Refit cover cap ④ in the other hole.
- Remove cover ⑦ and fit it into the holes on the opposite side.

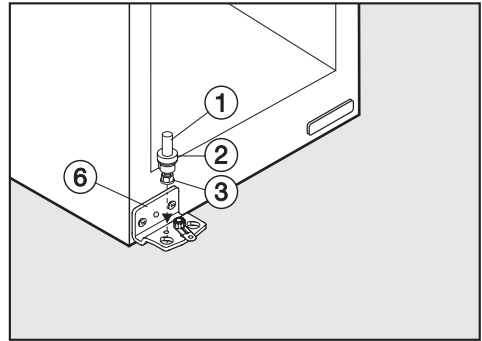

- Screw hinge plate ⑥ into position on the opposite side using the two **outer** long slots only. To make it possible to align the door later, do not replace the **centre** screw at this stage.
- Important. Screw the adjustable foot ③ into hinge pin ① as far as it will go.
- Refit hinge pin ① together with disc ② and adjustable foot ③. Important. The notch at the bottom of the hinge pin should face towards the back.
- Place the door onto hinge pin ①.
- Close the lower appliance door.

Changing the door hinging

- Fit hinge pin ⑨ into middle hinge plate ⑩ in the lower door. The ridge on the hinge pin will fit into the notch in the hinge plate.
- Then fit the upper door on middle hinge pin ⑨.
- Close the upper door.

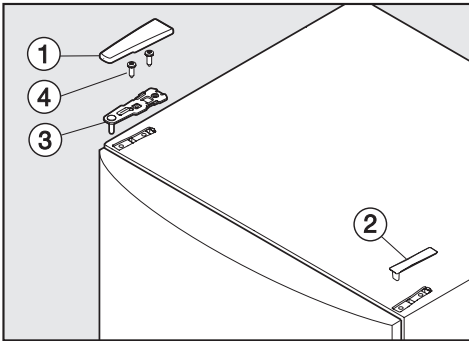

- Fit hinge plate ③ onto the opposite side and secure it with screws ④. If necessary drill pilot holes for the screws or use a battery operated screwdriver.
- Fit covers ① and ② to their opposite sides.

Changing the door hinging

Refitting the handles

Please make sure you follow the instructions below carefully when you refit the handles. The door seal will be damaged if the handle is fitted incorrectly.

It is important to check that the side section of the handle ④ does not come into contact with the door seal when opening the door, as this would damage the door seal permanently.

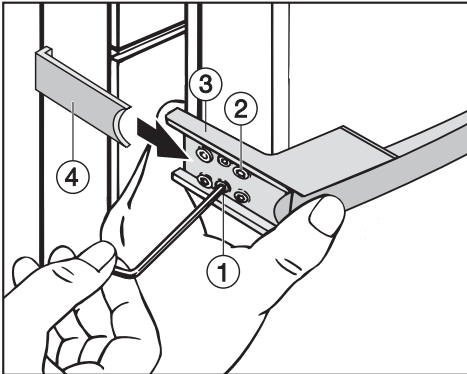

If, after you have refitted the handle, you find that the side section does touch the door seal when the door is opened:

- Realign mounting plate ③ with grub screws ① until the mounting plate and the side section of the handle ④ are at the correct angle and the side section does not touch the door seal when the door is opened.

- Loosely attach the handle to the opposite side of the door with the two front screws ②.

Mounting plate ③ must be positioned on the side of the door so that when the door is **closed** it is flush with the side of the appliance.

If this is not the case,

- tighten both grub screws ① with a suitable allen key until mounting plate ③ lines up correctly.
- Then tighten all 4 screws ②.
- Slide the side section of the handle ④ into the guides on the mounting plate until it clicks into place.

Aligning the appliance doors

The appliance doors can be aligned with the housing after they have been fitted.

In the following illustration the door is not shown in the closed position to make it easier to see what you have to do.

To align the **lower door** use the long outer slots in the lower hinge plate:

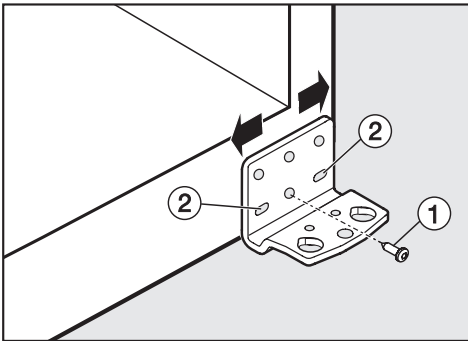

- Remove centre screw ① from the hinge plate.
- Slightly loosen both outer screws ②.
- Align the door by sliding the hinge plate to the left or right.
- Then tighten screws ② again. Screw ① does not need to be used again.

To align the **upper door** use the long outer slots in the middle hinge plate:

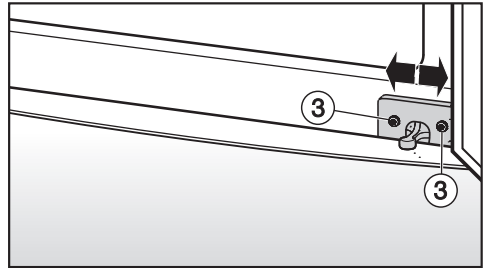

- Slightly loosen both screws ③.
- Align the door by sliding the hinge plate to the left or right.
- Then tighten screws ③.

Building in the appliance

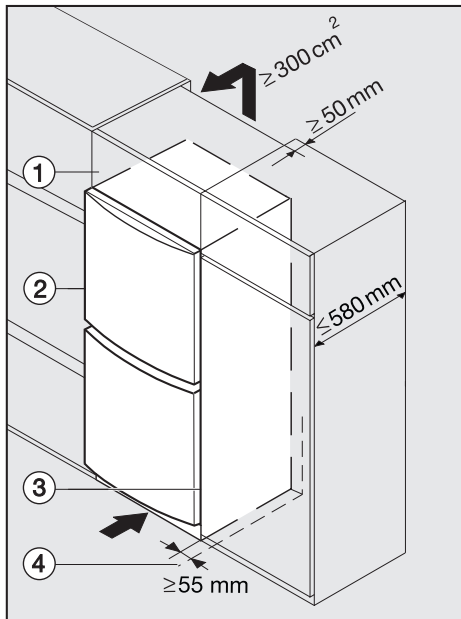

The air inlet and outlet must not be covered or blocked in any way. They should be dusted on a regular basis.

When built into a kitchen run (max. depth 580 mm) the appliance can be installed directly next to a kitchen furniture housing unit. The appliance door will protrude in front of furniture fronts at the sides by 34 mm and by 55 mm in the middle of the door. This enables the doors to be opened and shut without being obstructed.

When installed **next to a wall** (4) a distance of approx. 55 mm must be maintained on the hinge side between the wall (4) and the appliance (2), so that the doors and the handles have sufficient space for opening.

- ① Top box
- ② Appliance
- ③ Housing unit
- ④ Wall

The appliance can be installed in a kitchen run. To match the height of the rest of the kitchen, the appliance can be fitted with a suitable top box (1).

A ventilation gap of at least 50 mm depth must be allowed for behind the appliance across the entire width of the top box for air to circulate.

The cross section of the air outlet under the room ceiling must be at least 300 cm² to ensure that air can circulate without hindrance. Otherwise the appliance has to work harder, resulting in an increase in electricity consumption.

United Kingdom

Miele Co. Ltd.
Fairacres, Marcham Road
Abingdon, Oxon, OX14 1TW
Tel: 0845 365 0555
Fax: 0845 365 0777
Customer Contact Centre Tel: 0845 365 6600
E-mail: info@miele.co.uk
Internet: www.miele.co.uk

Australia

Miele Australia Pty. Ltd.
ABN 96 005 635 398
1 Gilbert Park Drive, Knoxfield, VIC 3180
Tel: 1300 464 353, Fax: (03) 9764 7149
Internet: www.miele.com.au

China

Miele (Shanghai) Trading Ltd.
1-3 Floor, No. 82 Shi Men Yi Road
Jing' an District
200040 Shanghai, PRC
Tel: +86 21 6157 3500
Fax: +86 21 6157 3511
E-mail: mieleshanghai@cn.miele.com
Internet: www.miele.cn

Miele (Hong Kong) Limited

41/F - 4101, Manhattan Place
23 Wang Tai Road
Kowloon Bay
Hong Kong
Tel: (852) 2610 1331
Fax: (852) 2610 1013
Email: mielehk@miele.com.hk

India

Miele India Pvt. Ltd.
Ground Floor, Copia Corporate Suites
Plot No. 9, Jasola
New Delhi - 110025
Tel: 011-46 900 000, Fax: 011-46 900 001
E-mail: customercare@miele.in
Internet: www.miele.in

Manufacturer: Germany - Miele & Cie. KG
Carl-Miele-Straße 29, 33332 Gütersloh

Miele

Ireland

Miele Ireland Ltd.
2024 Bianconi Avenue
Citywest Business Campus, Dublin 24
Tel: (01) 461 07 10, Fax: (01) 461 07 97
E-Mail: info@miele.ie, Internet: www.miele.ie

New Zealand

Miele New Zealand Limited
Unit L, 10-20 Sylvia Park Road
Mt. Wellington, 1060, Auckland, NZ
Tel: 0800 264 353, Fax: 0800 463 453
Internet: www.miele.co.nz

Singapore

Miele Southeast Asia
Miele Pte. Ltd.
163 Penang Road
04 - 02/03 Winsland House II
Singapore 238463
Tel: +65 6735 1191, Fax: +65 6735 1161
E-Mail: infosea@miele.com.sg
Internet: www.miele.sg

South Africa

Miele (Pty) Ltd
63 Peter Place, Bryanston 2194
P.O. Box 69434, Bryanston 2021
Tel: +27 (0) 11 548-1900
Fax: +27 (0) 11 548-1935
E-mail: info@miele.co.za
Internet: www.miele.co.za

United Arab Emirates

Miele Appliances Ltd.
P.O. Box 11 47 82
Gold & Diamond Park
Sheikh Zayed Road
Building 6 / Offices Nos. 6-214 to 6-220
Dubai
Tel: +971-4-341 84 44
Fax: +971-4-341 88 52
E-Mail: info@miele.ae
Internet: www.miele.ae

Alteration rights reserved / 0612

M.-Nr. 09 290 880 / 01

KFN 12943 SD edt/cs



Free Manuals Download Website

<http://myh66.com>

<http://usermanuals.us>

<http://www.somanuals.com>

<http://www.4manuals.cc>

<http://www.manual-lib.com>

<http://www.404manual.com>

<http://www.luxmanual.com>

<http://aubethermostatmanual.com>

Golf course search by state

<http://golfingnear.com>

Email search by domain

<http://emailbydomain.com>

Auto manuals search

<http://auto.somanuals.com>

TV manuals search

<http://tv.somanuals.com>