

# Miele

## Operating and installation instructions



Fridge freezer  
KFN 8992 SD ed  
KFN 8993 SDE ed

en - CA

To avoid the risk of personal injury or damage to the appliance, it is **essential that you read these operating instructions before installing the appliance or using it for the first time.**

M.-Nr. 06 926 030

# Contents

---

<b>Description of the appliance</b> . . . . .	4
<b>Caring for the environment</b> . . . . .	6
<b>Safety information and warnings</b> . . . . .	7
<b>How to save energy</b> . . . . .	11
<b>Switching the appliance ON and OFF</b> . . . . .	12
Refrigerator section . . . . .	12
Freezer section . . . . .	12
Safety lock . . . . .	13
Switching off for extended periods of time . . . . .	13
<b>The right temperature</b> . . . . .	14
Automatic cold air circulation (DynaCool) . . . . .	14
Setting the temperature in the refrigerator and freezer sections . . . . .	14
Temperature range . . . . .	15
Temperature displays . . . . .	15
Temperature display brightness . . . . .	16
Changing the temperature display . . . . .	16
<b>Alarm</b> . . . . .	17
Temperature alarm . . . . .	17
Door alarm . . . . .	17
Switching the alarm system ON . . . . .	17
Switching the alarm OFF early . . . . .	17
<b>Using Super Cool and Super Freeze</b> . . . . .	18
Super Cool . . . . .	18
Freezing fresh food . . . . .	18
Super Freeze . . . . .	19
<b>Using the refrigerator efficiently</b> . . . . .	20
Different storage zones . . . . .	20
Food that should not be stored in a refrigerator . . . . .	20
Storing food correctly . . . . .	21
Fruit and vegetables . . . . .	21
Unpackaged meat and produce . . . . .	21
High-protein foods . . . . .	21
Meat . . . . .	21
<b>Adjusting the interior fittings</b> . . . . .	22

<b>Freezing and storing food</b> . . . . .	23
Maximum freezing capacity . . . . .	23
Storing frozen food . . . . .	23
Home freezing . . . . .	23
Hints for home freezing . . . . .	23
Packing . . . . .	24
Before placing food in the freezer . . . . .	24
Placing food in the freezer . . . . .	24
Freezer calendar . . . . .	25
Marker system for frozen food . . . . .	25
Defrosting frozen foods . . . . .	25
Cooling drinks quickly . . . . .	26
Using the cool pack . . . . .	26
<b>Making ice cubes (may vary by model)</b> . . . . .	27
<b>Automatic defrosting</b> . . . . .	29
<b>Cleaning and care</b> . . . . .	30
Cleaning the exterior, interior and accessories . . . . .	30
Cleaning the ice cube tray* (*may vary by model) . . . . .	31
Cleaning the exterior coils . . . . .	31
Door seals . . . . .	31
Cleaning the exterior coils . . . . .	32
<b>Troubleshooting</b> . . . . .	33
<b>Noises</b> . . . . .	36
<b>After-sales service</b> . . . . .	37
<b>Plumbing (may vary by model)</b> . . . . .	38
Connecting to the water supply . . . . .	38
<b>Electrical information</b> . . . . .	40
<b>Installation information</b> . . . . .	41
Location . . . . .	41
Climate range . . . . .	41
Proper ventilation . . . . .	41
Installation . . . . .	41
Adjustments . . . . .	42
<b>Changing the door hinging</b> . . . . .	43
<b>Installing the appliance</b> . . . . .	46

# Description of the appliance

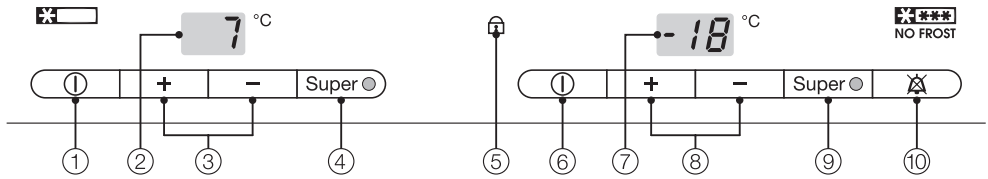

- ① ON/OFF button for the refrigerator section
- ② Temperature display for the refrigerator section
- ③ Temperature selector buttons for the refrigerator section (+ for warmer; - for colder)
- ④ Super Cool button and indicator light
- ⑤ Safety lock indicator light
- ⑥ ON/OFF button for the freezer section
- ⑦ Temperature display for the freezer section
- ⑧ Temperature selector buttons for the freezer section (+ for warmer; - for colder)
- ⑨ Super Freeze button and indicator light
- ⑩ Alarm button

# Description of the appliance

- ① Butter and cheese compartment
- ② Interior lighting
- ③ Dynamic cooling fan
- ④ Egg tray
- ⑤ Shelves
- ⑥ Door shelves
- ⑦ Condensate channel and drain hole
- ⑧ Bottle shelf
- ⑨ Produce bins
- ⑩ Bottle stand\*
- ⑪ Ice cube drawer with automatic ice cube maker\*
- ⑫ Freezer drawers with freezer calendar
- ⑬ Marker system for frozen food

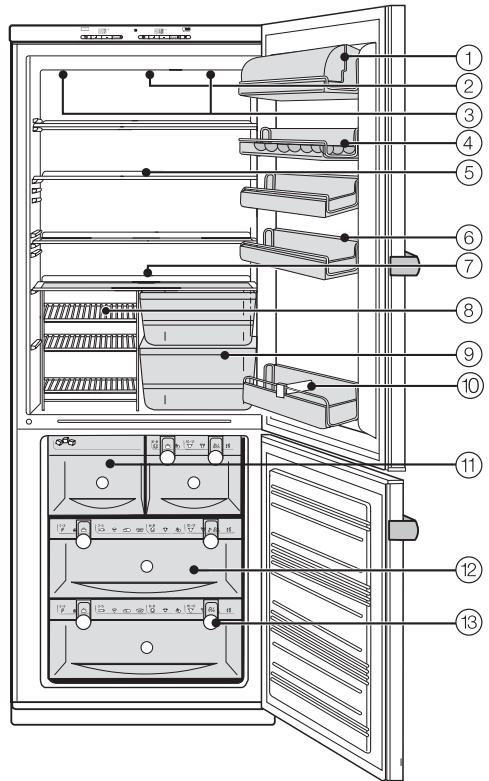

\* may vary by model

# Caring for the environment

---

## Disposing of the packing materials

The packing materials help protect the appliance during transport. They have been selected from environmentally responsible materials and are intended to be recycled.

By recycling, you help conserve raw materials and reduce waste. The packing materials can be returned to your dealer.

## Disposing of your old appliance

Even when you are ready to dispose of it, most electric and electronic equipment still contains useful materials that can be recovered. It may also contain harmful substances that were necessary for safe use. Improperly disposing of these items in your household waste can be harmful to your health and the environment. This is why it is important NEVER to dispose of your old appliance in your regular household waste.

Instead, please contact your local community waste collection and recycling centre for electric and electronic appliances.

While the appliance is being transported (or stored for transport), please take care not to damage the pipework at the back and bottom. By protecting the pipework, you help keep the coolants and compressor oil from contaminating the environment.

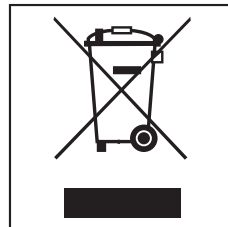

If the appliance is being stored for disposal, please make sure it poses no danger to children (remove the door, and store appliance on side to prevent tipping).

This appliance complies with all applicable safety laws and regulations. However, improper use can result in personal injury and material damage. These operating instructions contain important information on the safe installation, operation, and care of your appliance. To avoid the risk of personal injury or damage to the appliance, it is important that you carefully read the instructions. Keep them in a safe place and pass them on to any future user.

## Correct use

► This appliance is intended for domestic use only, specifically for the cool storage of food and drinks, for freezing fresh food, for storing frozen food, and for making ice. Any other use is not permitted, and could be dangerous. The manufacturer will not be held liable for damage caused by incorrect use of any kind.

## Technical safety

► This appliance contains the coolant R134a, which is an environmentally acceptable, non-flammable hydrofluorocarbon (HFC). It does not damage the ozone layer. For more information on the coolant, refer to the information plate posted on the inside of the refrigerator section. When transporting and installing the appliance, care must be taken not to damage any part of the cooling system. If damage does occur: - unplug the appliance from the socket, - air the room where the appliance is, for several minutes, - contact the Miele Service Department for advice.

► Before plugging in the appliance, you must make sure that the electrical rating (voltage and frequency, indicated on the model plate) corresponds to the household electrical supply. These ratings must match, in order to avoid damaging the appliance. If in doubt, please contact a qualified electrician.

► The electrical safety of this appliance can only be guaranteed when there is proper grounding that complies with applicable safety regulations. It is very important to make sure that this essential safety requirement is met. If there is any doubt about the grounding of your household wiring system, have it inspected by a qualified electrician. The manufacturer will not be held liable for damages resulting from an inadequate grounding system (for example, electric shock).

# Safety information and warnings

---

▶ Safe operation of the appliance is only assured if it has been installed and connected in accordance with these installation and operating instructions.

▶ To protect the refrigerator from possible damage, take care that it always remains in an upright position. Any time it is moved or installed, always let it stand for 30 to 60 minutes before plugging it in. This allows the coolant and lubricant to settle down, which is essential for proper operation.

▶ This appliance is not designed for use in non-stationary locations (for example, on ships). However, this use may be possible if a qualified specialist determines that the appliance can be used safely in the location in question.

▶ Only suitably qualified professionals should perform installation work, maintenance, and repairs on this appliance.

▶ To eliminate the risk of electric shock, one of the following conditions must apply:

- the appliance has been unplugged from the socket. To unplug, pull carefully on the plug, NOT on the cord.
- the main breaker for the house wiring system is completely shut off.
- the screw-out fuse is completely unscrewed and removed.

▶ Do not connect the appliance to the power supply by an extension cord.

Extension cords do not guarantee the required safety of the appliance (danger of overheating, for example).

## Water supply line (may vary by model)

▶ The manufacturer will not be held liable for damages resulting from a faulty water supply line connection.

▶ Only qualified professionals should connect the appliance to the household water line, or perform any repairs on the icemaker.

▶ The ice cube maker is not intended to be used with a hot water supply line.

▶ The fridge/freezer must be disconnected from the power supply before the appliance is connected to the household water line.

## Use

▶ Do not handle frozen items when your hands are wet. Your hands could freeze to the item(s). Danger - frost burn!

▶ Never put ice or popsicles in your mouth immediately after taking them out of the freezer - your lips or tongue could freeze to the item(s). Danger - frost burn!

▶ Never re-freeze partially or completely thawed food. Defrosted food should be used promptly, before it loses nutritional value or spoils. However, once it has been cooked, thawed food can be frozen again.

▶ Never store explosive materials in the appliance, or products with flammable propellants (spray cans, for example). Sparking can occur when the thermostat switches on, causing any flammable gasses to explode.



# Safety information and warnings

---

▶ Do not operate any electrical devices in the appliance (soft ice cream maker, for example). This could cause sparking. Danger of explosion!

▶ High proof alcohol should be stored upright, in tightly closed bottles in the refrigerator section. Danger of explosion!

▶ Do not store cans or bottles in the freezer that contain carbonated beverages or liquids that could freeze. The cans or bottles could explode. Danger of injury, and danger of appliance damage!

▶ Bottles that are put in the freezer for quick cooling must be removed within one hour. Otherwise, they could burst. Danger of injury, and danger of appliance damage!

▶ Eating food past the expiry date can cause food poisoning. Shelf life depends on many factors, including the quality of the food, how fresh it is, and the storage temperature. Always observe the manufacturer's recommended storage conditions and expiry dates.

▶ Never use a sharp-edged object to

- remove frost or ice,
- or to free frozen items or ice trays from the freezer.

This will damage the evaporator, causing irreversible damage to the appliance.

▶ Never place candles or electric heaters in the appliance to defrost it. This can damage the plastic parts.

▶ Do not use defrosting sprays or de-icers. They may contain substances that can damage the plastic, or that could cause a build-up of potentially explosive gasses and pose a danger to health.

▶ Do not use any oils or grease on the door seals, because they can cause the seals to deteriorate over time.

▶ If you store oily or greasy foods in the appliance, make sure that no oil or grease spills onto the plastic parts. This can cause the plastic to crack and break.

▶ Do not block the ventilation slits, because this interferes with proper air supply to the appliance. This in turn causes increased demand for electricity, and may also result in damage to appliance parts.

▶ The appliance is designed for use within a certain temperature range (room temperature), and should not be used outside this range. The climate range for your appliance is printed on the information plate inside the appliance. If the room temperature is too cold, this will cause the appliance to switch off for longer periods of time, with the result that it cannot maintain the required internal temperature.

▶ Never use a steam cleaner to defrost or clean the appliance. Pressurized steam could reach the electrical components and cause a short circuit.

# Safety information and warnings

---

## Disposing of your old appliance

- ▶ Before disposing of your old fridge/freezer, first make sure that the door latch or lock is unusable. This will prevent children from accidentally locking themselves in, which could place them at risk of death.
- ▶ Obsolete appliances should have the cable cut off and the plug made unusable.
- ▶ Take care not to damage any part of the cooling system, for example by
  - puncturing the coolant channels in the evaporator.
  - bending any pipework.
  - scratching the surface coating.

Caution: Coolant can cause eye damage - protect yourself from splashes.

The manufacturer will not be held liable for damage caused by failure to comply with the Safety information and warnings.

# How to save energy

	Normal energy consumption	Increased energy consumption
<b>Installation site</b>	In a well ventilated room.	In an enclosed, poorly ventilated room.
	Protected from direct sunlight.	In direct sunlight.
	Away from heat sources (radiator, stove/oven).	Near heat sources (radiator, stove/oven).
	When the room temperature is ideal (approx. 20 °C (68 F)).	When the room temperature is high.
<b>Temperature setting (dial)</b>	At a medium setting of 2 to 3.	At a high setting: The lower the temperature in the appliance, the more energy it consumes.
<b>Temperature setting (digital)</b>	Cellar compartment 8 to 12 °C (46 to 54 F)	On appliances with a winter setting, make sure that the winter setting is switched off when the room temperature is warmer than 16 °C.
	Refrigerator section 4 to 5 °C (39 to 41 F)	
	Freezer section -18 °C (-2 F)	
<b>Use</b>	Open the door only when necessary, and for as short a time as possible.	Frequent opening of the door for long periods will cause a loss of coldness.
	Store food in an organized way.	Disorganized contents will take time to sort through, leaving the door open too long.
	Allow hot food and drinks to cool down before placing them in the appliance.	Placing hot food in the appliance will cause the compressor to run for a long time, with the appliance working harder to lower the temperature.
	Store food covered or packaged.	The evaporation or condensation of liquids will cause a loss of coldness in the refrigerator.
	Place frozen food in the refrigerator to defrost.	
	Do not overfill the appliance. Leave some room so that air can circulate properly.	
<b>Defrosting</b>	Defrost the freezer when a layer of ice 1 cm thick has built up.	A layer of thick ice hinders cold air from reaching the frozen food, and causes an increase in energy consumption.

# Switching the appliance ON and OFF

## Before using for the first time

The stainless steel surfaces and trim are covered in a protective sheeting for transport.

- Do not remove the sheeting until the appliance has been installed in its final location. To peel the sheeting off, start at one of the upper corners.
- Next, coat the stainless steel surfaces with a special stainless steel product (which is available through customer service).
- Clean the inside of the appliance and the accessories with warm water and some mild soap. Dry with a soft cloth.

It is very important to let the appliance stand for 30 to 60 minutes after transport before you plug it in for the first time. Failure to do so can prevent the appliance from functioning properly!

## Switching the appliance ON

The refrigerator and freezer sections can be switched on separately, so that you can choose which sections you want on at a given time.

### Refrigerator section

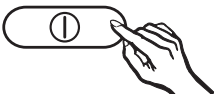

- Press the ON/OFF button for the refrigerator section.

You will see the temperature display for the refrigerator section come on. The refrigerator will now start cooling, and

the interior light will come on when you open the door.

### Freezer section

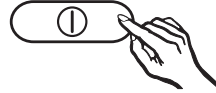

- Press the ON/OFF button for the freezer section.

You will see flashing bars in the temperature display for the freezer section, which will now start cooling.

Allow the appliance to run for a few hours before placing food in it. This will ensure that the temperature is sufficiently low.

## Cool pack

Place the cool pack in the top drawer of the freezer section or, to save space, on the freezer tray (may vary by model). The cool pack will be at its most effective after it has been in the freezer for approximately 24 hours.

## Switching the appliance OFF

- Press each ON/OFF button, so that the temperature display goes out.

The cooling process is now switched off. If this does not happen, then the safety lock is engaged.

# Switching the appliance ON and OFF

## Safety lock

The safety lock can be activated to prevent the appliance from being switched off inadvertently.

### Activating and deactivating the safety lock

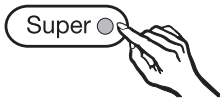

- Hold down the superfreeze button for approx. 5 seconds.

The indicator light for the superfreeze button flashes and the temperature display shows **⊞**.

- Now press the superfreeze button again.

The display will show **⊞**.

- Now, by pressing the set temperature buttons, you can choose between **⊞** and **⊞ 1**:
  - ⊞ Safety lock is deactivated,
  - ⊞ 1: Safety lock is activated.

- To save the setting, press the super freeze button.

When the safety lock is activated, the safety lock indicator light will read .

- To exit from set mode, press the ON/OFF button for the freezer section. Otherwise it will automatically revert to normal mode in approx. 2 minutes.

## Switching off for extended periods of time

If the appliance is not needed for a longer period of time (such as when you are away on holiday), then:

- switch the appliance off,
- unplug it from the socket,
- close the shut-off valve (may vary by model),
- clean the appliance out, and
- leave the doors ajar, to air the appliance.

If, in preparation for longer absences, you fail to clean the appliance and leave the doors ajar, there is the risk of mould and odours building up in the appliance.

# The right temperature

---

It is important to set the right temperature for storing food in the appliance. If food is not stored at the right temperature, bacteria can multiply rapidly, causing the food to spoil. This can be prevented by selecting the right temperature. Temperature affects the rate at which bacteria can multiply, and reducing the temperature can slow down this process.

The temperature in the appliance will rise for the following reasons:

- if you open the door frequently, or keep it open too long,
- if you put too much food in it,
- if you put food in it that is too warm,
- if the room temperature is too high. The appliance is designed for use within a certain temperature range (room temperature), and should not be used outside this range.

## ... in the refrigerator

We recommend a temperature of **4 °C (39 F)** in the refrigerator section.

### Automatic cold air circulation (DynaCool)

Whenever the refrigerator section switches on for cooling, the fan is automatically switched on as well. This ensures that cold air is evenly distributed throughout the refrigerator, so that all the food stored inside will be chilled to approximately the same temperature.

## ... in the freezer

For freezing fresh food and storing frozen food for longer periods of time, the temperature needs to be at least **-18 °C (0 F)**. At this temperature, most bacteria stop growing. However, if the temperature rises above -10 °C (14 F), the bacteria can become active, which will make the food start to deteriorate. This is why any partially or completely thawed food must never be refrozen until it has been cooked. High cooking temperatures will kill most bacteria.

## Setting the temperature in the refrigerator and freezer sections

The temperatures for the refrigerator section and the freezer section are set independently, using the buttons to the right and left of the temperature displays.

Press the



+ button: to increase the temperature (it gets warmer)

- button: to decrease the temperature (it gets colder)

The temperature being set will flash in the display.

When you press the buttons, you will see the following changes in the display:

- When first pressed: The **last temperature selected flashes**.
- Each subsequent press of the button: adjusts the temperature in increments of 1 °C / 1 F.
- Holding down the button will continue to adjust the temperature.

Approximately 5 seconds after you release the button, the current **actual temperature of the refrigerator or freezer will automatically be shown**.

If you have changed the temperature, you will need to wait approx. 6 hours if the appliance is not very full, or approx. 24 hours if it is full, before checking the temperature display again, because it will take this long for the display to show an accurate temperature. If, after this amount of time, the temperature is too high or too low, you will need to adjust it again.

## Temperature range

The temperature can be selected from within the following ranges:

- in the refrigerator section from 2 °C to 11 °C (36 to 52 F)
- in the freezer section from -14 °C to -26°C (8 to -15 F)

The room temperature and the installation location can affect the time it takes for the appliance to drop to the coldest temperature. If the room temperature is too high, it may not be

possible for the appliance to reach the lowest temperature.

## Temperature displays

During normal operation, the temperature display shows the temperature in the middle of the refrigerator section and the temperature in the warmest part of the freezer section.

If the temperature in the appliance is not within the range that the appliance is able to display, (below 0 °C (32 F) for the refrigerator section; above 0 °C (32 F) for the freezer), you will see flashing bars in the temperature displays.

The **temperature displays flash** under the following conditions:

- whenever a different temperature is being set,
- whenever the temperature in the appliance has risen by several degrees, indicating that the appliance is warming up too much.

This short-term loss of cooling is no cause for concern in the following cases:

- when the door has been left open for a while, for example to take out or put in a large amount of food,
- when fresh food is being frozen.

# The right temperature

However, if the temperature remains above -18 °C (0 F) for a longer period of time, you will need to check to make sure that any frozen food has not started to defrost. Any food that has started to thaw must be used as soon as possible!

## Temperature display brightness

When the appliance is delivered, the default brightness for the temperature display is on the lowest setting. Whenever the door is opened or the alarm is triggered, the temperature display will become very bright for approx. 1 minute.

You can adjust the brightness as follows:

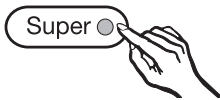

- Hold down the superfreeze button for approx. 5 seconds.

The indicator light for the superfreeze button flashes and the temperature display shows **c**.

- Keep pressing one of the set temperature buttons until you see **h** in the display.
- Now press the superfreeze button again.

The display will show **h**.

- Now you can use the set temperature buttons to adjust the brightness of the display. You can choose a brightness level from **1** to **5**, where **1** is the least bright, and **5** is the most bright.

- To save the setting, press the super freeze button.
- To exit from set mode, press the ON/OFF button for the freezer section.

Otherwise, it will automatically return to normal mode after approx. 2 minutes.

## Changing the temperature display

The temperature can be displayed in either Celsius or Fahrenheit. When the appliance is switched on for the first time, or after a power failure, the temperature display and setting display for the refrigerator will show the **set** temperature for five seconds, in either degrees Celsius or degrees Fahrenheit. After this, the **actual** temperature is displayed.

## Changing the temperature display (Celsius/Fahrenheit):

To change the temperature display,

- hold down **both** the alarm button and the down button for the refrigerator temperature, for seven seconds.

The set temperature display will blink six times.

- Now, while the temperature display is blinking, hold down the alarm button and use the down button for the refrigerator temperature to change the temperature display (Celsius or Fahrenheit).

Once you have changed the selection, the temperature display will blink six times. Then both temperature displays will show the **actual** temperature.



The appliance is equipped with an alarm system to ensure that the temperature in the freezer section does not rise unnoticed, and to avoid energy being wasted if the door is left open.

## Temperature alarm

If the temperature becomes too warm, an alarm will sound and the temperature display will flash. The temperature the appliance is set at will determine when the alarm is triggered.

The alarm will sound and the display will flash under the following conditions:

- whenever too much warm air flows into the appliance, for example when food is being loaded, re-arranged, or taken out.
- whenever large amounts of food are being frozen at once.
- whenever there has been a lengthy interruption of the power supply.

## Door alarm

If the appliance door is left open for longer than approx. 60 seconds, the alarm signal will sound.

## Switching the alarm system ON

The alarm system is always active. It does not need to be switched on manually.

## Switching the alarm OFF early

Once the set temperature has been reached in the freezer section, the alarm signal stops and the temperature display stops blinking. If the alarm signal bothers you, it can be switched off early.



- Press the alarm off button. The alarm signal will stop. The temperature display will continue to blink until the set temperature has been reached. The display then stops blinking, and shows a steady reading. At this point, the alarm system is ready again if needed.

# Using Super Cool and Super Freeze

---

## Super Cool

The Super Cool function can be used to rapidly reduce the temperature in the refrigerator section to its lowest setting (depending on the room temperature).

### Switching Super Cool ON

Super Cool is particularly recommended for faster chilling of large amounts of fresh food or drink.

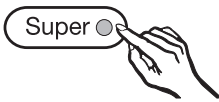

- Press the Super Cool button, and the indicator light will come on. The appliance will now work at full power to lower the temperature in the refrigerator section.

### Switching Super Cool OFF

The Super Cool function automatically switches off after approx. 6 hours. The indicator light turns off, and the appliance continues running at normal power.

To save energy, the Super Cool function can be switched off once the food and/or drinks are sufficiently chilled.

- Press the Super Cool button, and the indicator light will now go out.

The appliance now continues running at normal power.

## Freezing fresh food

Fresh food should be frozen as quickly as possible, so that the nutritional value, vitamin content, appearance, and taste are retained.

When food takes a long time to freeze, water leaks out of the cells, which then shrink. Later, when the food is defrosted, only a portion of this water is reabsorbed into the cells. This means that slowly frozen food loses a lot of its moisture. You can recognize this if a large pool of water collects around the food as it thaws.

By contrast, if the food is frozen quickly, the cells have less time to lose moisture, so they shrink less. Also, because a smaller amount of moisture is lost, it is easier for the food to reabsorb it during the defrosting process. This can be recognized by the relatively small pool of water around the food.

# Using Super Cool and Super Freeze

---

## Super Freeze

For best results, switch on the Super Freeze function before putting fresh food into the freezer.

### Exceptions:

- if you are loading frozen food into the freezer.
- if you are not loading more than 2kg fresh food into the freezer per day.

## Switching Super Freeze ON

The Super Freeze function should be switched on **6 hours before** you wish to place small to medium quantities of fresh food in the freezer. However, if you are planning to load the **maximum amount of food** into the freezer, the Super Freeze function should be switched on **24 hours beforehand**.

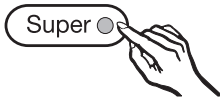

- Press the Super Freeze button on the right, and the indicator light will come on. The appliance will now work at full power to lower the temperature in the freezer section.

## Switching Super Freeze OFF

Depending on the amount of food placed in the freezer, the Super Freeze function will automatically switch off after approx. 30 to 60 hours. The indicator light turns off, and the appliance continues running at normal power, which saves energy.

# Using the refrigerator efficiently

---

## Different storage zones

The natural circulation of air throughout the appliance creates different temperature zones in the refrigerator. Cold air is heavier, so it sinks to the lowest section of the appliance. Take advantage of these different zones when you choose where to place food in the appliance.

### Warmest area

The warmest area is in the top section of the door. You can use this area to store butter (to keep it spreadable), and cheese (to keep its flavour).

### Coldest area

The coldest area in the refrigerator is directly above the vegetable containers.

Use this for all delicate and highly perishable food, such as:

- fish, meat, poultry,
- deli meats, store-bought meals,
- dishes or baked goods containing eggs or cream,
- fresh bread dough, pastry dough, cake batters,
- raw milk cheeses and other raw milk dairy products,
- pre-packed vegetables and other fresh food with a best-before label that specifies a temperature of at least 4 °C (39 F).

Never store explosive materials in the appliance, or products with flammable propellants (spray cans, for example). Danger of explosion! If you store oily or greasy foods in the appliance door, make sure that no oil or grease spills onto the plastic parts. This can cause the plastic to crack and break. Do not allow food to touch the rear wall of the appliance, because it may freeze to the wall.

## Food that should not be stored in a refrigerator

Some foods are not suitable for storing in the refrigerator. Here are some examples:

- Fruit and vegetables that are sensitive to cold, such as bananas, avocados, papaya, passion fruit, eggplant, peppers, tomatoes, and cucumbers.
- Fruit that is not yet ripe.
- Potatoes.
- Some hard cheeses (for example, Parmesan).

# Using the refrigerator efficiently

---

## Storing food correctly

Store food covered or packaged. This will prevent smells or tastes from affecting other foods. It will also keep foods from drying out, and will help prevent cross-contamination of any bacteria. The growth of bacteria, such as salmonella, can be avoided by setting the correct temperature and maintaining good standards of hygiene.

## Fruit and vegetables

Fruit and vegetables can be stored loose in the vegetable bins. However, you should bear in mind that some types of vegetables give off a natural gas that speeds up ripening and spoiling. Other fruit and vegetables react strongly to this natural gas, and should not be stored together in the same bin.

### **Some fruits that produce a large amount of this natural gas are:**

Apples, apricots, pears, nectarines, peaches, plums, avocados, and figs.

### **Some fruits and vegetables that react strongly to this natural gas given off by other fruits and vegetables are:**

Kiwis, broccoli, cauliflower, brussel sprouts, mangoes, honeydew melon, apples, apricots, cucumbers, tomatoes, pears, nectarines, and peaches.

## Unpackaged meat and produce

Unpackaged meat and produce should be separated. If you plan to store them together, they should be packaged before being placed in the appliance. This helps to prevent contamination.

## High-protein foods

Please note that high-protein foods spoil more quickly. This means that shellfish spoils faster than fish, and fish spoils faster than meat.

## Meat

Meat should be stored unpackaged (with the wrappers/containers open.) This will cause the surface to dry, which helps control germs and keeps the meat fresher longer. Also, make sure to keep different types of meat in separate containers - they should not come in contact. This will help prevent cross-contamination and spoiling.

# Adjusting the interior fittings

---

## Moving the shelves

The shelves can be adjusted according to the height of the food.

- Lift the front of the shelf upward, pull the shelf out halfway, then move it upward or downward to remove it.
- With the rear barrier facing upwards, place the shelf at the desired position. The rear barrier must face upwards to prevent food from touching the back of the appliance and freezing to it.

## Split shelf

In order to accommodate tall items in the appliance, one of the shelves is divided. The front section can be gently pushed under the rear section.

- Lift the front half of the glass shelf slightly, then slide it carefully under the rear half.

## Adjusting the door shelves / bottle shelf

- Push the door shelf / bottle shelf upward, then remove it by pulling it forward.
- Replace the door shelf / bottle shelf at the desired position. Make sure that it is securely pushed back into position.

## Adjusting the bottle divider

(may vary by model)

The bottle divider can be moved to the left or right, to ensure that bottles are held securely in position when the door is opened and shut.

## Maximum freezing capacity

To ensure that fresh food placed in the freezer freezes through to the core as quickly as possible, the maximum freezing capacity must not be exceeded. The maximum freezing capacity within a 24-hour period is listed on the model plate, as "Freezing capacity ...kg/24 h".

## Storing frozen food

When buying frozen food to store in your freezer, make sure to check:

- that the packaging is not damaged,
- the expiry date
- the temperature at which the frozen food is being stored by the shop. If the food is being stored at a temperature warmer than  $-18\text{ }^{\circ}\text{C}$  ( $0\text{ }^{\circ}\text{F}$ ), this reduces the length of time it can be kept.
- Buy frozen food at the very end of your shopping trip, and wrap it in newspaper or use a cool box or bag to transport it.
- Place frozen food in the freezer immediately upon returning home.

Never re-freeze partially or completely defrosted food. However, once defrosted food has been thoroughly cooked, you may freeze it again.

## Home freezing

Only freeze food that is fresh and in good condition.

### Hints for home freezing

- The following types of food **are suitable** for home freezing: fresh meat, poultry, game, fish, vegetables, herbs, fresh fruit, dairy products, baked goods, leftovers, egg yolks, egg whites, and most pre-cooked meals.
- The following types of food **are not suitable** for freezing: grapes, lettuce, radishes, sour cream, mayonnaise, eggs in the shell, onions, whole raw apples and pears.
- To retain colour, taste, and vitamin C, vegetables should be trimmed, washed, and blanched. To blanch, immerse the vegetables in rapidly boiling water for 2 to 3 minutes. This can be done in small batches if you prefer. Remove (with a slotted spoon or colander) and plunge into a bowl or pot of ice water to cool quickly. Transfer to a colander and drain, then pack for freezing.
- Lean meat freezes better than fatty meat and can be stored for considerably longer.
- To prevent chops, cutlets, and steaks from sticking together in solid blocks, separate them with a sheet of plastic freezer film, parchment paper, or wax paper.

# Freezing and storing food

---

- Do not salt or season raw foods or blanched vegetables before freezing. Cooked food may be seasoned lightly before freezing, but note that some spices change taste when frozen.
- Do not place very warm or hot foods in the freezer. This causes already frozen food to thaw, and considerably increases energy consumption.

## Packing

- Freeze food in portions.

### **Suitable packing materials are:**

plastic freezer film, freezer bags (polyethylene), aluminum foil, freezer containers.

### **Unsuitable packing materials are:**

kraft paper, parchment paper, cellophane, garbage bags, plastic shopping bags.

- Expel as much air as possible from the package before sealing, to help prevent freezer burn on the food.
- Close the packaging tightly, with: rubber bands, plastic clips, string, bag ties, or freezer tape. Polyethylene freezer bags can also be sealed using home sealing kits.
- Mark the package to indicate the contents and the date of freezing.

## **Before placing food in the freezer**

- When you are planning to freeze large amounts of fresh food (more than 2kg), switch on the super freeze function ahead of time (see the instructions for "super freeze").

## **Placing food in the freezer**

Food to be frozen can be placed anywhere in the freezer section, but the upper drawer is preferable.

Larger items or quantities can be placed directly on the glass shelves, where they will freeze more quickly, which gives better results. To free up the shelves, the freezer drawers can be removed.

Each freezer drawer and glass shelf has a maximum load capacity of 25kg.

- Spread the food to be frozen across the entire bottom of the freezer drawer or across the glass shelves, so that it will freeze through to the core as quickly as possible.
- When placing items in the freezer, make sure the packaging and containers are dry, to keep them from sticking together when frozen.



# Freezing and storing food

When freezing, make sure that already frozen food does not come into contact with fresh food being frozen, because this could cause the frozen food to begin to defrost.

## Freezer calendar

The freezer calendar on the freezer drawer lists the maximum recommended storage times for various types of fresh-frozen food.

However, for packaged foods, you should follow the best-before recommendations listed on the wrapper.

## Marker system for frozen food

Markers help remind you how long food has been stored.

Each freezer drawer has two slide markers with dials. The months from 1 to 12 are marked on the dials.

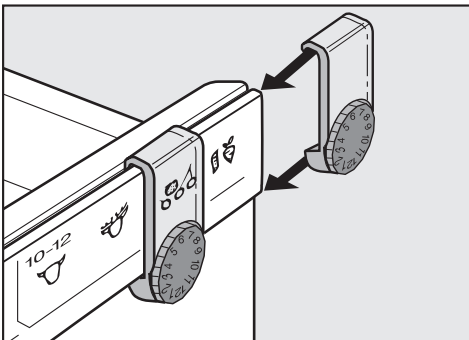

- From the edge of each drawer, slide the markers onto the guide runners.

Use the markers to indicate the type of food being frozen, and turn the dial to

indicate the month the food was first placed in the freezer.

## Defrosting frozen foods

Frozen food can be defrosted in different ways:

- in a microwave,
- in a regular oven, using the "fan" or "defrost" setting,
- at room temperature,
- in the refrigerator (as it thaws, the frozen food will help cool the other food in the refrigerator),
- in a Miele Steam Oven.

**Flat pieces** of partially thawed meat or fish can be placed directly into a hot pan.

Fruit can be thawed at room temperature, either in the packaging or in a covered bowl.

**Most vegetables** can be cooked while still frozen. You can place them directly in simmering water or hot oil. Because of changes to the cell structure, the cooking time is slightly shorter than for fresh vegetables.

Never re-freeze partially or completely defrosted food. However, once defrosted food has been thoroughly cooked, you may freeze it again.

# Freezing and storing food

---

## Cooling drinks quickly

To cool drinks quickly, switch on the super cool function. If you choose to place them in the freezer instead, do not leave them in longer than **1 hour**, or they could burst.

## Using the cool pack

The cool pack prevents the temperature in the freezer from rising too quickly in the event of a power cut.

Place the cool pack in the upper drawer directly on top of food. The cool pack will be at its most effective after it has been in the freezer for approximately 24 hours.

If there is a power cut, place the cool pack directly on top of the frozen food in the upper drawer, to help keep the food cold for as long as possible.

When placing fresh food in the freezer, use the cool pack to separate the fresh food from the already frozen food, so that the frozen food does not begin to thaw.

The cool pack can also be used in a cool bag, to keep food or drinks cool for a short period of time.

# Making ice cubes (may vary by model)

For the automatic ice cube maker to operate, it must be connected to the household water line.

## Switching the ice cube maker ON

- Switch the freezer ON.
- Open the top left drawer in the freezer section.

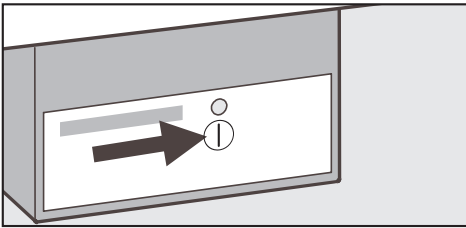

- Press the ON/OFF button, and the indicator light will now come on.
- Close the drawer.

The drawer must be completely shut for ice cubes to be produced.

After the appliance is turned on for the very first time, it can take up to 24 hours for the first ice cubes to drop out of the ice cube maker and collect in the drawer. Thereafter, when the ice cube maker is switched off and then on again it will take a maximum of 6 hours for ice to be produced.

To ensure that the water pipes are thoroughly flushed through, you must not consume the first three batches of ice from the ice maker. This applies not only when the appliance is first being used after installation, but also if it has been out of use for a longer period of time (for example, after being away on holiday).

## Making a large amount of ice cubes

The amount of ice cubes made depends on the temperature in the freezer section. The lower the temperature, the more ice cubes are produced within a given period of time. Once the ice cube drawer is full, ice cube production is automatically halted.

If you require a large amount of ice cubes,

- replace the full ice cube drawer with the drawer beside it on the right.

Once the empty drawer has been placed in position and closed properly, the ice cube maker will begin to produce new ice cubes again.

## Making ice cubes (may vary by model)

---

### Switching OFF the ice cube maker

If you do not want the appliance to make any ice cubes, the ice cube maker can be switched off independently of the freezer section.

- Press the ON/OFF button on the ice cube maker, and the indicator light will now come on.

If the ice cube maker is switched off, the ice cube drawer can be used as an extra drawer for freezing fresh food or storing frozen food.

## Refrigerator section

During normal operation, condensate and frost can form on the back wall of the refrigerator section. These are automatically removed by the appliance during automatic defrosting.

The condensate is drained away through a channel and drain hole, then fed into an evaporation system at the back of the appliance.

It is important to keep the condensate channel and drain hole clean and free of blockages, so that the condensate can flow away properly.

## Freezer section

The freezer is equipped with a "frost-free" system, which automatically defrosts the freezer section as needed, to prevent build-up.

The moisture generated in the appliance collects on the condenser, and is automatically defrosted and evaporated periodically.

This automatic defrosting system keeps the freezer section permanently ice-free, while ensuring that the food stored in the freezer section does not defrost.

# Cleaning and care

---

Never use abrasive cleaners on the appliance, or products that contain acids, bases, or chemical solvents. Note that "non-abrasive" cleaners are also unsuitable, because they can cause matte patches to appear. For all stainless steel surfaces, use a special product (which is available through customer service). Make sure that no water gets into the electronic unit or into the light. Do not let any cleaning water get into the condensate channel or drain hole. Do not use a steam cleaner to clean the appliance. Steam could reach the electrical components and cause a short circuit. Never remove the model plate inside the appliance. It contains important information that is required in the event of a service call.

## Before cleaning

- Use the on/off button to switch the appliance off, then unplug it completely from the socket.
- Take any food out of the appliance and store it in a cool place.
- Take out any removable parts, so that they can be cleaned.
- Before cleaning the refrigerator shelves, first remove the stainless steel trim from the front side.

## Cleaning the exterior, interior and accessories

Use lukewarm water with some mild dish liquid. The accessories and shelves should all be cleaned by hand, except for the butter dish, which is dishwasher-safe.

- Clean the appliance at least once a month.
- Clean the condensate channel and drain hole in the refrigerator frequently, so that condensate can drain away properly. You can use a straw or similar item, for example.
- Use a special product to clean the stainless steel surfaces.
- After washing, wipe down the interior and accessories with a clean wet cloth, then dry with a soft cloth. Leave the appliance doors open for a short while, so the moisture can evaporate.

## Cleaning the ice cube tray\* (\*may vary by model)

Before the ice cubes drop down into the drawer, they are formed in an ice cube tray.

This tray should be cleaned regularly, to remove any stale ice or water.

- Connect the appliance to the power supply.
- Press the on/off button, and the indicator light will now come on.
- Empty the ice cube drawer.
- Hold down the on/off button for the ice cube maker for approx. 10 seconds (after approx. 1 second the ice cube maker will switch off and the indicator light will go out).

The indicator light will now flash.

- Within the next 60 seconds, push the ice cube drawer in as far as it will go.

This will cause the ice cube tray to rotate into an angled position, which makes it easier to clean.

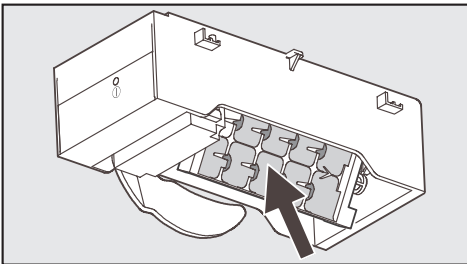

- Wait until the rotation has stopped before continuing.
- Now take the ice cube drawer out of the appliance.

- Clean the ice cube drawer and the ice cube tray with warm water and some mild dish liquid.

- Press the ON/OFF button for the ice cube maker.

The ice cube tray will now return to its original position.

- Now put the ice cube drawer back in the appliance and close it.

The ice cube maker will begin to produce ice cubes again within 6 hours.

If the ice cube maker has not been used for a longer period of time, it is important to clean it before making ice.

## Cleaning the exterior coils

- The ventilation slits should be cleaned on a regular basis, with a brush or vacuum cleaner. A build-up of dust will increase the amount of energy the appliance consumes.

## Door seals

Do not use any grease or oil on the door seals, because they will cause the seals to deteriorate over time.

The door seals should be cleaned regularly with clean water and then wiped dry with a soft cloth.

# Cleaning and care

---

## Cleaning the exterior coils

The metal coils on the back of the appliance (heat exchanger) need to be dusted and cleaned at least once a year. A build-up of dust and grime will increase the amount of energy the appliance consumes.

When cleaning the coils, be careful not to tear off, bend, or otherwise damage any wiring or other parts.

## After cleaning

- Return all shelves and accessories to the refrigerator section.
- Return food to the refrigerator section, close the doors, and switch both the refrigerator and freezer sections on.
- Switch on the super freeze function, so that the freezer section can cool down quickly. The indicator light will now come on.
- Once the temperature in the freezer section is cold enough, you can place the food in the freezer drawers and return the drawers to the freezer.
- The super freeze function can now be turned off, by pressing the super freeze button. The indicator light will now go out.



Repairs to electrical appliances should only be carried out by qualified professionals. Work performed by unqualified persons can place the user at considerable risk of harm.

Certain minor problems can be corrected without contacting the Miele Service Department.

## What should I do if ... . .

### . . . the refrigerator or freezer section does not get cool?

- Check that the section is switched on. The corresponding temperature display should be lit up.
- Check that the plug is correctly inserted in the socket.
- Check whether the main breaker for the house wiring system has blown a fuse. If so, contact the Miele service department.

### . . . the door to the freezer section will not open, because it has been opened and closed too many times in succession?

This is no cause for concern. Repeated opening and closing of the door can cause strong suction. Simply wait a few minutes, then try again. The door should now open without difficulty.

### . . . the temperature in the refrigerator or freezer section is too cold?

- Select a warmer temperature.
- You may have forgotten to switch off the super freeze or super cool function. The corresponding indicator light will still be on.

### . . . the appliance is switching on too frequently and for too long?

- Check whether the vents are blocked or dusty/dirty.
- Check whether the metal coils (heat exchanger) at the rear of the appliance are dusty/dirty.
- the doors have been opened too frequently, or a large amount of fresh food has been put in at once for freezing.
- Check that the doors are closing properly.

### . . . food has frozen together?

Use a blunt instrument (such as a spoon handle) to carefully pry the items apart.

### . . . the alarm signal sounds and the temperature display for the freezer section is flashing?

The freezer section temperature has risen above the set temperature, because:

- The freezer door has been opened too frequently, or a large amount of fresh food has been put in at once for freezing.

# Troubleshooting . . .

---

- the ventilation slits are blocked.
- there has been a lengthy interruption of the power supply.

Once the temperature is sufficiently low, the freezer section temperature display will return to a steady light and the alarm signal will stop sounding.

## **. . . a bar is lit up or flashing in the temperature displays?**

The temperature displays will not show a temperature until approximately 6 hours after the appliance has been switched on. It can take this length of time before the temperature reaches a level that can be displayed. Wait and check again.

## **. . . one of the messages "F1" to "F5" appears in the temperature display?**

This indicates a problem. Call the service department.

## **. . . "nA" appears in the temperature display?**

The temperature in the freezer section has risen too high at some point during the past few hours or days, because of a power cut.

- While "nA" is lit up in the display, press the alarm button. The temperature display will show the warmest temperature recorded in the freezer section during the power cut.

Depending on the temperature displayed, you should check the condition of the food in the freezer. Food that is defrosted (whether partially

or completely) must NOT be re-frozen until it has been thoroughly cooked.

The warmest recorded temperature will appear in the display for approx. 1 minute. After this, the display will revert to the actual current temperature in the freezer section.

## **. . . the super freeze or super cool indicator light is not lit up, even though the appliance is working?**

The indicator light is defective. Call the service department.

## **. . . the appliance cannot be switched off?**

The safety lock has been activated.

## **. . . the ice cube maker will not switch on?\* (may vary by model)**

- Check that the appliance is connected to the power supply.

## **. . . the ice cube maker is not producing any ice cubes? \* (may vary by model)**

- Was the water supply line purged of air by a qualified technician before the appliance was used for the first time?
- Check that the ice cube maker is switched on.
- Check that the freezer section is switched on.
- Check that the water supply line is open.
- Check that the ice cube drawer is properly closed.

# Troubleshooting . . .

Remember that it can take up to 24 hours for the first ice cubes to be produced.

## . . . the indicator light on the ice cube maker is flashing? \* (may vary by model)

This indicates a problem. Call the service department.

## . . . the interior light is not working?

- Was the refrigerator section door left open for too long? The lighting automatically switches off after the door has been open for approx. 15 minutes.

The light uses 2 light bulbs, which are located behind a cover, high in the refrigerator section. If the bulbs are defective, take the following steps:

- Unplug the appliance, or turn off the main breaker for the house electrical supply.

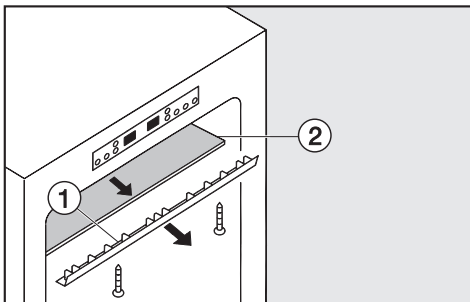

- Unscrew the retaining rail ①, then pull it forward and off.
- Carefully remove the glass plate ②.

- Unscrew the defective light bulb and replace it with a new one. Light bulb specification:  
115 V, max. 25 W, E 14 screw base.

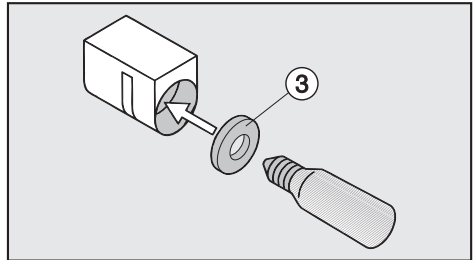

- Screw the new bulb into the socket. Ensure that it goes in correctly and that the seal ③ forms a tight fit.
- Now carefully re-insert the glass plate and re-attach the retaining rail.

## . . . the floor of the refrigerator is wet?

The drain hole is blocked.

- Clean the condensate channel and the drain hole.

If an error cannot be corrected using this problem solving guide, please contact the Miele Service Department. To prevent the unnecessary loss of temperature, it is recommended that you not open the appliance doors while waiting for the technician to arrive.

# Noises

<b>Normal noises</b>	<b>What causes them?</b>
<b>Brrrrr...</b>	Humming noise made by the motor (compressor). This noise may get louder for brief periods, whenever the motor kicks in.
<b>Blubb, blubb....</b>	A gurgling noise can be heard when coolant is circulating through the pipes.
<b>Click....</b>	Clicking sounds occur whenever the thermostat switches the motor on or off.
<b>Sssrrrrr....</b>	In multi-zone and frost-free appliances, the movement of air circulating through the appliance can sometimes just barely be heard.

Please bear in mind that a certain amount of noise is unavoidable (from the compressor, and the coolant circulating through the system).

<b>Noises that you can easily rectify</b>	<b>What causes them, and what can you do about them?</b>
<b>Rattling, vibrating</b>	The appliance is uneven: Balance the appliance using a level, and by raising or lowering the screw feet underneath the appliance, or placing something underneath them.
	The appliance is touching another appliance or piece of furniture: Move it away.
	Drawers, baskets, or shelves are unstable or sticking: Check all removable items and refit them correctly.
	Bottles or containers are unstable or knocking against each other: Separate them.
	The transport cable clips are hanging loose at the back of the appliance: Remove the clips.

In the event of a fault that you cannot correct yourself, or if the appliance is under guarantee, please contact:

– your Miele Dealer

or

– the Miele Service Department (see back cover for address).

When contacting your Dealer or the Service Department, please quote the model and serial number of your appliance. This information is shown on the data plate.

Please note that telephone calls may be monitored and recorded for training purposes.

## Plumbing (may vary by model)

The machine must be connected to the water supply by a licensed plumber in accordance with local and national regulations. The water being used should have the drinking water standards of the respective country where the machine is used.

- All units and systems used to deliver the water to the appliance must conform with the requirements of the respective country.
- The machine is designed to be plumbed to a cold water connection.
- The on-site water line must have a water valve to turn the water off if needed. If not present, have a water valve installed by a licensed plumber.
- The water valve must be accessible after installation.
- Water pressure on-site:  
Minimum: 14.5 psi  
Maximum: 145 psi, if higher, install a pressure reduction valve.
- Suitable 1/4" tubing or copper piping must be supplied for plumbing.
- To ensure the best ice cube quality, the maximum length of the tubing or copper pipe should not exceed 4 ft. 11" (1.5 m). If too much water remains in the tubing the quality could be affected.

### Connecting to the water supply

- Disconnect the machine from the electrical supply.

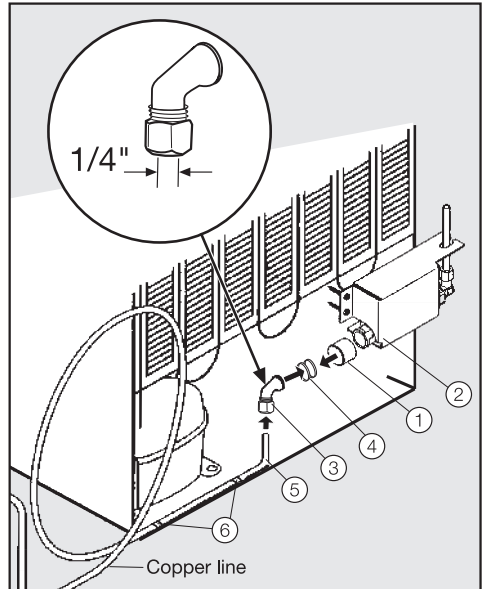

- Remove the cover cap ① from the solenoid valve ②.
- Install the compression fitting ③ with the sealing ring ④ on the solenoid valve ②.
- Attach the copper line ⑤ to the compression fitting ③.
- Secure the copper line to the appliance using cable clips ⑥.

## Plumbing (may vary by model)

---

- Open the valve for water supply and check entire water system for leaks.

Before using the appliance for the first time, a licensed plumber should bleed air from the system.

- Please use caution.
- Slide the appliance into the desired position.

After a maximum of 24 hours the first ice cubes will drop out of the ice cube maker and collect in the drawer.

## Electrical information

---

The appliance is delivered ready for connection to a 60 Hz 115 V power supply. It is only suitable for plugging into a properly grounded socket that complies with regulations. The appliance must only be plugged into a wiring system that complies with the local Electrical Code.

The fuse must be rated at least 10 A.

Ideally, the socket should be next to the appliance and easily accessible. Do not connect the appliance to the power supply by an extension cord. Extension cords do not guarantee the required safety of the appliance (danger of overheating, for example).

If any changes are needed to the household wiring or power supply, this must be performed by a qualified electrician only.



Do not place any items that produce heat on top of the appliance (such as a toaster or microwave). This will increase the amount of energy the appliance consumes.

This fridge/freezer should not be placed in a side-by-side formation with a second model. Because the appliance does not have heated side walls, a side-by-side arrangement can lead to the build-up of condensation water. Contact your dealer for advice.

## Location

The appliance should not be installed directly next to a heat source (such as a stove/oven or a radiator), or in direct sunlight. The higher the adjacent temperature, the more energy the appliance requires to keep cool. Choose a dry, well-ventilated room for installation.

## Climate range

The appliance is designed for use within a certain temperature range (room temperature), and should not be used outside this range. The climate range is stated on the model plate inside the appliance.

Climate range	Room temperature
SN	+10 °C to +32 °C (50 F to 90 F)
N	+16 °C to +32 °C (61 F to 90 F)
ST	+18 °C to +38 °C (64 F to 100 F)
T	+18 °C to +43 °C (64 F to 109)

If the room is too cold, it will cause the cooling system in the appliance to switch off for too long. This can cause the internal temperature to rise.

## Proper ventilation

The air behind the appliance gets warm. In order to ensure adequate ventilation, you must ensure that the vents are not covered or blocked in any way. Also, the vents must be dusted/cleaned on a regular basis.

## Installation

- First remove any cable clips from the rear of the appliance.
- Check that all parts on the rear the appliance are free to move. Remove any obstructions.
- Gently slide the appliance into the desired location. The rear of the appliance can be directly against the wall.

# Installation information

---

## Adjustments

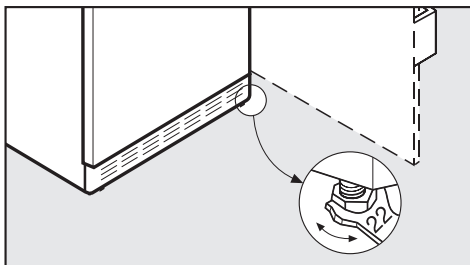

- Use the flat wrench provided to adjust the feet as needed, so that the appliance is even all around.

# Changing the door hinging

The appliance is delivered with right-hand hinging. If left-hand door hinging is preferred, then follow these instructions to change the door hinge.

## Remove the door handles

Begin by releasing the sidebars from the door handles, as follows:

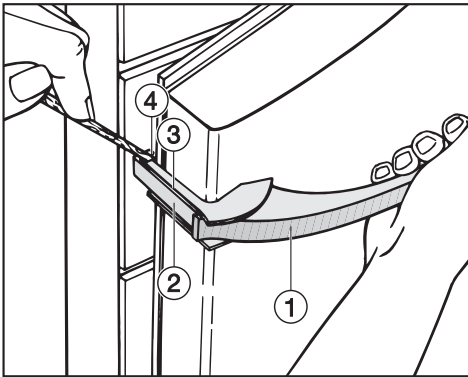

- When you pull on the door handle ①, the sidebar ② moves backward and creates a gap ④ between the handle sidebar ② and the mounting plate ③ for the handle.
- Use a blunt object (such as a wooden spoon handle) to keep the gap ④ open, and push the handle slowly back toward the door.

Make sure that the blunt object does not slip and damage the appliance.

The sidebar ② will now come loose.

- Pull it ② out of the track.
- Now loosen the 4 screws (Torx 15) in the mounting plate and remove the handle.

- Remove the covers from the opposite side and place them on the holes that are left.

## Switching the appliance doors

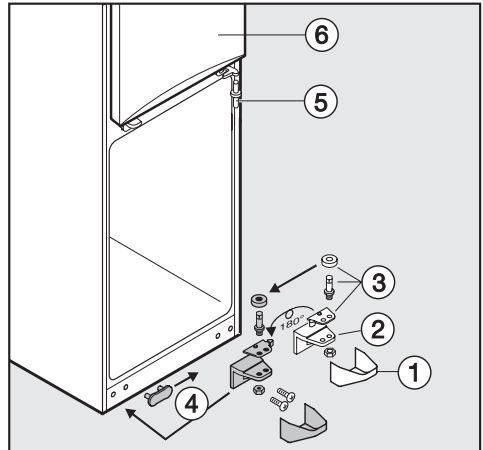

- Pull off the cover ①.
- With the door closed, unscrew the lower hinge bracket ②, then remove the door downward.
- Now place the panel ④ in position on the opposite side.
- Remove the hinge parts ③ from the hinge bracket ②, and re-insert them in the second hole on the hinge bracket.
- With the upper door of the appliance ⑥ closed, pull the bearing pin ⑤ downward to remove.
- Open the upper appliance door, then remove it by pulling it downward.

## Changing the door hinging

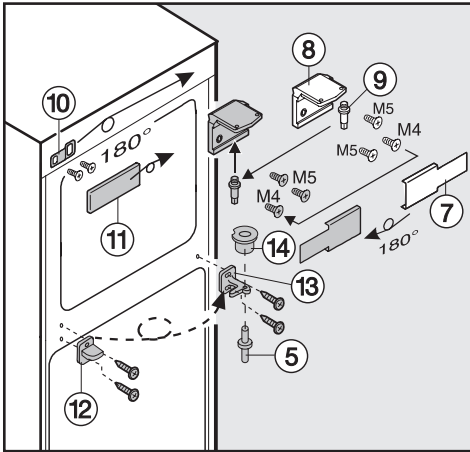

- Pull off the cover (7), and unscrew the hinge bracket (8).
- Insert the pin (9) into the second hole of the hinge bracket (8).
- Rotate the steel angle (10) and the cover (11) 180° each, then fit them on the opposite side.
- Screw the hinge bracket (8) on the opposite side. The **M4 screw** must be screwed into the left hole of the hinge bracket.
- Now rotate the cover (7) 180° and mount it on the opposite side.
- In the middle of the appliance, exchange the cover (12) and the bearing bracket (13), as follows: Unscrew the cover (12) and the bearing bracket (13), rotate them 180°, and screw them into place on the opposite side.
- Pull the bearing bushing (14) downward and out of the bearing bracket (13), then re-insert it into the bearing bracket from the top.

- Remove the plugs from the door bearing bushings at the top of the appliance doors, and fit them into place on the opposite side.
- Hang the upper appliance door on the pin (9), and close the appliance door.
- Insert the middle bearing pin (5) through the bottom of the bearing bracket (13) in the upper appliance door.
- Check to see that the upper appliance door is properly aligned. Make any needed adjustments by using the length holes in the bearing bracket (13).

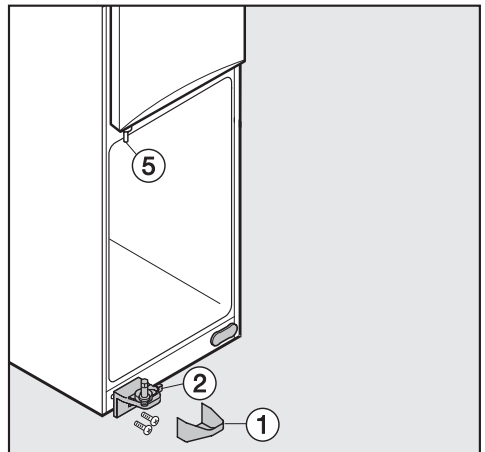

- Hang the lower appliance door on the pin (5), and close the appliance door.
- Insert the lower hinge bracket (2) in the door bearing bushing in the lower appliance door, and screw it completely onto the housing.
- Snap on the cover (1).

## Changing the door hinging

### Mount the door handles back into place.

The following instructions must be followed when attaching the door handle, because the door seal could be damaged otherwise.

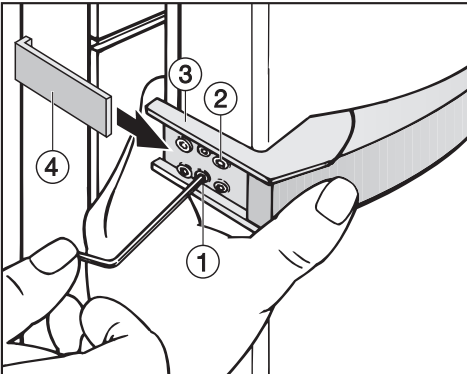

- First, loosely screw the door handle onto the opposite side, using the two forward screws ②.

The mounting plate ③ must be positioned on the door housing in such a way that when the door is **closed**, the mounting plate is aligned with the outside wall of the appliance. If this alignment is off, you can correct it by

- turning both of the pre-mounted set screws ① with a wrench until the mounting plate ③ reaches the correct angle.
- Tighten all 4 of the screws ②.

- Starting from the appliance side, slide the sidebar ④ onto the guide for the mounting plate, until it audibly clicks into place.

You must make sure that the sidebar ④ does not come in contact with the door seal when the door is opened. This will damage the door seal over time.

If you see that the sidebar is coming into contact with the door seal,

- you must adjust the mounting plate ③ again, using the set screws ①, until the mounting plate and the sidebar ④ are at the appropriate angle, and the seal is no longer touched when the door is opened.

# Installing the appliance

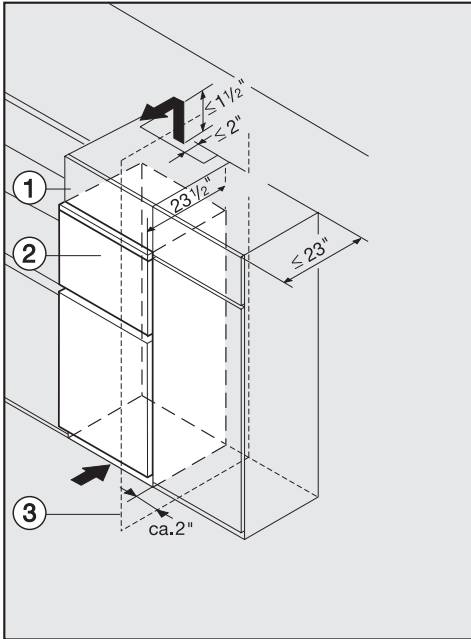

The air intake and outlet must not be blocked or covered in any way. They also need to be dusted/cleaned on a regular basis.

If the appliance is installed next to a wall ③, a gap of approx. 50 mm (2") is needed on the hinge side between the wall and the appliance ②, so that the appliance doors can be completely open, with space for the handle.

The appliance can be installed in any kitchenette. To match the appliance to the height of the kitchenette, a suitable adapter cabinet ① can be installed over the appliance.

A ventilation gap of at least 50 mm (2") depth must be left behind the appliance. The gap between the appliance/adapter cabinet and the room ceiling must be at least 40 mm (1 9/16"), so that warm air can escape without obstruction. Otherwise the appliance has to work harder, which results in increased energy consumption. The greater the ventilation cross-section, the more energy-efficient the appliance can be.





## **Miele Limited**

### **Headquarters and Showroom**

161 Four Valley Drive  
Vaughan, ON L4K 4V8

Phone: 800-643-5381  
905-660-9936

Fax: 905-532-2290

[www.miele.ca](http://www.miele.ca)

[info@miele.ca](mailto:info@miele.ca) (general enquiries)

[professional@miele.ca](mailto:professional@miele.ca) (commercial enquiries)

### **MieleCare National Service**

Phone: 800-565-6435  
905-532-2272

Fax: 905-532-2292

[service@miele.ca](mailto:service@miele.ca) (technical enquiries)

---

Subject to change without notice / 2307

M.-Nr. 06 926 030 / 00

KFN 8992 SD ed  
KFN 8993 SDE ed





## Free Manuals Download Website

<http://myh66.com>

<http://usermanuals.us>

<http://www.somanuals.com>

<http://www.4manuals.cc>

<http://www.manual-lib.com>

<http://www.404manual.com>

<http://www.luxmanual.com>

<http://aubethermostatmanual.com>

Golf course search by state

<http://golfingnear.com>

Email search by domain

<http://emailbydomain.com>

Auto manuals search

<http://auto.somanuals.com>

TV manuals search

<http://tv.somanuals.com>