

Big 40[®] Diesel

Issued October 2008 • Index No. ED/8.5

**Diesel Engine-Driven
Welder/Generator** 

Quick Specs



Heavy Industrial Applications

Petro Chemical Piping
Structural Steel Work
Maintenance and Repair

Processes

CC and CC/CV Models

Stick (SMAW)
TIG (GTAW)
Air Carbon Arc (CAC-A)
Cutting and Gouging
(Rated) 5/16 (7.9 mm) carbons
(Capable) 3/8 (9.5 mm) carbons
Stud Welding

CC/CV Model Only

MIG (GMAW)
Flux Cored (FCAW)
AC TIG (Deluxe Model)

Output Range

CC: DC Stick 55–500 A DC/TIG 55–500 A
CC/CV: DC Stick 40–550 A DC/TIG 20–350 A
AC TIG 15–375 A MIG/FCAW 14–40 V

Generator Output Rated at 104°F (40°C)

5500 Watts Peak—4000 Watts Continuous
15,000 Watts 3-Phase / 12,000 Watts 1-Phase
(Deluxe Model)

**Accu-Rated™—Not Inflated
Generator Power**

The Power of Blue.[®]

AC TIG weld aluminum with deluxe model. The most AC weld output on any engine drive. (High-frequency unit required.)

Silenced—only 65 dB (90 Lwa) at idle. 73.8 dB at 23 ft (98.7 Lwa) maximum output. Improves work site communications.

Automatic idle saves fuel and prolongs engine life along with reducing the sound level.

Quick and easy maintenance with single-side access to oil level check, oil fill, oil filter, fuel filter and air cleaner.

Enclosed base and case protects internal components from corrosive environments and reduces sound levels.

Remote toolless oil drain that allows oil to be drained without getting under the engine and reduces the chance of oil spillage.

Hot Start™ provides positive Stick electrode starts to make it easy to start all types of electrodes, and works great for bead tie-ins.



CC/CV Models: The Vault—ultimate control board reliability. See page 4.

BUILT TOUGH

Improved!
Maintenance Displays!



CATERPILLAR industrial engine designed to operate over 10,000 hours before the first basic overhaul. Backed by worldwide CAT support and service.

NEW! Meter maintenance displays.

- Hour meter function
- Oil change interval
- High coolant temperature and low oil pressure shutdowns
- Low fuel shutdown—engine shuts down before system runs out of fuel, making restarts easy.

Simplified control panel provides easy set-up with fewer controls—less training is required.

More welding amperage!

400 amps at 100% Duty Cycle
450 amps at 60% Duty Cycle
500 amps at 40% Duty Cycle

Engine gauges indicate engine oil pressure, and coolant temperature (standard on all models).

Arc-Drive makes welding easy. Automatically enhances Stick welding, especially on pipe, by focusing the arc and preventing the electrode from going out.

Standard GFCI receptacle required on most job sites to protect operators from electrical hazards.

CSA, IEC, and NEMA compliant for welders. Degree of protection provided by enclosure IP23.

TRUE BLUE[®]
3YR. WARRANTY

Welder/generator is warranted for 3 years, parts and labor.
The CATERPILLAR engine is warranted for 2 years by CATERPILLAR.

MADE IN USA
APPLETON, WI



Miller Electric Mfg. Co.
An Illinois Tool Works Company
1635 West Spencer Street
Appleton, WI 54914 USA

International Headquarters
Phone: 920-735-4505
USA FAX: 920-735-4134
Canadian FAX: 920-735-4169
International FAX: 920-735-4125

Web Site
www.MillerWelds.com



Big 40[®] Diesel CC Specifications (Subject to change without notice.)



Welding Mode	Weld Output Range	Weld Output Rated at 104°F (40°C)	Max. Open-Circuit Voltage	Generator Output Rated at 104°F (40°C)	Dimensions*	Net Weight (without fuel)**
CC/DC	55 – 500 A	400 A at 36 VDC (14.4 kW), 100% Duty Cycle 450 A at 38 VDC (17.1 kW), 60% Duty Cycle 500 A at 30 VDC (15 kW), 40% Duty Cycle	95	Peak: 5500 watts Continuous: 4000 watts, 34/17 A, 120/ 240 VAC, 60 Hz while welding	H: 43 in (1092 mm) W: 28-1/2 in (724 mm) D: 64-7/16 in (1637 mm)	1540 lb (697 kg)

NEMA EW1 (ANSI C87.1) Class (1) output ratings. *Additional 7 in (178 mm) to top of exhaust. **Additional 190 lb (86 kg) when fuel tank is full.

Engine Specifications (Subject to change without notice.)

Engine Brand	Features	HP	Type	Engine Speeds	Fuel Capacity	Oil Capacity	Coolant Capacity	Automatic Engine Shutdown
CATERPILLAR Tier IVi, C2.2 Diesel	Tier IVi, EPA-certified, indirect-injected, liquid-cooled diesel engine. Right-side service access with service intervals of 500 hours for oil and filters .	32.6	Four-cylinder, industrial, liquid-cooled diesel	Run: 1850 RPM Idle: 1250 RPM	25 gal (95 L)	9 qt (8.5 L)	9 qt (8.5 L)	Oil Pressure Coolant Temperature

Big 40[®] Diesel CC Control Panel

Additional Features

Proven, rugged rheostat control technology that has been in Miller engine drives for over 60 years. Contains no printed control boards.

Provisions are provided to plug a **RHC3GD34A remote control** that will allow precise adjustment of amperage without walking back to the machine.

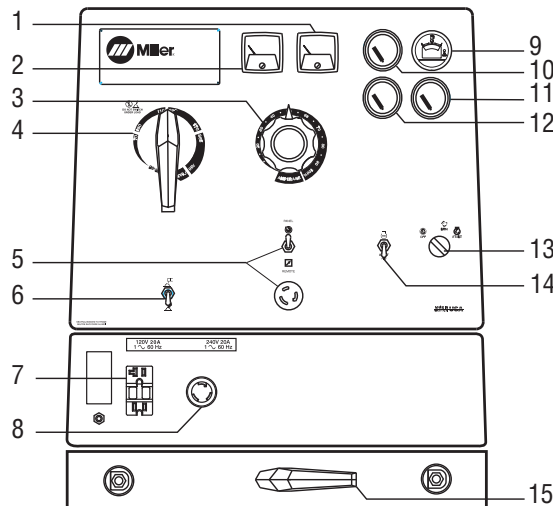

1. DC Ammeter*
2. DC Voltmeter*
3. Amperage Adjust Control
4. Amperage Range Switch
5. Amperage Adjust Switch and Remote Amperage Adjust Receptacle
6. Stick/TIG Selector Switch
7. 120 VAC, 20 A GFCI Duplex Receptacle
8. 240 VAC, 30 A TwistLock Receptacle (NEMA L6-30)
9. Fuel Gauge/Hour Meter/Oil Change Interval/Engine Shutdown Indicator
10. Engine Oil Pressure Gauge
11. Battery Voltmeter*
12. Engine Coolant Temperature Gauge
13. Engine Control Switch
14. Starting Aid Switch
15. Polarity Switch*

*Optional on select models.

Big 40[®] Diesel CC Performance Data

CC/DC VOLT/AMP CURVES

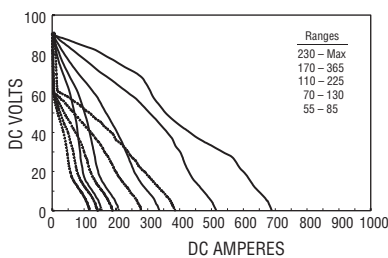

GENERATOR POWER CURVE

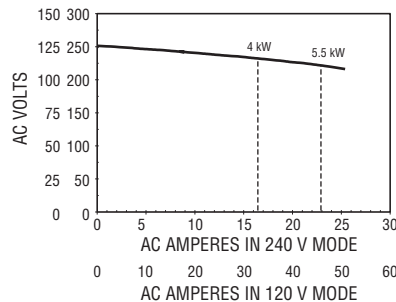

FUEL CONSUMPTION CURVE

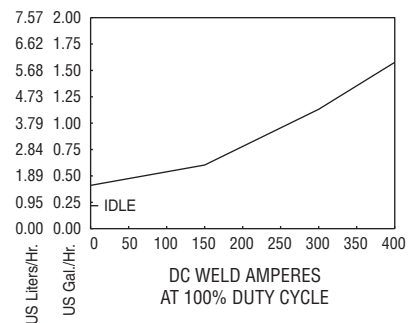

Big 40[®] Diesel CC/CV Specifications (Subject to change without notice.)



Welding Mode	Weld Output Range	Weld Output Rated at 104°F (40°C)	Max. Open-Circuit Voltage	Generator Power Output Rated	Dimensions*	Net Weight (without fuel)**
CC/DC	20–550 A	400 A at 36 VDC (14.4 kW), 100% Duty Cycle	95	Peak: 5000 watts Continuous: 4000 watts, 34/17 A, 120/240 VAC, 60 Hz while welding Deluxe Model Additional Power Plant: 1-phase, 12 kW, 50 A, 120/240 VAC, 60 Hz; or 3-phase, 15 kW, 36 A, 240 VAC, 60 Hz while not welding	H: 43 in (1092 mm) W: 28-1/2 in (724 mm) D: 64-7/16 in (1637 mm)	1545 lb (701 kg)
CV/DC	14–40 V	450 A at 38 VDC (17.1 kW), 60% Duty Cycle 500 A at 34 VDC (17 kW), 40% Duty Cycle	56			
CC/AC (Deluxe Model)	15–375 A	300 A at 32 VAC (9.6 kW), 100% Duty Cycle 335 A at 33 V (11.1 kW), 60% Duty Cycle 375 A at 35 V (13.1 kW), 40% Duty Cycle	65			

NEMA EWI (ANSI C87.1) Class (1) output ratings. *Additional 7 in (178 mm) to top of exhaust. **Additional 190 lb (86 kg) when fuel tank is full.

Big 40[®] Diesel CC/CV Control Panel

Additional Features

A multi-colored **process selector control** allows quick and easy process changes without having to use multiple switches.

Heavy-Duty Design — The **Vault** design provides enhanced arc characteristics that include more dig in the Stick mode with smoother and lower amperage in the TIG mode. Along with the superior welding performance, the **Vault** provides the ultimate reliability in the harshest of environments.

A hermetically-sealed vault protects Miller control boards from dust, moisture, and tough environmental elements. Extreme conditions will not cause the output to change, eliminating the need to periodically turn up the heat.

15,000 watt generator option for stand-by power generation adds 15 kW, three-phase, 240 volt power to CC/CV units. 12 kW, 120/240 volt, single-phase power from a 50 amp receptacle while not welding.

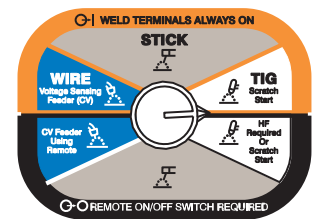
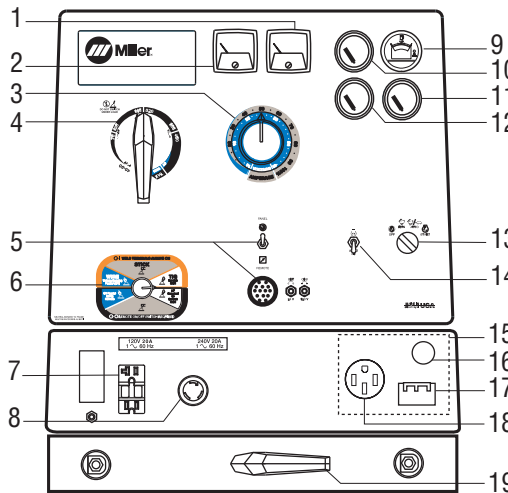

Process/Contactor Selector Switch

1. DC Ammeter*
 2. DC Voltmeter*
 3. Amperage/Voltage Adjust Control
 4. Ampere Range Switch
 5. Amperage/Voltage Adjust Switch and Remote Amperage/Voltage Adjust Receptacle
 6. Process/Contactor Selector Switch
 7. 120 VAC, 20 A GFCI Duplex Receptacle
 8. 240 VAC, 30A TwistLock Receptacle (NEMA L6-30)
 9. Fuel Gauge/Hour Meter/Oil Change Interval/Engine Shutdown Indicator
 10. Engine Oil Pressure Gauge
 11. Battery Voltmeter*
 12. Engine Coolant Temperature Gauge
 13. Engine Control Switch
 14. Starting Aid Switch
 15. 3-Phase Power Generator Option*
 16. Strain Relief*
 17. 50 A, 3-Phase Circuit Breaker
 18. 50 A, 120/240 V Receptacle (NEMA 14-50)*
 19. AC/DC Polarity Switch*
- *Optional on select models.

Big 40[®] Diesel CC/CV Performance Data

CC/CV VOLT/AMP CURVES
STICK MODE

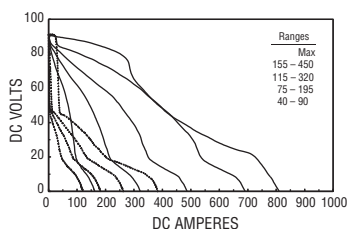

CC/CV VOLT/AMP CURVES
MIG MODE

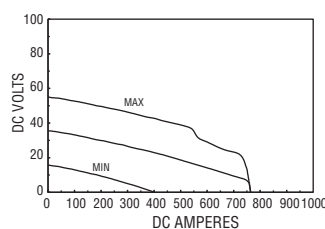

CC/CV VOLT/AMP CURVES
TIG MODE

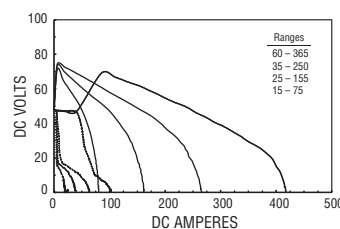

CC/CV VOLT/AMP CURVES
AC TIG MODE

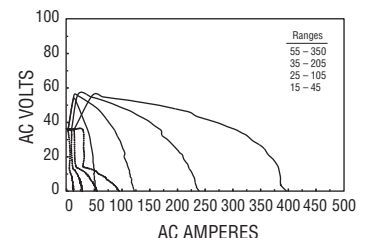

Big 40® Diesel CC Options

Weld Ammeter and Voltmeter Kit

#195 131 Field

Panel-mounted analog meters monitor welding output.

Installation time: 35 minutes

Cold Weather Starting Aid Kit

#195 056 Field

Includes 120 V block heater.

Note: All models come standard with glow plugs.

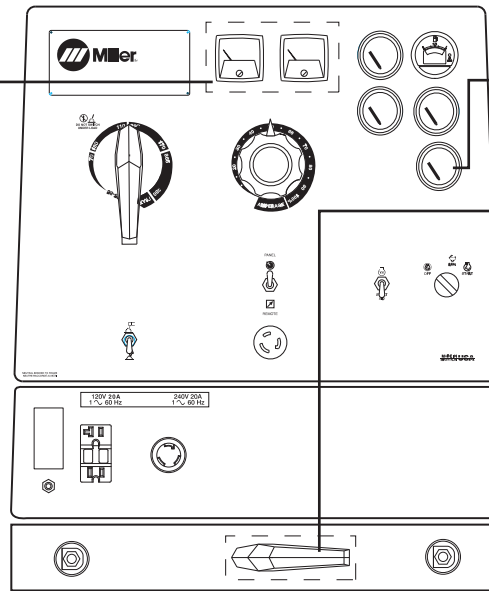

Battery Voltage Gauge

#195 454 Field

Monitors battery charging circuit.

DC Polarity Reversing Switch Kit

#043 942 Field

Changes DC polarity without the use of tools.

Installation time: 35 minutes

Big 40® Diesel CC/CV Options

Weld Ammeter and Voltmeter Kit

#195 131 Field

Panel-mounted analog meters monitor welding output. *Deluxe model comes standard with weld meters.*

Installation time: 35 minutes

AC/DC Polarity Reversing Switch Kit

#195 095 Field

Changes DC+/AC/DC- without the use of tools. *Deluxe model comes standard with AC/DC polarity switch.*

Installation time: 35 minutes

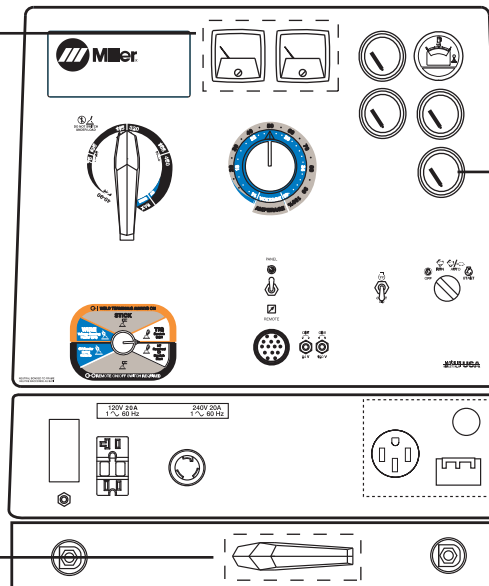

Battery Voltmeter

#195 454 Field

Monitors battery charging circuit.

Cold Weather Starting Aid Kit

#195 056 Field

Includes 120 V block heater.

Note: All models come standard with glow plugs.

15,000 Watt Generator Plant

12,000 Watts, 1-phase, 120/240 V

15,000 Watts, 3-phase, 240 V

The panel is protected by a 50 amp on/off circuit breaker. It includes a 50 A, 1-phase receptacle and strain relief for direct hard-wiring. This power is only available while **NOT** welding. *Comes standard with deluxe model.*

Note: Available as factory option.
See Ordering Information on back page.

The Vault

Superior Circuit Board Design

Miller's critical circuit boards are engineered to carry *low power* and *low heat* to reduce thermal stress and minimize expansion and contraction. In contrast, our competitor's boards carry *high power* and *high heat*, making them more vulnerable to failure.

"The Vault" Makes Upgrading to Miller CC/CV Units Worry-Free

Concerns with circuit board reliability have resulted in some operators steering clear of CC/CV welder/generators — even though they

offer a superior arc and multiple welding processes. Miller's circuit board reliability isn't a concern since all PRO 300 and Big Blue multiprocess industrial engine drives feature the Vault.

Created out of two aluminum halves sealed with silicone, as well as watertight harness connections, the Vault provides a clean circuit board environment, protecting the electronics — and controlling output — in heavy industrial applications. No other competitor protects their electronics with a sealed vault, leaving critical



circuit boards exposed to harsh elements that can disrupt the machine's electronics, and therefore, its operation.

Genuine Miller Accessories (Continued)



FA-1D Lockable Flame Arrestor Fuel Cap #043 947 Field
Fuel cap can be padlocked to prevent vandalism. A built-in flame arrestor prevents flames or sparks from entering the fuel tank.

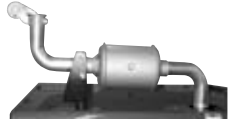

Spark Arrestor Muffler Kit #195 012 Field
Prevents particles from leaving the muffler that could potentially start a fire. Mandatory when operating on California grasslands, brush, or forest-covered land, and in all National Forests. For other areas, check your state and local laws. Meets US Forest Service standard 5100-1B.



Vandalism Lockout Kit #195 118 Field
Lockable hinged steel panels cover and protect name plate gauges and ignition switch (padlock included). Also includes engine compartment door lock and key.



Cable Holder #043 946
Saddle-bag-style cable holder. Convenient wrap-around storage of coiled cable for transportation. Stores 100 ft of 2/0 cable on each side.

Note: For best results do not weld when cable is coiled! Canvas cover cannot be used with cable holder.



Roll Cage/Drip Pan #194 918 Field
Heavy-duty galvanized steel structure designed to protect the machine. The roll cage meets offshore oil platform requirements with a drip pan and drain plug along with a heavy-duty lift eye.



Canvas Cover (Blue) #194 683 Field
Attractive, waterproof canvas cover resists stains and mildew, and protects the finish of your welder.

Note: Canvas cover cannot be used with cable holder.

Stick (SMAW) Welding

Weld Leads

#173 851 2/0, 350 A, 100% duty cycle, 50 ft stinger, 50 ft work cable
#043 952 2/0, 300 A, 100% duty cycle, 100 ft stinger, 50 ft work cable

Plasma Cutting



Spectrum® 375 X-TREME™ #907 303
Spectrum® 375 X-TREME™ with X-CASE™ #907 339 (not shown)
See Lit. Index No. PC/9.2.
Spectrum® 625 #907 058
See Lit. Index No. PC/9.5.
Spectrum 2050 #903 777-01-2
See Lit. Index No. PC/7.0.

MIG (GMAW) or Flux Cored (FCAW)



Millermatic® Passport® Plus #907 401
Portable, all-in-one MIG package features ultimate arc performance, self-contained gas

bottle, and flexibility to plug into 115 or 230 V power with Miller exclusive Multi-Voltage Plug. See Lit. Index No. DC/12.53.



SuitCase™ X-TREME™ 8VS Wire Feeder #300 093
SuitCase™ X-TREME™ 12VS Wire Feeder #195 500
Lightweight, voltage-sensing wire feeders include secondary contactor and gas valve. Require drive roll kit. See Lit. Index No. M/6.41.



SuitCase™ 8RC Wire Feeder #194 938
SuitCase™ 12RC Wire Feeder #194 940
Lightweight and flexible enough to run a variety of wires up to .062 in diameter. Comes standard with remote voltage control. See Lit. Index No. M/6.5.

MIG (GMAW)/Flux Cored (FCAW) Guns
Miller produces a complete line of dependable MIG guns. See Lit. Index Nos. AY/15.0, AY/16.0 and AY/17.0.



Spoolmatic® 30A Spool Gun #130 831
Air-cooled, 200-amp, 1-lb spool gun for aluminum MIG. See Lit. Index No. M/1.73.

WC-24 Control #137 549
Use with Spoolmatic 30A.

XR™ Wire Feeders and Guns
Push-pull system designed to handle difficult-to-feed soft alloy wires such as aluminum. See Lit. Index No. M/1.7, M/1.71, and M/1.73.

TIG (GTAW) Welding



Dynasty® 200 Series
For premium portable AC/DC TIG arc quality. See Lit. Index No. AD/4.8.



HF-251 Series #042 388
HF-251D-1, 115 VAC
#042 387
HF-251D-2, 230 VAC
High-frequency arc starter and stabilizer. See Accessory Lit. Index No. AY/5.0.

Genuine Miller Accessories (Continued)

Remote Controls (CC models only)



RHC-3GD34A Remote Hand Control #041 122
Allows for precise adjustment of amperage. Includes 20 ft (6 m) cord.



RFCS-14 HD Foot Control #194 744
Foot current and contactor control. 20 ft (6 m) cord and 14-pin plug.



RCC-14 Remote Contactor and Current Control #151 086
14-pin plug. Rotary-motion fingertip control fastens to TIG torch using two Velcro® straps. Includes 28 ft (8.5 m) control cord.

Remote Controls (CC/CV models)



RHC-14 Hand Control #129 340
Miniature hand control for remote current and contactor control. Dimensions: 4 x 4 x 3-1/4 in (102 x 102 x 82 mm). Includes 20 ft (6 m) cord and 14-pin plug.



RMLS-14 #129 337
Fingertip momentary- and maintained-contact rocker switch for contactor control. Push forward for maintained contact and back for momentary contact. Includes 20 ft (6 m) cord and 14-pin plug.



RCCS-14 Remote Contactor and Current Control #043 688
Up-and-down rotary-motion fingertip control fastens to TIG torch using two Velcro® straps. Includes 28 ft (8.5 m) control cord.

Extension Cords for 14-Pin Remote Controls
#122 973 25 ft (7.6 m)
#122 974 50 ft (15.2 m)
#122 975 75 ft (22.9 m)

Trailers and Hitches (For both models.)



4 West Four-Wheel Steerable Off-Road Trailer #042 801
A heavy-duty 2570 lb (1166 kg) capacity trailer designed for use in mines, quarries, and other rough terrain. Has narrow 22 ft (6.7 m) turning radius. Includes 3 in lunette eye, universal hitch and safety chains.

Note: Trailer is shipped unassembled.



HWY-224 Trailer #043 805 For highway use.
OFR-224 Trailer #043 802 For off-road use.
A 2650 lb (1202 kg) capacity trailer. Welded steel tubing frame, heavy-duty axle with roller bearing hubs and leaf-spring suspension. Includes jack stand, 2 in (50 mm) ball hitch. *HWY-224 also includes fenders and lights.*

Note: Trailer is shipped unassembled.

Cable Tree #043 826
Provides an area to conveniently wrap weld cables and extension cords.

Lunette Eye 2-1/2 in (64 mm) #043 824



HWY-430 Tandem Axle Trailer #043 806
Smooth riding with 3750 lb (1701 kg) capacity. Includes hand-operated parking brake, hydraulic brake system, and a break-away device to lock brakes if the trailer comes loose. Includes jack stand, fenders and lights. (Hitch must be ordered separately.)

Note: Some assembly required.

Cable Tree #043 826
Provides an area to conveniently wrap weld cables and extension cords.

Ball Hitch 2 in (50 mm) #043 864

Lunette Eye 3 in (76 mm) #043 863

Trailer Specifications (Subject to change without notice.)

Model	Gross Axle Weight Rating	Gross Vehicle Weight Rating	Net Payload	Height of Bed	Road Clearance	Track (Center to center of tires)	Standard Tires (Standard rating or P-size rating)	Dimensions	Net Weight
4 West	2000 lb/axle (907 kg/axle)	3000 lb (1361 kg)	2570 lb (1166 kg)	21-1/4 in (540 mm)	8 in (203 mm)	55-1/4 in (1403 mm)	B78-13	Length: 91 in (2311 mm)** Width: 61-1/4 in (1556 mm)	430 lb (195 kg)
HWY-224 OFR-224	3500 lb (1588 kg)	2960 lb (1343 kg)	2650 lb (1202 kg)	18-1/2 in (470 mm)	7-1/2 in (191 mm)	52 in (1321 mm)	B78-13B	Length: 122-1/2 in (3112 mm) Width: HWY- 61 in (1549 mm)* OFR-58-1/2 in (1486 mm)	355 lb (161 kg)
HWY-430	2200 lb/axle (998 kg/axle)	4280 lb (1941 kg)	3750 lb (1701 kg)	19-1/4 in (489 mm)	8-1/2 in (216 mm)	52 in (1321 mm)	B78-13B	Length: 156-1/2 in (3975 mm) Width: 61 in (1549 mm)*	530 lb (240 kg)

* Width at outside of fenders. ** Does not include tongue.

Typical Installations



Stick (SMAW) Basic Equipment

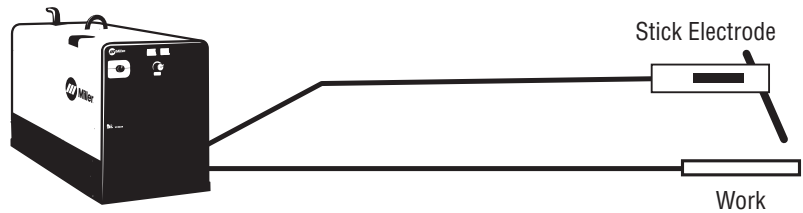

Flux-Cored (FCAW) Basic Equipment

SuitCase™ X-TREME™ 8VS #300 093
 SuitCase™ X-TREME™ 12VS #195 500

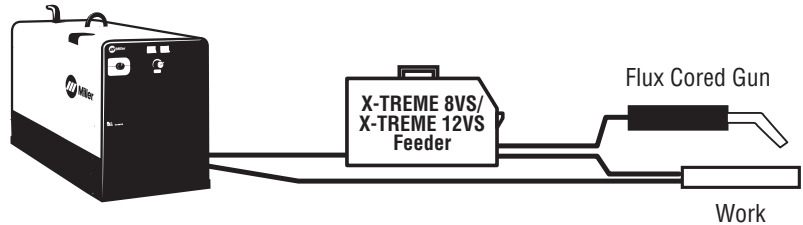

MIG (GMAW) Basic Equipment

SuitCase™ 8RC #194 938
 SuitCase™ 12RC #194 940

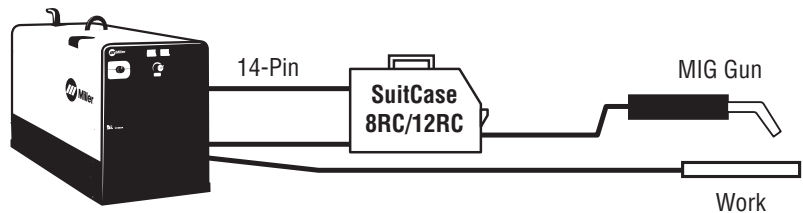

Aluminum MIG (GMAW) Basic Equipment

Spoolmatic® 30A #130 831
 WC-24 #137 549

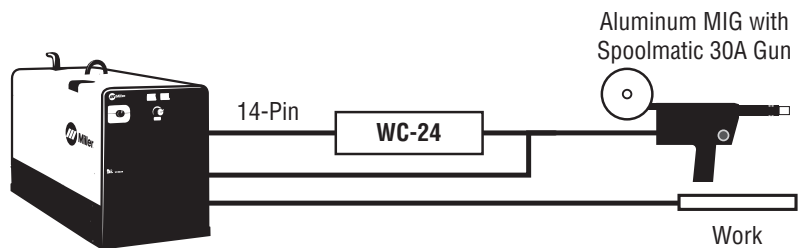

TIG (GTAW) Basic Equipment

Dynasty® 200 Series
 HF-251D-1 #042 388*
 *TIG power cable adapter required

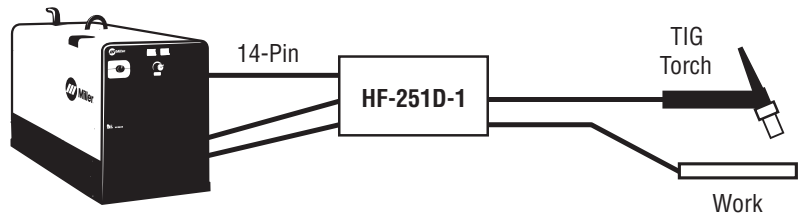

Plasma Basic Equipment

Spectrum® 375 X-TREME™ #907 303
 Spectrum® 375 X-TREME™ with X-CASE™ #907 339
 Spectrum® 625 #907 058
 Spectrum® 2050 #903 777-01-2

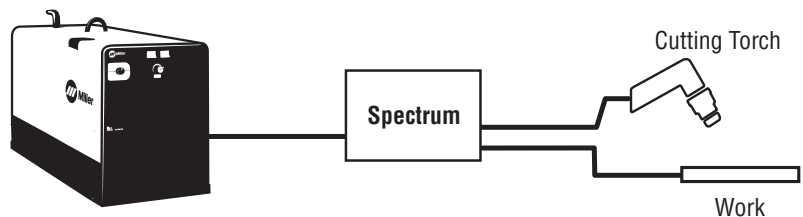

Ordering Information

Power Source and Factory Options	Stock No.	Description	Qty.	Price
Big 40® Diesel CC	#907 171	CSA model with engine gauges and automatic idle		
Big 40® Diesel CC/CV	#907 170 #907 170-03-1	CSA model with engine gauges and automatic idle CSA Deluxe model w/ automatic idle, engine gauges, welding meters, AC/DC polarity switch and high kW option		
Field Kit Accessories				
Weld Ammeter and Voltmeter Kit	#195 131	Standard on deluxe model		
Battery Voltmeter	#195 454			
DC Polarity Switch Kit	#043 942	Changes DC polarity positive to negative		
AC/DC Polarity Switch Kit	#195 095	For CC/CV models. Standard on deluxe model		
Cold Weather Starting Aid Kit	#195 056	120 V block heater		
Lockable Fuel Cap Flame Arrestor Kit	#043 947	Padlock not included		
Spark Arrestor Muffler Kit	#195 012	Horizontal externally mounted		
Vandalism Lockout Kit	#195 118	Lockable front control panel and engine compartment		
Cable Holder	#043 946	Saddle-bag-style. Fastens to machine		
Roll Cage/Drip Pan	#194 918			
Canvas Cover	#194 683	Field. Cannot be used with cable holder		
Stick Accessories				
Accessory Kits	#173 851 #043 952	2/0, 350 A, 100% duty cycle, 50 ft (15 m) stinger, 50 ft (15 m) work clamp 2/0, 300 A, 100% duty cycle, 100 ft (30.5 m) stinger, 50 ft (15 m) work clamp		
MIG/Flux Cored Accessories				
Millermatic® Passport® Plus	#907 401	Includes gas bottle and MVP. See Lit. Index No. DC/12.53		
SuitCase™ X-TREME™ 8VS	#300 093	See Lit Index No. M/6.41		
SuitCase™ X-TREME™ 12VS	#195 500	See Lit Index No. M/6.41		
SuitCase™ 8RC	#194 938	See Lit Index No. M/6.5		
SuitCase™ 12RC	#194 940	See Lit Index No. M/6.5		
MIG (GMAW)/Flux Cored (FCAW) Guns		See Lit Index Nos. AY/15.0, AY/16.0 and AY/17.0		
Spoolmatic® 30A Spool Gun	#130 831	Requires WC-24 Control. See Lit. Index No. M/1.73		
WC-24 Control	#137 549	See Lit. Index No. M/1.5		
XR™ Wire Feeder Control and Guns		See Lit. Index No. M/1.7, M/1.71, and M/1.73		
TIG Accessories				
Dynasty® 200 Series		See Lit Index No. AY/4.8		
High Frequency Arc Starters		See Lit. Index No. AY/5.0		
Remote Controls				
RHC-3GD34A	#041 122	CC models only, hand control		
RHC-14	#129 340	CC/CV models only, amperage or voltage control		
RFCS-14 HD	#194 744	CC/CV models only, foot control		
RMLS-14	#129 337	CC/CV models only, momentary and maintained contact switch		
RCC-14	#151 086	CC/CV models only, fingertip control		
RCCS-14	#043 688	CC/CV models only, fingertip control		
Remote Control Extension Cords		See page 6		
Trailers and Hitches				
4-West Trailer	#042 801	4-wheel steerable implement trailer		
HWY-224 Trailer	#043 805	Trailer with lights, fenders and 2 in ball hitch		
OFR-224 Trailer	#043 802	Trailer with 2 in ball hitch		
Lunette Eye, 2-1/2 in	#043 824	Replaces the 2 in ball hitch on the HWY-224 or OFR-224		
Cable Tree	#043 826	Trailer mounted cable holder for HWY-224, OFR-224 or HWY-430		
HWY-430 Trailer	#043 806	Hitch required		
Ball Hitch, 2 in	#043 864	For HWY-430 only		
Lunette Eye, 3 in	#043 863	For HWY-430 only		

Date:

Total Quoted Price:

Distributed by:



Free Manuals Download Website

<http://myh66.com>

<http://usermanuals.us>

<http://www.somanuals.com>

<http://www.4manuals.cc>

<http://www.manual-lib.com>

<http://www.404manual.com>

<http://www.luxmanual.com>

<http://aubethermostatmanual.com>

Golf course search by state

<http://golfingnear.com>

Email search by domain

<http://emailbydomain.com>

Auto manuals search

<http://auto.somanuals.com>

TV manuals search

<http://tv.somanuals.com>