

OM-533A

April 1993

Eff. w/Serial Number JJ487350

Processes



Multiprocess Welding

Description



Remote Pendant Control

RPC-IP

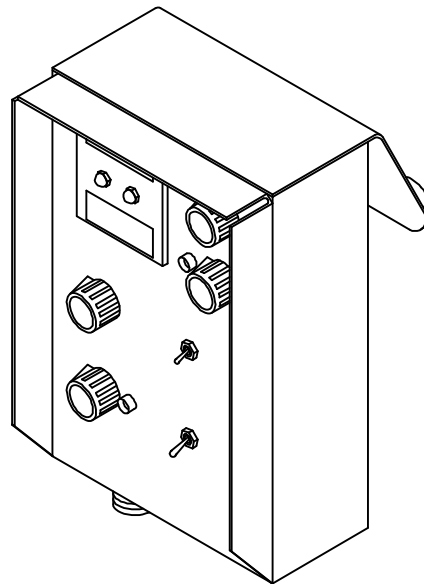

Visit our website at
www.MillerWelds.com

SECTION 1 – INTRODUCTION

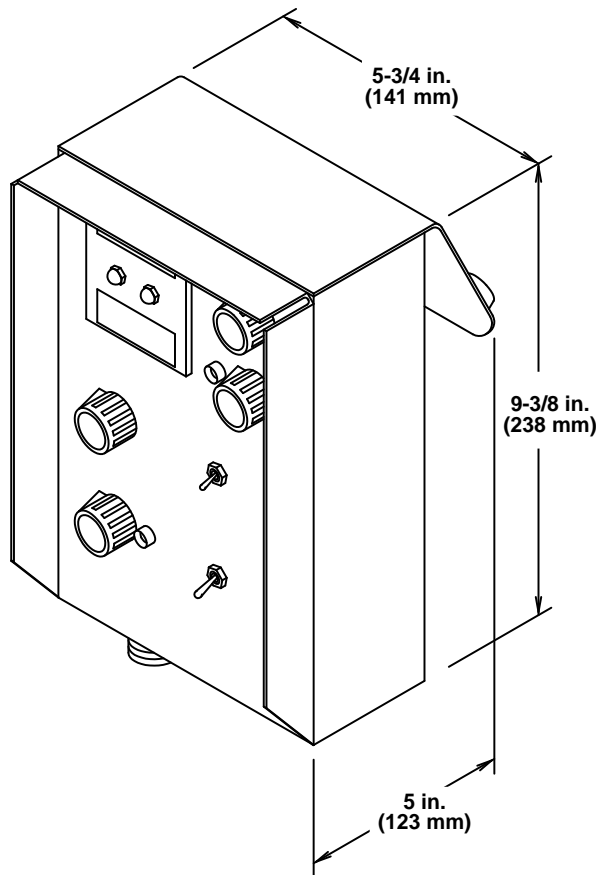

ST-109 521-A

Figure 1-1. Dimensions

1-1. GENERAL INFORMATION AND SAFETY

A. General

Information presented in this manual and on various labels, tags, and plates provided on this unit pertains to equipment design, installation, operation, maintenance, and troubleshooting which should be read, understood,

and followed for the safe and effective use of this equipment.

B. Safety

The installation, operation, maintenance, and troubleshooting of arc welding equipment requires practices and procedures which ensure personal safety and the safety of others. Therefore, this equipment is to be installed, operated, and maintained only by qualified persons in accordance with this manual and all applicable codes such as, but not limited to, those listed in Arc Welding Safety Precautions Section in the welding power source Owner's Manual.

Safety instructions specifically pertaining to this unit appear throughout this manual highlighted by the signal words **WARNING** and **CAUTION** which identify different levels of hazard.

WARNING statements include installation, operation, and maintenance procedures or practices which if not carefully followed could result in serious personal injury or loss of life.

CAUTION statements include installation, operation, and maintenance procedures or practices which if not carefully followed could result in minor personal injury or damage to this equipment.

A third signal word, **IMPORTANT**, highlights instructions which need special emphasis to obtain the most efficient operation of this equipment.

1-2. RECEIVING-HANDLING

Before unpacking equipment, check carton for any damage that may have occurred during shipment. File any claims for loss or damage **with the delivering carrier**. Assistance for filing or settling claims may be obtained from the distributor and/or the equipment manufacturer's Transportation Department.

When requesting information about this equipment, always provide the Model Description and Serial Number.

1-3. DESCRIPTION

This unit is a Remote Pendant Control for the Intellipulse welding power source. When properly connected to the welding power source this unit provides arc control, contactor control, voltage/ampere control, CV/CC selection, and pulse frequency selection.

SECTION 2 – INSTALLATION

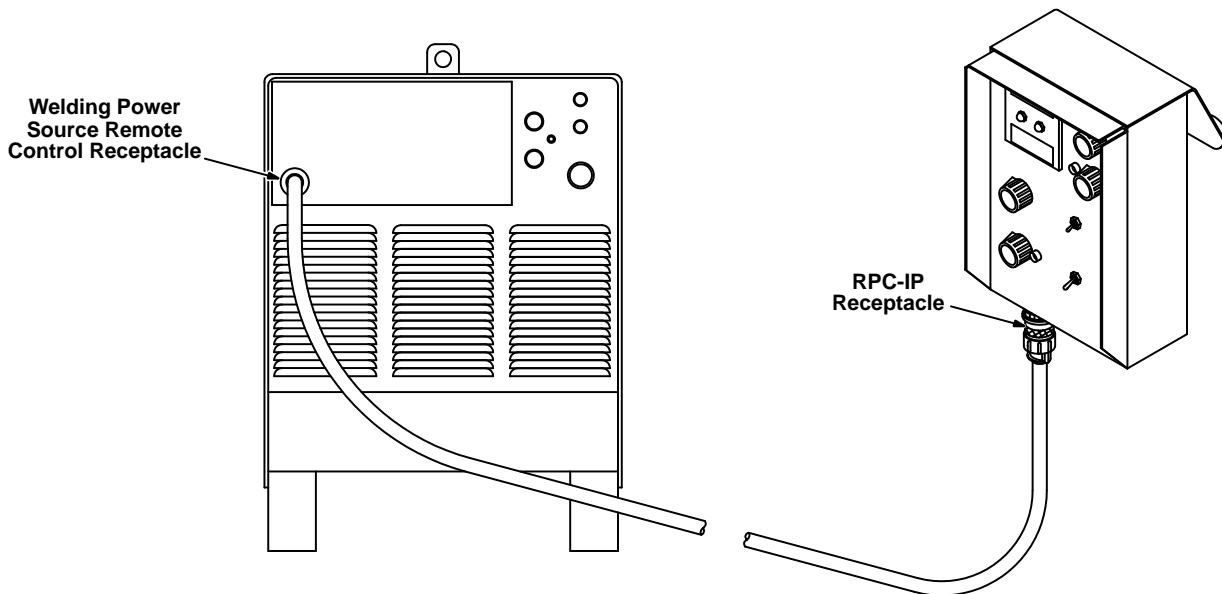

ST-109 782-B

Figure 2-1. Power Source/Remote Control Connections



WARNING: ELECTRIC SHOCK can kill.

- Do not touch live electrical parts.
- Shut down welding power source, and be sure it cannot be accidentally energized before making remote Pendant Control connections.
- Place CONTACTOR switch in OFF position.

2-1. WELDING POWER SOURCE REMOTE CONTROL RECEPTACLE CONNECTIONS (Figure 2-1)

The Remote Pendant Control connects to a 17-socket Amphenol receptacle on the welding power source front panel (see OM-286). Insert 17-pin Amphenol plug from the interconnecting cable fully into the receptacle and rotate collar clockwise.

2-2. RPC-IP RECEPTACLE CONNECTIONS (Figure 2-1)

The interconnecting cable from the welding power source connects to a 17-pin Amphenol receptacle on the remote control. Insert the 17-socket plug from the interconnecting cable fully into the receptacle, and rotate collar clockwise.

2-3. 650/1000 AMPERE MODEL SELECTOR SWITCH



WARNING: ELECTRIC SHOCK can kill.

- Do not touch live electrical parts.
- Shut down welding power source, and disconnect the Remote Pendant Control before changing position of dip switches.

ELECTROSTATIC DISCHARGE (ESD) can damage circuit boards.

- Put on properly grounded wrist strap BEFORE handling circuit boards.
- Perform work only at a static-safe work area.

This Remote Pendant Control is designed to be used with either a 650 or 1000 ampere intellipulse welding power source. A dip switch is located on circuit board PC5 to set up the Remote Pendant Control for operation with 650 or 1000 ampere models. The unit is shipped from the factory set up for operation with the 650 ampere models. Proceed as follows to set up the Remote Pendant Control for operation with 1000 ampere models:

1. Remove cover.
2. Place both dip switches in the down position for operation with 1000 ampere models. Place both dip switches in up position for operation with 650 ampere models (see Figure 2-2).
3. Reinstall cover.

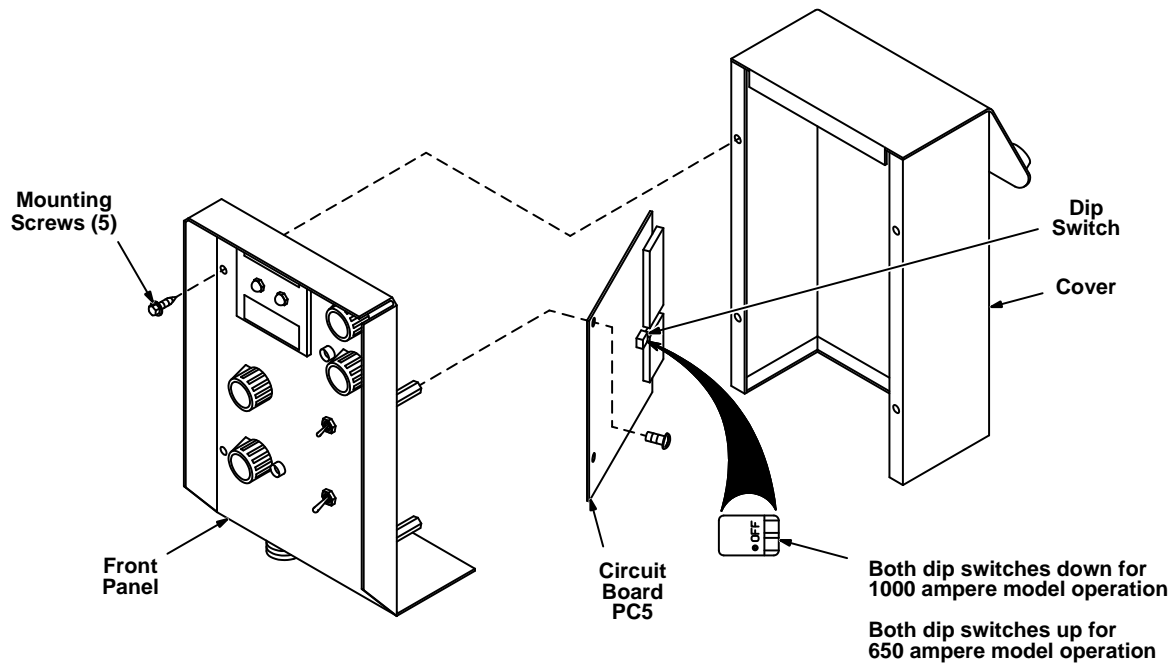

ST-113 509-A

Figure 2-2. Dip Switch Positions And Locations

SECTION 3 – OPERATOR CONTROLS

3-1. MODE SELECTOR SWITCH (Figure 3-1)

The Mode Selector switch allows selection of CC (constant current), CV (constant voltage), or pulsed output from the welding power source.

The CC position provides a constant current output specifically designed for Shielded Metal Arc (SMAW) and Gas Tungsten Arc (GTAW) Welding processes. The CC position is also normally used for Air Carbon Arc Cutting (CAC-A) and gouging processes.

The CV position provides a constant voltage output designed for wire feeding applications such as Gas Metal Arc (GMAW), Flux Cored Arc (FCAW), or Submerged Arc (SAW) Welding.

When pulsed output is desired for Gas Metal Arc Welding - Pulsed Arc (GMAW-P), place switch at the desired number of pulses per second: 60, 90, 120 or 180.

3-2. ARC CONTROL AND PILOT LIGHT (Figure 3-1)

IMPORTANT: *The ARC CONTROL potentiometer and pilot light are disabled in the CV (Constant Voltage) and pulsed modes.*

The ARC CONTROL potentiometer provides variable selection of short-circuit current to suit individual welding conditions. Rotating this control clockwise causes the current to increase as the short-circuit condition is

approached. When this control is set at some value above 0, the current begins to increase when arc voltage drops below 20 volts.

When the control is set at 10 (MAX.), the short-circuit current is considerably higher than normal welding current (see welding power source volt-ampere curve for CC mode). This provides extra current for arc starting in out-of-position welds as well as for certain types of electrodes.

When the control is set at 0 (SOFT), short-circuit current is the same as normal welding current. The 0 position provides current characteristics associated with the Gas Tungsten Arc Welding (GTAW) process.

When the control is set at 5, short-circuit current is approximately half that of the 10 (MAX.) position but still higher than normal welding current. The 5 position provides a moderate current increase for arc starting necessary for certain types of electrodes and applications.

Select a setting best suited for the application.

The Arc Control pilot light turns on when the Mode Selector switch is in the CC position indicating that the ARC CONTROL is active.

IMPORTANT: *The ARC CONTROL can be adjusted while welding.*

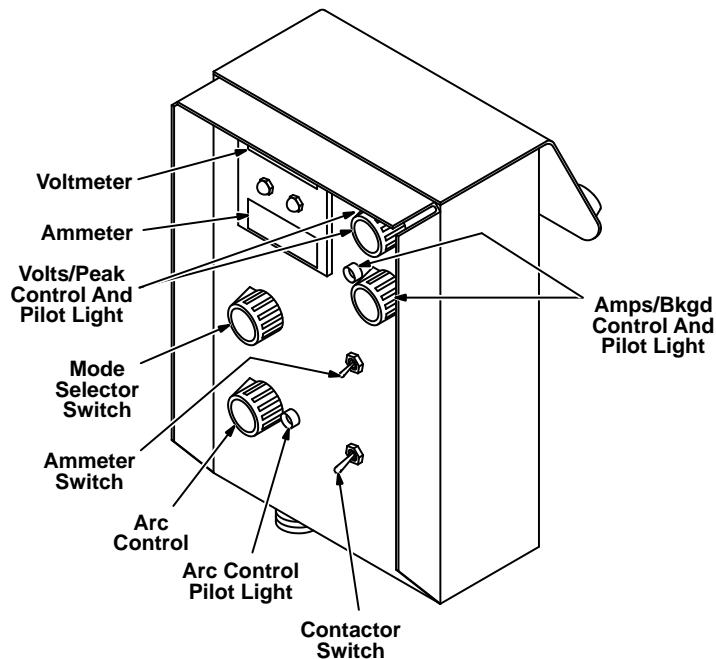

ST-109 521-A

Figure 3-1. Front Panel View

3-3. CONTACTOR SWITCH (Figure 3-1)



WARNING: ELECTRIC SHOCK can kill.

- Do not touch live electrical parts.
- Do not touch the weld output terminals when the contactor is energized.
- Do not touch electrode holder (or gun wire) and work clamp at the same time.

If the Remote Control CONTACTOR switch is in the ON position, open-circuit voltage will be present at the output terminals whenever the welding power source POWER switch ON button is depressed.

IMPORTANT: Although the term CONTACTOR is used on the nameplate and throughout this manual, the weld output is not switched on or off by a physical secondary contactor; rather, the weld output is controlled by solid-state circuitry in the welding power source.

If contactor control by means of a wire feeder is desired, place the Remote Control CONTACTOR switch in the OFF position. Open-circuit voltage will be present at the weld output terminals whenever the gun switch is closed.

The OFF position is normally used with all wire feeding processes (GMAW, GMAW-P, FCAW, SAW) and the Gas Tungsten Arc Welding (GTAW) process. The ON position is normally used with the Shielded Metal Arc Welding (SMAW) and the Air Carbon Arc (CAC-A) Cutting and gouging processes.

Lift end of toggle switch to change switch positions.

3-4. AMMETER SWITCH (Figure 3-1)

The AMMETER switch provides selection of reading PEAK weld amperage or Average (AVG) weld amperage on the Remote Control digital ammeter.

Normally the AVG switch position is used for reading weld amperage during Gas Metal Arc (GMAW), Flux Cored Arc (FCAW), Submerged Arc (SAW), Shielded Metal Arc (SMAW), Gas Tungsten Arc (GTAW) Welding and Air Carbon Arc (CAC-A) Cutting and gouging processes.

While welding using the Gas Metal Arc Welding - Pulsed Arc (GMAW-P) process, the AVG switch position is used when display of the average (background and peak) weld amperage is desired. The AMMETER switch can be placed in the PEAK position when display of peak weld amperage is desired.

3-5. AMPS/BKGD CONTROL AND PILOT LIGHT (Figure 3-1)

This control presets weld amperage for constant current applications and background amperage for GMAW-P applications.

When the Mode Selector switch is in the CC position or one of the pulses per second positions, the AMPS/BKGD pilot light turns on.

This control is disabled when the Mode Selector switch is in the CV position.

Rotating the control clockwise increases amperage.

IMPORTANT: The AMPS/BKGD control can be adjusted while welding.

3-6. VOLTS/PEAK CONTROL AND PILOT LIGHT (Figure 3-1)

This control presets weld voltage for constant voltage applications and peak voltage for GMAW-P applications.

When the Mode Selector switch is in the CV position or one of the pulses per second positions, the VOLTS/PEAK pilot light turns on.

This control is disabled when the Mode Selector switch is in the CC position.

Rotating the control clockwise increases voltage.

IMPORTANT: *The VOLTS/PEAK control can be adjusted while welding.*

3-7. METERS (Figure 3-1)

The voltmeter displays weld voltage to the nearest tenth of a volt while welding and preset voltage when unit is idling. When welding using the pulsed GMAW process, the meter displays peak voltage.

The ammeter displays weld amperage to the nearest ampere while welding and preset amperage when unit is idling. When welding using the pulsed GMAW process, the meter displays background amperage.

SECTION 4 – SEQUENCE OF OPERATION



WARNING: ELECTRIC SHOCK can kill; MOVING PARTS can cause serious injury; IMPROPER AIR FLOW AND EXPOSURE TO ENVIRONMENT can damage internal parts.

- *Keep all covers and panels in place while operating.*

Warranty is void if the welding power source is operated with any portion of the outer enclosure removed.

ARC RAYS, SPARKS, AND HOT SURFACES can burn eyes and skin; NOISE can damage hearing.

- *Wear correct eye, ear, and body protection.*

FUMES AND GASES can seriously harm your health.

- *Use enough ventilation to keep fumes and gases from the breathing zone.*

WELDING WIRE can cause puncture wounds.

- *Do not point gun toward any part of the body or other personnel.*

HOT METAL, SPATTER, AND SLAG can cause fire and burns.

- *Watch for fire.*
- *Have a fire extinguisher nearby and know how to use it.*

MAGNETIC FIELDS FROM HIGH CURRENTS can affect pacemaker operation.

- *Wearers should consult with their doctor before going near arc welding, gouging, or spot welding operations.*

See Arc Welding Safety Precautions Section in the welding power source Owner's Manual.

4-1. GAS METAL ARC WELDING - PULSED ARC (GMAW-P)



WARNING: Read and follow safety information at beginning of entire Section 4 before proceeding.

1. Install and prepare welding power source according to its Owner's Manual.
2. Install Remote Control as instructed in Section 2.
3. Install and prepare wire feeder according to its Owner's Manual.
4. Wear dry insulating gloves and clothing, and wear welding helmet with proper filter lens according to ANSI Z49.1.
5. Prepare for welding as follows:
 - a. Connect work clamp to clean, bare metal at workpiece.
 - b. Select and obtain proper welding wire, and thread as instructed in wire feeder Owner's Manual.
6. Depress welding power source POWER switch ON button.
7. Place Mode Selector switch to desired pulses per second (60, 90, 120, or 180) position (see Section 3-1).
8. Place CONTACTOR switch in OFF position (see Section 3-3).
9. Place AMMETER switch in the desired position (see Section 3-4).
10. Preset AMPS/BKGD control to desired background amperage setting (see Section 3-5). Pilot light should be on.

11. Preset VOLTS/PEAK control to desired peak voltage setting (see Section 3-6). Pilot light should be on.
12. Make adjustments to wire feeder.
13. Turn on shielding gas supply.
14. Begin welding.

4-2. GAS METAL ARC AND FLUX CORED ARC WELDING (GMAW AND FCAW)



WARNING: Read and follow safety information at beginning of entire Section 4 before proceeding.

1. Install and prepare welding power source according to its Owner's Manual.
2. Install Remote Control as instructed in Section 2.
3. Install and prepare wire feeder according to its Owner's Manual.
4. Wear dry insulating gloves and clothing, and wear welding helmet with proper filter lens according to ANSI Z49.1.
5. Prepare for welding as follows:
 - a. Connect work clamp to clean, bare metal at workpiece.
 - b. Select and obtain proper welding wire, and thread as instructed in wire feeder Owner's Manual.
6. Depress welding power source POWER switch ON button.
7. Place Mode Selector switch in CV position (see Section 3-1).
8. Place CONTACTOR switch in OFF position (see Section 3-3).
9. Place AMMETER switch in AVG (Average) position (see Section 3-4).
10. Preset VOLTS/PEAK control to desired weld voltage setting (see Section 3-6). Pilot light should be on.
11. Make adjustments to wire feeder.
12. Turn on shielding gas supply if applicable.
13. Begin welding.

4-3. SHIELDED METAL ARC WELDING (SMAW)



WARNING: Read and follow safety information at beginning of entire Section 4 before proceeding.

1. Install and prepare welding power source according to its Owner's Manual.
2. Install Remote Control as instructed in Section 2.
3. Depress welding power source POWER switch ON button.

4. Place Mode Selector switch in CC position (see Section 3-1).
5. Place ARC CONTROL to desired position (see Section 3-2). Pilot light should be on.
6. Place CONTACTOR switch in ON position (see Section 3-3).
7. Place AMMETER switch in AVG (Average) position (see Section 3-4).
8. Preset AMPS/BKGD control to desired weld amperage setting (see Section 3-5). Pilot light should be on.
9. Wear dry insulating gloves and clothing, and wear welding helmet with proper filter lens according to ANSI Z49.1.
10. Prepare for welding as follows:
 - a. Connect work clamp to clean, bare metal at workpiece.
 - b. Select and obtain proper electrode, and insert into electrode holder.
11. Begin welding.

4-4. SUBMERGED ARC WELDING (SAW)



WARNING: Read and follow safety information at beginning of entire Section 4 before proceeding.

1. Install and prepare welding power source according to its Owner's Manual.
2. Install Remote Control as instructed in Section 2.
3. Install flux system according to its Owner's Manual.
4. Install and prepare wire feeder according to its Owner's Manual.
5. Wear dry insulating gloves and clothing, and wear safety goggles with correct filter shade according to ANSI Z49.1.
6. Prepare for welding as follows:
 - a. Connect work clamp to clean, bare metal at workpiece.
 - b. Select and obtain proper welding wire, and thread as instructed in wire feeder Owner's Manual.
 - c. Select and obtain proper flux, and put into flux system.
7. Depress welding power source POWER switch ON button.
8. Place Mode Selector switch in CV position (see Section 3-1).
9. Place CONTACTOR switch in OFF position (see Section 3-3).
10. Place AMMETER switch in AVG (Average) position (see Section 3-4).
11. Preset VOLTS/PEAK control to desired weld voltage setting (see Section 3-6). Pilot light should be on.

12. Make adjustments to wire feeder.
13. Turn on flux supply system.
14. Begin welding.

4-5. GAS TUNGSTEN ARC WELDING (GTAW)



WARNING: Read and follow safety information at beginning of entire Section 4 before proceeding.

1. Install and prepare welding power source according to its Owner's Manual.
2. Install Remote Control as instructed in Section 2.
3. Install and prepare High-Frequency unit according to its Owner's Manual if applicable. Scratch start GTAW does not require the use of external high frequency.
4. Depress welding power source POWER switch ON button.
5. Place Mode Selector switch in CC position (see Section 3-1).
6. Set ARC CONTROL to MIN. (see Section 3-2). Pilot light should be on.
7. Place CONTACTOR switch in ON position (see Section 3-3).
8. Place AMMETER switch in AVG (Average) position (see Section 3-4).
9. Preset AMPS/BKGD control to desired weld amperage setting (see Section 3-5). Pilot light should be on.
10. Wear dry insulating gloves and clothing, and wear welding helmet with proper filter lens according to ANSI Z49.1.
11. Prepare for welding as follows:
 - a. Connect work clamp to clean, bare metal at workpiece.
 - b. Select and obtain proper tungsten electrode.
 - c. Prepare tungsten electrode according to welding power source Owner's Manual, and insert into torch.
12. Turn on shielding gas and water supplies as applicable.
13. Turn on and adjust High-Frequency unit if applicable.
14. Begin welding.

4-6. AIR CARBON ARC CUTTING AND GOUGING (CAC-A)



WARNING: Read and follow safety information at beginning of entire Section 4 before proceeding.

1. Install and prepare welding power source according to its Owner's Manual.
2. Install Remote Control as instructed in Section 2.
3. Connect compressed air supply.
4. Depress welding power source POWER switch ON button.
5. Place Mode Selector switch in CC position (see Section 3-1).
6. Set ARC CONTROL to desired position (see Section 3-2). Pilot light should be on.
7. Place CONTACTOR switch in ON position (see Section 3-3).
8. Place AMMETER switch in AVG (Average) position (see Section 3-4).
9. Preset AMPS/BKGD control to desired amperage setting (see Section 3-5). Pilot light should be on.
10. Wear dry insulating gloves and clothing, and wear welding helmet with proper filter lens according to ANSI Z49.1.
11. Prepare for welding as follows:
 - a. Connect work clamp to clean, bare metal at workpiece.
 - b. Select and obtain proper carbon electrode, and insert into torch.
12. Turn on air supply.
13. Begin cutting/gouging process.

4-7. SHUTTING DOWN

1. Stop welding.
2. Depress the welding power source POWER switch OFF button.
3. Turn off the shielding gas and water supplies if applicable.



WARNING: HIGH CONCENTRATION OF SHIELDING GASES can harm health or kill.

- Shut off gas supply when not in use.

4. Turn off flux supply and compressed air supply if applicable.

SECTION 5 – MAINTENANCE & TROUBLESHOOTING

5-1. MAINTENANCE

Usage and shop conditions will determine the frequency and type of maintenance. Inspect equipment as follows:



WARNING: ELECTRIC SHOCK can kill.

- Do not touch live electrical parts.
- Shut down welding power source, and disconnect remote control before inspecting, maintaining, or servicing unit. Power to the remote control should be disconnected before attempting repair or replacement of internal components.

1. Inspect interconnecting cord for damage to or breaks in the insulation jacket, particularly at the plugs. Repair or replace cord as necessary.
2. Remove grease and grime from components; moisture from electrical parts and cable.

5-2. TROUBLESHOOTING



WARNING: ELECTRIC SHOCK can kill.

- Do not touch live electrical parts.
- Shut down welding power source, and disconnect remote control before inspecting, maintaining, or servicing unit. Power to the remote control should be disconnected before attempting repair or replacement of internal components.



CAUTION: ELECTROSTATIC DISCHARGE (ESD) can damage circuit boards.

- Put on properly grounded wrist strap BEFORE handling circuit boards.
- Transport circuit boards in proper static-shielding carriers or packages.
- Perform work only at a static-safe work area.

INCORRECT INSTALLATION or misaligned plugs can damage circuit board.

- Be sure that plugs are properly installed and aligned.

EXCESSIVE PRESSURE can break circuit board.

- Use only minimal pressure and gentle movement when disconnecting or connecting board plugs and removing or installing board.

A. General

It is assumed that proper installation has been made, according to Section 2 of this manual, and that the unit has been functioning properly until trouble developed.

B. Troubleshooting

Troubleshooting to be performed only by qualified persons.

The following information is supplied to diagnose and provide remedies for some of the troubles that may develop in this unit. Check welding power source Owner's Manual for possible problems caused by welding power source malfunctions.

Use this information in conjunction with the circuit diagram while performing troubleshooting procedures. If the trouble is not remedied after performing these procedures, the nearest Factory Authorized Service Station/Service Distributor should be contacted. In all cases of equipment malfunction, the manufacturer's recommendations should be strictly followed.

Problems with this unit fall into four categories:

1. Front panel components
2. Circuit board PC5
3. Interconnecting cable
4. Welding power source.

If everything on the remote control functions except a particular switch, meter, or control, the problem can be attributed to a broken component. Replace the broken component.

If the problem is still present, replace PC5. If the remote control is entirely non-functional, replace PC5. If erratic conditions occur and the welding power source was working properly, replace PC5.

A break in the interconnecting cable can interrupt power or command signal between welding power source and remote control. Replace interconnecting cable if lack of continuity is suspected.

Printed circuit board PC1 in the welding power source sends and receives signals from the remote control. If all other components of the system are functioning, replace welding power source PC1 according to instructions in welding power source Owner's Manual.

SECTION 6 – ELECTRICAL DIAGRAMS

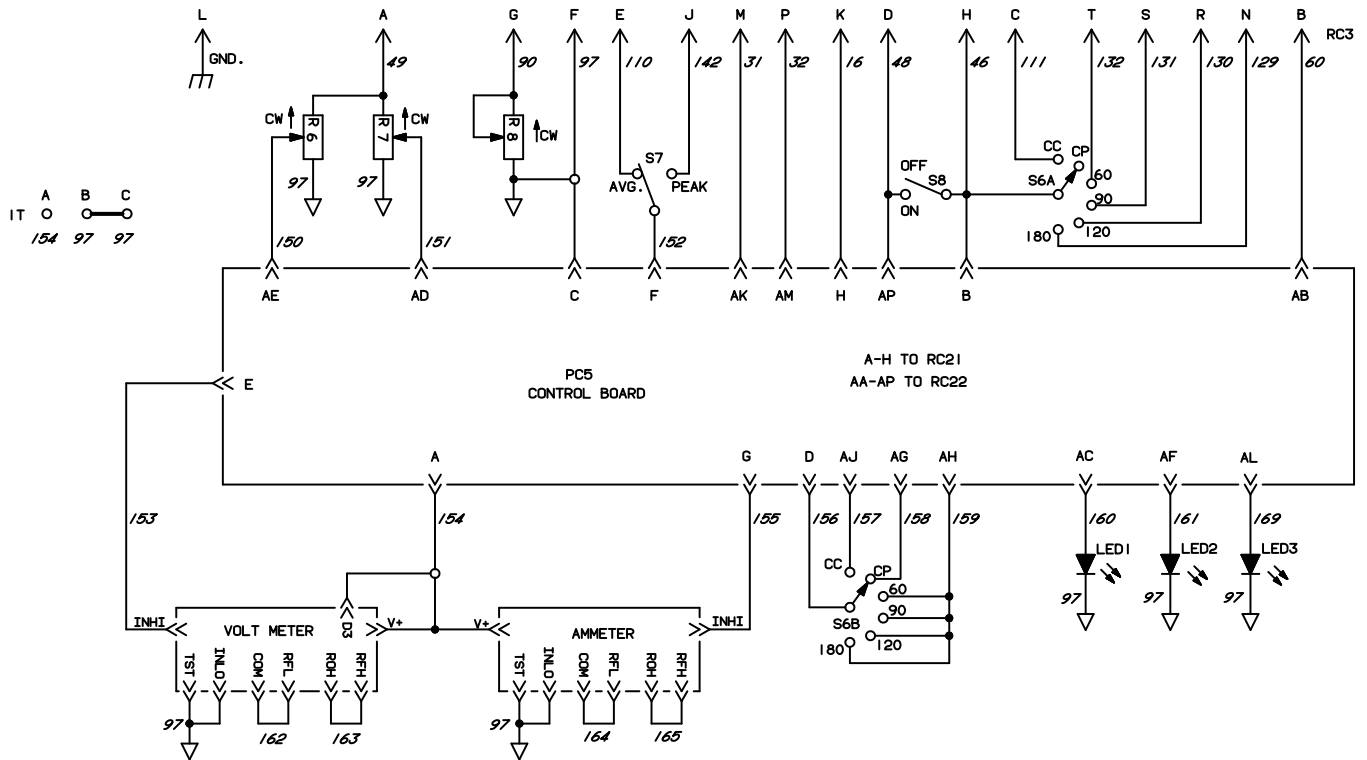

Circuit Diagram No. SB-107 993-B

Diagram 6-1. Circuit Diagram For Pendant Control

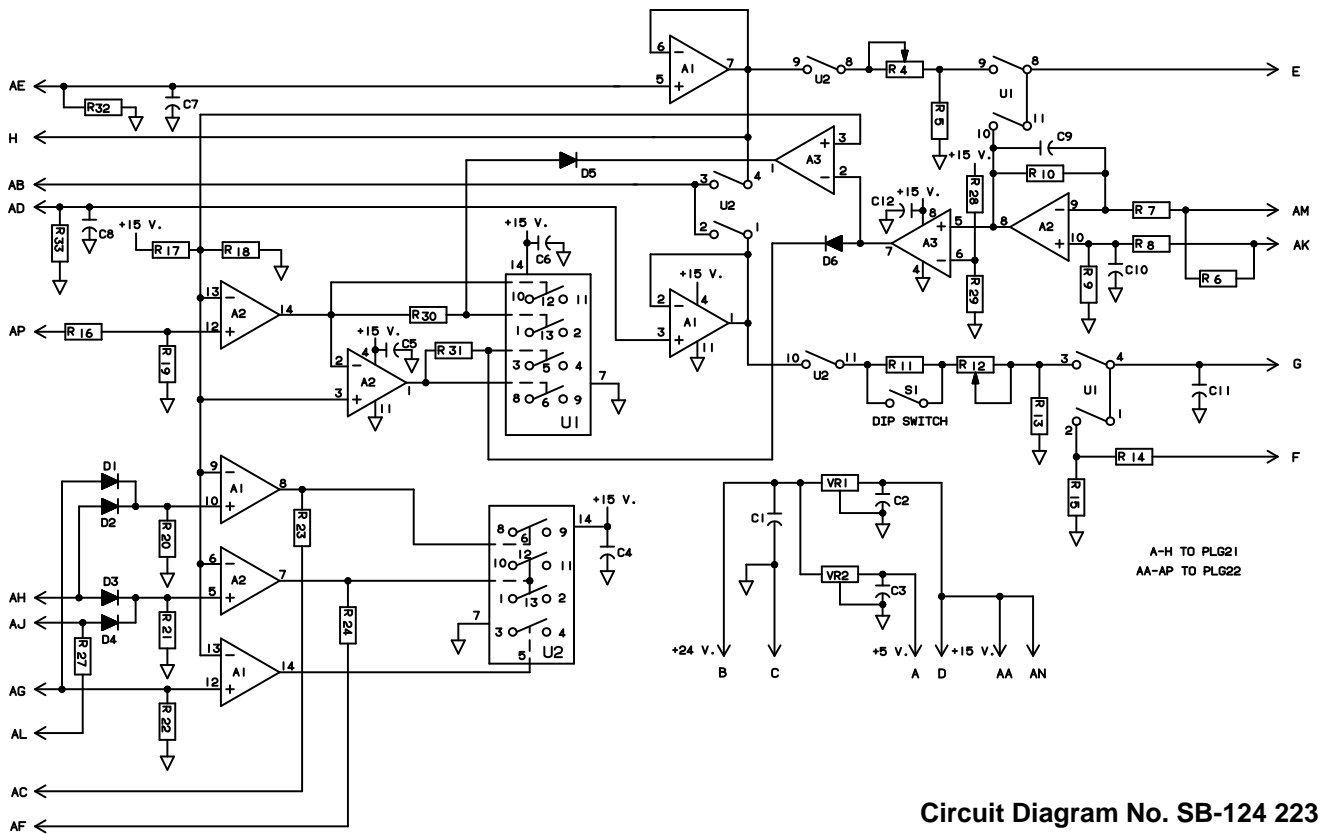

Circuit Diagram No. SB-124 223

Diagram 6-2. Circuit Diagram For Circuit Board PC5

SECTION 7 – PARTS LIST

Item No.	Dia. Mkgs.	Part No.	Description	Quantity
Figure 7-1. Main Assembly				
1		108 056	CASE SECTION, front end	1
2		109 779	CASE	1
3	R6,7	603 856	POTENTIOMETER, WW 10 turn 2 watt 10K ohm	2
4	S7	011 770	SWITCH, toggle SPDT 5 amp 125 volts	1
5	S8	079 722	SWITCH, toggle SPDT 0.4 amp 2-4 volts dc	1
6	LED1-3	083 850	LIGHT, indicator - red lens 2 volts	3
7	RC3	097 867	RECEPTACLE, 17 pin MS-3102A-20-29P	1
8			NAMEPLATE (order by model & style number)	1
9	R8	009 156	POTENTIOMETER, carbon 1 turn 2 watt 2.5K ohm	1
10	S6	108 944	SWITCH, rotary - 0.5 amp 115 volts ac	1
11		108 903	SHIELD, meter	1
12	A&V	108 453	METER, DC 0-200 MV	2
		108 904	ANCHOR, meter	1
	PC5	124 002	CIRCUIT CARD, pendant	1
		038 785	STRIP, terminal 3 pole	1
		072 566	CONNECTOR, rect 8skt plug Amp 87159-8	1
		081 380	CONNECTOR, rect 14skt plug Amp 1-87159-3	1
		108 907	CONNECTOR, rect 13skt 1 row plug Amp 2-87499-3	2
		097 922	KNOB, pointer	4
		019 663	MOUNT, 15/16 OD x 3/8	2
		097 132	STAND-OFF, No. 6-32 x 3/8 inches	4
		094 484	STAND-OFF, No. 6-32 x 1 inch	4
		108 863	CABLE, interconnecting (consisting of)	1
		097 868	CONNECTOR, circ 17skt plug Amphenol MS-3106A-20-29S	1
		039 734	CONNECTOR, circ clamp str rlf Amphenol AN-3057-12	2
		090 263	CABLE, pwr No. 18ga 18/c (order by ft)	15ft
		097 866	CONNECTOR, circ 17 pin plug Amphenol MS-3106A-20-29P	1

 Hardware is common and not available unless listed.

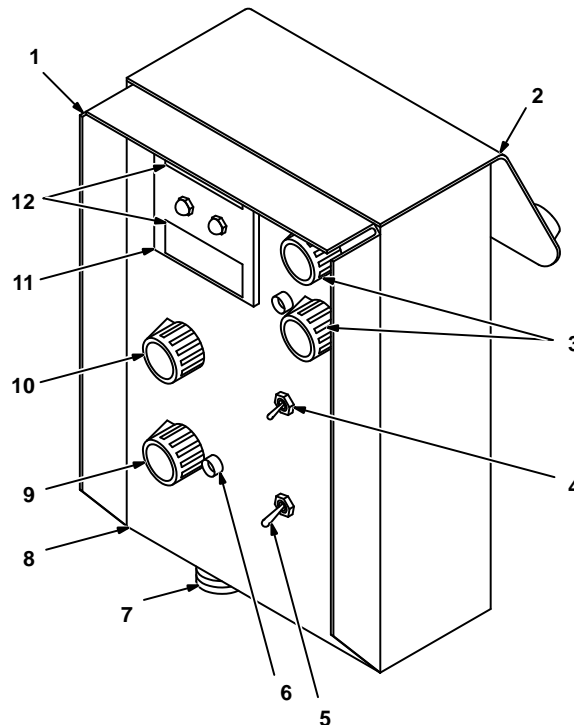

Figure 7-1. Main Assembly

ST-109 521

To maintain the factory original performance of your equipment, use only Manufacturer's Suggested Replacement Parts. Model and serial number required when ordering parts from your local distributor.

Free Manuals Download Website

<http://myh66.com>

<http://usermanuals.us>

<http://www.somanuals.com>

<http://www.4manuals.cc>

<http://www.manual-lib.com>

<http://www.404manual.com>

<http://www.luxmanual.com>

<http://aubethermostatmanual.com>

Golf course search by state

<http://golfingnear.com>

Email search by domain

<http://emailbydomain.com>

Auto manuals search

<http://auto.somanuals.com>

TV manuals search

<http://tv.somanuals.com>