



**OPERATOR'S MANUAL  
MANUEL de L'UTILISATEUR  
MANUAL del OPERADOR**

**Catalog No.  
No de Cat.  
Catálogo No.**

**1670-1**

**1675-1**

**1675-6**

**1676-6**

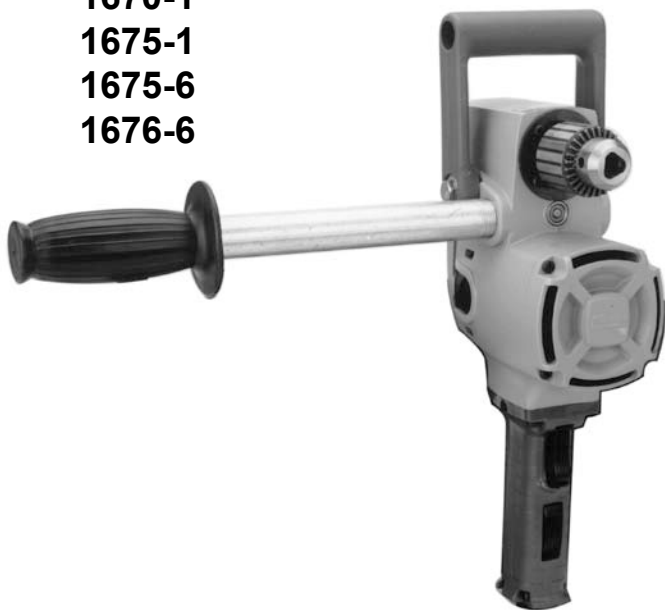

**HEAVY-DUTY HOLE HAWG®**

**FOREUSE EXTRA-ROBUSTE HOLE HAWG®**

**TALADRO HEAVY-DUTY HOLE HAWG®**

***TO REDUCE THE RISK OF INJURY, USER MUST READ OPERATOR'S MANUAL.  
AFIN DE RÉDUIRE LE RISQUE DE BLESSURES, L'UTILISATEUR DOIT LIRE LE  
MANUEL DE L'UTILISATEUR.***

***PARA REDUCIR EL RIESGO DE LESIONES, EL USUARIO DEBE LEER EL MANUAL  
DEL OPERADOR.***

## GENERAL SAFETY RULES-FOR ALL BATTERY OPERATED TOOLS



### WARNING

#### READ ALL INSTRUCTIONS

Failure to follow all instructions listed below may result in electric shock, fire and/or serious injury. The term "power tool" in all of the warnings listed below refers to your mains-operated (corded) power tool or battery-operated (cordless) power tool.

#### SAVE THESE INSTRUCTIONS

### WORK AREA SAFETY

1. **Keep work area clean and well lit.** Cluttered or dark areas invite accidents.
2. **Do not operate power tools in explosive atmospheres, such as in the presence of flammable liquids, gases, or dust.** Power tools create sparks which may ignite the dust or fumes.
3. **Keep children and bystanders away while operating a power tool.** Distractions can cause you to lose control.

### ELECTRICAL SAFETY

4. **Power tool plugs must match the outlet. Never modify the plug in any way. Do not use any adapter plugs with earthed (grounded) power tools.** Unmodified plugs and matching outlets will reduce risk of electric shock.
5. **Avoid body contact with earthed or grounded surfaces such as pipes, radiators, ranges and refrigerators.** There is an increased risk of electric shock if your body is earthed or grounded.
6. **Do not expose power tools to rain or wet conditions.** Water entering a power tool will increase the risk of electric shock.
7. **Do not abuse the cord. Never use the cord for carrying, pulling, or unplugging the power tool. Keep cord away from heat, oil, sharp edges, or moving parts.** Damaged or entangled cords increase the risk of electric shock.
8. **When operating a power tool outdoors, use an extension cord suitable for outdoor use.** Use of a cord suitable for outdoor use reduces the risk of electric shock.

### PERSONAL SAFETY

9. **Stay alert, watch what you are doing and use common sense when operating a power tool. Do not use a power tool while you are tired or under the influence of drugs, alcohol or medication.** A moment of inattention while operating power tools may result in serious personal injury.
10. **Use safety equipment. Always wear eye protection.** Safety equipment such as dust mask, non-skid safety shoes, hard hat, or hearing protection used for appropriate conditions will reduce personal injuries.
11. **Avoid accidental starting. Ensure the switch is in the off-position before plugging in.** Carrying tools with your finger on the switch or plugging in power tools that have the switch on invites accidents.
12. **Remove any adjusting key or wrench before turning the power tool on.** A wrench or a key left attached to a rotating part of the power tool may result in personal injury.
13. **Do not overreach. Keep proper footing and balance at all times.** This enables better control of the power tool in unexpected situations.
14. **Dress properly. Do not wear loose clothing or jewellery. Keep your hair, clothing and gloves away from moving parts.** Loose clothes, jewellery, or long hair can be caught in moving parts.
15. **If devices are provided for the connection of dust extraction and collection facilities, ensure these are connected and properly used.** Use of these devices can reduce dust-related hazards.

## POWER TOOL USE AND CARE

16. **Do not force the power tool. Use the correct power tool for your application.** The correct power tool will do the job better and safer at the rate for which it was designed.
17. **Do not use the power tool if the switch does not turn it on and off.** Any power tool that cannot be controlled with the switch is dangerous and must be repaired.
18. **Disconnect the plug from the power source and/or the battery pack from the power tool before making any adjustments, changing accessories, or storing power tools.** Such preventive safety measures reduce the risk of starting the tool accidentally.
19. **Store idle power tools out of the reach of children and do not allow persons unfamiliar with the power tools or these instructions to operate power tools.** Power tools are dangerous in the hands of untrained users.
20. **Maintain power tools. Check for misalignment or binding of moving parts, breakage of parts and any other condition that may affect the power tool's operation. If damaged, have the power tool repaired before use.** Many accidents are caused by poorly maintained power tools.
21. **Keep cutting tools sharp and clean.** Properly maintained cutting tools with sharp cutting edges are less likely to bind and are easier to control.
22. **Use the power tool, accessories and tool bits etc., in accordance with these instructions and in the manner intended for the particular type of power tool, taking into account the working conditions and the work to be performed.** Use of the power tool for operations different from those intended could result in a hazardous situation.

### SERVICE

23. **Have your power tool serviced by a qualified repair person using only identical replacement parts.** This will ensure that the safety of the power tool is maintained.

## SPECIFIC SAFETY RULES

1. **Use auxiliary handles supplied with the tool.** Loss of control can cause personal injury.
2. **Wear ear protectors with impact drills.** Exposure to noise can cause hearing loss.
3. **Hold power tools by insulated gripping surfaces when performing an operation where the cutting tool may contact hidden wiring or its own cord.** Contact with a "live" wire will make exposed metal parts of the tool "live" and shock the operator.
4. **Maintain labels and nameplates.** These carry important information. If unreadable or missing, contact a MILWAUKEE service facility for a free replacement.
5. **WARNING!** Some dust created by power sanding, sawing, grinding, drilling, and other construction activities contains chemicals known to cause cancer, birth defects or other reproductive harm. Some examples of these chemicals are:
  - lead from lead-based paint
  - crystalline silica from bricks and cement and other masonry products, and
  - arsenic and chromium from chemically-treated lumber.Your risk from these exposures varies, depending on how often you do this type of work. To reduce your exposure to these chemicals: work in a well-ventilated area, and work with approved safety equipment, such as those dust masks that are specifically designed to filter out microscopic particles.

## FUNCTIONAL DESCRIPTION

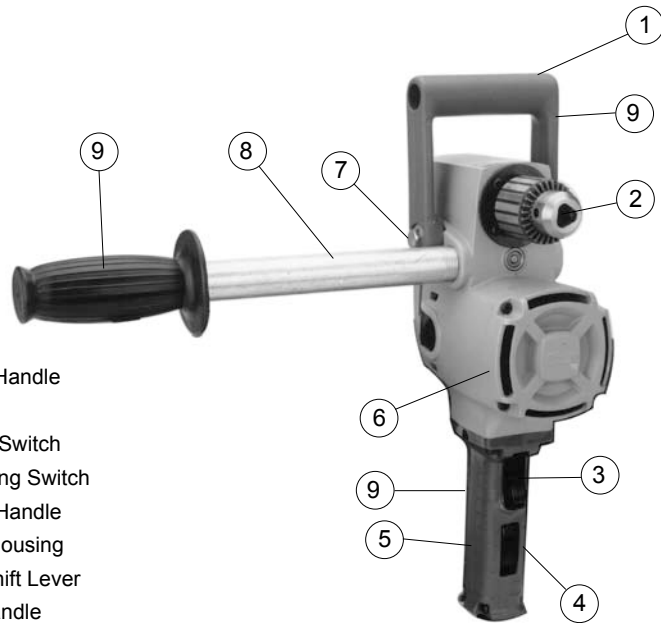

1. Spade Handle
2. Chuck
3. Trigger Switch
4. Reversing Switch
5. Switch Handle
6. Motor Housing
7. Gear Shift Lever
8. Pipe Handle
9. Insulated Gripping Surfaces

## Symbology

	Underwriters Laboratories, Inc.
	Canadian Standards Association
	Mexican Approvals Marking
	Volts Alternating Current
$n_0 \text{xxxx} / \text{min.}$	No Load Revolutions per Minute (RPM)
<b>A</b>	Amperes

## Specifications

Cat. No.	Volts AC	Speed	No Load RPM	Capacity			
				Steel With Twist Bit	Wood With Auger Bit	Wood With Ship Auger Bit	Wood With Selffeed Bit
1670-1	120	-	900	7/16"	1-1/2"	1-1/2"	2-9/16"
1675-1	120	High	1200	5/16"	1-1/8"	1-1/4"	1-3/8"
		Low	300	1/2"	1-1/2"	1-1/2"	4-5/8"
1675-6	120	High	1200	5/16"	1-1/8"	1-1/4"	1-3/8"
		Low	300	1/2"	1-1/2"	1-1/2"	4-5/8"
1676-6	120	High	1200	5/16"	1-1/8"	1-1/4"	1-3/8"
		Low	300	1/2"	1-1/2"	1-1/2"	4-5/8"

## GROUNDING



### WARNING

Improperly connecting the grounding wire can result in the risk of electric shock. Check with a qualified electrician if you are in doubt as to whether the outlet is properly grounded. Do not modify the plug provided with the tool. Never remove the grounding prong from the plug. Do not use the tool if the cord or plug is damaged. If damaged, have it repaired by a MILWAUKEE service facility before use. If the plug will not fit the outlet, have a proper outlet installed by a qualified electrician.

### Grounded Tools: Tools with Three Prong Plugs

Tools marked "Grounding Required" have a three wire cord and three prong grounding plug. The plug must be connected to a properly grounded outlet (See Figure A). If the tool should electrically malfunction or break down, grounding provides a low resistance path to carry electricity away from the user, reducing the risk of electric shock.

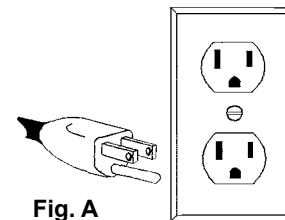

Fig. A

The grounding prong in the plug is connected through the green wire inside the cord to the grounding system in the tool. The green wire in the cord must be the only wire connected to the tool's grounding system and must never be attached to an electrically "live" terminal.

Your tool must be plugged into an appropriate outlet, properly installed and grounded in accordance with all codes and ordinances. The plug and outlet should look like those in Figure A.

### Double Insulated Tools: Tools with Two Prong Plugs

Tools marked "Double Insulated" do not require grounding. They have a special double insulation system which satisfies OSHA requirements and complies with the applicable standards of Underwriters Laboratories, Inc., the Canadian Standard Association and the National Electrical Code. Double Insulated tools may be used in either of the 120 volt outlets shown in Figures B and C.

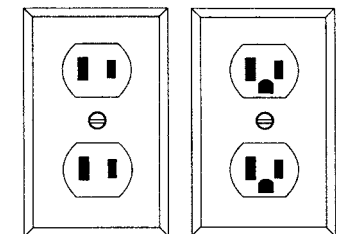

Fig. B

Fig. C

## EXTENSION CORDS

Grounded tools require a three wire extension cord. Double insulated tools can use either a two or three wire extension cord. As the distance from the supply outlet increases, you must use a heavier gauge extension cord. Using extension cords with inadequately sized wire causes a serious drop in voltage, resulting in loss of power and possible tool damage. Refer to the table shown to determine the required minimum wire size.

The smaller the gauge number of the wire, the greater the capacity of the cord. For example, a 14 gauge cord can carry a higher current than a 16 gauge cord. When using more than one extension cord to make up the total length, be sure each cord contains at least the minimum wire size required. If you are using one extension cord for more than one tool, add the nameplate amperes and use the sum to determine the required minimum wire size.

### Guidelines for Using Extension Cords

- If you are using an extension cord outdoors, be sure it is marked with the suffix "W-A" ("W" in Canada) to indicate that it is acceptable for outdoor use.
- Be sure your extension cord is properly wired and in good electrical condition. Always replace a damaged extension cord or have it repaired by a qualified person before using it.
- Protect your extension cords from sharp objects, excessive heat and damp or wet areas.

### Recommended Minimum Wire Gauge for Extension Cords\*

Nameplate Amperes	Extension Cord Length				
	25'	50'	75'	100'	150'
0 - 2.0	18	18	18	18	16
2.1 - 3.4	18	18	18	16	14
3.5 - 5.0	18	18	16	14	12
5.1 - 7.0	18	16	14	12	12
7.1 - 12.0	16	14	12	10	
12.1 - 16.0	14	12	10		
16.1 - 20.0	12	10			

\* Based on limiting the line voltage drop to five volts at 150% of the rated amperes.

**READ AND SAVE ALL INSTRUCTIONS FOR FUTURE USE.**

## TOOL ASSEMBLY



### WARNING

To reduce the risk of injury, always unplug tool before attaching or removing accessories or making adjustments. Use only specifically recommended accessories. Others may be hazardous.

### Installing Bits into Keyed Chucks (Fig.1)

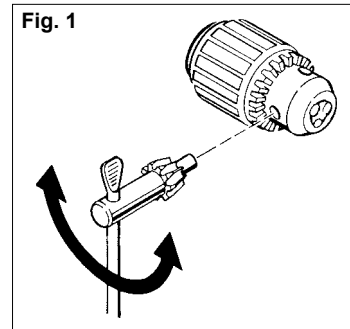

1. Unplug tool.
2. Open the chuck jaws wide enough to insert the bit. Be sure the bit shank and chuck jaws are clean. Dirt particles may prevent the bit from lining up properly.
3. Insert the bit into the chuck. Center the bit in the chuck jaws and lift it about 1/16" off of the bottom. Then, tighten the chuck jaws by hand to align the bit.
4. Place the chuck key in each of the three holes in the chuck, turning it clockwise. Tighten securely.
5. To remove the bit, insert the chuck key into one of the holes in the chuck and turn it counterclockwise.

### Bit Selection

- Use sharp bits. Sharp bits are less likely to bind when drilling.
- Use the proper bit for the job. There are many types of bits designed for specific purposes. Check the information on the bit's packaging for proper usage.
- Do not use bits larger than the rated capacity of the drill. Gear damage or motor overload may result.

### Pipe Handle

The pipe handle may be used on either side of the tool. Thread pipe handle into one of the threaded holes in the motor housing.

### Spade Handle (Fig. 2)

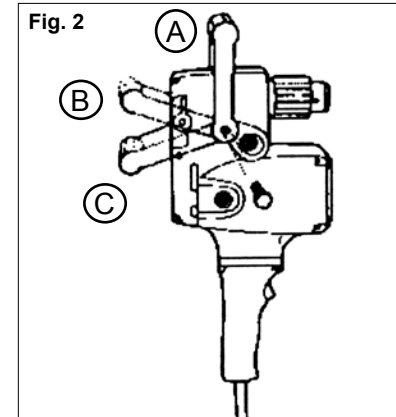

The spade handle can be attached to the tool in three positions (Fig. 2). Remove the hex head screws which secure the handle. Remove the handle and move it to the desired position. To mount the handle in position C, it is necessary to reverse the mounting holes by turning the handle around.

## OPERATION

### WARNING

To reduce the risk of injury, wear safety goggles or glasses with side shields. Unplug the tool before changing accessories or making adjustments.

### WARNING

To reduce the risk of personal injury when drilling, always hold tool by the insulated gripping surfaces when performing an operation where the cutting tool may contact hidden wiring or its own cord. Contact with a "live" wire will make exposed metal parts of the tool "live" and shock the operator.

### WARNING

When drilling with a single speed drill or in HI with a two speed drill, always hold the drill securely using the pipe handle, or brace the drill against a solid fixed object in preparation for a sudden reaction. When drilling in LO with a two speed drill, always brace the drill against a solid fixed object in preparation for a sudden reaction.

When drilling, never use your body to brace drill.

Never put your hands (or other body parts) between the part of the drill being braced and the object it is being braced against. Hands (or other body parts) that are in the path of the reaction can be pinched, crushed and broken.

### Bit binding (Fig. 3)

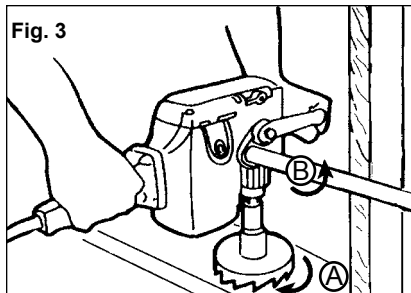

If the bit binds, the drill will suddenly react in the opposite direction of the rotation of the bit. Figure 3 shows the path of reaction (B) if the drill bit binds while being driven in forward (A). The operator should reduce the chances of a sudden reaction by following the instructions listed below.

The operator should also prepare for a sudden reaction by holding securely using the pipe handle or bracing against a solid fixed object.

#### To reduce the chance of bit binding

- Use sharp bits. Sharp bits are less likely to bind when drilling.
- Use the proper bit for the job. There are many types of bits designed for specific purposes.
- Use the proper speed for the size bit. Larger bits should be run at the lower speed. Driving larger bits at high speeds will increase the chance of the bit binding and increase the chance of reaction.
- Avoid drilling warped, wet, knotty, and or pitchy material if possible.
- Avoid drilling in material that you suspect contains hidden nails or other things that may cause the bit to bind.

The direction of reaction is always opposite of the direction of bit rotation.

Reaction is even more likely to occur when enlarging already existing holes and at the point when the bit breaks through the other side of the material.

### Bracing for forward rotation

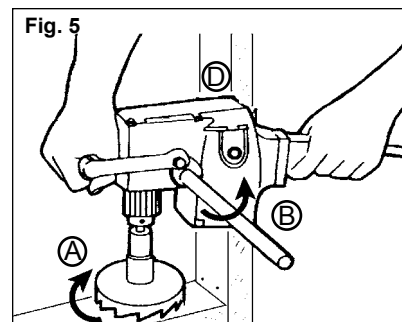
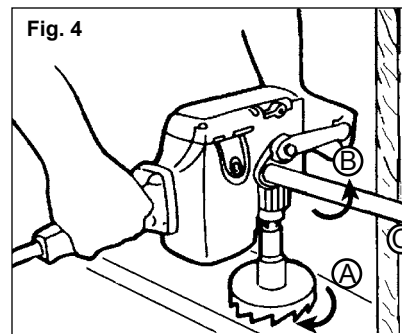

When drilling in forward, the bit will **rotate** in a clockwise direction. If the bit binds in the hole, the bit will come to a sudden stop and drill will suddenly **react** in a counterclockwise direction.

Figures 4 and 5 show examples of a Hole Hawg® properly braced for forward rotation.

- A. Forward (clockwise) rotation
- B. Reaction
- C. Brace drill with pipe handle here
- D. Brace drill with motor housing here

If the bit binds, the pipe handle or the motor housing braced against the stud will hold the drill in position.

### Bracing for reverse rotation

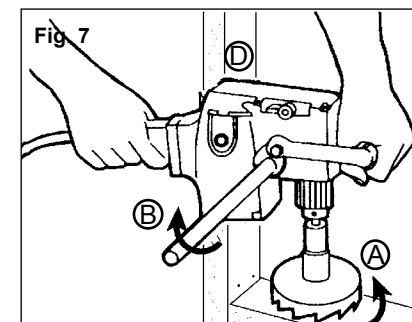
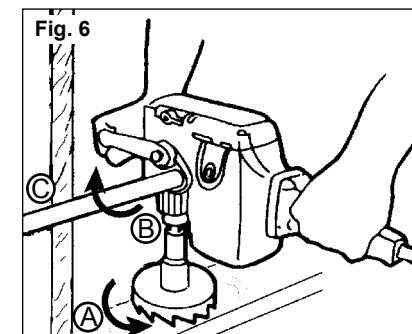

When drilling in reverse, the bit will **rotate** in a counterclockwise direction. If the bit binds in the hole, the bit will come to a sudden stop and the drill will suddenly **react** in a clockwise direction.

Figures 6 and 7 show examples of the Hole Hawg® properly braced for reverse rotation.

- A. Reverse (counterclockwise) rotation
- B. Reaction
- C. Brace drill with pipe handle here
- D. Brace drill with motor housing here

If the bit binds, the pipe handle or the motor housing braced against the stud will hold the drill in position.

### Shifting Speeds (Fig. 8)

Cat. No. 1675-1 has a gear shift lever on the right side of the gear case.

The high setting (1200 RPM HI) is the low torque setting and is designed for driving Selfeed bits 1-3/8" in diameter and smaller.

The low setting (300 RPM LO) is the high torque setting and is designed for driving Selfeed bits 1-1/2" in diameter and larger.

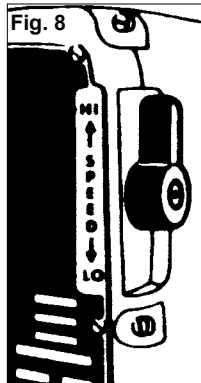

### Reversing (Fig. 9)

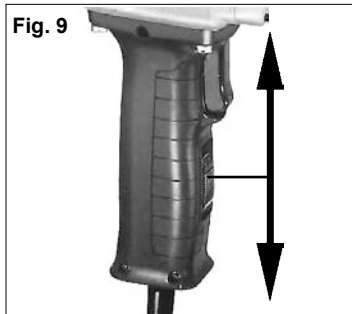

A reversing switch is located below the trigger switch for removal of bits from holes. Permit the motor to come to a complete stop before reversing. Reversing the tool with the gears in motion may cause severe damage. When removing selfeed bits from partially drilled holes, a flick of the trigger switch will free the threaded pilot screw. When the threads are loose, lift the bit from the workpiece with the motor stopped.

### Drilling

Before drilling, clamp down the material securely. A poorly secured piece of material may result in personal injury or inaccurate drilling. When drilling in light gauge metal or wood, use a wooden block to back up the material to prevent damage to the workpiece.

Mark the center of the hole to be drilled with a center punch to give the bit a start and to prevent it from "walking." Lubricate the drill bit with cutting oil when drilling iron or steel. Use a coolant when drilling nonferrous metals such as copper, brass or aluminum.

To start a selfeed bit, run the threaded feed screw into the work by flicking the trigger switch, permitting the bit to coast until the teeth contact the work surface. Align the bit properly before proceeding. This will reduce cocking and jamming when starting. To reduce jamming on breakthrough, decrease the drilling pressure when the feed screw point breaks through the workpiece. Proceed with steady, even pressure.



### WARNING

To reduce the risk of injury, always wear eye protection.

### Chuck Removal

To remove the chuck from the drill:

1. Unplug tool.
2. Fully open the chuck jaws
3. Remove the left-handed thread screw from inside the chuck by turning it clockwise.
4. Pull the chuck off of the spindle.

**NOTE:** If the chuck does not pull off of the spindle easily, tap the side of the chuck with a hammer to loosen it. If this doesn't work, contact a *MILWAUKEE* service center.

## MAINTENANCE



### WARNING

To reduce the risk of injury, always unplug your tool before performing any maintenance. Never disassemble the tool or try to do any rewiring on the tool's electrical system. Contact a *MILWAUKEE* service facility for ALL repairs.



### WARNING

To reduce the risk of injury, electric shock and damage to the tool, never immerse your tool in liquid or allow a liquid to flow inside the tool.

### Cleaning

Clean dust and debris from vents. Keep the tool handles clean, dry and free of oil or grease. Use only mild soap and a damp cloth to clean your tool since certain cleaning agents and solvents are harmful to plastics and other insulated parts. Some of these include: gasoline, turpentine, lacquer thinner, paint thinner, chlorinated cleaning solvents, ammonia and household detergents containing ammonia. Never use flammable or combustible solvents around tools.

### Repairs

If your tool is damaged, return the entire tool to the nearest service center.

### Maintaining Tools

Keep your tool in good repair by adopting a regular maintenance program. Before use, examine the general condition of your tool. Inspect guards, switches, tool cord set and extension cord for damage. Check for loose screws, misalignment, binding of moving parts, improper mounting, broken parts and any other condition that may affect its safe operation. If abnormal noise or vibration occurs, turn the tool off immediately and have the problem corrected before further use. Do not use a damaged tool. Tag damaged tools "DO NOT USE" until repaired (see "Repairs").

Under normal conditions, relubrication is not necessary until the motor brushes need to be replaced. After six months to one year, depending on use, return your tool to the nearest *MILWAUKEE* service facility for the following:

- Lubrication
- Brush inspection and replacement
- Mechanical inspection and cleaning (gears, spindles, bearings, housing, etc.)
- Electrical inspection (switch, cord, armature, etc.)
- Testing to assure proper mechanical and electrical operation

## ACCESSORIES



### WARNING

To reduce the risk of injury, always unplug the tool before attaching or removing accessories. Use only specifically recommended accessories. Others may be hazardous.

For a complete listing of accessories refer to your MILWAUKEE Electric Tool catalog or go on-line to [www.milwaukeetool.com](http://www.milwaukeetool.com). To obtain a catalog, contact your local distributor or a service center.

#### Plastic Carrying Case

Cat. No. 48-55-0111

#### Type "E" Grease

Cat. No. 49-08-4122

#### Chuck Key Holder

Cat. No. 48-66-4040

#### Chuck Key

Cat. No. 48-66-3280

## FIVE YEAR TOOL LIMITED WARRANTY

Every MILWAUKEE tool is tested before leaving the factory and is warranted to be free from defects in material and workmanship. MILWAUKEE will repair or replace (at MILWAUKEE's discretion), without charge, any tool (including battery chargers) which examination proves to be defective in material or workmanship from five (5) years after the date of purchase. Return the tool and a copy of the purchase receipt or other proof of purchase to a MILWAUKEE Factory Service/Sales Support Branch location or MILWAUKEE Authorized Service Station, freight prepaid and insured. This warranty does not cover damage from repairs made or attempted by other than MILWAUKEE authorized personnel, abuse, normal wear and tear, lack of maintenance, or accidents.

The warranty period for V28 Battery Packs is two (2) years from the date of purchase. The warranty period for Ni-Cd battery Packs, Flashlights, Radios are warranted for one (1) year from the date of purchase.

THE REPAIR AND REPLACEMENT REMEDIES DESCRIBED HEREIN ARE EXCLUSIVE. IN NO EVENT SHALL MILWAUKEE BE LIABLE FOR ANY INCIDENTAL, SPECIAL, OR CONSEQUENTIAL DAMAGES, INCLUDING LOSS OF PROFITS.

THIS WARRANTY IS EXCLUSIVE AND IN LIEU OF ALL OTHER WARRANTIES, OR CONDITIONS, WRITTEN OR ORAL, EXPRESSED OR IMPLIED FOR MERCHANTABILITY OR FITNESS FOR PARTICULAR USE OR PURPOSE.

This warranty gives you specific legal rights. You may also have other rights that vary from state to state and province to province. In those states that do not allow the exclusion of implied warranties or limitation of incidental or consequential damages, the above limitations or exclusions may not apply to you. This warranty applies to the United States, Canada, and Mexico only.

## RÈGLES GÉNÉRALES DE SÉCURITÉ POUR LES OUTILS ALIMENTÉS PAR BATTERIE



### AVERTISSEMENT

#### LIRE SOIGNEUSEMENT TOUTES LES INSTRUCTIONS

Le non respect des instructions ci-après peut entraîner des chocs électriques, des incendies et/ou des blessures graves. Le terme «outil électrique» figurant dans les avertissements ci-dessous renvoie à l'outil électrique à alimentation par le réseau (à cordon) ou par batterie (sans fil).

#### CONSERVER CES INSTRUCTIONS

### SÉCURITÉ DU LIEU DE TRAVAIL

1. **Maintenir la zone de travail propre et bien éclairée.** Les zones encombrées ou mal éclairées sont favorables aux accidents.
2. **Ne pas utiliser d'outil électrique dans une atmosphère explosive, telle qu'en en présence de liquides, de gaz ou de poussières inflammables.** Les outils électriques génèrent des étincelles qui peuvent enflammer les poussières ou les fumées.
3. **Tenir les enfants et les personnes non autorisées à l'écart pendant le fonctionnement d'un outil électrique.** Un manque d'attention de l'opérateur risque de lui faire perdre le contrôle de l'outil.

### SÉCURITÉ ÉLECTRIQUE

4. **La fiche de l'outil électrique doit correspondre à la prise d'alimentation. Ne jamais modifier la fiche d'une manière quelconque. Ne pas utiliser d'adaptateur avec les outils électriques mis à la terre (à la masse).** Des fiches non modifiées et des prises d'alimentation assorties réduisent le risque de choc électrique.
5. **Éviter tout contact corporel avec des surfaces reliées à la masse ou à la terre telles que tuyaux, radiateurs, cuisinières et réfrigérateurs.** Un risque de choc électrique plus élevé existe si le corps est relié à la masse ou à la terre.
6. **Ne pas exposer les outils électriques à la pluie ou à l'humidité.** Le risque de choc électrique augmente si de l'eau s'infiltré dans un outil électrique.

7. **Prendre soin du cordon. Ne jamais utiliser le cordon pour transporter, tirer ou débrancher l'outil électrique. Tenir le cordon à l'écart de la chaleur, des huiles, des arêtes coupantes ou des pièces en mouvement.** Un cordon endommagé ou emmêlé présente un risque accru de choc électrique.
8. **Se procurer un cordon d'alimentation approprié en cas d'utilisation d'un outil électrique à l'extérieur.** L'utilisation d'un cordon d'alimentation pour usage extérieur réduit le risque de choc électrique.

### SÉCURITÉ INDIVIDUELLE

9. **Être sur ses gardes, être attentif et faire preuve de bon sens en utilisant un outil électrique. Ne pas utiliser un outil électrique en cas de fatigue ou sous l'influence de drogues, d'alcool ou de médicaments.** Un instant d'inattention lors de l'utilisation d'un outil électrique peut entraîner des blessures graves.
10. **Utiliser un équipement de sécurité. Toujours porter des lunettes de protection.** Un équipement de sécurité comprenant masque anti-poussière, chaussures de sécurité anti-dérapantes, casque ou dispositif de protection anti-bruit peut, dans les circonstances appropriées, réduire le risque de blessure.
11. **Éviter tout démarrage accidentel de l'outil. S'assurer que le commutateur est en position OFF (Arrêt) avant de brancher l'outil.** Le port de l'outil avec un doigt sur le commutateur ou son branchement avec le commutateur en position ON (Marche) sont favorables aux accidents.

## Free Manuals Download Website

<http://myh66.com>

<http://usermanuals.us>

<http://www.somanuals.com>

<http://www.4manuals.cc>

<http://www.manual-lib.com>

<http://www.404manual.com>

<http://www.luxmanual.com>

<http://aubethermostatmanual.com>

Golf course search by state

<http://golfingnear.com>

Email search by domain

<http://emailbydomain.com>

Auto manuals search

<http://auto.somanuals.com>

TV manuals search

<http://tv.somanuals.com>