



GAS-POWERED CUTOFF SAW

Item# 999000

OWNER'S MANUAL



Read carefully and understand RULES FOR SAFE OPERATION and instructions before operating. Failure to follow the safety rules and other basic safety precautions may result in serious personal injury.

Introduction

Thank you for choosing a Northern Tool + Equipment product, the Cutoff Saw, Item# 999000. For future reference, please complete the owner's record below:

Model: _____ Purchase Date: _____

Save the receipt, warranty and this Owner's Manual. It is important that you read the entire manual to become familiar with this product before using it.

This Manual contains operating and safety instructions for your cutoff saw. For maximum performance and satisfaction from your cutoff saw, it is important that you read and understand the maintenance and safety manual before operating the saw. Northern Tool + Equipment strongly recommends that this machine not be modified and/or used for any application other than that for which it was designed. If you have any questions or do not understand any of the instructions in this Manual, please call 1-800-222-5381.

Because the cutoff saw operates at high speeds, special safety precautions must be observed before operating the saw. Careless or improper use could cause serious or even fatal injury.

The engine for the cutoff saw has been approved and certified by U.S. EPA

Table of Contents

Main parts and their functions	3-5
Safety precautions	5-8
Specifications	9
Operation guide to the cutoff saw	10-13
1. Before starting	10-11
2. Starting	11-12
3. Operation	12
4. Emergency Stopping	12
5. Notes on operation	12-13
Adjustment of cutoff saw	13
1. Adjusting V-belt tension	13
2. Adjusting carburetor	13
3. Adjusting blade guard	13
Maintenance & repair of cutoff saw	13-15
1. Cleaning and maintenance of air filter	13-14
2. Maintenance of spark plug	14
3. Replacing starter rope	14-15
4. Replacing pawl	15
5. Maintenance chart	16
Storing cutoff saw	17
Exploded parts views and parts lists	18-25
1. Crankshaft Housing Assembly	18
2. Crankshaft & Piston Assembly	19
3. Cylinder & Muffler Assembly	20
4. Oil Tank & Carburetor	21
5. Handle & Main Cover Assembly	22
6. Air Filter Assembly	23
7. Cutter Assembly	24
8. Transmission Box & Assembly	25

Main parts of the cutoff saw and their functions

This product is composed of two main sections: a gasoline-powered 2-stroke engine and a driving/cutting system. When engine speed is up to 3800 RPM, the cutting blade, driven by the engine via a belt transmission system, begins to rotate at a high speed and is ready for cutting work.

Shown below are the main parts of the cut-off saw and their corresponding function descriptions (Ref. Fig. 1):

1. Blade
2. Flanges
3. Hexagon Bolt
4. Blade Guard
5. Front Handle
6. Spark Plug Cover
7. Kill Switch
8. Full Throttle Lock Button
9. Throttle Trigger
10. Rear Handle
11. Filter Cover Lock Lever
12. Air Filter
13. Choke Lever
14. Starter Grip
15. Fuel Tank Cap
16. Decompression Valve
17. Water Attachment
18. Tensioning Nut
19. Muffler
20. Adjusting Lever of Blade Guard

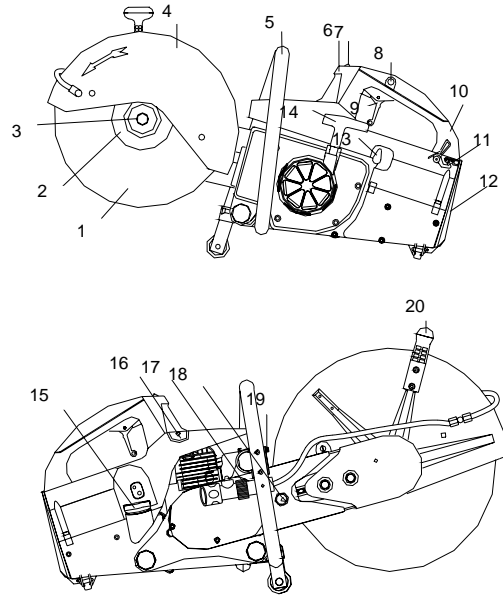

Fig. 1

1. Blade

Diamond or abrasive blades. Depending on the material to be cut, these blades are made of different materials. Be sure to choose right blade for the material being cut. The maximum diameter of the blade for the saw is 14". The operating speed of the blade should be above or equal to 5300 RPM.

2. Flanges

Clamp and support the diamond or abrasive blade.

3. Hexagon Bolt

Tightens blade flange.

4. Blade Guard

Safety guard directs sparks and dust away from operator.

5. Front Handle

Used to securely hold the saw while under operation.

6. Spark Plug Cover

A removable cover for access to the spark plug.

7. Kill Switch

Engine stops when this switch is pressed and held.

8. Full Throttle Lock Button

Locks the throttle in full open position by pressing this button while the trigger is fully depressed. Pressing and releasing the trigger returns the throttle to idle position.

9. Throttle Trigger

Controls engine speed by manipulating the throttle. Pulling the trigger backward opens the throttle and the engine accelerates. Releasing the trigger slows down the engine.

10. Rear Handle

Used to securely hold the saw while under operation.

11. Filter Cover Lock lever

Locks the air filter cover. Pull back on the lever to open the filter cover.

12. Air Filter

Filters dirt and debris from entering carburetor.

13. Choke Lever

Turning this lever counter clockwise closes the carburetor. Used to prime engine (cold starting). Turn clockwise for normal operation.

14. Starter Grip

Pull to start engine.

15. Fuel Tank Cap

Open this cap for filling the fuel. Close the tank for starting and operation.

16. Decompression Valve

Press down on this valve to make starting easier. When air pressure in the engine reaches a preset value, it automatically closes.

17. Water Attachment

Feeds water to both sides of diamond blade. Connect to water supply for wet cutting.

18. Tensioning Nut

For V-belt tension adjustment. Turn this nut clockwise to loosen the V-belt, turn the nut counterclockwise to tension the V-belt.

19. Muffler

Reduces both noise and emissions.

20. Blade Guard Adjusting Lever

Allows adjustment of blade guard to direct dust away from operator.



SAFETY PRECAUTIONS:



As the cutoff saw is a high speed power tool, improper use of this saw might be hazardous. To avoid property damage or personal injury, it is **EXTREMELY IMPORTANT** to read, fully understand and observe the following safety precautions before operating this cutoff saw.

1. Worksite Requirements:



The worksite should be free of any materials or objects that are flammable or explosive.

Surroundings should be in order, without clutter, have sufficient visibility and be well ventilated. The flooring the operator stands on should be nonskid. Take extreme care when working in wet and freezing weather (rain, snow, frost, ice).

Bystanders should keep away from the saw when it is operating. Children, the handicapped and animals should never be allowed in the work area.

Loose objects may be thrown toward the operator by the cutting tool; position the object to be cut securely to ensure it can't be moved by the blade when cutting.

2. Blade:



Before installing a blade, make sure that the maximum operating speed of the blade is above or equal to the spindle speed of your cutoff saw. Inspect the cutting blade frequently and replace immediately if the cutting blade is cracked or warped.

Cracked or warped blades may shatter or break and cause serious personal injury.

Failure to follow these directions may cause the blade to shatter or crack in use, causing serious or fatal injury.

Never use carbide-tipped, woodcutting or circular machine blades. They can cause severe personal injury from reactive forces, blade contact or thrown objects.

Use of the wrong cutting blade for which it was not designed may cause that blade to shatter, causing serious or fatal injury. Only use the cutting blade approved for the type of material to be cut.

Diamond blades have a much better cutting performance than standard abrasive blades. The blades are steel centered and diamond particles are imbedded in their cutting edges.

Wet or dry cutting is possible. Cutting wet will extend the life of your diamond blades. A water attachment comes as standard equipment with this cutoff saw. Before using the water attachment, make sure that the screw that secures the outlet tube is tightened.

Always install the blade so that the arrow on the blade points in direction of the rotation of the spindle.

Before carrying or transporting your cutoff saw, make sure the engine is OFF. Never leave the engine running while unattended (e.g. on the ground).

Proper tension of the V-belt is important. In order to avoid a false setting, the tensioning procedure must be followed as described in your manual. Always make sure the hexagonal collar nuts for the cast arm are tightened securely. Check V-belt tension after one hour of operation and correct if necessary.

3. Operator:

The cutoff saw is a one-person tool. Start and operate this saw without assistance.

Make sure you are in good physical condition and are not under the influence of any substance such as drugs or alcohol which may impair vision or dexterity. Take breaks as needed to prevent you from getting fatigued.

Never let the cutoff saw run unattended. **NO** untrained personal should ever be allowed to use a cutoff machine. Bystanders, especially children and animals, should not be allowed in the area where a cutoff machine is in use.

Do not lend or rent your cutoff machine without this Operation Manual. Employers should establish a training program for operators of this saw to ensure safe operation of this powerful tool.

Avoid loose-fitting jackets, scarves, neckties, jewelry, flared or cuffed pants, unconfined long hair or anything that could become caught or entangled on any moving parts of the unit. Wear overalls or long pants to protect your legs. Do not wear shorts.

Protect your hands with gloves when handling the cutoff saw. Heavy-duty, nonslip gloves improve your grip and protect your hands.

Operate the cutoff saw with both hands, keeping a firm grip on the front and rear handles.

Maintain good balance and footing at all times.

Good footing is most important. Wear sturdy boots with nonskid soles. Steel-toed safety boots are recommended.



To reduce the risk of injury to your eyes, never operate the cutoff saw **unless wearing goggles** or properly fitted safety glasses with adequate top and side protection. ***Proper eye protection is a must!***

Wear an approved safety hard hat to protect your head. Cutoff machine noise could damage your hearing: Wear earplugs or ear protectors at all times.



Cutting masonry, concrete, metal and other materials can generate dust, mists and fumes containing chemicals known to cause serious or fatal injury or illness, such as respiratory disease, cancer, birth defects or other reproductive harm.

Cutting masonry, concrete and other materials with silica in their composition may give off dust containing crystalline silica. Silica is a basic component of sand, quartz, brick clay, granite and numerous other minerals and rocks. Use of an approved respirator is recommended.

Do not cut materials containing asbestos, as asbestos dust can cause severe physical injury. Do not cut materials containing highly volatile or flammable substances.

4. Inspection of the cutoff saw before use:

1. Make sure there are no loose objects on or near the saw.
2. Except for the carburetor adjustment screws, all other bolts, nuts, screws and the fuel tank cap should be securely tightened. Make sure all rubber hoses for oil flow are tightly connected with no leaks.
3. Make sure the blade rotates smoothly; the starter rope can be pulled through and guided back without being tangled.
4. Check to make sure the Throttle Trigger, the Full Throttle Lock Button, the Choke Lever, the Decompression Valve and the Kill Switch all function well without failure.
5. Check to make sure the blade guard has no visual damage. Adjust the guard as necessary so the spark beam generated during cutting can be directed away from the operator (Ref. Fig. 2).
6. Check to make sure the V-belt is properly tensioned.
7. Make sure the saw is free of oil spillage.
8. Make sure the main cover and the handles are dry and clean.
9. Do not attempt to start the saw if damage is found or if it's not completely and securely assembled and properly adjusted.

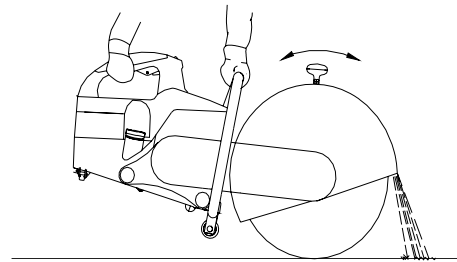

Fig. 2

5. Precautions on starting:

1. Keep a good balance and secure footing.
2. Take hold of the starter grip firmly; do not wrap the rope around your hand.
3. To start, place the machine firmly against the ground and make sure the blade is not in contact with the ground or the object to be cut.
4. Pull sharply on the rope and guide it back slowly. Do not let go of the grip halfway through the pull to prevent it from snapping back.

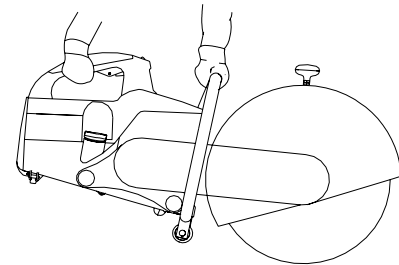

Fig. 3

6. Precautions on operation:

1. Keep a good balance and secure footing while holding the saw firmly at all times. (Ref. Fig. 3)
2. Press the throttle trigger backward slowly to make the engine accelerate gradually. Wait until the blade builds up the RPMs before beginning to work.
3. Move the rotating blade slowly toward the object to be cut, increase the pressure gradually after the cutting edge comes in contact with the object. Make sure the cutting depth is appropriate.
4. Do not change direction of the cut or twist during the cut as this may produce a high

torsion load on the blade and may cause it to break or shatter. Only move the machine along a straight line, forward or “to and fro” in the cutting direction.

5. When cutting, position the saw at an appropriate distance so that your body is clear of the blade attachment yet you don't have to overreach.

6. Release the pressure on the saw when the blade completes a cut. The cutoff portion of the object may drop, so make sure it won't hit any part of your body or pinch the blade.

7. Whenever you hear an abnormal sound coming out of the cutoff saw, stop cutting immediately for inspection (Note the muffler and the blade are very hot at this time, so take care not to get burned). Only resume work after the trouble is eliminated.

8. Do not make adjustments or perform any maintenance or troubleshooting with the cutoff saw while it is running.

9. Take precaution when re-entering a cut and do not turn the blade at an angle or push it into the cut, as this may cause the blade to become pinched.

7. Precautions on fueling:

1. Fuel the machine only in a well-ventilated environment.

2. Before refueling, let the engine cool off naturally. Do not take any other forceful measures to cool the engine down.

3. Remove the fuel tank cap slowly and carefully to allow any pressure build-up in the tank to be released (Ref. Fig. 4).

4. Tighten fuel cap securely after fueling and clean off spillage, if any.

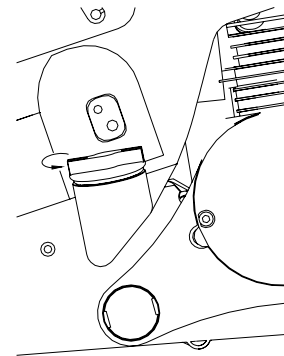

Fig. 4

8. Notes on transporting:

1. Always stop the engine before relocating the saw.

2. When carrying the machine with a hot engine, take care not to have any part of your body come in contact with the muffler; burns could occur.

3. Prevent the saw from touching the ground or any hard objects.

9. Notes on maintenance:

Perform any maintenance or repair work in clean and neat environment. Use proper tools and operate with caution.

Do not attempt to modify your cutoff saw in any way. Use only identical spare parts for replacement.

The cutoff saw is only intended for cutting work and cannot be used for prying or shoveling away any objects, or used as a grinding tool with the sides of the blade.

Specifications:

Engine	Model	1E49F (Engine Family 3ZHIS.0642CR)		
	Type	Single-cylinder, two-stroke, air-cooled		
	Cylinder bore	1.96"		
	Piston stroke	1.36"		
	Displacement	64.1 cc		
	Max. output	3.8 HP		
	Speed at max. output	8500 RPM		
	Max. torque	3.5N.m		
	Idle speed	2400 RPM		
	Lock-up speed of clutch	3800 RPM		
	Min. fuel consumption	544 g/(kw.h)		
	Fuel mix	Gasoline	Minimum octane rating 93	
		Oil	Two stroke engine oil	
		Mix ratio	75:1	
Fuel tank capacity	0.4 gallons (1.5L)			
Engine	Ignition type	Electronically controlled (breakerless) magneto ignition		
	Electrode gap of spark plug	0.02"		
	Spark plug thread	M14 x 1.25; 0.38" long		
	Starting method	Recoil start		
	Rotation direction	Clockwise		
Blade	Diameter	Maximum 14"		
	Max. operating speed	5300 RPM		
	Thickness	0.1"-0.24"		
	Arbor hole diameter	1"		
	Types	Composite abrasive blade or diamond abrasive blade		
	Cutting depth (with thrust plate dia. 4 1/2")	Max. 4 1/2"		
	Sound level	110dB		
	Overall dimensions	(29.5" x 14" x 12")		

Operation Guide to Cutoff Saw

1. Before starting:

Preparation includes clearing and arranging work surroundings, wearing proper clothing and protection, and inspecting the cutoff saw. In preparation, please follow the procedures described in the appropriate section of this manual. For additional preparation work before starting, please follow instructions given below:

Fueling:

- a) Before starting, check if there is any fuel left in the fuel tank.
- b) This engine is engineered to operate on mixture of unleaded gasoline and quality two-stroke engine oil. Octane rating of the gasoline should at least be 93.
- c) Gas-to-oil mix ratio is 75:1.
- d) When mixing fuel, pour engine oil into the canister first, and then add gasoline (make sure the mix ratio is 75:1). Shake the mixture in the canister thoroughly.
- e) Clean the fuel tank cap and the area around it as necessary to ensure no dirt falls into the tank. Finally pour the fuel mixture into the tank and tighten fuel tank cap securely.
- f) Only mix sufficient fuel for a few days work, the maximum storage time of mixed fuel is 3 months.

Choosing the right blade:

- a) Blade diameter can be 12" or 14". Choose an appropriate size and type of blade which best suits the cutting work. Keep in mind the blade size needs to be fitted with the blade guard. The diameter of the arbor hole for the blade should be 1". Blade thickness should be within the range of .100"–.240".

b) Blade types:

For your reference, choose composite abrasive blades for cutting of asphalt, concrete, stone, brick, steel and plastics. Choose diamond abrasive blades for cutting of asphalt, concrete, stone, hard rock, brick, etc.

Note: There is a rotation direction indicator marked on each diamond blade. When mounting, make sure it corresponds to the rotation direction of the arbor. If you are not sure which blades are proper for your cutting jobs, contact your dealer or distributor for information.

c) Fitting/Replacing the blade: (Ref. Fig.5)

Slide the locking pin (1) through the bore in the V-belt guard (2) (turn the blade until the locking pin engages in one of the bores on the belt pulley (3)). Use the combination wrench to loosen and unscrew the hexagon bolt (4). Remove the metal washer (5), the flange (6) from the arbor together with the blade to be replaced.

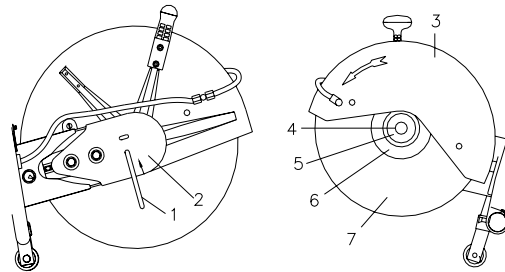

Fig. 5

Mount the new blade (7).

Fit the flange and metal washer.

Screw in the hexagon bolt and tighten it with the combination wrench.

Finally draw the locking pin out of the V-belt guard.

Tensioning the V-belt: (Ref. Fig.6):

Loosen and unscrew the two hexagon bolts (2) on the V-belt guard (1) and then remove the V-belt guard.

Loosen the three hexagon bolts (4) on the bearing plate (3).

Turn the tensioning nut (5) clockwise until the V-belt is tensioned.

Tighten the three hexagon bolts on the bearing plate.

Fit the V-belt guard and fit and tighten the two hexagon bolts (2).

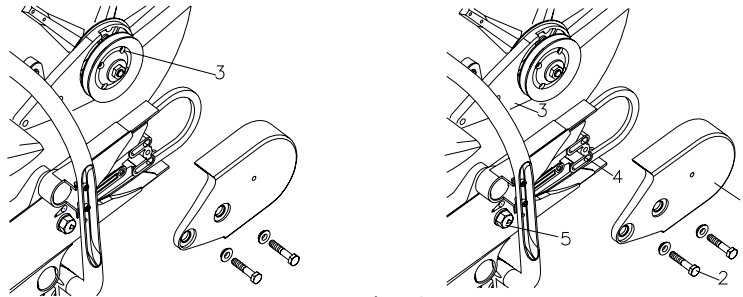

Fig. 6

2. Starting (Ref. Fig.7):

Place the cutoff saw on the ground and make sure it's well balanced; see to it that the saw blade does not touch any objects or the ground and that there is no person within the swivel range of the saw.

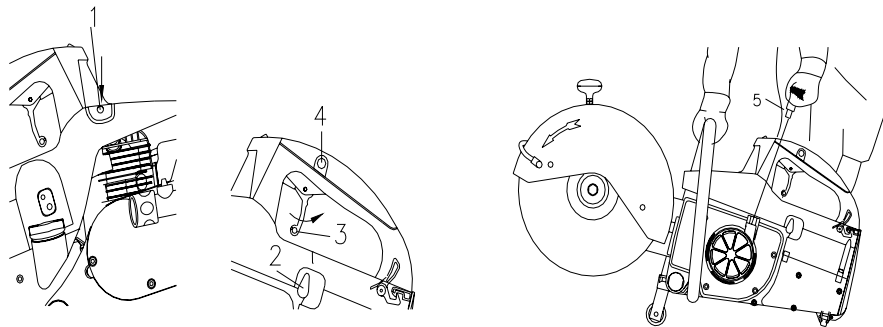





Fig. 7

Press the button of the decompression valve (1).

Set the choke lever (2) to an appropriate position:

to  if the engine is cold;

to  if the engine is warm (even if the engine has already run but is still cold);

to  if the engine is warm (latched position for warm start).

Pull the throttle trigger (3) backward as far as the stop and hold it in position.

Press down the full throttle lock button (4).

Release the throttle trigger (3).

Hold the front handle with left hand and firmly press the cutoff saw against ground, place the right foot on the carburetor box cover.

Holding the starter grip (5) securely, slowly pull out the starter rope for a short distance, and then pull it through quickly and strongly.

Note: Starter rope is 3 3/4-ft. long; do not pull the rope out more than its length otherwise it may break or cause damage to the starting system.

- Do not let go of the starter grip.
- After pulling, guide the rope back into place slowly.
- Pull the rope only straight up and down through the rope guide bushing to prevent it from wearing.

After the rope has been pulled through:

- If the engine does not start, press the button of the decompression valve again and restart the engine.
- If the engine runs for a while but doesn't keep running, press the decompression valve in, move the choke lever to \curvearrowright and then restart the engine.

As soon as the engine is running, briefly blip the throttle trigger (3) at once. The full throttle lock button (4) reverts to its original position and the engine idles.

If the engine is new, or has been stored for a long period of time, pull the starter rope through several times to ensure that sufficient fuel is delivered into the fuel line and combustion chamber of the engine.

3. Operation:

The blade will not run when the engine idles.

When the cutoff saw is ready for actual cutting work, gently pull the throttle trigger (3) backward to accelerate the engine, when the speed is over 3800 RPM, the blade begins to rotate and speeds up. When the blade speed is up and stable, you can begin to move the saw slowly toward the object to be cut. After the cutting edge comes in contact with the object, increase pressure to the saw slowly until the blade is at the desired depth. Finally hold the machine securely and move along a straight line to complete the cut.

To stop or halt the cut (when a cut is completed, or the engine runs out of fuel halfway, or abnormal sound is heard), first lift the blade out of the cut, then release the throttle trigger, wait until the engine slows down to idle speed and the blade stops running, then finally turn off the machine.

4. Emergency stopping (Ref. Fig.8):

Under normal conditions, the machine is to be turned off when the engine idles. However, if a malfunction or emergency occurs during cutting, you can stop the engine immediately by pressing and holding the Kill Switch (2) on the front end of the rear handle (1). But note that the service life of some components of the saw may be adversely affected if the engine is stopped too often during cutting.

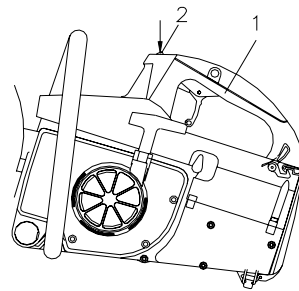

Fig. 8

5. Notes on operation

Follow all applicable instructions in this manual when operating the cutoff saw.

During the break-in phase, which takes about 8 hours, the saw must not be operated at high speeds without load (do not pull the throttle trigger beyond 3/4 of full throttle). Following this procedure will lengthen the service life of your machine.

After the saw works for a certain period of time, let the engine idle on for a while to dissipate the heat. This will prevent some engine parts (ignition system, carburetor, etc.) from being damaged by over heating.

ADJUSTMENT OF CUTOFF SAW

1. Adjusting V-belt tension:

Refer to the instruction described above in the section titled “Tensioning the V-belt.”

2. Adjusting carburetor:

The carburetor has been preset and adjusted at the factory to reach the optimum fuel-air mixture for a smooth, fuel efficient, reliable running engine with low emissions. The air filter and the spark plug need to be checked and maintained regularly. However, if the cutoff saw is found to be unsatisfactory in operation (such as the idle speed either too high or too low, or abnormal exhaust emission still persist), a slight adjustment on the carburetor might be necessary, which includes (Ref. Fig. 9):

Standard setting adjustment:

Find the Low Speed Adjusting Screw “L” (see Fig.9, inside the upper hole of the carburetor seal cover), use a screw driver to turn the screw L clockwise all the way to its end. Then turn the screw L backwards (counterclockwise) 360°.

Adjusting idling speed:

It is usually necessary to adjust the idle speed after Standard setting adjustment (above). To adjust idle speed, start the engine first.

If the idle speed is too low, the engine may shut off after starting. In this case, make the standard setting first as instructed [above], then turn the idle speed adjusting screw LA (see Fig. 9) inside the lower hole of carburetor seal cover clockwise until the blade starts to run. Then turn the screw LA backwards (counterclockwise)

1/4 circle (90°).

If the idling speed is too high, the blade will run at idling speed, which is not good for the cutoff saw. In this case, make standard setting adjustment first, then turn the idling speed adjusting screw LA counterclockwise until the blade stops running. Then turn the screw LA 90° further (counterclockwise).

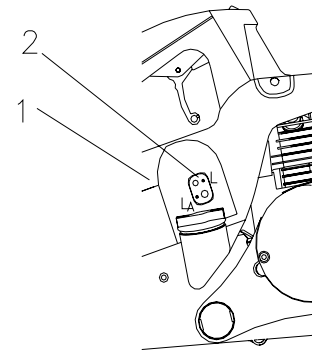

Fig. 9

3. Adjusting blade guard (Ref. Fig.10):

The blade guard deflects sparks from the operator. Move the adjusting lever (2) to change the position of the blade guard.

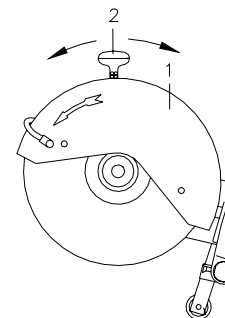

Fig. 10

MAINTENANCE & REPAIR OF THE CUTOFF SAW

1. Cleaning and maintenance of the air filter

Dust and foreign build-up accumulated on the air filter may affect engine performance, increase fuel consumption and cause difficulty in starting; therefore, it is important to perform regular maintenance. The frequency of this depends on the conditions of the cutting jobs as well as material being cut both wet or dry. For dry cutting, maintenance is required every 48 hours. For instructions, see Fig. 11.

1. Set the choke lever to \circ .
2. Pull the filter cover lock lever (7) backward to let the filter cover (1) swing open. Then take out in succession pre-filter (2), pre-filter (3), filter housing (4), paper air filter (5), and the secondary filter (6). Then clean and dry all these parts. Replace if any are damaged. Finally replace all of them in succession and close the filter cover.

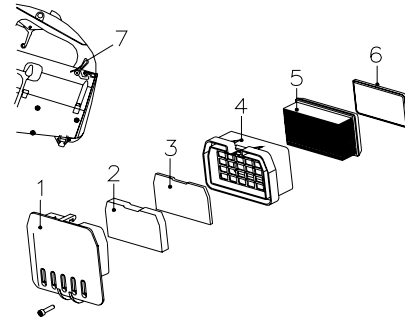

Fig. 11

2. Maintenance of spark plug (Ref. Fig. 12):

Wrong fuel mixture (too much engine oil in the gasoline), low quality gasoline or oil, dirty air filter, clogged spark arrestor screen, and other unfavorable running conditions are factors affecting the condition of the spark plug as they cause carbon

deposit accumulation, which results in trouble in engine operation. Therefore, if the engine is down on power, difficult to start or runs poorly at idling speed, first check the spark plug.

1. Remove the spark plug cover (2) on the front end of the main cover (1).
2. Remove the plug boot (3) and the spark plug (4) in succession.
3. Clean off the carbon build-up on the spark plug.
4. Check electrode gap A to see if it is 0.020": readjust if necessary.
5. Replace spark plug after approx. 100 operating hours, or earlier if the electrodes are badly eroded. (A BPMR7R-type spark plug is recommended for replacement.)
6. Refit the plug boot and make sure it is snugly connected to the spark plug.

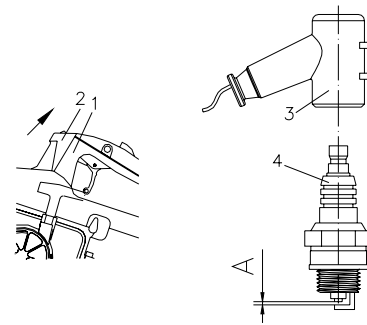

Fig. 12

3. Replacing starter rope (Ref. Fig. 13):

The starter rope may need to be replaced when frayed or broken.

1. Unscrew the screws (2) on the flywheel/starter cover (1) and remove the cover from the engine unit.
2. Remove the spring clip (8), remove the rope rotor (7) with pawl (9).
3. Using a screwdriver, unscrew the screw plug (3) on top of the starter grip, remove the starter rope (4) out of the grip.
4. Put a new rope down through the grip and the rope guide bushing (5), make a simple knot at the end of the rope and screw in the screw plug (3)
5. Thread the rope through the rope rotor (7) (enter from the hole on the rotor groove) and secure it with a simple knot.
6. Wind the rope around the rope rotor (7) clockwise until there is a length of about 12" left unwound.
7. Slip the rope rotor onto the starter post (6) and turn it back and forth a little until the anchor loop of the rewind spring engages.
8. Replace the pawl (9) in the rope rotor.
9. Press the spring clip (8) onto the starter post and over the peg of the pawl with a screwdriver.

Note: The spring clip must point counterclockwise.

10. To tension the rewind spring, first guide the rope through the notch on the edge of the rope rotor and form a loop, use it to turn the rope rotor 4–5 times counterclockwise.
11. Then hold the rope rotor tight, pull out the twisted rope and untangle it.
12. Release the rope rotor, slowly let go of the starter rope so that it is wound up on the rope rotor.
13. Refit the flywheel/starter cover (1) and screw in the four screws (2).

4. Replacing pawl (Ref. Fig. 13):

The pawl functions as a link between the rope rotor and the crankshaft (by engaging and disengaging the starter cup) and needs to be replaced if damaged.

1. Unscrew the screws (2) on the flywheel/starter cover (1) and remove the cover from the engine unit.
2. Remove the spring clip (8), then remove the damaged pawl (9).
3. Install a new pawl.
4. Refit the spring clip (8) and the flywheel/starter cover (1) in succession.

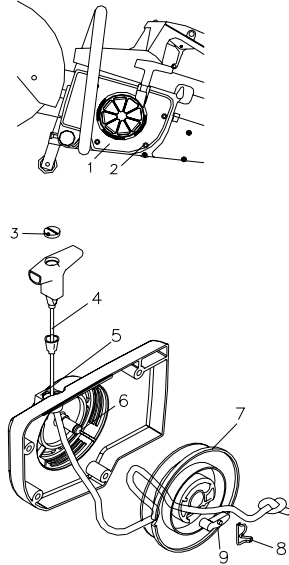

Fig. 13

5. Maintenance chart

The following information refers to normal operating conditions. The specified intervals must be reduced accordingly when working under aggravated conditions (severe dust formation, for example) and with longer daily working hours.

		Before starting work	After work or daily	Every time after refueling	Weekly	Monthly	In the event of a malfunction	If damaged	As required
Complete Machine	Visual inspection	√		√					
	Clean		√						
Throttle trigger, Kill Switch	Functional test	√		√					
Filter in fuel tank	Check					√			
	Replace						√		
Fuel tank	Clean					√			
V-belt	Clean					√			
	Replace							√	√
Air filter (all filter components)	Clean	√					√		√
	Replace							√	√
Cylinder fins	Clean		√						
Spark arresting screen in the muffler	Inspect		√						
	Clean or replace								√
Carburetor	Check idle speed (the cutting wheel must not run)	√		√					
	Adjust idle speed								√
Spark plug	Adjust electrode gap						√		√
Nuts and bolts (but not adjusting screws)	Retighten	√	√						√
Rubber buffer	Replace						√		
Blade	Check and clean	√		√					√
	Replace							√	√
Support/Bracket	Clean		√						

Storing Cutoff Saw

For long periods of storage:

1. Drain and clean the fuel tank, run engine until carburetor is dry.
2. Thoroughly clean the cutoff saw; tighten all nuts and bolts (except for adjusting screws).
3. Remove the blade and loosen the V-belt.

Notes on transport and storage:

1. Avoid knocks and bumps.
2. Abrasive blades must not be exposed to direct sunlight or other sources of heat during transport and storage.

Store the machine in a place free of moisture and heat source, preferably in a place with consistent temperature. Do not store it near corrosive liquids.

3. Composite blade must be protected against frost.

The remainder of this manual provides detailed exploded parts views and parts lists for the cutoff saw.

1. Crankshaft Housing Assembly

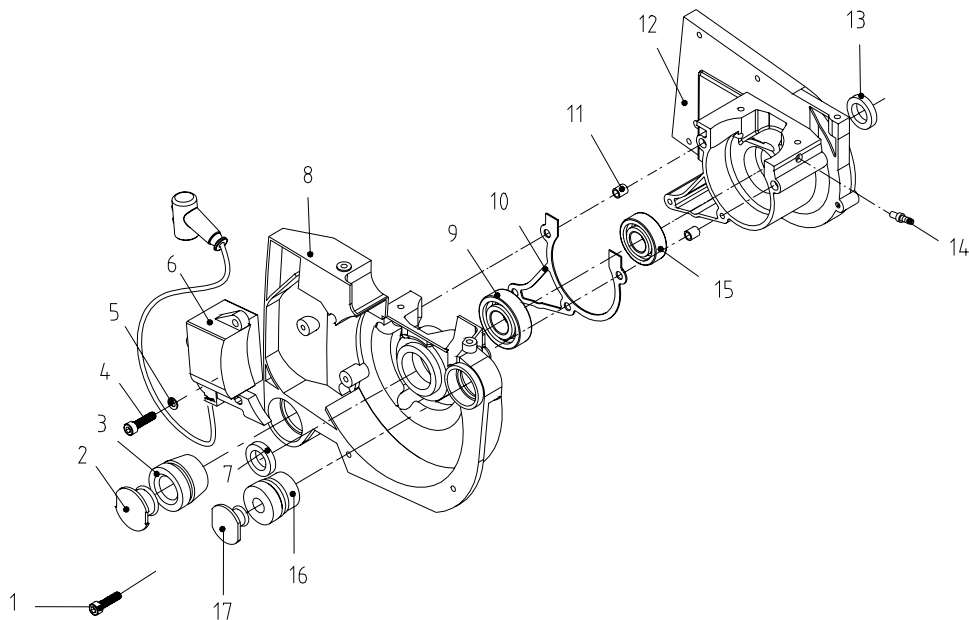

Item	Ref	Description	Qty
1	1E49F01011	Screw M5×20	10
2	1E49F01010	Plug	1
3	1E49F01006	Cover	1
4	1E49F01011	Screw M5×20	3
5	GB97.1	Washer 5	3
6	1E49F05000	Coil	1
7	B1FUD1	Oil seal 17×28×7	1
8	1E49F01001	Crankshaft housing-Left	1
9	GB/T276-94	Ball bearing 6203	1
10	1E49F01003	Gasket	1
11	1E49F01004	Positioning Sleeve	2
12	1E49F01002	Crankshaft housing-Right	1
13	B455	Oil seal 15×24×7	1
14	1E49F01008	Oil needle	1
15	GB/T276-94	Ball bearing 6202	1
16	1E49F01005	Cover	1
17	1E49F01007	Plug	1

2. Crankshaft & Piston Assembly

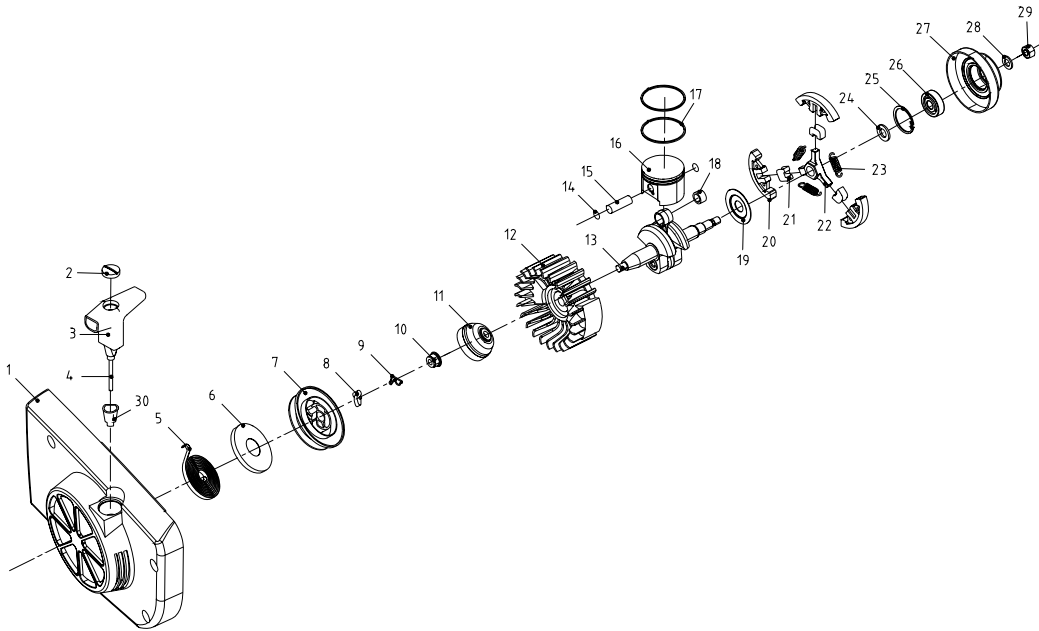

Item	Ref	Description	Qty	Item	Ref	Description	Qty
1	1E49F01009A	Flywheel/Starter	1	16	1E49F02015	Piston	1
2	1E49F03006-	Screw Plug	1	17	1E49F02014	Piston ring	2
3	1E49F03006	Starter grip	1	18	GB/T5801-	Needle cage	1
4	1E49F03006-	Starter rope	1	19	1E49F02006	Washer	1
5	1E49F03011	Rewind Spring	1	20	1E49F02007-	Clutch shoe	3
6	1E49F03005	Spring Cover	1	21	1E49F02007-	Retainer	3
7	1E49F03004A	Rope rotor	1	22	1E49F02007-	Clutch	1
8	1E49F03009A	Pawl	1	23	1E49F02007-	Tension spring	3
9	1E49F03008	Spring clip	1	24	1E49F02007-	Ring	1
10	1E49F02001	Collar nut	1	25	GB/T893.2-	Retainer ring	1
11	1E49F02010A	Starter cup	1	26	GB/T276-94	Bearing 6200	1
12	1E49F02002A	Flywheel	1	27	1E49F02007-	V-belt pulley	1
13	1E49F02000A	Crankshaft	1	28	1E49F02008	Washer	1
14	1E49F02013	Locking clip	2	29	1E49F02009	Collar nut	1
15	1E49F02012	Piston Pin	1	30	1E49F03007	Rope bushing	1

3. Cylinder & Muffler Assembly

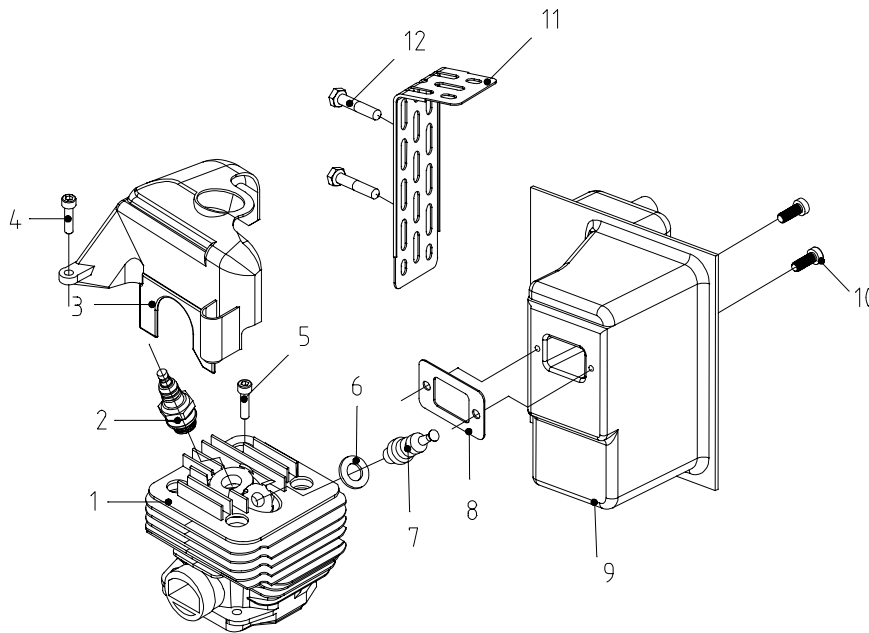

Item	Ref	Description	Qty
1	1E49F04001	Cylinder	1
2	1E49F04003	Spark plug	1
3	1E49F04004	Cylinder cover	1
4	1E49F07016	Screw M5×16	3
5	1E49F01011	Screw M5×20	4
6	1E49F04002-03	Washer	1
7	1E49F04002A	Decompression valve	1
8	1E49F04005	Exhaust gasket	1
9	1E49F08000A	Muffler Assembly	1
10	1E49F07016	Screw M5×16	2
11	1E49F08010	Muffler guard	1
12	1E49F07017	Screw M5×12	2

4. Oil Tank & Carburetor

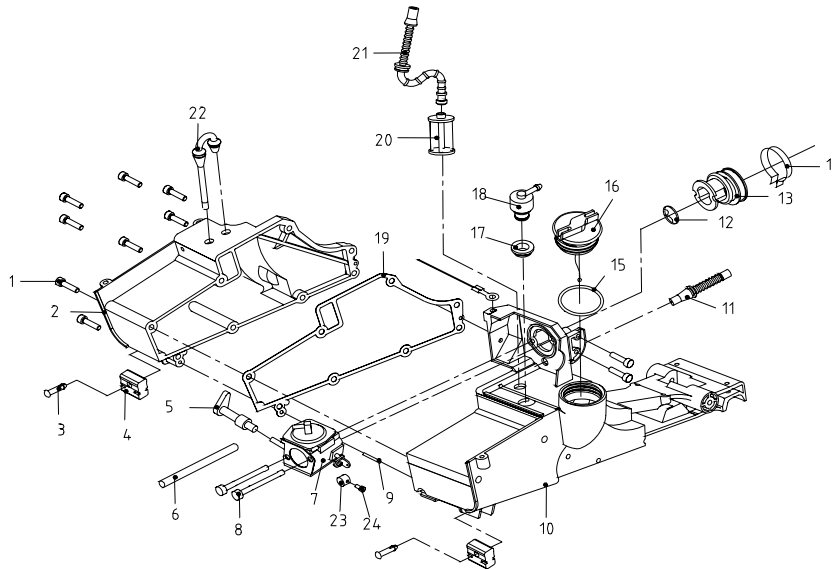

Item	Ref	Description	Qty	Item	Ref	Description	Qty
1	1E49F01011	Screw M5×20	8	13	1E49F06002	Manifold	1
2	1E49FA07002	Oil Tank- Left	1	14	1E49F06005	Hose clip	1
3	1E49F07010	Pin	2	15	1E4907006-01	O-ring	1
4	1E49F07009A	Rubber mount	2	16	1E49F07006	Oil Tank Cap	1
5	1E49FA06005	Choke lever	1	17	1E49F07015	Washer	1
6	1E49F06003	Air hose	1	18	1E49F07014	Tank vent	1
7	1E49F06001	Carburetor	1	19	1E49FA07003	Gasket	1
8	1E49F07020	Screw M5×65	2	20	1E49F07012	Oil Pick-up Filter	1
9	1E49F07011	Split pin	2	21	1E49F07005	Hose	1
10	1E49FA07001	Oil Tank- Right	1	22	1E49F07007	“U”-Rubber tube	1
11	1E49F07004	Connecting Hose	1	23	1E49FA06002	Screw bracket	1
12	1E49F06006	Sleeve	1	24	1E49FA06001	Screw M4×5	1

5. Handle & Main Cover Assembly

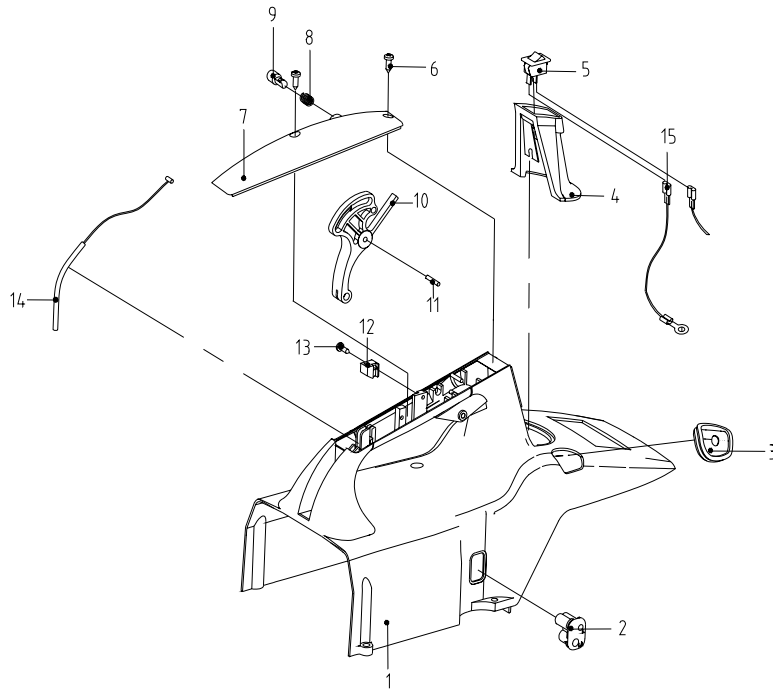

Item	Ref	Description	Qty
1	1E49FA09001	Main Cover	1
2	1E49F09016	Side sealing cover	1
3	1E49F09013	Front sealing cover	1
4	1E49FA09002	Spark plug cover	1
5	1E49FA5001	Kill switch	1
6	GB/T845- 85	Screw ST2.9×13	2
7	1E49FA09010	Handle molding	1
8	1E49F09010-03	Torsion spring	1
9	1E49F09010-02	Full throttle lock button	1
10	1E49FA09003	Throttle trigger	1
11	1E49F09006	Trigger pin	1
12	1E49FA09008	Fixed block	1
13	GB/T845-85	12_1E49F060×13	1
14	1E49FA06002	Throttle triggering wire	1
15	1E49F05004	Flameout Wire	1

6. Air Filter Assembly

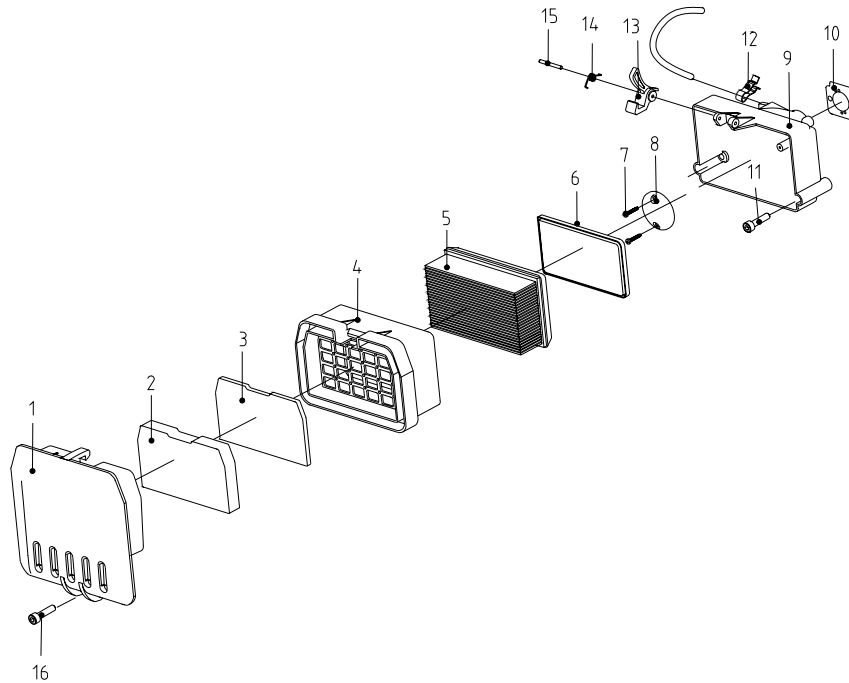

Item	Ref	Description	Qty
1	1E49FA1004	Filter cover	1
2	1E49F1003-02	Pre-filter	1
3	1E49F1003-01	Pre-filter	1
4	1E49FA10001	Filter housing	1
5	1E49F10006	Paper Air Filter	1
6	1E49F10007A	Secondary filter	1
7	GB/T845-85	Screw ST2.9×19	2
8	1E49FA10003	Half round	1
9	1E49FA10002	Filter base	1
10	1E49F06007	Gasket	1
11	1E49F07016	Screw M5×16	2
12	1E49F10010	Flat spring	1
13	1E49FA10005	Filter cover lock level	1
14	1E49FA10006	Torsion spring	1
15	GB119-1986	Pin B3×32	1
16	1E49F07012	Screw M5×12	1

7. Cutter Assembly

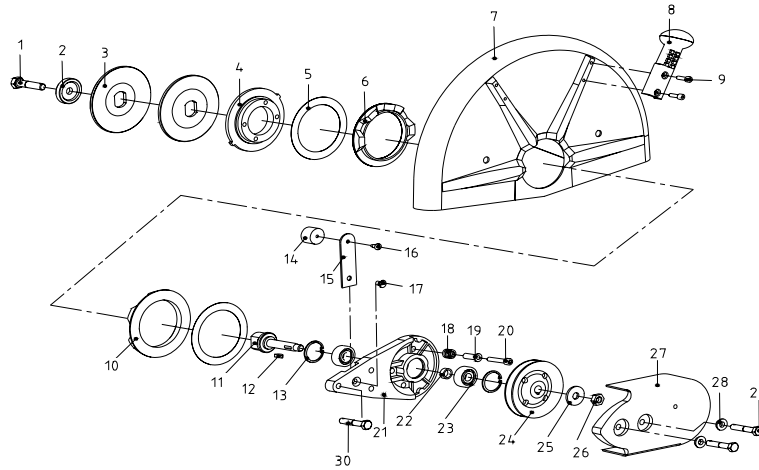

Item	Ref	Description	Qty	Item	Ref	Description	Qty
1	EHS400-01010	Hexagon bolt	1	16	GB/T65-85	Screw M6×6	1
2	EHS400-01011	Washer	1	17	GB68-85	Screw M6×12.5	1
3	EHS400-01013-C	Flange	2	18	EHS400-01019	Tension spring	4
4	EHS400-01014	Blade clamp	1	19	EHS400-01018	Tension bush	4
5	EHS400-01015	Washer	2	20	EHS400-01020	Screw	4
6	EHS400-01016	Inner Rubber ring	1	21	EHS400-01004A	Support	1
7	EHS400-01006A	Blade Guard (400mm)	1	22	EHS400-01021A	Ring	1
8	EHS400-01007A	Handle	1	23	GB/T276-94	Ball bearing 6202	2
9	EHS400-01026	Screw M6×16	2	24	EHS400-01008	Belt Pulley	1
10	EHS400-01017	Outer Rubber ring	1	25	GB1797-85	Washer	1
11	EHS400-01022-D	Shaft	1	26	EHS400-01009	NUT M10×1-Left	1
12	GB/T1099-79	Woodruff key 4×13	1	27	EHS400-01005	Pulley Cover	1
13	GB/T893.2-86	Clip 35	2	28	GB/T96-85	Washer 8	2
14	EHS400-01003-02	Block	1	29	EHS400-01031	Screw M8×22	2
15	EHS400-01003-01	Block arm	1	30	EHS400-01002	Screw	3

8. Transmission Box & Assembly

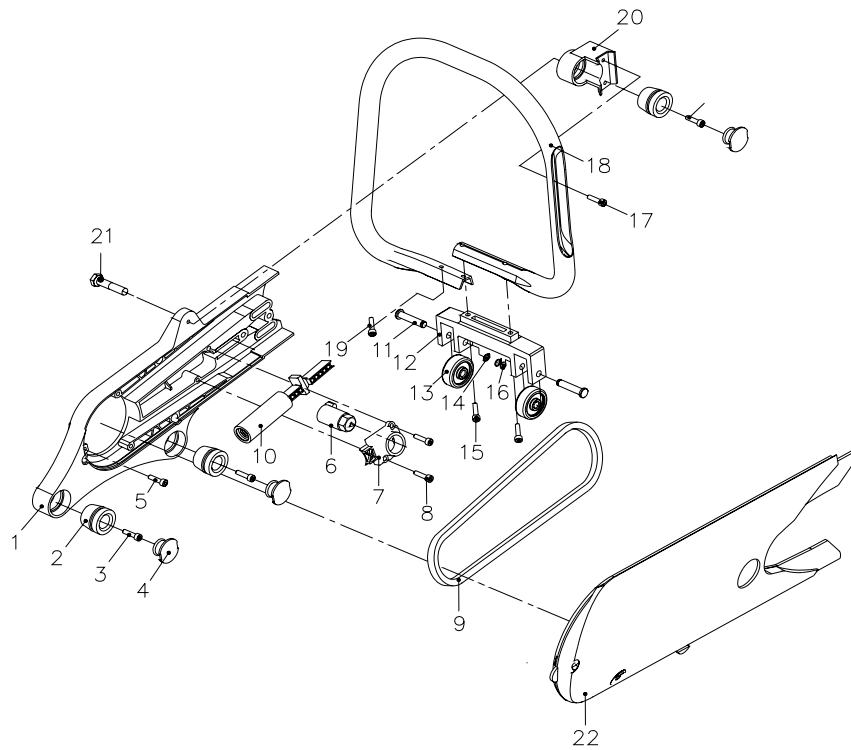

Item	Ref	Description	Qty	Item	Ref	Description	Qty
1	EHS400-02007A	Transmission box	1	12	EHS400-03003-01A	Support	1
2	1E49F01006	Cover	3	13	EHS400-03003-02A	Wheels	2
3	1E49F07019	Screw M6×16	3	14	GB97.2-85	Washer 8	2
4	1E49F01010	Plug	3	15	1E49F07018	screw M5×25	2
5	1E49F01011	Screw M5×20	5	16	GB894.1-86	Spring lock 8	2
6	EHS400-02005A	Clamping lever	1	17	1E49F07021	Screw M5×24	2
7	EHS400-02006A	Cover	1	18	EHS400-03001A	Handle frame	1
8	1E49F07017	Screw M5×12	2	19	1E49F07017	Screw M5×12	2
9	EHS400-02008	V-belt	1	20	EHS400-03002	Handle bracket	1
10	EHS400-02001A	Belt Tensioner	1	21	1E49F07019	Screw M6×16	1
11	EHS400-03003-03	Wheel shaft	2	22	EHS400-02009	Transmission box cover	1

Free Manuals Download Website

<http://myh66.com>

<http://usermanuals.us>

<http://www.somanuals.com>

<http://www.4manuals.cc>

<http://www.manual-lib.com>

<http://www.404manual.com>

<http://www.luxmanual.com>

<http://aubethermostatmanual.com>

Golf course search by state

<http://golfingnear.com>

Email search by domain

<http://emailbydomain.com>

Auto manuals search

<http://auto.somanuals.com>

TV manuals search

<http://tv.somanuals.com>