

Panasonic

Integrated Telephone
Answering System

EASA-PHONE[®]

MODEL NO. **KX-T2470**

Pulse-or-tone dialing capability

OPERATING INSTRUCTIONS

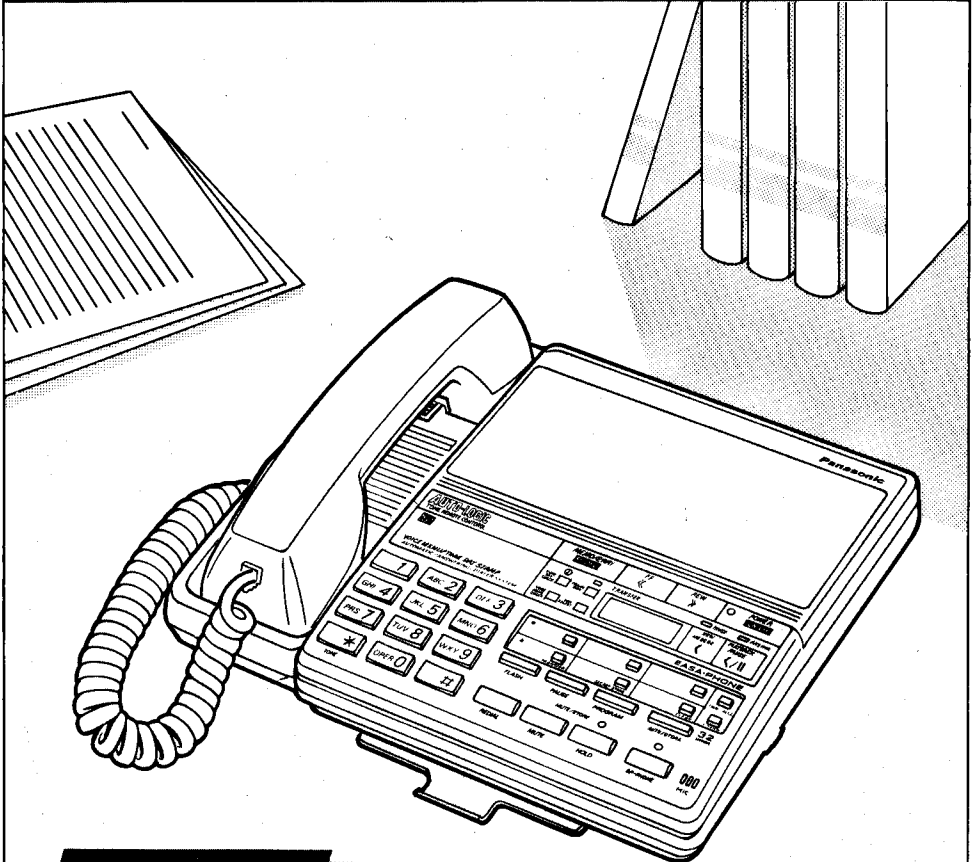

Please read before use.

La referencia rápida en español
puede ser encontrada en las páginas 69~79.
(Spanish Quick Reference can be found
on pages 69~79.)

AUTO-LOGIC™

Features

Thank you for your purchasing the Panasonic telephone answering system.

■ Voice Synthesized Announcements

for the time of day, remote menu, memo check, number of calls, and time/day stamp on each incoming message (ICM).

■ LCD Readout

for the clock, number of messages, OGM 1/2, OGM tape counter, OGM error, and announce modes.

■ New Message Transfer

lets you record a personal introductory transfer message; automatically transfers your incoming messages to a predetermined tone telephone.

■ Two Variable Outgoing Messages (OGMs)

for recording two outgoing messages on a regular audio cassette tape (C-15 tape included). One message is extended; it's limited only by the length of your tape.

■ Tone Remote Control System

lets you activate functions such as Remote Turn On/Off, Transfer On/Off, OGM Switch (1/2), and Answer-Back Speakerphone.

■ New Message Playback

lets you review only those messages which haven't been played before.

■ Built-in Speakerphone

to converse "hands free" or have conference calls.

■ One-Touch/Speed Dialing

with 12 one-touch dialing buttons and 20 speed dialing memory stations.

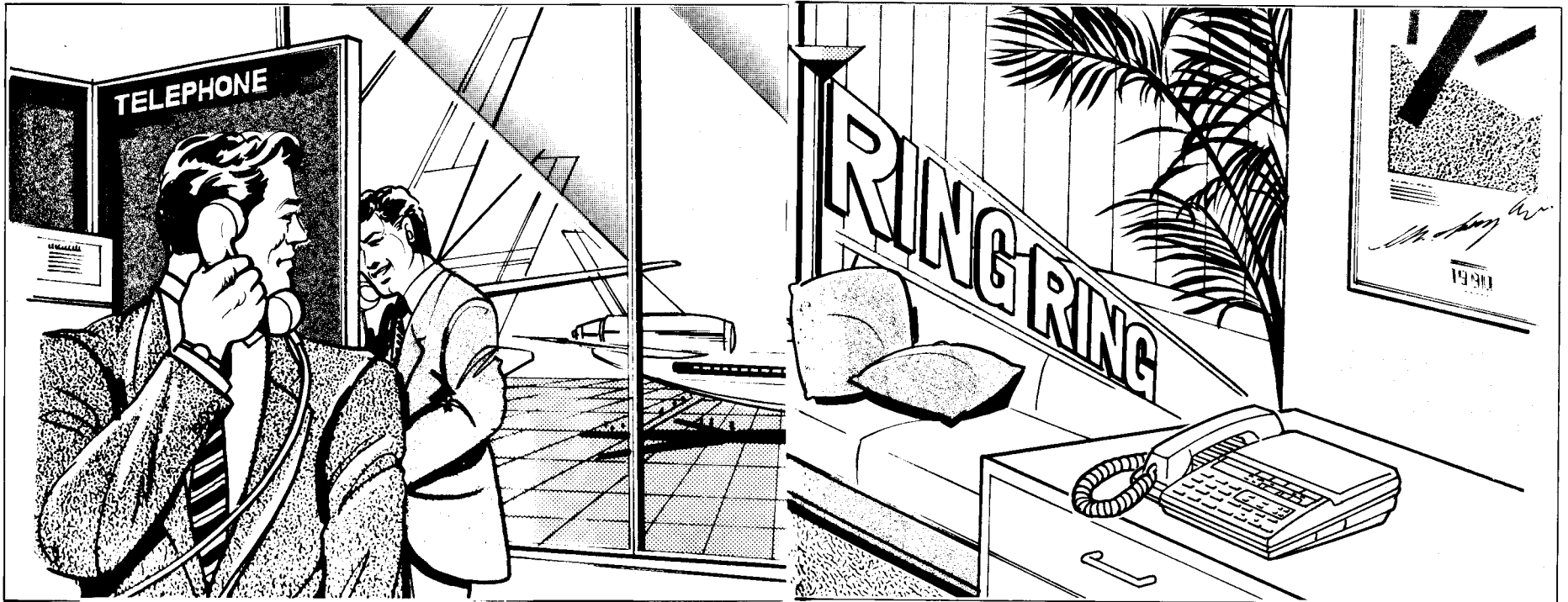

Contents

Features	I~II
Contents	III~VI

Preparation

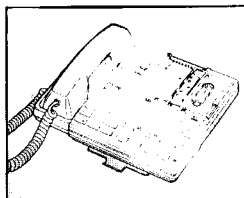

Included Accessories	1
Location of Controls	3~6
Inserting the Tapes	7
Connection	8
Initial Settings	9
Setting the Time and Day	11
Initial Programming	13
Selecting the CPC (Calling Party Control)	13
Selecting the number of rings	15
Selecting the caller's recording time	17
Setting the remote code	19
Recording an Outgoing Message (OGM)	21
Recording an OGM	22
Checking your recorded message (OGM)	23

Telephone

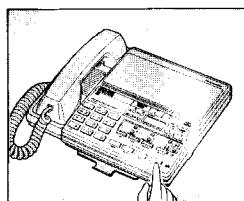

Manual Dialing and Receiving	25
Making calls using the handset	25
Making calls using the SP-PHONE button (on-hook dialing)	25
Answering calls	25
Automatic Dialing	26
Speed dialing	26
One-touch dialing	26
Storing telephone numbers for speed dialing	27
Storing telephone numbers for one-touch dialing	28
Storing telephone numbers with secret features	29
Correcting an error while storing	30
Confirming a stored number	30
Erasing a stored number	31
Voice Memo Check	32
Other Operation	33
Redial	33
Mute, Hold	34
Tone, Flash	35
Pause	36
Combination Dialing	37

Answering Machine



Setting the Answering Machine to Record Incoming Messages	39
Recording from the beginning of the ICM tape	40
Recording after the last recorded message	40
Recording after the messages you want to save	40
Listening to the Recorded Messages	41
Voice time/day stamp	41
Playing back the tape from the beginning	42
Playing back the newly recorded messages	42
Voice Menu	43
Remote synthesized voice instruction	43
Going to the voice menu	43
Direct Remote Operation	46
Playing back newly-recorded messages (Memory Playback)	46
Rewinding/fast forwarding while listening to the messages	46
Resetting the ICM tape for future message	47
Recording your message without listening to the OGM	48
Recording a new OGM (Outgoing Message)	49
Changing OGM mode (1 or 2)	50
Turning on the speakerphone (Answer Back)	51
Setting/canceling the answer mode remotely	52
Transferring the ICM	53
Initial programming for transferring ICM	53
Recording the transfer OGM	53
Checking your transfer OGM	54
Storing the telephone number into the transfer memory station	55
Setting the transfer mode	56
Listening to the transferred ICM	57
Storing a transfer number from a remote phone	58
Setting the transfer mode remotely	58
Other Features	59
Recording a personal messages (Message Memo)	59
Recording a conversation (2-Way Recording)	60
Screening incoming calls	61
Erasing the recorded messages	61

General Information

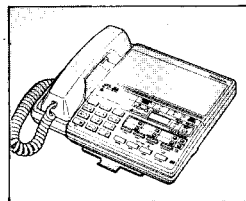

Liquid Crystal Display	63
Announcement by the Unit	64
Troubleshooting Guide	65
Wall Mounting	67
Referencia Rápida (Spanish Quick Reference)	69~79
Accessory Order Information	80
Maintenance	82
Precaution	84
Important Information	85

Included Accessories

AC adaptor one
KX-A11

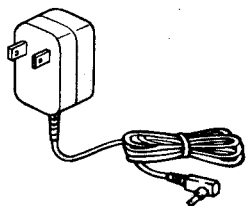

Handset one

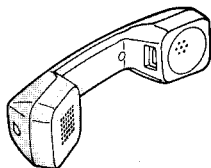

Telephone cord one

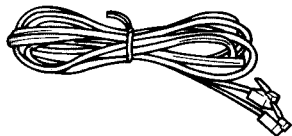

Outgoing Message tape .. one
KX-C150

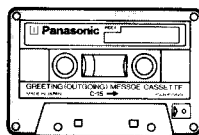

Handset cord one

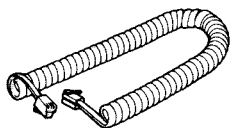

Incoming Message tape .. one
KX-C600



Wall mounting adaptor .. one

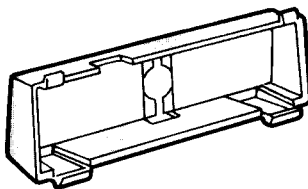

Name card one

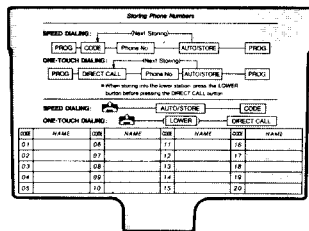

Memory Card

Use a pencil or a ball-point pen to fill in the station directory with station name. (You can use the reverse side for writing, too.)

- Remove the cover using an instrument with a pointed end, like a pen.

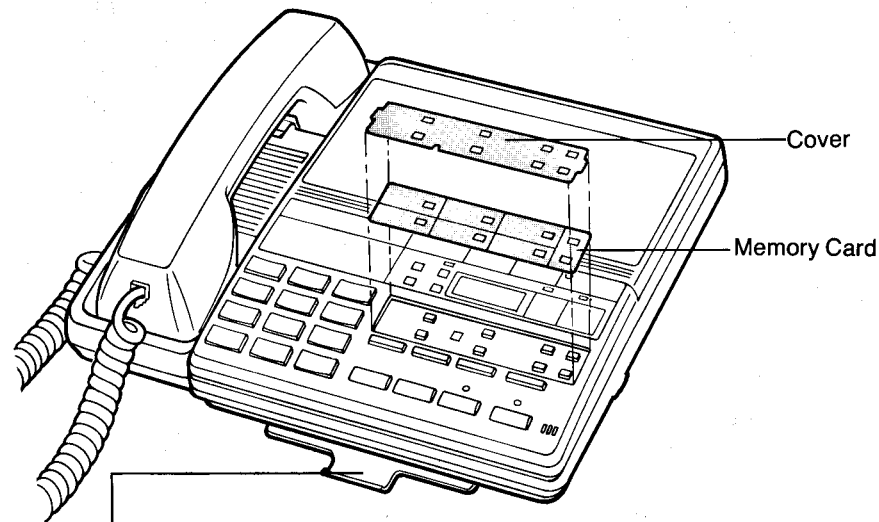
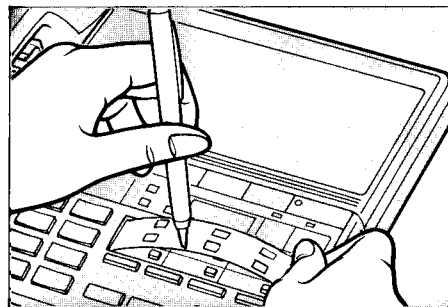

Name Card

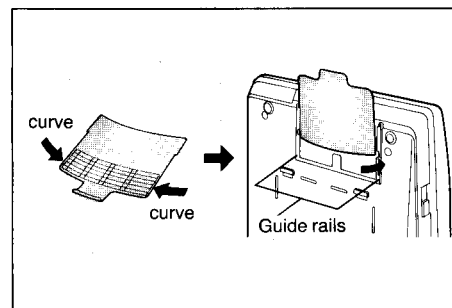

Place the speed dialer name card onto the unit.

- Write station names for speed dialing.

Location of Controls

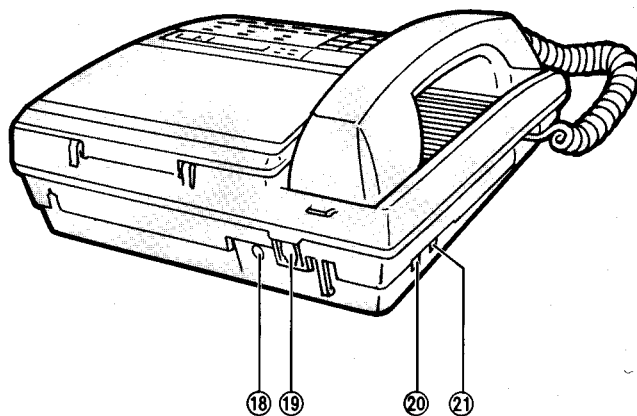
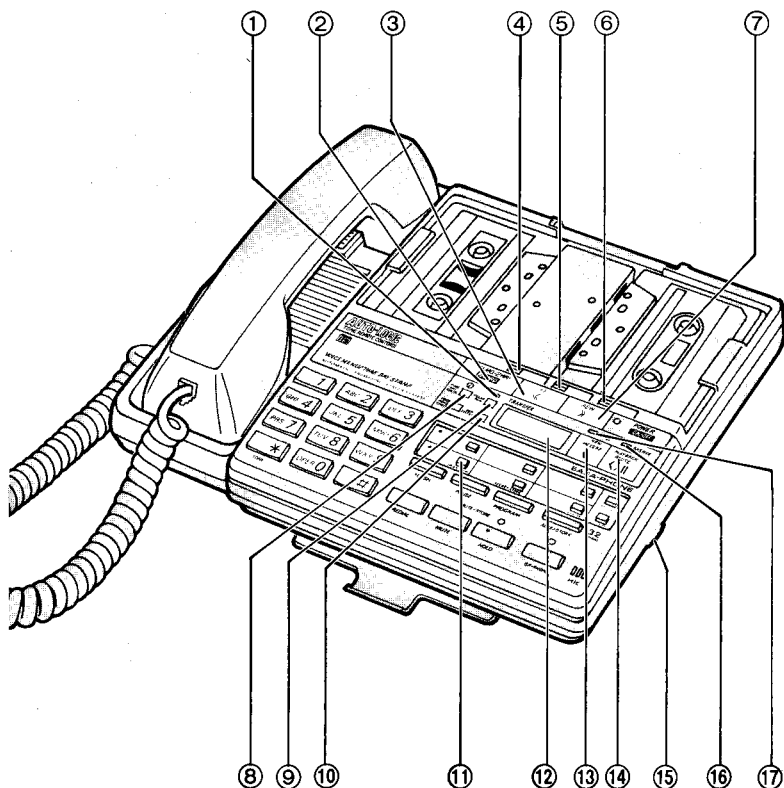

- ① TRANSFER indicator
Lights when the transfer mode is set.
Flashes when the unit is resetting the OGM tape.
- ② MEMO/2 WAY button
Used to record a message memo or a telephone conversation.
- ③ FF (Fast forward) button
Used to fast forward the Incoming Message cassette tape.
- ④ OGM REC (Recording) button
Used to record the Outgoing Message.
- ⑤ OGM PLAY button
Used to play the recorded Outgoing Message.
- ⑥ ICM ERASE button
Used to erase the recorded Incoming Messages.
- ⑦ REW (Rewind) button
Used to rewind the Incoming Message cassette tape.
- ⑧ TIME DAY CHECK button
Used to announce the day and time.
- ⑨ Transfer (TRANS.) OGM button
Used to select the Transfer OGM mode.
- ⑩ OGM SELECT button
Used to select OGM mode 1 or 2. The display indicates the selected OGM. While the OGM tape is rewinding or forwarding, the selected OGM's indication on the display will flash.
- ⑪ TRANSFER button
This is the memory station for storing the transfer telephone number.
- ⑫ Liquid Crystal Display
- ⑬ NEW MESSAGE button
Used to play back the newly recorded messages.
- ⑭ PLAYBACK/PAUSE button
Used to play back the recorded Incoming Messages and to stop the ICM tape temporarily during ICM playback.
- ⑮ Volume selector
- ⑯ ANSWER indicator
- ⑰ IN USE indicator
- ⑱ AC Jack (Power)
- ⑲ Telephone line jack
- ⑳ Ringer volume selector (See page 10.)
- ㉑ Dialing mode selector
Used to change the dialing mode tone/pulse. (See page 10.)

Location of Controls (cont.)

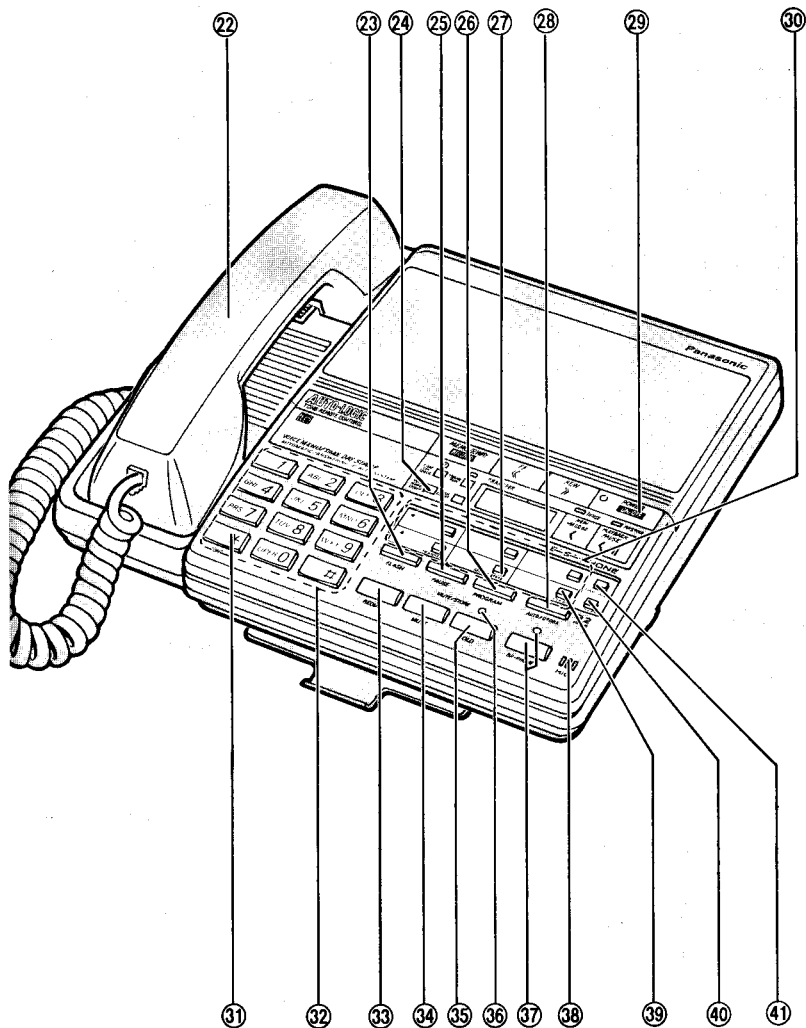

- 22 Handset
- 23 FLASH button
Used to access some of the features of your host PBX.
- 24 VOICE MEMO CHECK button
Used to confirm the stored telephone numbers in the memory stations.
- 25 PAUSE button
Used to enter a pause in phone numbers when programming or dialing.
- 26 PROGRAM button
Used to start and complete the programming procedures.
- 27 SECRET STORE button
Used to store the secret telephone numbers into memory. This button is also used as a direct call station button.
- 28 AUTO/STORE button
Used to program phone numbers and settings into memory.
- 29 POWER ON/OFF button and indicator
Used to turn on and off the unit. The indicator lights when the unit is turned on.
- 30 Direct call buttons
Used to store phone numbers and to make calls using one-touch dialing easily.
- 31 TONE button
Used to change from pulse dialing mode to tone dialing mode while dialing.
- 32 Dial key pads
Used to dial or program phone numbers.
- 33 REDIAL button
Used to redial the last dialed phone number.
- 34 MUTE button
Used when you do not want your voice to be heard by the other party. The voice of the calling party will still be heard.
- 35 HOLD button
Used to put the calling party on hold during a conversation. While holding, the HOLD indicator flashes.
- 36 MUTE/STORE (HOLD) indicator
- 37 SP-PHONE button and indicator
- 38 Microphone (MIC)
- 39 CLEAR button
Used to correct the telephone number while storing.
- 40 LOWER button
Used to select the lower memory locations.
- 41 TIME Adjust (ADJ.) button
Used to set the time and day.

Inserting the Tapes

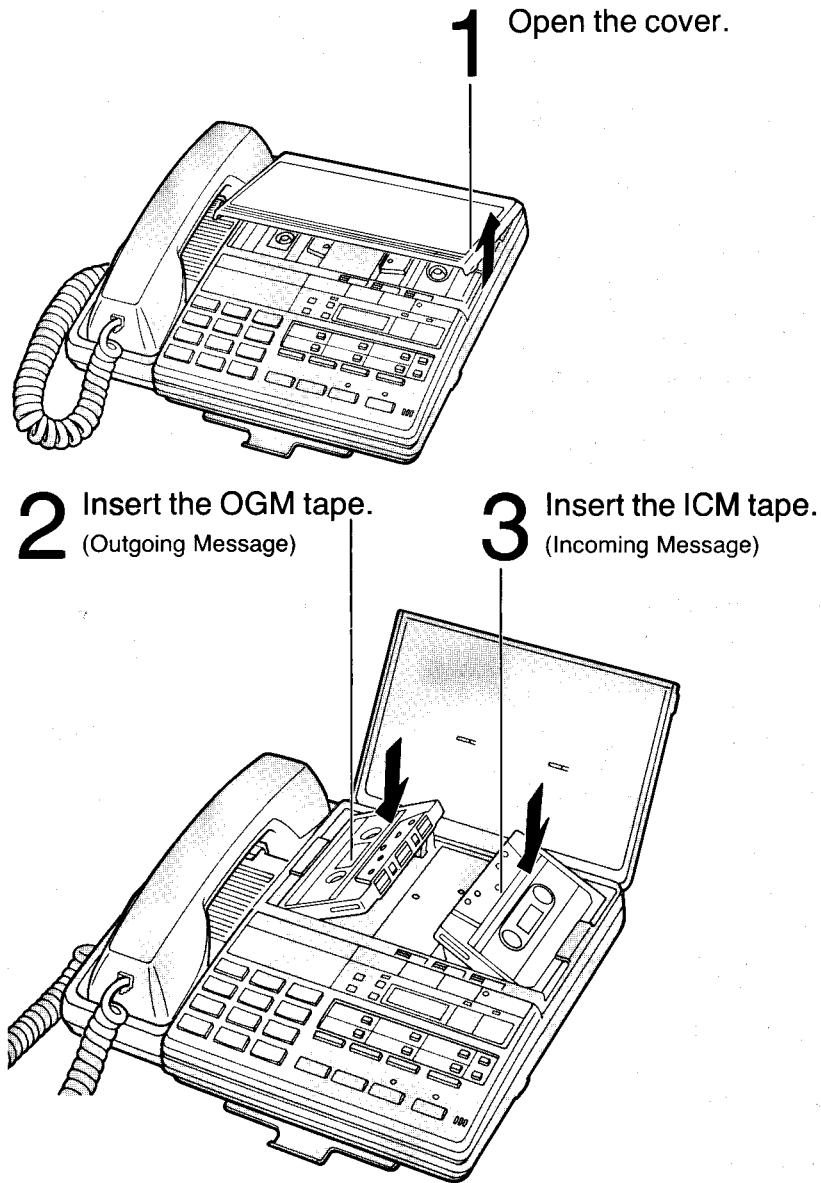

Use Panasonic tapes:

KX-C150, KX-C300... OGM tape
KX-C600, KX-C900... ICM tape

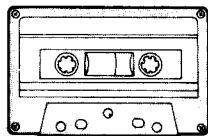

Connection

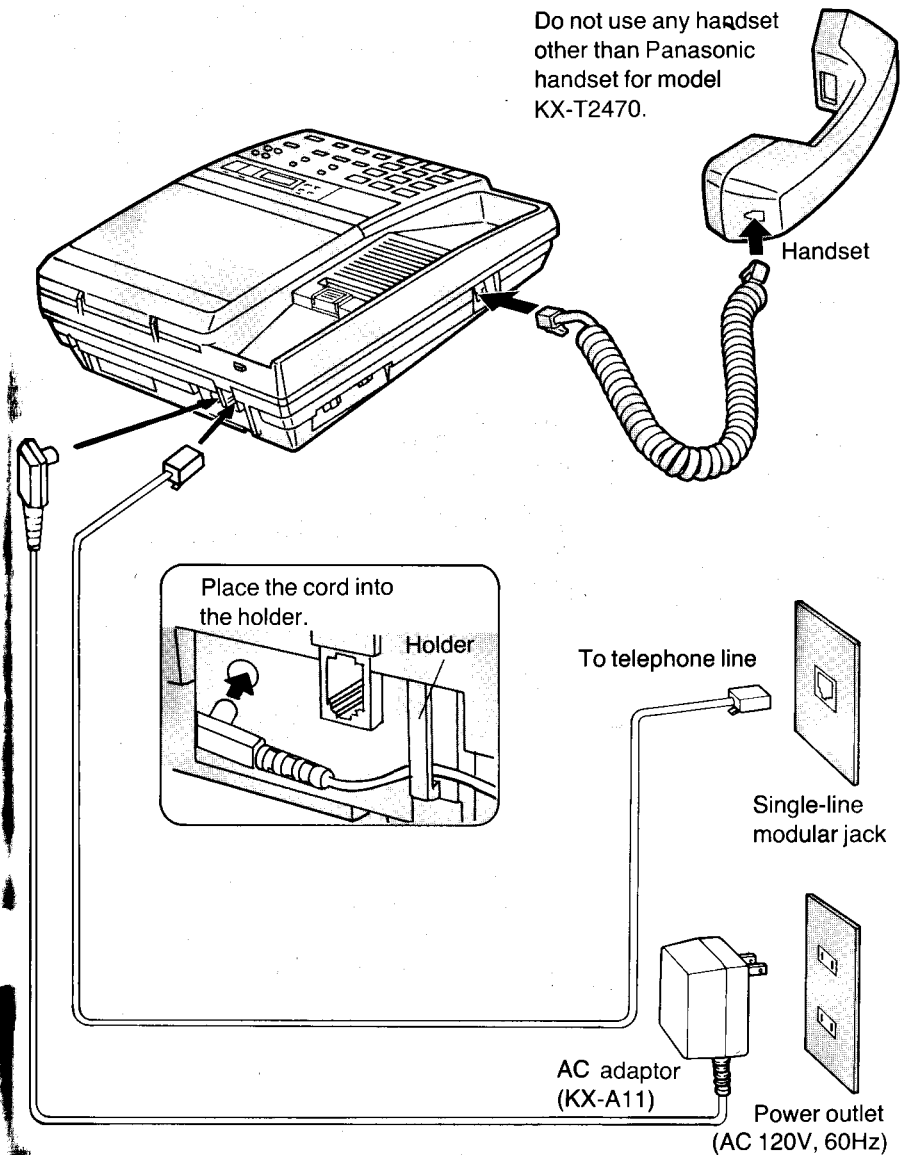

Preparation

- Be sure to insert the tapes before connecting the AC adaptor.
- **USE ONLY Panasonic AC ADAPTOR KX-A11.** If a power failure takes place, the unit can be used as a typical telephone.
- The unit will automatically turn itself on 3 minutes after the AC adaptor is connected.
- While operating the unit, the case of the AC adaptor may feel warm. This is a normal condition.

Initial Settings

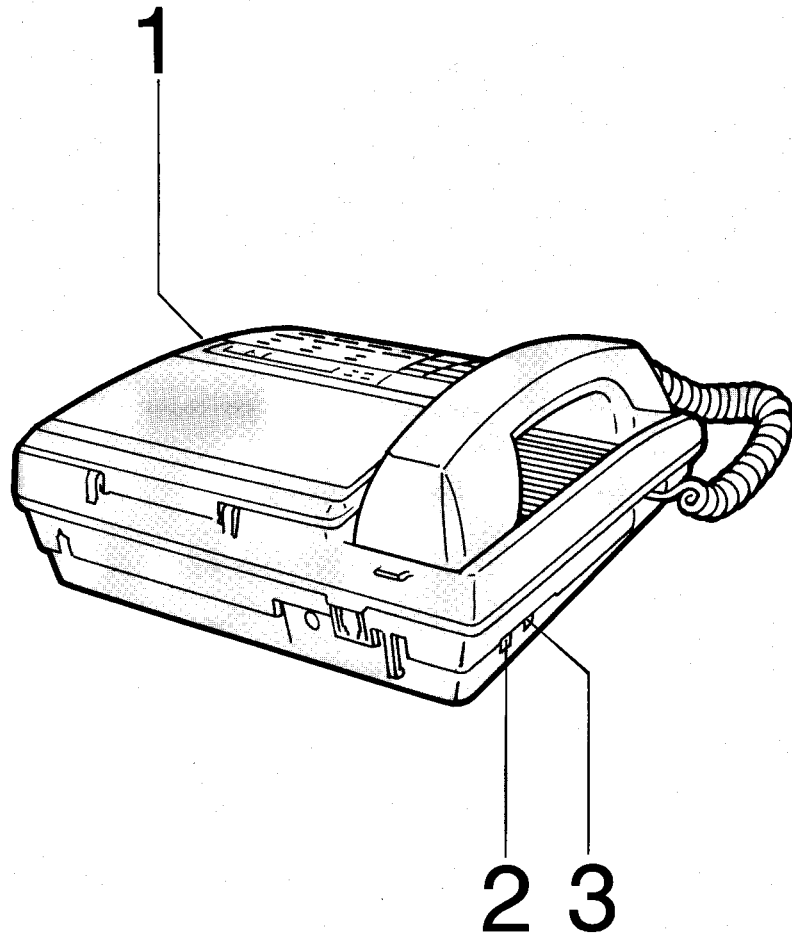

1 Volume Control

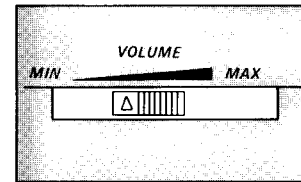

Adjust the Volume.
The central position is usually the best.

2 Ringer volume

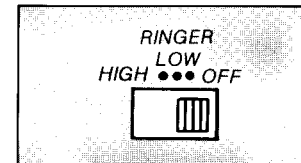

- **HIGH:** The ringing sound will be high.
- **LOW:** The ringing sound will be low.
- **OFF:** The telephone will not ring.

3 Dialing mode

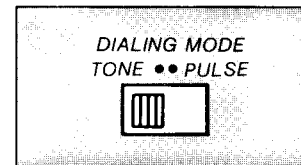

- Set to TONE.
- Set to pulse if you have rotary telephone service. Switching from pulse to tone mode during a dialing operation, see "Tone" on page 35.

Setting the Time and Day

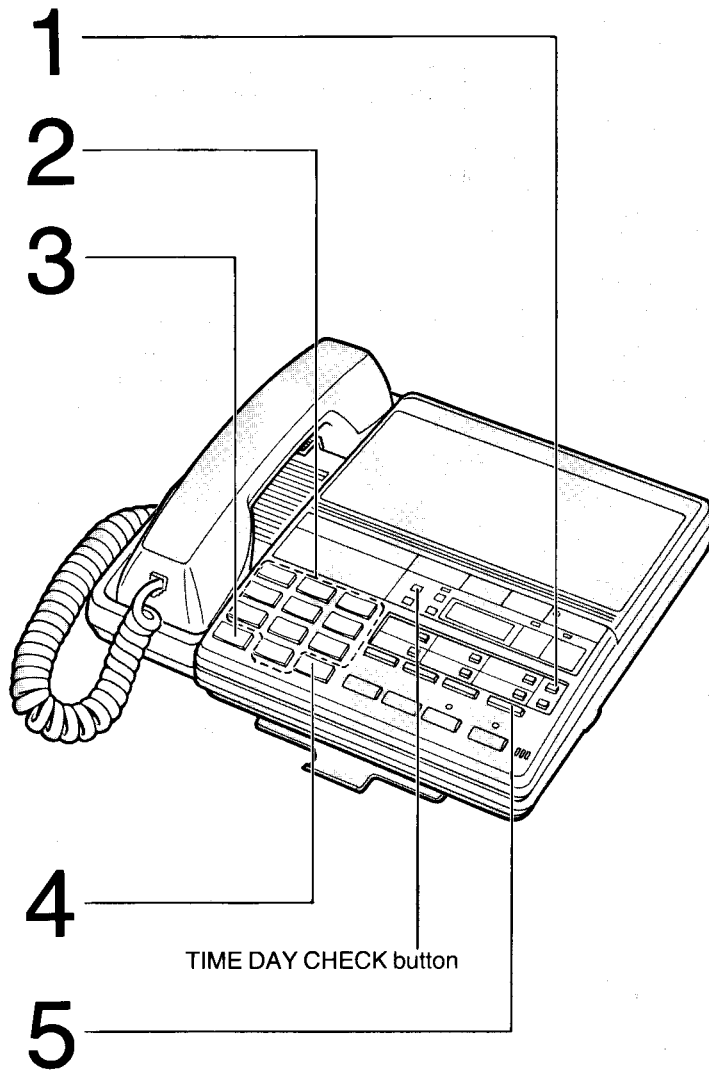

- If a power failure has taken place, the indication "AM 12:00" on the display will flash.
In this case, set the correct time.

Be sure that the handset is on the cradle, the SP-PHONE indicator is off and the AC adaptor is connected. (Example: 8:45 PM)

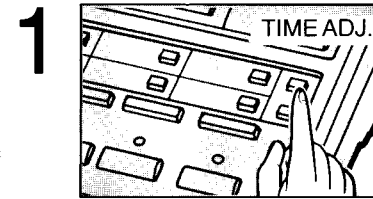

1 Press the TIME ADJ. (Time Adjust) button.

The display shows "AM 12:00" (initial setting).
The MUTE/STORE indicator lights.

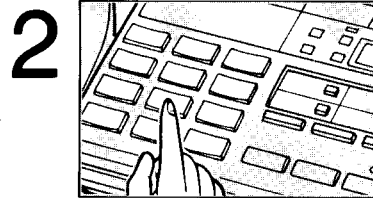

2 Enter the current time "8 4 5" for example.

The display shows "AM 08:45".

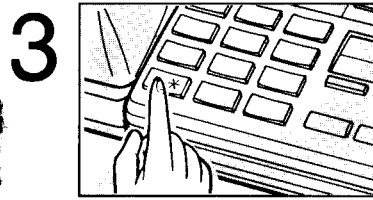

3 Press "*" to adjust AM/PM.

PM and AM are changed alternately each time you press "*" button.

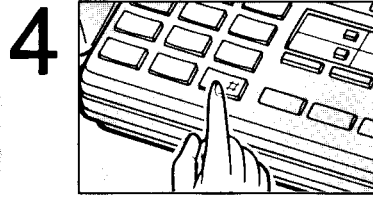

4 Press "#" to adjust the day.

The day is changed and announced each time you press "#" button.

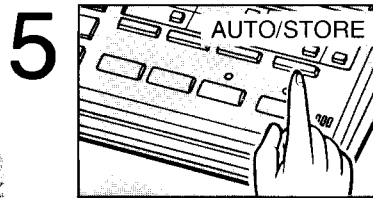

5 Press the AUTO/STORE button to enter your settings.

The day and time is announced.

Confirming the time and day

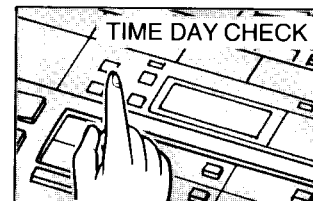

Press the TIME DAY CHECK button.

The day and time is announced.
The accuracy of the clock will be approximately ± 45 seconds a month at room temperature.

Initial Programming

Selecting the CPC (Calling Party Control)

The initial setting of the CPC mode is "A".

- **"A" mode:** Use this mode if your telephone line does not have call waiting service.
 - **"B" mode:** Use this mode if your telephone line has call waiting service.
- If some Incoming Messages are cut off in mode "A", set the mode to "B".

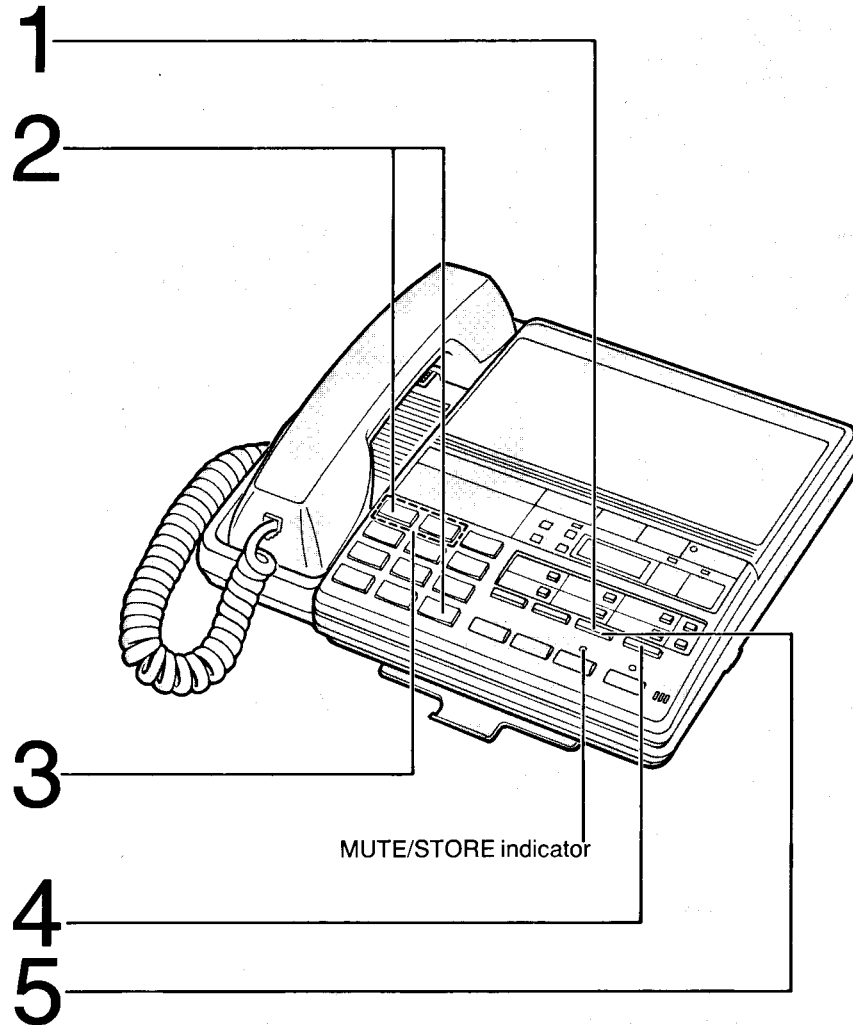

Be sure that the handset is on the cradle, the SP-PHONE indicator is off and the AC adaptor is connected.

1

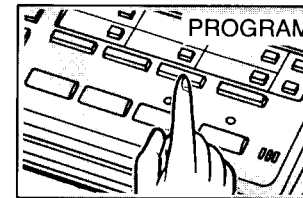

Press the PROGRAM button.
The MUTE/STORE indicator lights.

2

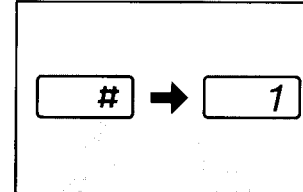

Press "#", then press "1" for
CPC setting.
The MUTE/STORE indicator goes out.

3

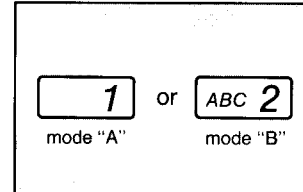

Press "1" or "2".
"1"...mode "A" (The display shows "A".)
"2"...mode "B" (The display shows "b".)

4

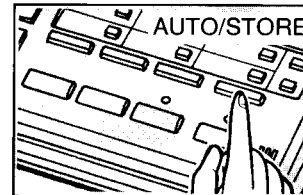

Press the AUTO/STORE button
to store your settings.
The MUTE/STORE indicator lights.

5

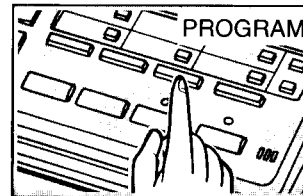

Press the PROGRAM button.
The MUTE/STORE indicator goes out.

Initial Programming (cont.)

Selecting the number of rings

It is used to select the number of rings when this unit answers the calls. The initial setting of the number of rings is "2 rings".

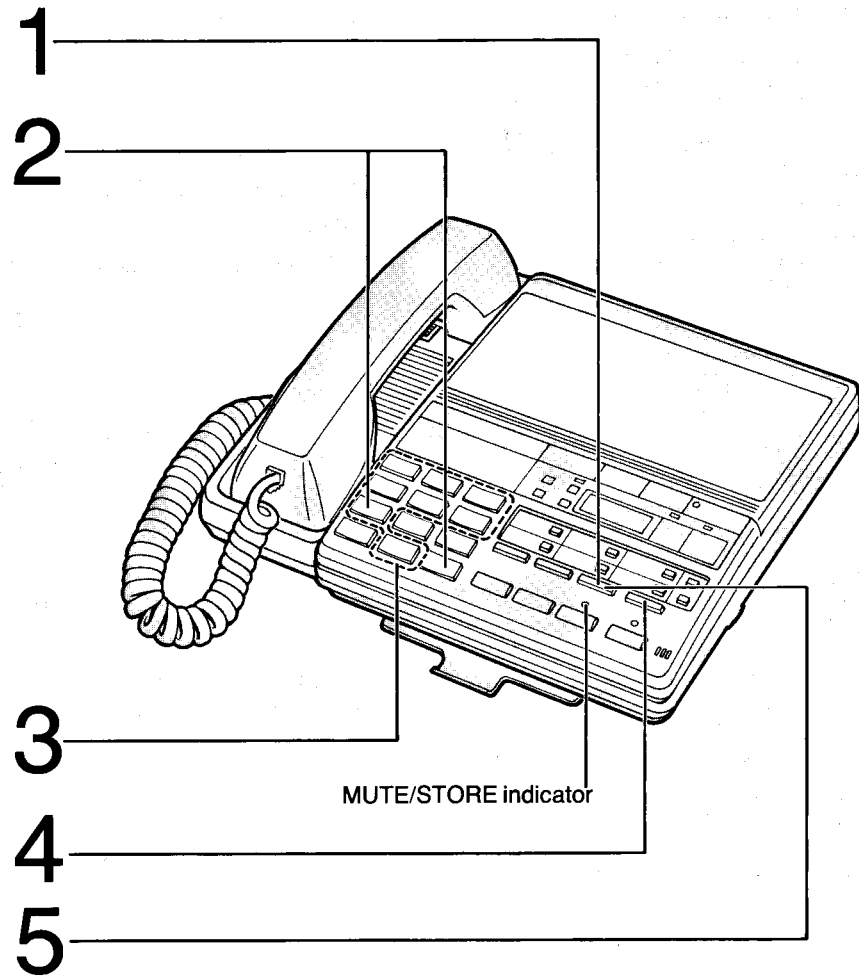

Function of the AUTO setting (TOLL SAVER)

When you call the unit from an outside phone, the number of rings that it takes for the unit to answer tells you if there are any new messages.

If the unit answers on the 2nd ring: There is at least one new message.

If the unit answers on the 4th ring: There are no new messages.

Hang up immediately when you hear the 3rd ring. Because the 3rd ring indicates there are no new messages. This will save you the toll charge for the call.

Be sure that the handset is on the cradle, the SP-PHONE indicator is off and the AC adaptor is connected.

1

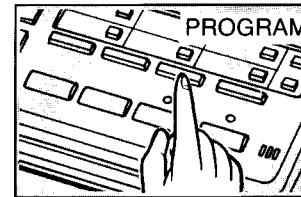

Press the PROGRAM button.
The MUTE/STORE indicator lights.

2

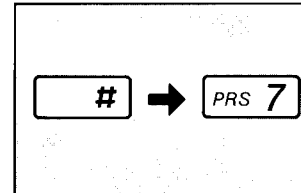

Press "#", then press "7" for number of rings setting.
The MUTE/STORE indicator goes out.

3

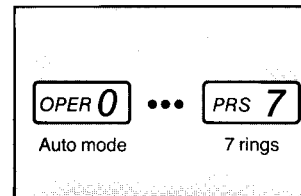

Select the number of rings by pressing "0", "1", "2"...or "7".
"0"...auto mode (The display shows "A".)
See "AUTO setting" on page 15.
"1"...one ring (The display shows "1".)
"2"...two rings (The display shows "2".)
:
"7"...seven rings (The display shows "7".)

4

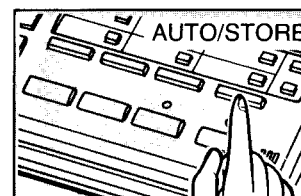

Press the AUTO/STORE button to store your settings.
The MUTE/STORE indicator lights.

5

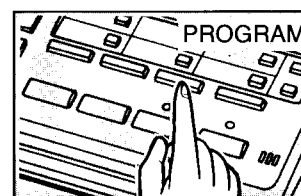

Press the PROGRAM button.
The MUTE/STORE indicator goes out.

Initial Programming (cont.)

Selecting the caller's recording time

The caller's recording time can be programmed to "VOX", "1 Minute" or "Announce only".

The initial setting of the recording time is "VOX (unlimited)".

- **"VOX (Unlimited)" mode:** The recording time is limited by the length of the tape.
- **"1 Minute (Limited)" mode:** It allows the caller to record for 1 minute.
- **"Announce only" mode:** The unit plays back the OGM only and will not record any Incoming Messages.

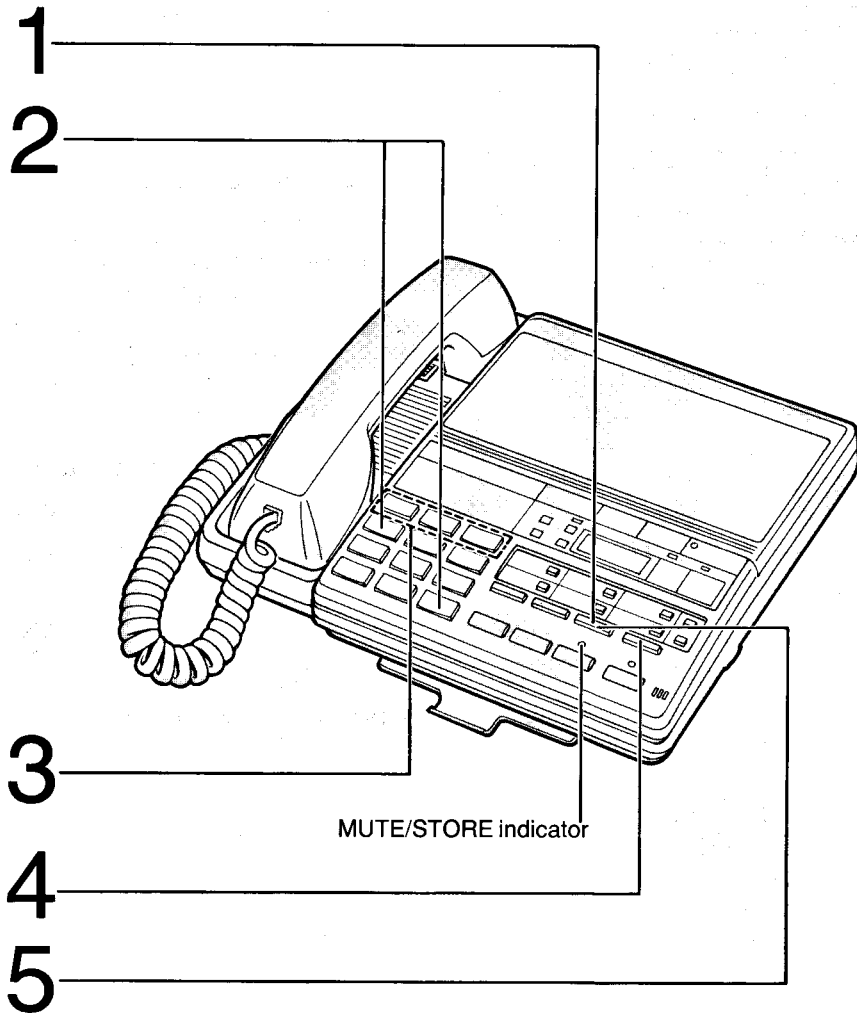

MUTE/STORE indicator

Be sure that the handset is on the cradle, the SP-PHONE indicator is off and the AC adaptor is connected.

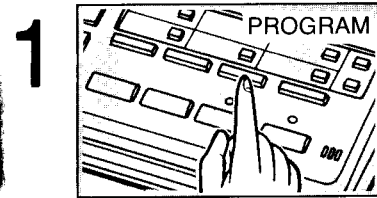

Press the PROGRAM button.
The MUTE/STORE indicator lights.

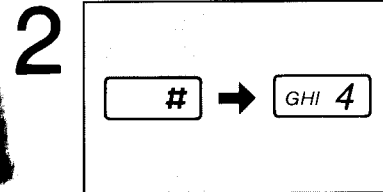

Press "#", then press "4" for caller's recording time setting.
The MUTE/STORE indicator goes out.

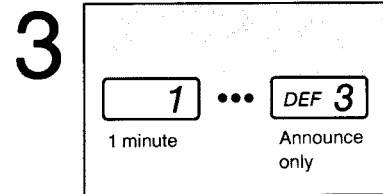

Select the recording time by pressing "1", "2" or "3".

"1"...1 minute (The display shows "L".)
"2"...VOX (The display shows "UL".)
"3"...Announce only
(The display shows "AO".)

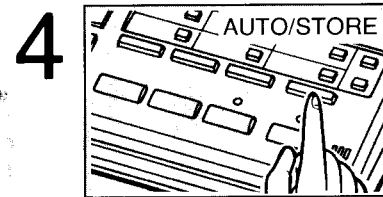

Press the AUTO/STORE button to store your settings.
The MUTE/STORE indicator lights.

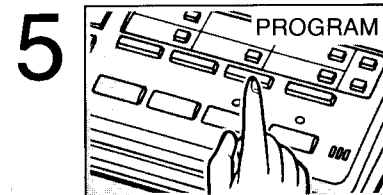

Press the PROGRAM button.
The MUTE/STORE indicator goes out.

Initial Programming (cont.)

Setting the remote code

Before operation, choose a 1~3-digit remote code number (1 through 999) and store it in memory.

The initial setting of the remote code is "111".

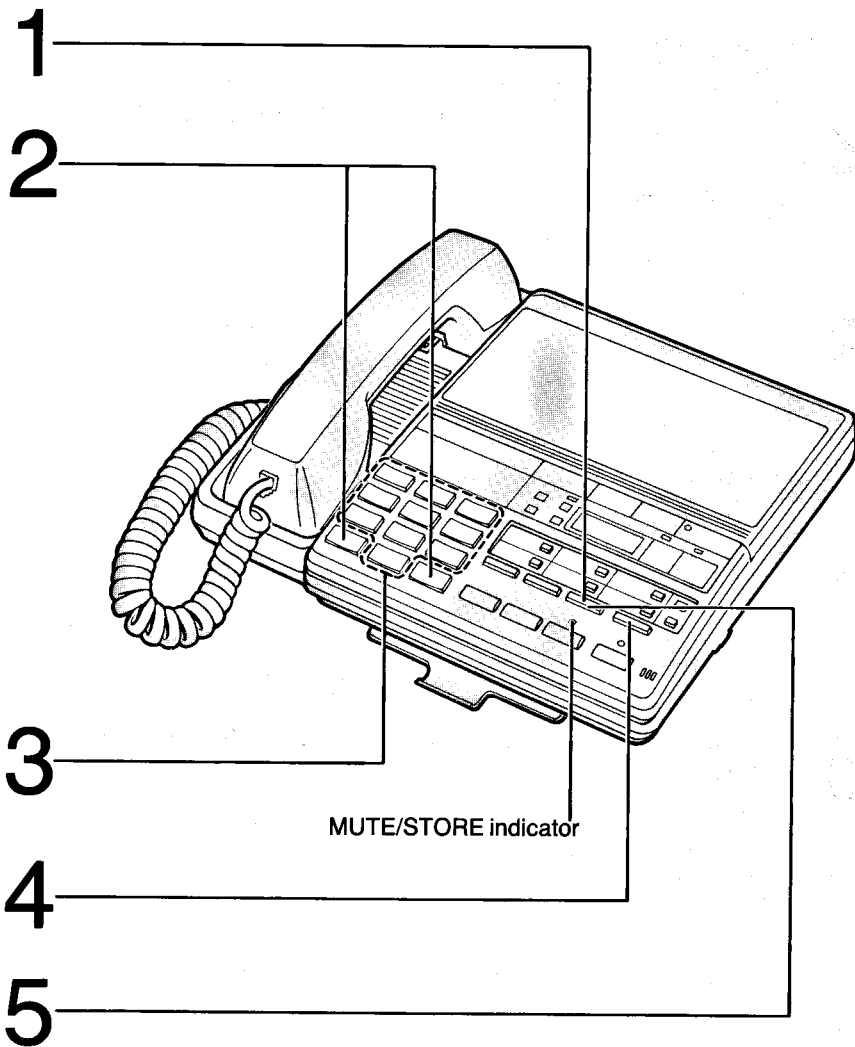

Be sure that the handset is on the cradle, the SP-PHONE indicator is off and the AC adaptor is connected.

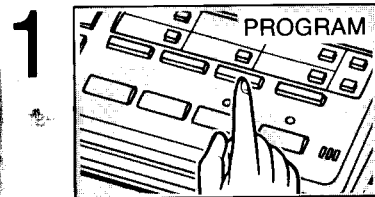

1 Press the PROGRAM button.
The MUTE/STORE indicator lights.

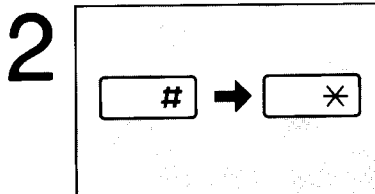

2 Press "#", then press "*" for remote code setting.
The MUTE/STORE indicator goes out.

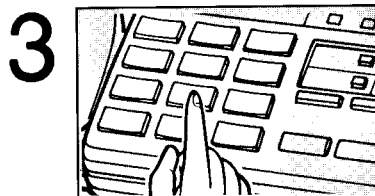

3 Enter your code number.
The display shows the entered code.

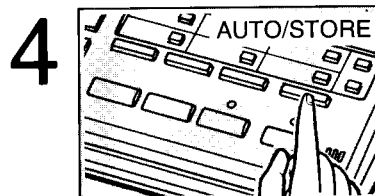

4 Press the AUTO/STORE button to store your settings.
The MUTE/STORE indicator lights.

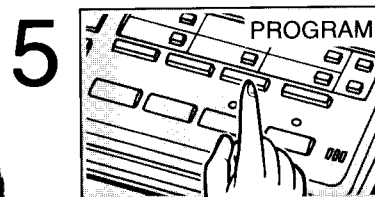

5 Press the PROGRAM button.
The MUTE/STORE indicator goes out.

- Do not use the number "7", "8" and "0" as your code number, since these numbers are the command numbers for "Re-recording the OGM" and "Canceling the answer mode".
- If you notice an error during programming, press the PROGRAM button and then repeat the programming procedure.

Recording an Outgoing Message (OGM)

The OGM tells the caller that you are out, and asks to leave a message. You can record two OGMs.

- **OGM 1**'s recording time is limited to 30 seconds. So you may leave a short message.
- **OGM 2** is an extended OGM and its recording time may be up to the end of the tape. You may leave a long message, such as advertisement for your business.

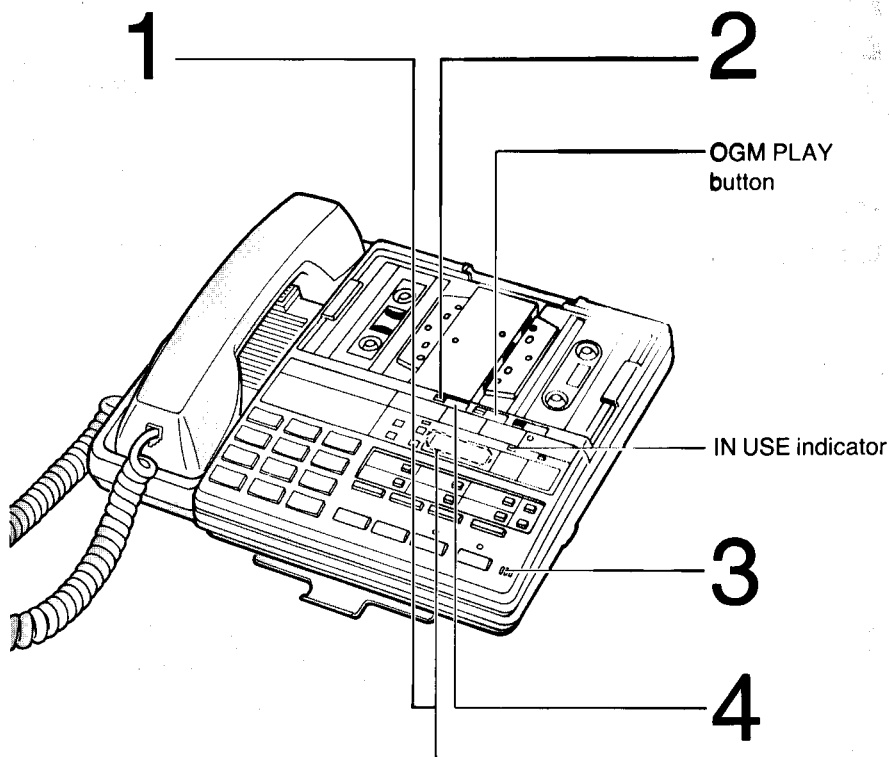

OGM indicators

OGM 1 is selected.

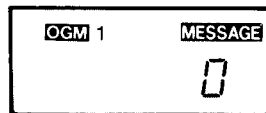

OGM 2 is selected.

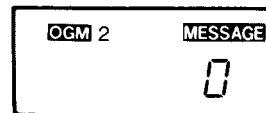

OGM SELECT button (for selecting OGM mode 1 or 2)

OGM 1 or 2 is recorded or played depending on the selection. The OGM mode will change alternately everytime you press the OGM SELECT button.

Recording an OGM

Press the POWER ON/OFF button to turn on the unit. (The POWER indicator lights.)

1

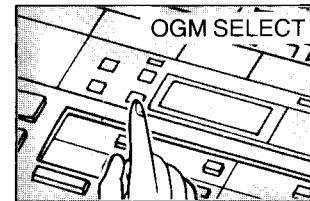

Press the OGM SELECT button.

The unit announces "One" or "Two". The selected OGM's indication on the display flashes at first, then it will switch to a steady light after the OGM tape has been reset.

2

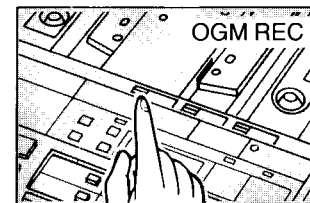

Press the OGM REC button until a long beep is heard, then release it.

The IN USE indicator flashes. The display counts the seconds that you use for your OGM recording.

3



Start recording at once.

Speak loudly and clearly right after the beep, about 20 cm (8") away from the microphone (MIC).

Do not pause for over 2 seconds. If you hear 6 beeps and the announcement "Please record your Outgoing Message again", start over again from step 2 after the unit stops rewinding.

4

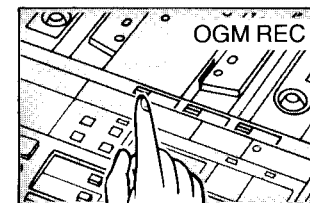

Press the OGM REC button again when you finished recording.

The tape rewinds, and the unit will be ready to answer incoming calls after 7 seconds.

Recording an Outgoing Message (cont.)

Checking your recorded message (OGM)

1

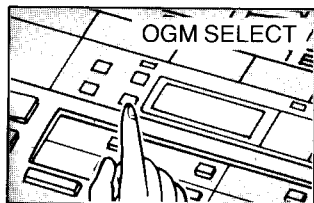

Press the OGM SELECT button (OGM 1 or OGM 2).

The unit announces "One" or "Two". The selected OGM's indication on the display flashes at first, then it will switch to a steady light after the OGM tape has been reset.

2

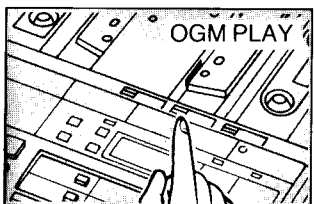

Press the OGM PLAY button to listen to your recorded OGM.

Press the OGM PLAY button again if you want to stop the operation at any time. The tape rewinds, and the unit will be ready to answer incoming calls after 7 seconds.

Sample OGMs

When the ICM recording time is set to "VOX"

(See pages 17 and 18.)

Example: "Hello. This is Dick Smith. I'm not here now, but if you leave your name and phone number after the beep, I'll call you back. Thank you."

Example: "This is Smith Appliances. Our offices will be closed until nine o'clock in the morning. Please leave a message with your name and telephone number after the beep, and we will return your call as soon as possible. Thank you."

When the ICM recording time is set to "1 MIN"

(See pages 17 and 18.)

Example: "Hello, this is Dick Smith. I'm out now, but if you leave a message after the beep, I'll call you back. **You have one minute for recording.** Thank you."

When the ICM recording time is set to "ANN. ONLY"

(See pages 17 and 18.)

Example: "Hello, this is the Smith residence. Sorry to miss your call, but we can't come to the phone right now. If you call back tomorrow, we'll be happy to talk to you. Thanks."

Telephone

Manual Dialing and Receiving	25
Making calls using the handset	25
Making calls using the SP-PHONE button (on-hook dialing)	25
Answering calls	25
Automatic Dialing	26
Speed dialing	26
One-touch dialing	26
Storing telephone numbers for speed dialing	27
Storing telephone numbers for one-touch dialing	28
Storing telephone numbers with secret features	29
Correcting an error while storing	30
Confirming a stored number	30
Erasing a stored number	31
Voice Memo Check	32
Other Operation	33
Redial	33
Mute, Hold	34
Tone, Flash	35
Pause	36
Combination Dialing	37

Manual Dialing and Receiving

Making calls using the handset

- 1 Lift the handset.
- 2 Dial the telephone number.

Making calls using the SP-PHONE button (on-hook dialing)

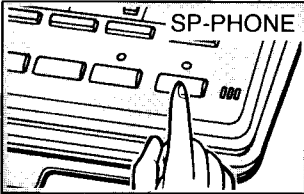
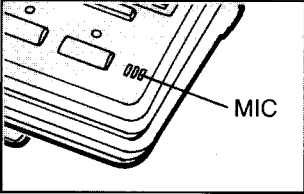
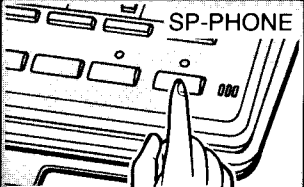
-  **1** Press the SP-PHONE button, and dial the telephone number. The SP-PHONE indicator lights.
-  **2** When the other party answers, speak to the other party through the microphone. You can also switch to the handset at any time by just lifting it.
-  **3** Press the SP-PHONE button again when you finish. The SP-PHONE indicator goes out.

Helpful hints

- **When the other party finds it difficult to hear your voice:**
Lower the sound level using the speaker volume control or speak louder.
- **Absorbing echo:**
Use in a room which has curtains or carpeting.

Answering calls

When the telephone rings, lift the handset or press the SP-PHONE button and speak to the calling party.

While speaking with handset, you can switch to the speakerphone at any time by pressing the SP-PHONE button. Replace the handset on the cradle.

Automatic Dialing

Before using speed dialing and one-touch dialing, store the telephone numbers into the memory stations. See pages 27 and 28.

Speed dialing

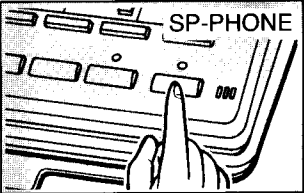
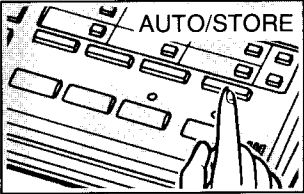
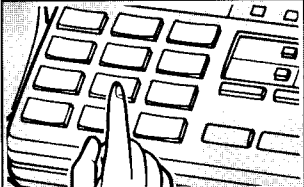
-  **1** Lift the handset or press the SP-PHONE button.
-  **2** Press the AUTO/STORE button.
-  **3** Press the station number (01~20) in which the number you want to call is stored.

One-touch dialing

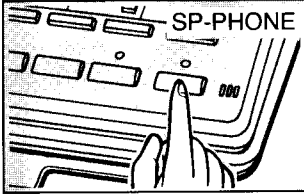
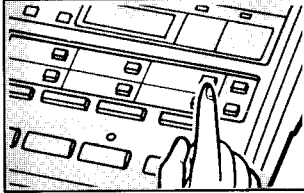
-  **1** Lift the handset or press the SP-PHONE button.
-  **2** Press the direct call button in which the number you want to call is stored.
Press the LOWER button first for dialing the number stored into the lower memory location.
If you press the LOWER button by mistake when you want to use the upper location, start over again from step 1.

Automatic Dialing (cont.)

Be sure that the handset is on the cradle, the SP-PHONE indicator is off and the AC adaptor is connected.

When you store a telephone number into memory, pressing the #, *, PAUSE or FLASH button count as 1 digit.

Storing telephone numbers for speed dialing

There are 20 memory stations, each memory station can be accessed by dialing 2 digits on the dial key pad. (01~20)

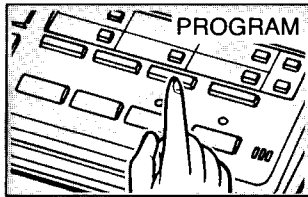
- 

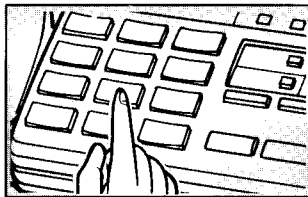
1 Press the PROGRAM button.
The MUTE/STORE indicator lights.
- 

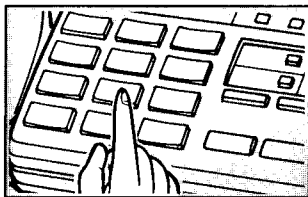
2 Press the station number (01~20).
The MUTE/STORE indicator goes out.
- 

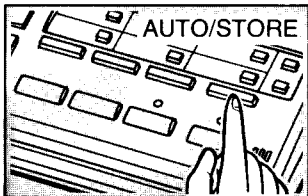
3 Dial the telephone number that you want to store.
Up to 16 digits.
- 

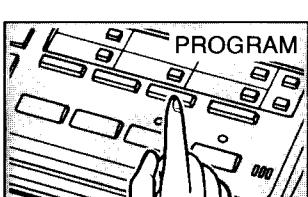
4 Press the AUTO/STORE button to store the number into memory.
The MUTE/STORE indicator lights.
To store other numbers in succession, repeat from step 2.
- 

5 Press the PROGRAM button after storing all the numbers.
The MUTE/STORE indicator goes out.

Storing telephone numbers for one-touch dialing

There are 6 direct call buttons. Each button consists of upper and lower memory locations. Each location (upper and lower) is capable of storing 16 digits. (TRANSFER station is capable of storing 30 digits.)

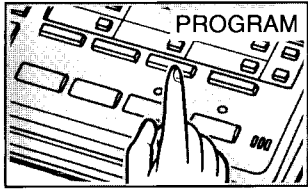
- 

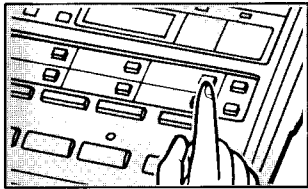
1 Press the PROGRAM button.
The MUTE/STORE indicator lights.
- 

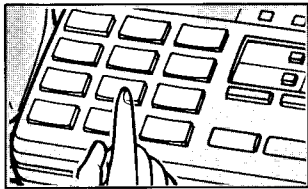
2 Press the direct call button.
The MUTE/STORE indicator goes out.
- 

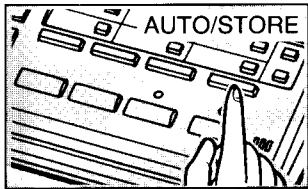
3 Dial the telephone number that you want to store.
Up to 16 digits.
- 

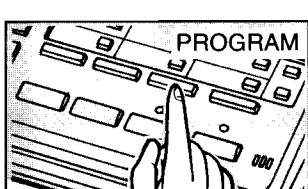
4 Press the AUTO/STORE button to store the number into memory.
The MUTE/STORE indicator lights.
To store other numbers in succession, repeat from step 2.
- 

5 Press the PROGRAM button after storing all the numbers.
The MUTE/STORE indicator goes out.

Using the LOWER memory location

Other telephone numbers can be stored into the LOWER memory locations of the same direct call stations. In this case, change step 2 of the above procedure by first pressing the LOWER button, then press the direct call button.

Automatic Dialing (cont.)

Storing telephone numbers with secret feature

This function is useful for keeping a telephone number secret. Press the SECRET STORE button instead of pressing AUTO/STORE button during programming.

The secret telephone number will not be seen on the display and will not be announced by voice memo check. (See page 32.)

Example: To store the secret telephone number into the memory station "02".

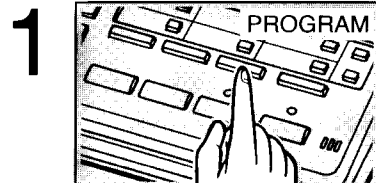

Press the PROGRAM button.

The MUTE/STORE indicator lights.

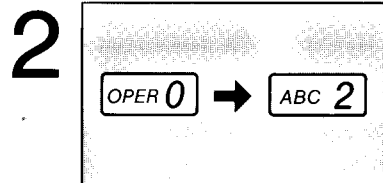

Press the station number "02".

The MUTE/STORE indicator goes out.

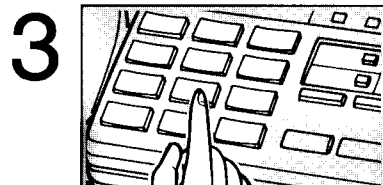

Dial the telephone number that you want to save.

Up to 16 digits.



Press the SECRET STORE button to store the number into memory.

The MUTE/STORE indicator lights.

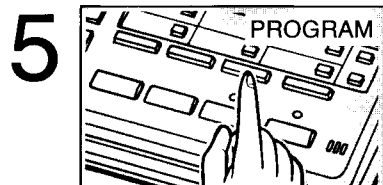

Press the PROGRAM button.

The MUTE/STORE indicator goes out.

Correcting an error while storing

If you notice an error before pressing the AUTO/STORE button (or the SECRET STORE button):

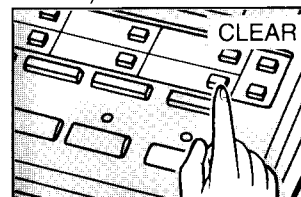

Press the CLEAR button.

Repeat from step 2 of the programming procedure on page 27 to 29.

Confirming a stored number

Repeat storing the same number into the same station. When the AUTO/STORE button (or the SECRET STORE button) is pressed, the MUTE/STORE indicator flashes and you hear a beep.

- Twice
The entry is the same as what was previously stored.
- Once
The entry is different from the one that was previously stored. Repeat the procedure of storing.

NOTE:

In case the AC adaptor is unplugged for more than 30 minutes, the stored telephone numbers should be confirmed again before dialing.

Automatic Dialing (cont.)

Erasing a stored number

Erasing a number stored for one-touch dialing

1

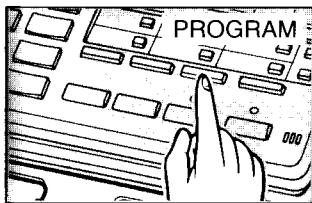

Press the PROGRAM button.
The MUTE/STORE indicator lights.

2

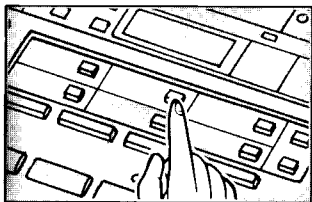

Press the direct call button where
the number that you want to
erase is stored.
The MUTE/STORE indicator goes out.

3

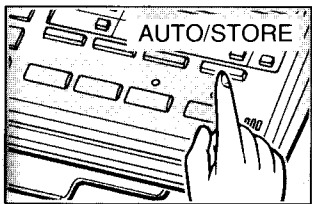

Press the AUTO/STORE button.
The MUTE/STORE indicator lights.

4

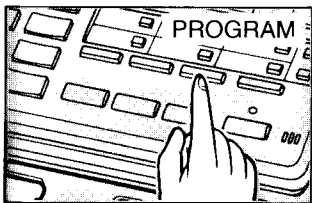

Press the PROGRAM button.
The MUTE/STORE indicator goes out.

Erasing a number stored for speed dialing

When you want to erase the telephone number for speed dialing, change step 2 of the above procedure by pressing the station number (01~20).

Voice Memo Check

You can confirm the stored telephone number with the synthesized voice announcement by pressing the VOICE MEMO CHECK button.

1

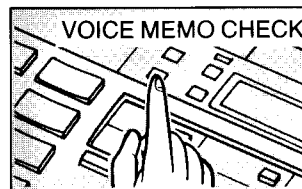

Press the VOICE MEMO
CHECK button.

2

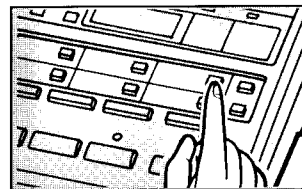

Press the direct call button or the
station number (01~20) in which
the number that you want to
check is stored.

The telephone number is announced and
displayed one by one.

- The unit announces only the stored telephone number and does not announce "PAUSE", "FLASH", "x" and "#".
- The secret telephone number will not be seen on the display and will not be announced by voice memo check.



Other Operation

Redial

The last dialed number will be stored into memory up to 30 digits. The REDIAL button allows the unit to redial the number automatically.

When using a handset

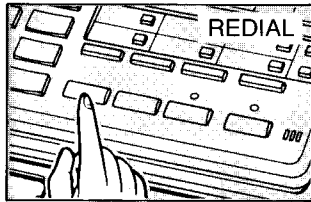

Lift the handset, and press the REDIAL button.

You can redial once.

When using the SP-PHONE button (Automatic redial)

1

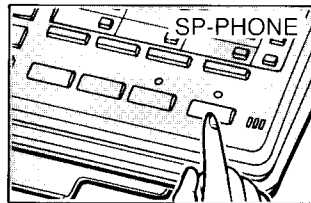

Press the SP-PHONE button.

The SP-PHONE indicator lights.

2

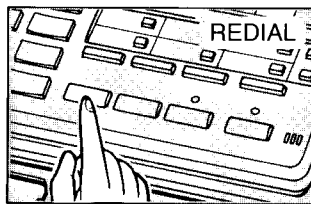

Press the REDIAL button.

If the line is busy, the unit will redial automatically up to 15 times within a 10-minute period. (Automatic redial)

Automatic redial will be canceled in the following cases:

- In case you press the FLASH button.
- In case you press the SP-PHONE button or lift the handset (off-hook).

Mute

The MUTE button is used when you do not want your voice to be heard by the other party. The other party's voice can be heard.

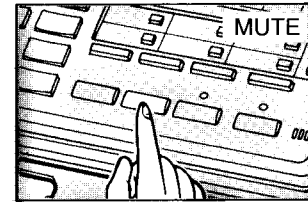

Press the MUTE button.

The MUTE/STORE indicator lights.
To resume the conversation, press the MUTE button again.

Hold

The HOLD button is used to keep a call on hold while having a conversation.

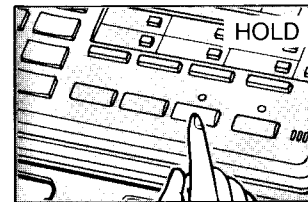

Press the HOLD button while in conversation.

The HOLD indicator flashes.
You may place the handset on the cradle.

Releasing a hold

- **If the handset is off-hook:**
Press the HOLD button.
- **If the handset is on the cradle:**
Lift the handset or press the SP-PHONE button.
- **When using another telephone connected on the same line:**
Lift the handset of the other telephone.
If the hold is not released, press the hookswitch of the other telephone for about one second.

telephone

Other Operation (cont.)

Tone

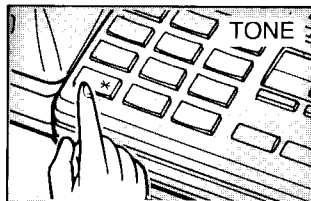

Use the TONE button when you have rotary telephone service. Pressing it will allow you to change from pulse to tone mode during a dialing operation, and enter special tones and codes to operate answering machines, electronic banking services and other special services.

Flash

Pressing the FLASH button can be used instead of pressing the hookswitch. The FLASH button can be used to access call waiting. For more details, please contact your telephone company.

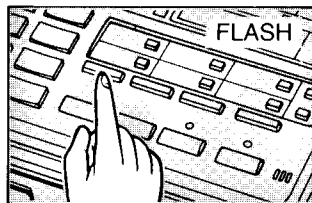

While having a conversation, another party calls and you hear a tone, then press the FLASH button.

The first conversation is placed on hold and the second call can be answered. To speak to the first caller again (the second caller is placed on hold), press the FLASH button again.

- You may access some features of your host PBX using the FLASH button instead of the hookswitch. This could be accomplished by pressing the FLASH button in a dial operation. The FLASH button can be stored into memory the same way as storing the telephone numbers on pages 27 and 28.

Pause

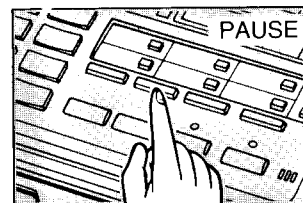

The PAUSE button is used when accessing an outside line. When the PAUSE button is pressed, you can dial the phone number without waiting for an outside dial tone.

One pause is required when waiting for an outside dial tone

Example (PBX):

Storing a phone number into memory station.

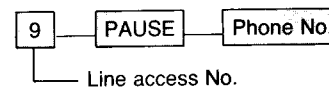

When redialing, a pause may be required by your host PBX.



Combination Dialing

A telephone number with more than 16 digits can be stored into two memory stations. For dialing, follow the next:

- 1 Lift the handset or press the SP-PHONE button.
- 2 Press the station key "1".
- 3 Press the station key "2".

Instead of using two memory stations, you can store a part of the telephone number into one memory station, and the other part can be dialed manually.

- 1 Lift the handset or press the SP-PHONE button.
- 2 Press the station key, wait for dialing to stop, then dial manually.

Answering Machine

Setting the Answering Machine to Record Incoming Messages	39
Recording from the beginning of the ICM tape	40
Recording after the last recorded message	40
Recording after the messages you want to save	40
Listening to the Recorded Messages	41
Voice time/day stamp	41
Playing back the tape from the beginning	42
Playing back the newly recorded messages	42
Voice Menu	43
Remote synthesized voice instruction	43
Going to the voice menu	43
Direct Remote Operation	46
Playing back newly-recorded messages (Memory Playback)	46
Rewinding/fast forwarding while listening to the messages	46
Resetting the ICM tape for future message	47
Recording your message without listening to the OGM	48
Recording a new OGM (Outgoing Message)	49
Changing OGM mode (1 or 2)	50
Turning on the speakerphone (Answer Back)	51
Setting/canceling the answer mode remotely	52
Transferring the ICM	53
Initial programming for transferring ICM	53
Recording the transfer OGM	53
Checking your transfer OGM	54
Storing the telephone number into the transfer memory station	55
Setting the transfer mode	56
Listening to the transferred ICM	57
Storing a transfer number from a remote phone	58
Setting the transfer mode remotely	58
Other Features	59
Recording a personal messages (Message Memo)	59
Recording a conversation (2-Way Recording)	60
Screening incoming calls	61
Erasing the recorded messages	61

Setting the Answering Machine to Record Incoming Messages

Press the **POWER ON/OFF** button to turn on the unit.

(The **POWER** indicator lights.)

After 7 seconds, the unit will be ready to answer the calls.

(Answer mode)

1•2

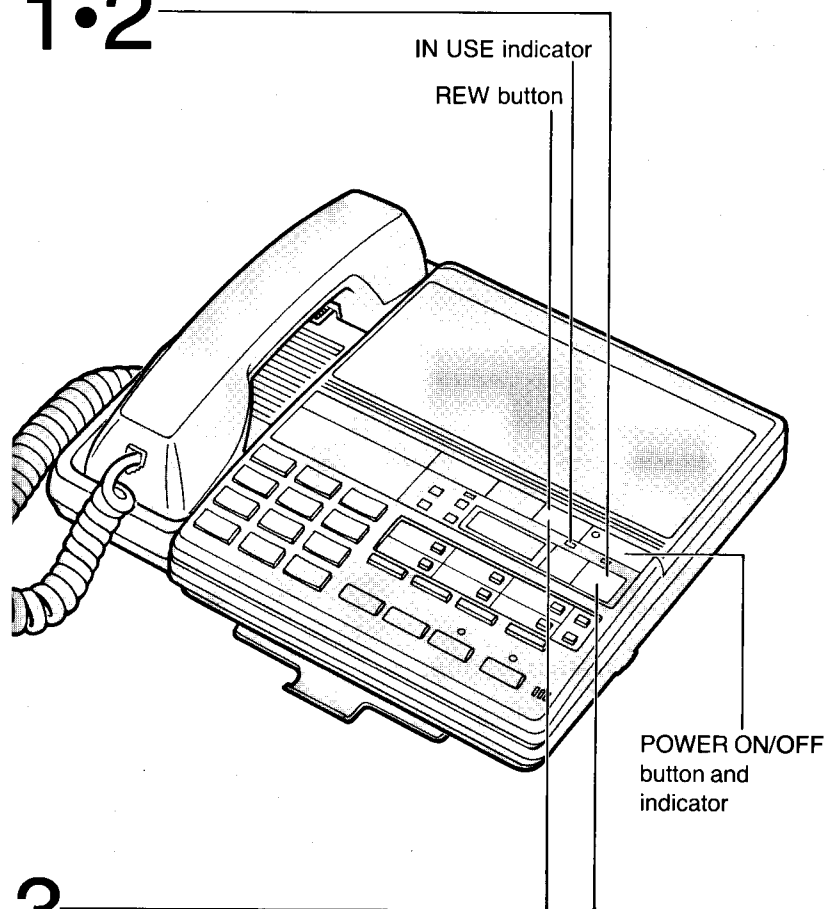

- Answer mode
When a call is received, the unit answers calls.
- To change the recording time, see pages 17 and 18.
- If you do not want the unit to answer the call, press the **POWER ON/OFF** button to turn off the unit. The **POWER** indicator will go out.

Recording from the beginning of the ICM tape

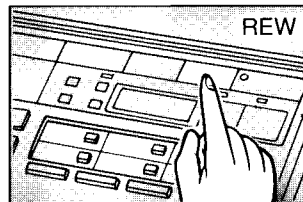

Press the **REW** button to rewind the tape.

The unit will reset and be ready to answer the next call.

Recording after the last recorded message

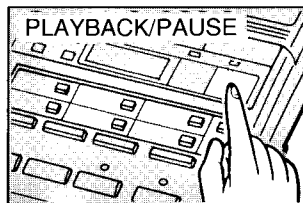

Press the **PLAYBACK/PAUSE** button to play back all the recorded messages.

The unit announces the number of recorded messages.

After playback, "End of final message" will be announced and the unit will automatically be ready to answer the next call. All the recorded messages will be saved.

Recording after the messages you want to save

1

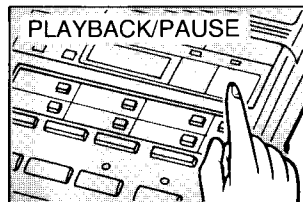

Press the **PLAYBACK/PAUSE** button to play back the tape to the end of the message you want to save.

The unit announces the number of recorded messages.

2

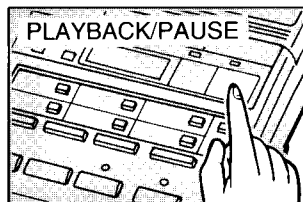

Press the **PLAYBACK/PAUSE** button again to pause the unit.

The **IN USE** indicator flashes. (pause mode)

3

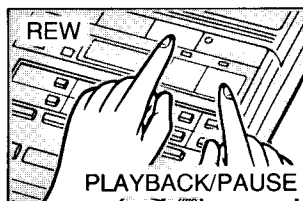

Press the **REW** button and the **PLAYBACK/PAUSE** button simultaneously.

The **IN USE** indicator goes out and the **ANSWER** indicator lights. New calls will be recorded after the message you have saved.

Listening to the Recorded Messages

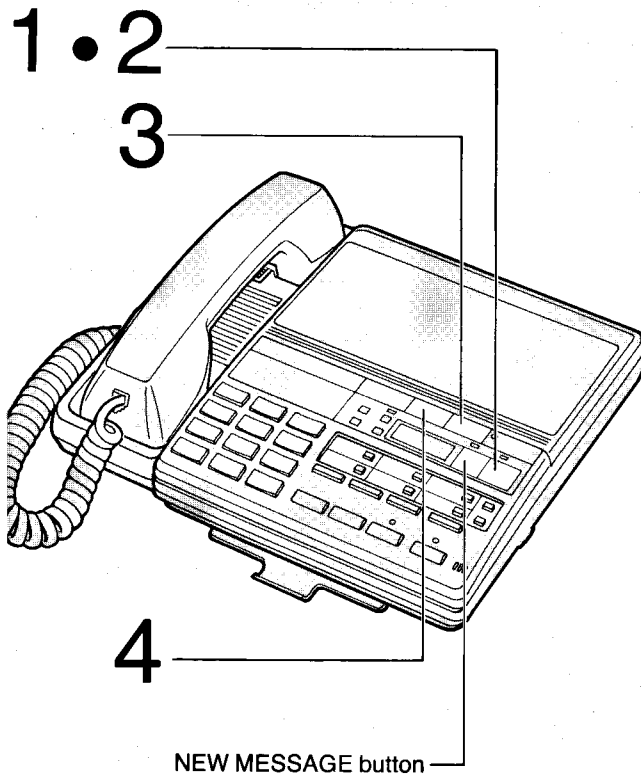

AUTO-LOGIC™ (one-touch operation)

At the touch of the PLAYBACK/PAUSE button or the NEW MESSAGE button, the unit will automatically rewind and play back all the recorded messages or the new messages. At the end of the last message, "End of final message" will be heard. After 7 seconds, the unit will be automatically ready for recording incoming calls. All the recorded messages will be saved.

Voice time/day stamp

When the messages are received, a synthesized voice announcement of the time and day will be recorded on the ICM tape after the recorded messages. If the voice time/day stamp is not recorded after the recorded messages, the time and day must be set again (See pages 11 and 12.).

Playing back the tape from the beginning

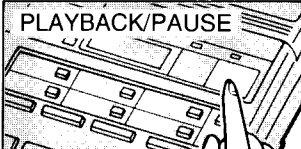
1  Press the PLAYBACK/PAUSE button to rewind the tape and start playing back from the beginning.

The unit announces the number of recorded messages.
Adjust volume, if needed.
After playback, "End of final message" will be announced.

2  Press the PLAYBACK/PAUSE button to stop the tape (pause mode).

The IN USE indicator flashes.
Press the button again to start playback again.

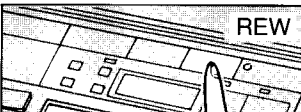
3  Press the REW button to rewind the tape back to the desired location.

Press the PLAYBACK/PAUSE button to listen to the message again.

4  Press the FF button to fast forward the tape to the desired location.

Press the PLAYBACK/PAUSE button to listen to the message.

Playing back the newly recorded messages

Only new messages are played back. (Messages once reviewed will not be played back.)

 Press the NEW MESSAGE button.

The unit announces the number of recorded messages.
The new messages are played back.
After playback, "End of final message" will be announced.

Voice Menu

Remote synthesized voice instruction

You can retrieve the Incoming Messages from a remote location with a tone telephone. The remote operation is simplified by a synthesized voice that offers you options over the telephone.

The synthesized voice will give you the direction how to operate your unit from a remote location using a tone telephone.

Without any manuals you can easily access remote operations such as Memory Playback, Marker Message, etc.

To operate the unit directly skipping the order of the Voice Menu, see pages 46~52.

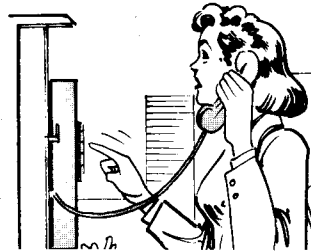

Going to the voice menu

1



Call your unit.

2

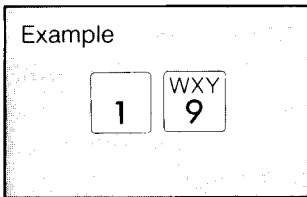

Dial your code number (for example, 19) while the OGM is playing.

The unit announces the number of newly recorded messages.

After 5 seconds the unit will go into the Voice Menu.

The unit announces "Please push 1 for Playback, please push 2 for another function".

3

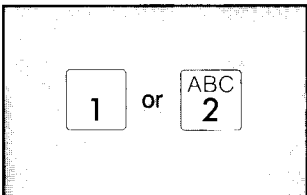

Press "1" to go into the announced feature or press "2" to proceed to another feature.

- 1 Call your unit.
- 2 Dial your code number during the OGM.
- 3 The unit announces the number of recorded messages.

- 5 seconds after you have used each function, the unit will repeat Voice Instruction from the beginning.

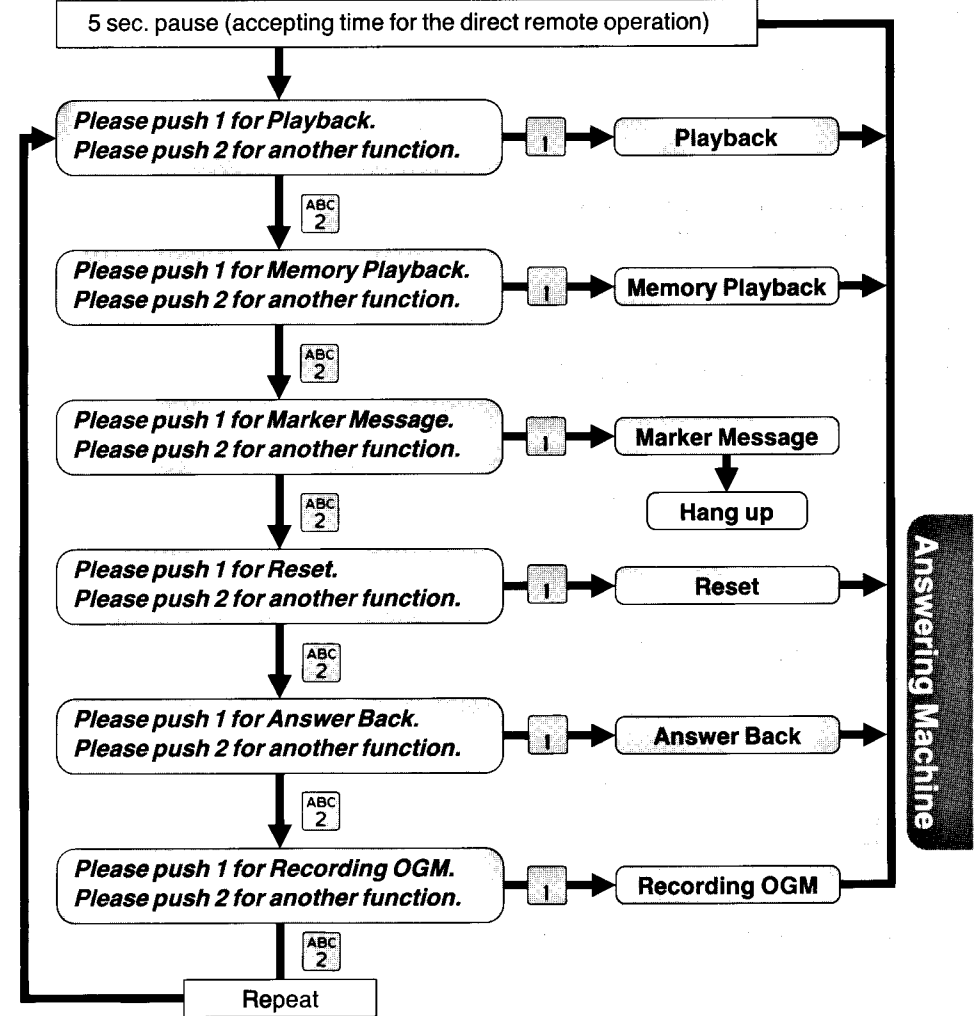

■ Refer to "Setting the remote code" on pages 19 and 20.

■ Refer to "TOLL SAVER" on page 15.

Voice Menu (cont.)

Playback

The unit rewinds the tape and play back all the recorded messages.

- After the last message, the voice will say, "End of final message".
- If you want to operate in succession, wait for 5 seconds. The unit will re-start Voice Menu from the beginning.

Memory Playback

The unit plays back the newly recorded messages.

Marker Message

You can leave a message on the ICM tape.

- 1) Start to talk right after "Marker Message" is announced.
- 2) When finished, hang up.

Reset

The unit rewinds the tape to the beginning.

Answer Back

You can turn on the built-in speaker to screen any sound in the room where the unit is installed. Any one in the room is also able to hear your voice. You can screen for 30 seconds.

Recording OGM

You can re-record the OGM remotely. The unit announces; "Please push 7 to start recording OGM one. Please push 8 to start recording OGM two. Please push 9 to end".

- 1) Press "7".
Short beeps will be heard continuously until the OGM tape has reset followed by a long beep.
- 2) Speak clearly and loudly after the long beep.
- 3) When finish, press "9".
The new OGM will be played back so you can check or amend it. If you pause for over 2 seconds while recording, you will hear 6 beeps and the announcement "Please record your Outgoing Message again". If this happens, repeat from step 1.

To rewind/fast forward/reset during playback

Press "9": The unit stops playback and announces "Please push 1 for back space, 2 for skip, 3 for reset".
Press "1" or "2": The tape will rewind or skip forward for approximately 15 seconds corresponding to playback time.
Press "3": The unit will rewind the tape to the beginning.

You may hang up at any time and the unit will automatically go into the Answer mode. If you hang up without resetting, future Incoming Messages will be recorded after the last message.

Direct Remote Operation

You can also retrieve the recorded messages and control the unit by the direct remote operation regardless of the Voice Menu. If you don't press any button, the unit will enter into the voice menu mode.

Playing back newly-recorded messages (Memory Playback)

1



Call your unit.

2

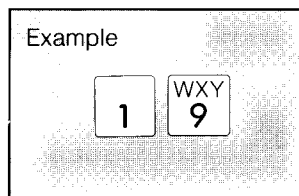

Example

Dial your code number (for example, 19) while the OGM is playing.

The unit announces the number of newly recorded messages.

3

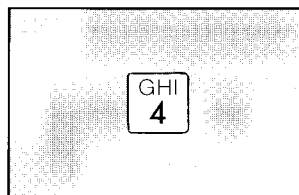

Press "4" right after you hear the synthesized voice telling the number of recorded messages.

"Memory Playback" is announced. The unit will play back the newly recorded messages.

Even during the playback of previously heard messages, you can skip them by pressing "4".

Rewinding/fast forwarding while listening to the messages

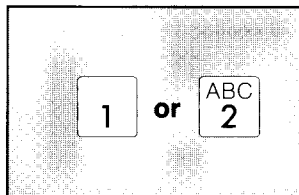

To rewind, press "1".

To fast forward, press "2".

The tape rewinds or fast forwards for approximately 15 seconds corresponding to the playback time.

Direct Remote Operation (cont.)

Resetting the ICM tape for future message

After listening to the recorded messages, you can reset the ICM tape and record new messages from the beginning.



When the recorded messages have been played back or while they are being played:

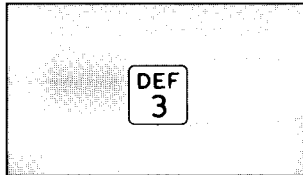

Press "3".

"Reset" will be announced.
The unit will rewind the tape to the beginning.
Future messages will be recorded and the old messages will be lost.

Resetting the tape after you have used Memory Playback

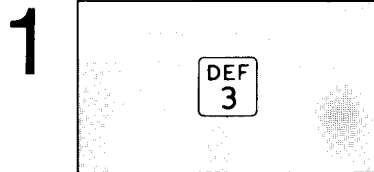

Press "3".

"Reset" will be announced.
The unit will rewind the tape to the beginning of the newly recorded messages and a beep will be heard.

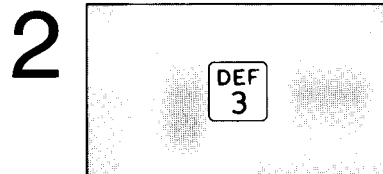

Press "3" again after hearing a beep.

"Reset" will be announced.
The unit will rewind the tape to the beginning of the previously recorded messages.

If you have reset the tape by mistake

Press "2" after hearing a beep (the tape has been reset) then hang up.
"Skip" will be announced.
The tape will advance to the end of the recorded messages.

Recording your message without listening to the OGM

You can record a message directly without listening to the OGM.

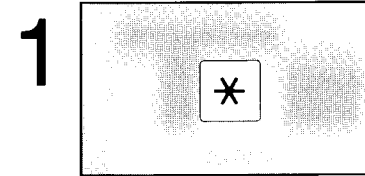

Call your unit, then press "*" while the OGM is playing.
The OGM will stop.



Start speaking after the beep.

Direct Remote Operation (cont.)

Recording a new OGM (Outgoing Message)

You can change the content of your OGM tape from a remote telephone.

Re-recording OGM 1

1



Call your unit.

2

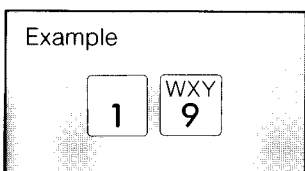

Dial your code number (for example, 19) while the OGM is playing.

The unit announces the number of newly recorded messages.

3

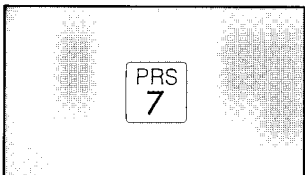

Press "7" to reset the tape.

"Recording OGM one" will be announced. A series of short beeps will be heard continuously until the OGM tape has been reset followed by a long beep.

4



Speak immediately after the long beep.

Do not pause for over 2 seconds. If you hear 6 beeps and the announcement "Please record your Outgoing Message again", start over again from step 3 within 5 seconds.

5

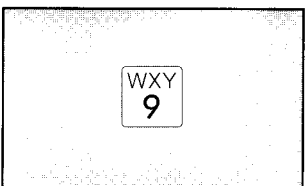

Press "9" when you finished.

The new OGM is played back for you to check or amend.

Re-recording OGM 2

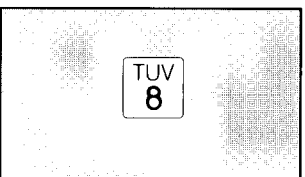

Press "8" instead of "7" at step 3 of the above procedure.

"Recording OGM two" will be announced.

Changing OGM mode (1 or 2)

You can change your OGM mode.

From OGM 1 to OGM 2

1



Call your unit.

2

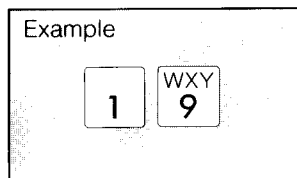

Dial your code number (for example, 19) while the OGM is playing.

The unit announces the number of newly recorded messages.

3

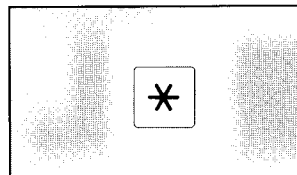

Press "*".

4

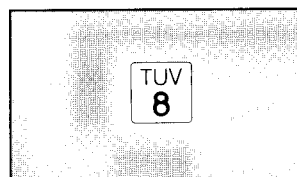

Press "8".

"Two" will be announced.

The unit will play back OGM 2.

From OGM 2 to 1

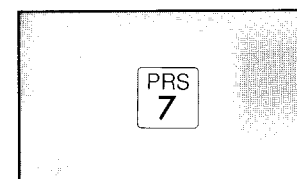

Press "7" instead of "8" at step 4 of the above procedure.

"One" will be announced.

The unit will play back OGM 1.

Direct Remote Operation (cont.)

Turning on the speakerphone (Answer Back)

You can monitor the sound in the room where the unit is installed and speak with anyone in the room where the unit is installed by remotely turning the speakerphone.



1



Call your unit.

2

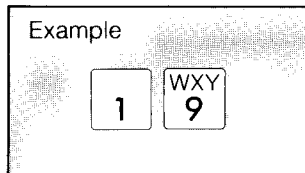

Dial your code number (for example, 19) while the OGM is playing.

The unit announces the number of newly recorded messages.

3

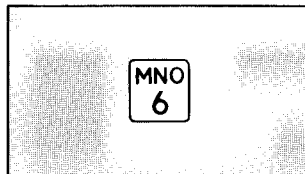

Press "6".

"Answer Back" will be announced.
The speakerphone of the unit will be turned on for 30 seconds.

- If you want to talk to the other party in the room:
Inform the party to lift the handset or press the SP-PHONE button.
- If the Volume Control of the unit has been lowered, the party may not be able to hear your paging from the built-in speaker.
- If no one in the room lifts the handset or press the SP-PHONE button, a beep will be heard after 30 seconds.
- To continue, press "6" again within 5 seconds of hearing a beep.
After 5 seconds of hearing a beep, the unit will enter the Voice Menu mode.

Setting/canceling the answer mode remotely

You can easily set or cancel the answer mode from a remote telephone.



To set the answer mode



Call your unit and let the telephone ring 15 times.

The unit will answer, and the OGM will be heard, then hang up.

The unit will be ready to answer the next phone call.

To cancel the answer mode

1



Call your unit.

2

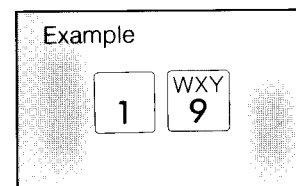

Dial your code number (for example, 19) while the OGM is playing.

The unit announces the number of newly recorded messages.

3

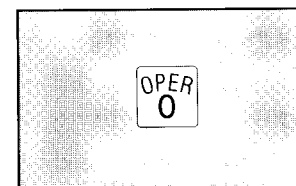

Press "0".





The unit will be turned off and will not answer any calls.

Transferring the ICM

If a telephone number is stored into the transfer station and the unit is set to the transfer mode, each time an ICM is recorded, the unit will automatically dial the number to which the ICM is to be transferred.

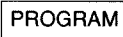
Initial programming for transferring ICM

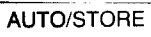
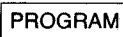

Before storing the telephone number into the transfer memory station, program as follows.

- 1 Press      
- 2 To transfer the ICM to your desired telephone, store the transferred telephone number into the transfer memory station. (See page 55.)

Recording the transfer OGM

When the called party answers, the unit plays the transfer OGM to inform you that an ICM has been recorded. Before using this ICM transfer feature, record the transfer OGM. Transfer OGM's recording time is limited to 30 seconds.

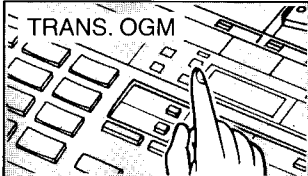
Make sure the POWER indicator lights.

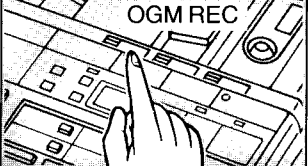
- 1  Press the TRANS. OGM button.
The TRANSFER indicator flashes at first, then it will switch to a steady light after the unit finishes rewinding the OGM tape.
- 2  Press the OGM REC button until a long beep is heard, then release it.
The IN USE indicator flashes.
- 3  "Hello, this is Alice. I'm going to..."
Start recording at once.
- 4  Press the OGM REC button again when you finished recording.
The unit resets the OGM tape, and it will be ready to answer incoming calls.

Checking your transfer OGM

- 1 Press the TRANS. OGM button.
The TRANSFER indicator flashes at first, then it will switch to a steady light after the unit finishes rewinding the OGM tape.
- 2 Press the OGM PLAY button.
Press the OGM PLAY button again if you want to stop the operation halfway.

Sample of transfer OGM

"Hello. This is Dick Smith. I'm going to visit you today. While I'm away, if somebody calls me, the answering machine will get the messages, so could you tell me if my machine calls you before my arrival? Thank you."

NOTE:

- If the initial programming is set for pager mode (See NOTE on page 57.), the transfer OGM is not played back, so the transfer OGM recording is not necessary.
- Speak loudly and clearly right after the beep, about 20 cm (8") away from the microphone (MIC).
Do not pause for over 2 seconds.
If you hear 6 beeps and the announcement "Please record your Outgoing Message again", start over again from step 2 after the unit stops rewinding.

Transferring the ICM (cont.)

Storing the telephone number into the transfer memory station

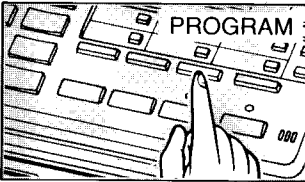
- 

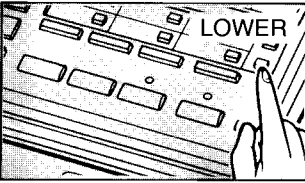
1 Press the PROGRAM button.
The MUTE/STORE indicator lights.
- 

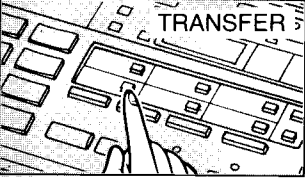
2 Press the LOWER button.
The MUTE/STORE indicator flashes.
- 

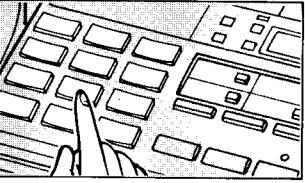
3 Press the TRANSFER button.
The MUTE/STORE indicator goes out.
- 

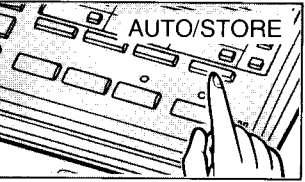
4 Dial the telephone number (up to 30 digits).
- 

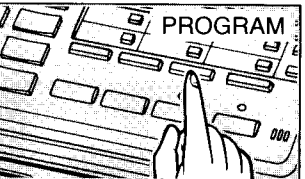
5 Press the AUTO/STORE button.
The MUTE/STORE indicator lights.
- 

6 Press the PROGRAM button.
The MUTE/STORE indicator goes out.

Instead of storing the telephone number into the transfer memory station, you can store a pager's number. See NOTE on page 57.

Setting the transfer mode

Make sure the transfer number is stored and the POWER indicator lights.

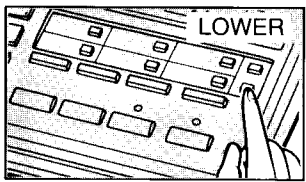
- 

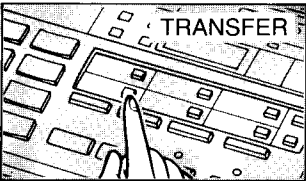
1 Press the LOWER button.
- 

2 Press the TRANSFER button.
The TRANSFER indicator lights.

To cancel

Repeat steps 1 and 2. The TRANSFER indicator is off.

Transferring the ICM (cont.)

Listening to the transferred ICM

Each time an Incoming message is recorded, the unit will automatically dial the phone number to which the Incoming Message is transferred.



1 Lift the handset when the telephone rings.
You will hear your transfer OGM.

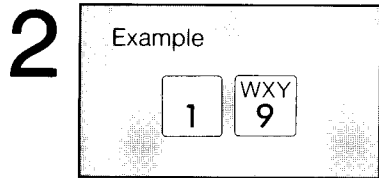

2 Dial your code number (for example, 19) while the transfer OGM is playing.

The unit announces the number of newly recorded messages.

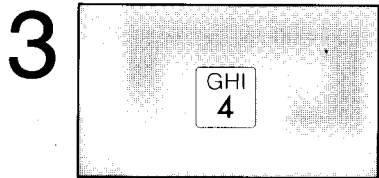

3 Press "4" right after you hear the synthesized voice telling the number of recorded message.

"Memory Playback" will be heard.
The unit will play back the newly recorded message at once.

NOTE:

- If you cannot dial your code number during the OGM, hang up. Your KX-T2470 will dial again after 1 minute.
- If the transferred number is busy, the unit will redial up to 15 times within a 10-minute period.
- If no one answers, the line will be terminated after 1 minute. The unit will dial again after 1 minute.
- If you have a pager, the transfer feature can be used when an Incoming Message is recorded by programming the pager number into the transfer memory station. Depending on the system of the pager you use, the unit may call the pager several times. In this case, please re-program your unit as follows to avoid redialing.

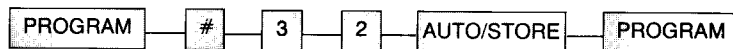

Storing a transfer number from a remote phone

If you forget to program the transfer number to which the ICM is to be transferred, the number can be programmed from a remote phone.

- 1** Call your unit and dial the Code number during the OGM.
- 2** Press as follows, immediately after you hear the beeps indicating the number of newly recorded messages.

For the unit at home;



For the unit behind PBX system;

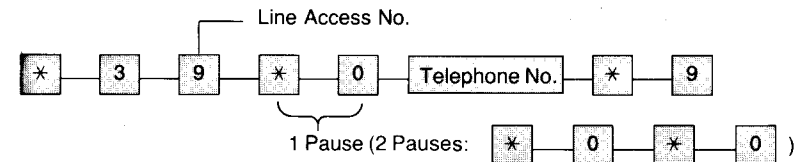

To confirm

Repeat storing procedure.

Refer to "Confirming a stored number" on page 30.

To set the transfer mode immediately after storing the telephone number

Within 10 seconds after storage, press "*" and "1" in sequence.

Setting the transfer mode remotely

You can set or cancel the transfer mode from a remote touch tone phone.

After calling your unit and entering the code number during the OGM:

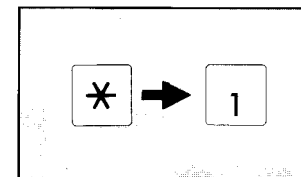

Press "*" right after you hear the announcement indicating the number of the recorded messages, then press "1".

If a telephone number is not stored into the transfer memory station, 6 beeps will be heard. In this case, store the telephone number. (Refer to storing procedure on this page.)

To cancel

Press "2" instead of pressing "1" in the above procedure.

Other Features

Recording a personal messages (Message Memo)

Anyone may record a message memo at home on the tape. It will be heard by anyone retrieving messages from a remote phone.

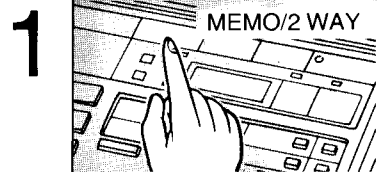

Press the MEMO/2 WAY button until a beep sounds.

The IN USE indicator lights.
The number of messages on the display will increase by one.



Start recording at once.

Speak loudly and clearly right after the beep, about 20 cm (8") away from the microphone (MIC).

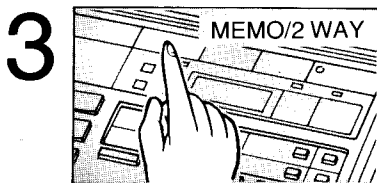

Press the MEMO/2 WAY button again when you finished recording.

The IN USE indicator goes out and the ANSWER indicator will flash to show that your message was recorded, and the unit will be ready to answer incoming calls.

- The message memo will be played back with other Incoming Messages by pressing the PLAYBACK/PAUSE button.

Recording a conversation (2-Way Recording)

This unit is capable of recording a two-way conversation. When a conversation is being recorded, a beep will sound every 15 seconds in order to notify the caller that he/she is being recorded.

In order to remove the beep, you must first refer to the information below.

IMPORTANT

CONSULT YOUR LOCAL PUBLIC UTILITY AGENCY BEFORE DEFEATING THE RECORDING BEEP TONE—MANY STATES HAVE IMPOSED REGULATIONS ON THE MANNER IN WHICH TWO-WAY TELEPHONE CONVERSATIONS MAY BE RECORDED.

Programming 2-Way beep

Press the buttons as follows:

To remove the beep:

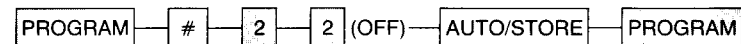

To set the beep:

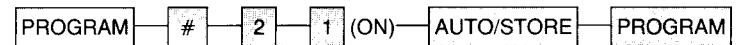

Recording a conversation

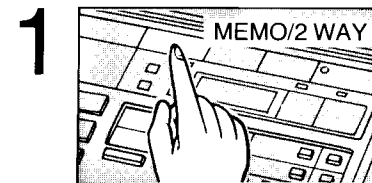

Press the MEMO/2 WAY button until a beep sounds while speaking to the other party.

The IN USE and the ANSWER indicators light.

The number of messages on the display increases by one.

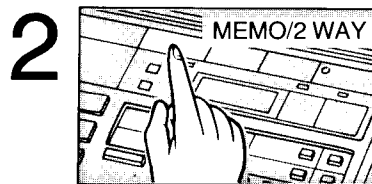

Press the MEMO/2 WAY button again when you finished recording.

The IN USE indicator goes out and the ANSWER indicator will flash to show that the conversation was recorded, and the unit will be ready to answer incoming calls.

- The recorded conversation can be played back with other Incoming Messages by pressing the PLAYBACK/PAUSE button.

Other Features (cont.)

Screening incoming calls

While an Incoming Message is being recorded, you can screen it. Then you may choose to lift the telephone handset or press the SP-PHONE button and speak to the caller.

1

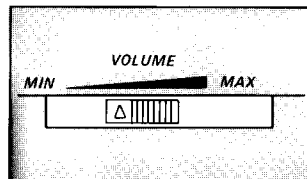

Adjust the VOLUME control.

2



If you want to talk to the caller during recording of the ICM, lift the handset or press the SP-PHONE button and speak to the caller.

The unit will automatically stop recording and will be ready to answer the next telephone call. Even when the handset of another telephone that is connected on the same line lifted, the unit will stop recording. If the ICM tape does not stop, press the hookswitch for about 1 second.

Erasing the recorded messages

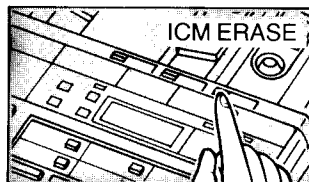

Press the ICM ERASE button until a beep sounds.

The unit erases the recorded messages while the tape is rewinding. To stop erasing, press the ICM ERASE button again.

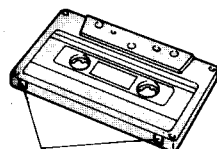

Tabs

The tape can be erased even if the record-prevention (knock-out) tabs have been removed.

General Information

Liquid Crystal Display	63
Announcement by the Unit	64
Troubleshooting Guide	65
Wall Mounting	67
Referencia Rápida (Spanish Quick Reference)	69~79
Accessory Order Information	80
Maintenance	82
Precaution	84
Important Information	85

Liquid Crystal Display

Display	Description
(Current Time) AM 10:30	The POWER ON/OFF button is set to off. (The POWER indicator is off.)
(Tape Timer) OGM 1 0 25	Outgoing Message is being recorded or played back. Example: "25" means 25 seconds elapsed.
(Message Counter) MESSAGE 12	The recording time is set to "1 minute" or "VOX" mode. The display will show the number of recorded messages.
(Call Counter) CALL 18	The recording time is set to "Announce only" mode. The display shows the number of calls received.
(Error) E r r	<ul style="list-style-type: none"> •The OGM tape is broken or not inserted. •There is more than a 2-second pause while recording the OGM.
(Flashing) AM 12:00	<ul style="list-style-type: none"> •The AC adaptor has just plugged into the unit at initial use. •When power is restored after a power interruption.
h	When confirming a stored telephone number including "*" with voice memo check.
#	When confirming a stored telephone number including "#" with voice memo check.
P	When confirming a stored telephone number including "PAUSE" with voice memo check.
F	When confirming a stored telephone number including "FLASH" with voice memo check.

Announcement by the Unit

Announcement	Description
Number of messages received twelve (12 messages are recorded.)	<ul style="list-style-type: none"> •When you press the PLAYBACK/PAUSE button or the NEW MESSAGE button. •When you press your remote code number on a remote phone to play back the recorded messages.
End of final message	All the recorded messages have been played back.
End of tape	The ICM tape is full.
Please record your Outgoing Message again	You pause for over 2 seconds while recording your OGM.
Monday seven o'clock AM	<p>Display shows</p> <p>AM 7:00</p> <p>When you press the TIME DAY CHECK.</p>

- While operating your unit from a remote phone, you can hear the synthesized voice instructions. (Refer to pages 43, 44 and 45.)

Troubleshooting Guide

Problem	Cause & Remedy
The unit does not work when I press any button.	Plug in the AC adaptor then press the POWER ON/OFF button to turn on the unit.
The unit has been set to the answer mode, but no Incoming Messages are recorded.	<ul style="list-style-type: none"> •The cassette tape is cut or is not inserted. Insert the tape or replace it with a new one. •The OGM is recorded improperly. Record a new OGM. •The recording time mode is set to "Announce only" (See page 17 and 18.).
The unit does not function. However, 6 beeps sound and the display shows "Err".	<ul style="list-style-type: none"> •The cassette tape might be broken. Replace it with a new one. •Clean the heads. (See page 82.)
While recording an OGM, 6 beeps and the announcement "Please record your Outgoing Message again" are heard and the display shows "Err".	Re-record your OGM. Speak clearly and loudly, and do not pause for over 2 seconds while recording.
When the cassette tape is played back, the sound level is low, even if the VOLUME control is turned up fully.	Clean the heads. (See page 82.)
I have played back all the recorded messages and I want to record the next phone call after the last previously recorded messages.	<ul style="list-style-type: none"> •Wait for 7 seconds. The unit will be ready to record the next phone call. •In case of remote operation, just hang up.
Some ICMs have not been recorded up to their end.	Set the CPC mode to "B". (See pages 13 and 14.)
ICM transfer cannot be done.	Telephone number has not been stored into the transfer memory station. Make sure that the transfer mode is set. (See pages 56 and 58.)

Problem	Cause & Remedy
I press the button of a remote telephone, but the unit does not respond.	<ul style="list-style-type: none"> •Make sure that you are entering your correct remote code number. •Record the OGM in a quiet place. •In some areas, a remote touch tone phone may not function due to telephone line conditions such as line noise, echo, etc. •The unit may not respond if a touch tone telephone produces tones that are too short to activate the unit. When you press any button, press firmly.
The unit does not announce the time and day when I press the TIME DAY CHECK button.	<ul style="list-style-type: none"> •Set the time and day again. (See pages 11 and 12.) •Adjust the volume control.
My pager rings repeatedly. (When the pager's number is stored as the transfer number.)	See NOTE on page 57.

Wall Mounting

The unit can be mounted on a wall phone plate. If you do not have a modular wall phone plate installed, we recommend that you consult with your telephone company or an installer.

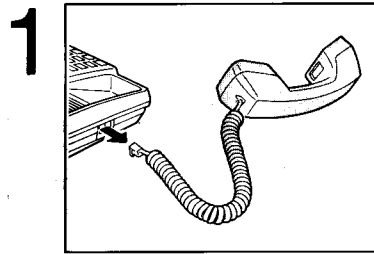

Unplug the handset cord from the unit.

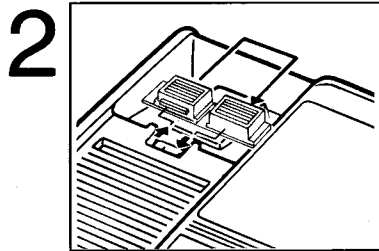

Turn around the handset hook.

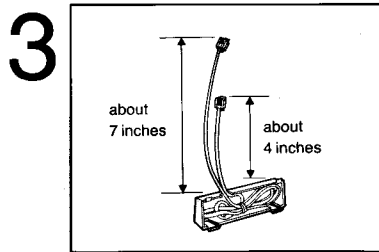

Insert the telephone cord as shown.

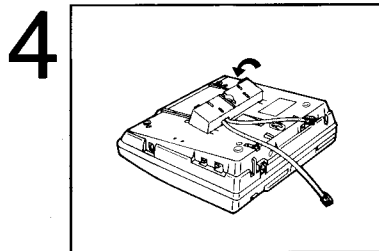

Place the wall mount adaptor as shown.

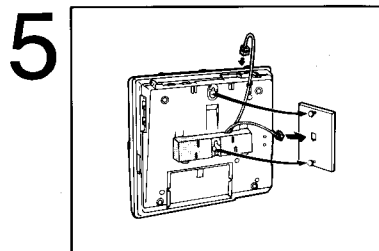

Mount the unit eyelets as shown.

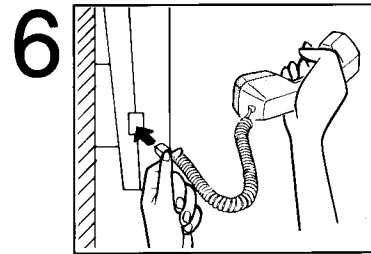

Connect the handset cord to the unit.

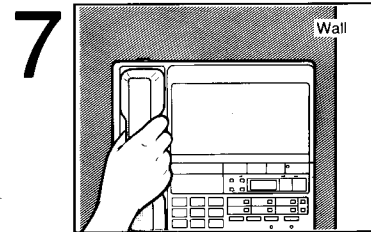

Place the handset as shown.

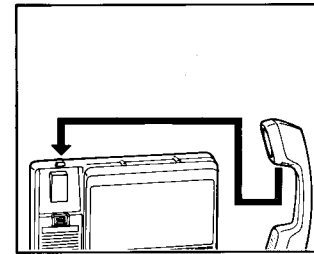

To temporarily place the handset down during a conversation, hook as shown.

Accessory Order Information

- Replacement parts and accessories are available through your local authorized parts distributor.
- For the authorized distributors in your area, call toll free: 1-800-545-2672

Part No.	Description	Comment
KX-J07W KX-J15W KX-J25W	Handset cord	7 feet 15 feet 25 feet (W: white color)
KX-J66	T-adaptor	Parallel connection for single line
KX-C150 KX-C300	OGM tape	
KX-C600 KX-C900	ICM tape	

QUICK REFERENCE CARD

FOR TONE REMOTE CONTROL

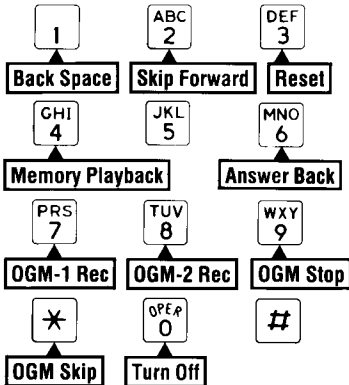

- To set answer mode remotely, call your unit and wait for 15 rings. The unit will answer, then hang up.
- To turn off the unit remotely, press Code No. → press 0 → hang up.

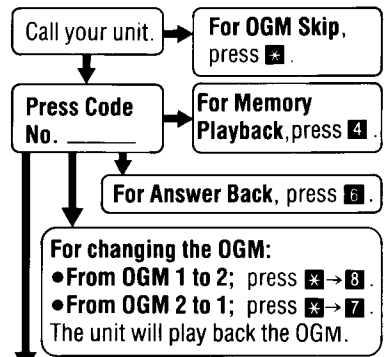

During ICM playback:

- For Back Space, press 1.
- For Skip Forward, press 2.
- For ICM Tape Reset, press 3.
- To save the ICM, hang up after playback.
- To record a Marker Message, speak after the announcement of "Marker Message."

Call your unit. → Press Code No.

Re-recording the OGM

1. Press **7** to re-record OGM 1.
or
Press **8** to re-record OGM 2.
2. Speak after the long beep.
 - Do not pause for over 2 sec.
3. When finished, press **9**.

Storing the Transferred No.

The unit at home

Press ***** → **3** → [A beep] → [Phone No.]
→ ***** → **9**

The unit at office (PBX)

Press ***** → **3** → [A beep] → **9** (access)
→ ***** → **0** → [Phone No.] → ***** → **9**

1 pause (2 pauses ***** → **0** - ***** → **0**)

- The unit will enter into the Voice Menu mode if you don't press any button.

To set the transfer mode:

Press *****, then **1**.

To cancel the transfer mode:

Press *****, then **2**.

Listening to the Transferred ICM

1. Lift the handset when a call arrives.
2. Press **the Code No.** while the transfer OGM is being heard.
 - If the Code No. is not accepted, hang up. The unit will call you again after 1 min.
3. Press **4** for Memory Playback.
 - If you don't press "4", the unit will go into the voice menu. Follow voice instructions.
4. When finished, hang up.

- When you press any button, press firmly.

Maintenance

Because the head and capstan assemblies are in contact with the tape, dirt and residue from the tape can easily adhere to these parts, causing distortion. These parts should be cleaned periodically in the manner described below.

Clean the head surface, pinch roller and capstan with a cotton swab.

If these surfaces are extremely dirty, dampen the cotton swab with alcohol.

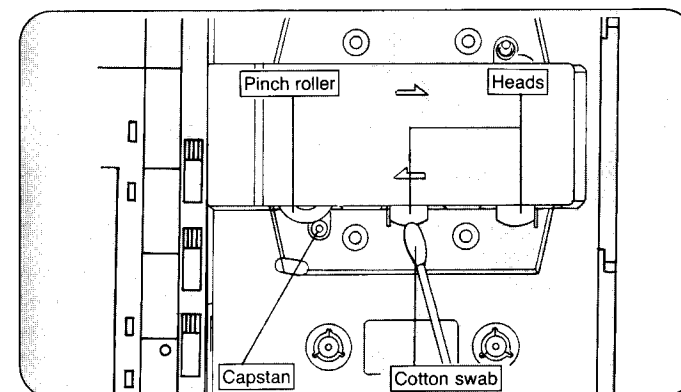

- Do not place magnetic or metal objects, such as a screwdriver, near the head assemblies, as such objects could magnetize the heads.
- Do not oil any part of the unit.

OGM and ICM cassette tapes

- For optimum sound quality and performance, we recommend that you **use side two after six months and replace the tape every year** assuming that the unit answers about ten calls a day.
- Should the cassette tape break or become worn, replace it with a high quality "NORMAL" tape. Use Panasonic (C15 and C30 for OGM, C60 and C90 for ICM), TDK or MAXELL cassette tape. Metal or chrome tape cannot be used.
- Never place a cassette tape near a magnetic source, such as a magnet or a TV set, because it may erase the tape.
- Slack in the tape can be tightened by rotating the tape reel with an instrument like a pencil, as shown.

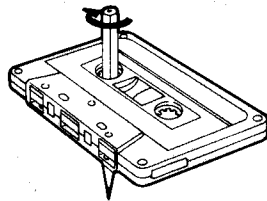

Cassette panel installation

If the panel comes off, replace it by pushing as shown.

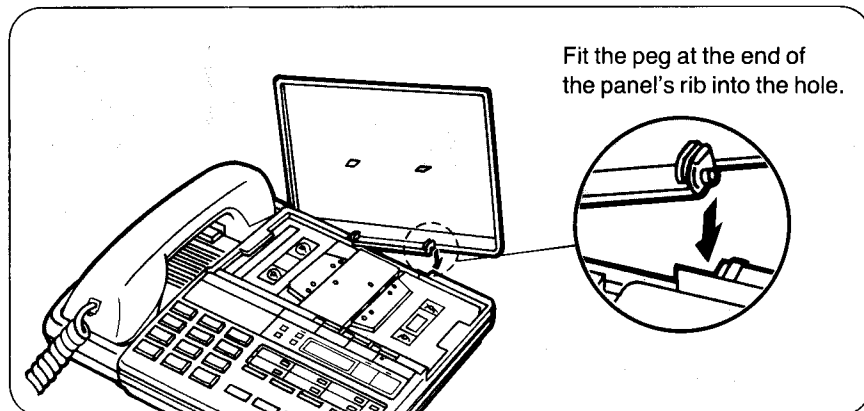

Precaution

Take special care to follow the safety suggestions listed below.

Safety

- 1) Power Source: The unit should be connected to a power supply only of the type described in the operating instructions or as marked on the unit.
- 2) Nonuse Periods: When the unit is not used, turn the power off. When left unused for a long period of time, the unit should be unplugged from the household AC outlet.

If there is any trouble, disconnect the unit from the telephone line and connect a known working phone. If the known working phone operates properly, have your Panasonic phone repaired by one of the specified Panasonic Factory Service Centers. If the known working telephone does not operate properly, consult with your telephone company.

Installations

Environment

- 1) Water and Moisture: Do not use this unit near water—for example, near a bath tub, washbowl, swimming pool, or the like. Damp basements should also be avoided.
- 2) Heat: The unit should be situated away from heat sources such as radiators and the like. It also should not be placed in temperatures less than 41°F (5°C) or greater than 104°F (40°C).

Placement

- 1) Foreign Material: Care should be taken so that objects do not fall into and liquids are not spilled into the unit. Do not subject this unit to excessive smoke, dust, mechanical vibration, or shock.
- 2) Magnetism: The unit should be situated away from equipment or devices that generate a strong magnetic field.
- 3) Stacking: Do not place heavy objects on top of this unit.
- 4) Surface: Place the unit on a flat level surface.

WARNING:

TO PREVENT FIRE OR SHOCK HAZARD, DO NOT EXPOSE THIS PRODUCT TO RAIN OR ANY TYPE OF MOISTURE.

This telephone provides magnetic coupling to hearing aids.

Free Manuals Download Website

<http://myh66.com>

<http://usermanuals.us>

<http://www.somanuals.com>

<http://www.4manuals.cc>

<http://www.manual-lib.com>

<http://www.404manual.com>

<http://www.luxmanual.com>

<http://aubethermostatmanual.com>

Golf course search by state

<http://golfingnear.com>

Email search by domain

<http://emailbydomain.com>

Auto manuals search

<http://auto.somanuals.com>

TV manuals search

<http://tv.somanuals.com>