

# Panasonic

Cordless Phone

Model No. **KX-TC1170ALN**

## Operating Instructions

Preparation

Basic Operation

Advanced Operation

Useful Information



**PLEASE READ BEFORE USE  
AND SAVE.**

Caller ID Compatible

**Charge the battery for about 10 hours before initial use.**

# Before Initial Use

*Thank you for purchasing your new Panasonic cordless telephone.*

## For Australia

When you subscribe to Caller ID services from your telephone operator, this telephone will display the caller's phone number. When available from your telephone operator, this telephone will also display the number of the second call or call waiting.

## For New Zealand

Caller ID, where available, is telephone company service. After subscribing to Caller ID, this phone will display a caller's phone number.





## For your future reference

Serial No. \_\_\_\_\_ Date of purchase \_\_\_\_\_  
 (found on the bottom of the unit)

Name and address of dealer \_\_\_\_\_

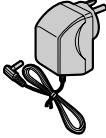
Attach or keep original receipt to assist with any repair under warranty.

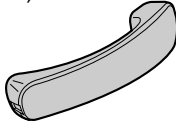
## Accessories (included)

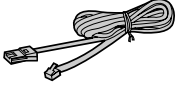
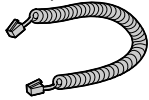
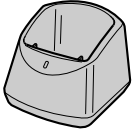
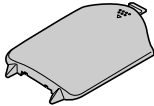
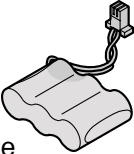
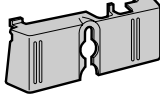
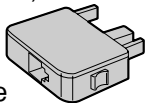
<input type="checkbox"/> AC Adaptor for Base Unit (Model No. KX-TCA1AL) (p. 11)  one	<input type="checkbox"/> AC Adaptor for Charger (Model No. PQLV13AL) (p. 10)  one	<input type="checkbox"/> Base Unit Handset (p. 11)  one	
<input type="checkbox"/> Telephone Line Cord (p. 11) <b>For Australia</b>  one	<input type="checkbox"/> Telephone Line Cord (p. 11) <b>For New Zealand</b>  one	<input type="checkbox"/> Handset Cord (p. 11)  one	<input type="checkbox"/> Charger (p. 10, 12)  one
<input type="checkbox"/> Portable Unit Cover (p. 12)  one	<input type="checkbox"/> Battery (p. 12)  one	<input type="checkbox"/> Wall Mounting Adapter (p. 72)  one	<b>For Australia only</b> <input type="checkbox"/> Telephone Plug (p. 11)  one

To use more than one portable unit, please purchase the optional portable unit KX-TCA391ALN. The charger is included.

# For Best Performance

## Battery Charge

A rechargeable Nickel Cadmium (Ni-Cd) battery powers the portable unit. Charge the battery for about **10 hours** before initial use (p. 12). Make sure the portable unit faces forward as shown.

- **Clean the charge contacts of the portable unit and the charger with a soft, dry cloth once a month. Clean more often if the unit is subject to grease, dust or high humidity.** Otherwise the battery may not charge properly.



## Base Unit Location

Calls are transmitted between the base unit and the portable unit using wireless radio waves. **For maximum distance and noise free operation**, the recommended base unit location is:

Away from electrical appliances such as a TV, personal computer, cellular phone, charging unit.

In a **HIGH and CENTRAL** location with no obstructions such as walls.

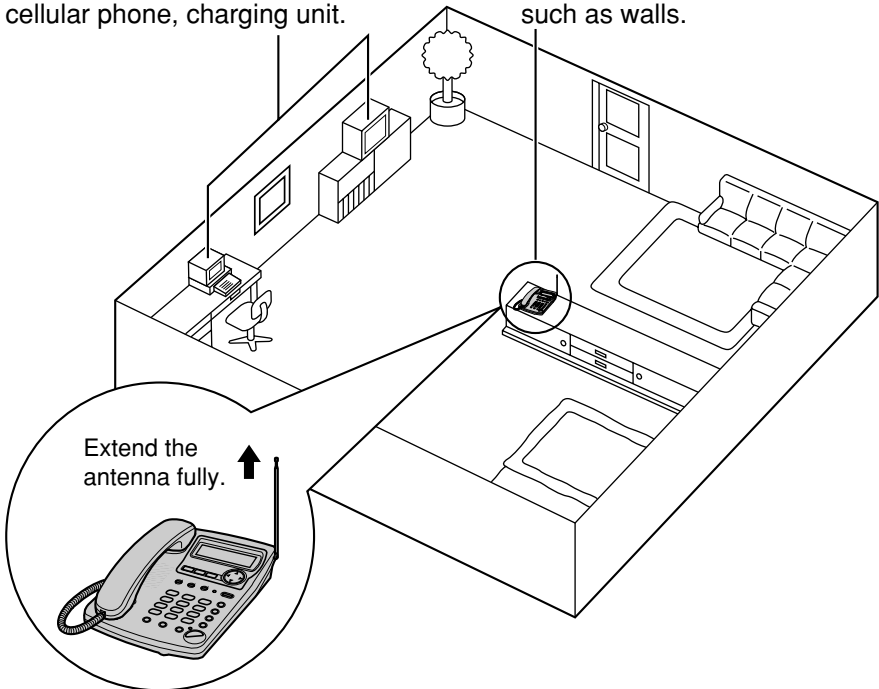

# Contents

---

## Preparation

<b>Location of Controls</b> .....	6
<b>Displays</b> .....	8
<b>Settings</b> .....	10
Connections .....	10
Installing the Battery .....	12
Battery Charge .....	12
Selecting the Ringer Volume <b>Portable Unit Base Unit</b> .....	14
Setting the Time and Date <b>Base Unit</b> .....	16
Setting the LCD Contrast <b>Base Unit</b> .....	18
<b>Programming Summary of Preparations</b> <b>Portable Unit Base Unit</b> .....	19

## Basic Operation

<b>Making Calls</b> <b>Portable Unit Base Unit</b> .....	21
With the Portable Unit.....	21
With the Base Unit.....	23
<b>Answering Calls</b> <b>Portable Unit Base Unit</b> .....	25
With the Portable Unit.....	25
With the Base Unit.....	25
<b>Caller ID Service</b> <b>Portable Unit Base Unit</b> .....	26
<b>Using the Caller List</b> <b>Portable Unit Base Unit</b> .....	28
Viewing the Caller List .....	28
Calling Back from the Caller List .....	32
Editing the Caller's Phone Number .....	33
Storing Caller List Information in the Directory .....	35
Storing Caller List Information in the One-Touch Dialler Memory .....	36
Storing Caller List Information in the Speed Dialler Memory .....	37
Erasing Caller List Information .....	38
<b>Using the Directory</b> <b>Portable Unit</b> .....	40
Storing Names and Numbers in the Directory .....	40
Steps for Entering Names and Symbols.....	42
Finding Items in the Directory .....	44
Dialling from the Directory .....	45
Editing an Item in the Directory.....	46
Erasing an Item from the Directory .....	47
<b>One-Touch Dialler</b> <b>Base Unit</b> .....	48
Storing Phone Numbers in Memory .....	48
Dialling a Stored Number .....	49

<b>Speed Dialler</b> <i>Base Unit</i> .....	50
Storing Phone Numbers in Memory .....	50
Dialling a Stored Number .....	51

## Advanced Operation

<b>Using the Alarm Clock</b> <i>Base Unit</i> .....	52
<b>Dial Lock</b> <i>Base Unit</i> .....	55
<b>Call Restriction</b> <i>Base Unit</i> .....	56
<b>Intercom</b> <i>Portable Unit</i> <i>Base Unit</i> .....	58
Transferring a Call Using the Intercom <i>Portable Unit</i> <i>Base Unit</i> .....	60
<b>Special Features</b> .....	62
How to Use the PAUSE Button (For Analog PBX Line/ Long Distance Service Users) <i>Portable Unit</i> <i>Base Unit</i> .....	62
Call Waiting and Caller ID Compatible (For Australia only) <i>Portable Unit</i> <i>Base Unit</i> .....	62
RECALL Button <i>Portable Unit</i> <i>Base Unit</i> .....	62
Setting the Password <i>Base Unit</i> .....	64
<b>For Optional Multi-Portable Unit Users</b> .....	65
Registering Optional Portable Units <i>Base Unit &amp; Portable Unit</i> .....	66
Intercom Between the Portable Unit(s) and Base Unit <i>Portable Unit</i> <i>Base Unit</i> .....	68
Transferring Calls Using the Intercom <i>Portable Unit</i> <i>Base Unit</i> .....	70
Transferring Calls from One Portable Unit to Another <i>Portable Unit</i> .....	71

## Useful Information

<b>Wall Mounting</b> .....	72
<b>Battery Replacement</b> .....	74
<b>Before Requesting Help</b> .....	75
<b>Safety Instructions</b> .....	79
<b>Important Information</b> .....	81

### Important:

*Portable Unit* : Must be carried out with the portable unit.

*Base Unit* : Must be carried out with the base unit.

*Base Unit & Portable Unit* : Must be carried out by both the base unit and portable unit together.

*Portable Unit* *Base Unit* : Must be carried out separately by the base unit and the portable unit.

# Location of Controls

## Base unit

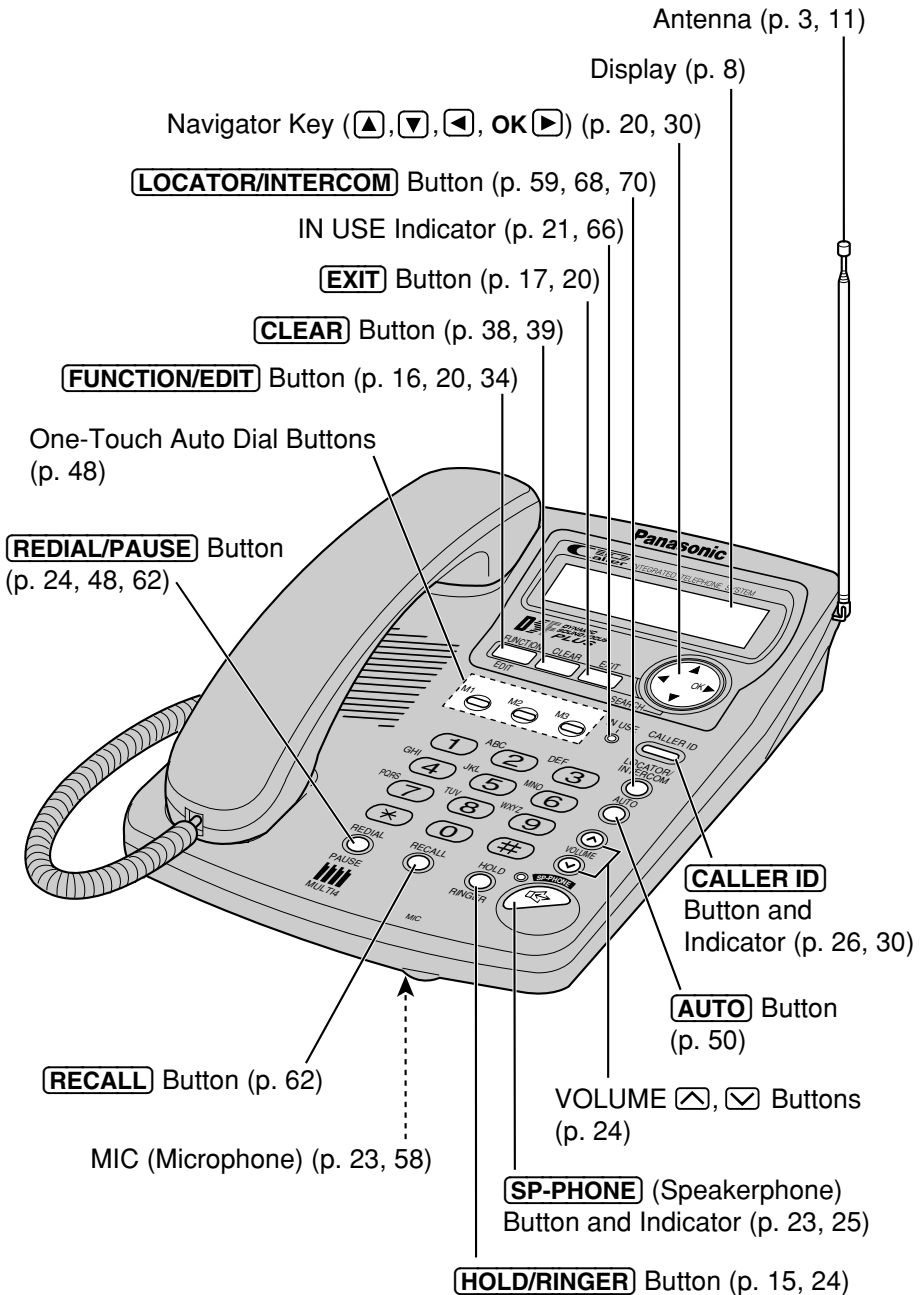

## Portable unit

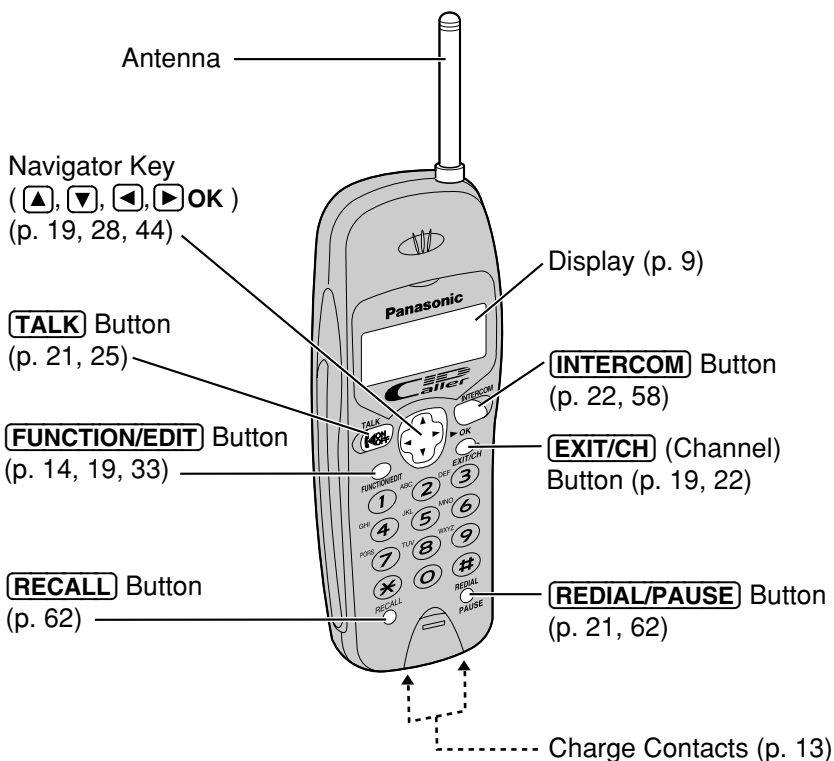

## Charger

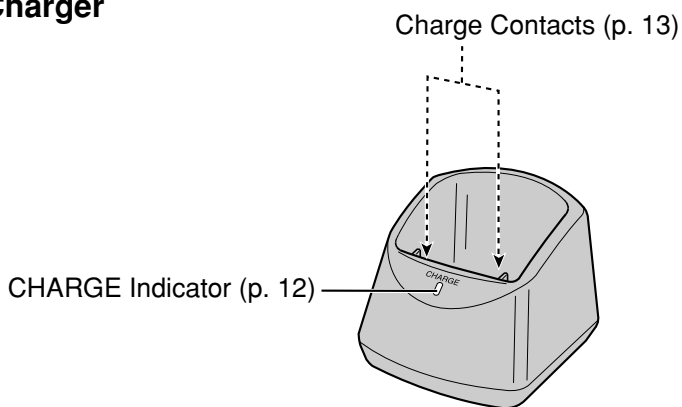

# Displays

## Base unit display

12:00<sup>AM</sup> 1/1

10 NEW CALLS

If the display continuously shows “12:00<sup>AM</sup> 1/1” or “0:00 1/1”, the clock needs adjusting (p. 16).

11:34<sup>AM</sup> 12/25

10 NEW CALLS

In the standby mode, the display shows the current time and date, and the number of new calls.

11:50<sup>AM</sup> 11/24

1-06-35

During a conversation, the display shows the length of the call. (Ex. 1 hour, 6 minutes and 35 seconds.)

11:50<sup>AM</sup> 12/25

RINGER OFF

The base unit ringer volume is off. To turn the ringer on, see page 15.

11:50<sup>AM</sup> 11/24

DIAL LOCKED

The dial lock mode is set. To cancel the mode, see page 56.

11:50<sup>AM</sup> 11/24

CALL RESTRICTED

When the restricted number (0 or 00) is dialled, it is displayed. To cancel the mode, see page 57.

11:34<sup>AM</sup> 12/25

LINE BUSY

While the portable unit is engaged in an outside call, it is displayed.

11:34<sup>AM</sup> 12/25

CALLER-ID BUSY

While the portable unit user is using the Caller List, it is displayed.

11:50<sup>AM</sup> 12/25



The alarm clock is turned on. To cancel the mode, see page 54.

11:50<sup>AM</sup> 12/25

NO ITEM STORED

The Caller List is empty.

11:50<sup>AM</sup> 11/24<sub>NEW</sub>#41 ×3  
0355667788

This is a display from the Caller List.

The display shows:

- the time and date of the last call (Ex. Nov. 24, 11:50 AM),
- the number of the call in the Caller List (Ex. #41),
- the caller information is new and has not been viewed (“NEW” is displayed),
- the number of times called (Ex. 3 times) and
- the caller’s phone number.





## Portable unit display

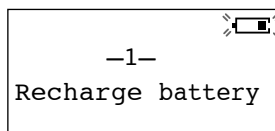

The battery needs to be charged. Place the portable unit on the charger to charge the battery (p. 12).

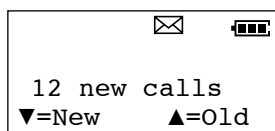

The display will show the number of new calls when ◀ or ▶ OK is pressed.

To search from the most recent call, press ▼ (New key). To search from the oldest call, press ▲ (Old key) (p. 28).

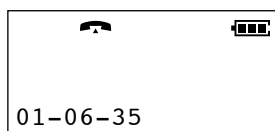

During a conversation, the display shows the length of the call (Ex. 1 hour, 6 minutes and 35 seconds). The battery strength is also displayed (p. 12).

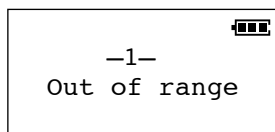

This display will be shown when:

- the portable unit has lost communication with the base unit. Move closer to the base unit, or
- another portable unit is in use.

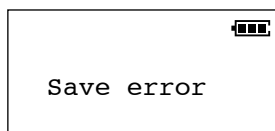

While programming, the portable unit lost communication with the base unit. Move closer to the base unit.

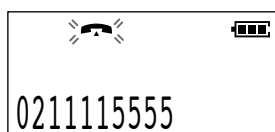

When a call is received, the display shows the caller's phone number after the first ring.

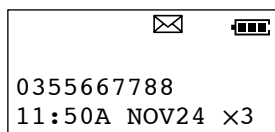

This is information from the Caller List.

The display shows:

- the caller's phone number,
- the time and date of the last call (Ex. Nov. 24, 11:50 AM), and
- the number of times called (Ex. 3 times).

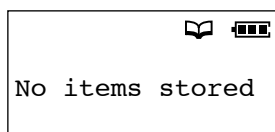

This display will be shown when:

- the Caller List is empty,
- the directory list is empty, or
- there are no stored items in the dialling button you pressed in the directory.

## ➔ Displays

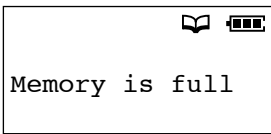

When trying to store an item or Caller List information in the directory, the directory memory is full (p. 35, 41).

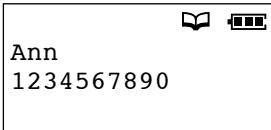

This is a name from the directory. The stored name and phone number are displayed.

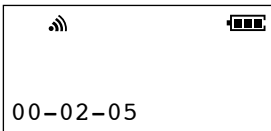

The length of the intercom call between the portable unit and base unit is displayed (Ex. 2 minutes 5 seconds).

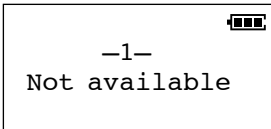

**TALK** was pressed while the base unit was in use.

## Settings

### Connections

#### Charger

To Power Outlet  
(AC 230 V–240 V, 50 Hz)

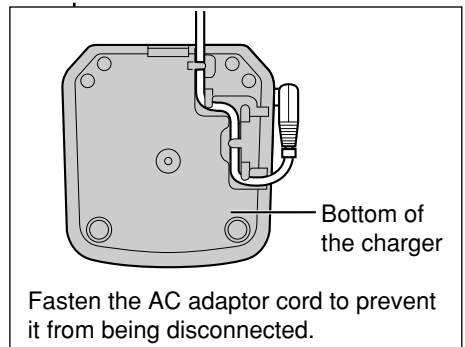
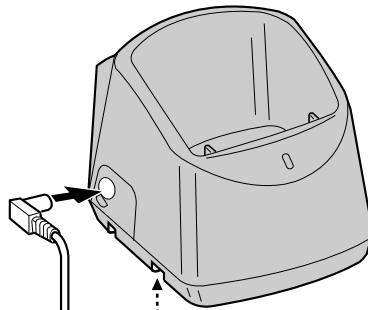
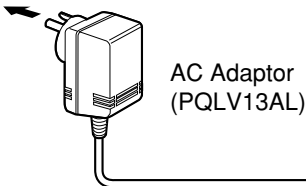

- USE ONLY WITH Panasonic AC ADAPTOR PQLV13AL.
- The AC adaptor must remain connected at all times.  
(It is normal for the adaptor to feel warm during use.)



## Base unit

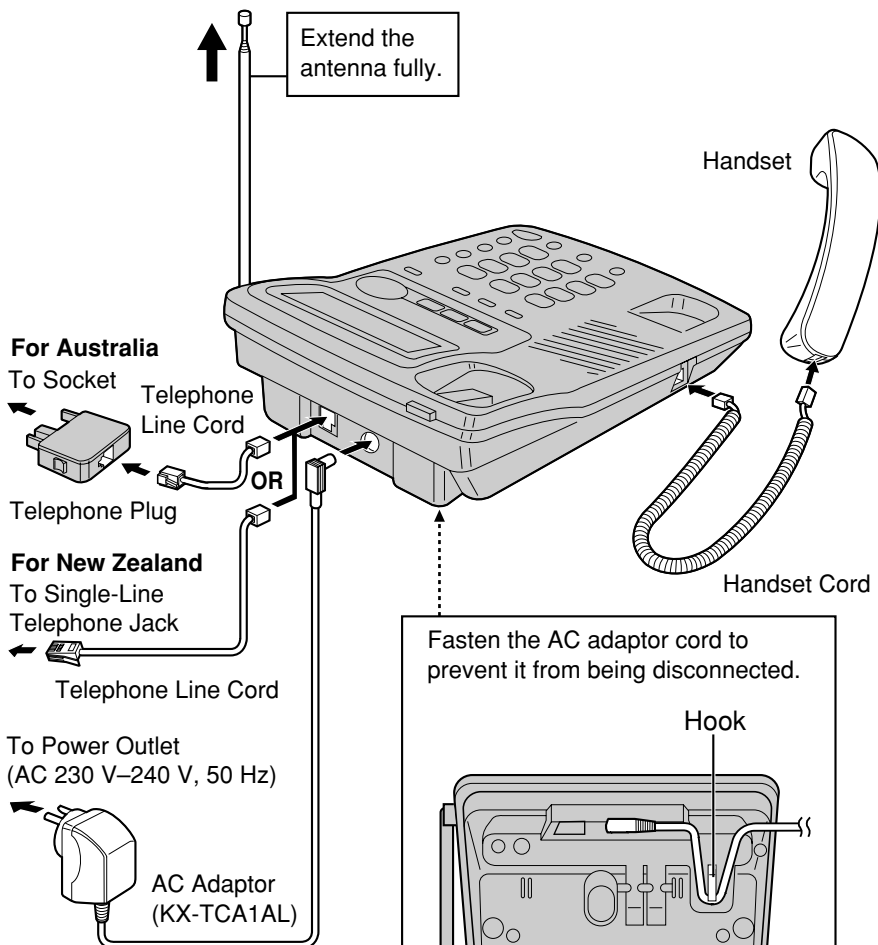

- USE ONLY WITH Panasonic AC ADAPTOR KX-TCA1AL.
- The AC adaptor must remain connected at all times. (It is normal for the adaptor to feel warm during use.)
- Use only a Panasonic Handset for the KX-TC1170ALN.
- During a power failure, this unit functions only as a regular telephone.
- If your unit is connected to a PBX which does not support Caller ID services, you cannot access those services.
- When more than one unit is used, the units may interfere with each other. To prevent or reduce interference, please leave ample space between the base units.
- The unit is not designed to be used with rotary (pulse dialling) services.

# Installing the Battery

Install the battery and close the portable unit cover, locking it into place.

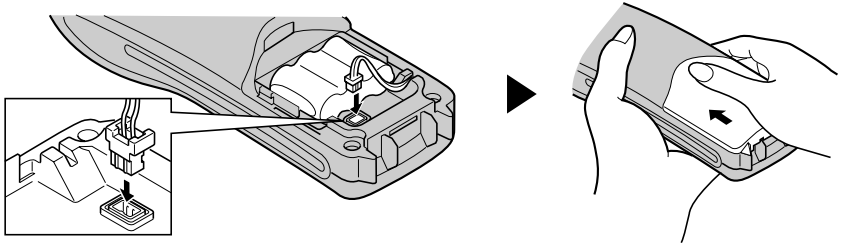

# Battery Charge

Place the portable unit on the charger and charge for about **10 hours** before initial use.

- Make sure that the confirmation tone sounds when the portable unit is placed on the charger.
- The CHARGE indicator lights.
- The portable unit number is displayed.

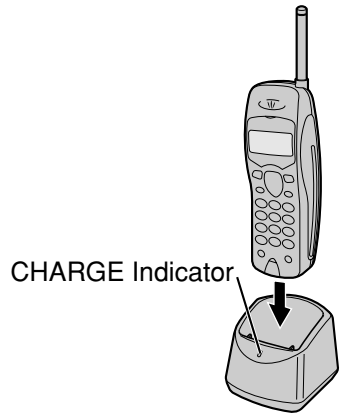
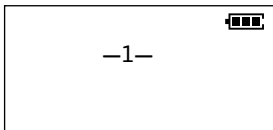

# Battery strength

You can check the preset battery strength on the display.

The battery strength is as shown in the chart below.

Display prompt	Battery strength
	Fully charged
	Medium
	Low
(flashing)	Needs to be recharged.



## Recharge

Recharge the battery when:

- “Recharge battery” is displayed,
- “” flashes on the display, or
- the portable unit beeps intermittently while it is in use.

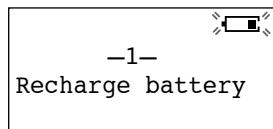

- If you DO NOT recharge the battery for more than 30 minutes, the display will keep indicating “Recharge battery” and/or “” will continue to flash.
- To fully recharge the battery, the portable unit should be left on the charger for 10 hours.

## Battery information

After your Panasonic battery is fully charged (p. 12):

Operation	Approx. battery life
While in use (TALK)	8 hours
While not in use (Standby)	20 days

- Battery life may be shortened depending on usage conditions, such as viewing the Caller ID Caller List or directory items and ambient temperature.
- **Clean the charge contacts of the portable unit and the charger with a soft, dry cloth once a month. Clean more often if the unit is subject to grease, dust or high humidity.** Otherwise the battery may not charge properly.
- If the battery is fully charged, you do not have to place the portable unit on the charger until “Recharge battery” is displayed and/or “” flashes. This will maximize the battery life.
- The battery cannot be overcharged.

## Portable unit standby mode

(The portable unit is off the charger.)

The portable unit goes into the standby mode after you finish using the portable unit (making/answering a call, viewing the Caller List or directory items etc.). The display is blank, but the portable unit can receive calls. The battery life is conserved in this mode.

## Selecting the Ringer Volume **Portable Unit** **Base Unit**

You can set the base unit and portable unit ringer volumes to HIGH, LOW or OFF. If set to OFF, the base unit and portable unit will not ring. Your phone comes from the factory set to HIGH.

### With the portable unit

Make sure that the portable unit is in the standby mode.

1 Press **FUNCTION/EDIT** on the portable unit.

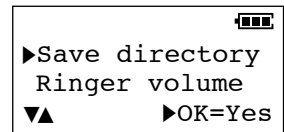

2 Press **▼** or **▲** repeatedly until the arrow points to "Ringer volume". Then press **▶ OK** (Yes key).

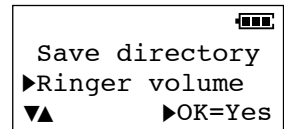

3 Press **▼** or **▲** to select the desired volume.

- The selected volume is displayed and rings.
- **To turn the ringer OFF**, press and hold **▼** until 2 beeps sound.
- The portable unit will return to the standby mode.

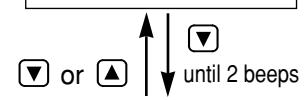
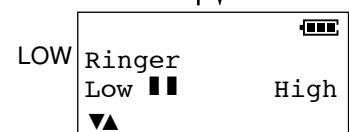
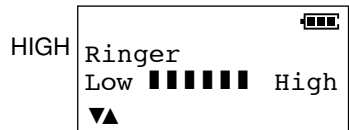

**To turn the ringer ON**, press **▼** or **▲** in step 3.

• The ringer will sound at the LOW level.

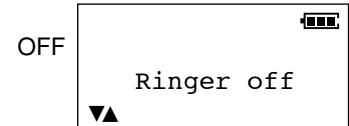



## With the base unit

Make sure that the base unit and portable unit are in the standby mode.

- To select HIGH (preset) or LOW, press **HOLD/RINGER**.

(Each time you press the button, the ringer volume will change.)

— “□” is displayed for about 5 seconds.

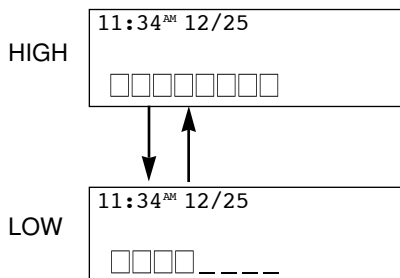

- To turn the ringer OFF, press **HOLD/RINGER** until 2 beeps sound.

— “RINGER OFF” is displayed.

- To turn the ringer ON, press **HOLD/RINGER**.

The ringer will sound at the HIGH level and “□” is displayed for about 5 seconds.

## Setting the Time and Date **Base Unit**

You can select AM/PM or 24-hour clock by programming.

**Make sure that the base unit and portable unit are in the standby mode.**

**1** Press **FUNCTION/EDIT** on the base unit.

12:00<sup>AM</sup> 1/1

SAVE AUTO# ?

**2** Press **▼** or **▲** repeatedly until “SET CLOCK ?” is displayed.

12:00<sup>AM</sup> 1/1

SET CLOCK ?

**3** Press **OK** **▶**.

12:00<sup>AM</sup> 01/01

2000

ENTER TIME

**4** Enter the current time (hour and minute) by using a 4-digit number.  
(Ex. To set 9:30, enter “0930”.)

09:30<sup>AM</sup> 01/01

2000

ENTER TIME

- For AM/PM setting: Enter numbers between 0100 and 1259.  
For 24-hour clock: Enter numbers between 0000 and 2359.

**5** Press **OK** **▶**.

09:30<sup>AM</sup> 01/01

2000

#=AM/PM

- If numbers between 0000 and 0059, or 1300 and 2359 are entered, the time will automatically be set using the 24-hour clock. Skip the steps 6 and 7 and go to the step 8.

**6** Press **#** to select “AM” or “PM” or 24-hour clock.  
(Ex. You select “PM”.)

09:30<sup>PM</sup> 01/01

2000

#=AM/PM

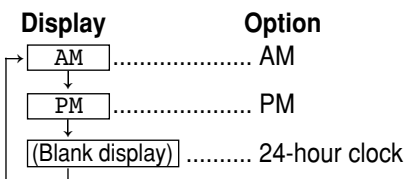

- Each time you press **#**, the selection will change on the display.





7 Press **OK**

```
09:30PM 01/01
2000
ENTER MONTH/DATE
```

8 Enter the current month and day by using a 4-digit number.  
(Ex. To set Dec. 27, enter "1227".)

```
09:30PM 12/27
2000
ENTER MONTH/DATE
```

9 Press **OK**

```
09:30PM 12/27
2000
ENTER YEAR
```

10 Enter the current year by using a 4-digit number.  
(Ex. To set the year 2001, enter "2001".)

```
09:30PM 12/27
2001
ENTER YEAR
```

11 Press **OK**

- A beep sounds.
- The clock starts working.
- To return to the standby mode, press **EXIT**.

```
9:30PM 12/27

SET CLOCK ?
```

- You can go back to the previous display by pressing , when setting the time and date.
- If 6 beeps sound when entering the time and date, a wrong number was entered. Enter the correct time and date.

If a power failure occurs or the AC adapter is disconnected from the base unit for more than about 30 minutes, the time and date will be shown as "12:00<sup>AM</sup> 1/1" or "0:00 1/1". Readjust the date/time.

#### For Caller ID service users (p. 26)

- The Caller ID information will re-set the clock after the first ring if the adjusted time and/or date is incorrect. However, if the time has not previously been set, the Caller ID information will not adjust the clock.
- The Caller ID information will automatically adjust the clock for daylight saving time.

### Setting the LCD Contrast **Base Unit**

You can select the LCD contrast level from 1 to 4 by programming. Your phone comes from the factory set to 3.

**Make sure that the base unit and portable unit are in the standby mode.**

1 Press **FUNCTION/EDIT** on the base unit.

11:34<sup>AM</sup> 12/25

SAVE AUTO# ?

2 Press **▼** or **▲** repeatedly until "LCD CONTRAST ?" is displayed.

11:34<sup>AM</sup> 12/25

LCD CONTRAST ?

3 Press **OK** **▶**.

- The current setting is displayed.

11:34<sup>AM</sup> 12/25

□□□\_

4 Press **▼** or **▲** to select the desired LCD contrast level.

- Each time you press **▼** or **▲**, the level will change on the display.

5 Press **OK** **▶**.

- A beep sounds.
- To return to the standby mode, press **EXIT**.

- You can exit the programming mode any time by pressing **EXIT**.

# Programming Summary of Preparations

Portable Unit Base Unit



## With the portable unit

You can program the following function items **using the portable unit near the base unit**. The display shows the programming instructions. See the corresponding pages for function details.

**Make sure that the base unit and portable unit are in the standby mode.**

Press **FUNCTION/EDIT** on the portable unit.



<Function menu>\*

▶Save directory..... To use the directory (p. 41).  
Ringer volume..... To select the ringer volume (p. 14).  
Program

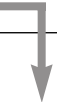

Press **▶ OK**.

<Function menu>\*

▶Set recall time..... To select the recall time (p. 62).  
Unit option..... To register each optional portable units (p. 66).

## During programming

\*To select a desired function item, press **▼** or **▲** repeatedly until the arrow points to the item. Then press **▶ OK** to go to the next step.

- You can exit the programming mode any time by pressing **EXIT/CH**.
- If you do not press any buttons for 60 seconds, the unit will return to the standby mode.

# ➔ Programming Summary of Preparations

## With the base unit

You can program the following function items **using the base unit**. See the corresponding pages for function details.

**Make sure that the base unit and portable unit are in the standby mode.**

Press **FUNCTION/EDIT** on the base unit.

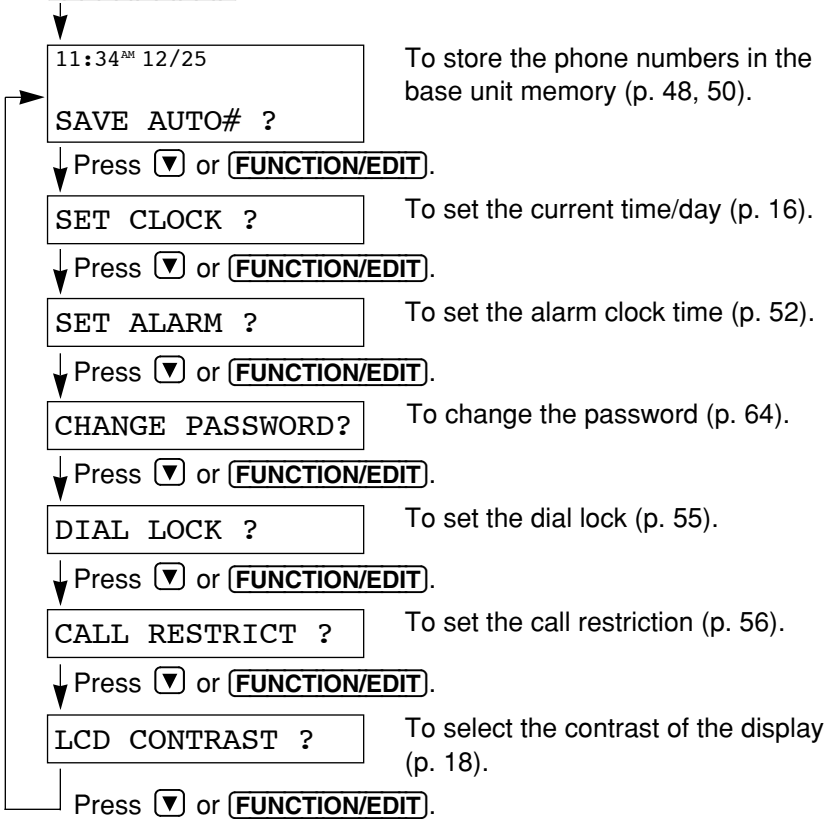

## During programming

- To scroll between the programming mode, press **▼** or **▲** or **FUNCTION/EDIT**.
- You can exit the programming mode any time by pressing **EXIT**.
- If you do not press any buttons for 60 seconds, the unit will return to the standby mode.



## With the Portable Unit

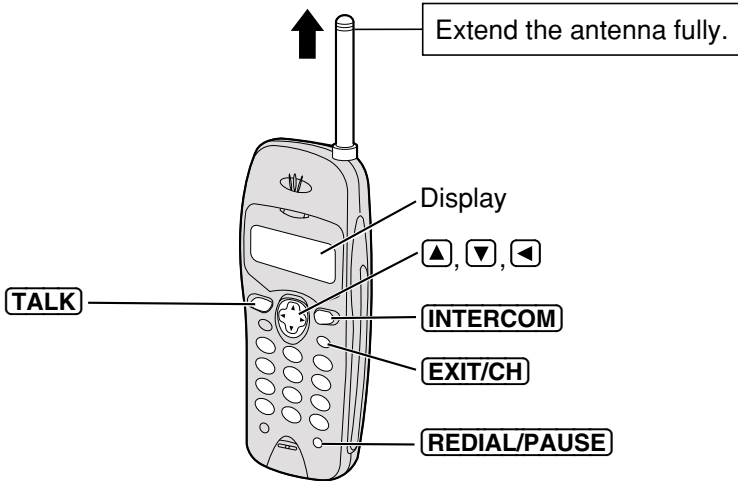

1 Press **TALK**.



2 Dial a phone number.

- The dialled number is displayed.
- After a few seconds, the display will show the length of the call.

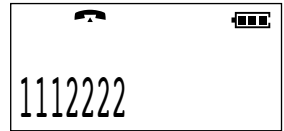

3 To hang up, press **TALK** or place the portable unit on the charger.

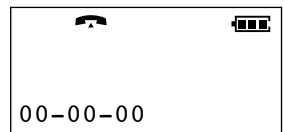

- While the portable unit is in use, the IN USE indicator on the base unit lights.
- If “Out of range” is displayed and an alarm tone sounds in step 1;  
— move closer to the base unit or place the portable unit on the charger and try again, or  
— another portable unit is in use.
- If “Not available” is displayed and busy tones sound when you press **TALK**, the base unit is in use.
- When the base unit is in use, the portable unit user cannot hear/join the base unit conversation, and vice versa (— **Conversation Protection**).

## To redial the last number dialled

Press **TALK** ➔ **REDIAL/PAUSE**.

## ➔ Making Calls

### To dial after confirming the entered number

1. Enter a phone number.

- If you misdial, press . Digits are erased from the right.
- To cancel, press **EXIT/CH**.



2. Press **TALK**.

- After a few seconds, the display will show the length of the call.



3. To hang up, press **TALK** or place the portable unit on the charger.

### To redial after confirming the last number dialed

Press **REDIAL/PAUSE** ➔ **TALK**.

### To select the receiver volume

Press  or  while talking.

- Each time you press  or , the volume level will change.
- The display will return to the length of the call.

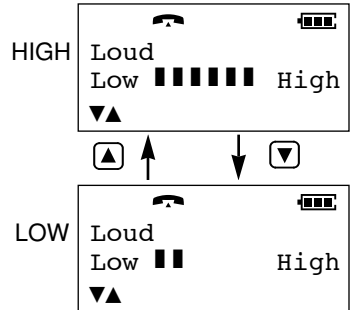

### If noise interferes with the conversation

Press **EXIT/CH** to select a clearer channel or move closer to the base unit.

### To put a call on hold

Press **INTERCOM** twice.

-  on the portable unit display flashes.
- "HOLD" is displayed on the base unit and the SP-PHONE indicator flashes.
- During the hold, the caller will hear music.

### To release the hold

From the portable unit, press **TALK**.

From the base unit, press **SP-PHONE** or lift the handset.



## Backlit LCD display

The backlit portable unit display will stay on for about 10 seconds after pressing a portable unit button or lifting the portable unit off the charger.

## Backlit keypad on the portable unit

The dialling buttons on the portable unit will light when you press a button or lift the portable unit off the charger, and flash when a call is received. The lights will go out about 10 seconds after pressing a button, lifting the portable unit off the charger or answering a call.

## With the Base Unit

You can make a call by simply lifting the handset and dialling the phone number. To hang up, place the handset on the cradle.

## Using the speakerphone

- 1 Press **SP-PHONE**.
  - The indicator lights.
- 2 Dial a phone number.
  - The dialled number is displayed.
  - After a few seconds, the display will show the length of the call.
- 3 When the other party answers, talk into the **MIC** (microphone).
- 4 To hang up, press **SP-PHONE**.
  - The SP-PHONE indicator light goes out.

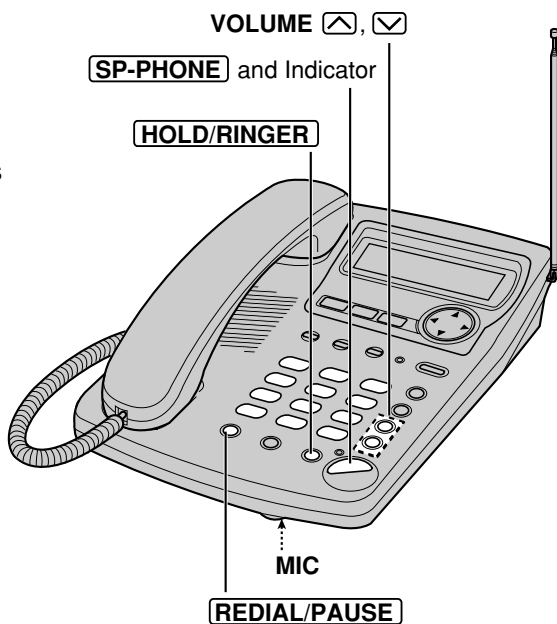

- "LINE BUSY" is displayed, while the portable unit is engaged in an outside call.

## ➔ Making Calls

### During the speakerphone operation:

- For best speakerphone performance, use in a quiet room and talk alternately with the caller.
- If the other party has difficulty hearing you, press **VOLUME**  to decrease the speaker volume. Decreasing the speakerphone volume will increase the microphone sensitivity.
- You can switch to the handset by lifting it up. To switch back to the speakerphone, press **(SP-PHONE)**.

### To adjust the handset volume (3 levels) or speaker volume (12 levels) while talking

To increase, press **VOLUME** .

To decrease, press **VOLUME** .

- The display shows the volume level for a few seconds.

Ex. Handset volume level: 2

11:34<sup>AM</sup> 12/25  
0-00-12  
□□ \_

Ex. Speaker volume level: 3

11:34<sup>AM</sup> 12/25  
0-00-12  
□□□ \_ \_ \_ \_ \_

### To redial the last number dialed

Lift the handset or press **(SP-PHONE)** ➔ **(REDIAL/PAUSE)**.

### To put a call on hold

Press **(HOLD/RINGER)**.

- The SP-PHONE indicator flashes.
- During the hold, the caller and the base unit speakerphone user will hear music.

11:34<sup>AM</sup> 12/25  
0-02-12  
HOLD

### To release the hold

From the base unit handset, press **(HOLD/RINGER)**.

From the base unit speakerphone, press **(SP-PHONE)** or lift the handset.

From the portable unit, press **(TALK)**. “” on the portable unit display flashes. After 3 beeps sound, press **(TALK)** again within 3 seconds.



# Answering Calls **Portable Unit** **Base Unit**

When a call is received, the unit rings and the CALLER ID indicator on the base unit flashes quickly. If you subscribe to a Caller ID service, the calling party's information will be displayed after the first ring (p. 26). In order to view the CALLER ID information, please wait until the second ring to answer a call.

## With the Portable Unit

Press **TALK**.

- You can also answer a call by pressing any dialling button **0** to **9**, **\*** or **#** (—Any Key Talk).

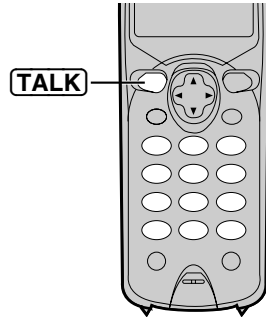

## With the Base Unit

You can answer a call by simply lifting the handset. To hang up, place the handset on the cradle.

### Using the speakerphone

- 1 Press **SP-PHONE**.
- 2 Talk into the **MIC**.
- 3 To hang up, press **SP-PHONE**.

- The display will show "INCOMING CALL" when receiving a call in case you do not subscribe to the Caller ID service.

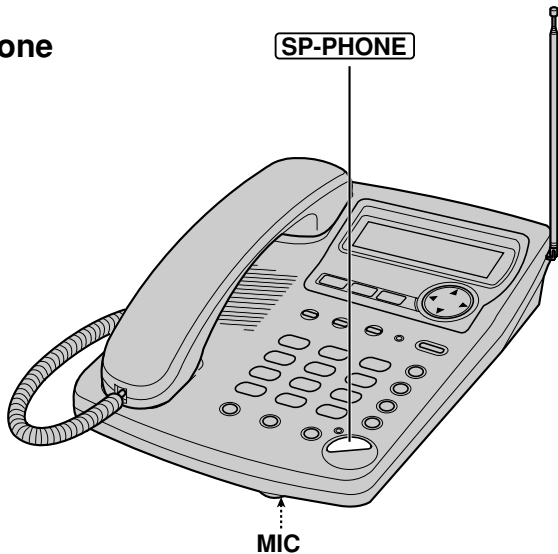

When the base unit and portable unit ringer volumes are set to OFF, they will not ring (p. 14, 15).

# Caller ID Service **Portable Unit** **Base Unit**

This unit is compatible with a Caller ID service offered by your telephone company. After subscribing to a Caller ID service, the calling party's information will be displayed on the portable unit and base unit after the first ring.

The unit can record information of up to 50 different callers, including the time and date the call was received and the number of times called, in the Caller List. The Caller List information is sorted from the most recent to the oldest call. When the 51st call is received, the oldest call is deleted.

Using the list, you can automatically call back a caller. You can store the callers' names and numbers from the Caller List in the directory, one-touch dialler or speed dialler. (The callers' names cannot be stored in the one-touch dialler and speed dialler.)

When a second call is received while talking, the new caller's phone number will be displayed (p. 62). (For Australia only)

## How caller information is displayed when a call is received

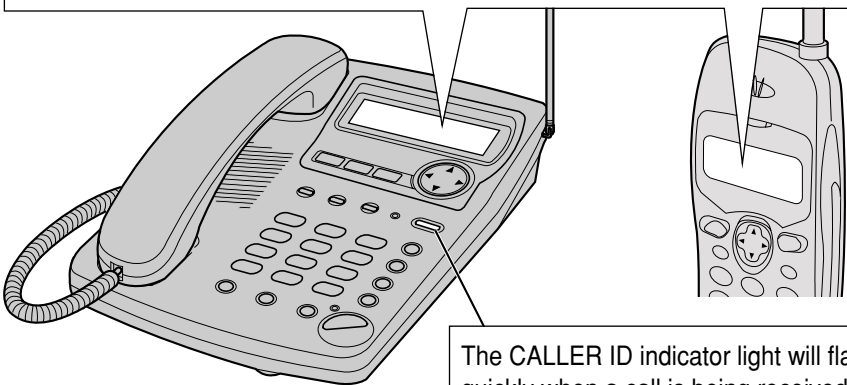
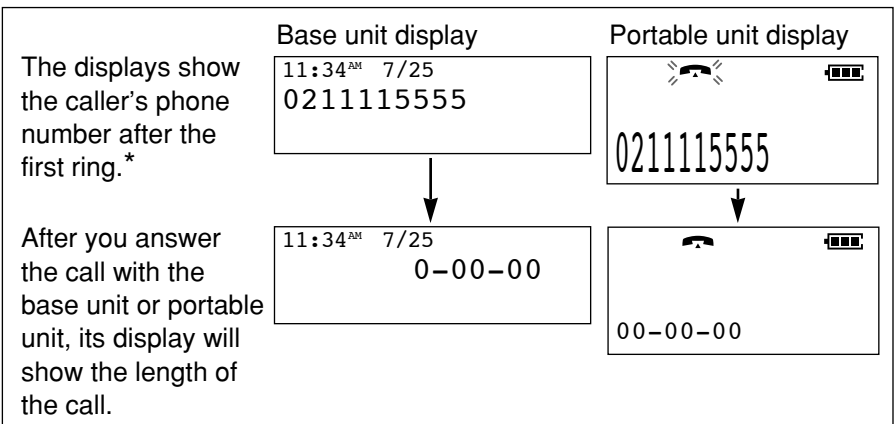

The CALLER ID indicator light will flash quickly when a call is being received.

**\*Private name display *Portable Unit***

If you receive a call from one of the same phone numbers stored in the directory, the caller's name will be displayed on the portable unit.



- To use this function, names and phone numbers must be stored in the directory (p. 40).
- This function is not available on the base unit.
- Caller information cannot be displayed in the following cases:
  - If the caller dialed from an area which does not provide a Caller ID service, the display will show "Out of area" (portable unit)/ "OUT OF AREA" (base unit).
  - If the caller has requested not to display his/her information, the display will show "Private caller" (portable unit)/ "PRIVATE CALLER" (base unit).
  - If a long distance call cannot be identified, the display will show "Long distance" (portable unit)/ "**LDC**" (base unit).
- If your unit is connected to a PBX which does not support Caller ID services, you cannot access those services.
- If the name display service is available in your area, the display will show caller's names. For further information, please contact your telephone company.

**For New Zealand Users:**

Your telephone company may not support the second caller display feature.

**To check the number of new calls**

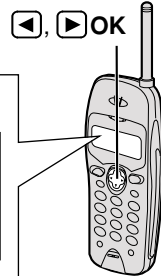

**With the portable unit:**

Press ◀ or ▶ OK on the portable unit.

For example, if you have received 10 new calls, the display on the right will be shown.

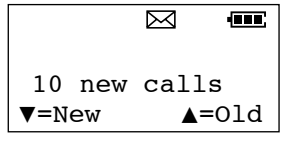

**With the base unit:**

The base unit display shows the number of new calls in the standby mode.

For example, if you have received 10 new calls, the display on the right will be shown.

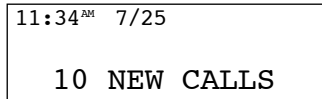

The CALLER ID indicator light will flash slowly when new calls have been received.



# Using the Caller List *Portable Unit* *Base Unit*

## Viewing the Caller List

To check who has called, follow the steps below.

**Make sure that the base unit and portable unit are in the standby mode.**

### With the portable unit

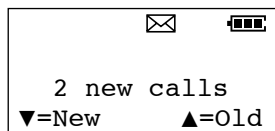

- 1 Press  or  **OK** on the portable unit to enter the Caller List.

- The number of new calls is displayed.



- 2 To search from the most recent call, press  (New key).

To search from the oldest call, press  (Old key).

- To scroll between callers, press  or .

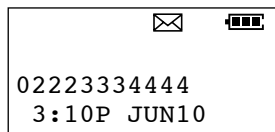

- 3 To exit the list, press **EXIT/CH**.

- The portable unit will return to the standby mode.

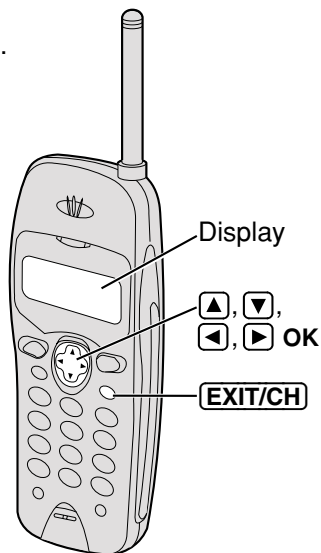

- Once new calls have been checked, "√" will be added.
- If "No items stored" is displayed in step 1, the Caller List is empty.
- If more than one call is received from the same caller, the date and time of the most recent call will be recorded. If the same caller calls again, the call entry with "√" will be deleted.
- If the base unit user makes a call when the portable unit user is viewing the Caller List, the portable unit will return to the standby mode.



## Ex. When you search from the most recent call with the portable unit:

Press or OK.

2 new calls  
▼=New ▲=Old

Press .

02223334444  
3:10P JUN10

Press .

\*   
NANCY BROWN  
0244448888  
1:54P JUN 9 x2

Press .

\*\*   
0123456789012345→  
10:38A JUN 9 ✓

Press .

To return to the previous caller, press .

To exit the Caller List, press **EXIT/CH**.

- The portable unit will return to the standby mode.

\* If you receive a call from one of the same phone numbers stored in the directory, the caller's name will be displayed. **(Private name display)**.

\*\* If an arrow (→) is displayed after the number, the whole phone number has not been shown. Press **#** (→) to see the remaining numbers. Press **\*** (←) to return to the previous display.

Press **#** (→).   
←678901  
10:38A JUN 9 ✓

Press **\*** (←).

### Display meaning:

- ✓ : You have checked this caller information, answered the call or called back the caller.
- x2-x9 : The number of times the same caller called (up to 9). After checking, "x2" - "x9" will be replaced with "✓".

## ➔ Using the Caller List

### With the base unit

1 Press **CALLER ID** to enter the Caller List.

- The most recent caller information is displayed.
- You can also enter the Caller List by pressing **▼** or **▲** on the base unit.

3:10<sup>PM</sup> 6/10<sup>NEW</sup>#03  
02223334444

2 To search from the most recent call, press **▼** or **CALLER ID**.

To search from the oldest call, press **▲**.

- To scroll between callers, press **▼** or **▲**.

“NEW” display

1:54<sup>PM</sup> 6/9<sup>NEW</sup>#02 ×2  
0244448888

3 To exit the list, press **EXIT**.

- The base unit will return to the standby mode.

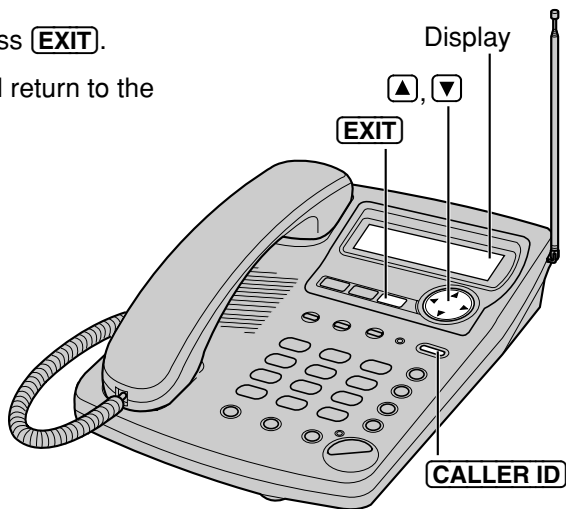

- Once new calls have been checked, “NEW” will disappear from the display.
- If “NO ITEM STORED” is displayed in step 1, the Caller List is empty.
- If more than one call is received from the same caller, the date and time of the most recent call will be recorded. If the same caller calls again, the call entry without “NEW” will be deleted.
- If the portable unit user makes a call when the base unit user is viewing the Caller List, the base unit will return to the standby mode.



## Ex. When you search from the most recent call with the base unit:

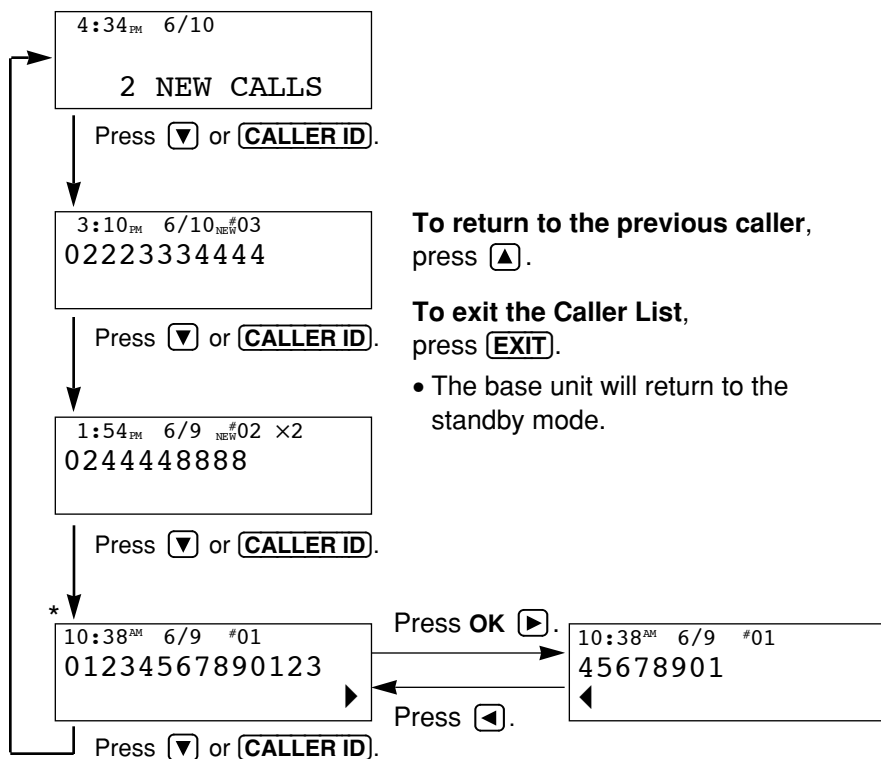

\* If an arrow (▶) is displayed below the number, the whole phone number has not been shown. Press OK ► to see the remaining numbers. Press ◀ to return to the previous display.

### Display meaning:

**NEW** : You have not yet checked this caller information, answered the call or called back the caller.

**#1—#50** : The memory number of each caller (up to 50). The largest number is the most recent caller.

**x2—x9** : The number of times the same caller called (up to 9).



## ➔ Using the Caller List

### Calling Back from the Caller List

#### For New Zealand Users:

Your telephone service provider may charge you for a local call when it is dialled with an area code prefix. If the charge for a local call is unacceptable, only the 7-digits of the local number should be dialled from your telephone. Do not dial the "0" prefix or the area code digit.

#### With the portable unit

1 Press  or  **OK** on the portable unit to enter the Caller List.

2 Press  or  repeatedly to find the desired caller.

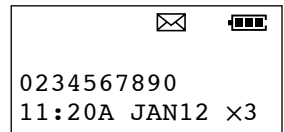

3 Press **TALK**.

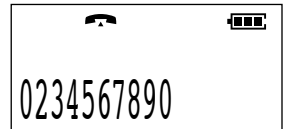

- The displayed phone number is dialled automatically.
- After a few seconds, the display will show the length of the call.



- If you need to edit a phone number, see page 33.
- If a phone number is not displayed in the caller information, you cannot call back that caller.

#### With the base unit

1 Press **CALLER ID** to enter the Caller List.

- You can also enter the Caller List by pressing  or  on the base unit.

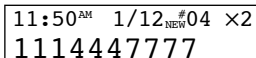

2 Press  or  repeatedly to find the desired caller.

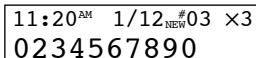

3 Lift the handset or press **SP-PHONE**.

- The displayed phone number is dialled automatically.
- After a few seconds, the display will show the length of the call.

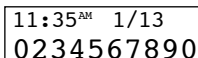

- If you need to edit a phone number, see page 34.
- If a phone number is not displayed in the caller information, you cannot call back that caller.





## Editing the Caller's Phone Number

You can edit a phone number in the Caller List. After editing the number, you can continue with calling back or storing procedures.

**Make sure that the base unit and portable unit are in the standby mode.**

### For New Zealand Users:

Your telephone service provider may charge you for a local call when it is dialled with an area code prefix. If the charge for a local call is unacceptable, only the 7-digits of the local number should be dialled from your telephone. Do not dial the "0" prefix or the area code digit.

### With the portable unit

- 1 Press or **OK** on the portable unit to enter the Caller List.

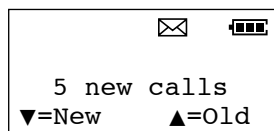

- 2 Press or repeatedly to find the desired caller.

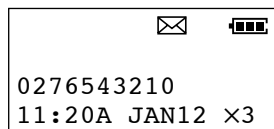

- 3 Press **FUNCTION/EDIT**.

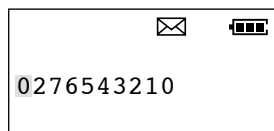

- 4 Add a number to the current number.
  - Each time you press , the digit to the left of the cursor is erased.

- 5 After editing the number, you can continue with calling back or storing procedures.
  - To call back, press **TALK** (p. 32).
  - To store the number in the directory, press **OK** and follow the instructions on the display (see page 35, from step 3).

- The number edited in step 4 will not be maintained in the Caller List.

## ➔ Using the Caller List

---

### With the base unit

1 Press **CALLER ID** to enter the Caller List.

- You can also enter the Caller List by pressing **▼** or **▲** on the base unit.

```
11:50AM 1/12NEW#05 ×2  
1114447777
```

2 Press **▼** or **▲** repeatedly to find the desired caller.

```
11:20AM 1/12NEW#03 ×3  
0276543210
```

3 Press **FUNCTION/EDIT**.

- The number furthest to the left will flash.

```
11:20AM 1/12NEW#03 ×3  
0276543210
```

4 Add a number to the current number.

- To delete the number flashing, press **CLEAR**.
- If you enter a wrong number, press **CLEAR** then the correct number.

5 After editing the number, you can continue with calling back or storing procedures.

To call back, lift the handset or press **SP-PHONE** (p. 32).

To store the number in the one-touch dialler, press one of the one-touch auto dial buttons (**M1**), (**M2**) or (**M3**).

To store the number in the speed dialler, press **AUTO** then enter a memory station number (**0** to **9**).

- The number edited in step 4 will not be maintained in the Caller List.



# Storing Caller List Information in the Directory

## Using the portable unit

You can store phone numbers that are in the Caller List into the directory.

**Make sure that the base unit and portable unit are in the standby mode.**

- 1 Press or **OK** on the portable unit to enter the Caller List.

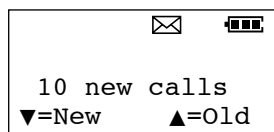

- 2 Press or repeatedly to find the caller you want to store in the directory, and press **OK**.

- If the number requires editing, see page 33.

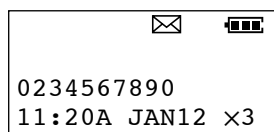

- 3 While the arrow points to "Save directory", press **OK** (Yes key).

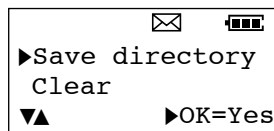

### ■ When the caller's name is not displayed in the Caller List:

- a) If a name is not required, press **OK** (Save key).

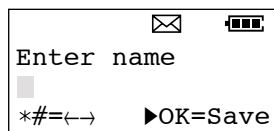

- b) If a name is required, enter the name (p. 42). When finished, press **OK** (Save key).

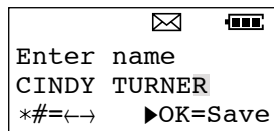

- A beep sounds.
- To store other numbers, repeat steps 2 and 3.
- To return to the standby mode, press **EXIT/CH**.

- You can exit the programming mode any time by pressing **EXIT/CH**.
- If the display shows "Memory is full" in step 3, the display will return to step 2. Press **EXIT/CH** to exit the list.  
To erase other stored items from the directory, see page 47.
- You cannot store caller information in the directory if a phone number is not displayed.

## ➔ Using the Caller List

---

# Storing Caller List Information in the One-Touch Dialler Memory

### Using the base unit

You can store phone numbers that are in the Caller List into the One-Touch Dialler memory.

**Make sure that the base unit and portable unit are in the standby mode.**

1 Press **CALLER ID** to enter the Caller List.

- You can also enter the Caller List by pressing **▼** or **▲** on the base unit.

```
11:50AM 1/12NEW#04 ×2  
1114447777
```

2 Press **▼** or **▲** repeatedly to find the caller you want to store in memory.

- If the number requires editing, see page 34.

```
11:20AM 1/12NEW#03 ×3  
0234567890
```

3 Press one of the one-touch auto dial buttons (**M1**, **M2** or **M3**).  
(Ex. **M1** is pressed.)

- A beep sounds.
- To store other numbers, repeat steps 2 and 3.
- To return to the standby mode, press **EXIT**.

```
11:20AM 1/12NEW#03 ×3  
0234567890  
SAVE IN M1
```

- You can exit the programming mode any time by pressing **EXIT**.
- You cannot store caller information in the One-Touch Dialler memory if a phone number is not displayed.



# Storing Caller List Information in the Speed Dialler Memory

## Using the base unit

You can store phone numbers that are in the Caller List into the Speed Dialler memory.

**Make sure that the base unit and portable unit are in the standby mode.**

1 Press **CALLER ID** to enter the Caller List.

- You can also enter the Caller List by pressing **▼** or **▲** on the base unit.

```
11:50AM 1/12NEW#04 ×2  
1114447777
```

2 Press **▼** or **▲** repeatedly to find the caller you want to store in memory.

- If the number requires editing, see page 34.

```
11:20AM 1/12NEW#03 ×3  
0234567890
```

3 Press **AUTO**.

```
11:20AM 1/12NEW#03 ×3  
0234567890  
PRESS 0-9
```

4 Enter a memory station number (**0** to **9**).  
(Ex. **1** is pressed as a memory station number.)

```
11:20AM 1/12NEW#03 ×3  
0234567890  
SAVE IN AUTO 1
```

- A beep sounds.
- To store other numbers, repeat steps 2 through 4.
- To return to the standby mode, press **EXIT**.

- You can exit the programming mode any time by pressing **EXIT**.
- You cannot store caller information in the Speed Dialler memory if a phone number is not displayed.

## ➔ Using the Caller List

### Erasing Caller List Information

After checking the Caller List, you can erase some or all of the entries. **Make sure that the base unit and portable unit are in the standby mode.**

#### To erase a specific caller from the Caller List

##### With the portable unit

- 1 Press or **OK** on the portable unit to enter the Caller List.
- 2 Press or repeatedly to find the caller you want to erase from the Caller List, and press **OK**.
- 3 Press or to select "Clear".
- 4 Press **OK** (Yes key).
  - A beep sounds and the information is erased.
  - After a few seconds, the display will show the previous caller information.
  - To return to the standby mode, press **EXIT/CH**.

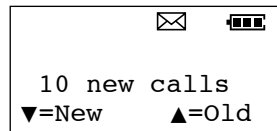

10 new calls  
▼=New ▲=Old

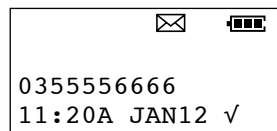

0355556666  
11:20A JAN12 ✓

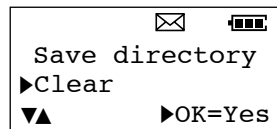

Save directory  
▶Clear  
▼▲ ▶OK=Yes

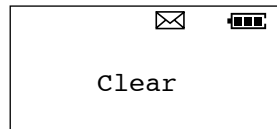

Clear

##### With the base unit

- 1 Press **CALLER ID** to enter the Caller List.
  - You can also enter the Caller List by pressing or on the base unit.
- 2 Press or repeatedly to find the caller you want to erase from the Caller List.
- 3 Press **CLEAR**.
  - A beep sounds and the information is erased.
  - After a few seconds, the display will show the previous caller information.
  - To return to the standby mode, press **EXIT**.

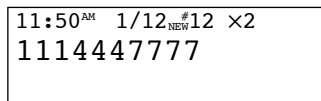

11:50<sup>AM</sup> 1/12<sup>#12</sup> x2  
1114447777

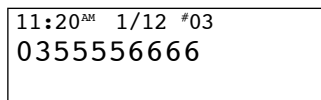

11:20<sup>AM</sup> 1/12 #03  
0355556666

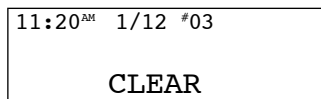

11:20<sup>AM</sup> 1/12 #03  
CLEAR

## To erase all entries in the Caller List

### With the portable unit

1 Press or **OK** on the portable unit to enter the Caller List.

- Make sure that “0 new call” is displayed.

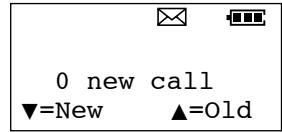

2 Press **OK**.

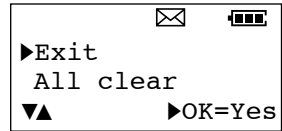

3 Press or to select “All clear”.

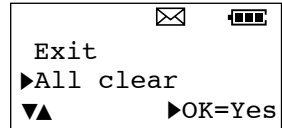

4 Press **OK** (Yes key).

- A beep sounds and all entries are erased.
- The portable unit will return to the standby mode.

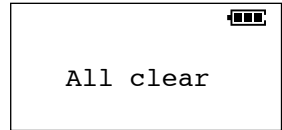

### With the base unit

1 Make sure that “0 NEW CALL” is displayed, then press **CLEAR**.

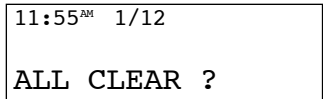

2 Press **OK** .

- A beep sounds and all entries are erased.
- The base unit will return to the standby mode and “NO ITEM STORED” is displayed.

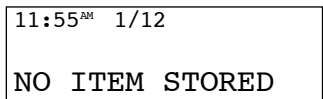
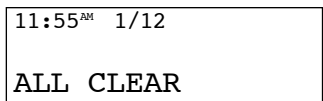

# Using the Directory **Portable Unit**

You can store up to 30 names and phone numbers in the directory. All directory items are sorted by the first word in alphabetical order.

Using the directory, you can make a call by selecting a name on the portable unit display.

You cannot access numbers stored in another portable unit or the base unit from a portable unit.

## Storing Names and Numbers in the Directory

Make sure that the portable unit is in the standby mode.

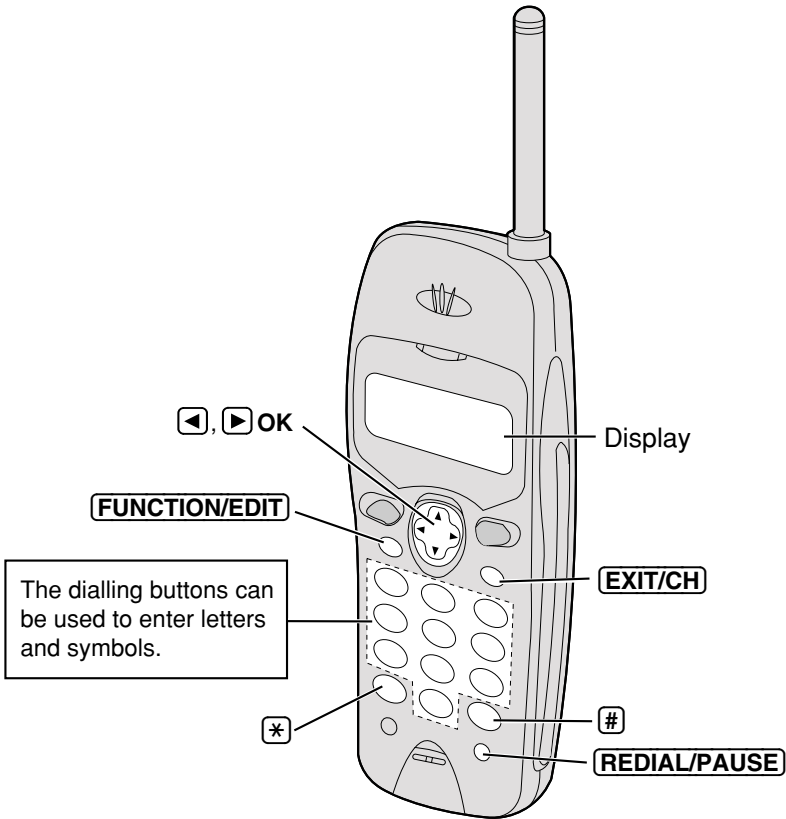





1 Press **FUNCTION/EDIT** on the portable unit.

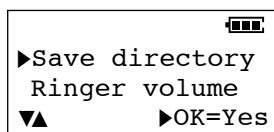

2 While the arrow points to "Save directory", press **OK** (Yes key).

- The display shows the number of stored items in the directory.

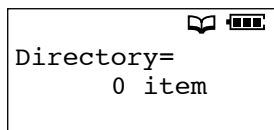

3 Enter a name, up to 15 characters, with the dialling buttons, **\*** (←) or **#** (→).

- See the steps for entering names and symbols (p. 42).
- If a name is not required, press **OK** (Next key) and go to step 5.

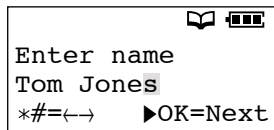
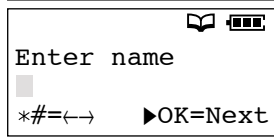

4 Press **OK** (Next key).

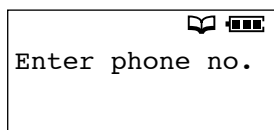

5 Enter a phone number up to 22 digits.

- Each time you press **◀** the digit to the left of the cursor is erased.

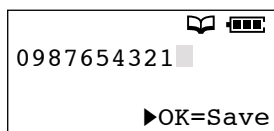

6 Press **OK** (Save key).

- A beep sounds.
- The display will return to step 1. You can continue storing other items after pressing **OK** (Yes key).
- To return to the standby mode, press **EXIT/CH**.

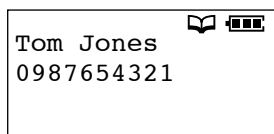

- If a pause is required for dialling, **REDIAL/PAUSE** can be stored in a phone number counting as one digit (p. 62) in step 5.
- You can exit the programming mode any time by pressing **EXIT/CH**.
- If the display shows "Memory is full" in step 2, the display will return to step 1. Press **EXIT/CH**, and erase other stored items from the directory (p. 47).

## ➔ Using the Directory

### Steps for Entering Names and Symbols

The dialling buttons on the portable unit can be used to enter letters and symbols. Each button selects a character as shown below.

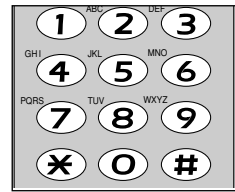

Keys	Number of times key is pressed										
	1	2	3	4	5	6	7	8	9	10	11
1	#	&	'	(	)	*	,	-	.	/	1
2	A	B	C	a	b	c	2				
3	D	E	F	d	e	f	3				
4	G	H	I	g	h	i	4				
5	J	K	L	j	k	l	5				
6	M	N	O	m	n	o	6				
7	P	Q	R	S	p	q	r	s	7		
8	T	U	V	t	u	v	8				
9	W	X	Y	Z	w	x	y	z	9		
0	0	Blank									
*	To move the cursor █ to the left.										
#	To move the cursor █ to the right.										

### If you make a mistake while entering a name

Use \* (←) or # (→) to move the cursor to the incorrect character, press ◀ to delete and enter the correct character. Each time you press ◀, a character is erased from the right.



## For example, to enter “Tom Jones”:

- 1 Press **FUNCTION/EDIT** on the portable unit.
- 2 While the arrow points to “Save directory”, press **OK** (Yes key).
- 3 Press **8**.
- 4 Press **6** six times, then press **#** (→) to move the cursor to the right.
- 5 Press **6** four times.
- 6 Press **#** (→) twice to enter a blank.
- 7 Press **5**.
- 8 Press **6** six times, then press **#** (→) to move the cursor to the right.
- 9 Press **6** five times.
- 10 Press **3** five times.
- 11 Press **7** eight times.
- 12 When finished, press **OK** (Next key).
  - To enter a phone number, see page 41, from step 5.

Directory=  
20 items

Enter name  
\*#=<→ ▶OK=Next

T

To

Tom

Tom

Tom J

Tom Jo

Tom Jon

Tom Jone

Enter name  
Tom Jones  
\*#=<→ ▶OK=Next

Enter phone no.

- While entering names, the cursor will flash on the display.
- To enter another character using the same dialling button, press **#** (→) to move the cursor to the next space.

## ➔ Using the Directory

### Finding Items in the Directory

Make sure that the portable unit is in the standby mode.

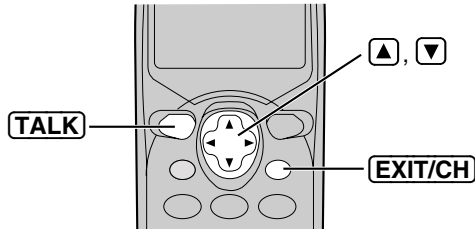

- 1 Press or on the portable unit to enter the directory list.
  - The first item or last item is displayed.

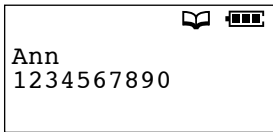

- 2 Press or repeatedly until the desired item is displayed.
  - All directory items are stored in the order shown on the right.

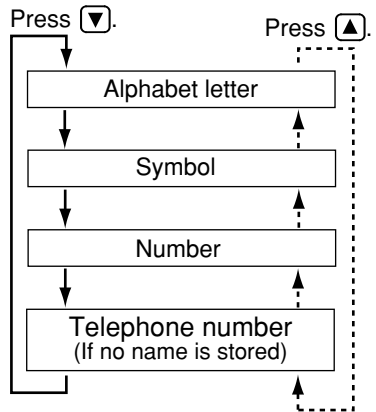

### To search for a name by initial

- 1 Press or on the portable unit to enter the directory.
- 2 Press the dialling button for the first letter of the desired name until any name with the same initial is displayed (see the Index table on page 45).  
Ex. To find "Frank", press until the first item under "F" is displayed.
- 3 Press repeatedly until the desired name is displayed.

- You can leave the directory list any time by pressing .
- If "No items stored" is displayed in step 1, the directory is empty.



Keys	Index	Keys	Index
①	Other symbols, 1	⑥	M, N, O, 6
②	A, B, C, 2	⑦	P, Q, R, S, 7
③	D, E, F, 3	⑧	T, U, V, 8
④	G, H, I, 4	⑨	W, X, Y, Z, 9
⑤	J, K, L, 5	⑩	0

## Dialling from the Directory

Make sure that the base unit and portable unit are in the standby mode.

1 Press or on the portable unit repeatedly to find the directory item that you want to dial.

- To search for the item by initial, see page 44.
- To exit the directory, press **EXIT/CH**.

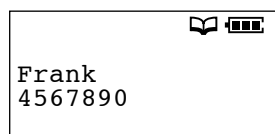

2 Press **TALK**.

- The number is dialled automatically.

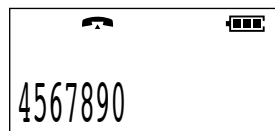

3 To hang up, press **TALK** or place the portable unit on the charger.

- You can leave the directory list any time by pressing **EXIT/CH**.
- Numbers stored in the portable unit can only be dialled by the portable unit.

## ➔ Using the Directory

### Editing an Item in the Directory

Make sure that the portable unit is in the standby mode.

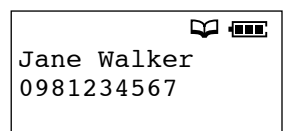
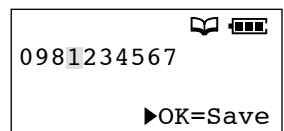
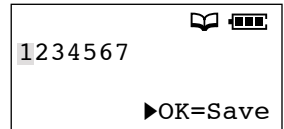
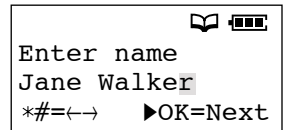
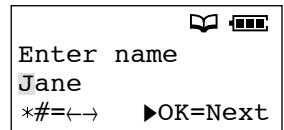
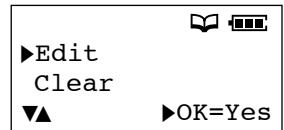
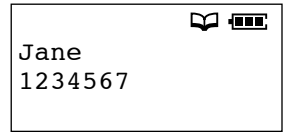

- 1 Press or on the portable unit repeatedly to find the directory item you want to change, then press **OK**.
  - To search for the item by initial, see page 44.
- 2 While the arrow points to “Edit”, press **OK** (Yes key).
- 3 Edit the name by using the dialling buttons, (←) or (→) (p. 42), up to 15 characters.
  - If you do not need to change the name, go to step 4.
- 4 Press **OK** (Next key).
  - If you do not need to change the number, press **OK** (Save key).
- 5 Add a number to the current number.
  - Each time you press the digit to the left of the cursor is erased.
- 6 When finished, press **OK** (Save key).
  - The display will return to step 1. You can continue editing other items.
  - To return to the standby mode, press **EXIT/CH**.



- You can exit the programming mode any time by pressing **EXIT/CH**.

# Erasing an Item from the Directory

Make sure that the portable unit is in the standby mode.

- 1 Press  or  on the portable unit repeatedly to find the directory item you want to erase.
  - To search for the item by initial, see page 44.



- 2 Press  OK.

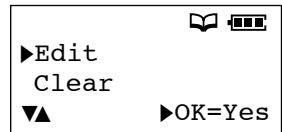

- 3 Press  or  to select "Clear".

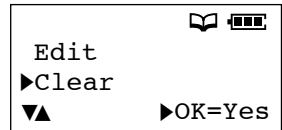

- 4 Press  OK (Yes key).
  - The display will show the next item.
  - To return to the standby mode, press **EXIT/CH**.

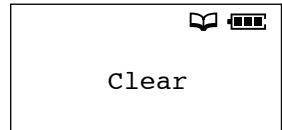

- You can exit the programming mode any time by pressing **EXIT/CH**.

# One-Touch Dialler **Base Unit**

## Storing Phone Numbers in Memory

You can store up to 3 phone numbers in the one-touch auto dial buttons.

Do not press any one-touch auto dial buttons before storing to prevent misoperation.

You cannot access any numbers stored in a portable unit from the base unit.

**Make sure that the base unit and portable unit are in the standby mode.**

1 Press **FUNCTION/EDIT** on the base unit.

11:34<sup>AM</sup> 11/25

SAVE AUTO# ?

2 While "SAVE AUTO# ?" is displayed, press **OK** .

11:34<sup>AM</sup> 11/25

ENTER PHONE NO.

3 Enter a phone number up to 22 digits.

- If you enter a wrong number, press **CLEAR** and enter the correct number.

11:34<sup>AM</sup> 11/25

1234567890

AUTO OR M# =SAVE

4 Press one of the one-touch auto dial buttons (**M1**, **M2** or **M3**).  
(Ex. **M1** is pressed.)

11:34<sup>AM</sup> 11/25

1234567890

SAVE IN M1

- A beep sounds.
- To store other numbers, repeat steps 2 through 4.
- To return to the standby mode, press **EXIT**.

- If a pause is required for dialling, **REDIAL/PAUSE** can be stored in a phone number counting as one digit (p. 62) in step 3.
- You can exit the programming mode any time by pressing **EXIT**.

### To erase a stored number

1. Press **FUNCTION/EDIT** on the base unit.

2. Press **OK** .

3. Press one of the one-touch auto dial buttons (**M1**, **M2** or **M3**) required.

- A beep sounds.



# Dialling a Stored Number

- 1 Lift the handset or press **SP-PHONE**.
- 2 Press the required one-touch auto dial button (**M1**, **M2** or **M3**).
  - The stored number is dialled.

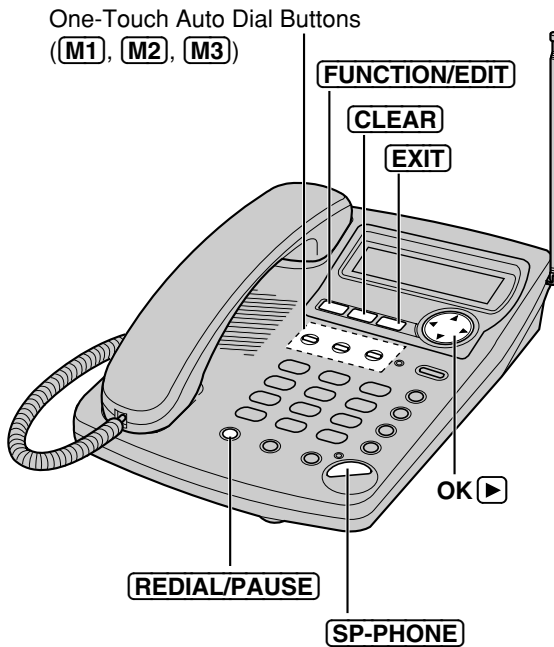

- Numbers stored in the base unit can only be dialled by the base unit.

# Speed Dialler **Base Unit**

## Storing Phone Numbers in Memory

You can store up to 10 phone numbers in the base unit. The dialling buttons (0 to 9) function as memory stations.

You cannot access any numbers stored in a portable unit from the base unit.

**Make sure that the base unit and portable unit are in the standby mode.**

1 Press **FUNCTION/EDIT** on the base unit.

11:34<sup>AM</sup> 11/25

SAVE AUTO# ?

2 While "SAVE AUTO# ?" is displayed, press **OK** .

11:34<sup>AM</sup> 11/25

ENTER PHONE NO.

3 Enter a phone number up to 22 digits.

- If you enter a wrong number, press **CLEAR** and enter the correct number.

11:34<sup>AM</sup> 11/25

1234567890

AUTO OR M# =SAVE

4 Press **AUTO**.

11:34<sup>AM</sup> 11/25

PRESS 0-9

5 Enter a memory station number (0 to 9).  
(Ex. 1 is pressed.)

11:34<sup>AM</sup> 11/25

1234567890

SAVE IN AUTO 1

- A beep sounds.
- To store other numbers, repeat steps 2 through 5.
- To return to the standby mode, press **EXIT**.

- If a pause is required for dialling, **REDIAL/PAUSE** can be stored in a phone number counting as one digit (p. 62) in step 3.
- You can exit the programming mode any time by pressing **EXIT**.

## To erase a stored number

1. Press **FUNCTION/EDIT** on the base unit.
2. Press **OK** .
3. Press **AUTO**.
4. Press one of the memory station numbers (**1** to **9**) for the phone number to be erased.
  - A beep sounds.

## Dialling a Stored Number

- 1 Lift the handset or press **SP-PHONE**.
- 2 Press **AUTO**.
- 3 Press a memory station number (**0** to **9**).
  - The stored number is dialled.

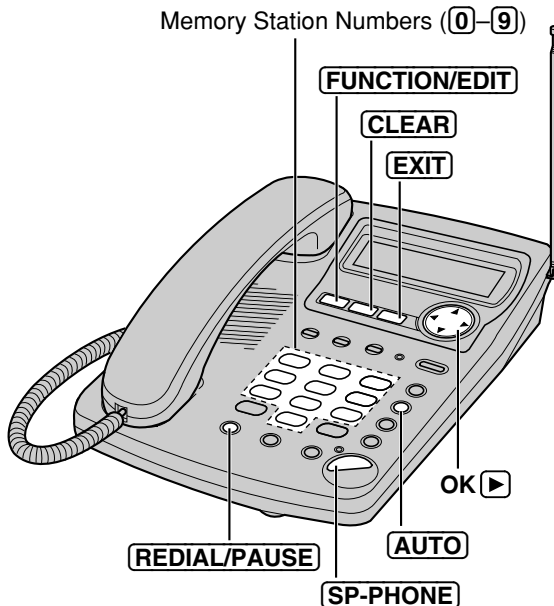

- Numbers stored in the base unit can only be dialled by the base unit.

# Using the Alarm Clock **Base Unit**

One of the portable units or the base unit will sound an alarm at a preset time for 1 minute. The alarm sounds at the HIGH level, even if the portable unit and base unit ringer volumes are set to OFF.

## Setting the alarm clock time

After setting the alarm clock time, the unit will automatically turn on the alarm clock.

**Adjust the current time before setting the time for the alarm clock (p. 16).**

**Make sure that the base unit and portable unit are in the standby mode.**

1 Press **FUNCTION/EDIT** on the base unit.

11:34<sup>AM</sup> 12/25

SAVE AUTO# ?

2 Press **▼** or **▲** repeatedly until "SET ALARM ?" is displayed.

11:34<sup>AM</sup> 12/25

SET ALARM ?

3 Press **OK** **▶**.

12:00<sup>AM</sup>

()

ENTER TIME

4 Enter the desired time (hour and minute) using a 4-digit number. (Ex. To set 6:30, enter "0630".)

06:30<sup>AM</sup>

()

ENTER TIME

- For AM/PM setting: Enter numbers between 0100 and 1259.  
For 24-hour clock: Enter numbers between 0000 and 2359.

5 Press **OK** **▶**.

- If numbers between 0000 and 0059, or 1300 and 2359 are entered, the time will automatically be set using the 24-hour clock. Skip the steps 6 and 7 and go to the step 8.

06:30<sup>AM</sup>

()

#=AM/PM



6 Press **#** to select "AM", "PM" or 24-hour clock. (Ex. You select "PM".)

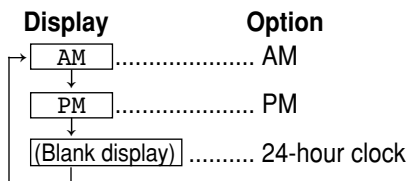
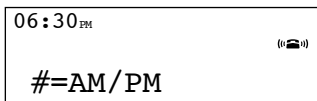

- Each time you press **#**, the selection will change on the display.

7 Press **OK**

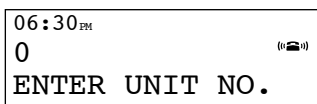

8 Enter the desired portable unit numbers (**1** to **4**).  
OR  
Enter **0** for the base unit.

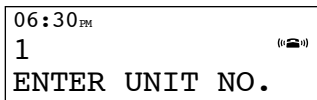

- The selected unit no. is displayed.
- A portable unit number which has not been registered cannot be selected. To register a portable unit, see page 66.

9 Press **OK**

- A beep sounds.
- To return to the standby mode, press **EXIT**.
- The alarm clock is turned on and "(📞)" is displayed on the base unit.

- If 6 beeps sound in step 7, the set time is not correct. Restart from step 1.

## ➡ Using the Alarm Clock

---

### Turning off the alarm clock

1. Press **FUNCTION/EDIT** on the base unit.
2. Press **▼** or **▲** repeatedly until “SET ALARM ?” is displayed.
3. Press **OK** **▶**.
4. Press **CLEAR**.
  - “(📞)” will disappear on the base unit display.
  - To return to the standby mode, press **EXIT**.

### Stopping the alarm clock

#### Portable unit:

Press any dialling button **0** to **9**, **\*** or **#**.

#### Base unit:

Press any dialling button **0** to **9**, **\*** or **#**.

- After the alarm sounds, the alarm clock turns off.
- When you press **TALK** or **SP-PHONE** while the alarm is sounding, the unit will change to the talk mode. When you press **INTERCOM** or **INTERCOM/LOCATOR**, the unit will change to the intercom mode.
- If the unit is in the talk, speakerphone or intercom mode during the alarm time, the alarm will not sound and the alarm clock will turn off.





You can prevent the portable unit and base unit from making a call to any number except the one pre-programmed in the memory of one-touch auto dial buttons. Once you locked the dialling buttons, even emergency numbers cannot be dialled. Only incoming calls are accepted until the dial lock is cancelled.

Before using this feature, we recommend storing emergency numbers in the memory of one-touch auto dial buttons (p. 48). Even if the dialling buttons are locked, the numbers stored in these buttons can be dialled.

- If you choose not to program emergency numbers, but plan to use the dial lock, any numbers programmed into the One-Touch Dialler can be accessed.

## Setting the dial lock

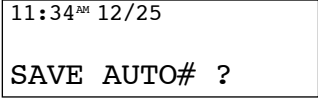
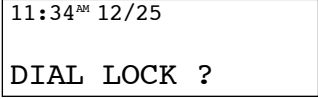
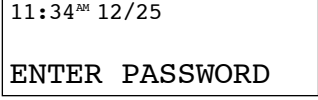
Make sure that the base unit and portable unit are in the standby mode.

- 1 Press **FUNCTION/EDIT** on the base unit.  

- 2 Press **▼** or **▲** repeatedly until "DIAL LOCK ?" is displayed.  

- 3 Press **OK** **▶**.
  - If you have not set a new password (p. 64), you will not be prompted to enter one. Go to step 5.
- 4 Enter the password (p. 64), then press **OK** **▶**.
  - If the wrong password is entered, 6 beeps will sound. Enter the correct password, then press **OK** **▶**.
- 5 Press **▼** or **▲** to select "LOCK".  

- 6 Press **OK** **▶** (SAVE key).
  - A beep sounds.
  - To return to the standby mode, press **EXIT**.

If the dialling buttons on the base unit are pressed, "DIAL LOCKED" will be displayed.

## ➔ Dial Lock

You can use the following features while the dialling buttons are locked.

- Dialling a number you programmed into the memory of one-touch auto dial buttons (p. 48).
- Storing names and numbers in memory (p. 40, 48, 50).
- Selecting the ringer volume (p. 14–15).
- Answering the second call by pressing **RECALL** (p. 62).

### Canceling the dial lock

Follow steps 1 through 4 on page 55. In step 5, select “UNLOCK”.

## Call Restriction **Base Unit**

You can prevent the portable unit and base unit from dialling phone numbers beginning with “0” or “00”. Phone numbers with the restricted leading digits cannot be dialled out. Phone numbers stored in the One-Touch Dialling are not affected by the call restriction setting.

Before using this feature, we recommend storing emergency numbers in the memory of one-touch auto dial buttons (p. 48). Even if the phone numbers buttons are restricted, the numbers stored in these buttons can be dialled.

- If you choose not to program emergency numbers, but plan to use the call restriction, any numbers programmed into the One-Touch Dialler can be accessed.

### Setting the call restriction

**Make sure that the base unit and portable unit are in the standby mode.**

1 Press **FUNCTION/EDIT** on the base unit.

11:34<sup>AM</sup> 12/25

SAVE AUTO# ?

2 Press **▼** or **▲** repeatedly until “CALL RESTRICT ?” is displayed.

11:34<sup>AM</sup> 12/25

CALL RESTRICT ?

3 Press **OK** **▶**.

11:34<sup>AM</sup> 12/25

- If you have not set a new password (p. 64), you will not be prompted to enter one. Go to step 5.

ENTER PASSWORD



**4** Enter the password (p. 64), then press **OK** .

- If the wrong password is entered, 6 beeps will sound. Enter the correct password, then press **OK** .
- The current restricted number is displayed.

11:34<sup>AM</sup> 12/25

=SAVE

**5** Press **0** to select the restricted no. ("0" or "00").  
(Ex. "0" is selected.)

- Each time you press **0**, the restricted no. will change.

11:34<sup>AM</sup> 12/25

0

=SAVE

**6** Press **OK**  (SAVE key).

- A beep sounds.
- To return to the standby mode, press **EXIT**.

When dialling a phone number beginning with the restricted no., "CALL RESTRICTED" is displayed on the base unit and not dialled out.

- If your unit is connected to a PBX, this function may not operate. Contact your PBX supplier for more information.

## Cancelling the call restriction

Follow steps 1 through 4. In step 5, press **CLEAR**.

# Intercom **Portable Unit** **Base Unit**

A 2-way intercom is available between the portable unit and base unit.

## Paging the base unit from the portable unit

### 1 Portable unit:

Press **INTERCOM**.

- The “” flashes.
- The base unit beeps for 1 minute.
- To stop paging, press **INTERCOM** again.

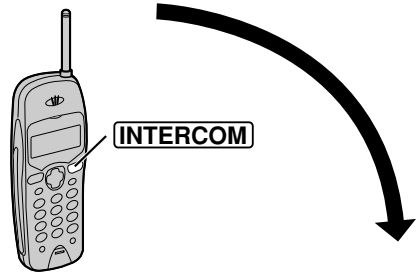

### 2 Base unit:

Lift the handset, then talk.

### 3 To end the intercom:

Place the handset on the cradle.

OR

Press **INTERCOM** on the portable unit.



- In step 2, the base unit user can also answer by pressing **LOCATOR/INTERCOM**. Then talk into the **MIC**.

To end the intercom from the base unit, press **LOCATOR/INTERCOM**.



## Paging the portable unit from the base unit

Using this feature, you can locate the portable unit, if misplaced.

### 1 Base unit:

Lift the handset and press **LOCATOR/INTERCOM**.

- The portable unit beeps for 1 minute.
- To stop paging, place the handset on the cradle.

### 2 Portable unit:

Press **INTERCOM** to answer.

- The intercom duration is displayed.

### 3 Base unit:

Talk into the handset.

### 4

To end the intercom:  
Place the handset on the cradle.  
OR  
Press **INTERCOM** on the portable unit.

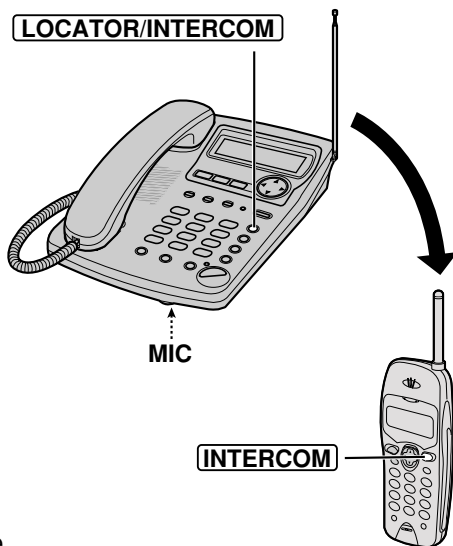

- In step 1, the base unit user can also page by pressing **LOCATOR/INTERCOM** directly. You do not need to lift the handset.
  - If the portable unit user does not answer, press **LOCATOR/INTERCOM** to stop paging.
  - If the portable unit user answers, talk into the **MIC**.  
To end the intercom from the base unit, press **LOCATOR/INTERCOM**.
- When using two or more portable units, see pages 68–69.

#### During the intercom:

- If the portable unit user has difficulty hearing the base unit user when the base unit user is using the speakerphone, decrease the speaker volume by pressing **VOLUME** .
- If two tones sound, an incoming call has been received. To answer, press **TALK**, **SP-PHONE** or place the handset and lift it again. The intercom is ended.

# Transferring a Call Using the Intercom

**Portable Unit** **Base Unit**

The intercom can be used during a call. This feature enables you to transfer a call between the portable unit and base unit.

## From the portable unit to the base unit

- 1 Portable unit:**  
During a call, press **INTERCOM**.
  - The call is put on hold.
  - If the base unit user does not answer, press **TALK**.
- 2 Base unit:**  
Lift the handset to answer the page.
- 3 Base unit:**  
To answer the call, press **HOLD/RINGER**.
  - The transfer is completed.

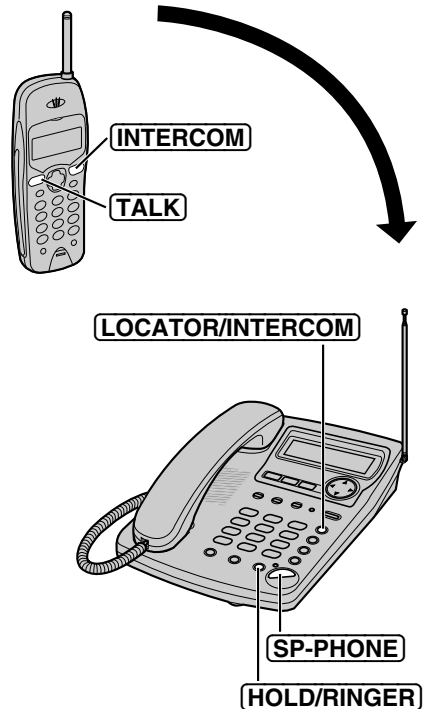

- In step 2, the base unit user can also answer the page by pressing **LOCATOR/INTERCOM**.  
To answer the call, press **SP-PHONE**.

## From the base unit to the portable unit

- 1 Base unit:**

During a call, press **HOLD/RINGER** then press **LOCATOR/INTERCOM**.

  - The call is put on hold.
  - If the portable unit user does not answer:
    - for the handset, press **HOLD/RINGER**.
    - for the speakerphone, press **SP-PHONE**.
- 2 Portable unit:**

Press **INTERCOM** to answer the page.
- 3 Portable unit:**

To answer the call, press **TALK**.

  - The transfer is completed.

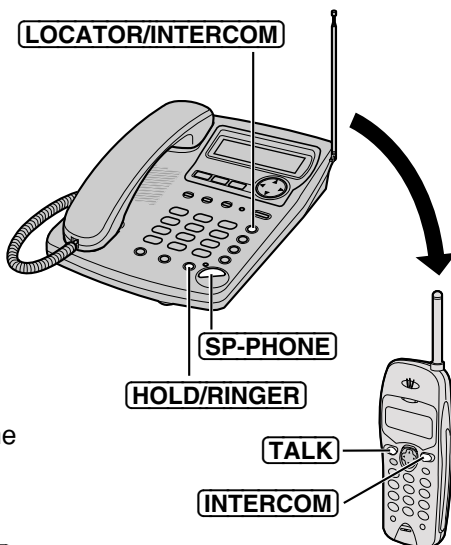

- If a portable unit is not registered, the base unit will not beep in step 1. To register a portable unit, see page 66.
- When using two or more portable units, see pages 70–71.

# Special Features

## How to Use the PAUSE Button **Portable Unit** **Base Unit** (For Analog PBX Line/Long Distance Service Users)

We recommend you press **REDIAL/PAUSE** if a pause is required for dialling with a PBX or to access a long distance service.

Ex: Line access number **9** (PBX)

**9** → **REDIAL/PAUSE** → Phone number

- Pressing **REDIAL/PAUSE** once creates a 3.5 second pause. This prevents misdialling when you redial or dial a stored number.
- Pressing **REDIAL/PAUSE** more than once increases the length of the pause between the numbers.

## Call Waiting and Caller ID Compatible (For Australia only) **Portable Unit** **Base Unit**

If you subscribe to Caller ID services, the display shows a second caller's information while talking. After you hear a call-waiting tone, the caller's phone number will be displayed.

Base unit	11:34 <sup>AM</sup> 12/25 0266667777		Portable unit	0266667777 ----Waiting----
-----------	---	---	---------------	-------------------------------

You can answer the second call, keeping the first call on hold.

Follow Telstra's instructions using **RECALL**.

- If the phone number is stored in the directory, the caller's name will be displayed on the portable unit (p. 27).
- Please contact Telstra for details and availability in your area.

### For Call Waiting Service Users in New Zealand

Adjust the recall time to 600 msec for use with Telecom's Call Waiting Service. Press **RECALL** if you hear a call-waiting tone while talking.

- The first call is put on hold and you can answer the second call.
- To return to the first caller, press **RECALL** again.
- Your telephone company may not support the second caller display feature.

## RECALL Button **Portable Unit** **Base Unit**

Pressing **RECALL** allows you to use special features of your host PBX such as transferring an extension call or accessing special telephone services (optional) such as call waiting.

### Selecting the recall time **Portable Unit**

The recall time depends on your telephone exchange or host PBX.

You can select from recall times: "700, 600, 400, 300, 250, 110, 100 or 90 ms (milliseconds)" **using the portable unit near the base unit.** Your phone comes from the factory set to "100 ms".



**Make sure that the base unit and portable unit are in the standby mode.**

1 Press **FUNCTION/EDIT** on the portable unit.

2 Press **▼** or **▲** repeatedly until the arrow points to "Program".



3 Press **▶ OK** (Yes key).

4 Press **▼** or **▲** repeatedly until the arrow points to "Set recall time".

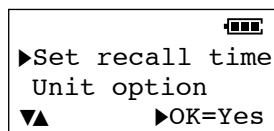

5 Press **▶ OK** (Yes key).

6 Press **▼** or **▲** repeatedly until the desired time is displayed.

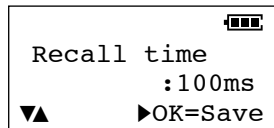

7 Press **▶ OK** (Save key).

- A beep sounds.
- To return to the standby mode, press **EXIT/CH**.

- You can exit the programming mode any time by pressing **EXIT/CH**.
- If 3 beeps sound and the display shows "Save error", move closer to the base unit and try again. If "Save error" is still displayed, place the portable unit on the charger. Start again from step 1.

**For Australia Users:**

- You can access Telstra's "EASY CALL" service by having the recall time set at 100 msec, and then follow Telstra's "EASY CALL" instructions to operate this service.
- If you are connected via a PBX, a longer recall time may be necessary to use PBX functions (transferring a call etc.). Consult your PBX installer for the correct setting.

**For New Zealand Users:**

Adjust the recall time to 600 msec for use with Telecom's Call Waiting Service. Press **RECALL** if you hear a call-waiting tone while talking.

- The first call is put on hold and you can answer the second call.
- To return to the first caller, press **RECALL** again.
- Your telephone company may not support the second caller display feature.
- If you are connected via a PBX, a longer or shorter recall time may be necessary to use PBX functions (transferring a call etc.). Consult your PBX installer for the correct setting.

## ➔ Special Features

### Setting the Password **Base Unit**

You can change the password for the dial lock and call restriction. Your phone comes from the factory set to “1111”.

**Make sure that the base unit and portable unit are in the standby mode.**

1 Press **FUNCTION/EDIT** on the base unit.

11:34<sup>AM</sup> 12/25

SAVE AUTO# ?

2 Press **▼** or **▲** repeatedly until “CHANGE PASSWORD?” is displayed.

11:34<sup>AM</sup> 12/25

CHANGE PASSWORD?

3 Press **OK** **▶**.

11:34<sup>AM</sup> 12/25

CURRENT PASSWORD

4 Enter the current password.

11:34<sup>AM</sup> 12/25

----  
CURRENT PASSWORD

5 Press **OK** **▶**.

- If the wrong password is entered, 6 beeps will sound. Enter the correct password, then press **OK** **▶**.

11:34<sup>AM</sup> 12/25

NEW PASSWORD

6 Enter a new password using a 4-digit number (0000–9999).  
(Ex. “1234” is entered.)

11:34<sup>AM</sup> 12/25

1234  
NEW PASSWORD

7 Press **OK** **▶**.

- A beep sounds.
- To return to the standby mode, press **EXIT**.

Please write down your password. If you forget your password, consult your nearest Panasonic service centre.

- If you change the password back to “1111”, you will not be prompted to enter a password when you set Dial Lock (p. 55) or Call Restriction (p. 56).



# For Optional Multi-Portable Unit Users ➔

You can register and operate up to 4 portable units at the base unit.

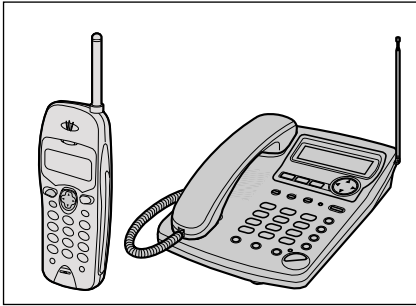

**KX-TC1170ALN**

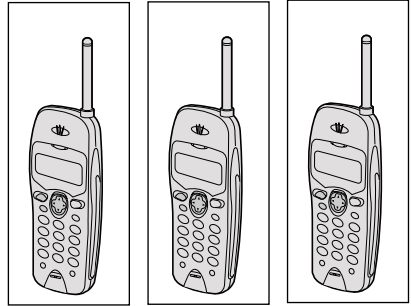

**Optional Multi-Portable Units**

## **Important:**

The functions of the optional portable unit are the same as the original portable unit.

The optional portable unit model number is KX-TCA391ALN.

When using two or more portable units, the following operation's features will be different. For details, see pages 68 to 71.

- Intercom between the portable unit and base unit
- Transferring outside calls

- All of the portable units ring when calls are received.
- When one of the portable units is in use or in the intercom mode, other portable units can not be used.
- Intercom between two portable units is not possible.

## ➔ For Optional Multi-Portable Unit Users

### Registering Optional Portable Units **Base Unit & Portable Unit**

Registration is necessary for portable units. You can register up to 4 portable units at the base unit. The model number of the optional portable unit is KX-TCA391ALN. The included portable unit is pre-registered at the factory and assigned the portable unit number 1.

A portable unit will be assigned the number at registration. Only one portable unit can be registered at a time.

You can not assign the same number to more than one portable unit. To confirm the portable unit number, place the portable unit on the charger.

**Make sure that the portable unit and base unit are in the standby mode. Registration must be completed within 1 minute.**

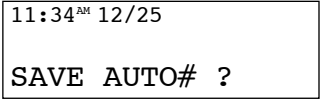
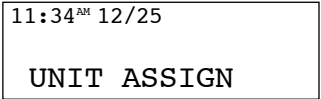
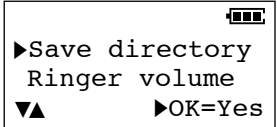
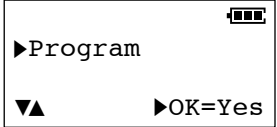
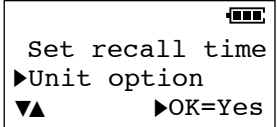
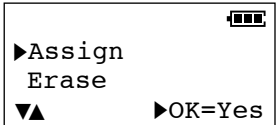
- 1 Base unit:**  
Press **FUNCTION/EDIT** until 2 beeps sound.  

- 2** Press **\***.
  - The IN USE indicator flashes.
- 3 Portable unit:**  
Press **FUNCTION/EDIT**.  

- 4** Press **▼** or **▲** repeatedly until the arrow points to "Program", then press **▶ OK** (Yes key).  

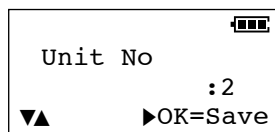
- 5** Press **▼** or **▲** repeatedly until the arrow points to "Unit option", then press **▶ OK** (Yes key).  

- 6** While "Assign" is at the arrow, press **▶ OK** (Yes key).  



- 7 Press **▼** or **▲** repeatedly until the desired portable unit number (1 to 4) is displayed.  
(Ex. "2" is selected.)



- The selected number is displayed.

- 8 Press **▶** **OK** (Save key).

- A beep sounds on the base unit and portable unit.
- The IN USE indicator on the base unit goes out.

- 9 Press **EXIT/CH** to return to the standby mode.

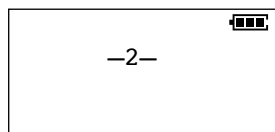

- The portable unit number (1 to 4) will be displayed on the portable unit.

- You can exit the programming mode any time by pressing **EXIT/CH**.
- If 3 beeps sound and the display shows "save error", place the portable unit on the charger. Start again from step 1.
- When you want to change the portable unit number, erase the previous number. Then restart from step 1.

## To erase the portable unit number

1. Press **FUNCTION/EDIT** on the portable unit.
  2. Press **▼** or **▲** repeatedly until the arrow points to "Program", then press **▶** **OK** (Yes key).
  3. Press **▼** or **▲** repeatedly until the arrow points to "Unit option", then press **▶** **OK** (Yes key).
  4. Press **▼** or **▲** repeatedly until the arrow points to "Erase", then press **▶** **OK** (Yes key).
    - The selected number is displayed.
  5. Press **▶** **OK** (Yes key).
    - A beep sounds.
    - To return to the standby mode, press **EXIT/CH**.
- You can exit the programming mode any time by pressing **EXIT/CH**.

## ➔ For Optional Multi-Portable Unit Users

# Intercom Between the Portable Unit(s) and Base Unit

*Portable Unit* *Base Unit*

A 2-way intercom is available between one of the portable units and base unit when another portable unit is not in use.

## Paging a portable unit from the base unit

The base unit user can page one of the portable units by using the portable unit number.

### 1 Base unit:

Lift the handset and press **LOCATOR/INTERCOM**. Then enter the desired portable unit number (1 to 4) within 2 seconds.

#### To page all the portable units:

Lift the handset and press **LOCATOR/INTERCOM**.

- The paged portable unit(s) beeps for 1 minute.
- To stop paging, place the handset on the cradle.

### 2 Portable unit:

Press **INTERCOM** to answer.

### 3 Base unit:

Talk into the handset.

### 4

To end the intercom:  
Place the handset on the cradle.  
OR  
Press **INTERCOM** on the portable unit.

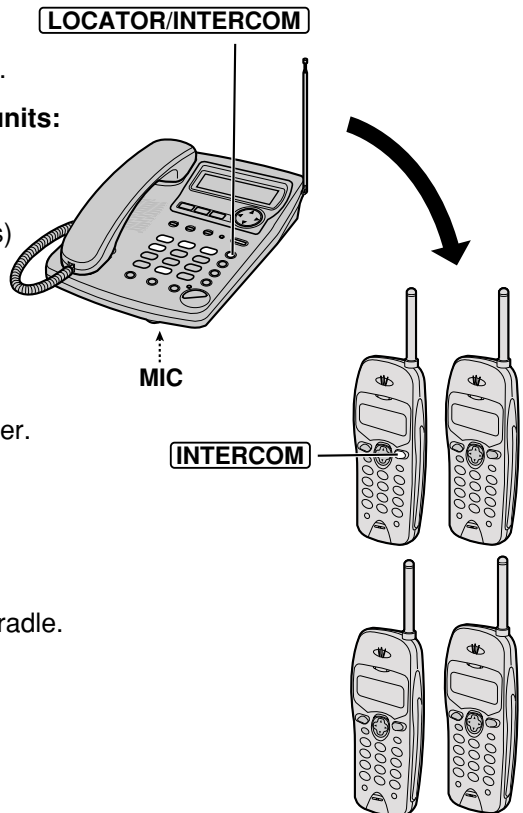

- In step 1, if you don't press **LOCATOR/INTERCOM** within about 5 seconds after lifting the handset, the line will be put on hold (p. 24).



- When paging a portable unit, if you decide you want to page another portable unit, you can page it by pressing the desired portable unit number. You can page all the portable units by pressing **0**.
- In step 1, the base unit user can also page by pressing **LOCATOR/INTERCOM** directly. You do not need to lift the handset.
  - If the portable unit user does not answer, press **LOCATOR/INTERCOM** to stop paging.
  - If the portable unit user answers, talk into the **MIC**.  
To end the intercom from the base unit, press **LOCATOR/INTERCOM**.
- In step 1, if you do not enter the portable unit number after pressing **LOCATOR/INTERCOM** within 2 seconds, all of the portable units will be paged.
- If 6 beeps sound and paging stops in step 1, the entered number has not been registered.

**Paging the base unit from a portable unit:** See page 58.

## ➔ For Optional Multi-Portable Unit Users

### Transferring Calls Using the Intercom **Portable Unit** **Base Unit**

The intercom can be used during a call.

This feature enables you to transfer a call between the base unit and a portable unit.

#### From the base unit to a portable unit

- 1 Base unit:**  
During a call, press **HOLD/RINGER** and **LOCATOR/INTERCOM**. Then enter the desired portable unit number (**1** to **4**) within 2 seconds.

##### To page all the portable units:

Press **LOCATOR/INTERCOM**.

- The call is put on hold and the paged portable unit(s) beeps for 1 minute.
- If the portable unit user does not answer:
  - for the handset, press **HOLD/RINGER**.
  - for the speakerphone, press **SP-PHONE**.

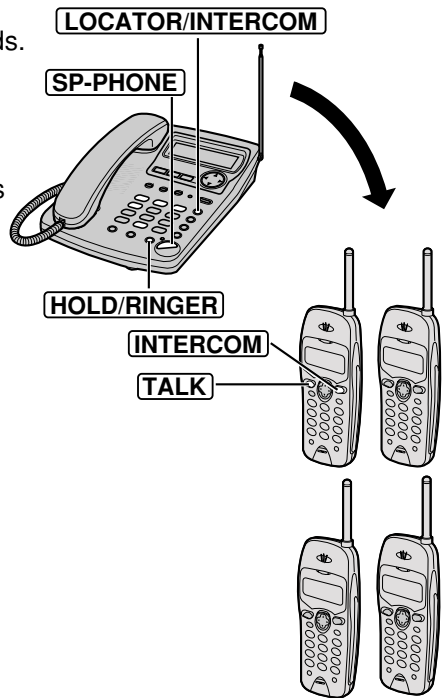

- 2 Portable unit:**  
Press **INTERCOM** to answer the page.

- 3 Portable unit:**  
To answer the call, press **TALK**.
  - The transfer is completed.

- When paging a portable unit, if you decide you want to page another portable unit, you can page it by pressing the desired portable unit number. You can page all the portable units by pressing **0**.
- In step 1, if you do not enter the portable unit number after pressing **LOCATOR/INTERCOM** within 2 seconds, all of the portable units will be paged.
- If 6 beeps sound then paging stops in step 1, the entered number has not been registered.

**From a portable unit to the base unit:** See page 60.

## Transferring Calls from One Portable Unit to Another **Portable Unit**

Transferring a call is available between one portable unit and another one. (Ex. Portable unit 1 is transferring a call to portable unit 2.)

### 1 **Portable unit 1:**

During a call, press **INTERCOM**. Then enter the desired portable unit number (**1** to **4**) within 2 seconds.

- The call is put on hold and the paged portable unit beeps for 1 minute.\*
- The paging and paged portable unit numbers are displayed on each unit.

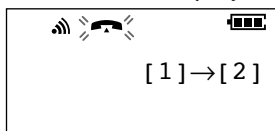

- If the portable unit user does not answer, press **TALK**.

### 2 **Portable unit 2:**

When the unit beeps, press **TALK** to answer the call.

- The transfer is completed.

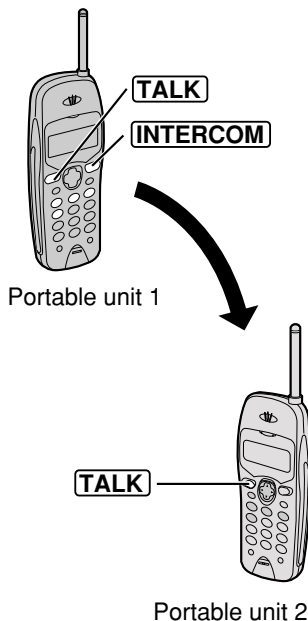

\* The paged portable unit beeps softly for 30 seconds. Then it will beep loudly for another 30 seconds.

- In step 1, if you do not enter the portable unit number after pressing **INTERCOM** within 2 seconds, the base unit will be paged.
- When paging a portable unit, if you decide you want to page another portable unit, you can page it by pressing the desired portable unit number. You can page the base unit by pressing **0**.
- If the paged portable unit user does not answer in 1 minute, the call will be put on music hold at the base unit. To release the hold, see page 24.
- Intercom between two portable units is not possible.

# Wall Mounting

---

## Base unit

The base unit can be mounted on a wall.

- 1 Pull down the handset hook until it locks, **so the tab holds the handset.**



- 2 Connect the AC adaptor.

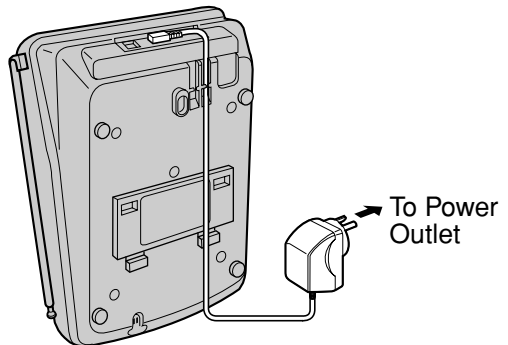

- 3 Tuck the telephone line cord inside the wall mounting adaptor.

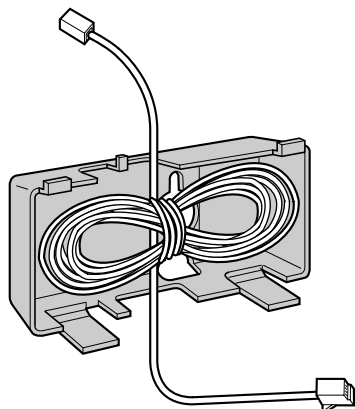





- 4
- ① Insert the tabs of the wall mounting adaptor into the “WALL” openings.
  - ② Push the adaptor in the direction of the arrow.
    - “UP WALL” should face upward.

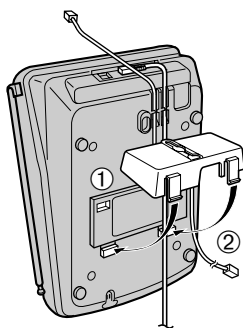

- 5
- Install screws using the wall template below. Connect the telephone line cord. Mount the unit, then slide down.
- Extend the antenna fully.

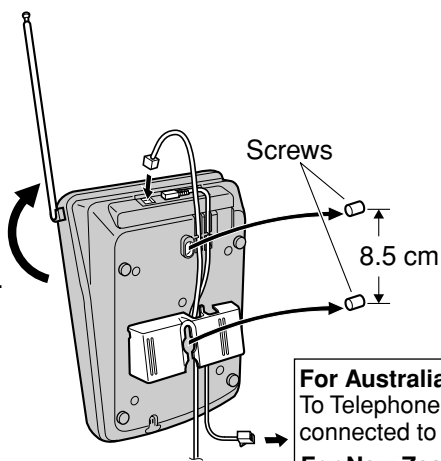

**For Australia**  
To Telephone Plug  
connected to Socket

**For New Zealand**  
To Single-Line  
Telephone Jack

To temporarily set the handset down during a conversation, place it as shown here.

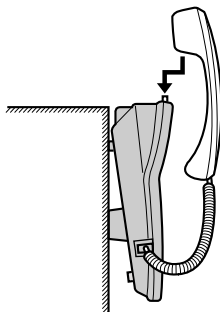

### Wall Template

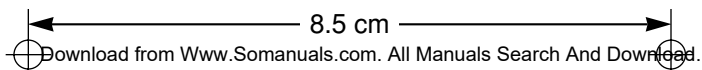

## ➔ Wall Mounting

---

### Charger

The charger can be wall mounted.  
Install screws using the wall template below. Connect the AC adaptor.  
Mount the charger, then slide it down.

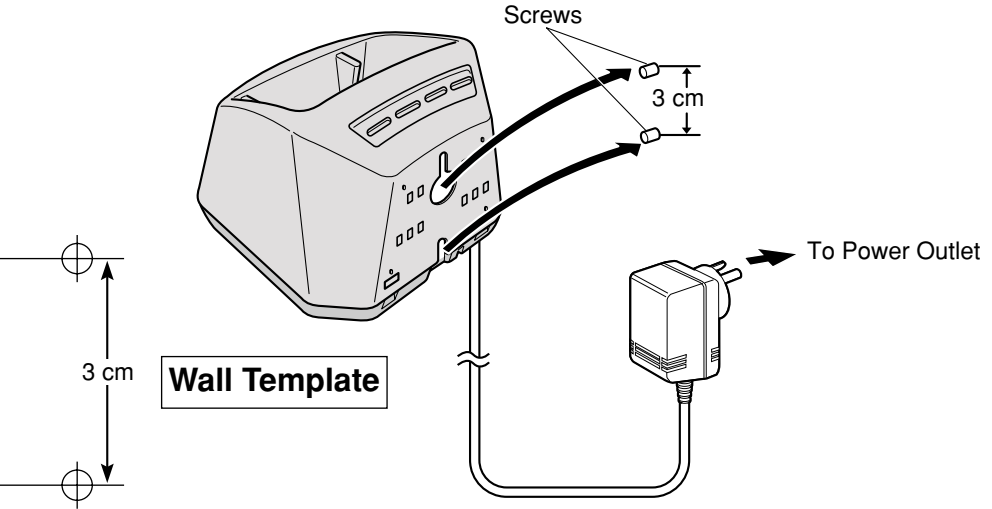

## Battery Replacement

---

If “Recharge battery” is displayed and/or “” flashes after being fully charged, replace the battery with a new Panasonic P-P301 (KX-A36A) battery.

To avoid memory loss, replace within 3 minutes.

- 1 Remove the cover by sliding while pressing the arrow.
- 2 Replace the battery, and close the cover.
- 3 Make sure to charge the new battery for about 10 hours in order to display the battery strength prompt correctly (p. 12).

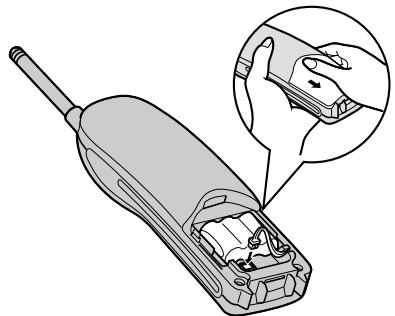

# Before Requesting Help



Problem	Remedy
The unit does not work.	<ul style="list-style-type: none"><li>• Check the settings (p. 10–18).</li><li>• Charge the battery fully (p. 12).</li><li>• Clean the charge contacts and charge again (p. 13).</li><li>• Install the battery properly (p. 74).</li><li>• Place the portable unit on the charger and unplug the AC adaptor of the base unit to reset. Plug in, then try again.</li><li>• Re-install the battery within 3 minutes to avoid memory loss and place the portable unit on the charger. Then try again.</li><li>• The portable unit number has been cleared or has not been registered. Register the portable unit (p. 66).</li><li>• This unit is not designed to be used with rotary (pulse dialling) services.</li></ul>
“Out of range” is displayed and an alarm tone sounds.	<ul style="list-style-type: none"><li>• The portable unit is too far from the base unit. Move closer and try again.</li><li>• Place the portable unit on the charger and try again.</li><li>• Plug in the AC adaptor of the base unit.</li><li>• Extend the antennas fully.</li><li>• Another portable unit is in use.</li></ul>
“Not available” is displayed and busy tones sound when you press <b>TALK</b> .	<ul style="list-style-type: none"><li>• The base unit is in use.</li></ul>
“LINE BUSY” is displayed.	<ul style="list-style-type: none"><li>• While the portable unit is engaged in an outside call. Wait until the IN USE indicator light goes out.</li></ul>
You cannot dial.	<ul style="list-style-type: none"><li>• The unit is in the dial lock mode. To cancel, see page 56.</li><li>• The dialled number is restricted. To cancel, see page 57.</li></ul>

## ➔ Before Requesting Help



Problem	Remedy
Static, sound cuts in/out, fades. Interference from other electrical units.	<ul style="list-style-type: none"><li>• Locate the portable unit and the base unit away from other electrical appliances (p. 3).</li><li>• Move closer to the base unit.</li><li>• Extend the antennas fully.</li><li>• Press <b>EXIT/CH</b> to select a clearer channel.</li></ul>
The portable unit does not ring.	<ul style="list-style-type: none"><li>• The ringer volume is set to OFF. Set to HIGH or LOW (p. 14).</li></ul>
The base unit does not ring.	<ul style="list-style-type: none"><li>• The ringer volume is set to OFF. Press <b>HOLD/RINGER</b> while the unit is in the standby mode (p. 15).</li></ul>
You cannot program items, such as the recall time setting.	<ul style="list-style-type: none"><li>• Programming is not possible while the unit is in the talk, speakerphone, intercom mode or when viewing the Caller List/directory list.</li><li>• Do not pause for over 60 seconds while storing.</li><li>• Move closer to the base unit.</li></ul>
Previously programmed information is erased.	<ul style="list-style-type: none"><li>• If a power failure occurs, programmed information may be erased. Reprogram if necessary.</li></ul>
You cannot store a name and phone number in the directory or cannot store a phone number in speed dial memory or in the one-touch auto dial button.	<ul style="list-style-type: none"><li>• You cannot store an item in the directory while the unit is in the talk or intercom mode.</li><li>• You cannot store a phone number in speed dial memory or a phone number in the one-touch auto dial button while the unit is in the speakerphone, talk or intercom mode.</li><li>• Do not pause for over 60 seconds while storing.</li></ul>



<b>Problem</b>	<b>Remedy</b>
While programming or searching, the unit starts to ring and stops the program/search.	<ul style="list-style-type: none"><li>• To answer the call, lift the handset or press <b>(TALK)</b> or <b>(SP-PHONE)</b>. Start again from the beginning after hanging up.</li></ul>
The display goes to the standby mode while viewing the Caller List/directory list.	<ul style="list-style-type: none"><li>• Do not pause for over 60 seconds while searching.</li></ul>
The unit does not display the caller's phone number.	<ul style="list-style-type: none"><li>• Other telephone equipment may be interfering with your phone. Disconnect it and try again.</li><li>• Other electrical appliances connected to the same outlet may be interfering with the Caller ID information.</li><li>• Telephone line noise may be affecting the Caller ID information.</li><li>• Some PABX do not support Caller ID services.</li></ul>
<b>(LOCATOR/INTERCOM)</b> does not function.	<ul style="list-style-type: none"><li>• The portable unit is too far from the base unit.</li><li>• The portable unit is engaged in an outside call. Wait until the IN USE indicator light goes out.</li><li>• The portable unit number has been cleared or has not been registered. Register the portable unit number (p. 66).</li></ul>
You cannot redial the last number dialled.	<ul style="list-style-type: none"><li>• If the last number dialled was more than 32 digits long, the number will not be redialled.</li><li>• <b>(REDIAL/PAUSE)</b> has a double function as either redial or pause. It will redial the last number dialled, if pressed at the outset of a call (p. 21, 24). If another number has been dialled first, it will operate as a pause button (p. 62).</li></ul>

## ➔ Before Requesting Help

---

Problem	Remedy
You cannot register the portable unit in the base unit.	<ul style="list-style-type: none"><li>• Charge the optional portable unit on the charger for about 10 hours before initial use.</li><li>• Another portable unit is in use.</li></ul>
“Recharge battery” is displayed, “  ” flashes or the unit beeps intermittently.	<ul style="list-style-type: none"><li>• Charge the battery fully (p. 12).</li></ul>
You charged the battery fully, but “Recharge battery” is still displayed and/or “  ” continues to flash.	<ul style="list-style-type: none"><li>• Clean the charge contacts and charge again (p. 13).</li><li>• Install a new battery (p. 74).</li></ul>
The CHARGE indicator light on the charger does not go out while charging.	<ul style="list-style-type: none"><li>• This is normal.</li></ul>
The call is disconnected.	<ul style="list-style-type: none"><li>• If a power failure occurs while using the portable unit or speakerphone, the call is disconnected. You can continue the call while using the base unit handset.</li></ul>

### **For New Zealand Customers**

Panasonic New Zealand operates a toll free customer Support Centre. Please phone 0800 Panasonic (0800 726276) for assistance.

# Safety Instructions



Take special care to follow the safety suggestions listed below.

## Safety

- 1) The unit should be connected to a power supply only of the type described in the operating instructions or as marked on the unit.
- 2) When left unused for a long period of time, the unit should be unplugged from the household AC outlet.
- 3) To minimize the possibility of lightning damage when you know that a thunderstorm is coming, we recommend that you:
  - a) Unplug the telephone line cord from the phone jack.
  - b) Unplug the power supply cord from the AC power outlet.

## Installations

### Environment

- 1) Do not use this unit near water— for example, near a bathtub, washbowl, sink, etc. Damp basements should also be avoided.
- 2) The unit should be kept away from heat sources such as radiators, kitchen range, etc. It also should not be placed in rooms where the temperature is less than 5°C or greater than 40°C.
- 3) The AC adaptor is used as the main disconnect device, ensure that the AC outlet is located/installed near the unit and is easily accessible.

### Placement

- 1) Do not place heavy objects on top of this unit.
- 2) Care should be taken so that objects do not fall onto, and liquids are not spilled into the unit. Do not subject this unit to excessive smoke, dust, mechanical vibration or shock.
- 3) Place the unit on a flat surface.

### For best performance

- 1) If noise prevents the conversation from being understood at the portable unit, approach the base unit to lessen the noise.
- 2) The portable unit should be used at the HIGH volume setting when the reception tone is difficult to hear.
- 3) The portable unit should be fully recharged on the charger when “Recharge battery” is displayed and/or “” flashes.
- 4) The portable unit antenna should not be touched during use because of its high sensitivity.
- 5) The maximum calling distance may be shortened when the unit is used in the following places: Near obstacles such as hills, tunnels, undergrounds, near metal objects such as wire fences, etc.

## ➡ Safety Instructions

---

### **WARNING:**

TO PREVENT FIRE OR SHOCK HAZARD, DO NOT EXPOSE THIS PRODUCT TO RAIN OR ANY TYPE OF MOISTURE.

When a failure occurs which result in the internal parts becoming accessible, disconnect AC adaptor immediately and return this unit to the place of purchase or service centre.

If there is any trouble, disconnect the unit from the telephone line and connect a known working phone. If the known working phone operates properly, do not reconnect the unit to the telephone line until the trouble has been repaired. If the known working phone does not operate properly, consult your telephone company.

This equipment has been tested and found to comply with AS/NZS 3548: 1995 limits for electromagnetic interference. Any modifications to any part of the system or to any peripherals may void the EMC compliance of the system or the peripherals.

This equipment will be inoperable if mains power fails.

The earcaps on the handset and portable unit are magnetised and may retain metallic objects.



# Important Information



## Instructions to customer (for Australia only)

### Installation

Attached to this apparatus is an approval label. This label is evidence that it is a "Permitted Attachment" which has been authorised to be connected to your telephone service.

Conditions relating to connection and operation of this Permitted Attachment are contained in Telecommunications General By-Law 220 (5). You are authorised to install this Permitted Attachment yourself by plugging it into the line socket of any regular telephone. You may connect it in place of your existing telephone or to any spare telephone socket installed in your premises.

To disconnect your existing telephone you must first remove its plug from the line socket. You can then insert the plug of your Permitted Attachment into the socket and use your equipment.

If the plug of your existing telephone cannot be readily removed, you will have to remove the screw securing it. To do this proceed as follows:

1. Loosen screw "A" sufficiently to remove the socket cover. (See Fig. 1.)
2. Remove screw "B" and withdraw the plug. (See Fig. 2.)
3. Replace screw "B". (See Fig. 3.) Ensure that it screws completely into the socket recess. (If the screw is too long, increase the hole depth or replace the screw with one 5 mm shorter.)
4. Replace socket cover and tighten screw "A". (See Fig. 4.)

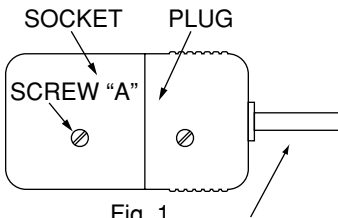

Fig. 1

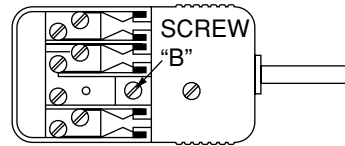

Fig. 2

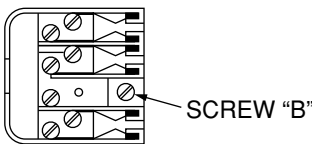

Fig. 3



Fig. 4

TELEPHONE CORD  
(Connect to the PLUG  
as shown in Fig. 1.)

## Important Information

---

If you are satisfied with the operation of your telephone service after plugging in your Permitted Attachment, your installation is completed.

You will be unable to connect this Permitted Attachment if your telephone service consists only of a wall phone or an old style telephone which is not connected by means of a modern plug and socket. In such cases a new socket will need to be installed.

Should the Permitted Attachment not operate when plugged into a socket, it is either faulty or unsuitable for operation with your telephone service. It should be returned to the store where purchased.

### **Service difficulties**

If at any time a fault occurs on your telephone service carry out the following checks before you call for service:

- Disconnect the Permitted Attachment and try using the service with the normal telephone.
- If the telephone service then operates satisfactorily, the fault is in your Permitted Attachment. Leave the Permitted Attachment disconnected and report the fault to its supplier or agent to arrange for repair.
- If when using the telephone the service is still faulty, report the fault to "Service Difficulties and Faults" for attention.

You are required to keep this Permitted Attachment in good working order while it is connected to your telephone service. Its construction or internal circuit must not be modified in any way without permission.

### **WARNING**

This cordless telephone system does not incorporate provision for secrecy of conversations. Appropriately tuned radio equipment and other cordless telephone systems in close proximity may be used by a third party to monitor and possibly interrupt conversations in progress when this system is on radio operation.

---

### **For New Zealand Users Only**

The grant of a Telepermit for any item of terminal equipment indicates only that Telecom has accepted that the item complies with minimum conditions for connection to its network. It indicates no endorsement of the product by Telecom, nor does it provide any sort of warranty. Above all, it provides no assurance that any item will work correctly in all respects with another item of Telepermitted equipment of a different make or model, nor does it imply that any product is compatible with all of Telecom's network services.

This equipment shall not be set to make automatic calls to the Telecom "111" Emergency Service.

#### **WARNING NOTICE:**

No "111" or other calls can be made from the portable unit this devices during a mains power failure.

- This cordless telephone system does not incorporate provision for secrecy of conversations. Appropriately tuned radio equipment and other cordless telephone systems in close proximity may be used by a third party to monitor and possibly interrupt conversations in progress when this system is on radio operation.

**Kyushu Matsushita Electric Co., Ltd.**

1-62, 4-chome, Minoshima, Hakata-ku, Fukuoka 812-8531, Japan

Printed in Malaysia

**PQQX12814ZA-BM** SM0800MK0

Download from [Www.Somanuals.com](http://Www.Somanuals.com). All Manuals Search And Download.

## Free Manuals Download Website

<http://myh66.com>

<http://usermanuals.us>

<http://www.somanuals.com>

<http://www.4manuals.cc>

<http://www.manual-lib.com>

<http://www.404manual.com>

<http://www.luxmanual.com>

<http://aubethermostatmanual.com>

Golf course search by state

<http://golfingnear.com>

Email search by domain

<http://emailbydomain.com>

Auto manuals search

<http://auto.somanuals.com>

TV manuals search

<http://tv.somanuals.com>