

Operating Instructions

Remote Operation Panel AW-CB400N

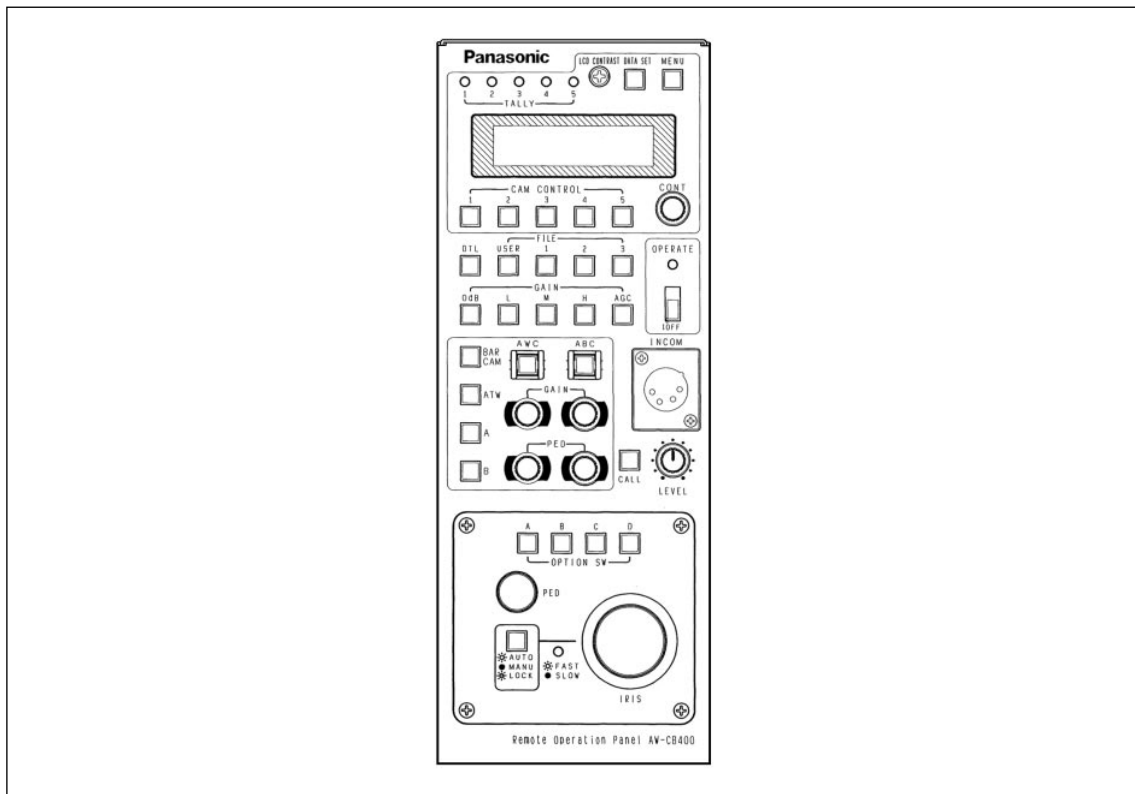

Panasonic®

Before attempting to connect, operate or adjust this product,
please read these instructions completely.

Safety precautions



The lightning flash with arrowhead symbol, within an equilateral triangle, is intended to alert the user to the presence of uninsulated "dangerous voltage" within the product's enclosure that may be of sufficient magnitude to constitute a risk of electric shock to persons.



The exclamation point within an equilateral triangle is intended to alert the user to the presence of important operating and maintenance (service) instructions in the literature accompanying the appliance.

For CANADA

This class A digital apparatus complies with Canadian ICES-003.

Cet appareil numérique de la classe A est conforme à la norme NMB-003 du Canada.

WARNING:

TO REDUCE THE RISK OF FIRE, ELECTRIC SHOCK OR PRODUCT DAMAGE, DO NOT EXPOSE THIS EQUIPMENT TO RAIN OR MOISTURE, DRIPPING OR SPLASHING AND THAT NO OBJECTS FILLED WITH LIQUIDS, SUCH AS VASES, SHALL BE PLACED ON THE EQUIPMENT.

WARNING:

TO PREVENT INJURY, THIS APPARATUS MUST BE SECURELY ATTACHED TO THE FLOOR/WALL IN ACCORDANCE WITH THE INSTALLATION INSTRUCTIONS.

CAUTION:

TO REDUCE THE RISK OF FIRE OR SHOCK HAZARD AND ANNOYING INTERFERENCE, USE ONLY THE RECOMMENDED ACCESSORIES.

FCC Note:

This device complies with Part 15 of the FCC Rules. To assure continued compliance follow the attached installation instructions and do not make any unauthorized modifications.

This equipment has been tested and found to comply with the limits for a class A digital device, pursuant to Part 15 of the FCC Rules. These limits are designed to provide reasonable protection against harmful interference when the equipment is operated in a commercial environment. This equipment generates, uses, and can radiate radio frequency energy and, if not installed and used in accordance with the instruction manual, may cause harmful interference to radio communications. Operation of this equipment in a residential area is likely to cause harmful interference in which case the user will be required to correct the interference at their own expense.

CAUTION:

DO NOT INSTALL OR PLACE THIS UNIT IN A BOOKCASE, BUILT-IN CABINET OR ANY OTHER CONFINED SPACE IN ORDER TO MAINTAIN ADEQUATE VENTILATION. ENSURE THAT CURTAINS AND ANY OTHER MATERIALS DO NOT OBSTRUCT THE VENTILATION TO PREVENT RISK OF ELECTRIC SHOCK OR FIRE HAZARD DUE TO OVERHEATING.

Note:

The rating plate (serial number plate) is on the bottom of the unit.

The socket outlet shall be installed near the equipment and easily accessible or the mains plug or an appliance coupler shall remain readily operable.

A warning that an apparatus with CLASS I construction shall be connected to a MAINS socket outlet with a protective earthing connection.

 indicates safety information.

IMPORTANT SAFETY INSTRUCTIONS

Read these operating instructions carefully before using the unit. Follow the safety instructions on the unit and the applicable safety instructions listed below. Keep these operating instructions handy for future reference.

- 1) Read these instructions.
- 2) Keep these instructions.
- 3) Heed all warnings.
- 4) Follow all instructions.
- 5) Do not use this apparatus near water.
- 6) Clean only with dry cloth.
- 7) Do not block any ventilation openings. Install in accordance with the manufacturer's instructions.
- 8) Do not install near any heat sources such as radiators, heat registers, stoves, or other apparatus (including amplifiers) that produce heat.
- 9) Do not defeat the safety purpose of the polarized or grounding-type plug. A polarized plug has two blades with one wider than the other. A grounding-type plug has two blades and a third grounding prong. The wide blade or the third prong are provided for your safety. If the provided plug does not fit into your outlet, consult an electrician for replacement of the obsolete outlet.
- 10) Protect the power cord from being walked on or pinched particularly at plugs, convenience receptacles, and the point where they exit from the apparatus.
- 11) Only use attachments/accessories specified by the manufacturer.
- 12) Use only with the cart, stand, tripod, bracket, or table specified by the manufacturer, or sold with the apparatus. When a cart is used, use caution when moving the cart/apparatus combination to avoid injury from tip-over. 
- 13) Unplug this apparatus during lightning storms or when unused for long periods of time.
- 14) Refer all servicing to qualified service personnel. Servicing is required when the apparatus has been damaged in any way, such as power-supply cord or plug is damaged, liquid has been spilled or objects have fallen into the apparatus, the apparatus has been exposed to rain or moisture, does not operate normally, or has been dropped.

 indicates safety information.

Contents

Introduction	4	Operating procedure	14
Accessories	4	Turning on the power	14
Precautions for use	5	Adjusting the cable compensation of each camera.....	14
Parts and their functions	6	Genlock adjustments for each camera	14
Front panel	6	Video adjustment of cameras	15
Rear panel	9	Menu settings	16
Connections	10	Operation method	16
When connecting a convertible camera directly	10	Items which can be selected on the camera setting display	17
When connecting the ROP in a system that includes pan/tilt heads, pan/tilt control panel and cable compensation unit	10	Items which can be selected on the remote operation panel setting display	19
Example of system configuration	11	How to mount the ROP in a rack	20
When connecting a camera directly	11	Joining the ROP to the AW-RP400 and mounting the joined-up units in a rack	20
When connecting the ROP in a system that includes pan/tilt heads, pan/tilt control panel and cable compensation unit	12	How to change the position of the connector panel	21
When the distance between the ROP and the pan/tilt control panel is more than 10 meters	13	Specifications	22

Introduction

This remote operation panel (ROP) enables up to five convertible cameras to be controlled. Menu items can be selected on the ROP's LCD display to set the functions of the cameras. The connection distance between the ROP and convertible cameras can be extended up to a maximum of 1000 meters. By connecting the ROP to the pan/tilt control panel using the cable supplied, the convertible cameras mounted on the pan/tilt heads can be controlled.

This Operating Instruction describes each apparatus as follows;

Pan/tilt control panel: **AW-RP400**
Pan/tilt head: **AW-PH400**
Cable compensation unit: **AW-RC400**

Note

When the remote operation panel is to be discarded at the end of its service life, ask a specialized contractor to dispose of it properly in order to protect the environment.

Accessories

Pan/tilt control panel (AW-RP400) connecting cable	1
Tally/INCOM connector (D-SUB 15-pin)	1
Rack-mounting adaptors	2
Join-up fixture	1
Mounting screws (M4 × 8 mm)	8
Join-up screws (stepped screws)	2
Joining sticker	2

Precautions for use

- **Handle the ROP carefully.**

Dropping the ROP or subjecting it to strong impact may give rise to malfunctioning or accidents.

- **Use the ROP in an ambient temperature of 14°F to 113°F (–10°C to +45°C).**

Using the ROP in cold places below 14°F (–10°C) or hot places above 113°F (45°C) may adversely affect its internal parts.

- **Turn off the power before connecting or disconnecting the cables.**

Be absolutely sure to turn off the power before connecting or disconnecting the cables.

- **Maintenance**

Wipe the ROP using a dry cloth. To remove stubborn dirt, dip a cloth into a diluted solution of kitchen detergent, wring it out well, and wipe the ROP gently.

<Caution>

- Avoid using benzine, paint thinners and other volatile fluids.
- If a chemical cleaning cloth is to be used, carefully read through the precautions for its use.

Parts and their function

■ Front panel

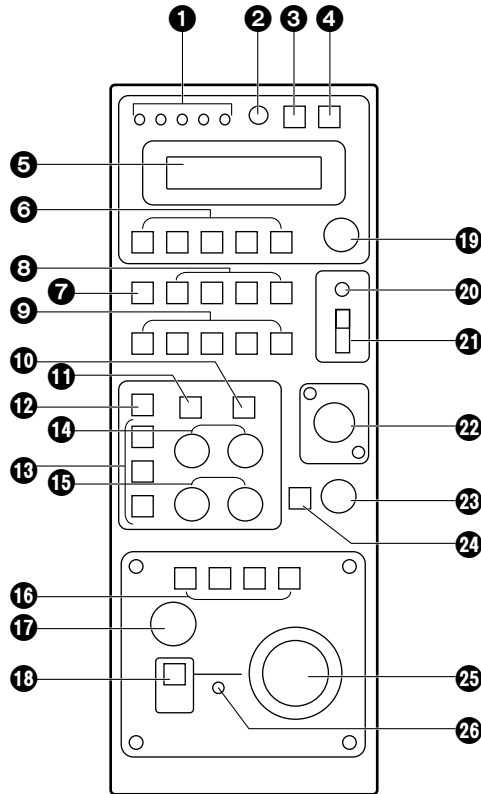

1 TALLY lamps [1] to [5]

When tally signals are supplied to the (23) tally/INCOM connectors [1] to [5] on the rear panel, the lamps with the numbers corresponding to those connectors light up. When tally signals are supplied to the tally connectors [1] to [5] of the pan/tilt control panel, if this control panel is connected to the ROP, the lamps with the numbers corresponding to those connectors also light up.

2 LCD CONTRAST control

Use this to adjust the contrast of the LCD panel.

3 DATA SET button

Press DATA SET button and (6) CAM CONTROL buttons [1] to [5] at the same time to synchronize the setting data stored in the cameras selected with the setting data stored in the ROP or vice versa. Press only DATA SET button to synchronize the setting data stored in all cameras connected to the ROP.

- In the case of the AW-E300, AW-E300A, AW-E600 or AW-E800A cameras, the data stored in the ROP is transferred to the cameras. In the case of the AW-E350, AW-E650, AW-E655 or AW-E750 cameras, the data stored in the cameras is transferred to the ROP. Data transfer takes two to three or so minutes.
- Press this button when the ROP is used for the first time, or when the camera is replaced.

4 MENU button

Press this to turn the setting menu ON or OFF.

5 LCD panel

This displays the current settings.

6 CAM CONTROL buttons [1] to [5]

If the cameras are connected directly to the ROP, the button lamps corresponding to numbers of the buttons selected light, and the selected cameras can be controlled by pressing buttons [1] to [5]. If the ROP is connected to the pan/tilt control panel for use, the cameras installed to the pan/tilt head which is connected to the pan/tilt control panel can be selected. The buttons corresponding to the selected numbers light, and selected cameras can be controlled. When the ROP is connected to the pan/tilt control panel, the camera selection function can be set to "From pan/tilt control panel only", "From ROP only" or "From both", depending on the setting selected by the pan/tilt control panel. For further details, refer to the instruction manual of the pan/tilt control panel.

Parts and their function

7 DTL button

Each time this is pressed, the detail is switched from ON to OFF or vice versa. While the detail is ON, the button lamp is lighted; while it is OFF, the button lamp is off. The setting while the detail is ON is set using the menu.

8 SCENE FILE buttons [USER/1/2/3]

Use these to select the scene files of the camera.

9 GAIN buttons [0dB/L/M/H/AGC]

Use these to set the camera gain.

The gain-up function can be set to one of four levels using the GAIN 0dB, L, M and H buttons.

The gain-up amount can be set for the L, M and H buttons each using the respective menus.

When the AGC button is pressed, AGC is activated, and the gain is adjusted automatically in accordance with the light quantity.

The maximum AGC gain can be set using the menu.

10 ABC button

Press this button to adjust the black balance automatically.

While the black balance is being adjusted, the button lamp flashes; when the adjustment is completed, it goes off. It lights if the black balance could not be adjusted.

- The ABC button does not work when color bars have been selected by the (12) BAR/CAM button (the button lamp is lighted).

11 AWC button

When this button is pressed while the A or B button among the (13) ATW/A/B buttons is selected, the white balance is automatically adjusted, and the adjustment is registered in the camera's AWC A or AWC B memory. While the white balance is being adjusted, the AWC button lamp flashes, and when it is adjusted properly, it goes off. It lights if the white balance could not be adjusted.

- The AWC button does not work when color bars have been selected by the (12) BAR/CAM button (the button lamp is lighted) or when the ATW button among the (13) ATW/A/B buttons is selected (the ATW button lamp is lighted).
- It may not be possible to adjust the white balance if the screen does not show an image with a white object.

12 BAR/CAM button

Use this to select the camera's video output signals.

Each time it is pressed, the camera signals are switched from color bar signals to video signals or vice versa.

While color bar signals are selected, the button lamp is lighted; while video signals are selected, it is off.

13 ATW/A/B buttons

Use these to select the white balance adjustment mode.

ATW: When the ATW button is pressed, the automatic adjustment mode is established for the white balance, and the ATW button lamp lights.

A: When the A button is pressed, the white balance registered in the camera's AWC A memory is established, and the A button lamp lights.

When the (11) AWC button is pressed after pressing the A button, the white balance is automatically adjusted and registered in the camera's AWC A memory.

B: When the B button is pressed, the white balance registered in the camera's AWC B memory is established, and the B button lamp lights.

When the (11) AWC button is pressed after pressing the B button, the white balance is automatically adjusted and registered in the camera's AWC B memory.

14 R/B GAIN dials

These enable the white balance to be adjusted manually after selecting the A or B button among the (13) ATW/A/B buttons and the white balance has been automatically adjusted by pressing the (11) AWC button.

When exercising control over the AW-E350, AW-E650, AW-E655 or AW-E750, the change of setting value in the dial's setting can be switched from "large" to "small" or vice versa by pressing the CONT dial.

15 R/B PED dials

These enable the black balance to be adjusted manually after the black balance has been automatically adjusted by pressing the (10) ABC button.

When exercising control over the AW-E350, AW-E650, AW-E655 or AW-E750, the change of setting value in the dial's setting can be switched from "large" to "small" or vice versa by pressing the CONT dial.

16 OPTION SW [A to D] buttons

Refer to "Menu settings" for details on the items which can be set in these OPTION SW buttons.

Parts and their function

17 PED dial

This enables the total pedestal of the cameras to be set. When exercising control over the AW-E350, AW-E650, AW-E655 or AW-E750, the change of setting value in the dial's setting can be switched from "large" to "small" or vice versa by pressing the CONT dial.

18 IRIS [AUTO/MANU/LOCK] button

Use this to select the method for adjusting the lens iris of the cameras selected by the CAM CONTROL buttons. Each time it is pressed, the setting is switched in the sequence of AUTO, MANU and LOCK.

AUTO: The cameras automatically adjust the lens iris in accordance with the light quantity, and the button lamp lights.

MANU: The lens iris is adjusted manually using the (25) IRIS dial. At this setting, the button lamp is off.

LOCK: The lens iris is locked at the manually adjusted setting. It cannot be adjusted even by turning the (25) IRIS dial. When the (25) IRIS dial is turned, the button lamp flashes to indicate that the lens iris cannot be adjusted.

When the ROP is connected to the pan/tilt control panel, the lens iris control can be set to "From pan/tilt control panel only", "From ROP only" or "From both", depending on the setting selected by the pan/tilt control panel. For further details, refer to the instruction manual of the pan/tilt control panel.

19 CONT dial

Use this for menu setting operations.

20 OPERATE lamp

When the (21) OPERATE switch is at ON, this lamp lights up green; when it is at OFF, the lamp is off.

21 OPERATE [OFF/ON] switch

Camera control is enabled by setting this switch to ON.

Note

When the ROP is connected to the pan/tilt control panel, camera control is not possible unless the OPERATE switch on the pan/tilt control panel is set to ON.

22 INCOM jack

The INCOM (inter-communication) headset is connected here.

23 LEVEL control

Use this to adjust the volume of the headset's receiver.

24 CALL button

When this button is pressed, the buzzer of the connected controller sounds, and the button lamp lights.

25 IRIS dial

The lens iris can be adjusted by turning this dial while the (18) IRIS [AUTO/MANU/LOCK] button is set to MANU.

The iris is opened by turning the dial clockwise and stopped by turning it counterclockwise.

By pressing the (19) CONT dial, the response speed can be switched from "fast" to "slow" or vice versa.

26 FAST/SLOW lamp

When the response speed of the (25) IRIS dial is at "fast", this lamp lights up; when it is at "slow", the lamp is off.

Parts and their function

■ Rear panel

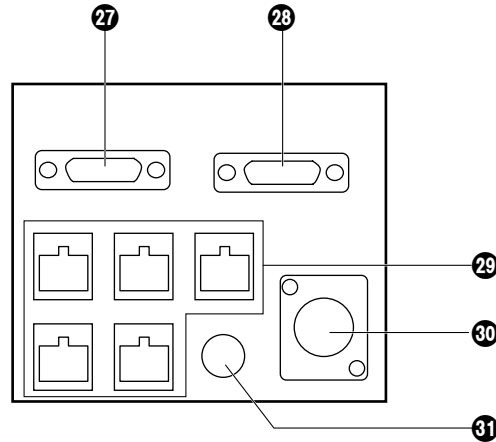

27 CONTROL OUT TO CONTROL PANEL connector

When connecting the pan/tilt control panel for operation, connect this connector to the CAMERA CONTROL IN FROM ROP connector on the pan/tilt control panel using the control panel's connecting cable. The cameras are then controlled through the pan/tilt control panel.

28 TALLY/INCOM connector

Connect this to the TALLY/INCOM connector on the video switcher or other units.
When the TALLY connector is set to the GND level, the (1) TALLY lamp lights. Do not apply a voltage in excess of 5V to this connector.

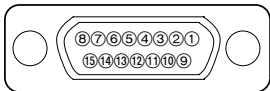

Pin layout as seen from the back panel of AW-CB400

Pin No.	Signal Name
1	TALLY1
2	TALLY2
3	TALLY3
4	TALLY4
5	TALLY5
6	TALLY GND
7	---
8	---
9	---
10	---
11	---
12	---
13	---
14	MIC +
15	MIC -
16	INCOM GND
17	SP -
18	SP +

Use the accessory tally/INCOM connector (D-SUB 15-pin) to connect the tally/INCOM signals to the system.
Connect a 4-wire INCOM system to the INCOM connector.

When the ROP has been connected to the pan/tilt control panel, the tally/INCOM functions of the ROP and the pan/tilt control panel will be executed if the tally/INCOM signals are connected to the ROP or the pan/tilt control panel.

29 CONTROL OUT TO CAMERA connectors [1] to [5]

Connect these to the convertible cameras.
Use the connecting cables (optional accessory) AW-CA50T8 or AW-CA50T9 + RS-422/RS-232C converter to connect these connectors to the I/F REMOTE connectors on the convertible cameras.

30 DC 12V IN socket

Connect the AW-PS505 AC adaptor (optional accessory) to this socket.
When the ROP is connected to the pan/tilt control panel using the pan/tilt control panel connecting cable, power will be supplied to the ROP from the pan/tilt control panel.

31 Grounding terminal

Connect this terminal to ground.

Connections

■ When connecting a convertible camera directly

- First, turn off the power of all the equipment before proceeding with the connections.
- Use the AW-PS505 for the AC adaptor of the ROP.
Connect the DC 12V OUT socket on the AW-PS505 to the DC 12V IN socket on the ROP using the DC cable provided with the AW-PS505.
- Use the AW-PS505 for the AC adaptor of the convertible camera.
Connect the DC 12V OUT socket on the AW-PS505 to the DC 12V IN socket on the convertible camera using AW-CA4T1.
- Connect the CONTROL OUT TO CAMERA connectors [1] to [5] on the ROP with the I/F REMOTE connectors on the convertible cameras through the connecting cables (optional accessory) AW-CA50T8 or AW-CA50T9 + RS-422/RS-232C converter.
The distance between the ROP and the AW-CA50T8 or AW-CA50T9 + RS-422/RS-232C converter can be extended up to a maximum of about 1000 meters using a 10Base-T (equivalent to UTP category 5) straight cable.

■ When connecting the ROP in a system that includes pan/tilt heads, pan/tilt control panel and cable compensation unit

- First, turn off the power of all the equipment before proceeding with the connections.
- Connect the CONTROL OUT TO CONTROL PANEL connector on the ROP with the CAMERA CONTROL IN FROM ROP connector on the pan/tilt control panel using the pan/tilt control panel connecting cable provided with the ROP.
- Power will be supplied to the ROP from the pan/tilt control panel.
- For details on how to connect the pan/tilt heads, pan/tilt control panel and cable compensation unit, refer to the instruction manual provided with these units.

Example of system configuration

■ When connecting a camera directly

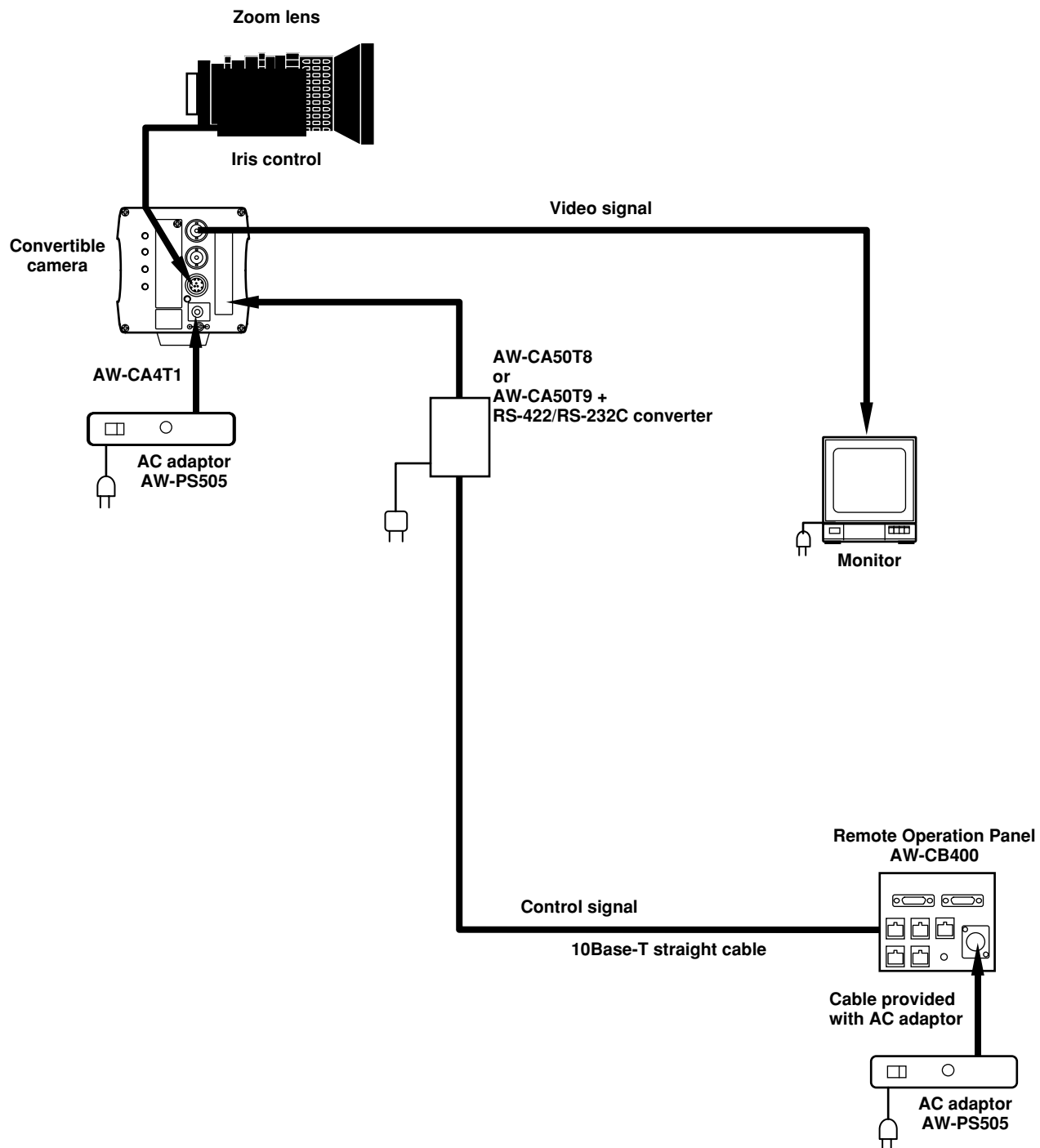

Example of system configuration

- When connecting the ROP in a system that includes pan/tilt heads, pan/tilt control panel and cable compensation unit

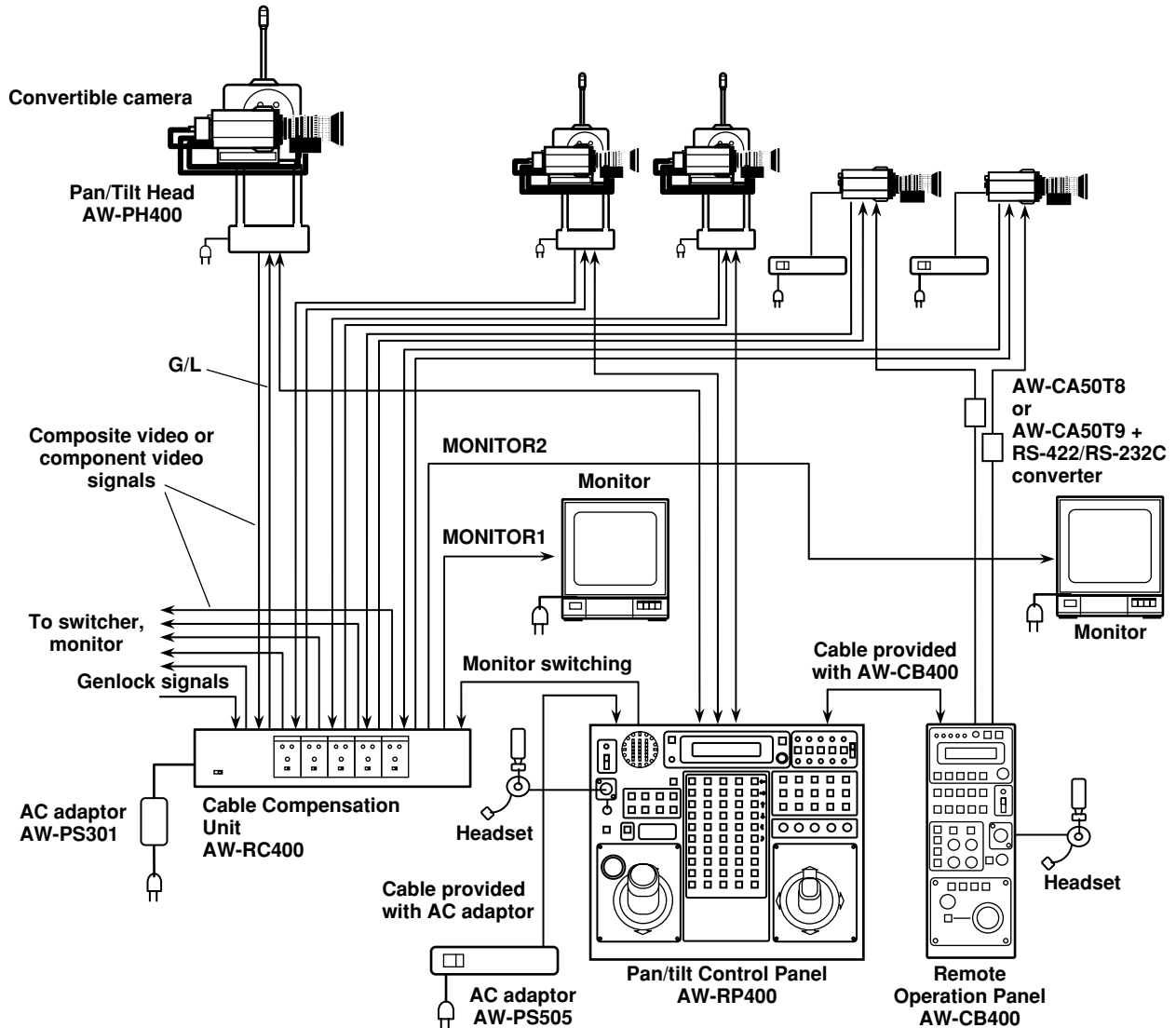

When a pan/tilt head system and cameras have been connected to the CONTROL OUT connectors on the pan/tilt control panel and the CONTROL OUT connectors with the corresponding numbers on the ROP, the camera control exercised by the pan/tilt head system connected to the CONTROL OUT connectors on the pan/tilt control panel takes priority, and the camera connected directly to the ROP cannot be controlled.

* For details on how to connect the pan/tilt heads and pan/tilt control panel, refer to the instruction manual provided with the pan/tilt control panel.

Example of system configuration

■ When the distance between the ROP and the pan/tilt control panel is more than 10 meters

The distance between the ROP and the pan/tilt control panel can be extended up to a maximum of about 1000 meters on the following condition using the provided cable (refer following specifications) and/or equivalent cables. (Prepare the cables of required length.)

- **Up to 50 meters:** Use the recommended AC adaptor for the power supply of the pan/tilt control panel.
- **More than 50 meters:** Supply DC 12V to the ROP and the pan/tilt control panel from the recommended AC adaptor. In this case, it is not necessary to connect +12V IN.

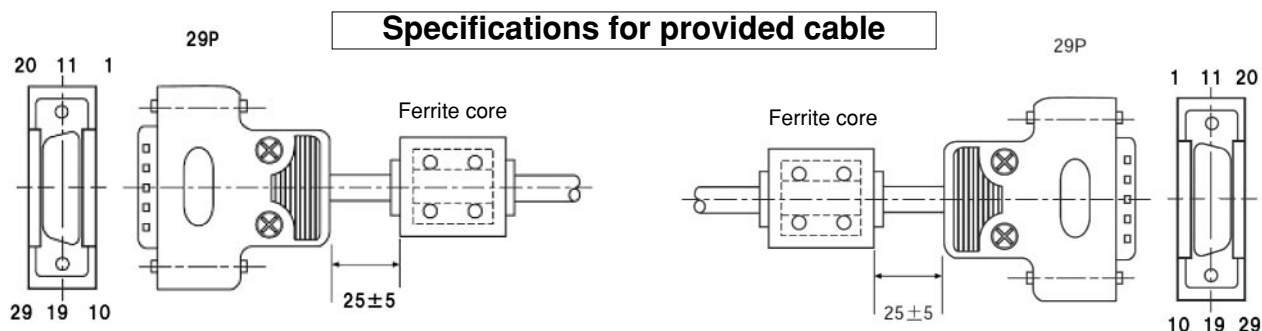

Use the twist pair cables.

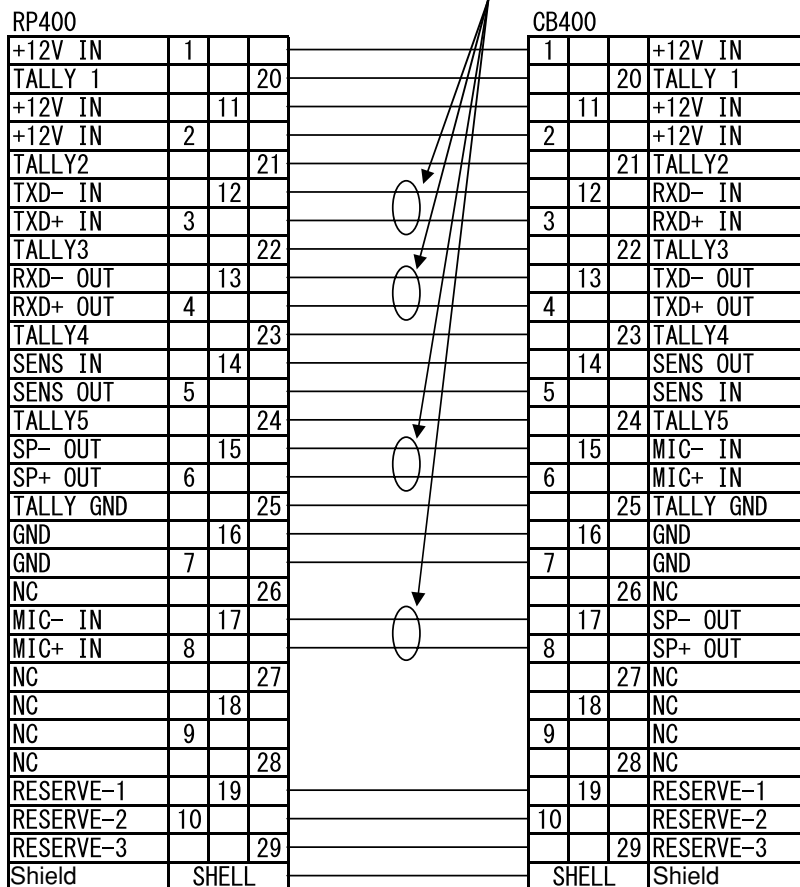

Connector used

Japan Aviation Electronics Industry, Ltd.
 Connector: D02-29PF-N-F0
 Contact: D02-22-26P-PKG100
 (For AWG 26 to 28)
 Case: DA-C4-J10

Connector used

Japan Aviation Electronics Industry, Ltd.
 Connector: D02-29SF-N-F0
 Contact: D02-22-26S-PKG100
 (For AWG 26 to 28)
 Case: DA-C4-J10

Operating procedure

■ Turning on the power

Turn on the power.

First set the power switch on the AC adaptor used for the ROP and the AC power switches on the cameras to ON, and set the OPERATE switch on the ROP to ON.

■ Adjusting the cable compensation of each camera

For details on providing cable compensation for the cameras, refer to the instruction manual provided with the cable compensation unit.

■ Genlock adjustments for each camera

If the cameras are to be used in the genlock mode, phase adjustment is required in order to adjust the phases between the cameras and other units. Genlock adjustment is not needed if genlock is not going to be used.

Horizontal phase adjustment

- ① Select the first camera to be adjusted by pressing the CAM CONTROL button.
- ② Press the MENU button, and display the camera setting menu on the LCD panel.
- ③ Turn the CONT dial, and display the G/L SETTING menu.
- ④ Push the CONT dial straight down, and display H PHASE on the bottom line of the LCD.
- ⑤ Observe the waveforms of the genlock signal (black burst signal or video signal (VBS)) and video signal output on an oscilloscope, and adjust the CONT dial in such a way that the horizontal phase is adjusted as shown in the figure below.

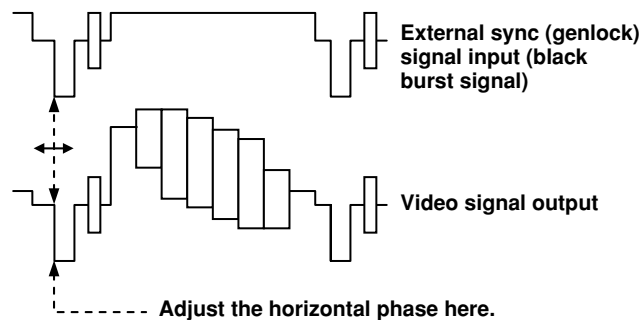
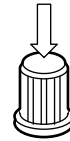

- ⑥ Select the next camera by pressing the CAM CONTROL button, and adjust the horizontal phase of the next camera. Repeat this for all the connected cameras.

Operating procedure

Sub carrier phase adjustment

- ① Select the first camera to be adjusted by pressing the CAM CONTROL button.
- ② Press the MENU button to display the menu on the LCD panel.
- ③ Turn the CONT dial to display the G/L SETTING menu.
- ④ Push the CONT dial straight down twice to display SC COARSE on the bottom line of the LCD. The sub carrier phase can now be adjusted coarsely by turning the CONT dial.
When the CONT dial is pushed three times, SC FINE appears, and the sub carrier phase can now be adjusted finely by turning the CONT dial.
- ⑤ Keep adjusting the SC COARSE and SC FINE phase so that the sub carrier (color) phase of the video signal output is aligned with the colors of the program output (split color bar output) of the video switcher or other unit that serves as the reference.
The color phase can be adjusted more accurately if a vectorscope is used.
- ⑥ Select the next camera by pressing the CAM CONTROL button, and adjust the sub carrier phase of the next camera.
Repeat this for all the connected cameras.

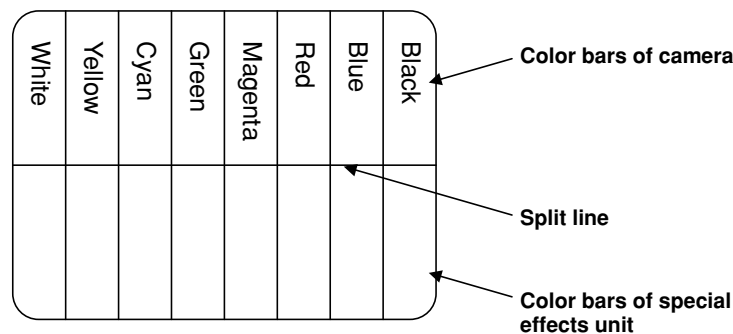

■ Video adjustment of cameras

This adjustment is performed when the pedestal of a multiple number of cameras is to be brought into alignment.

- ① Select the first camera to be adjusted by pressing the CAM CONTROL button.
- ② Set the lens iris to manual, and stop it down.
- ③ Use an oscilloscope or waveform monitor to adjust the pedestal level to correspond to the reference level using the total pedestal dial.
- ④ Select the next camera by pressing the CAM CONTROL button, and adjust the pedestal of the next camera. Repeat this for all the connected cameras.

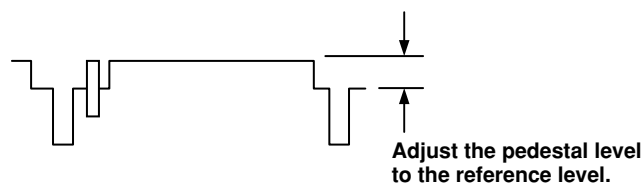

Menu settings

■ Operation method

The GAIN information appears first when the OPERATE switch is set to ON.

When the MENU button is pressed, the display changes in the sequence shown below, after which the display returns to the gain setting screen.

◇ Gain setting

```
GAIN          0dB
R:   0   B:   0
```



◇ Pedestal setting

```
PEDESTAL T:   0
R:   0   B:   0
```



◇ DTL setting (when SCENE FILE is set to the USER mode)

```
DETAIL H DETAIL
                15
```

◇ DTL setting (when 1, 2 or 3 is set for SCENE FILE)

```
DETAIL
                HIGH
```



◇ Camera settings

```
(Camera setting items)
```



◇ Remote operation panel settings

```
(ROP settings)
```



◇ LCD off

```
(LCD off)
```

① Gain setting

The gain of the camera selected by the CAM CONTROL button is set on this display.

The analog gain-up value appears on the right of the top line, and the gain information for the lighted GAIN button is displayed.

The R gain and B gain settings are shown on the bottom line.

When the R or B GAIN dial is turned, the R or B gain is incremented or decremented. The value which can be set differs depending on the camera concerned.

The values corresponding to white balance A and B can be stored in the memory. When the automatic adjustment mode (ATW among the ATW, A and B buttons) has been selected for the white balance, "--" appears on the display, and the gain cannot be set.

② Pedestal setting

The pedestal of the camera selected by the CAM CONTROL button is set on this display.

The total pedestal setting is shown on the top line, and the R pedestal and B pedestal settings on the bottom line.

When the R or B PED dial is turned, the R or B pedestal is incremented or decremented. The value which can be set differs depending on the camera concerned.

③ DTL setting

The horizontal detail and vertical detail of the camera selected by the CAM CONTROL button is set on these displays.

When USER is selected for SCENE FILE, any value from 0 to 63 can be set as the H DETAIL and V DETAIL level.

Press the CONT switch to switch between H and V.

When 1, 2 or 3 is set for SCENE FILE, use the CONT dial to switch between HIGH and LOW.

④ Camera settings

The detailed settings of the camera selected by the CAM CONTROL button are set on these displays.

Turn the CONT dial to select the setting item, and press it to display the settings on the bottom line. If the CONT dial is turned while the setting is displayed, the setting can be changed. Upon completion of the setting, press the CONT dial to clear the bottom line display, and another setting item can now be selected.

⑤ Remote operation panel settings

The controller settings are set on these displays.

Operation is the same as that for "④ Camera settings".

⑥ Exiting the setting menu

Press the MENU button to exit the setting menu.

Menu settings

■ Items which can be selected on the camera setting display

Item	Setting	Initial value
PICTURE LEVEL	-50 to +50	0
LIGHT PEAK/AVG	P50 to A50	0
LIGHT AREA	ALL, CENTER, TOP CUT, BTM CUT, L/R CUT	TOP CUT
SHUTTER	1/100, 1/250, 1/500, 1/1000, 1/2000, 1/4000, 1/10000, SYN-SCAN, ELC	OFF
SYNCHRO SCAN		
DIGITAL GAIN	0, 6, 12, 18, 24, 30dB	0dB
AGC MAX LEVEL	OFF, 6, 12, 18, 24, 30, N/Eye L, N/Eye H	
CHARGE TIME	2S, 1S, 1/2S, 1/4S, 1/8S, 1/15S, 1/30S, OFF, AUTO,	OFF
CHROMA LEVEL	-3 to +3	0
ATW SPEED	SLOW2, SLOW1, MIDDLE, FAST1, FAST2	MIDDLE
NEGA/POSI	POSI, NEGA	POSI
H PHASE	-206 to +49	0
SC COARSE	0°, 90°, 180°, 270°	0°
SC FINE	-511 to +511	0
COLOR BAR SET	0.0%, 7.5%	7.5%
DETAIL BAND	1 to 5	2
NOISE SUPPRESS	0 to 10	3
LEVEL DEPENDENT	0% to 25%	0%
DARK DETAIL	0 to 5	0
CHROMA DETAIL	0 to 15	0
DTL FLESH TONE	LOW, MID, HIGH	MID
CORNER DETAIL	OFF, ON	OFF
PRECISION DTL	OFF, ON	OFF
MATRIX B_Mg GAIN	-127 to +127	0
MATRIX B_Mg PHAS	-127 to +127	0
MATRIX Mg GAIN	-127 to +127	0
MATRIX Mg PHASE	-127 to +127	0
MATRIX Mg_R GAIN	-127 to +127	0
MATRIX Mg_R PHAS	-127 to +127	0
MATRIX R GAIN	-127 to +127	0
MATRIX R PHASE	-127 to +127	0
MATRIX R_YI GAIN	-127 to +127	0
MATRIX R_YI PHAS	-127 to +127	0
MATRIX YI GAIN	-127 to +127	0
MATRIX YI PHASE	-127 to +127	0
MATRIX YI_G GAIN	-127 to +127	0
MATRIX YI_G PHAS	-127 to +127	0

Menu settings

Item	Setting	Initial value
MATRIX G GAIN	-127 to +127	0
MATRIX G PHASE	-127 to +127	0
MATRIX G_Cy GAIN	-127 to +127	0
MATRIX G_Cy PHAS	-127 to +127	0
MATRIX Cy GAIN	-127 to +127	0
MATRIX Cy PHASE	-127 to +127	0
MATRIX Cy_B GAIN	-127 to +127	0
MATRIX Cy_B PHAS	-127 to +127	0
MATRIX B GAIN	-127 to +127	0
MATRIX B PHASE	-127 to +127	0
GAMMA	0.35 to 0.55	0.45
KNEE POINT	DYNAMIC, 88% to 98%	88%
WHITE CLIP	95% to 110%	110%
FLARE R	0 to 100	0
FLARE G	0 to 100	0
FLARE B	0 to 100	0
BLACK STRETCH	OFF, ON	OFF
CLEAN DNR	OFF, LOW, HIGH	OFF
3D-DNR	OFF, LOW, MID, HIGH	OFF
2D-LPF	OFF, LOW, HIGH	OFF
FIELD/FRAME	FIELD, FRAME	FIELD/FRAME
COMPONENT	R/G/B , Y/Pb/Pr, Y/C	Y/Pb/Pr
DIGITAL EXTENDER	OFF, ON	OFF
ZEBRA INDICATOR	OFF, ON	OFF
ZEBRA LEVEL	70% to 110%	
SAFETY ZONE	1, 2, 3, 4, 5, OFF	4
EVF OUTPUT	Y, CVBS	CVBS

* Concerning the camera setting items

The functions that can be controlled vary depending on the camera connected.

If a camera does not support a particular function, its setting will not take effect even if that function appears on the menu.

For details on the functions featured by a specific camera, refer to the camera's instruction manual.

Menu settings

■ Items which can be selected on the remote operation panel setting display

Item	Setting	Initial value
OPTION A	NOT USE, TELE, WIDE, FAR, NEAR, AF IR THROUGH, 1/16ND, 1/64ND	NOT USE
OPTION B		
OPTION C		
OPTION D		
BUZZER	OFF, ON	ON

OPTION A - D settings (NOT USE, TELE, WIDE, NEAR, FAR, AF, IR THROUGH, 1/16ND, 1/64ND)

The following functions can be allocated to the OPTION SW [A] to [D] buttons.

NOT USE: The button's function is canceled.

TELE, WIDE, NEAR, FAR:

When a convertible camera or AW-E655 camera, into which has been inserted an optional card with the lens I/F card function, has been directly connected to the ROP, it is possible to control the zooming and focusing of the motorized lens.

With the TELE setting, the lens is zoomed toward the "TELE" end for as long as the option button is held down.

With the WIDE setting, the lens is zoomed toward the "WIDE" end for as long as the option button is held down.

With the NEAR setting, the lens is focused toward the "NEAR" end for as long as the option button is held down.

With the FAR setting, the lens is focused toward the "FAR" end for as long as the option button is held down.

AF: When a lens provided with the auto focus function is used, the ON and OFF settings of the auto focus function are controlled.

Each time the button is pressed, the setting is switched from ON to OFF or vice versa.

When the auto focus function is set to ON, the lamp of the button to which this function has been allocated lights; when it is set to OFF, the lamp is off.

IR THROUGH: The motorized filter of the AW-E655 is set to IR THROUGH. When the button is pressed again, it is set to NORMAL.

The lamp of the button lights when the filter is set to IR THROUGH; it is off when another filter is selected.

1/16 ND: The motorized filter of the AW-E655 is set to 1/16ND. When the button is pressed again, it is set to NORMAL.

The lamp of the button lights when the filter is set to 1/16ND; it is off when another filter is selected.

1/64 ND: The motorized filter of the AW-E655 is set to 1/64ND. When the button is pressed again, it is set to NORMAL.

The lamp of the button lights when the filter is set to 1/64ND; it is off when another filter is selected.

BUZZER setting (OFF/ON)

This is used to set for the buzzer inside the remote operation panel to ON or OFF. The buzzer does not sound at the OFF setting.

The buzzer sounds when the CALL button is pressed.

How to mount the ROP in a rack

- <NOTE>
- The AW-CB400 is 100 mm wide. If it is to be installed in a full-size rack (which accommodates units totaling 420 mm in width), provide panels or other parts to supplement the AW-CB400's width so that it will fill the rack width-wise.
 - If the AW-CB400 is joined to the AW-RP400, the resulting width will be equivalent to that of the full width of the rack (which accommodates units totaling 420 mm in width).

- ① Remove the rubber caps on the side panels.
- ② Use the accessory mounting screws (M4 × 8 mm) to attach the rack-mounting adaptors. Remove the rubber caps.

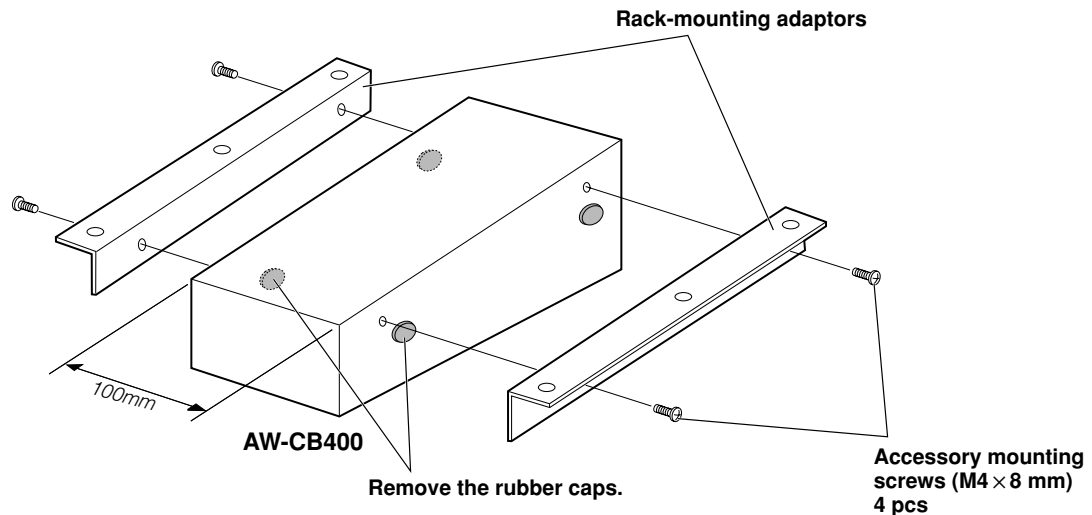

Joining the ROP to the AW-RP400 and mounting the joined-up units in a rack

- ① Remove the rubber caps on the side panels of the AW-CB400.
- ② Attach the accessory join-up screws (stepped screws) to the two places on the side of the ROP which is to be joined to the AW-RP400.
- ③ Adhere the joining stickers onto the side panels of the AW-RP400 concentrically with the join-up screws.
- ④ Align the  holes of the AW-CB400 with the join-up screws, shift in the direction shown by the arrow, and fit the two units together to make a single integrated unit.
- ⑤ Attach the join-up fixture to bottom panels of the AW-RP400 and AW-CB400.
- ⑥ Attach the rack-mounting adaptors using the mounting screws (M4 × 8 mm) provided.

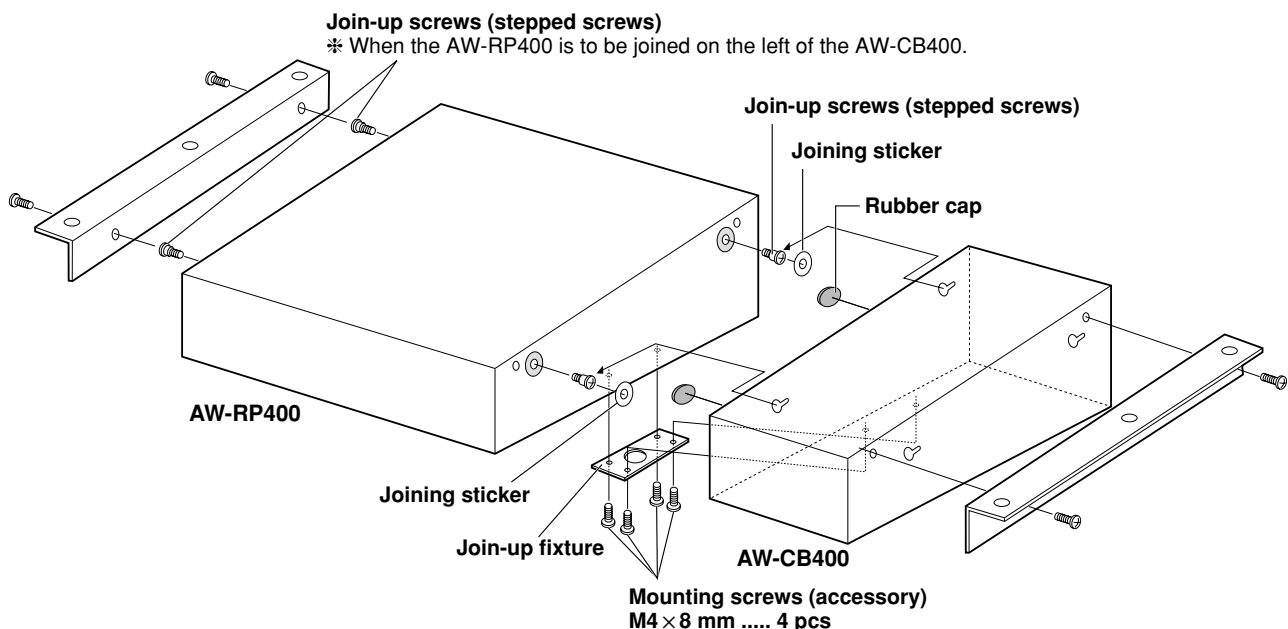

How to change the position of the connector panel

The position of the connector panel can be changed from the rear panel to the bottom panel.

- ① Remove the three screws of the bottom and side panels to remove the blank panel.

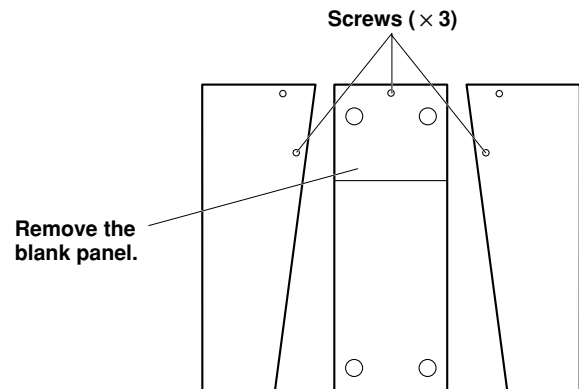

- ② Remove the three screws of the rear and side panels to remove the connector panel.

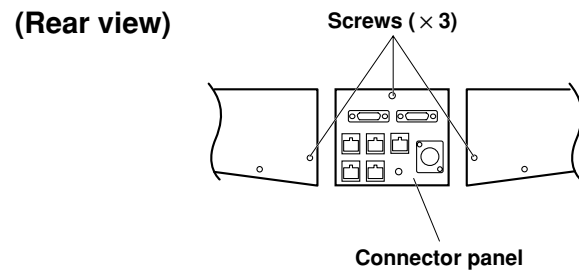

- ③ Secure the blank panel to the rear panel using the screws.

- ④ Remove the two rubber feet of the blank panel.

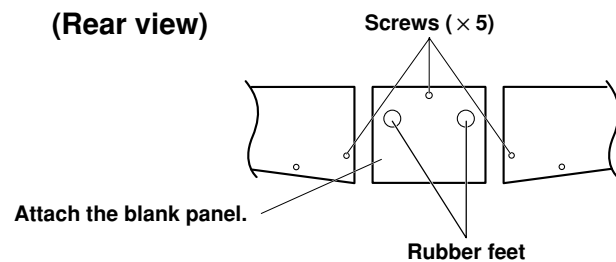

- ⑤ Secure the connector panel to the bottom panel using the screws.

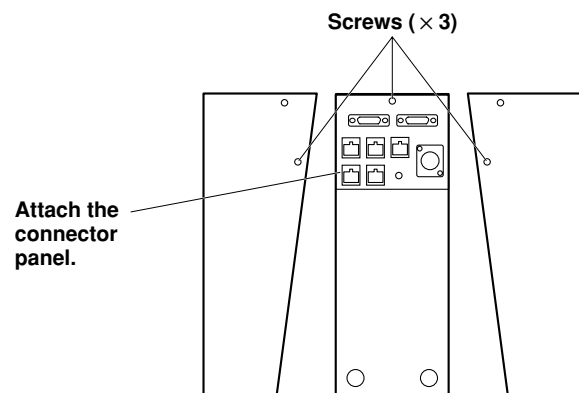

Specifications

Supply voltage: DC 12.0 V

Power consumption: 3.8 W

--

 indicates safety information.

Input connectors

DC 12V IN: XLR, 4 pins
GND: GND terminal

Output connectors

CONTROL OUT
TO CONTROL PANEL: D-SUB 29-pin
CONTROL OUT
TO CAMERA 1 to 5: RJ45, camera control RS-422 level
10Base-T straight cable (UTP category 5), max. 1000 meters

Input/output connectors

INCOM (top panel): XLR, 4 pins
TALLY/INCOM: D-SUB 15-pin
TALLY: Contact input (do not apply a voltage in excess of 5V)
INCOM: 4-wire system

Switch functions:

DATA SET, menu, camera control selection, DTL, scene file selection, gain selection, BAR/CAM switching, white balance selection, AWC, ABC, call, lens iris
AUTO/MANU/LOCK switching, option switches (1 to 4)

Adjustment functions:

LCD contrast, INCOM level, lens iris, menu settings, R-GAIN, B-GAIN, pedestal, R-PED, B-PED

Ambient operating temperature: 14°F to 113°F (−10°C to +45°C)

Storage temperature: −4°F to 140°F (−20°C to +60°C)

Ambient operating humidity: 30% to 90% (no condensation)

Dimensions (W × H × D): 3-15/16" × 3-3/8" × 10-1/2" (100 × 85 × 266 mm)

Weight: 3.1 lbs (1.4 kg)

Finish: Color resembling Munsell 3.5 paint

Weight and Dimensions indicated above are approximate.
Specifications are subject to change without notice.

Panasonic

PANASONIC BROADCAST & TELEVISION SYSTEMS COMPANY
UNIT COMPANY OF MATSUSHITA ELECTRIC CORPORATION OF AMERICA

Executive Office:

One Panasonic Way 4E-7, Secaucus, NJ 07094 (201) 348-7000

EASTERN ZONE:

One Panasonic Way 4E-7, Secaucus, NJ 07094 (201) 348-7621

Southeast Region:

1225 Northbrook Parkway, Ste 1-160, Suwanee, GA 30024 (770) 338-6835

Central Region:

1707 N Randall Road E1-C-1, Elgin, IL 60123 (847) 468-5200

WESTERN ZONE:

3330 Cahuenga Blvd W., Los Angeles, CA 90068 (323) 436-3500

Government Marketing Department:

52 West Gude Drive, Rockville, MD 20850 (301) 738-3840

Broadcast PARTS INFORMATION & ORDERING:

9:00 a.m. – 5:00 p.m. (EST) (800) 334-4881/24 Hr. Fax (800) 334-4880

Emergency after hour parts orders (800) 334-4881

TECHNICAL SUPPORT:

Emergency 24 Hour Service (800) 222-0741

Panasonic Canada Inc.

5770 Ambler Drive, Mississauga, Ontario L4W 2T3 (905) 624-5010

Panasonic de Mexico S.A. de C.V.

Av angel Urraza Num. 1209 Col. de Valle 03100 Mexico, D.F. (52) 1 951 2127

Panasonic Sales Company

Division of Matsushita Electric of Puerto Rico Inc.

San Gabriel Industrial Park, 65th Infantry Ave., Km. 9.5, Carolina, Puerto Rico 00630 (787) 750-4300

Free Manuals Download Website

<http://myh66.com>

<http://usermanuals.us>

<http://www.somanuals.com>

<http://www.4manuals.cc>

<http://www.manual-lib.com>

<http://www.404manual.com>

<http://www.luxmanual.com>

<http://aubethermostatmanual.com>

Golf course search by state

<http://golfingnear.com>

Email search by domain

<http://emailbydomain.com>

Auto manuals search

<http://auto.somanuals.com>

TV manuals search

<http://tv.somanuals.com>