

PARABODY

Serious Steel

445103 425 SECOND STACK OPTION

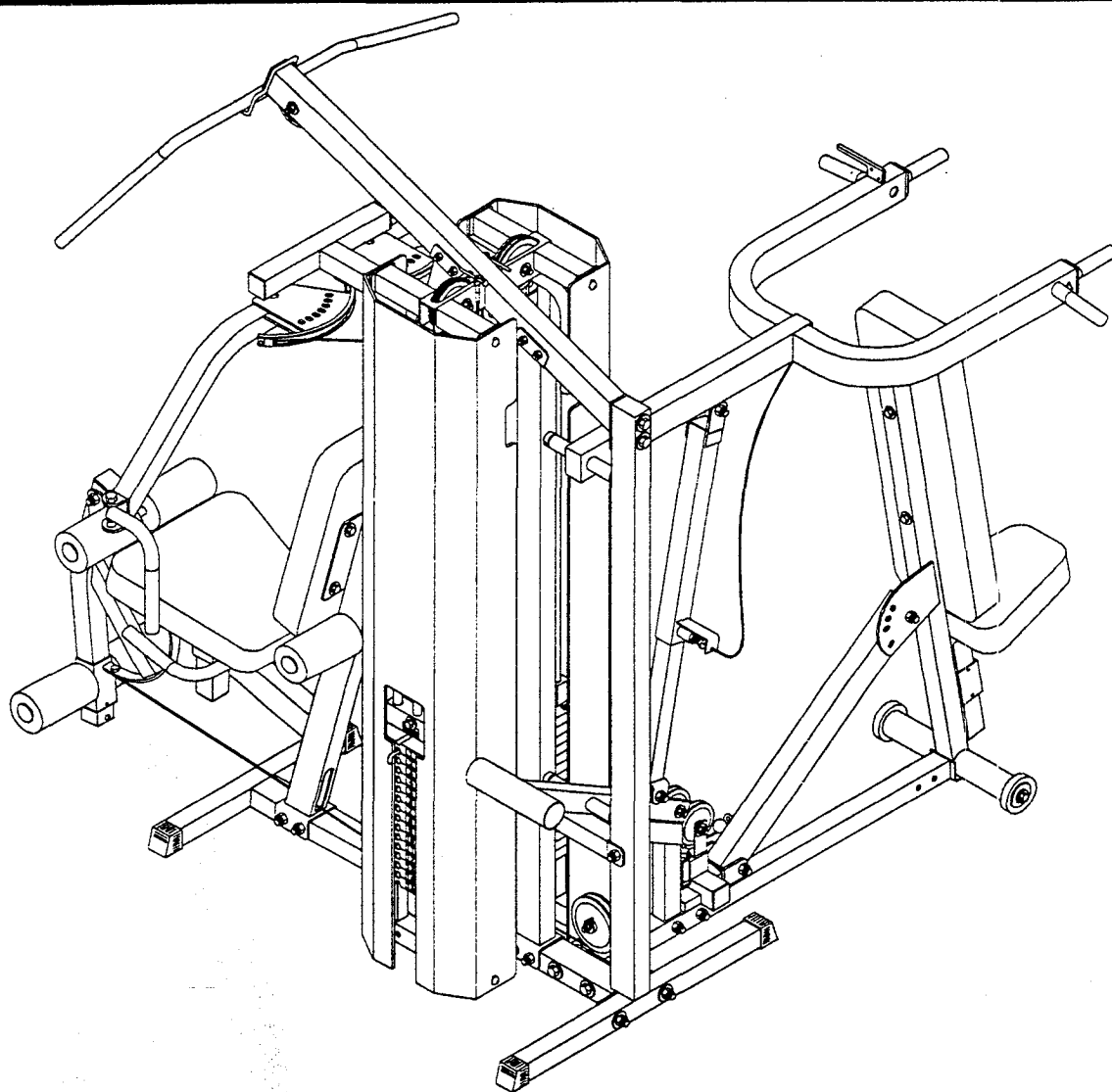

ASSEMBLY INSTRUCTIONS

IMPORTANT NOTES

WELCOME TO THE WORLD OF *Serious Steel!*

Please note:

- * Thank you for purchasing the Parabody 445103 Second Stack Option. Please read these instructions thoroughly and keep them for future reference. This product must be assembled on a flat, level surface to assure its proper function.
- * We recommend cleaning your product (pads and frame) on a regular basis, using warm soapy water. Touch-up paint can be purchased from your Parabody customer service representative at (800) 328-9714.

There is a risk assumed by individuals who use this type of equipment. To minimize risk, please follow these rules:

1. Inspect equipment daily. Tighten all loose connections and replace worn parts immediately. Failure to do so may result in serious injury.
2. Do not allow minors or children to play on or around this equipment.
3. Exercise with care to avoid injury.
4. If unsure of proper use of equipment, call your local Parabody distributor or call the Parabody customer service department at (800) 328-9714.

Tools Required for Assembly

- * Rubber mallet or hammer
- * 3/4" wrench
- * 9/16" wrench
- * Ratchet with 3/4" and 9/16" sockets
- * 7/32" Alien wrench
- * Adjustable wrench
- * Tape measure

Bolt Length Ruler

NOTE: BOLT LENGTH IS MEASURED FROM THE UNDERSIDE OF THE HEAD OF THE BOLT.

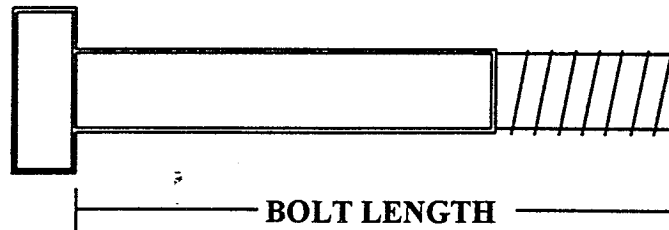

BOLT LENGTH RULER:

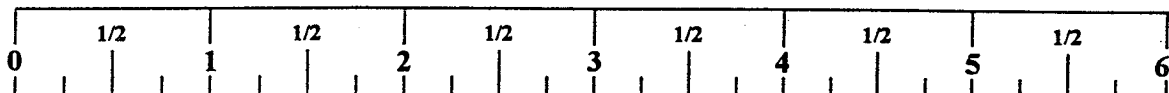

PARTS LIST

| KEY | PART# | DESCRIPTION | QTY | KEY | PART# | DESCRIPTION | QTY |
|-----|---------|------------------------|-----|-----|---------|-----------------------------|-----|
| 1 | 6523401 | GUIDE ROD | 2 | 10 | 3102501 | 3/8" WASHER | 1 |
| 2 | 6266001 | WEIGHT STACK SHAFT | 1 | 11 | 3102802 | 3/8" LOCKNUT | 1 |
| 3 | 6375902 | 1-1/4 SQ. X 4-7/8 TUBE | 2 | 12 | 6480301 | 3/8" FLANGE SPACER | 2 |
| 4 | 6714601 | HEAD PLATE BLACK | 1 | 13 | 3102922 | 3/8 X 2-3/4" BOLT | 1 |
| 5 | 6747501 | PRESS-STACK CABLE | 1 | 14 | 3102901 | 3/8 X 1-1/4" BOLT | 1 |
| 6 | 3116101 | 4-1/2" PULLEY | 1 | 15 | 3102503 | 3/4" WASHER | 2 |
| 7 | 6214401 | WEIGHT STACK PIN | 1 | 16 | 6214501 | WEIGHT PLATE | 15 |
| 8 | 3108002 | WEIGHT STACK CUSHION | 2 | 17 | 6382301 | WEIGHT PLATE BUSHING 10 CT. | 3 |
| 9 | 3117401 | CAP PLUG | 4 | 18 | 6189501 | WEIGHT STACK LABEL | 1 |

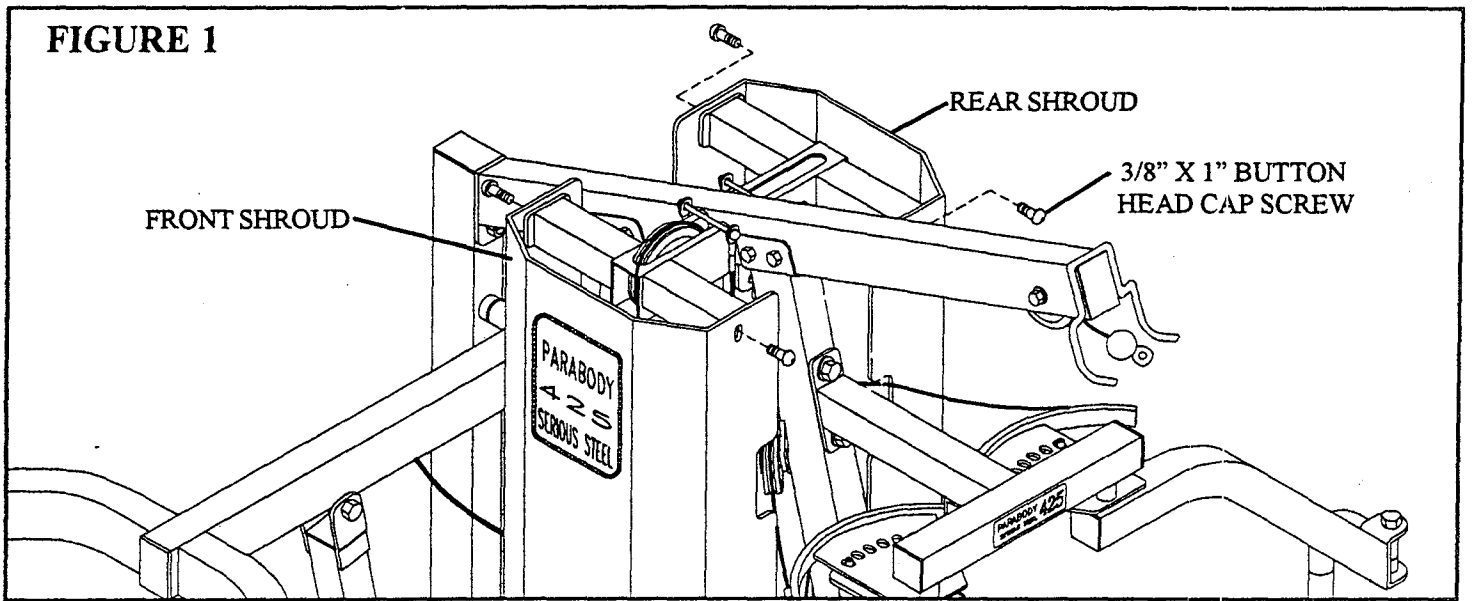

FIGURE 1

STEP 1

- REMOVE the four 3/8" X 1" BUTTON HEAD CAP SCREWS from the top of the front SHROUD & rear SHROUD. See FIGURE 1.

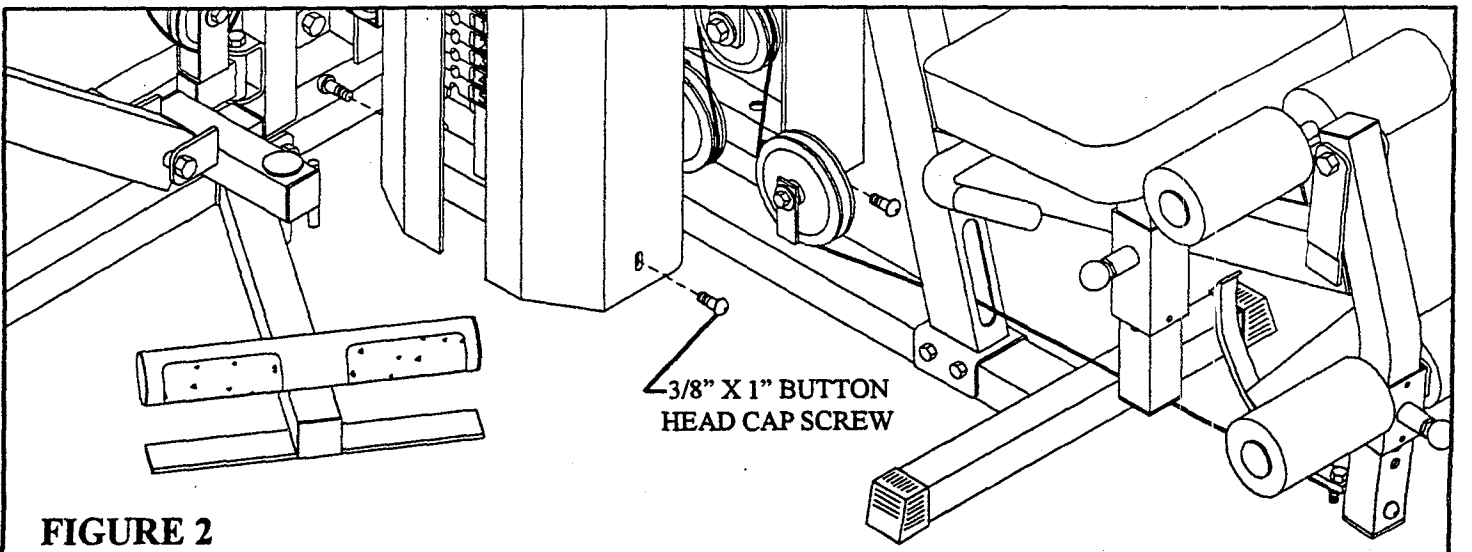
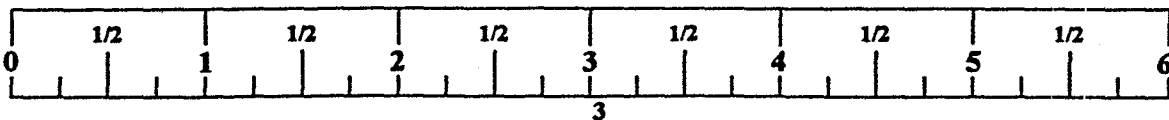

FIGURE 2

STEP 2

- REMOVE the four 3/8" X 1" BUTTON HEAD CAP SCREWS from the bottom of the front SHROUD & rear SHROUD. Remove the SHROUDS from the 425103 HOME GYM. See FIGURE 2.



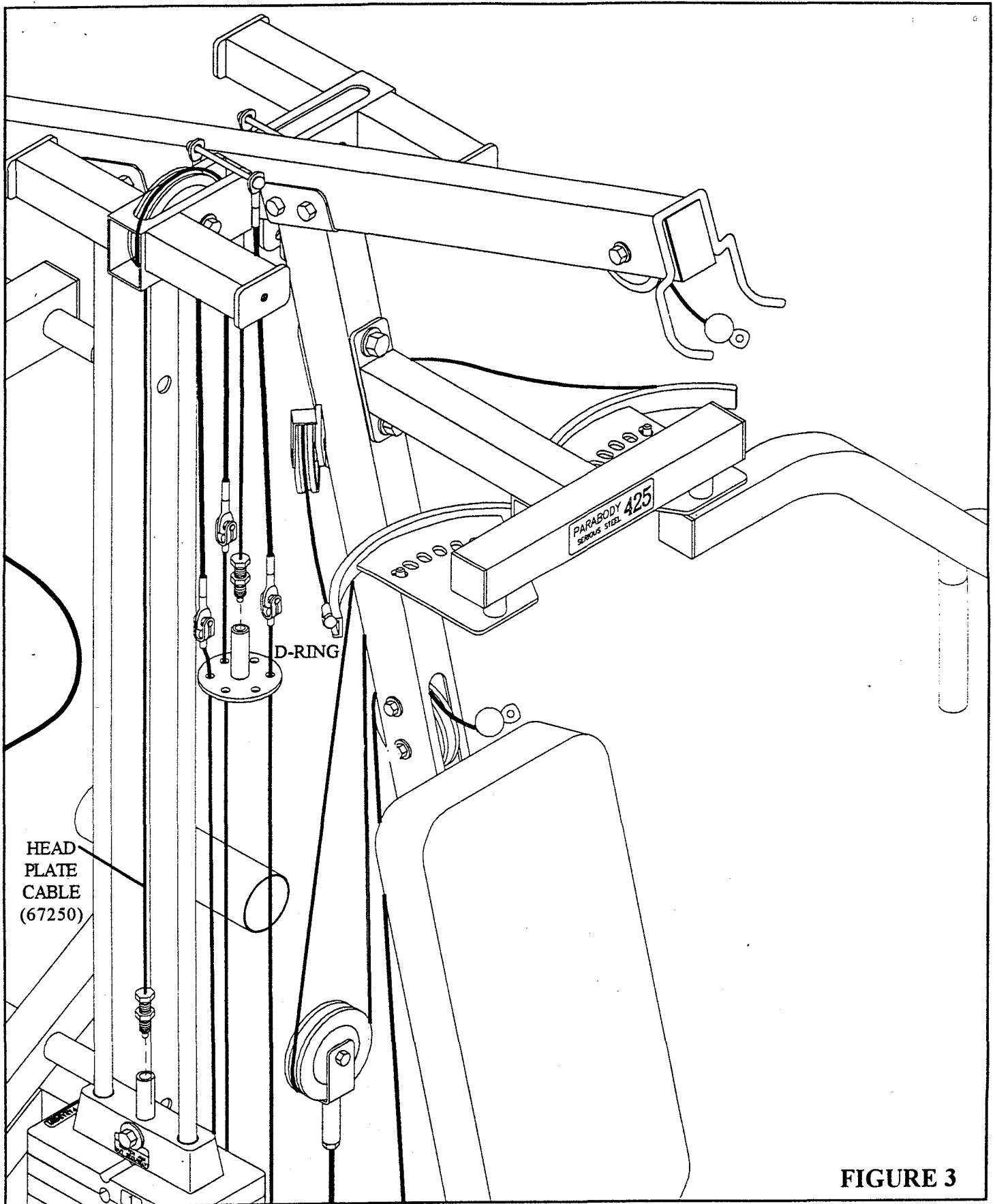

FIGURE 3

STEP 3

- Unscrew the threaded ends of the HEAD PLATE CABLE from the WEIGHT STACK SHAFT & the D-RING and remove HEAD PLATE CABLE. The HEAD PLATE CABLE will be used later. See FIGURE 3. (NOTE: Remove pulleys for ease of removal.)

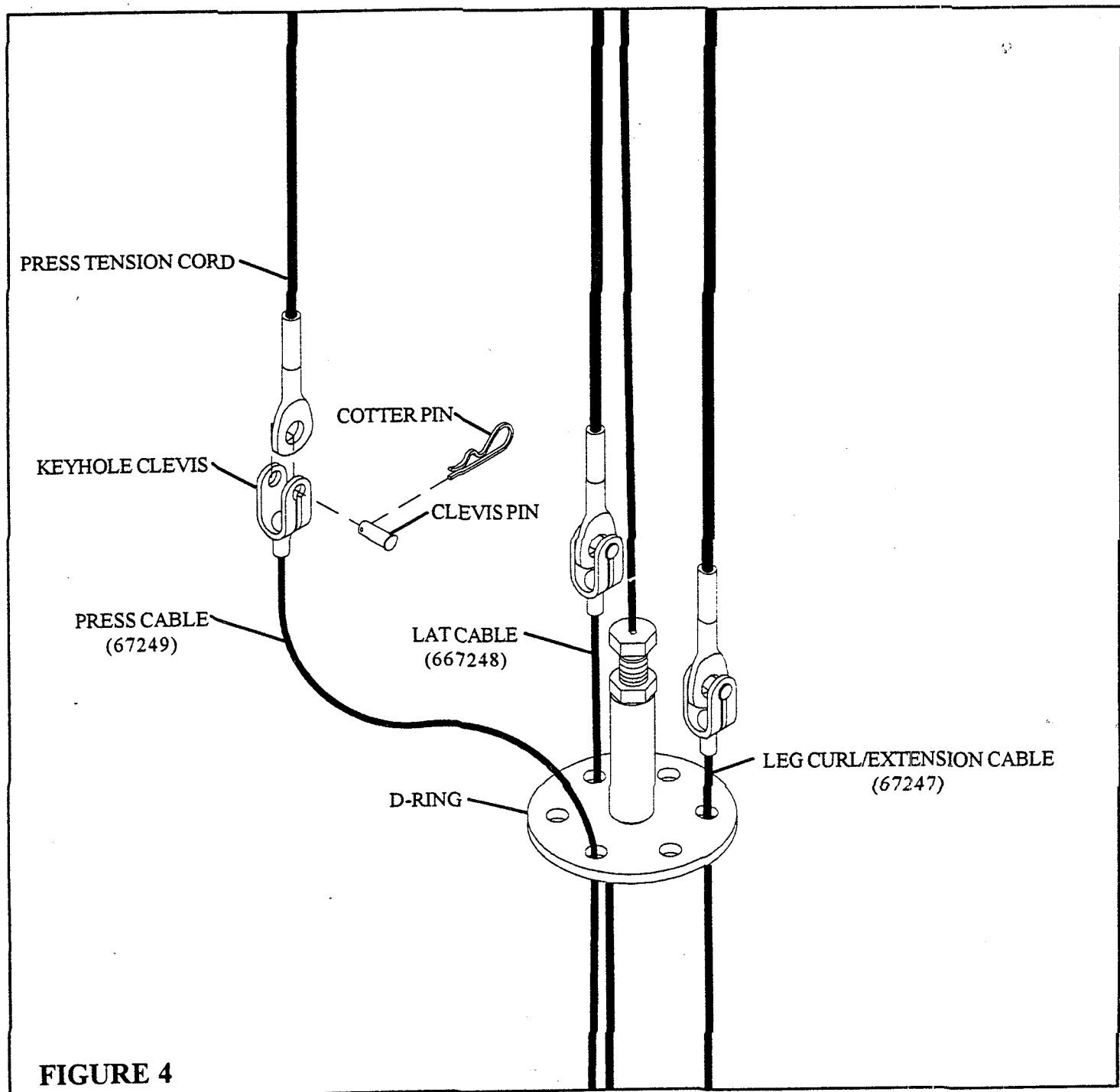

FIGURE 4

STEP 4

- **CAREFULLY** remove the PRESS TENSION CORD and PRESS CABLE by pulling the COTTER PIN and CLEVIS PIN from the KEYHOLE CLEVIS as shown in FIGURE 4.
- **CAREFULLY** remove the 1/4" CAP NUT for the PRESS TENSION CORD on the TOP BOOM.
- Please discard the previously removed PRESS TENSION CORD, PRESS CABLE, COTTER PIN, CLEVIS PIN, and KEYHOLE CLEVIS.

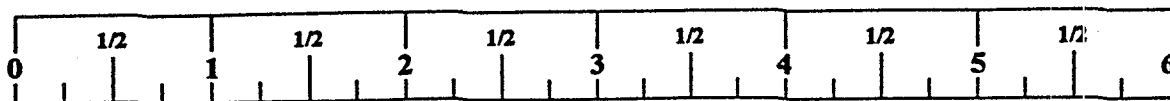
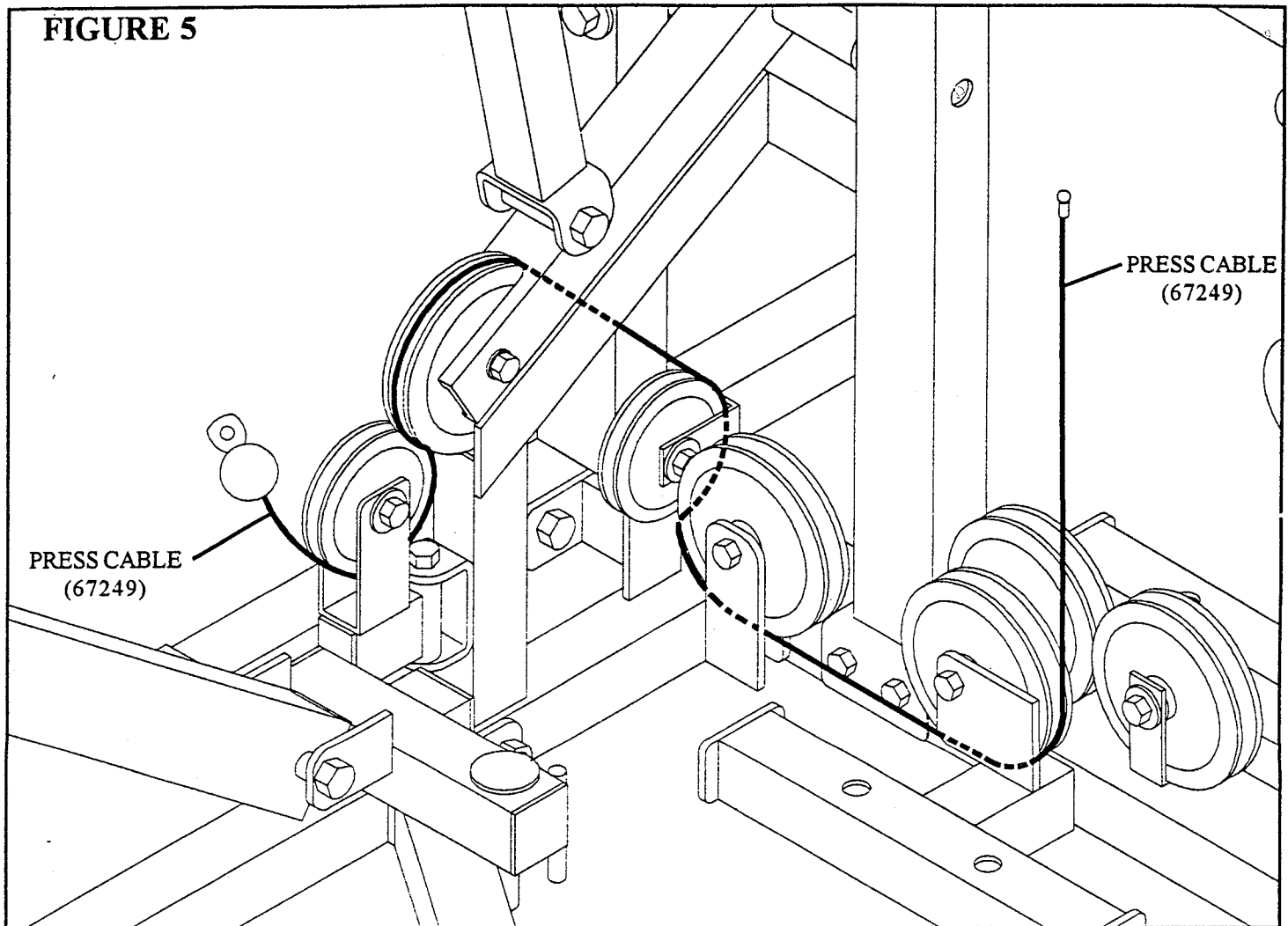

FIGURE 5



STEP 5

- Carefully remove and discard the PRESS CABLE as shown in FIGURE 5.

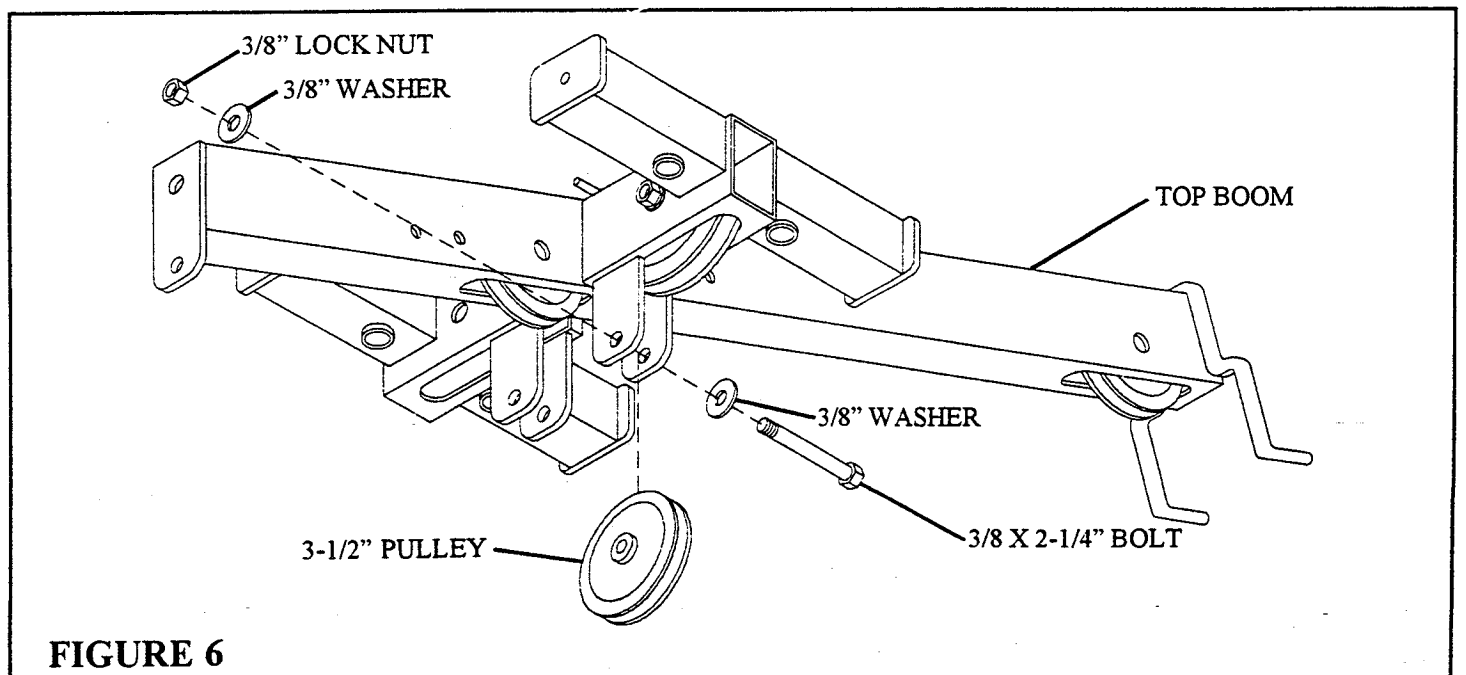

FIGURE 6

- Remove the existing 3-1/2" PULLEY, 3/8 X 2-1/4" BOLT, 3/8" WASHERS, and 3/8" LOCK NUTS from the TOP BOOM. They will be used later. See FIGURE 6..

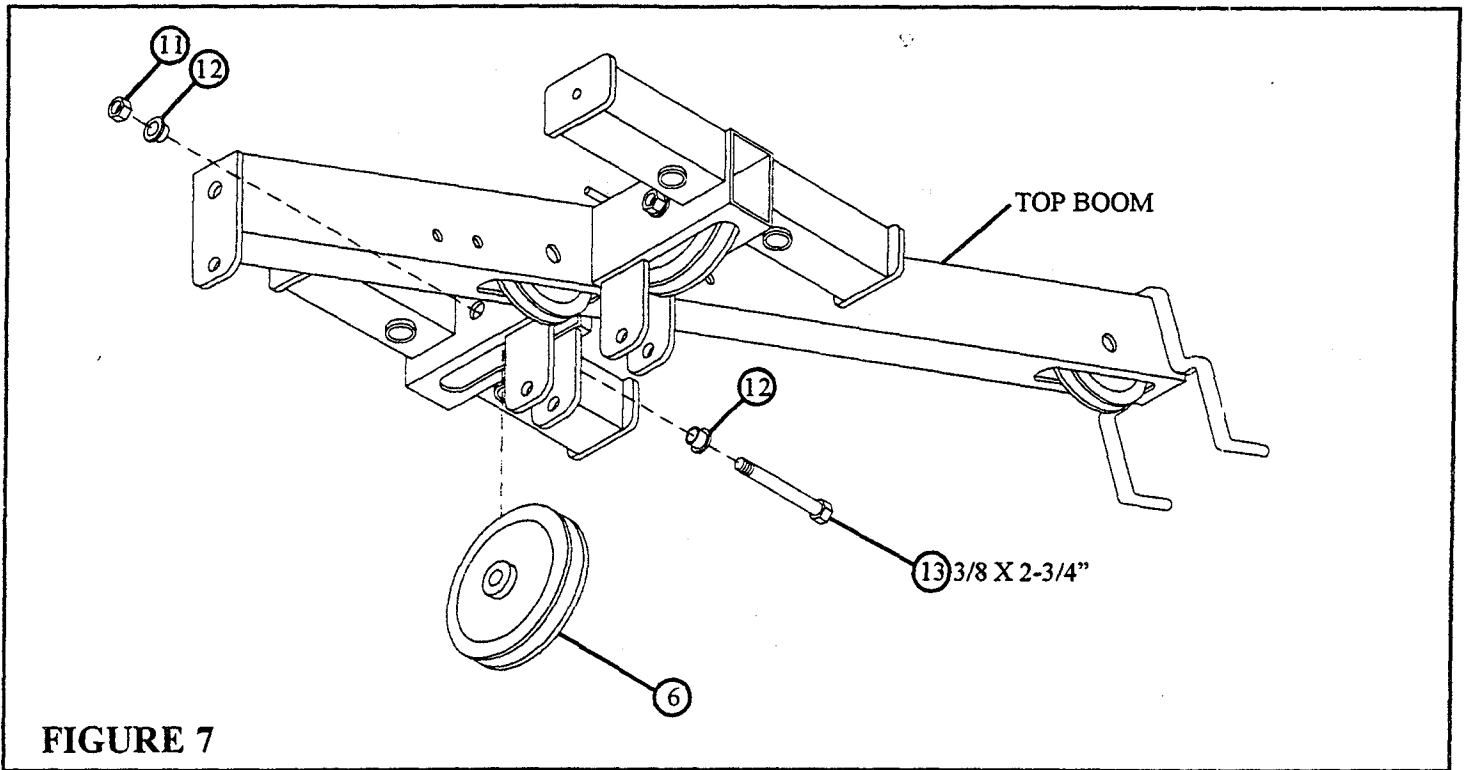

FIGURE 7

STEP 7

- **LOOSELY** assemble one 4-1/2" PULLEY (6) to the TOP BOOM using one 3/8 X 2-3/4" BOLT (13), two 3/8" FLANGE SPACERS (12), and one 3/8" LOCK NUT (11). See FIGURE 7.

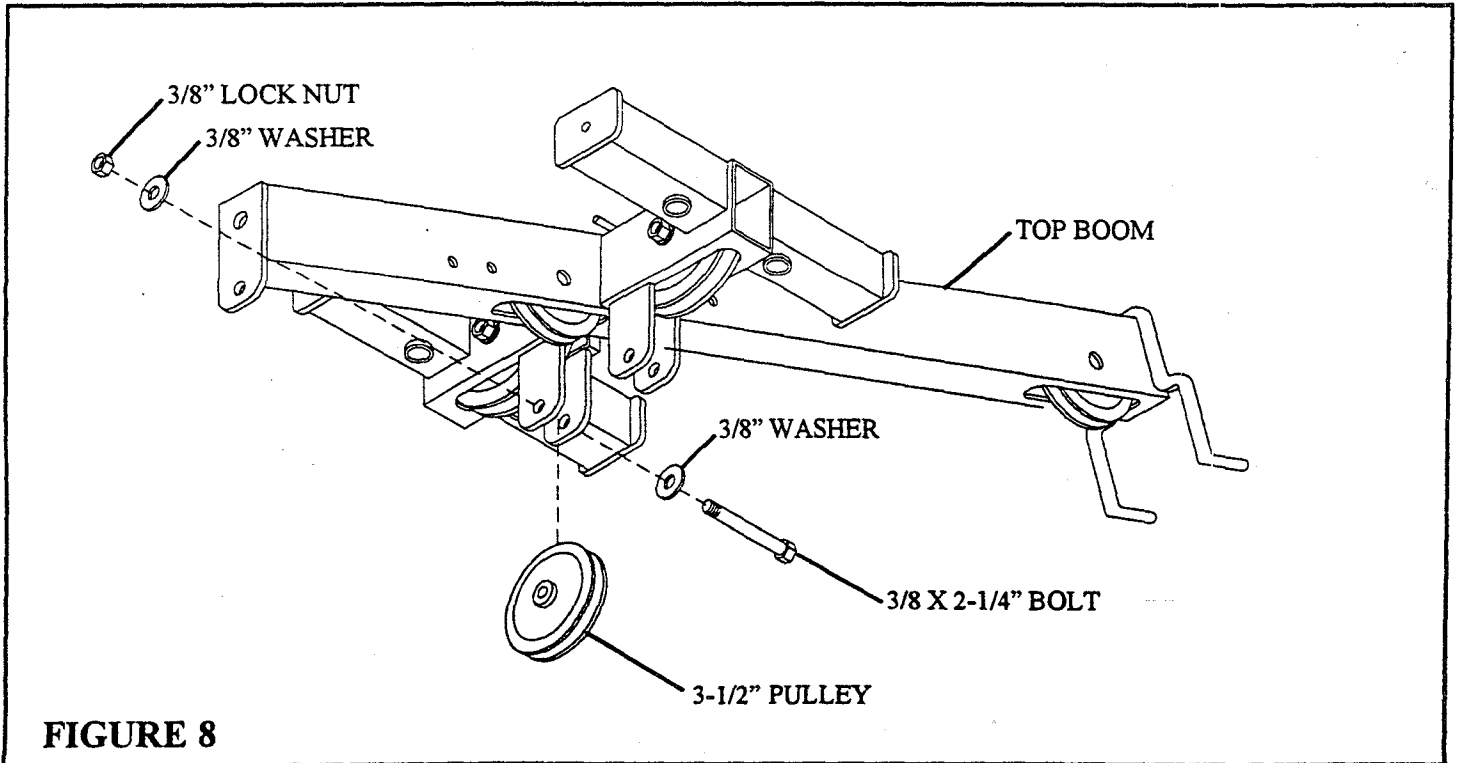

FIGURE 8

STEP 8

- **LOOSELY** assemble the previously removed 3-1/2" PULLEY to the TOP BOOM (17) using the previously removed 3/8 X 2-1/4" BOLT, two 3/8" WASHERS, and one 3/8" LOCK NUT. See FIGURE 8.

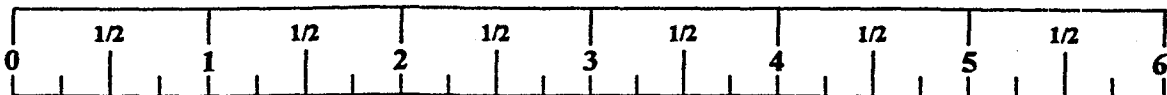
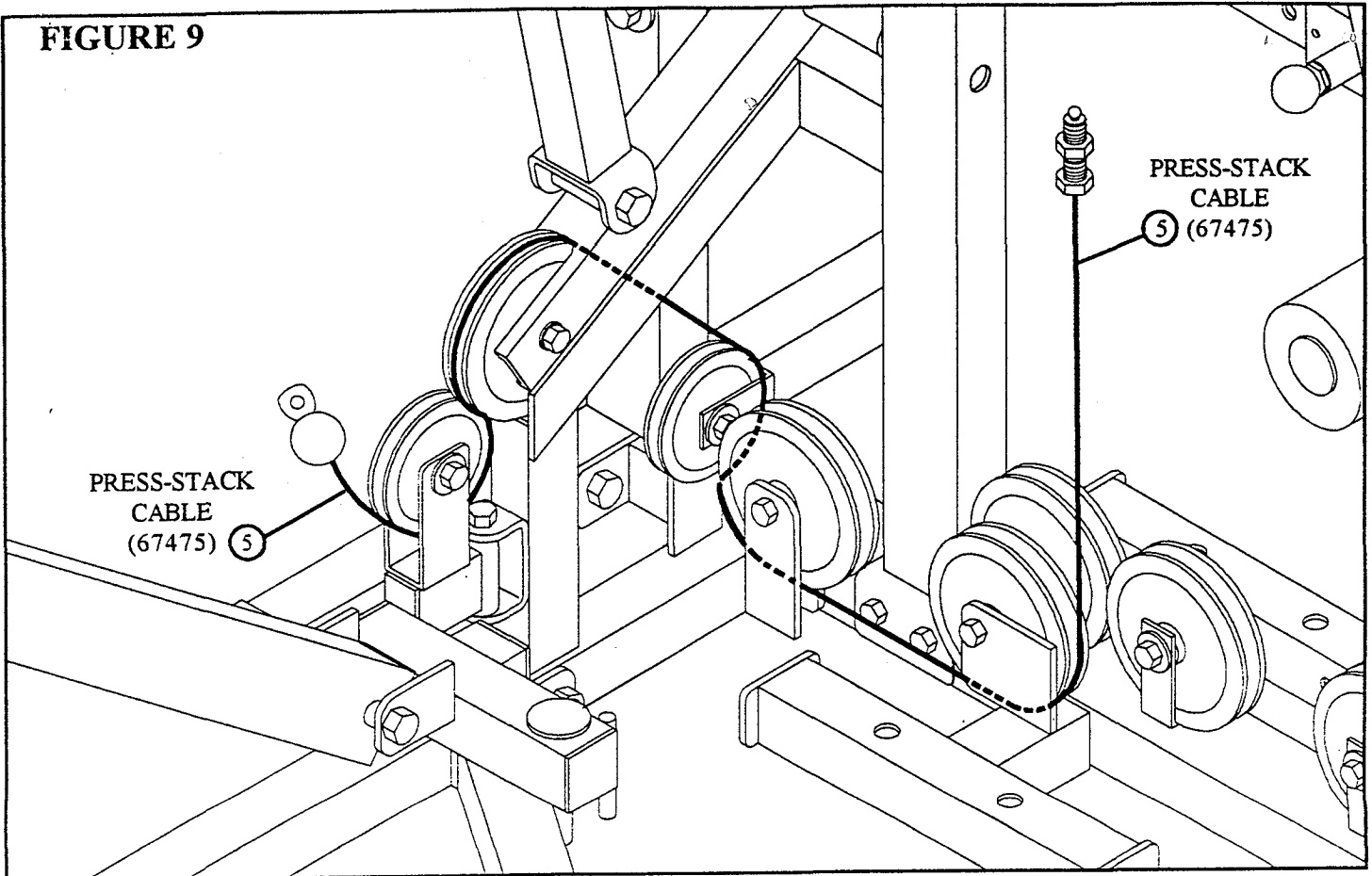

FIGURE 9



STEP 10

- Route the PRESS-STACK CABLE (5) around the pulleys and l-brackets as shown in STEP 9. (Remove pulleys for ease of installation.)

FIGURE 10

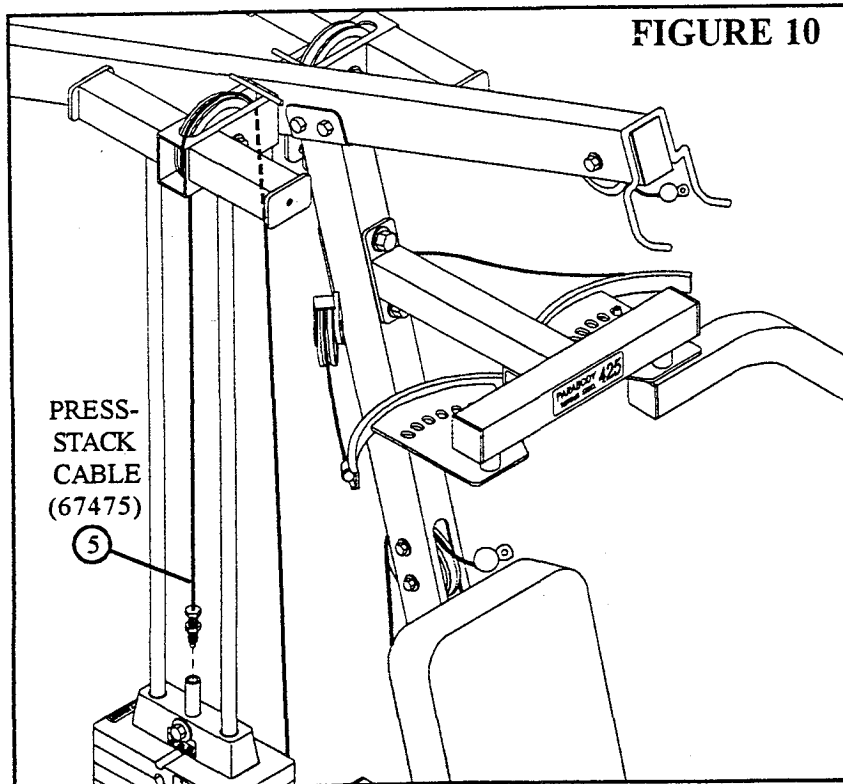

STEP 10

- To assemble the PRESS-STACK CABLE (5) follow the cable routing as shown and use the following steps:
 - Route the thread end of PRESS-STACK CABLE (5) up and over the PULLEY in the TOP BOOM above the WEIGHT STACK. (Remove pulley for ease of installation.)
 - Screw the threaded end of the PRESS-STACK CABLE (5) approximately 1" into the end of the SELECTOR SHAFT of the HEAD PLATE on the WEIGHT STACK as shown in FIGURE 10.
 - **SECURELY** tighten the pulley connection from the previous step.

STEP 12

- Insert two WEIGHT PLATE BUSHINGS (17) into the "PARABODY" side of each of the fifteen WEIGHT PLATES (16) as shown in FIGURE 11.

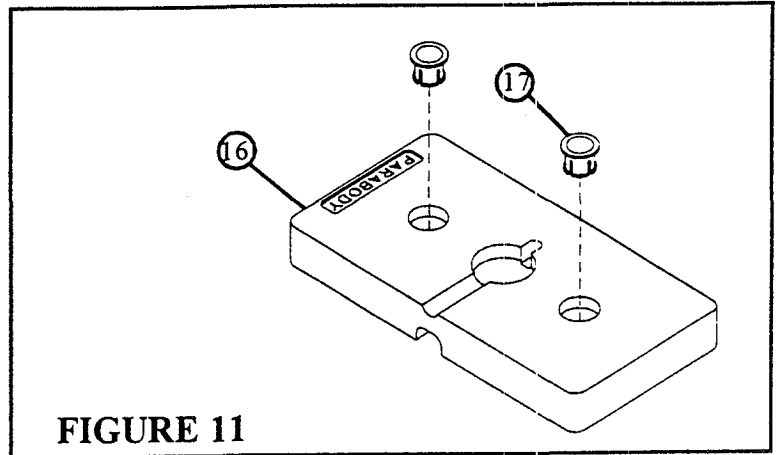

FIGURE 11

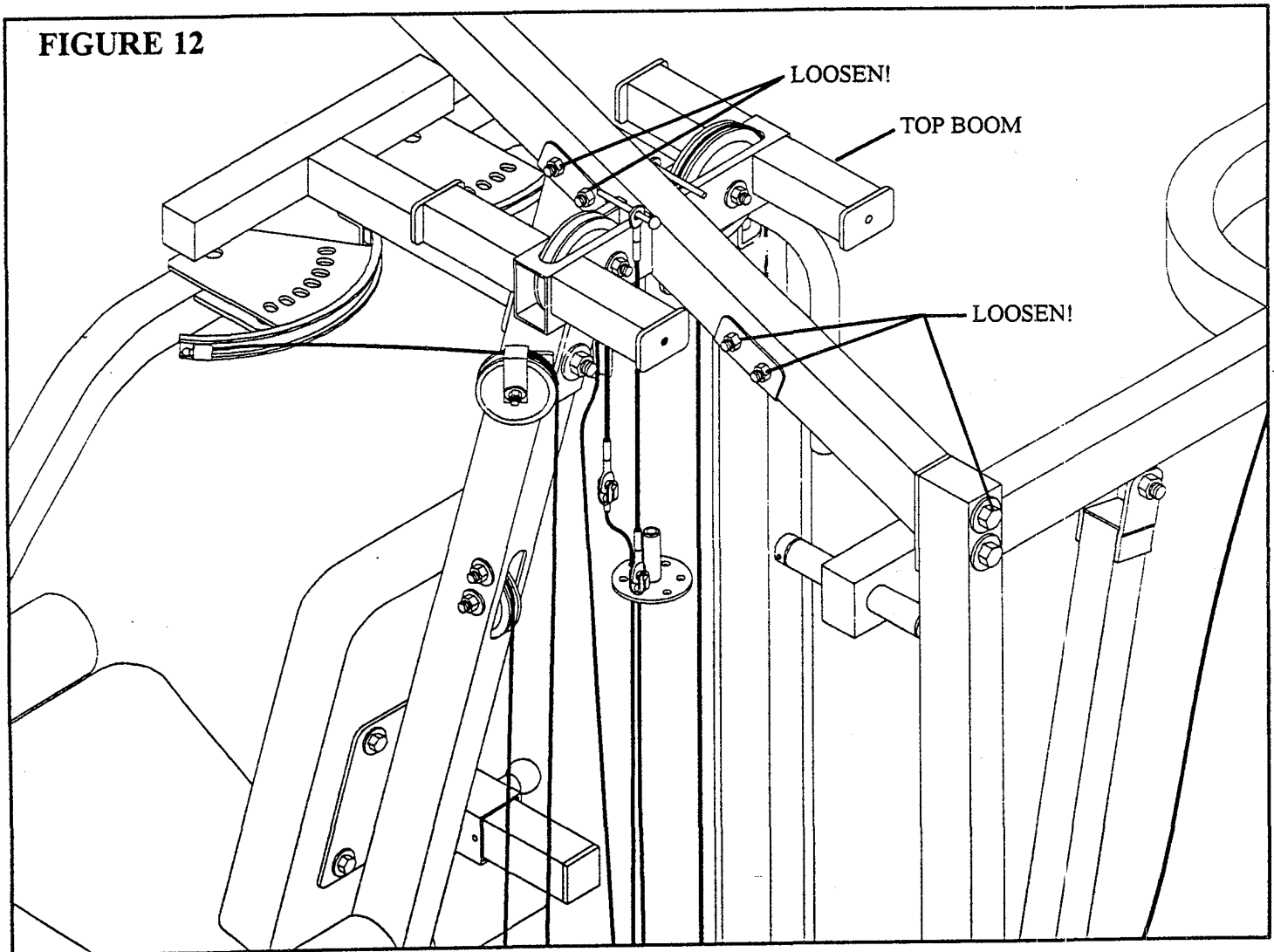
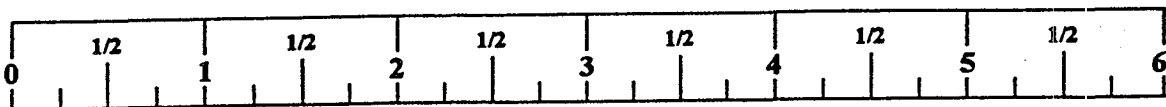

FIGURE 12

STEP 12

- **LOOSEN** the bolts holding the TOP BOOM to the UPRIGHTS. Bolts will have to be removed to install GUIDE RODS (1). See FIGURE 12.



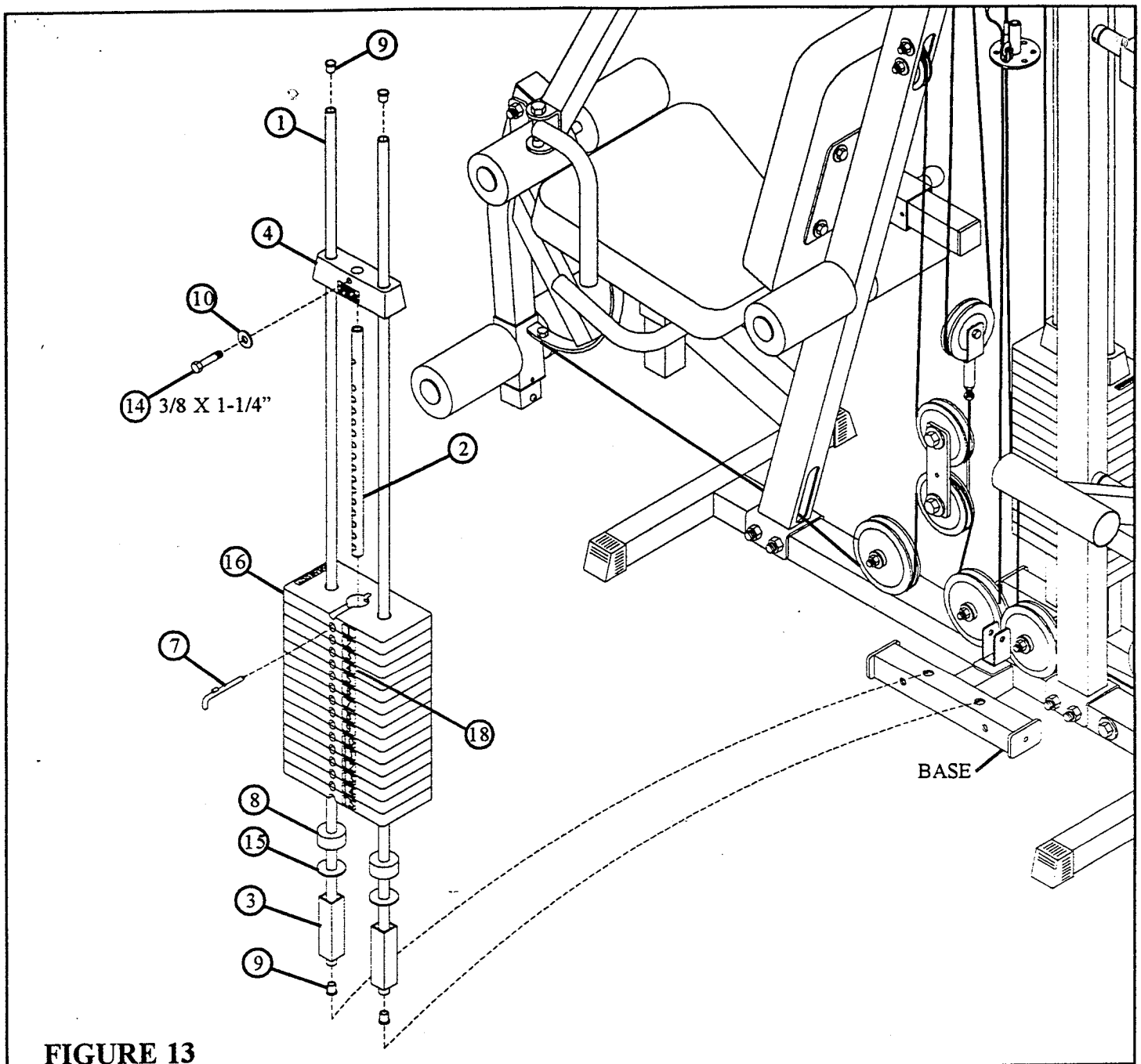

FIGURE 13

STEP 13

- Insert four CAP PLUGS (9) into the top and bottom ends of the GUIDE RODS (1) as shown in FIGURE 13.
- **SECURELY** assemble the WEIGHT STACK SHAFT (2) to the HEAD PLATE (4) using one 3/8 X 1-1/4" BOLT (14) and one 3/8" WASHER (10).
- Insert two GUIDE RODS (1) into the BASE as shown on FIGURE 13. (NOTE: Lubricate GUIDE RODS (1) with silicon or teflon spray available at most hardware stores.)
- Slide two 1-1/4 SQ. X 4-7/8" TUBES (3), two 3/4" WASHERS (15), and two WEIGHT STACK CUSHIONS (8) - **IN THAT ORDER** - down over the GUIDE RODS (1).
- Using **EXTREME CARE** slide all fifteen WEIGHT PLATES (16) down over the GUIDE RODS (1) on to the WEIGHT STACK CUSHIONS (8). Make sure that the keyholes of the WEIGHT PLATES (16) are all facing the right way.
- Slide the head plate assembly down over the GUIDE RODS (1) onto the weight stack.
- Attach the WEIGHT STACK LABELS (18) to the weight stack. Also insert the WEIGHT STACK PIN (7) into the first WEIGHT PLATE (16) of the weight stack.

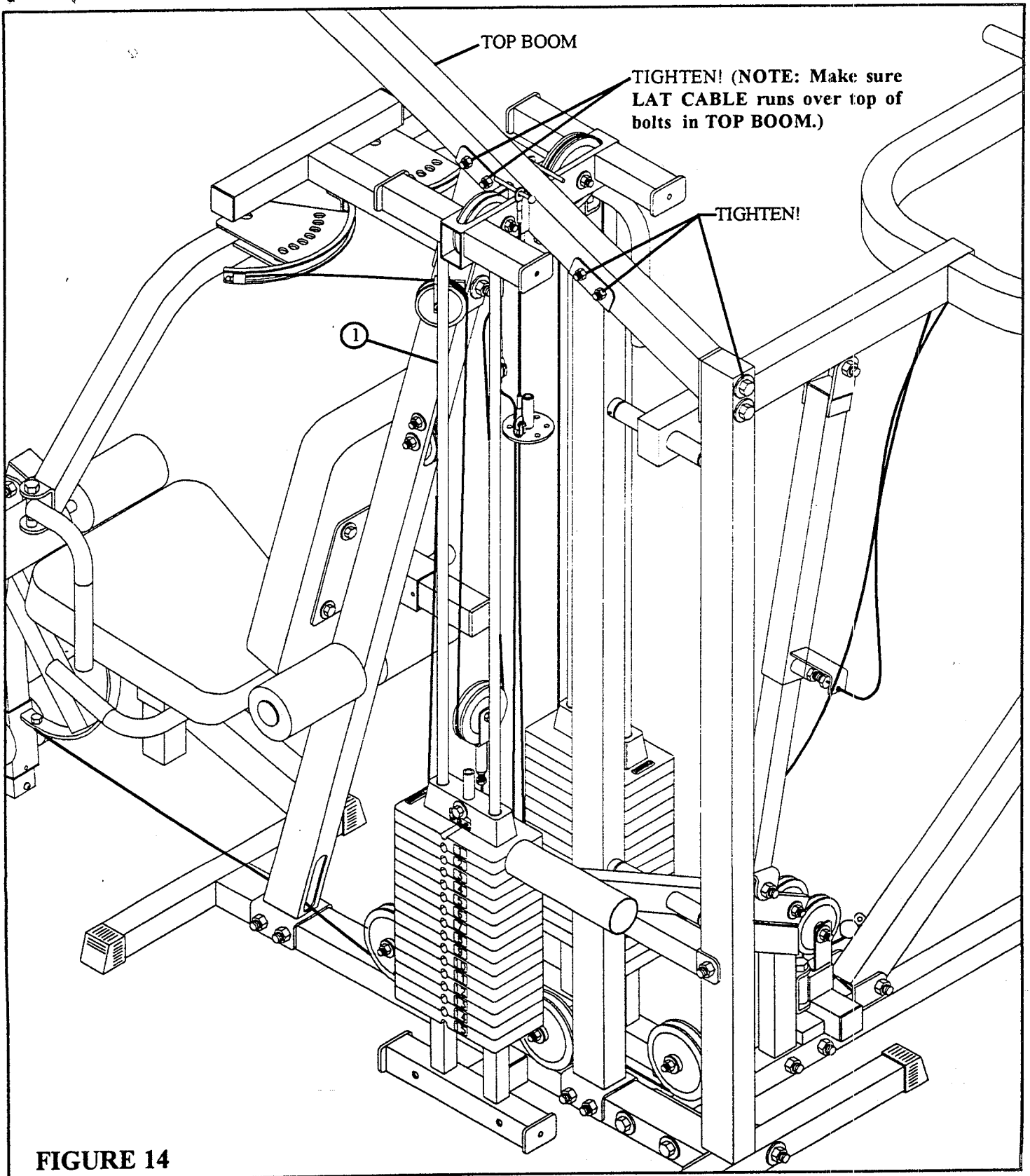
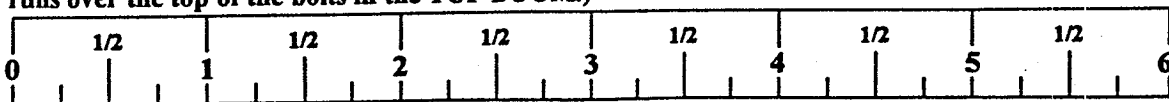

FIGURE 14

STEP 14

- **CAREFULLY** lift or tilt the TOP BOOM and insert all GUIDE RODS into the bushings. See FIGURE 14.
- With the GUIDE RODS (1) securely held in the TOP BOOM. Tighten all TOP BOOM connections. (NOTE: Make sure the LAT CABLE runs over the top of the bolts in the TOP BOOM.)



STEP 15

- Screw one of the threaded ends of the previously removed HEAD PLATE CABLE approximately 1" into the end of the WEIGHT STACK SHAFT. See FIGURE 15.

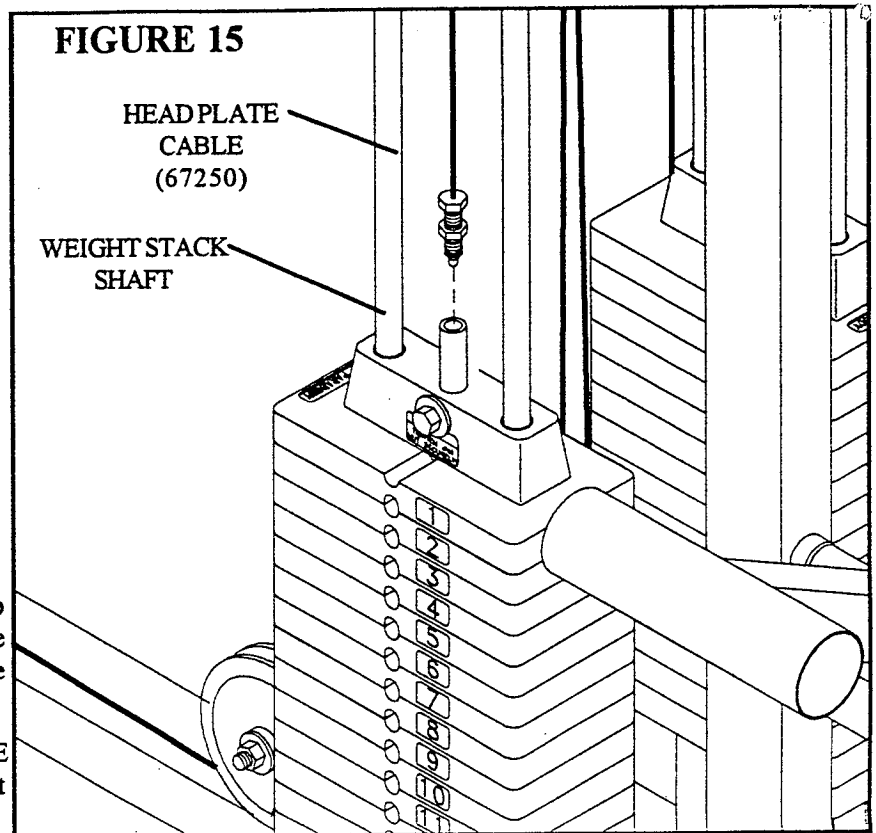

STEP 16

- Route the thread end of HEAD PLATE CABLE up and over the PULLEYS in the TOP BOOM above the WEIGHT STACK. (Remove pulleys for ease of installation.)
- Screw the other threaded end of the HEAD PLATE CABLE approximately 1" into the end of the shaft on the D-RING. See FIGURE 16.
- **SECURELY** tighten the pulleys connection from the previous step.
- Adjust out any slack in the two cable systems. (Refer to your 425103 instructions for the proper procedures.)

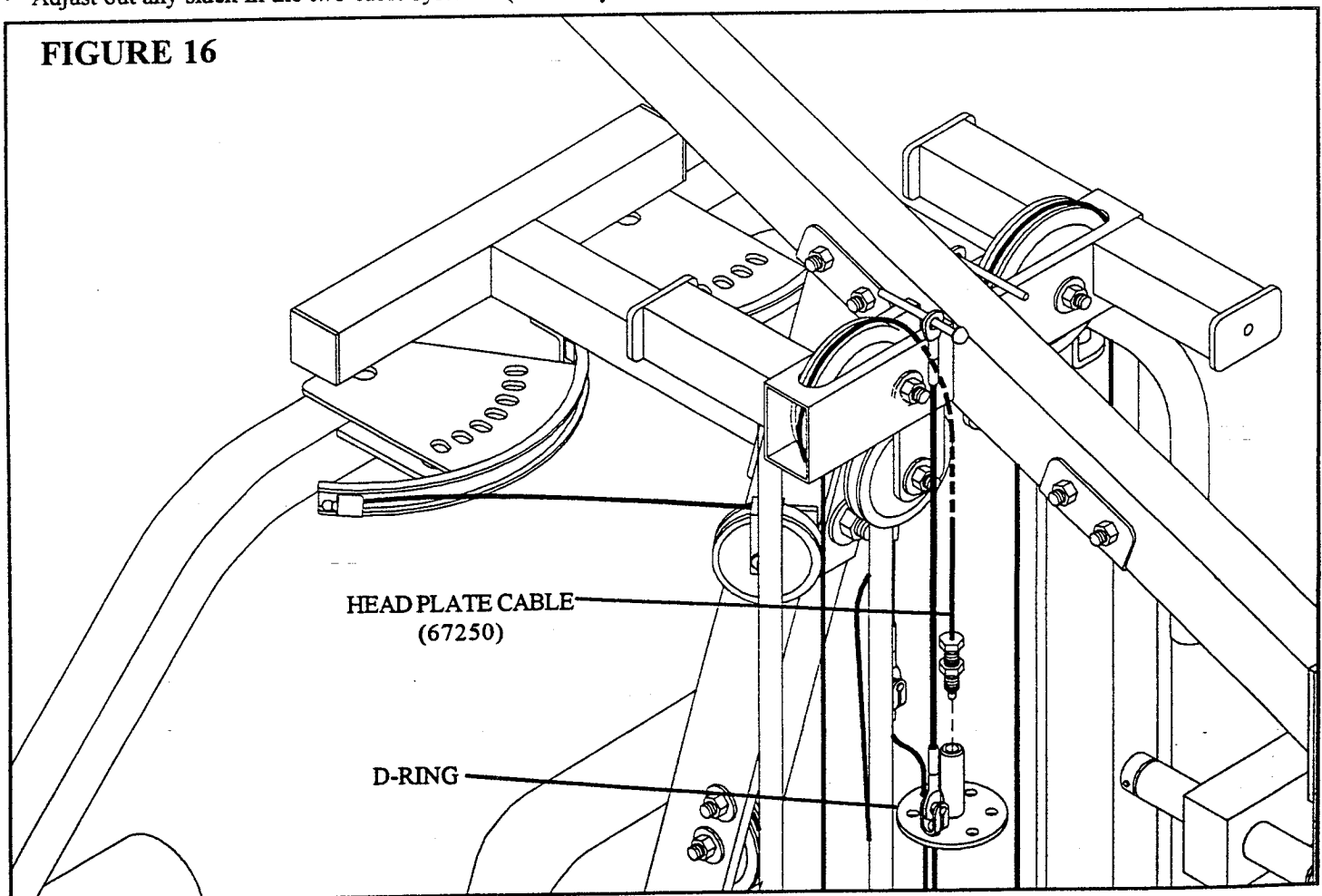



REAR
SHROUD

FIGURE 17

STEP 17

- If the 435103 LEG PRESS ADAPTER KIT is not installed the rear SHROUD opening must be removed. Apply pressure to the bottom of the SHROUD where the "V" groove is and carefully remove the weight stack opening on the plastic SHROUD as shown in FIGURE 17.

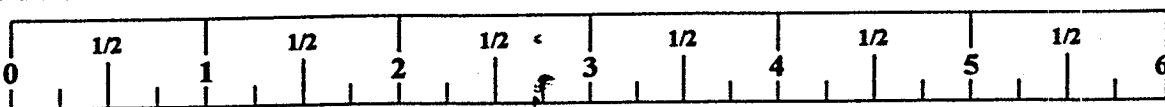
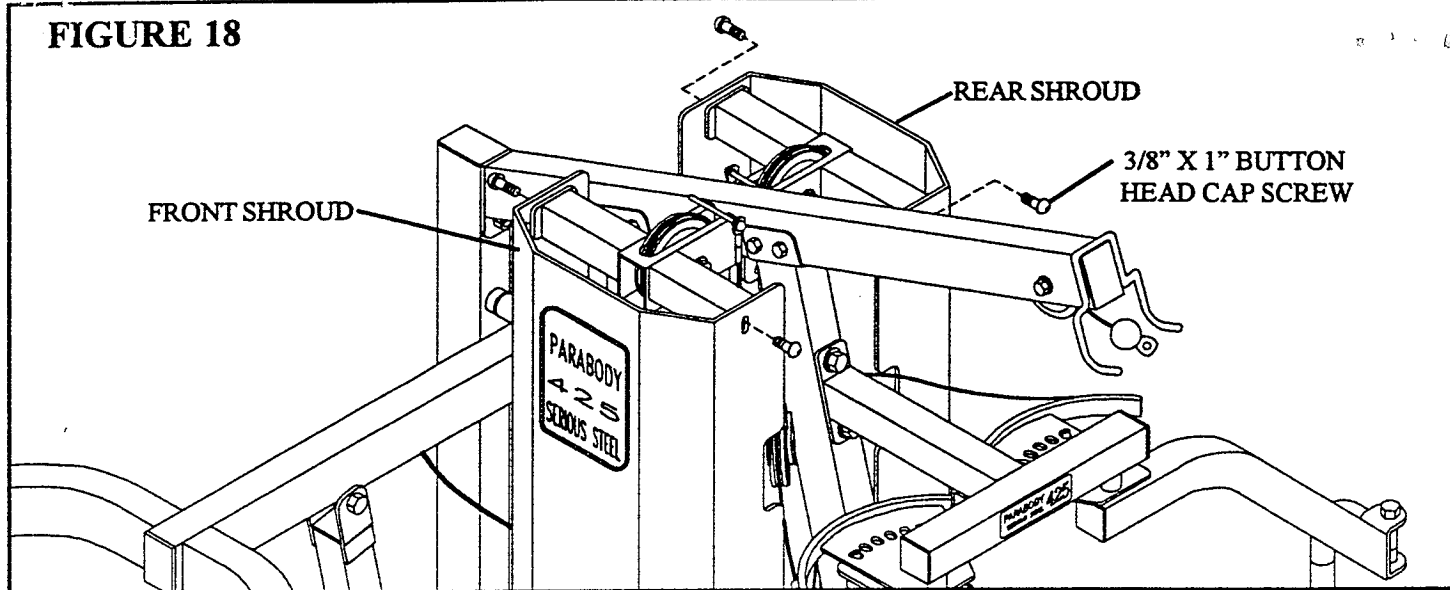

FIGURE 18



STEP 18

- **SECURELY** attach the four previously removed 3/8" X 1" BUTTON HEAD CAP SCREWS from the top of the front SHROUD & rear SHROUD. See FIGURE 18.

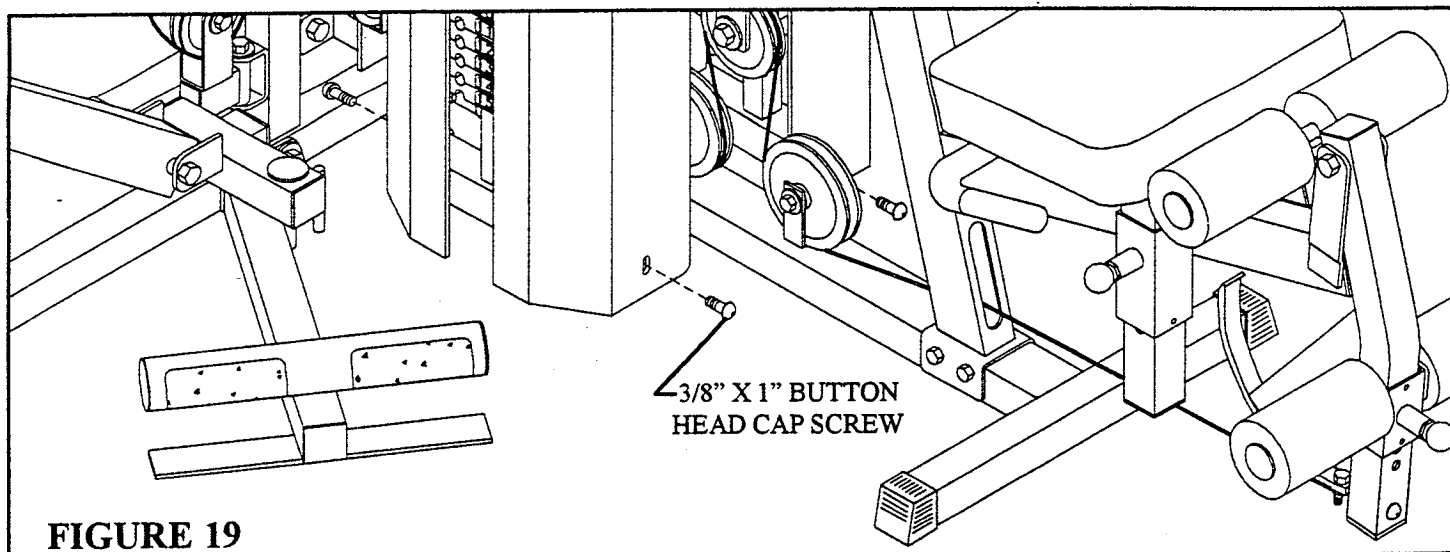

FIGURE 19

STEP 19

- **SECURELY** attach the four previously removed 3/8" X 1" BUTTON HEAD CAP SCREWS from the bottom of the front SHROUD & rear SHROUD. Remove the SHROUDS from the 425103 HOME GYM. See FIGURE 19.
- The PRESS STATION and SWIVEL LOW PULLEY are now operated with the front stack and the LAT, PEC, and LEG STATION are now operated with the rear stack.

Thank you for purchasing the Parabody 445103 Second Stack Option. If unsure of proper use of equipment, call your local Parabody distributor or call the Parabody customer service department at (800) 328-9714.

Free Manuals Download Website

<http://myh66.com>

<http://usermanuals.us>

<http://www.somanuals.com>

<http://www.4manuals.cc>

<http://www.manual-lib.com>

<http://www.404manual.com>

<http://www.luxmanual.com>

<http://aubethermostatmanual.com>

Golf course search by state

<http://golfingnear.com>

Email search by domain

<http://emailbydomain.com>

Auto manuals search

<http://auto.somanuals.com>

TV manuals search

<http://tv.somanuals.com>