



# PARASOUND

---

*P/DD-1500 Digital Surround Processor*



## IMPORTANT SAFETY INSTRUCTIONS



The lightning flash with the arrowhead symbol within an equilateral triangle is intended to alert the user to the presence of “dangerous voltage” within the product’s enclosure that may constitute a risk of electric shock.



The exclamation point within an equilateral triangle is intended to alert the user to the presence of important operating and maintenance instructions in the literature accompanying the product.

### TO REDUCE THE RISK OF ELECTRIC SHOCK, DO NOT REMOVE COVER. NO USER-SERVICEABLE PARTS INSIDE. REFER SERVICING TO QUALIFIED SERVICE PERSONNEL

1. **Read Instructions** — Read all the safety and operating instructions before operating this product.
2. **Retain Instructions** — Retain safety and operating instructions for future reference.
3. **Heed Warnings** — Adhere to all warnings on the product and in the operating instructions.
4. **Follow Instructions** — Follow all operating and use instructions.
5. **Cleaning** — Unplug this product from the wall outlet before cleaning. Use a damp cloth for cleaning.
6. **Attachments** — Do not use attachments not recommended by the product manufacturer; they may cause hazards.
7. **Water and Moisture** — Do not use this product near water.
8. **Accessories** — Do not place this product on an unstable cart or stand. The product may fall causing bodily injury and damage to the product.
9. A product and cart combination should be moved with care. Quick stops, excessive force, and uneven surfaces may cause the product and cart combination to overturn.
10. **Ventilation** — Slots and openings in the cabinet are provided for ventilation and to ensure reliable operation of the product and to protect it from overheating. These openings must not be blocked or covered. *This product should not be placed in a built-in installation such as a bookcase or rack unless proper ventilation is provided.*
11. **Power Sources** — Operate this product only from the type of power source indicated on the marking label. If you are not sure of the type of power supply to your home, consult your dealer or local power company. This product is equipped with a three-wire grounding type plug. This plug will only fit into a grounding type power outlet. If you are unable to insert the plug into the outlet, contact your electrician to replace your obsolete outlet. Do not defeat the safety purpose of the grounding type plug.
12. **Power Cord Protection** — Power supply cords should be routed so that they are not likely to be walked on or pinched by items placed upon or against them.
13. **Lightning** — For added protection for this product during a lightning storm, or when it is left unattended and unused for long periods of time, unplug it from the wall outlet. This will prevent damage to the product due to lightning and power line surges.
14. **Overloading** — Do not overload wall outlets or extension cords. This can result in a risk of fire or electric shock.
15. **Object and Liquid Entry** - Never push objects of any kind into this product through openings; they may touch dangerous voltage points or short out parts that could result in a fire or electric shock.
16. **Servicing** — Do not attempt to service this product yourself. Opening or removing covers may expose you to dangerous voltage or other hazards. Refer all servicing to qualified service personnel.
17. **Damage Requiring Service** — Unplug this product from the wall outlet and refer servicing to qualified service personnel under the following conditions: a) When the power-supply cord or plug is damaged. b) If liquid has been spilled, or objects have fallen into the product. c) If the product has been exposed to rain or water. d) If the product does not operate normally by following the operating instructions. e) If the product has been dropped or damaged in any way. f) When the product exhibits a distinct change in performance.
18. **Replacement Parts** — When replacement parts are required, be sure the service technician has used replacement parts specified by the manufacturer or have the same characteristics as the original part. Unauthorized substitutions may result in fire, electric shock, or other hazards.
19. **Safety Check** — Upon completion of any service or repairs to this product, ask the service technician to perform safety checks to determine that the product is in proper operating condition.
20. **Heat** — The product should be situated away from heat sources such as radiators, heat registers, stoves, or other products (including amplifiers) that produce heat



## Table of Contents

Safety Instructions .....	2
Introduction .....	3
Unpacking and Placement of Your P/DD-1500 .....	3
Making Connections to Your P/DD-1500 .....	6
Input Connections .....	6
Output Connections .....	6
Setting Up Your P/DD-1500 .....	7
Bass Management .....	7
Operating your P/DD-1500 .....	10
P/DD-1500 Processing Modes .....	10
Additional Signal Processing Features .....	11
Using Your P/DD-1500 with Other Processors .....	11
Maintaining Your P/DD-1500 .....	14
Troubleshooting .....	14
Specifications .....	15
Special Features .....	15
Limited Warranty .....	16

## Introduction

Congratulations on your purchase of this precision audio component and thank you for your selection of Parasound. Your P/DD-1500 incorporates high-quality full 20 bit decoders, filters, and D to A converters to process Dolby Digital encoded material to provide you with an unbelievable home theater experience. Although we designed the P/DD-1500 for control by the companion P/SP-1500 A/V Processor/Preamplifier, it can also be used with many other processors that have six discrete inputs.

Please take the time now to read these instructions thoroughly to fully appreciate the advanced capabilities of your P/DD-1500 Digital Decoder. Be sure to refer to the P/SP-1500 Owner's Manual. It contains much of the information regarding connecting, setup and operation of both units.

### Unpacking and Placement of Your P/DD-1500

Carefully unpack your P/DD-1500 and remove all the enclosed accessories including the remote control, DB-25 interconnect cable, and detachable AC cord. Be sure to inspect the unit for any possible shipping damage. If you see any, contact your Parasound Dealer immediately. Save all of the packing material including the outer carton in case you ever need to ship the unit.

Locate the P/DD-1500 near your P/SP-1500 to allow for easy connection with the provided DB-25 interconnect. Keep your P/DD-1500 out of direct sunlight because it could interfere with its remote control sensor. You should also keep the unit away from heat sources such as hot air ducts or radiators. Before you proceed, find the serial number located on the rear panel of your unit and record it for reference:

SERIAL NUMBER: \_\_\_\_\_ DATE OF PURCHASE: \_\_\_\_\_

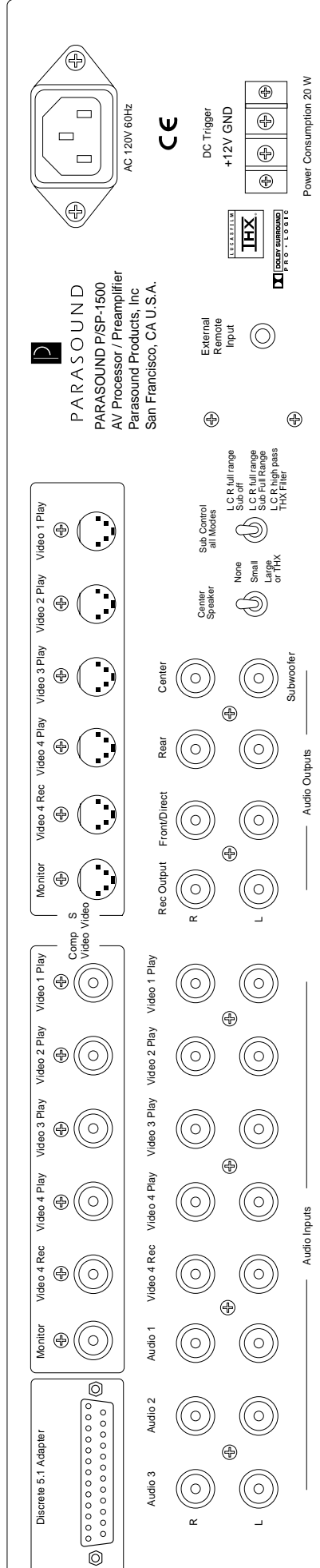
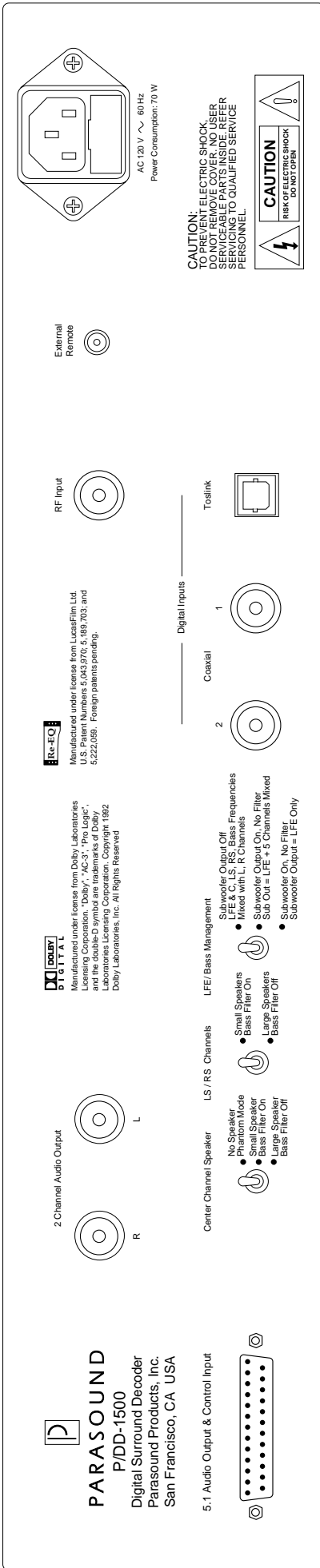

Figure 1: P/SP-1500 and P/DD-1500 Rear Panels

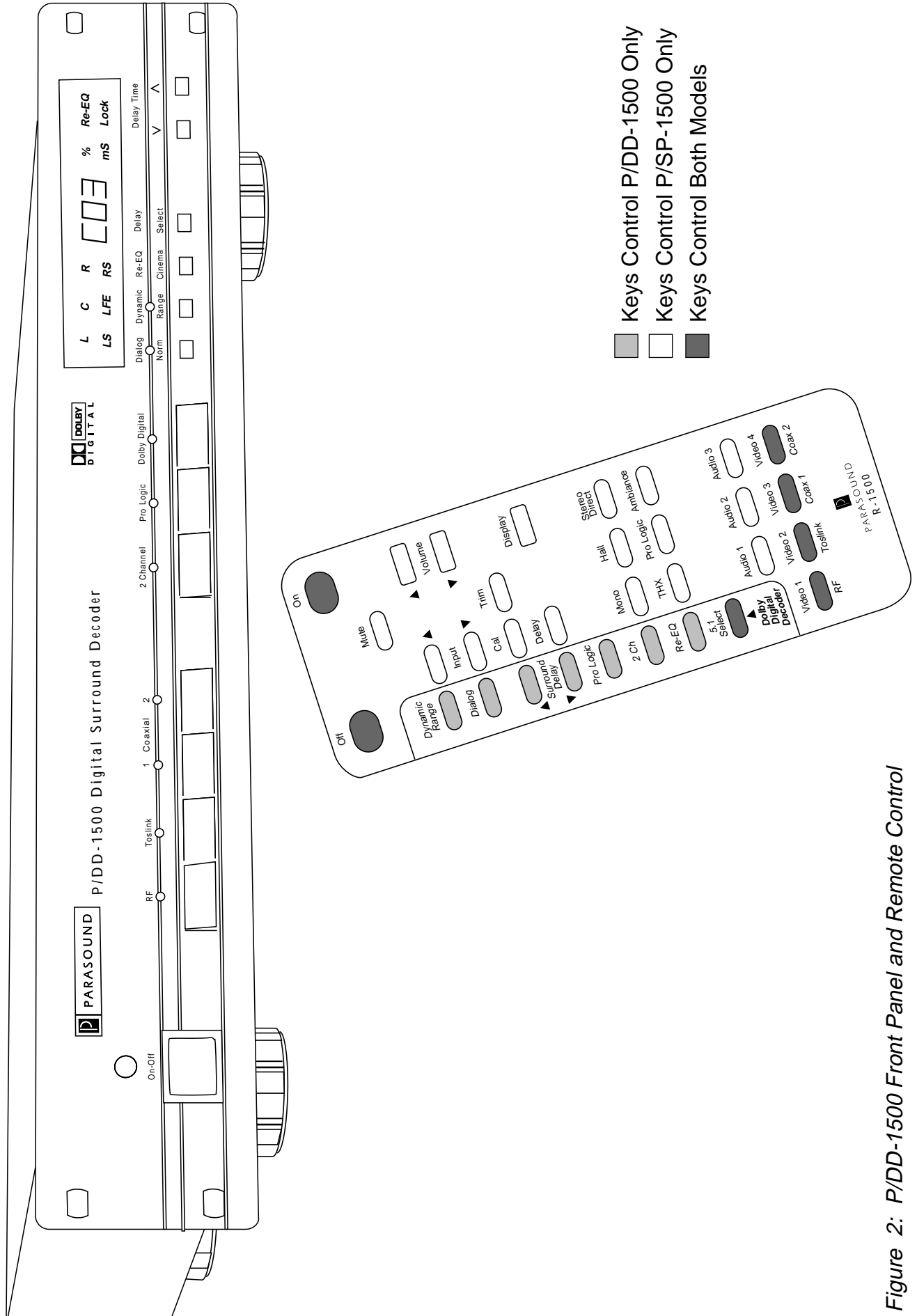

Figure 2: P/DD-1500 Front Panel and Remote Control

## Making Connections to Your P/DD-1500

*Refer to Figure #1*

### Precautions

Before making any connections, be sure to turn off the power to your P/DD-1500, P/SP-1500 and especially your power amplifiers. Also, make sure there is no strain or tension on any connections that could cause them to pull loose.

### AC Line Cord Receptacle

The AC receptacle accepts the AC cord supplied with your P/DD-1500. Plug the female end of the AC cord firmly into the AC receptacle and make sure that it is properly seated.

## Input Connections

Your P/DD-1500 comes equipped with four inputs: one RF, two 75  $\Omega$  digital coaxial inputs and a digital fiber-optic Toslink.

### RF Input

Connect the RF output of your Dolby Digital equipped laser disc player to this input. The P/DD-1500 has a built-in RF demodulator that processes the audio signal stored on Dolby Digital encoded laser discs. The demodulated RF signal is then decoded by the P/DD-1500. If the laser disc was encoded with two channel information, you will only be able to select the Dolby Pro Logic or Two Channel stereo modes for playback. If it was recorded with 5.1 channels of information, the P/DD-1500 will automatically select the Dolby Digital mode and play back all 5.1 channels of audio.

### 75 $\Omega$ Coaxial Inputs

The two coaxial inputs on the P/DD-1500 receive the digital signal from CD, DVD players and other digital components with 75  $\Omega$  coaxial outputs. If the source material has been encoded with Dolby Digital, the digital signal bypasses the RF demodulator and is sent directly to the digital processing circuitry for Dolby Digital decoding. Connect the coaxial output of your DVD player, DSS receiver, or other digital source to either of the coaxial inputs. If the digital source was encoded only with two channel information, you will be able to select only the Dolby Pro Logic or Two Channel stereo modes for playback. If it was recorded with 5.1 channels of information, the P/DD-1500 will automatically select the Dolby Digital mode and play back all 5.1 channels of audio.

### Fiber-Optic Toslink Input

The fiber-optic input on the P/DD-1500 receives digital signals from many DVD players and other digital components with Toslink output connectors. If the source material has been Dolby Digital encoded, the digital signal bypasses the RF demodulator and is sent directly to the digital processing circuitry for Dolby Digital decoding. Connect the Toslink output of your DVD player, DSS receiver, or other digital source to the Toslink input. If the digital source was encoded with two channel information, you will only be able to select the Dolby Pro Logic or two channel stereo modes for playback. If it was recorded with 5.1 channels of information, the P/DD-1500 will automatically select 5.1 channels of Dolby Digital sound.

## Audio Output Connections

### 5.1 Audio Output/Control Connection

The DB-25 connector on the rear panel of your P/DD-1500 sends the processed 5.1 channel analog audio output to the matching DB-25 input connector of the P/SP-1500 AV Processor/Preamplifier. The P/SP-1500 is then used for calibration, bass management, and level adjustment. Use the provided DB-25 interconnect cable to connect the two units together. Once you have made this connection, secure the connectors to the P/SP-1500 and P/DD-1500 with the connector screws.

## Two Channel Audio Output

The P/DD-1500 has two RCA output connectors much like a standard two channel digital to analog converter. Connect these front left and right audio outputs to any input of the P/SP-1500 so you can use its analog processing circuitry for analog Dolby Pro Logic, THX, and music Ambiance. When you press the Two Channel button, you can "downmix" the 5.1 channels of your digital sources so you can record them on your VCR or tape deck.

This unique feature allows you to make listening comparisons between the digital Pro Logic processing circuitry of the P/DD-1500 to the analog Pro Logic processing of the P/SP-1500. With the input you designated for the P/DD-1500's two channel input selected, simply switch between the 5.1 and any other processing mode on the P/SP-1500. Note that when you switch from the 5.1 mode on the P/SP-1500, the analog signal from the P/DD-1500 becomes interrupted.

## Setting up Your P/DD-1500

### Bass Management Configurations with the P/DD-1500 and P/SP-1500

The three bass management switches on the P/DD-1500 and the sub control switch on the P/SP-1500 allow you to set your system to accommodate numerous home theater speaker configurations. Following are descriptions of each of the bass management switches and drawings of recommended switch settings for various speaker system configurations.

#### Low Frequency Effects (LFE)/Bass Management Selector

The three position LFE/Bass Management switch allows you to manage where the low frequencies are routed depending on the requirements of your system:

##### Subwoofer Output Off LFE & C, LS, RS Bass Frequencies Mixed with L, R Channels

In this upper position, low frequencies below 100 Hz from the center and surround speakers are routed to the front left and right speakers and the subwoofer output at the DB-25 connector is muted.

##### Subwoofer Output On No Filter, Subwoofer Output = LFE and Five Channels Mixed

In this mid position, low frequencies below 100 Hz from all 5.1 channels are routed to the subwoofer output at the DB-25 connector.

##### Subwoofer Output On No Filter, Subwoofer Output = LFE Only

In this lower position, only the low frequency effects channel is routed to the subwoofer output at the DB-25 connector.

#### Left Surround and Right Surround Channel Selector

Set this rear panel switch to accommodate the bass capabilities of your surround channel speakers. Following are descriptions of the recommended center channel switch settings based upon the surround speakers you will be using:

##### Small Surround Speakers

Select the lower Small Speakers Bass Filter On position if your surround speakers are not designed to reproduce low bass frequencies above 100 Hz.

##### Large Surround Speakers

Select the upper Large Speakers Bass Filter Off position if your surround speakers are designed to reproduce low bass frequencies below 100 Hz.

## Center Channel Speaker Selector

Set this rear panel switch to accommodate the bass capabilities of your center channel speaker. Following are descriptions of the recommended center channel switch settings based upon the center speaker you will be using:

### No Speaker, Phantom Mode

Select the No Speaker position if you do not have a center channel speaker. In this position, the front right and left speakers share reproduction of the mono center channel signal to create a "phantom" image in the center. In some systems a phantom center channel may provide a wider listening "sweet spot".

### Small Speaker, Bass Filter On

Select the Small Speaker position for typical sized center channel speakers. In this position, the P/DD-1500 protects your center channel speaker from bass overload and distortion by diverting bass frequencies below 100 Hz to the left and right channels. In this position, front channel imaging remains tonally balanced even with the limited bass capability of typical smaller center channel loudspeakers.

### Large Speaker, Bass Filter Off

Select the Large Speaker position for center channel speakers that have extended low bass capability and can play as loud as your front left and right speakers without bass distortion. Use this setting for THX Home Cinema center speakers. In this position, the P/DD-1500 routes the entire audio bandwidth (20 Hz - 20 kHz) to the center channel output.

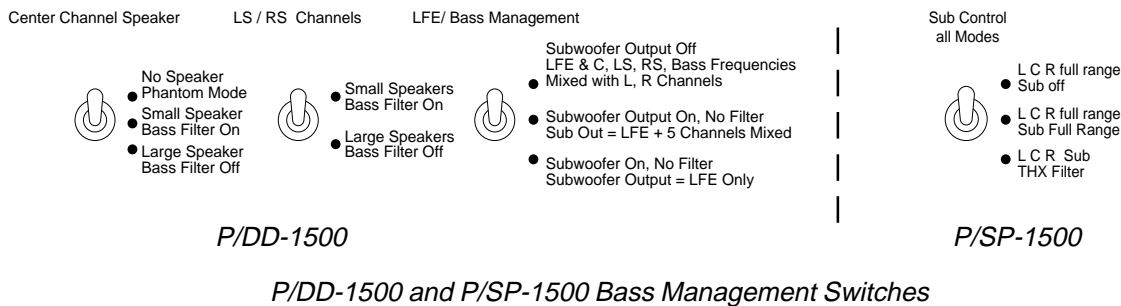

## Internal LFE Level Switch

There is an internal two position DIP switch to select the output level of the LFE channel to accommodate the host processor used with your P/DD-1500. You can select between the factory setting of 3 V or 5.4 V. During setup, if you are not getting enough output level from the subwoofer channel, set this position to the 5.4 V position. Conversely, if you discover that the LFE channel is easily overloaded, set this switch to the 3 V position. To access this switch, you will need to remove the cover panel. Be sure the power is removed from the wall outlet before you reset this switch.

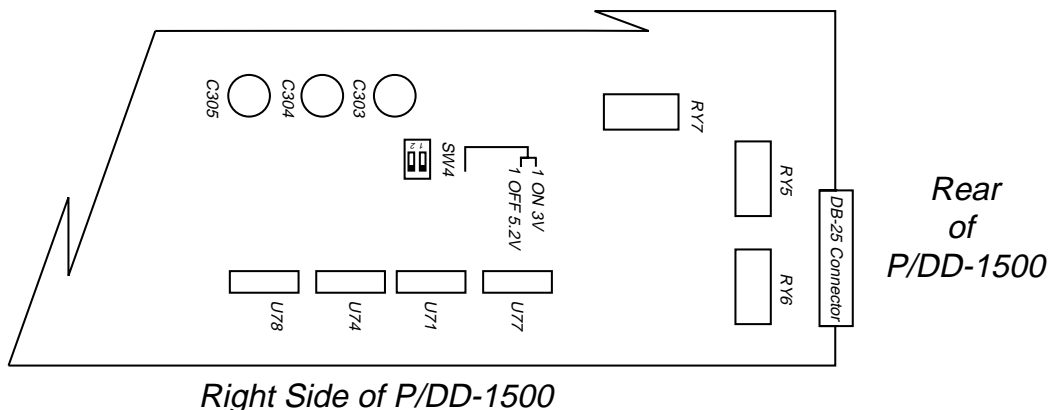



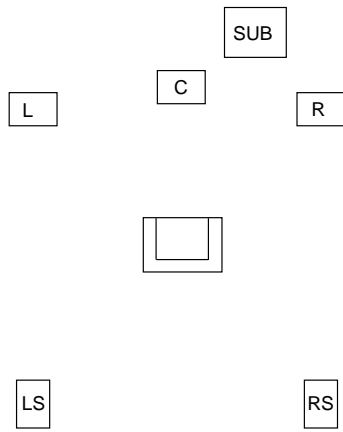

P/DD-1500 Center Channel	P/DD-1500 LS/RS Channels	P/DD-1500 LFE/Bass Management	P/SP-1500 Sub Control
MIDDLE	UP	MIDDLE	DOWN

**Setting # 1:** Small L, C, R, LS, RS speakers. Crossover in subwoofer bypassed. Typical THX Setup

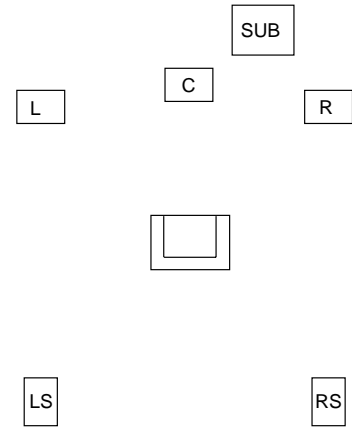

P/DD-1500 Center Channel	P/DD-1500 LS/RS Channels	P/DD-1500 LFE/Bass Management	P/SP-1500 Sub Control
MIDDLE	UP	MIDDLE	MIDDLE

**Setting # 2:** Small L, C, R, LS, RS speakers. Crossover in subwoofer engaged. Typical THX Setup

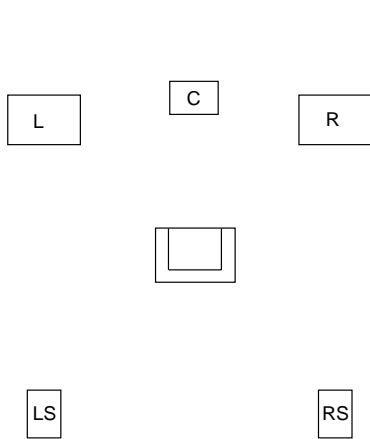

P/DD-1500 Center Channel	P/DD-1500 LS/RS Channels	P/DD-1500 LFE/Bass Management	P/SP-1500 Sub Control
MIDDLE	UP	UP	UP

**Setting # 3:** Large L, R, speakers, small C, LS, RS speakers. No subwoofer.

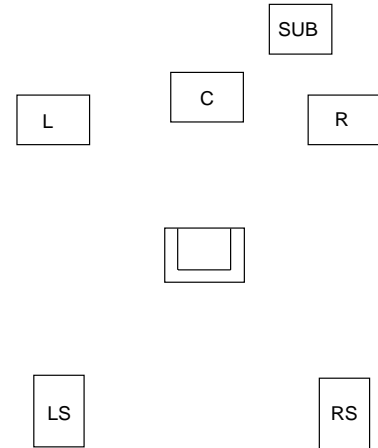

P/DD-1500 Center Channel	P/DD-1500 LS/RS Channels	P/DD-1500 LFE/Bass Management	P/SP-1500 Sub Control
DOWN	DOWN	DOWN	MIDDLE

**Setting # 4:** Large L, C, R, LS, RS speakers. Subwoofer for LFE only.

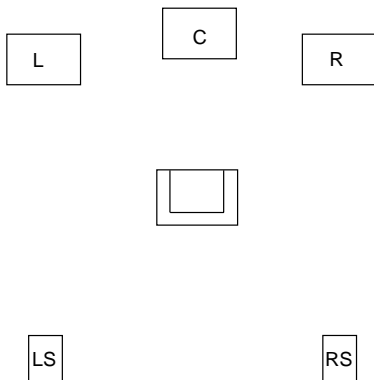

P/DD-1500 Center Channel	P/DD-1500 LS/RS Channels	P/DD-1500 LFE/Bass Management	P/SP-1500 Sub Control
DOWN	UP	UP	UP

**Setting # 5:** Large L, C, R speakers, small LS, RS speakers. No Subwoofer.

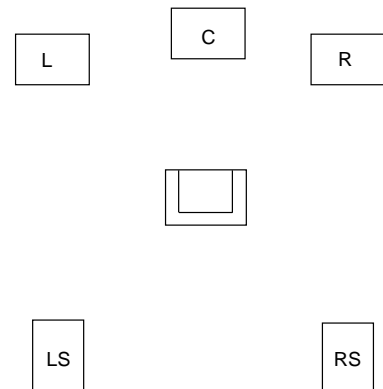

P/DD-1500 Center Channel	P/DD-1500 LS/RS Channels	P/DD-1500 LFE/Bass Management	P/SP-1500 Sub Control
DOWN	DOWN	UP	UP

**Setting # 6:** Large L, C, R, LS, RS speakers. No subwoofer.

## Operating Your P/DD-1500 Digital Surround Decoder

Refer to Figure #2

### Front Panel and Remote and Controls

You can control all of the operations of the P/DD-1500 with either its front panel controls or hand held remote. The remote control gives you complete access to the functions of both your P/SP-1500 and P/DD-1500. These same keys include On, Off, and input selection. Refer to the P/SP-1500 owner's manual for more details about using the remote control to operate your P/SP-1500. Other keys on the remote dedicated to the P/SP-1500 will not affect the P/DD-1500 and pressing any mode other than 5.1 will always disengage the P/DD-1500. Also note that the only on-screen display that applies to the P/DD-1500 is 5.1 mode indicator. Therefore, you will need to refer to the front panel of the P/DD-1500 for its control status.

### Input Selectors

You can select the RF and three digital inputs from the remote control or on the front panel. When you choose an input, a corresponding green LED on the front panel will illuminate to indicate which input you selected. Note that the four AV Inputs on the P/SP-1500 correspond automatically to the inputs on the P/DD-1500: (RF = Video 1, Toslink = Video 2, Coax 1 = Video 3, Coax 2 = Video 4). If you want to select different "non corresponding" inputs for the P/DD-1500 and P/SP-1500, use the input selector buttons on the front panels instead of the remote control.

### P/DD-1500 Processing Modes

You can select three different processing modes from the remote control or on the front panel. When you first turn the unit on and before your digital source is playing, the green LED above the Dolby Digital button and all the **L, C, R, LS, RS, LFE** channel indicators in the front panel display will light to show you that all six channels are ready to receive a signal. Once the P/DD-1500 receives a signal, the **Lock** indicator in the display will illuminate. The P/DD-1500 detects whether the material was recorded in 5.1 or 2 channel and select it automatically:

#### Dolby Digital

If the source you are playing was encoded in 5.1 channel Dolby Digital, the internal decoder automatically selects Dolby Digital processing. The green LED above the Dolby Digital button and all of the amber **L, C, R, LS, RS, LFE** channel indicators will illuminate to indicate 5.1 channel Dolby Digital processing.

#### Pro Logic Surround

If the source material you want to listen to was encoded in Dolby Surround (L<sub>T</sub>, R<sub>T</sub> matrix) you can decode the signal into Dolby Pro Logic by selecting this mode. You can also use this mode to listen to standard two channel material to obtain surround effects that, while not Dolby Pro Logic, may still be quite enjoyable. When you select this mode, the **L, C, R** indicators will light amber, the **LS** and **RS** indicators will light red to indicate standard Pro Logic mono surround channels, and the **LFE** indicator will stay off. If the program material has been encoded in 5.1 channel Dolby Digital, the Pro Logic mode will not operate because the P/DD-1500 will automatically select the Dolby Digital mode.

#### Two Channel

This mode instructs the decoding circuitry to automatically route or "downmix" the center, left and right surround channels to the front left and right channels for two channel stereo playback. In this mode, the P/DD-1500 operates much like a two channel D to A converter such as the Parasound D/AC-1100 HD. Even if the source material has been encoded in Dolby Surround or 2 channel Dolby Digital, the P/DD-1500 will playback the material in stereo. As a result, only the front left, right and subwoofer channels are active in this mode and only the amber **L** and **R** indicators will light. You can select the two channel stereo mode from the remote control or on the front panel.

### Notes on Automatic and Manual Operation of the P/DD-1500's Processing Modes:

- The Dolby Digital mode is automatically engaged when the P/DD-1500 is first turned on or whenever a 5.1 Dolby Digital encoded source is playing.
- You can only change processing modes when a source connected to your P/DD-1500 is playing.
- You can only select the Pro Logic mode with a 2 channel PCM or Dolby Surround encoded source.
- The 2 Channel mode is automatically selected whenever a non-5.1 encoded source is playing.
- You can select the 2 Channel mode to downmix a 5.1 encoded source to stereo operation.

## Additional Signal Processing Features

Your P/DD-1500 also includes additional features that allow you to tailor your home theater system to your specific needs. These additional features include Dialog Normalization, Dynamic Range Compression, and Lucasfilm Cinema Re-Equalization.

### Dialog Normalization

During the recording and mastering process of music and films, sound engineers make different recordings at reference levels that may differ by as much as 12 dB. As a result, when you switch from one source to another, you will probably notice a substantial change in loudness. Dialog Normalization is automatically engaged and allows you to switch between sources with different recorded levels and still perceive the same apparent loudness. This feature makes it possible to accommodate a wide variety of production styles without having to constantly readjust the overall system level. You can disengage Dialog Normalization with either the remote control or on the front panel. However, this automatic function will work only if Dialog Normalization was already programmed into the source material.



75 % Dynamic Range Indication

### Dynamic Range Control

Dynamic range is defined as the difference between the quietest sounds to the loudest peaks of program material. If you want to listen to your system at low levels, simply reducing volume would cause the quietest passages to become inaudible. The Dynamic Range control allows you to hear everything at low volume including the quietest passages. This feature is especially useful for late night listening or when you want to play material at moderate levels without missing any of the program's content. Three Dynamic Range control settings are displayed on the front panel when you press the dynamic range button with either the remote control or on the front panel. When the Dynamic Range LED is off, there is no numerical value in the display and there is no compression. When the display indicates **25%**, 3 dB of the dynamic range is restricted. When the display indicates **50%**, 6 dB of the available compression will be engaged. When the display indicates **75%**, 12 dB of the available compression will be engaged. We did not provide 100% compression. When you first press the Dynamic Range button, The first indication is the level at which it is currently set. Subsequent presses of the control button implement the next settings.

### Lucasfilm Cinema Re-Equalization

The proprietary Lucasfilm Re-Equalization circuitry corrects for the high frequency boost in most film soundtracks for playback in theaters via loudspeakers located behind a screen. As a result, when this material is played back on home speakers located much closer to the listening position, most soundtracks tends to sound unnaturally bright. The Lucasfilm Re-EQ circuit compensates for this boost by precisely attenuating, or "re-equalizing" high frequencies above 15 kHz. You can engage the Re-EQ circuitry with the remote control on the front panel. When engaged, **RE-EQ** appears in the front panel display.

## Center Channel Delay

In a properly configured home theater system, signals from the front left, center, and right speakers should arrive at your listening position at the same time, either by placing your front speakers at the same distance from your listening position, or with electronic delay circuitry. The center channel delay feature provides adjustment for arrival times from the center channel speaker. Use a tape measure or a string to determine the distance from each speaker to your favorite listening position. If the distance from the center speaker to your listening position is the same as the distance from the front left and right speakers, set the center delay time to **0 mS**. If you need to move the center speaker forward to line up on the same plane as the front left and right speakers, add time delay to the center channel to "move" it back electronically and align its arrival time with your front left and right speakers.

You should add 1 millisecond of time delay for every foot the center channel speaker is closer to you than the front left and right speakers. For example, if the center speaker is two feet closer to you than the front left and right speaker, apply a 2 millisecond delay to the center channel to compensate for the shorter distance. This adjustment only needs to be made during initial setup unless you reposition any of your front speakers which is why there is no center delay control on the remote.

To adjust the center delay time, first press the Delay Select button on the front panel until **C** appears in the front panel display. Next, press the delay time up or down to select the desired center delay time. The amount of delay can be adjusted from **0** to **5** milliseconds in 1 millisecond increments. Note that after adjusting the center delay time, the front panel display reverts to **S** for surround delay.



*3 Millisecond Center Channel Delay Indication*

## Surround Channel Delay

Since Dolby Digital processing delivers a discrete signal for each channel, there is no need to delay the surround channels to create a precedence effect to keep the soundstage focus in front of you. Sounds from the surround and front channels should arrive at exactly the same time. As a result, Dolby Digital material only requires a 0 to 15 millisecond surround delay range compared to 15 to 30 milliseconds recommended for Dolby Pro Logic.

To adjust the delay time for the surround channels, press the delay time buttons up or down on the front panel or remote control to select the desired surround delay time. The amount of delay can be adjusted from **0** to **15** milliseconds in 5 millisecond increments. However, the delay time for Dolby Pro Logic material is automatically set by the P/DD-1500 at 15 mS. Note that setting surround delay time on the P/DD-1500 does not effect the delay time set on the P/SP-1500. Refer to the chart on the following page for optimum surround delay times.



*10 Millisecond Surround Channel Delay Indication*

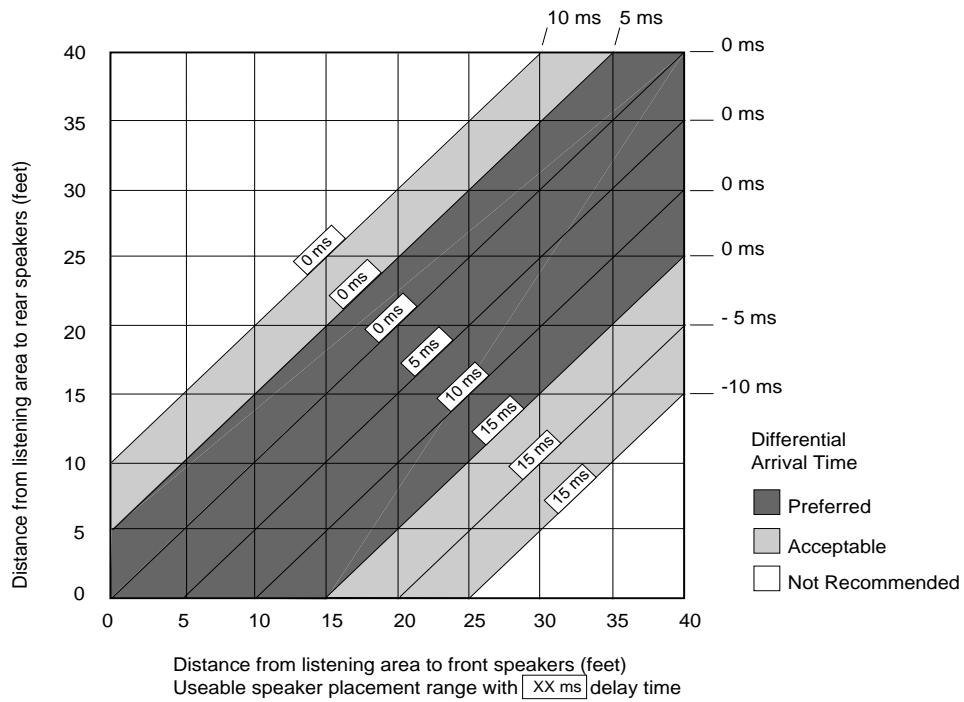

Chart to Set Optimum Surround Delay Time on the P/DD-1500

### Using the P/DD-1500 with Other Processors

Although you will obtain the best results using your P/DD-1500 Digital Surround Decoder with the Parasound P/SP-1500, you also can use the P/DD-1500 with processors made by other manufacturers. The P/DD-1500 can work properly with a different processor it must have a DB-25 input connector or six discrete RCA inputs. Also, since the P/DD-1500's bass management circuitry works in conjunction with the P/SP-1500, the resulting bass management selections will probably be different.

If the host processor you are using has a DB-25 input connector, make sure that the pin configuration is the same as the P/DD-1500. Most manufacturers have followed the protocol established by Dolby Labs and Lucasfilm, the included DB-25 interconnect cable should work properly.

If the host processor is using RCA input jacks, you will have to use a special interconnect cable with a DB-25 connector on one end and 6 RCA plugs on the other. Many cable manufacturers have developed an interconnect to accomplish this task. Contact your Parasound Dealer for more information about using the P/DD-1500 with a different host processor.

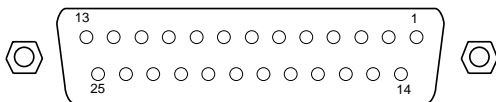

Pin	Assingment	Pin	Assignment
1	Left Positive	14	Left Ground
2	Center Positive	15	Center Ground
3	Right Positive	16	Right Ground
4	Subwoofer Positive	17	Subwoofer Ground
5	Left Surround Positive	18	Left Surround Ground
6	Right Surround Positive	19	Right Surround Ground
7,8,20	Unused	21	Re-EQ
9, 10	Shield Drains	22	Shield Drains
11	Remote Trigger C	23	Remote Trigger Ground
12	Decoder Configuration	24	Logic Ground
13	Remote trigger A	25	Remote Trigger Ground

DB-25 Connector and Pin Assignment Chart

## Maintaining Your P/DD-1500

Your P/DD-1500 requires no periodic maintenance and has no user serviceable parts inside. To avoid the risk of electric shock, do not remove the top cover. Clean the chassis with a soft cloth moistened only with glass cleaner or water; never use solvents or abrasives. Inspect the batteries in the remote control annually and remove them if you do not plan on using the unit for extended periods of time.

## P/DD-1500 Troubleshooting Guide

### No Power

Make sure the AC cord is properly seated in the IEC AC receptacle on rear panel.

### No Output to One or All Channels

Make sure that P/DD-1500 indicators are on.

Check power amplifier(s).

Check source material encoding

*If the **Lock** LED is on:*

Check DB-25 connection between the P/SP-1500 and P/DD-1500

Check connections between P/SP-1500 and amplifiers

*If the **Lock** LED is not on:*

Insure that a digital source is connected and playing

### Problems Selecting Desired Processing Mode

Check source material encoding to make sure it can be player in the selected mode

If the material was encoded in 5.1 channel Dolby Digital, you can only select Dolby Digital or stereo

If the material was not recorded in two channel or Dolby Surround, you can only select Dolby Digital

### Hum in Speakers

Check for a grounding problem with the cable TV system; call your cable operator or installer.

Consider installing a cable isolation device such as the Video Link #634 or the Mondial Magic

### Lights on Front Panel are Working, but No Control Via Remote Control or Front Panel.

The microprocessor within either or both the P/DD-1500 or P/SP-1500 may have "locked up" due to an AC voltage spike. Remove power cord from outlet for 30 seconds and plug it back in.

Check to make sure that AC outlet is always live and not switched off

### Remote Control Won't Work

Check for front panel operation to verify problem is not with P/DD-1500 unit itself

Check remote batteries

Check for interference from sunlight or neon, halogen, or fluorescent room lighting

### If All Else Fails

If you cannot get your P/DD-1500 to operate properly after referring to the troubleshooting guide, call your Parasound dealer or Parasound Technical Service. We may be able to suggest other diagnostic tests you can easily perform. If we determine that your P/DD-1500 should be returned to Parasound or an Authorized Parasound Warranty Center for inspection and possible servicing, call us for the phone number and location of a warranty center near you. If you choose to send it to Parasound, contact us to obtain a Return Authorization (RA) number. You will be asked to repack the unit in its original packaging *plus* the additional outer box for protection during transit. The Return Authorization number must be clearly marked on the outer carton only. You should ship the unit by UPS with adequate insurance. You must also include a copy of your purchase receipt to verify your ownership and purchase date.

Units that arrive without your specific Return Authorization number, without a suitable shipping carton or evidence of improper internal packing must be refused. We do not accept collect shipments. After repair under warranty, the unit will be returned to you via prepaid UPS. In the case of an out of warranty repair, contact us and we will advise you of the repair and shipping charges before you ship the unit to us. The same packaging and RA number requirements apply.

## P/DD-1500 Specifications

### Frequency Response

Front	5 Hz-20 kHz
Surrounds	5 Hz-20 kHz (without filter)
Surrounds	100 Hz-20 kHz (with filter)
Center (Small)	100 Hz-20 kHz
Center (Large)	5 Hz-20 kHz
Low Frequency Effects	5 Hz-20 kHz (without filter)
	5 Hz-120 Hz (with filter)

### Harmonic Distortion

Front	< 0.002 %
Center	< 0.002 %
Surrounds	< 0.002%
Low Frequency Effects	< 0.002 %

### IM Distortion

(1 kHz 1V Output)	
All Channels	< 0.03 %

### Signal to Noise Ratio

(A-Weighted)	
Front	92 dB
Center	92 dB
Rear	92 dB
Low Frequency Effects	92 dB

### Dimensions

19" wide x 3 1/2" high x 13" deep 4 1/8" high with feet

### Weight

17 lb

### Power Requirements

110 V - 120 V 60 Hz AC, 19 W

### Special Features

< RF and Three Digital Inputs	< Zoran 38500 AC-3 Decoder Chipset
< Unified Remote Control	< Low Jitter Crystal CS8412 Digital Receiver
< Built-In RF Demodulator	< 20 Bit Burr-Brown PCM-63-J DACs for L,C,R
< Dolby Digital Decoding	< 20 Bit Burr-Brown PCM-1702 DACs for LS,RS, LFE
< 20 Bit Digital Filtering	< Digital Pro Logic Processing
< 20 Bit D to A Converters	< Separate Left and Right Outputs
< Dialog Normalization	< Precision Resistors and Capacitors
< Lucasfilm Re-Equalization	< External IR Remote Control Jack
< Bass Management Circuitry	< Silver Plated Internal Wiring
< Independent Regulated Power Supplies	< Precision Double Shielded DB-25 Interconnect Cable
< Adjustable Surround Delay Times	< Heavy Duty Two Rack Space Chassis
< Adjustable Center Channel Delay	< 32,000 µF Main Power Supply
< Independent LS, RS Bass Filter	< Audiophile IEC AC Cord

*Specifications and features subject to change without notice*

## Parasound Limited Warranty (USA only)

Your Parasound P/DD-1500 is covered by a limited warranty against defects in materials and workmanship for a period of two years from date of purchase. This warranty is provided by the Parasound dealer where the unit was purchased. Warranty repair will be performed only when a copy of your purchase receipt is presented to validate your ownership, date of purchase and authorized status of the selling dealer. Defective parts will be repaired or replaced without charge by your authorized dealer's store or the location designated by your dealer that is authorized to service Parasound equipment. Additional information is available by calling or writing to the Service Manager, Parasound Products, Inc. at the address below. Charges for unauthorized service and transportation costs are not reimbursable under this warranty.

This warranty becomes void if the product has been damaged by alteration, misuse, accident or neglect. Alteration includes any removal or defacement of its serial number. This warranty becomes void if unit has been connected or operated contrary to printed instructions. The warrantor assumes no liability for property damage or any other incidental or consequential damage whatsoever which may result from the failure of this product. Any and all warranties of merchantability and fitness implied by law are limited to the duration of this expressed warranty.

Some states do not allow limitations on how long an implied warranty lasts, so the above limitations may not apply to you. Some states do not allow the exclusion or limitation of incidental or consequential damages, so the above limitation or exclusion may not apply to you.

This warranty gives you specific legal rights; you may also have other rights which vary state by state.



Manufactured under license from Dolby Laboratories. "Dolby", "Pro Logic", and the double-D symbol are trademarks of Dolby Laboratories Confidential Unpublished Works. © 1992-1997 Dolby Laboratories, Inc. All Rights Reserved.



Manufactured Under License from Lucasfilm Limited. U.S. Patent numbers 5,043; 5,189; and 5,222,059. Foreign patents pending.



# PARASOUND

*affordable audio for the critical listener*

*Parasound Products, Inc. 950 Battery Street, San Francisco, CA 94111  
415-397-7100 / FAX 415-397-0144*

© 1997 Parasound Products, Inc.



## Free Manuals Download Website

<http://myh66.com>

<http://usermanuals.us>

<http://www.somanuals.com>

<http://www.4manuals.cc>

<http://www.manual-lib.com>

<http://www.404manual.com>

<http://www.luxmanual.com>

<http://aubethermostatmanual.com>

Golf course search by state

<http://golfingnear.com>

Email search by domain

<http://emailbydomain.com>

Auto manuals search

<http://auto.somanuals.com>

TV manuals search

<http://tv.somanuals.com>