ATD Actuator[®]

Automatic Door Drive

Model 50 ATD-313186

Operating and Installation Instructions



**Milwaukee Protective Covers
2300 South Calhoun Road
New Berlin, WI 53151**

**Phone: 414-906-4000
Fax: 414-906-4100**

© 1998 Milwaukee Protective Covers
V2.0
www.MPCovers.com

Contents

1	Explanation of symbols	4
2	General Safety Instructions	4
2.1	Correct Use	5
2.2	Design and Installation Personnel Requirements.....	5
2.3	General Information and MPC™ Liability.....	5
3	Theory of Operation.....	6
4	Design Information.....	7
4.1	Mechanical	7
4.1.1	The Door.....	7
4.1.2	Installation Position.....	7
4.1.3	Installation.....	8
4.2	Electrical	9
4.2.1	Main Power Connection.....	9
4.2.2	Control Connection	10
5	Start-up Procedure.....	10
5.1	Preparation.....	10
5.2	Start-up	11
6	Check List for Functional Tests.....	11
7	Error Diagnosis.....	13
8	Hardware Error Displays	14
9	Standard Input Functions	15
10	Standard Output Functions.....	17

11	Operation.....	19
11.1	Calibration Run.....	19
11.2	Door Movements	20
11.3	Reversing Motion.....	20
12	Memory and System Layout.....	21
13	Technical Data.....	22
14	Electrical Wiring Diagram.....	24
15	Physical Dimensions.....	25
16	Trouble Shooting Guide.....	26

1 Explanation of symbols



This symbol warns of general hazards and of possible damage to the equipment.



This symbol warns of dangerous electrical voltages or current

2 General Safety Instructions

Before beginning installation or start-up, read and follow these instructions. Damage to the unit and personal injury may result from not following these instructions.



Keep fingers away from all moving parts. Be especially careful to install guards or shield to protect personnel from the moving drive belt and pulleys.



- Be sure the electrical power is disconnected and locked-out when working on the ATD 50 Actuator[®].
- Install the electrical cables and power only after the mechanical installation of the unit.
- Turn on the power to the ATD 50 Actuator[®] only after all internal cables are connected. Do not connect cables while the unit is powered.
- Always use the correct tools for installation and repair.

2.1 Correct Use

The ATD 50 Actuator[®] is designed for operating automatic doors on machine tools and industrial equipment. It is intended to automatically open and close doors, detect obstructions, and hold the door when closed. Vertical doors must be installed using a counter-weight system since the ATD 50 Actuator[®] is not intended to lift or hold the weight of a door.

Any other use for the ATD 50 Actuator[®] is the judgement and risk of the installer.



The brake on the ATD 50 Actuator[®] is intended to help prevent accidental opening of the door. The brake is not an absolute positive lock and can be overcome by a strong pull of the door. The machine designer and/or installer must decide if additional positive latches are required to insure proper machine safety.

Use the ATD 50 Actuator[®] system only when it is operating properly and as designed. Any problems or malfunctions should be repaired immediately. The safety systems of the ATD 50 Actuator[®] unit depend upon correct operation.

2.2 Design and Installation Personnel Requirements

The design and installation of the guard door system, including the ATD 50 Actuator[®] must be completed by qualified personnel with training and experience in the area of power-operated doors. The personnel must be familiar with relevant work safety regulations, accident prevention guidelines, and generally accepted technical practices.

2.3 General Information

The operating, maintenance, and installation instructions provided by Milwaukee Protective Covers must be observed. The drive must be maintained and repaired only by qualified technicians who are familiar with the ATD 50 Actuator[®] and have been instructed about the possible dangers.

2.3 continued on next page

2.3 General Information (cont.)

The purchaser, designer, and/or installer is responsible to insure the correct and safe application of the ATD 50 Actuator®. These personnel must insure that all Federal, State, and Local laws and regulations regarding workplace safety are observed. OSHA and other safety regulations must be observed when completing an installation.

Milwaukee Protective Covers is not responsible for incidental and/or consequential damages resulting from the use or application of the ATD 50 Actuator®. Our maximum liability under warranty is for only the cost of the product sold. Milwaukee Protective Covers makes no claims for merchantability or fitness of use for specific machine guarding applications. The purchaser, designer, and/or installer of the ATD 50 Actuator® must decide if the drive is applicable to a given machine application. In addition, Milwaukee Protective Covers specifically declines any responsibility for damage or injury resulting from unauthorized changes to the drive, including software parameter changes. No employee of Milwaukee Protective Covers is authorized to modify this warranty without the specific written approval of a company officer.

3 Theory of Operation

The ATD 50 Actuator® is controlled using a built-in microprocessor computer. The microprocessor is programmed to provide optimum motion control and safe response to obstructions. Internal parameters can be changed by authorized service personnel to customize the installation. The software can be modified for each installation.

The ATD 50 Actuator® is completely self-calibrating. Upon power-up, the unit automatically adjusts to the opening width of the machine. During the OPEN and CLOSE motion, the unit finds the end-stop positions of the door. Therefore, the door width is not limited in any way.

The internal drive motor is operated by a variable frequency converter which provides the optimal speed and torque for each movement. The motor speed and torque are continuously monitored thereby providing a sensitive and accurate electronic reversing feature (see Section 11.3).

4 Design Information

4.1 Mechanical

All components in the system must be designed and installed to withstand the forces produced by the system. This includes the door itself, all mounting brackets, the idler pulley, the connector between the door and belt, and the door end stops.

Maximum tensile force of the belt	30 lbs (130 N)
Weight of the ATD 50 Actuator[®] unit	31 lbs (14Kg)

4.1.1 The Door

The door must have fixed positive stops at each end of travel. The stops must be able to withstand the maximum pressure of the driving force (30 lbs /130 N).

Smooth door movement is the most important criteria to insure correct operation. The door should have a consistent drag force over its complete travel. The door guides should provide as low a drag resistance as possible. This will insure trouble-free operation and will increase the drives' sensitivity to any obstructions.

4.1.2 Installation Position

The ATD 50 Actuator[®] can be installed in any position and any orientation according to the specific application. The drive belt, idler pulley, and ATD 50 Actuator[®] should be installed so that the moving parts do not touch or rub on any other part of the machine. Also, the drive pulley and idler must be properly aligned to insure correct belt travel. Failure to align the drive belt properly will result in excessive belt wear and shortened belt life.

The ATD 50 Actuator[®] unit and the drive belt should be installed outside the area of contamination. If the unit must be installed inside the area of contamination, the drive belt must be protected from chips, coolants, or other debris.

4.1.3 Installation

The ATD 50 Actuator[®] internal frame is mounted into the metal enclosure with 6 screws. (There are two screws on the back of the unit and four button-head cap screws on the top.) For installation, only the four screws on the top OR the two screws on the back should be used.



Never loosen all 6 screws at the same time! Otherwise the internal frame will be loose inside the metal housing. If the internal frame is allowed to move inside the metal housing, the drive shaft can be damaged by scraping against the sealing elements.



Under no circumstances should the large hexagonal screw on the drive pulley be loosened!

4.2 Electrical

Internal View of ATD 50 Actuator

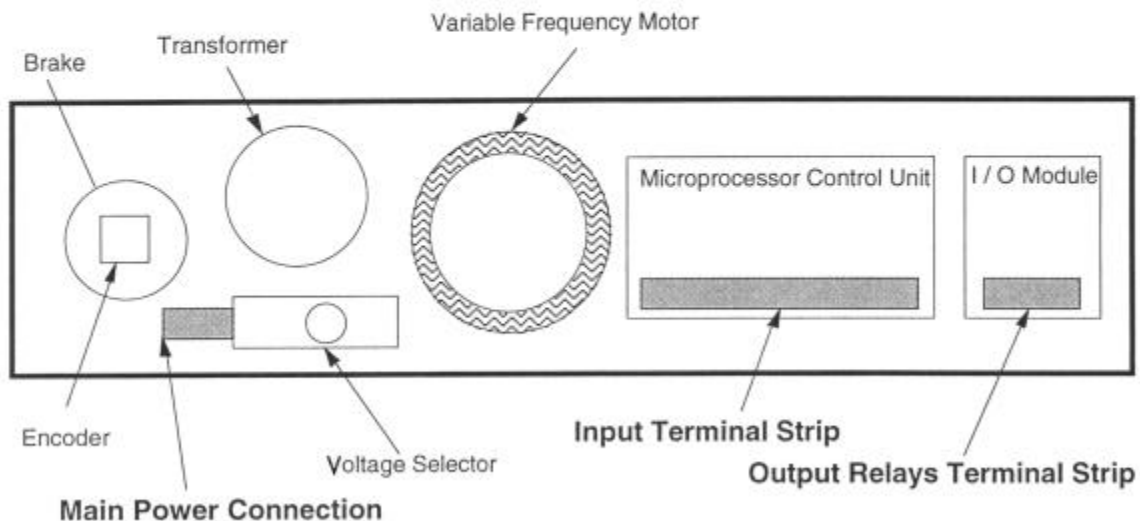

4.2.1 Main Power Connection

The main power supply can be switched between 115 volts and 230 volts and with 50 or 60 Hz AC power. There is an internal switch on the main power connection to select 115V or 230V.



The main power must be externally protected with a 10 amp fast-blow fuse and a system disconnect.



Verify that the power selection switch is set to the correct voltage before start-up!

4.2.2 Control Connection

The ATD 50 Actuator® has a versatile microprocessor controller that interfaces with the machine control unit. The parameters are factory-set. However, a knowledgeable service technician can change the parameter settings using the Microsoft Windows® '95 based SERsoft programming software.

Inputs

An input is activated when an input terminal (IN) is connected to ground (GND). This connection must be made using potential-free contacts. No external power supply must be used to activate inputs.

Outputs

Six (6) potential free output relays are provided. Three (3) relays are wired as normally open and three (3) are wired as normally closed. (See page 24)

5 Start-up Procedure

5.1 Preparation

Prepare the ATD 50 Actuator® by completing the following steps:

- Mount the drive box on a rigid base in a suitable position.
- Install the idler pulley to a rigid base on the machine.
- Cut the drive belt to length and splice together using the supplied clamp.
- Tension the drive belt by adjusting the idler pulley.
- Connect the drive belt to the door by fixing a bracket from the clamp to the door. End-user must supply their own bracket.
- Verify that the door runs freely to both end-stops.
- Connect the input and output control cables and attach to the machine controller.
- Connect the main power cable. Do not apply power at this time!

The drive is now ready!

5.2 Start-up

- Check the main power voltage selection switch for proper supply voltage (230V / 115V)
- Check the control connections and verify they are correctly installed



Beware of Electrical Voltages!

- Switch on the main power supply to the drive.
- Start the calibration run (see section below).
- Check and test all functions to be used.
- If required, re-adjust door-specific parameters (opening and closing speeds, braking distance, etc.) using the SERsoft programming software.
- Test the complete system.

6 Check List for Functional Tests

During the functional tests the door travel path must be free of obstructions. The only limits to door travel should be the two end-stops. Test the unit according to the following steps:

TEST 1: POWER-UP

ACTION: Energize the main power to the ATD 50 Actuator®
EXPECTED BEHAVIOR: No door movement.
Green LED on the Control Board illuminates.
Door is freely moveable.
No errors displayed on LED' at terminals D5 - D9 (if installed).
No errors displayed in the SERsoft Diagnostic Display.

TEST 2: CALIBRATION RUN

ACTION: Apply momentary or maintained contact between OPEN input (A2) and Ground (A1).
EXPECTED BEHAVIOR: Door moves slowly to open position and pushes against end-stop.
Open position is now set in the microprocessor.
ACTION: Apply momentary or maintained contact of CLOSE input (A7) and Ground (A1).
EXPECTED BEHAVIOR: Door moves slowly to closed position and pushes against end-stop.
Closed position is now set in the microprocessor.

6 Check List for Functional Tests (cont.)

TEST 3: OPTIMIZE MOVEMENTS

ACTION: Operate the door for two (2) complete open and close movements.

EXPECTED BEHAVIOR: Door should open and close normally. The microprocessor measures the torque and sets the internal speed and torque references. These references are used as safety thresholds for detecting obstructions.

NOTE: The safety reversing function is not active during the first two (2) open and close cycles! See Sec. 11.1.

TEST 4: CHECK ALL FUNCTIONS

ACTION: Activate all connected functions and options such as CNC, PLC, pushbuttons, photoeyes, etc.

EXPECTED BEHAVIOR: Door should operate normally per feature definitions.

7 Error Diagnosis

There are 10 error conditions that can be detected by installing LED's to specific "B TERMINAL STRIP" outputs inside the ATD 50 Actuator®.

		Error Number									
		2	3	9	10	11	12	13	16	29	30
LED Number	B5		✱	✱		✱		✱		✱	
	B6	✱	✱		✱	✱					✱
	B7						✱	✱		✱	✱
	B8			✱	✱	✱	✱	✱		✱	✱
	B9								✱	✱	✱

The errors are indicated

according to the following code:

Software Error Number

- 2 Calibration run is taking place. Wait until door is closed for error to clear
- 3 Main power failure.
- 9 Microprocessor error or drive type not specified. Contact Factory.
- 10 Emergency stop activated.
- 11 Motor overheated. Allow motor to cool for reset or Contact Factory.
- 12 Power module faulty or low mains voltage.
- 13 No movement is detected from the door. Possibly the encoder, cable, motor, or belt is defective. Door is possibly blocked.
- 16 Door is in reversing mode because it has encountered an obstruction. Wait until door is closed.
- 29 External reversing on closing.
- 30 External reversing on opening.

NOTE: The software errors can also be detected using the SERsoft programming software. The errors are displayed in the Error Window in the Diagnostic Menu.

8 Hardware Error Displays

The microprocessor controller has a red and green LED light in the lower right corner. The LED lights indicate the general status of the microprocessor.

GREEN LED

The microprocessor controller is operating correctly.

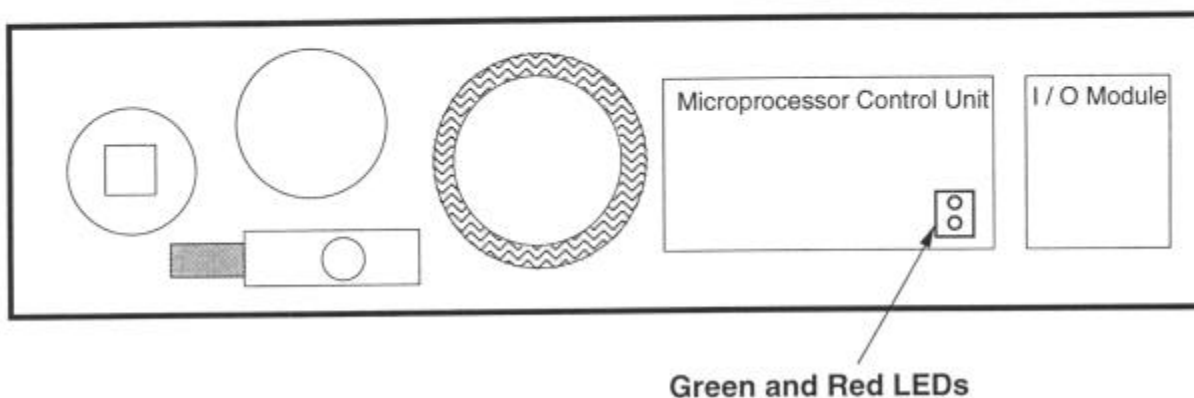

RED LED

Any of the following conditions:

- A software error is detected
- The emergency stop is active
- E-Stop Jumper connection between terminals D1 & D2 is missing
- The motor is overheated
- Controller Failure

9 Standard Input Functions

The ATD 50 Actuator® can accept either momentary or maintained contacts. The factory default is momentary. If additional safety requirements are desired, you can specify MAINTAINED CONTACT for the input signals. Maintained Contact Signals can be programmed in the Basic Functions Menu in the SERsoft programming software.

If you desire to use maintained contacts for input signals, we suggest using the following logic in your PLC or CNC:

The error signals for All Errors (General Error 1 - Relay 1 - E1 to E2) and General Errors (General Error 2 - Relay 4 - E7 to E8) are activated during calibration runs. The maintained contact can be held until the errors clear. In this situation, the machine controller can monitor Relay 1 or 2 and maintain the inputs to A2 and A7 until the errors clear.

OPEN

This command will move the door to the full open position.

Input terminal:	A2
Type of signal:	Momentary or maintained contact A2 to Ground A1.
Active level	Connection is normally open. Close connection to activate.
Calibration run:	After a software reset or a loss of main power, the first portion of the calibration run is started with this command.

CLOSE

This command will move the door to the closed position.

Input terminal:	A7
Type of signal:	Momentary or maintained contact A7 to Ground A1.
Active level	Connection is normally open. Close connection to activate.
Calibration run:	After a software reset or a loss of main power, the second portion of the calibration run is started with this command. The calibration run is completed when the door reaches the closed position.

REDUCED OPEN

This command causes the door to open to a preset position from the closed position only.

Reason for use:	This command is used when a completely opened door is not required. (Operator may wish to access inside of machine briefly).
Input terminal:	C4
Type of signal:	Momentary or maintained contact C4 to Ground A1.
Active level	Connection is normally open. Close connection to activate.

FREE WHEEL

This command releases the internal brake allowing manual door movement.

Reason for use:	This command will release the brake and allow the operator to manually move the door. While this signal is present, no other command will be carried out.
Input terminal:	C7
Type of signal:	Momentary or maintained contact C7 to Ground A1.
Active level	Connection is normally open. Close connection to activate.

REVERSE CLOSING

This command reverses the door movement when closing. The door will reverse direction and move to the full open position.

Reason for use	A secondary safety device such as a ribbon switch or light curtain can be installed into the system. The secondary device would be wired into this command to give a faster REVERSE signal. This is independent from the automatic sensing feature.
Input terminal:	C9
Type of signal:	Momentary or maintained open contact C9-to-Ground A1.
Active level	Connection is normally closed. Open connection to activate.

SET REDUCED OPEN POSITION

This command sets the reduced door open position.

Reason for use:	The reduced open position can be manually set by using the input command at terminal F2. You must be able to manually move the door to the desired position before activating this input command. The distance can be set using the SERsoft programming software.
Input terminal:	F2
Type of signal:	1 second contact of F2 to Ground F1.
Active level	Connection is normally open. Close connection to activate (program the position).

EMERGENCY STOP

This command will instantly stop all door movement.

Reason for use:	To interface to your machine's E-stop circuit.
Input terminal:	D1 & D2
Type of signal:	Momentary or maintained open between D1 and D2.
Active level	Connection is normally closed. Open connection to activate (stop door movement).

10 Standard Output Functions

The output signals are connected to the six (6) relays inside the ATD 50 Actuator®

GENERAL ERROR 1

	This output contains all error messages with the exception of the internal and external reversing motions. This means any problem except an obstruction is present in the door path. (Error numbers 16, 29, & 30 are not active).
Output terminal:	E1 & E2 (Relay 1).
Active level:	Contact is normally open (no error). Closed contact when activated (error present)

REVERSING ERROR / GENERAL ERROR 2

This output is active when the internal and external reversing motions are initiated, usually due to an obstruction. (Error numbers 16, 29, or 30 active).

Output terminal: E3 & E4 (Relay 2).
Active level Contact is normally open (no error).
Closed contact when activated (error present).

DOOR POSITION IS CLOSED

This output is active when the door is in the closed position $\pm 1/8$ inch. The output is active also when the door is manually moved to the closed position.

Output terminal: E5 & E6 (Relay 3).
Active level Contact is normally open.
Closed contact when activated.

DOOR POSITION OPEN

This output is active when the door is in the open position ± 1.5 inch. The output is active also when the door is manually moved to the open position.

Output terminal: I1 & I2 (Relay 4.)
Active level Contact is normally closed.
Open contact when door is in the full open position.

DOOR IS CALIBRATED

This output is active when the door has been calibrated and is ready for normal operation.

Output terminal: I3 & I4 (Relay 5).
Active level: Contact is normally closed.
Open contact when door is calibrated.

Door at Reduced Open Position

This output is active when the door has reached the Reduced Open Position or when the door is in the full open position.

Output terminal: 5 & I6 (Relay 6.)
Active level: Connection is normally closed.
Open connection when activated.

11 Operation

11.1 Calibration Run

The first movements after a power-up or system reset are the self-calibration reference moves. The door travels to each end-stop and records the distance traveled and torque needed for movement. The door can be freely moved before a Calibration Run.

NOTE: The automatic reversing feature is disabled during the calibration cycles!

The calibration cycle must be started by the external input signals. The calibration steps are:

1. Power-up or system reset erases the previous calibration.
2. An OPEN signal must be given to the ATD 50 Actuator® by a momentary or maintained contact from A2 to Ground A1.
3. The door moves slowly to the extreme open end-stop. It pushes against the end-stop with full force, then stops. The open position is now set.
4. A CLOSE signal must be given to the ATD 50 Actuator® by a momentary or maintained contact from A7 to Ground A1.
5. The door moves slowly to the extreme closed end-stop. The door pushes against the end-stop with full force, then stops. The door closed position is now set.

The door must contact the end-stop using the ATD 50 Actuator® power. If the door is interrupted during the calibration cycle, the calibration procedure must be repeated. The calibration cycle must begin with an “OPEN” signal followed by a “CLOSE” signal.



During the calibration run, the drive runs with full torque. The safety reverse feature is disabled and the internal reversing motion is not active!

It is imperative that the machine designer and installer notify all machine operators that the reversing safety feature is not active during the first two OPEN and CLOSE motions after power-up or system reset. During these first movements the ATD 50 Actuator® automatically calibrates itself to determine the required reference torques. Any obstruction is interpreted as “normal” by the controller and is recorded as the required torque at that point of travel.

11.2 Door Movements

- The input signals for OPEN, CLOSE and REDUCED OPEN can be given as momentary or maintained contacts.
- The door moves freely when in the open position. When open, the drive waits for the next input command signal.
- The door is locked with an internal brake **ONLY** when in the closed position. When closed, the door waits for the next input command. The brake can be released by giving a FREE WHEEL command using input A1 to C7 or an OPEN command using input A1 to A2.
- If the door is opened to the reduced position, it can be fully opened with the OPEN command or closed and locked with the CLOSE command.

11.3 Reversing Motion

Obstructions are detected using three variables: 1) Stall Time 2) Speed and 3) Motor Torque. An obstruction is assumed if 1) The door stalls for more than one second, 2) The speed of travel is slower than a predetermined threshold, and 3) The torque needed is greater than the reference torque.

If an obstruction is encountered during a CLOSE movement, the door reverses direction and moves to the full open position. The ATD 50 Actuator® waits until it receives a new CLOSE command.

If an obstruction is encountered during an OPEN movement, the door reverses direction, moves about one inch (25 mm) away from the obstruction and stops. The ATD 50 Actuator® waits until it receives a new command.

During the next motion after encountering an obstruction, the door moves at 50% speed toward the obstruction point. The motor torque variable is disabled during this “second attempt”. Therefore, the ATD 50 Actuator® is less sensitive to an obstruction. If no obstruction is encountered, then the motion continues as normal and the three variables are monitored again.

12 Memory and System Layout

The heart of the ATD 50 Actuator® is a Motorola 68HC11 microprocessor. The microprocessor accesses an EPROM and EEPROM for specific software instructions and parameters. The general software instructions are stored in the EPROM. The application and door specific parameters are stored in the EEPROM.

EPROM

The universal operating software with general functions and instructions is stored in the EPROM. These instructions, alone, are not enough to correctly operate the ATD 50 Actuator®.

EEPROM

The application parameters and instructions are stored in the EEPROM. The EEPROM contains all parameters which are entered or modified using the SERsoft programming software. The more specific instructions for the ATD 50 Actuator® are stored in the EEPROM. The parameters and instructions stored in the EEPROM can be saved in a SERsoft programming software file. Contact MPC for more information.

MICROPROCESSOR

The microprocessor follows the general (operational) instructions of the EPROM while accessing the EEPROM for application specific parameters.



After a system-wide initialization all parameters and instructions in the EEPROM are deleted. Only the operating software in the EPROM remains. Therefore, the ATD 50 Actuator® will not operate

A system-wide initialization is started by any one of the following:

- 1) Removing the EEPROM; or
- 2) Selecting the menu "Software Reset" or
- 3) Selecting the menu "Factory Settings" in the SERsoft programming software.

NEVER SPECIFY ÒRETURN TO FACTORY SETTINGSÓ UNLESS THE PARAMETERS HAVE BEEN SAVED IN A SERsoft FILE!

13 Technical data

Connection Voltage	115 / 230V AC (selected with an internal switch) 50 / 60 Hz
Power Consumption	min. 4 W max. 160 W
Motor Nominal Speed	1600 rpm
Motor Nominal Torque	9 inch-lbs (1 Nm)
Maximum Drive Speed	443 rpm
Maximum Tensile Force of Belt	30 lbs (130 N)
Maximum Drive Torque	32 inch-lbs (3.6 Nm)
Absolute Maximum Opening Speed	40 inches / second (1000 mm/sec)
Absolute maximum Closing Speed	40 inches / second (1000 mm / sec)
Maximum Permissible Door Weight (total weight of all leafs)	265 lb (120 kg)
Weight of ATD Actuator [®]	31 lbs (14kg)
Serial Interface	RS-232

Technical Data (cont.)OUTPUTS

Relay:

Contact load	28VDC @ 1A or 120VAC @ 0.5A
Contact protection	Must be externally connected. Required for inductive loads. RC-element for AC loads. Diode (1N4007) for DC load.
Terminals	E1 - 6 & I1 - 6. Refer to electrical wiring diagram.
Available Internal Power Supply	+24VDC
Overload Protection	2.0A Max current (protected by Fuse 1)

Maximum Load for all Output Voltages COMBINED is 12 watts!

Transistor:

Output: Transistor Output	I _{max} = 100mA for error LEDs
Overload protection	Time-limited protection available
Terminals	B5 through 9

Inputs:

Signal Type:	All inputs must be from potential free contacts.
Terminals:	A2 & 7, C4, 7, & 9, D2, F2

14 Electrical Wiring Diagram

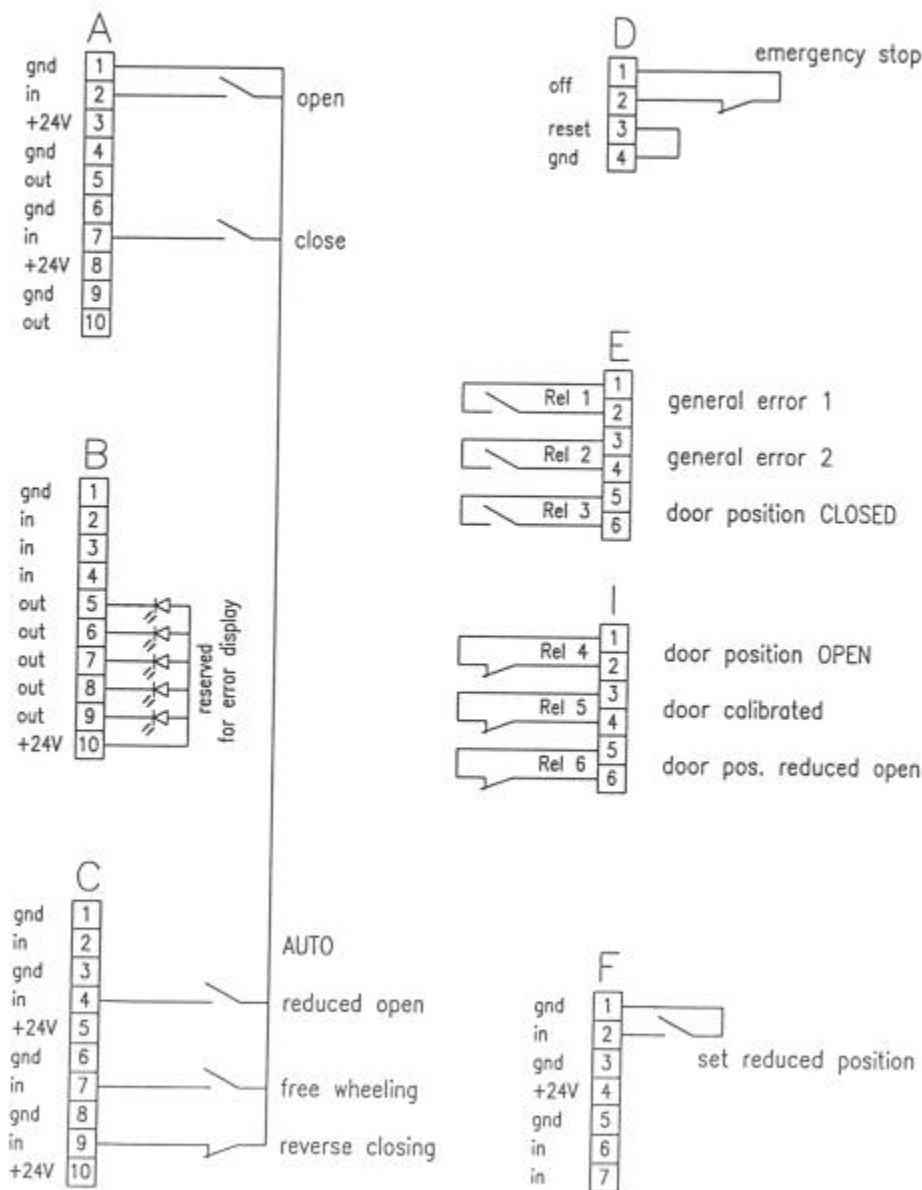

ATD Actuator® Troubleshooting Guide

Symptom	Solutions
Door does not move	<ol style="list-style-type: none">1) Check Power to Unit<ul style="list-style-type: none">• Blown Supply Fuse supplying power to ATD• Power Cable plugged into selector switch inside• Selector switch set to correct voltage (115 or 230 VAC). If wrong voltage is selected the control or power module will be damaged!• Is the supply voltage too high or too low (+/- 10%)2) Correct Wiring<ul style="list-style-type: none">• Correct signals to correct wiring terminals• External wiring error from relay, pushbutton, etc.• Is relay, pushbutton, etc. working correctly• Check to verify that no external voltage is present on the signal wires• The signal wire is properly connected to the terminal• Verify that the wires are not damaged• Is the ribbon cable from the input signal board to the ATD control module (ATD 50 and 101) plugged in properly• Are the quick-connect wire terminals plugged in properly• Are the quick-connect terminals plugged into the correct location <p>Control Module Functioning Properly</p> <ul style="list-style-type: none">• Are all the cables (encoder, brake, output relay module) all plugged into the Control Module• Is the Green LED Lighted (ATD 50 and 101 on Control Module. ATD 100 on Power Module)<ul style="list-style-type: none">• Yes – Go to #2 below• No – Is Red LED Illuminate<ul style="list-style-type: none">• Yes – Emergency Stop is active or there is a problem with the Control / Power Module. Check the Diagnostics Screen for information.

Symptom

Solutions

Door does not move
(continued)

2) Mechanically Related

- Does the door move freely when connected to drive Belt?
 - No - Does the output sheave turn without excessive effort? (The sheave will require some effort to rotate. Sheave will not "spin"!)
 - No – loosen the four screws around the drive sheave up to 1 full turn. Turn output sheave by hand until sheave rotates freely. Retighten all four screws.
 - Yes- does the motor shaft rotate but the drive sheave does not?
 - Belt between the motor to output sheave is either broken or came off the sheaves
 - Is the door too heavy for the ATD?

3) Software Related

- Connect SERsoft and establish ON-LINE Connection. Make sure you are using correct SERsoft version! (V1.2 for ATD 100 and V1.5 for ATD 50 and 101)
 - Check Diagnostics Screen for any errors
 - Verify the correct "Actuator Type" is programmed in the "Basic Functions" screen.
 - ATD 50 – Should display MxP 50 / ATD 50
 - ATD 100 – Should display MxP 100 / ATD 100
 - ATD 101 – Should display MxP 101 / ATD 101

See "Reprogramming ATD Actuator Type" Instructions for Solution

Door "does not stay closed"

- 1) Is there an obstruction present?
- 2) Go to "Motion Control" Screen and check the "End Stop Tolerance" Value?
If the door has a seal that is not compressing consistently, the "End Stop Tolerance" value may need to be increased.
- 3) "Reverse Closing" input missing
ATD 50 / 101 - Install Jumper between C8 and C9
ATD 100 - Install jumper between H1 and H7

Symptom

Solutions

Door begins to close (or open) but reverses

- 1) Mechanical Observations
 - Check door path for any obstructions such as large debris, chips, tool, “rough” spot in door track, etc.
 - Does door bind or twist when ATD moves door
 - Is door staying in it’s door path and not being “lifted” by ATD drive belt and causing an “obstruction” error

Door nearly fully closed (or open) but reverses

- 1) Incorrect Speed Parameters
 - Check “Diagnostics”
 - Error 1602 or 1603 “Torque Reversing” – ATD Cannot decelerate the door to the desired speed within the designated distance
 - Increase the “Braking Distance” in the “Motion Control” screen AND / OR
 - Decrease the “Opening” or “Closing Speed” in the “Basic Functions” Screen
- 2) Is this an ATD 101?
 - Increase “Braking Distance” to at least 400mm
 - Possible fix - Turn off only the “Speed Lagging” Option in the “Motion Control – Reversing Options” Menu
 - Possible fix - Turn off only the “Force Reversing” Option in the “Motion Control – Reversing Options” Menu

Door moves very short distance and stops. Error 1301 – “Door Opening too small”

- 1) Mechanically Related
 - Is the door mechanically binding such that it cannot move more than a few inches?
 - Is the door too heavy for the ATD?
 - Did the internal drive belt come off the motor to drive sprocket? (Controller is not sensing any encoder movement)
- 2) Encoder Related problem
 - Is the encoder cable properly connected at both ends?
 - Go to SERsoft Diagnostics – Informations
 - Monitor the Encoder / Door Position information and determine if the encoder is sensing door movement. If not, Replace Encoder

Symptom**Solutions**

ATD 50 does not sense an
Obstruction

- 1) Sensitivity was changed from "High" to "Low" or "No".
- 2) Change was made with SERsoft V1.2 to ATD 50 with EPROM T3197. Use SERsoft V1.5 to correct.

Door "Slams or Runs
Slow" against end stop

- 1) "Open End Stop Tolerance" in Motion Control set to a small distance or zero
- 2) "Homing in Speed" set too high (slamming) or too low (door moves slowly)
- 3) "Homing in Distance" set too long (door too slow)
- 4) "Homing in Distance" set too short (door slams)
- 5) "Braking Distance" too short
- 6) "Opening Dampening" set to "Hard"
- 7) For ATD 101 ONLY (In opening Direction)
enter the following into DIRCOM: P,130,0,W,31

Free Manuals Download Website

<http://myh66.com>

<http://usermanuals.us>

<http://www.somanuals.com>

<http://www.4manuals.cc>

<http://www.manual-lib.com>

<http://www.404manual.com>

<http://www.luxmanual.com>

<http://aubethermostatmanual.com>

Golf course search by state

<http://golfingnear.com>

Email search by domain

<http://emailbydomain.com>

Auto manuals search

<http://auto.somanuals.com>

TV manuals search

<http://tv.somanuals.com>