

\$1.00

OWNER'S GUIDE

ASSEMBLY • OPERATION • MAINTENANCE • PARTS

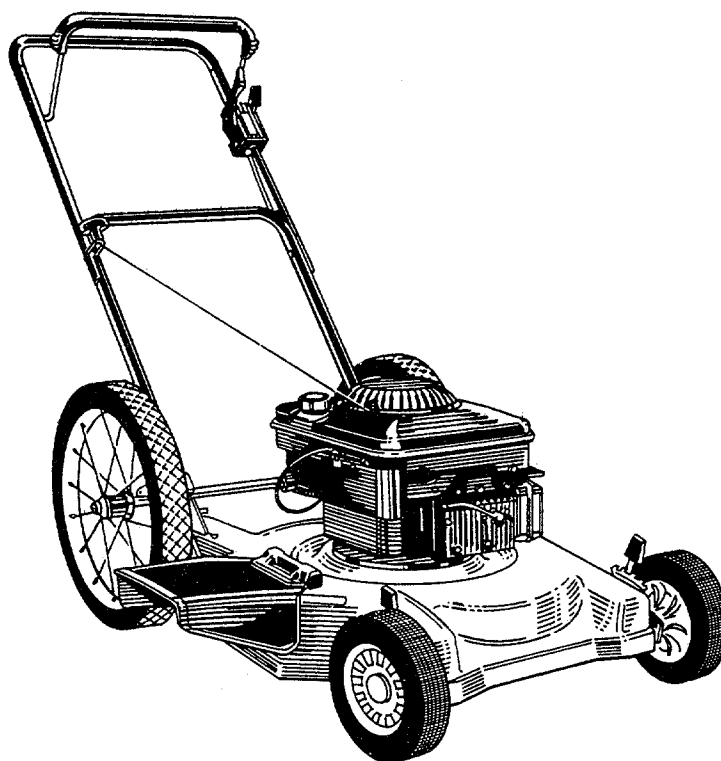

22"
ROTARY
MOWER

Model Number
110A508R000
GB 86 CATCHER

Important: Read Safety Rules and Instructions Carefully

INDEX

Slope Gauge	3
Contents of Hardware Pack	4
Rules for Safe Operation	5
Assembly	6
Controls	9
Operation	9
Adjustments	10
Lubrication	11
Maintenance	12
Off-Season Storage	12
Trouble Shooting Guide	13
Repair Parts	14
Parts Information	Back Cover

Dear Customer,

So often throughout the year we are all in a rush to meet our daily obligations.

However, we at MTD Products Inc are taking a quick moment out to say...

"Thank you for your business."

Sincerely,
MTD PRODUCTS INC



INSTRUCTIONS GIVEN WITH THIS SYMBOL ARE FOR PERSONAL SAFETY. BE SURE TO FOLLOW THEM.

NOTE: The engine is not under warranty by the mower manufacturer... If repairs or service is needed on the engine, please contact your nearest authorized engine service outlet. Check the "Yellow Pages" of your telephone book under "Engines—Gasoline."

Find It Fast
In The
Yellow Pages



NOTE

This instruction manual covers various models and all specifications shown do not necessarily apply to your model. Specifications subject to change without notice or obligation.

NOTE: The use of any accessory on this Rotary Mower other than those manufactured by the mower manufacturer is not recommended. GRASS CATCHER Model ~~127~~ is available as optional equipment for the mower shown in this manual.

706-6B86



WARNING: To reduce the risk of injury, do not operate mower unless rear trailing shield and guard or entire grass catcher is in its proper place.

NOTE: Under normal usage bag material is subject to wear and should be checked periodically. Be sure any replacement bag complies with the mower manufacturer's recommendations.

WARNING: This unit is equipped with an internal combustion engine and should not be used on or near any unimproved forest-covered, brush-covered or grass-covered land unless the engine's exhaust system is equipped with a spark arrester meeting applicable local or state laws (if any). If a spark arrester is used, it should be maintained in effective working order by the operator.

In the State of California the above is required by law (Section 4442 of the California Public Resources Code). Other states may have similar laws. Federal laws apply on federal lands. A spark arrester for the muffler is available through your nearest engine authorized service dealer.

USE THIS SHEET AS A GUIDE TO DETERMINE SLOPES WHERE YOU MAY NOT OPERATE SAFELY.

SLOPE GAUGE

(Keep this sheet in a safe place for future reference.)

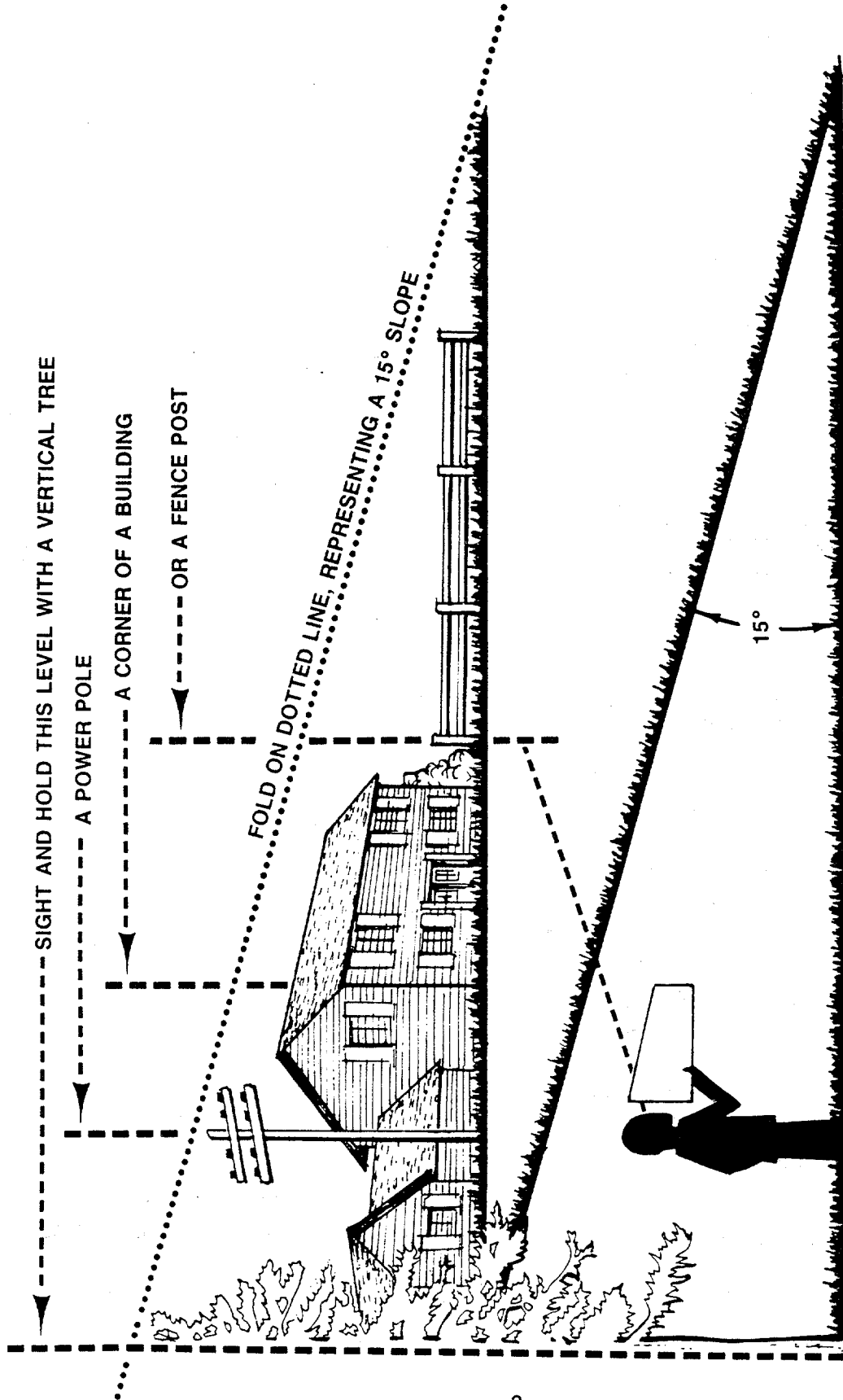









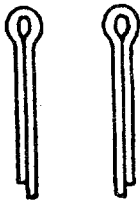
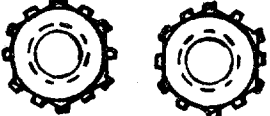
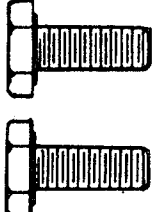

Do not mow on inclines with a slope in excess of 15 degrees (a rise of approximately 2½ feet every 10 feet). A riding mower could overturn and cause serious injury. If operating a walk-behind mower on such a slope, it is extremely difficult to maintain your footing and you could slip, resulting in serious injury.

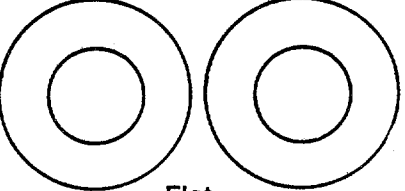
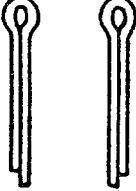
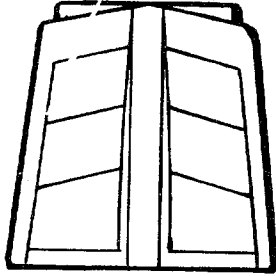
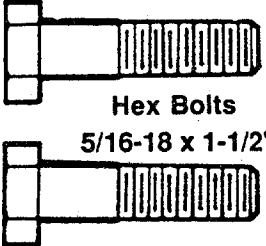
Operate RIDING mowers up and down slopes, never across the face of slopes.

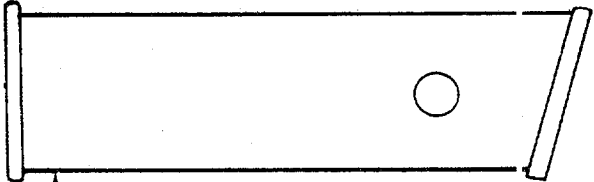
Operate WALK-BEHIND mowers across the face of slopes, never up and down slopes.

CONTENTS OF HARDWARE PACK

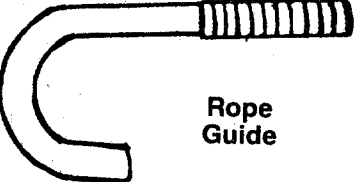
Remove this sheet from your owner's manual and lay the hardware on the illustration for identification purposes. After assembly, keep the Slope Gauge which is on the reverse side of this sheet for future use.
(Hardware pack may contain extra items which are not used on your unit.)

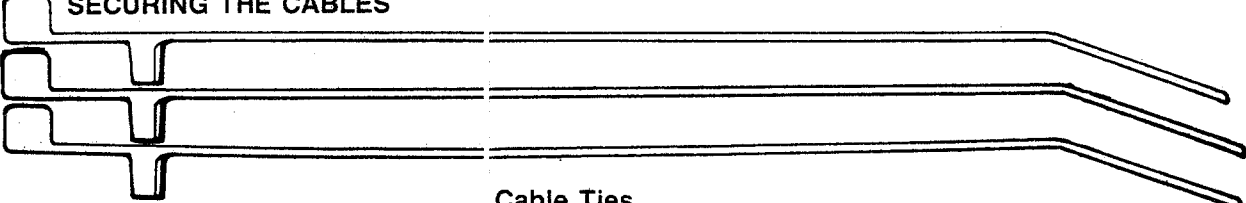

<p>A ATTACHING THE LOWER HANDLE</p>  <p>Cotter Pins</p>	<p>F INSTALLATION OF REAR WHEELS AND STABILIZER</p>  <p>Hex Nuts 3/8-16 Thread (With Washers)</p>  <p>Hex Bolts 1/4-20 x .62"</p>  <p>Split Washers 1/4" I.D.</p>  <p>Hex Nuts 1/4-20 Thread</p>  <p>Flat Washers 1/2" I.D.</p>  <p>Cotter Pins</p>  <p>Adjustor Knobs Four (4) Required</p>
<p>B ATTACHING THE UPPER HANDLE</p>  <p>Hex Bolts 5/16-18 x 1-1/2"</p>  <p>Hex Nuts 5/16-18 Thread</p>  <p>Split Washers 5/16" I.D.</p>	
<p>C ATTACHING THE THROTTLE CONTROL</p>  <p>Cable Bracket</p>  <p>Hex Bolt 1/4-20 x 2" Long</p>  <p>Split Washer 1/4" I.D.</p>  <p>Hex Nut 1/4-20 Thread</p>	
<p>E ATTACHING THE STARTER ROPE</p>  <p>Rope Guide</p>  <p>Hex Nut 1/4-20 Thread (With Washer)</p>	
<p>D SECURING THE CABLES</p>  <p>Cable Ties</p>	



Cut Along This Line

IMPORTANT

RULES FOR SAFE OPERATION

 THIS SYMBOL POINTS OUT IMPORTANT SAFETY INSTRUCTIONS WHICH, IF NOT FOLLOWED, COULD ENDANGER THE PERSONAL SAFETY AND/OR PROPERTY OF YOURSELF AND OTHERS. READ AND FOLLOW ALL INSTRUCTIONS IN THIS MANUAL BEFORE ATTEMPTING TO OPERATE YOUR LAWN MOWER. FAILURE TO COMPLY WITH THESE INSTRUCTIONS MAY RESULT IN PERSONAL INJURY. WHEN YOU SEE THIS SYMBOL—  **HEED ITS WARNING.** 

DANGER

Your lawn mower was built to be operated according to the rules for safe operation in this manual. As with any type of power equipment, carelessness or error on the part of the operator can result in serious injury. If you violate any of these rules, you may cause serious injury to yourself or others.

TRAINING

1. Read this owner's guide carefully in its entirety before attempting to assemble or operate this machine. Be completely familiar with the controls and the proper use of this machine before operating it. Keep this manual in a safe place for future and regular reference and for ordering replacement parts.
2. Your rotary mower is a precision piece of power equipment, not a plaything. Therefore, exercise extreme caution at all times.
3. Never allow children to operate a power mower. Only persons well acquainted with these rules of safe operation should be allowed to use your mower.
4. Keep the area of operation clear of all persons, particularly small children and pets. Stop engine when they are in the vicinity of your mower to help prevent blade contact or thrown object injury. Although the area of operation should be completely cleared of foreign objects, an object may have been overlooked and could be accidentally thrown by the mower in any direction and cause serious personal injury to the operator or any others allowed in the area.

PREPARATION

1. Thoroughly inspect the area where the equipment is to be used. Remove all stones, sticks, wire, bones and other foreign objects which could be picked up and thrown by the mower in any direction and cause serious personal injury to the operator or any others allowed in the area.
2. Always wear safety glasses or eye shields during operation or while performing an adjustment or repair, to protect eyes from foreign objects that may be thrown from the machine in any direction.
3. Wear sturdy, rough-soled work shoes and close-fitting slacks and shirts to avoid entanglement in the moving parts. Never operate a unit in bare feet, sandals, or sneakers.
4. Check the fuel before starting the engine. Gasoline is an extremely flammable fuel. Do not fill the gasoline tank indoors, while the engine is running, or until engine has been allowed to cool for two minutes after running. Replace gasoline cap securely and wipe off any spilled gasoline before starting the engine as it may cause a fire or explosion.
5. Disengage the self-propelled mechanism or drive clutch on units so equipped before starting the engine.
6. The blade control handle is a safety device. Never attempt to bypass its operation. Doing so makes the safety device inoperative and may result in personal injury through contact with the rotating blade. The blade control handle must operate easily in both directions.
7. Never attempt to make a wheel or cutting height adjustment while the engine is running.
8. Never operate the equipment in wet grass. Always be sure of your footing. A slip and fall can cause serious personal injury. Keep a firm hold on the handle and walk, never run. Mow only in daylight or in good artificial light.

9. For your safety, use the slope gauge included as part of this manual to measure slopes before operating this unit on a sloped or hilly area. If the slope is greater than 15° as shown on the slope gauge, do not operate this unit on that area or serious injury could result.

OPERATION

1. Do not change the engine governor settings or overspeed the engine. Excessive engine speeds are dangerous.
2. Do not put hands or feet near or under rotating parts. Keep clear of the discharge opening at all times as the rotating blade can cause injury.
3. Stop the blade when crossing gravel drives, walks or roads.
4. After striking a foreign object, stop the engine, remove the wire from the spark plug, and thoroughly inspect the mower for any damage. Repair the damage before restarting and operating the mower.
5. If the equipment should start to vibrate abnormally, stop the engine and check immediately for the cause. Vibration is generally a warning of trouble.
6. Shut the engine off and wait until the blade comes to a complete stop before removing the grass catcher or unclogging the chute. The cutting blade continues to rotate for a few seconds after the engine is shut off. Never place any part of the body in the blade area until you are sure the blade has stopped rotating.
7. Before cleaning, repairing or inspecting, make certain the blade and all moving parts have stopped. Disconnect the spark plug wire, and keep the wire away from the spark plug to prevent accidental starting.
8. Do not run the engine indoors.
9. Mow across the face of slopes, never up-and-down. Exercise extreme caution when changing direction on slopes. Do not mow excessively steep slopes. Always be sure of your footing. A slip and fall can cause serious personal injury.
10. Never operate mower without proper guards, plates or other safety protective devices in place.

MAINTENANCE AND STORAGE

1. Check the blade and engine mounting bolts at frequent intervals for proper tightness.
2. Keep all nuts, bolts, and screws tight to be sure the equipment is in safe working condition.
3. Never store the equipment with gasoline in the tank inside of a building where fumes may reach an open flame or spark. Allow the engine to cool before storing in any enclosure.
4. To reduce fire hazard, keep the engine free of grass, leaves, or excessive grease.
5. Check the grass catcher bag frequently for wear or deterioration. For safety protection, replace only with new bag meeting original equipment specifications.

➔ **IMPORTANT:** This unit is shipped **WITHOUT GASOLINE** or **OIL**. After assembly, service engine with gasoline and oil as instructed in the separate engine manual packed with your unit.

➔ **NOTE:** Reference to right or left hand side of the mower is observed from the operating position.

ASSEMBLY INSTRUCTIONS

Tools Required for Assembly

- (1) Pair of Pliers
- (2) 7/16" Wrenches*
- (2) 1/2" Wrenches*
- (1) 9/16" Wrench*
- * Or 6" Adjustable Wrenches.

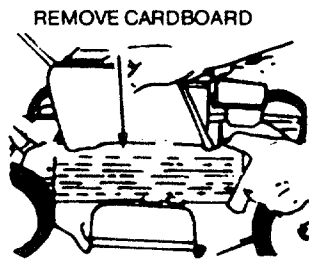

FIGURE 1.

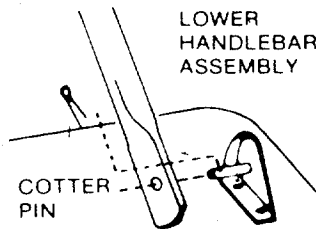

FIGURE 2.

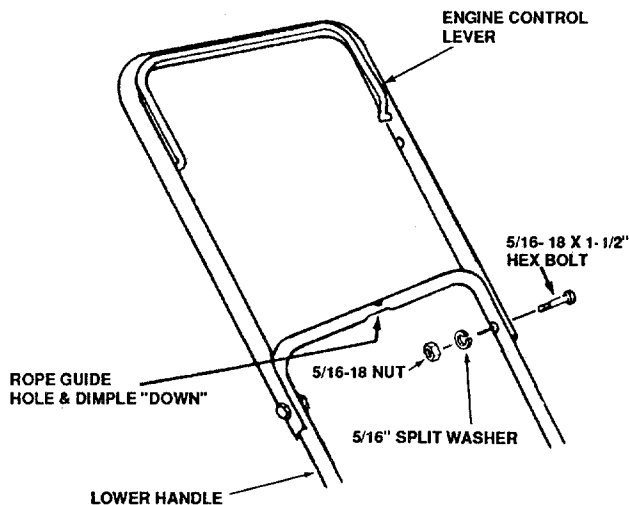

FIGURE 3.

UNPACKING

1. Remove the lawn mower from the carton by opening the top flaps and lifting the unit out. Be careful of the staples. Make certain all parts and literature have been removed from the carton before the carton is discarded.
2. Disconnect and ground the spark plug wire against the engine. Check beneath the deck for any cardboard packaging. Remove if present.
3. Stretch out all control cables on the floor to rear of mower. Be careful not to bend or kink the cables at any time during assembly.
4. Remove page four from this manual and lay the contents of the hardware pack on the illustration for identification.
5. The chute deflector on your mower is held in an upright position by a pad for shipping purposes only. This shipping pad must be removed and discarded before the mower is put into operation. See figure 1.

ATTACHING THE LOWER HANDLE

1. Position lower handle so rope guide mounting hole and dimple, on handle cross bar, are facing downwards. See figure 3.
2. Slip one leg of lower handle onto the pin of one of the attaching brackets on the mower base. Apply inward pressure on the other leg of the handle and snap over the pin of the other attaching bracket. Secure with cotter pins supplied. See figure 2.

ATTACHING THE UPPER HANDLE

1. Position upper handle assembly so the engine control lever is on top side of the handle and attach to lower handle with (2) 5/16-18 x 1-1/2" hex head bolts, 5/16" split washers and 5/16-18 nuts. See Fig. 3.

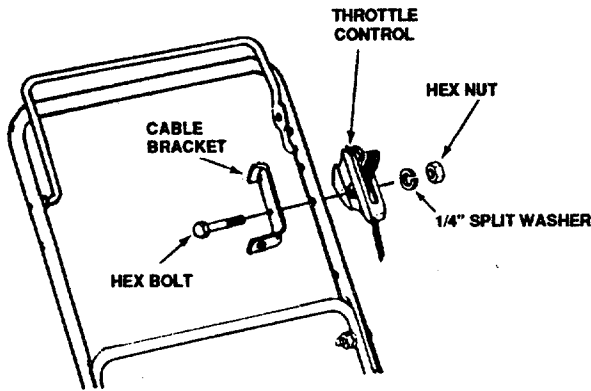

FIGURE 4.

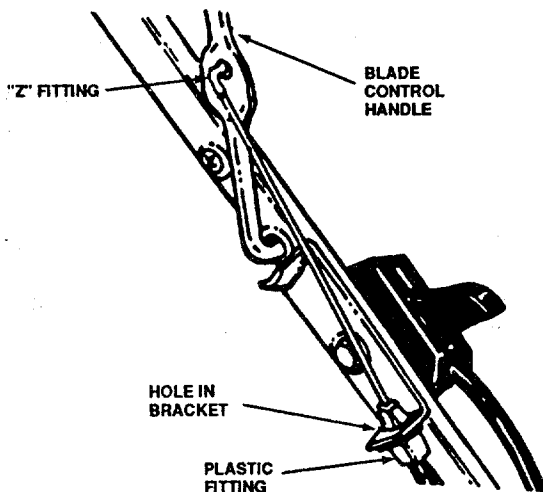

FIGURE 5.

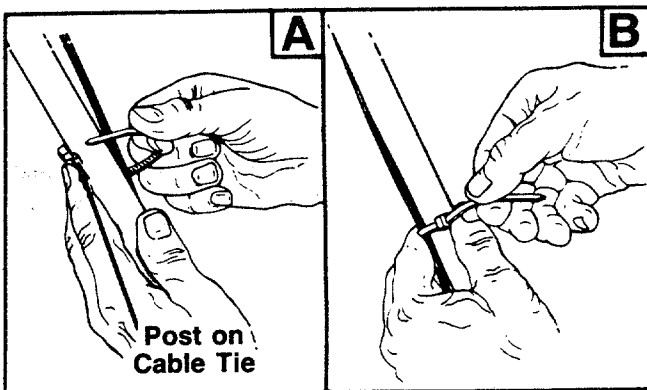

FIGURE 6.

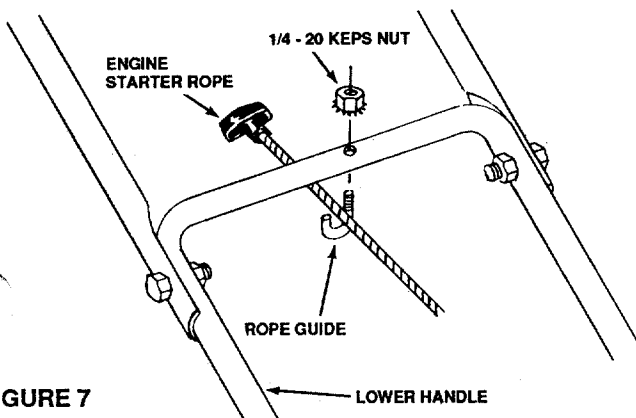

FIGURE 7

ATTACHING THE THROTTLE CONTROL

The throttle control cable is attached to the engine. Attach the throttle control to the left side of upper handle as follows (See Fig. 4).

1. Route the throttle control cable inside the legs and beneath the upper bar of the lower handle.
2. Place cable bracket against left side of upper handle, lining up the hole in the bracket with the bottom hole in upper handle. Place 1/4" hex bolt through cable bracket and handle, from the inside to the outside.
3. Place throttle control on the hex bolt (outside of upper handle), with the throttle lever facing upward. Secure with split washer hex nut.

ATTACHING THE BRAKE CABLE

1. The brake cable is attached to the engine, and has a "Z" fitting on the loose end. Route the brake cable below the lower handle. Place end of cable through the hole in the bracket as shown (See Fig. 5). Be careful not to bend or kink the cable at any time. Push the plastic fitting until it locks into the hole in the bracket.



WARNING: Brake cable must be assembled as shown for proper blade brake operation.

2. Hook the "Z" end of the brake cable into the hole in the blade control handle from the inside to the outside as shown (See Fig. 5).

SECURING THE CABLES

Secure all cables to the handle as follows.

1. Insert posts on cable ties into holes provided on the left side of the handle, one on the upper handle and two on the lower handle. The holes may be either on the inside or outside of the handles. See figure 6A.
2. Secure the cables with the cable ties. See figure 6B.
3. Trim excess ends of cable ties.

RECOIL STARTER ROPE ASSEMBLY

1. Attach starter rope to lower handle with supplied rope guide (J-bolt) and 1/4-20 hex keps lock nut as shown See Figure 7. NOTE: If additional rope is required to complete assembly, pull back engine control bail lever on upper handle and hold while slowly pulling additional rope out of engine as needed. Place rope guide around starter rope and through lower handle. Tighten securely with lock nut.

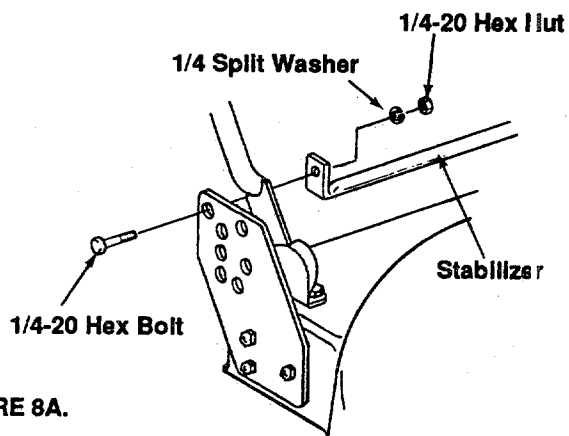

FIGURE 8A.

ATTACHING THE STABILIZER

1. Attach stabilizer to rear brackets with 1/4-20 x 5 hex bolts, 1/4" split washers and 1/4-20 hex nuts. See figure 8A. Assemble both sides loosely then tighten securely.

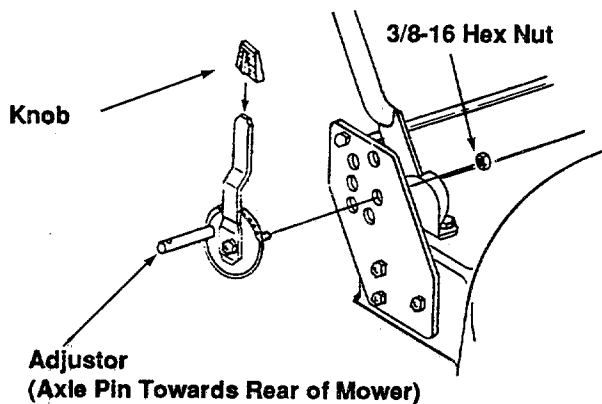

FIGURE 8B.

ATTACHING THE REAR HEIGHT ADJUSTORS

1. Attach the rear height adjustors to the angled holes in brackets as shown. See figure 8B. Secure with 3/8-16 hex nuts.

NOTE: The adjustors are different - assemble so axle pin on adjustor is toward rear of mower on both sides as shown.

2. Assemble plastic knobs to wheel height adjustor levers by pressing on or tapping lightly.

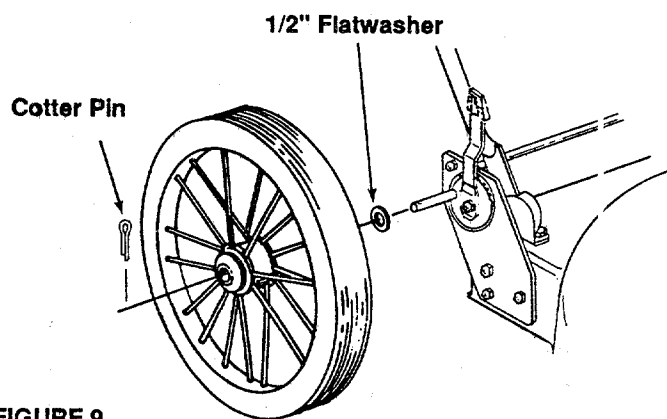

FIGURE 9.

ATTACHING THE REAR WHEELS

1. Attach rear wheels to adjusters with 1/2" flatwashers and cotter pins. See figure 9. Bend ends of cotter pins to secure.

CONTROLS

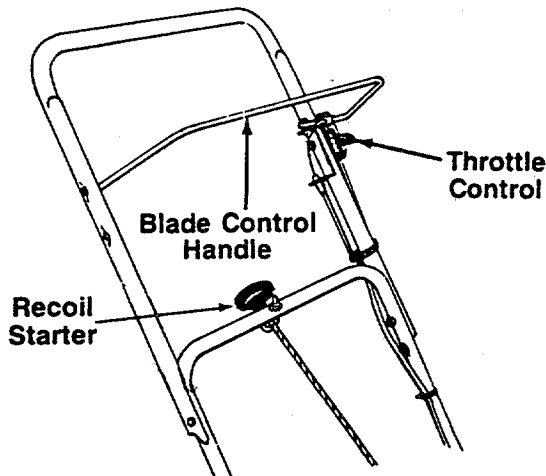

FIGURE 10.

BLADE CONTROL HANDLE

WARNING
THIS CONTROL MECHANISM IS A SAFETY DEVICE NEVER ATTEMPT TO BYPASS ITS OPERATIONS

The blade control handle is located on the upper handle of the mower. See figure 10. The blade control handle must be depressed in order to operate the unit. Release the blade control handle to stop the engine and blade.



WARNING: The blade will be rotating whenever the engine is running.

THROTTLE CONTROL

The throttle control is located on the side of the upper handle. It is used to regulate the engine speed.



WARNING: The throttle control cannot be used to stop the engine.

RECOIL STARTER

The recoil starter handle is attached to the handle. See figure 10. Stand behind the unit in the operating position to start the unit.

OPERATION



FIGURE 11.

Keep hands and feet away from the chute area on cutting deck. See figure 11.

The operation of any lawn mower can result in foreign objects being thrown into the eyes, which can result in severe eye damage. Always wear safety glasses or eye shields. We recommend wide vision safety mask for over spectacles or standard safety glasses, available at your nearest dealer.



NOTE: Adjust the cutting height of your mower before operating. See adjustment section of this manual.

GAS AND OIL FILL-UP

Service the engine with gasoline and oil as instructed in the separate engine manual packed with your mower. Read instructions carefully.



WARNING: Never fill fuel tank indoors, with engine running or until the engine has been allowed to cool for at least two minutes after running.

TO START ENGINE AND ENGAGE BLADE

1. Attach spark plug wire to spark plug. If unit is equipped with a rubber boot over the end of the spark plug wire, make certain the metal loop on the end of the spark plug wire (inside the rubber boot) is fastened securely over the metal tip on the spark plug. See figure 12.

Metal Loop on Spark Plug Wire

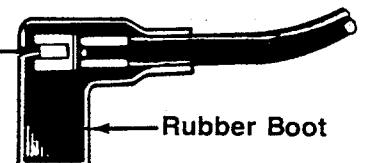

FIGURE 12.

2. Open fuel shut-off valve. See figure 13.

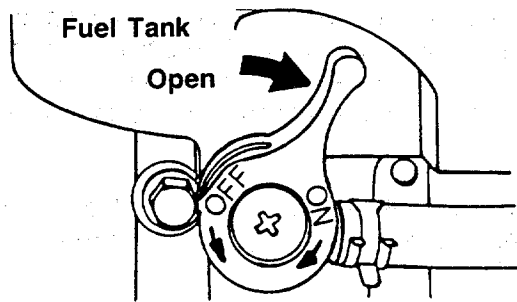

FIGURE 13.

3. Move throttle control lever all the way forward.
4. Standing behind the unit, depress the blade control handle and hold it against the upper handle as shown. See figure 14.
5. Grasp the recoil starter handle and pull back rapidly, extending rope fully. Return it slowly to the rope guide bolt.
6. After engine starts, move throttle control to desired engine speed.

NOTE: If any problems are encountered, refer to the *Trouble Shooting Guide* on page 13.

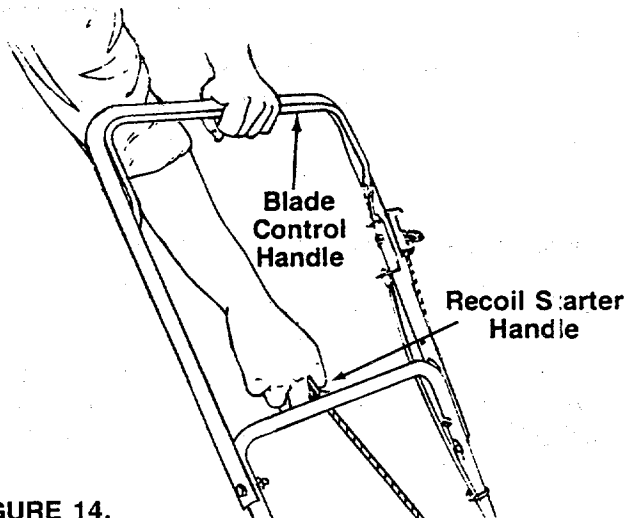

FIGURE 14.

TO STOP ENGINE AND BLADE

1. Release the blade control handle to stop the engine and blade.



WARNING: The blade continues to rotate for a few seconds after the engine is shut off.

2. Disconnect the spark plug wire and ground it against the engine to prevent accidental starting while equipment is unattended.

USING YOUR ROTARY MOWER

Be sure that lawn is clear of stones, sticks, wire, or other objects which could damage lawn mower or engine. Such objects could be accidentally thrown by the mower

in any direction and cause serious personal injury to the operator and others.

For the best results, do not cut wet grass because it tends to stick to the underside of the mower, preventing proper discharge of grass clippings, and could cause you to slip and fall. New grass, thick grass or wet grass may require a narrower cut. Blade speed should be adjusted to the condition of the lawn.

The best mowing pattern is one that allows the clippings to discharge towards the uncut part of the lawn. This permits recutting of the clippings to further pulverize them. When cutting high weeds, discharge towards cut portion, then recut at right angles to first direction.

For best results, cut off one-third or less of the total length of the grass. Lawn should be cut in the fall as long as there is growth.

This mower is designed to be operated at full throttle to give you the best cut and do the most effective job of bagging the cut grass.



WARNING: If you strike a foreign object, stop the engine. Remove wire from spark plug, thoroughly inspect the mower for any damage, and repair the damage before restarting and operating the mower. Extensive vibration of the mower during operation is an indication of damage. The unit should be promptly inspected and repaired.

ADJUSTMENTS



WARNING: Do not at any time make any adjustment to lawn mower without first stopping engine and disconnecting spark plug wire.

CUTTING HEIGHT ADJUSTMENT

An adjusting plate and thumb lever at each wheel position provides cutting height adjustment. Each adjusting plate has nine height positions. Height of cut will be changed when the thumb lever is moved from one hole to another. Simply depress the lever towards wheel and move wheel and lever assembly to desired position. All wheels must be placed in the same relative position. See figure 15.

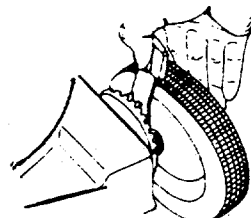

FIGURE 15.

THROTTLE CONTROL ADJUSTMENT

If the throttle control needs adjustment or if it has been replaced, adjust as follows.

1. Remove the screw shown in figure 17. Remove the cable clamp from the cable.
2. Push the throttle control lever on the handle all the way forward to CHOKE position. Make certain the throttle control lever remains in this position.
3. Push the control lever on the engine as far toward the rear of the engine as it will go. Secure the cable in this position with the cable clamp and screw.

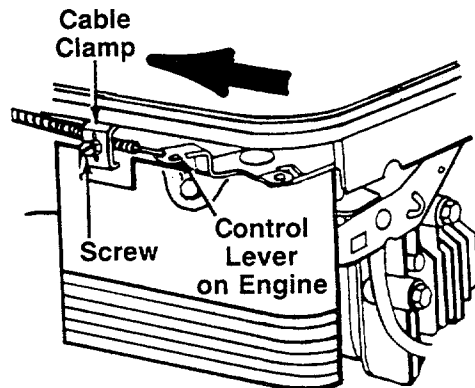

FIGURE 17.

CARBURETOR ADJUSTMENTS



WARNING: If any adjustments are made to the engine while the engine is running (e.g. carburetor), keep clear of all moving parts. Be careful of heated surfaces and muffler.

Minor carburetor adjustments may be required to compensate for differences in fuel, temperature, altitude and load. To adjust carburetor, refer to the separate engine manual packed with your mower.

NOTE: A dirty air cleaner will cause an engine to run rough. Be certain air cleaner is clean and attached to the carburetor before adjusting carburetor. Refer to the separate engine manual.

LUBRICATION



WARNING: Always stop engine and disconnect spark plug wire before cleaning, lubricating or doing any kind of work on lawn mower.

Blade Control—Lubricate the pivot points on the blade control handle and the brake cable at least once a season with light oil. See figure 18. The blade control must operate freely in both directions.

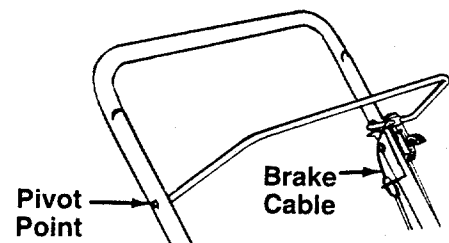

FIGURE 18.

Chute Deflector—The torsion spring and pivot point should be lubricated periodically with light oil to prevent any rust or binding. Deflector must work freely.

Wheels—Mower may be provided with ball bearing wheels. Lubricate at least once a season with light oil. Also, if the wheels are removed for any reason, lubricate the surface of the axle bolt and the inner surface of the wheel with light oil. A 4 oz. plastic bottle of light oil lubricant is available. Order part number 737-0170. Engine oil may also be used.

Engine—Follow engine manual for lubrication instructions.

Throttle—Periodically lubricate throttle control lever and throttle wire assembly with a few drops of light oil for ease of operation.

MAINTENANCE



WARNING: Be sure to disconnect and ground the spark plug wire before performing any repairs or maintenance.

NOTE: When tipping the unit, empty the fuel tank and keep engine spark plug side up.

TROUBLE SHOOTING

Refer to page 13 of this manual for trouble shooting information.

CUTTING BLADE

When removing the cutting blade for sharpening or replacement, protect hands by using heavy gloves or a rag to grasp the cutting blade. Remove the bolt and bell washer which hold the blade and adapter to the engine crankshaft. Remove the blade and adapter from the crankshaft.

If the blade or blade adapter needs replacing, remove the two small bolts, lock washers and nuts which hold the blade to the adapter.



WARNING: Periodically inspect the blade adapter for cracks, especially if you strike a foreign object. Replace when necessary.

When sharpening the blade, follow the original angle of grind as a guide. It is **extremely important** that each cutting edge receives an equal amount of grinding to prevent an unbalanced blade. An unbalanced blade will cause excessive vibration when rotating at high speeds, may cause damage to the mower and could break, causing personal injury.

It is recommended that the blade always be removed from the adapter for the best test of balance.

The blade can be tested by balancing it on a round shaft screwdriver. Remove metal from the heavy side until it balances evenly.

Before reassembling the blade and the blade adapter to the unit, lubricate the engine crankshaft and the inner surface of the blade adapter with light oil. Lubricating the bolt holes, bolts and inner surface of the nuts with light oil is also recommended. A 4 oz. plastic bottle of light oil lubricant is available. Order part number 737-0170. Engine oil may also be used.

When replacing the blade, be sure to install the blade with the side of the blade marked "Bottom" (or with part number) facing the ground when the mower is in the operating position.

Blade Mounting Torque

Center Bolt and Blade Adapter Bolts:
375 in. lb. min., 450 in. lb. max.

To insure safe operation of your unit, **all** nuts and bolts must be checked periodically for correct tightness.

DECK

The underside of the mower deck should be cleaned after each use to prevent a buildup of grass clippings, leaves, dirt or other matter. If this debris is allowed to accumulate, it will invite rust and corrosion, and may cause an uneven discharge of grass clippings at the next cutting.

The deck may be cleaned by tilting the mower and scraping clean with a suitable tool (make certain the spark plug wire is disconnected).

ENGINE

Refer to the separate engine manual for engine maintenance instructions.

Maintain **engine oil** as instructed in the separate engine manual packed with your unit. Read and follow instructions carefully.

Service **air cleaner** every 25 hours under normal conditions. Clean every few hours under extremely dusty conditions. Poor engine performance and flooding usually indicates that the air cleaner should be serviced. To service the air cleaner, refer to the separate engine manual packed with your unit.

The **spark plug** should be cleaned and the gap reset once a season. Spark plug replacement is recommended at the start of each mowing season; check engine manual for correct plug type and gap specifications.

Clean the engine regularly with a cloth or brush. Keep the cooling system (blower housing area) clean to permit proper air circulation which is essential to engine performance and life. Be certain to remove all grass, dirt and combustible debris from muffler area.

OFF-SEASON STORAGE

The following steps should be taken to prepare lawn mower for storage.

1. Clean and lubricate mower thoroughly as described in the lubrication instructions.
2. Refer to engine manual for correct engine storage instructions.
3. Coat mower's cutting blade with chassis grease to prevent rusting.
4. Store mower in a dry, clean area.

NOTE: When storing any type of power equipment in an unventilated or metal storage shed, care should be taken to rust-proof the equipment. Using a light oil or silicone, coat the equipment, especially cables and all moving parts.

TROUBLE SHOOTING GUIDE

Trouble	Possible Cause(s)	Corrective Action
Engine fails to start	<ol style="list-style-type: none"> 1. Blade control handle disengaged. 2. Spark plug wire disconnected. 3. Throttle control lever not in CHOKE or START position. 4. Fuel shut-off valve closed (if so equipped). 5. Fuel tank empty, or stale fuel. 6. Blocked fuel line. 7. Faulty spark plug. 8. Engine flooded. 	<ol style="list-style-type: none"> 1. Engage blade control handle. 2. Connect wire to spark plug. 3. Move throttle lever to CHOKE or START position. 4. Open fuel shut-off valve. 5. Fill tank with clean, fresh gasoline. 6. Clean fuel line. 7. Clean, adjust gap or replace. 8. Remove spark plug, dry the plug, and crank engine with plug removed and throttle in off position. Replace spark plug, connect wire and resume starting procedures.
Engine runs erratic	<ol style="list-style-type: none"> 1. Unit running in CHOKE or START position. 2. Spark plug wire loose. 3. Blocked fuel line or stale fuel. 4. Vent in gas cap plugged. 5. Water or dirt in fuel system. 6. Dirty air cleaner. 7. Carburetor out of adjustment. 	<ol style="list-style-type: none"> 1. Move throttle lever to FAST position. 2. Connect and tighten spark plug wire. 3. Clean fuel line; fill tank with clean, fresh gasoline. 4. Clear vent. 5. Drain fuel tank. Refill with fresh fuel. 6. Clean air cleaner.† 7. Adjust carburetor.†
Engine overheats	<ol style="list-style-type: none"> 1. Engine oil level low. 2. Air flow restricted. 3. Carburetor not adjusted properly. 	<ol style="list-style-type: none"> 1. Fill crankcase with proper oil. 2. Remove blower housing and clean.† 3. Adjust carburetor.†
Occasional skip (hesitates) at high speed	<ol style="list-style-type: none"> 1. Carburetor idle speed too slow. 2. Spark plug gap too close. 3. Carburetor idle mixture adjustment improperly set. 	<ol style="list-style-type: none"> 1. Adjust carburetor.† 2. Adjust gap to .030". 3. Adjust carburetor.†
Idles poorly	<ol style="list-style-type: none"> 1. Spark plug fouled, faulty or gap too wide. 2. Carburetor improperly adjusted. 3. Dirty air cleaner. 	<ol style="list-style-type: none"> 1. Reset gap to .030" or replace spark plug. 2. Adjust carburetor.† 3. Clean air cleaner.†
Excessive vibration	<ol style="list-style-type: none"> 1. Cutting blade loose or unbalanced. 2. Bent cutting blade. 	<ol style="list-style-type: none"> 1. Tighten blade and adapter. Balance blade. 2. Replace blade.
Mower will not discharge grass	<ol style="list-style-type: none"> 1. Engine speed too low. 2. Wet grass. 3. Excessively high grass. 	<ol style="list-style-type: none"> 1. Set throttle between 3/4 and full throttle. 2. Do not mow when grass is wet; wait until later to cut. 3. Mow once at a high cutting height, then mow again at desired height or make a narrower cutting swath (1/2 width).
Uneven cut	<ol style="list-style-type: none"> 1. Wheels not positioned correctly. 2. Dull blade. 	<ol style="list-style-type: none"> 1. Place all four wheels in same height position. 2. Sharpen or replace blade.

†Refer to separate engine manual packed with your unit.

Note: For repairs beyond the minor adjustments listed above, contact your local authorized service dealer.

Model A508R

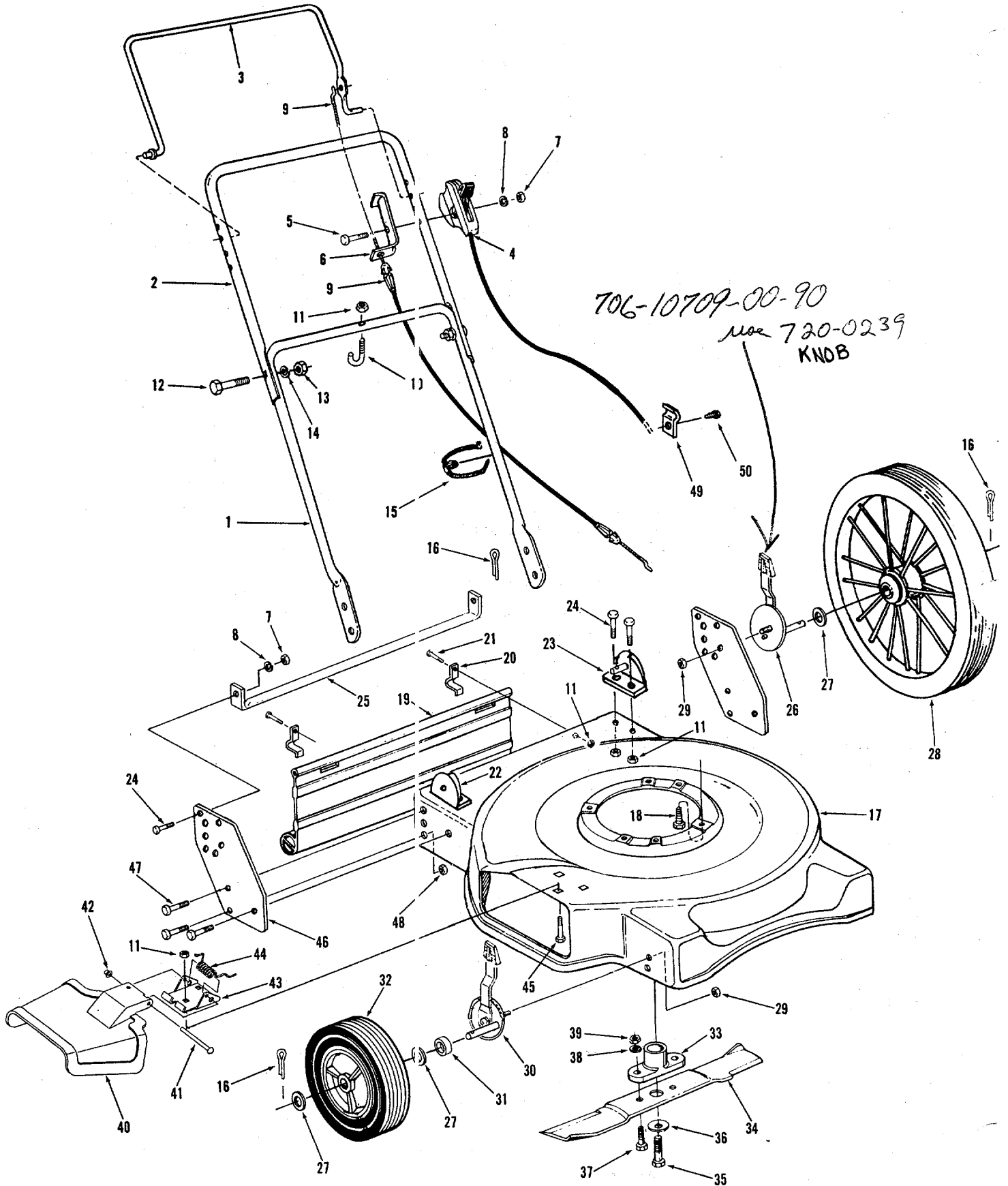

Model A508R

PARTS LIST FOR MODEL A508R ROTARY MOWER

REF. NO.	PART NO.	DESCRIPTION	REF. NO.	PART NO.	DESCRIPTION
1	749-0896	Lower Handle	27	706-10002	Fl-Wash. 1/2" I.D.*
2	749-0756	Upper Handle	28	734-1661	16" Steel Spoke Wheel
3	747-0748	Engine Control Lever	29	712-0431	Hex L-Nut 3/8-16 Thd
4	746-0761	Throttle Control	30	706-10127-02	Adjustor Ass'y - Right Front
5	710-0501	Hex Bolt 1/4-20 x 2.00" Lg.*	-	706-10128-02	Adjustor Ass'y - Left Front
6	17174	Cable Mounting Bracket	31	750-0796	Wheel Spacer
7	712-0287	Hex Nut 1/4-20 Thd*	32	734-1655	8" Wheel Ass'y
8	736-0329	L-Wash. 1/4" I.D.*	33	748-0485	Blade Adaptor Kit (Incl. 35,36,37, 38 and 39)
9	746-0553	Control Cable - 36"			
10	747-0779	Rope Guide (J-Bolt)	34	742-0522	22" Blade
11	712-0324	Hex L-Nut 1/4-20 Thd	35	710-0757	Blade Bolt (Special)
12	710-0442	Hex Bolt 5/16-18 x 1.50 Lg.*	36	736-0439	Bell-Wash. .460 I.D.
13	712-0267	Hex Nut 5/16-18 Thd*	37	710-1055	Hex Bolt 3/8-24 x 1.00 Lg.
14	736-0119	L-Wash. 5/16 I.D.*	38	736-0169	L-Wash. 3/8" I.D.*
15	726-0240	Cable Tie	39	712-0241	Hex Nut 3/8-24 Thd.
16	714-0474	Cotter Pin 1/8 x 3/4" Lg.*	40	706-15492-01-90	Chute Deflector
17	706-14267-01-10	22"Deck Ass'y	41	706-10115-03-05	Hinge Pin
18	706-10605-16	Engine Mtg. Bolt (Special)	42	706-10116	Retainer
19	731-1179	Rear Flap	43	706-10113-00-90	Adaptor Plate
20	706-10698-00-05	Hinge Bracket	44	706-15615-01	Spring
21	710-0258	Hex Bolt 1/4-20 x .62" Lg.*	45	710-0167	Carriage Bolt 1/4-20 x .50 Lg.*
22	706-10961-00-09	Handle Bracket - RH	46	706-13797-01-10	Bracket (Right & Left)
23	706-10960-00-09	Handle Bracket - LH	47	710-0216	Hex Bolt 3/8-16 x 3/4" Lg.*
24	710-0258	Hex Bolt 1/4-20 x .62" Lg.*	48	712-0430	Hex L-Nut 3/8-16 Thd.
25	706-13798	Stabilizer Bar	49	706-13913	Casing Clamp
26	706-15499	Adjustor Ass'y - Left Rear	50	706-14697-10	Scr. - Casing Clamp
-	706-15498	Adjustor Ass'y - Right Rear			

*For faster service obtain standard nuts, bolts and washers locally. If these items cannot be obtained locally, order by part number and size as shown on parts list.

PARTS INFORMATION

POWER EQUIPMENT PARTS AND SERVICE

Parts and service are available through the authorized service firms listed below. All orders should specify the model number of your unit, part numbers, description of parts and the quantity of each part required.

NOTE: If any parts are found to be missing or defective upon assembly of this unit, write to advise the factory so that immediate replacement can be made.

ARKANSAS	NORTH LITTLE ROCK
Sutton's Lawn Mower Shop.....	5301 Roundtop Drive Box 368, Rt. 4 72: 17
CALIFORNIA	PORTERVILLE
Billious	75 North D Street 93: 57
COLORADO	DENVER
Spitzer Industrial Products Co. ...	6601 N. Washington St. 80: 29
FLORIDA	JACKSONVILLE
Radco Distributors	4909 Victor St. Box 5459 32: 07
	HIALEAH
Small Eng. Dist.	7995 W. 26th Court 33: 16
ILLINOIS	LYONS
Keen Edge Co.	8615 Ogden Ave. 60: 34
INDIANA	ELKHART
Parts & Sales Inc.	2101 Industrial Pkwy. Box 277 46: 16
IOWA	DUBUQUE
Power Lawn & Garden Equip.	2551 J.F. Kennedy 52: 01
MARYLAND	BELTSVILLE
Center Supply Co.	6802 Industrial Dr. #208 20: 05
MASSACHUSETTS	SPRINGFIELD
Morton B. Collins Co.	300 Birnie Ave. 01: 107
MICHIGAN	MOUNT CLEMENS
Power Equipment Dist.	340 Hubbard 48: 43
MINNESOTA	PLYMOUTH
Hance Distributing Inc.	12795 16th Ave. North 55: 41
MISSOURI	EARTH CITY
Oscar Wilson Engine & Parts	4159 Shoreline Dr. 63: 45
	KANSAS CITY
Automotive Equip. Service	3117 Holmes St. 64: 109
NEW YORK	CARTHAGE
Gamble Dist., Inc.	West End Ave. Box 389 13: 19

BRIGGS AND STRATTON, TECUMSEH AND PEERLESS PARTS AND SERVICE

Briggs & Stratton, Tecumseh and Peerless parts and service should be handled by your nearest authorized engine service firm. Check the yellow pages of your telephone directory under the listing **Engines—Gasoline**, Briggs & Stratton or Tecumseh Lauson.

NORTH CAROLINA	BROWNS SUMMIT
Dixie Sales Company	5920 Summit Ave. 27: 214
OHIO	CARROLL
Stebe's Mid-State Mower Supply	Box 366, 71 High St. 43: 112
	CLEVELAND
Bleckrie, Inc.	7900 Lorain Ave. 44: 102
	WADSWORTH
National Central	687 Seville Rd. 44: 281
	YOUNGSTOWN
Burton Supply Co.	1301 Logan Ave. Box 929 44: 501
PENNSYLVANIA	HARRISBURG
EECO Inc.	4021 N. 6th St. 17: 110
	PITTSBURGH
Bluemont Co.	11101 Frankstown Rd. 15: 235
	PUNXSUTAWNEY
Frank Roberts & Sons	R.D. 2 15: 767
	SCRANTON
Scranton Auto Ignition Co.	1133-35 Wyoming Ave. 18: 509
TENNESSEE	KNOXVILLE
Ace Distributors	2103 Magnolia 37: 917
	NASHVILLE
Chilton Air Cooled Engine	319 4th Ave. S. 37: 210
TEXAS	DALLAS
Marr Brothers, Inc.	423 E. Jefferson 75: 203
UTAH	SALT LAKE CITY
Powered Products	1661 N. Beck St. 84: 116
VIRGINIA	ASHLAND
RBI Corp.	101 Cedar Ridge Dr. 23: 005
WASHINGTON	SEATTLE
Equip. Northwest	1410 14th Ave. 98: 122
WISCONSIN	MILWAUKEE
Wisconsin Magneto Inc.	4727 N. Teutonia St. 53: 209
PUERTO RICO	RAMEY
Island Distribution Center	102 N. St. 00: 604

WARRANTY PARTS AND SERVICE POLICY

(0689)

The purpose of warranty is to protect the customer from defects in workmanship and materials, defects which are NOT detected at the time of manufacture. It does not provide for the unlimited and unrestricted replacement of parts. Use and maintenance are the responsibility of the customer. The manufacturer cannot assume responsibility for conditions over which it has no control. Simply put, if it's the manufacturer's fault, it's the manufacturer's responsibility; if it's the customer's fault, it's the customer's responsibility.

CLAIMS AGAINST THE MANUFACTURER'S WARRANTY INCLUDES:

1. Replacement of Missing Parts on new equipment.
2. Replacement of Defective Parts within the warranty period.
3. Repair of Defects within the warranty period.

All claims MUST be substantiated with the following information:

1. Model Number, Serial Number and/or Date Code of unit involved.
2. Date unit was purchased.
3. Date of Failure.
4. Nature of Failure.

MTD PRODUCTS INC • P.O. BOX 360900 • CLEVELAND, OHIO 44136

Free Manuals Download Website

<http://myh66.com>

<http://usermanuals.us>

<http://www.somanuals.com>

<http://www.4manuals.cc>

<http://www.manual-lib.com>

<http://www.404manual.com>

<http://www.luxmanual.com>

<http://aubethermostatmanual.com>

Golf course search by state

<http://golfingnear.com>

Email search by domain

<http://emailbydomain.com>

Auto manuals search

<http://auto.somanuals.com>

TV manuals search

<http://tv.somanuals.com>